

## SECTION 1. Terms and Definitions

- 1.00** The following terms are basic and will be referred to in subsequent sections.
- 1.01 Gears** are machine elements that transmit motion by means of successively engaging teeth. (Figure 1.1)
- 1.02 A Gear** is any machine part with gear teeth. Of two gears that run together, the one with the larger number of teeth is called the gear. (Figure 1.1)
- 1.03 A Pinion** is a gear with a small number of teeth. Of two gears that run together, the one with the smaller number of teeth is called the pinion. (Figure 1.1)
- 1.04 A Rack** is a gear with teeth spaced along a straight line, and suitable for straight-line motion. (Figure 1.1)

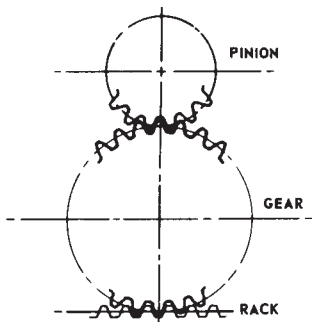

**FIGURE 1.1 — GEARS**

- 1.05 A Worm** is a gear with one or more teeth in the form of screw threads. (Figure 1.2)
- 1.06 A Wormgear** is the mate to a worm. A wormgear that is completely conjugate to its worm has line contact and is said to be single enveloping. It is usually cut by a tool that is geometrically similar to the worm. An involute spur gear or helical gear used with a cylindrical worm has only point contact. (Figure 1.2)

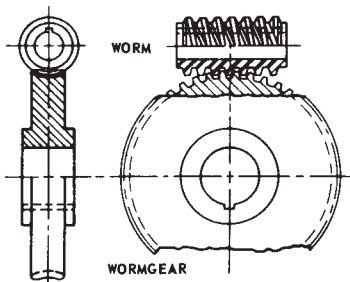

**FIGURE 1.2 — WORMGEARING**

- 1.07 A Helical Gear** is cylindrical in form and has helical teeth. (Figure 1.3)
- 1.08 Parallel Helical Gears** operate on parallel axes and, where both are external, the helices are of opposite hand. (Figure 1.3)

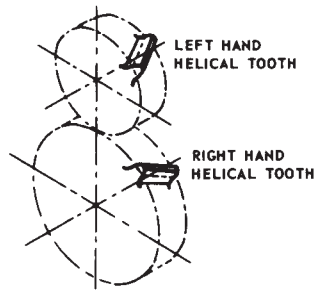

**FIGURE 1.3 — PARALLEL HELICAL GEARS**

- 1.09 Crossed Helical Gears** operate on crossed axes and may have teeth of the same or opposite hand. The term Crossed Helical Gears has superseded the old term "Spiral Gears." (Figure 1.4)

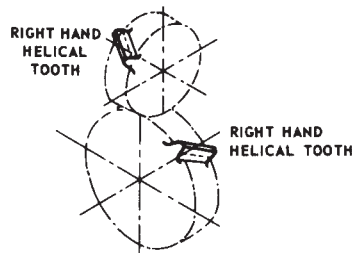

**FIGURE 1.4 — CROSSED HELICAL GEARS**

- 1.10 Bevel Gears** are conical in form and operate on intersecting axes which are usually at right angles. (Figure 1.5a)
- 1.11 Miter Gears** are mating bevel gears with equal numbers of teeth and with axes at right angles. (Figure 1.5b)

- 1.12 Straight Bevel Gears** have straight tooth elements, which if extended, would pass through the point of intersection of their axes. (Figure 1.5a)
- 1.13 Angular Bevel Gears** are bevel gears in which the axes are not at right angles. (Figure 1.5c)

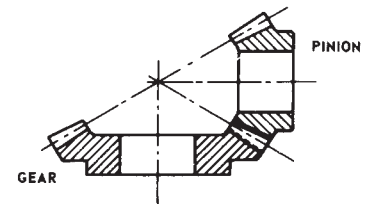

**FIGURE 1.5a — BEVEL GEARS**

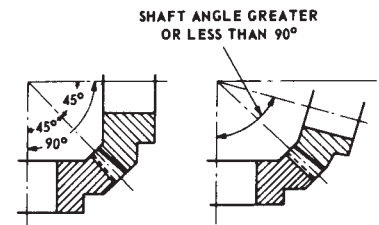

**FIGURE 1.5b — MITER GEARS**

**FIGURE 1.5c — ANGULAR BEVEL GEARS**

- 1.14 An Internal Gear** is one with the teeth formed on the inner surface of a cylinder or cone. An internal gear can be meshed only with an external pinion. (Figure 1.6)
- 1.15 An External Gear** is one with the teeth formed on the outer surface of a cylinder or cone. (Figure 1.6)

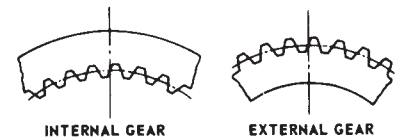

**FIGURE 1.6 — INTERNAL & EXTERNAL GEARS**

# TECHNICAL SECTION

## SECTION 1. Terms and Definitions

- 1.16 The Axial Plane** of a pair of gears is the plane that contains the two axes. In a single gear, an axial plane may be any plane containing the axis and a given point. (Figure 1.7)
- 1.17 The Pitch Plane** of a pair of gears is the plane perpendicular to the axial plane and tangent to the pitch surfaces. A pitch plane in an individual gear may be any plane tangent to its pitch surface. The pitch plane of a rack or crown gear is the pitch surface. (Figure 1.7)
- 1.18 A Transverse Plane** is perpendicular to the axial plane and to the pitch plane. In gears with parallel axes, the transverse plane and plane of rotation coincide. (Figure 1.7)
- 1.19 A Plane of Rotation** is any plane perpendicular to a gear axis. (Figure 1.7)

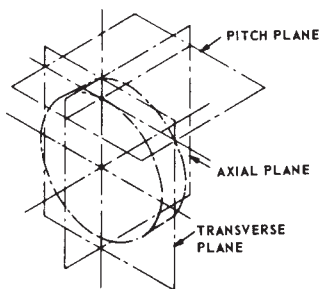

FIGURE 1.7 — PITCH, AXIAL & TRANSVERSE PLANES

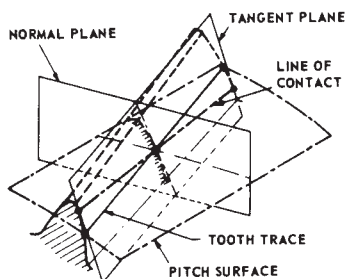

FIGURE 1.8 — NORMAL & TANGENT PLANES

- 1.20 A Normal Plane** is in general normal to a tooth surface at a pitch point, and perpendicular to the pitch plane. (Figure 1.8)
- 1.21 A Tangent Plane** is tangent to the tooth surfaces at a point or line of contact. (Figure 1.8)

- 1.22 Circular Pitch** is the distance along the pitch circle or pitch line between corresponding profiles of adjacent teeth. (Figure 1.9)

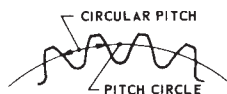

FIGURE 1.9 — CIRCULAR PITCH

- 1.23 Normal Circular Pitch** is the circular pitch in the normal plane, and also the length of the arc along the normal helix between helical teeth or threads. (Figure 1.10)
- 1.24 Axial Pitch** is linear pitch in an axial plane and in a pitch surface. In helical gears and worms, axial pitch has the same value at all diameters. In gearing of other types, axial pitch may be confined to the pitch surface and may be a circular measurement. (Figure 1.10)  
The term axial pitch is preferred to the term linear pitch. The axial pitch of a helical worm and the circular pitch of its wormgear are the same.
- 1.25 Transverse Circular Pitch** is the circular pitch in the transverse plane. (Figure 1.10)

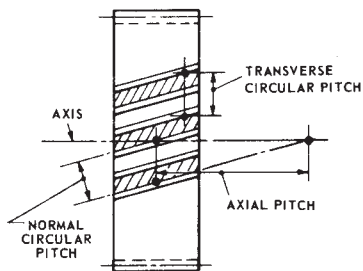

FIGURE 1.10 — NORMAL, TRANSVERSE & AXIAL PITCH

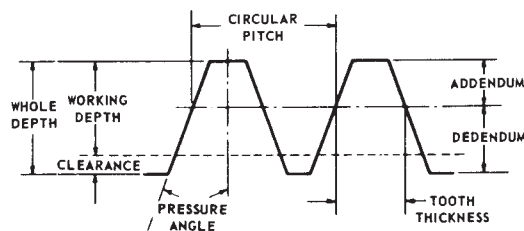

FIGURE 1.11 — BASIC RACK (NORMAL PLANE)

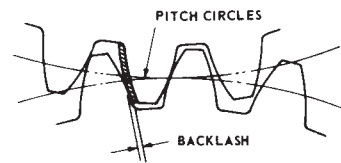

FIGURE 1.12 — BACKLASH

- 1.26 Addendum** is the height by which a tooth projects beyond the pitch circle or pitch line; also, the radial distance between the pitch circle and the addendum circle. (Figure 1.11)
- 1.27 Dedendum** is the depth of a tooth space below the pitch circle or pitch line; also, the radial distance between the pitch circle and the root circle. (Figure 1.11)
- 1.28 Clearance** is the amount by which the dedendum in a given gear exceeds the addendum of its mating gear. (Figure 1.11)
- 1.29 Working Depth** is the depth of engagement of two gears; that is, the sum of their addendums. (Figure 1.11)
- 1.30 Whole Depth** is the total depth of a tooth space, equal to addendum plus dedendum, also equal to working depth plus clearance. (Figure 1.11)
- 1.31 Pitch Diameter** is the diameter of the pitch circle.
- 1.32 Outside Diameter** is the diameter of the addendum (outside) circle.
- 1.33 Backlash** is the amount by which the width of a tooth space exceeds the thickness of the engaging tooth on the operating pitch circles. (Figure 1.12)

Sold & Serviced By:

**ELECTROMATE**

Toll Free Phone (877) SERV098

Toll Free Fax (877) SERV099

www.electromate.com

sales@electromate.com

### SPUR AND HELICAL GEARS

**2.00** This section covers the recommended tooth proportions and design data for fine pitch spur and helical gears.

**2.01 Basic Rack** — The basic rack shown in Figure 2.1 is used to illustrate the tooth proportions covered by this standard. When small numbers of teeth, or special center distance situations are encountered, it is intended that long and short addendum proportions be used. This standard permits freedom of choice in making minor changes in the tooth proportions to meet special design conditions as long as the resulting gears are fully conjugate to the basic rack. Such changes may be indicated when a special contact ratio or top land is desired.

**2.02 Spur Gears** — The basic rack shown in Figure 2.1 and the tooth proportions shown in Table 2.1 provide the basic design data for spur gear teeth.

**2.03 Helical Gears** — The helical teeth covered by this standard are conjugated in the normal plane to the basic rack shown in Figure 2.1 and Table 2.1.

**2.04 Standard Center Distance** — Standard center distance is given by the equation shown in Table 2.1.

**2.05 Center Distance Systems** — There are two center distance systems in use. These are the Standard Center-Distance System and the Enlarged Center-Distance System. The choice of which is used will depend on the number of teeth in the meshing gears and on other design requirements. When an enlarged pinion is to be meshed with a gear at the center distance that is standard for the numbers of teeth, the gear diameter and tooth thickness must be decreased by the amount of the pinion enlargement. When two enlarged pinions or an enlarged pinion and a standard diameter gear are meshed together, the center distance must be greater than standard.

**2.06 Standard Center-Distance System** — (Long and short addendums.) In this system the center of distance is made standard for the number of teeth, and the pressure angle remains constant. The outside diameter and root diameter of the gear is decreased the same amount that the pinion diameter is increased.

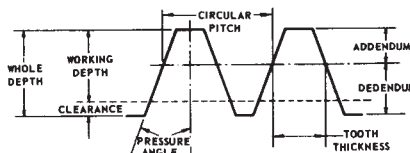

FIGURE 2.1 — BASIC RACK — (NORMAL PLANE)

**2.07 Spur Pinion Enlargement** — Enlargement of Spur Pinions of 20 Degree Pressure Angle and Diametral Pitches from 20 through 120. Spur pinions having fewer than the minimum numbers of teeth shown in Table 2.2 should be enlarged to avoid objectional undercut.\* Pinions of 20 degree pressure angle should be enlarged in accordance with the recommendations given in Table 2.3. The mating gear or the center distance should be adjusted as discussed in paragraph 2.05. Pinions of finer than 120 diametral pitch require special consideration since the proportionally larger clearance requires hobs which tend to produce greater undercut. In general, pinions cut by the shaping process will not have as much undercut as those cut by hobbing.

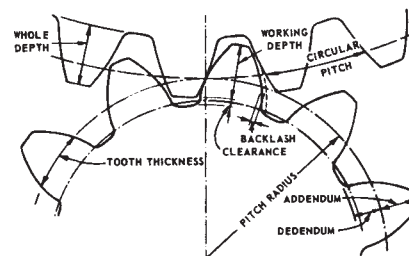

FIGURE 2.2 — SPUR, HELICAL, GEAR NOMENCLATURE

TABLE 2.1  
TOOTH PROPORTIONS AND FORMULAS FOR  
DIAMETERS AND STANDARD CENTER DISTANCE

(All values in millimeters)

TOOTH PROPORTIONS		
Item	Spur	Helical
Addendum (a)	M	$M_n$
Dedendum (b)	$M + c = 1.16M$	$M_n + c = 1.16m_n$
Working Depth ( $h_w$ )	2.000M	2.000 $M_n$
Whole Depth ( $h_t$ )	2.16M	2.16 $M_n$
Clearance (c) (Standard)	.1M to .3M (.166M typically)	.1 $M_n$ to .3 $M_n$ (.166 $M_n$ typically)
Tooth Thickness (t) at Pitch Diameter	$t = \frac{\pi M}{2}$	$t_n = \frac{\pi M_n}{2}$
FORMULAS		
Metric Module (M)	D/N	
Circular Pitch (p)	$p = \pi M$ or $\pi \frac{D}{N}$	$p_n = \pi M_n$ or $\pi \frac{D}{N}$
Pitch Diameter (D)	NM	$\frac{NM}{\cos \psi}$
Outside Diameter ( $D_o$ )	(N + 2)M	$\left(\frac{N}{\cos \psi} + 2\right) M_n$
Center Distance (C)	$\frac{(N + n)M}{2}$	$\frac{(N + n)}{2 \cos \psi} M_n$

Where M = Metric Module  
 $M_n$  = Normal Metric Module  
 $t_n$  = Normal Tooth Thickness at Pitch Diameter  
 p = Circular Pitch  
 $p_n$  = Normal Circular Pitch  
 $\psi$  = Helix Angle  
 N = Number of Gear Teeth  
 n = Number of Pinion Teeth  
 D = Pitch Diameter

(All values in inches)

TOOTH PROPORTIONS		
Item	Spur	Helical
Addendum (a)	$\frac{1.000}{P}$	$\frac{1.000}{P_n}$
Dedendum (b)	$\frac{1.200}{P} + 0.002$ (min.)	$\frac{1.200}{P_n} + 0.002$ (min.)
Working Depth ( $h_w$ )	$\frac{2.000}{P}$	$\frac{1.200}{P_n}$
Whole Depth ( $h_t$ )	$\frac{2.200}{P} + 0.002$ (min.)	$\frac{2.200}{P_n} + 0.002$ (min.)
Clearance (c) (Standard)	$\frac{0.200}{P} + 0.002$ (min.)	$\frac{0.200}{P_n} + 0.002$ (min.)
(Shaved or Ground Teeth)	$\frac{0.350}{P} + 0.002$ (min.)	$\frac{0.350}{P_n} + 0.002$ (min.)
Tooth Thickness (t) at Pitch Diameter	$t = \frac{1.5708}{P}$	$t_n = \frac{1.5708}{P_n}$
FORMULAS		
Circular Pitch (p)	$p = \frac{\pi D}{N}$ or $\frac{\pi d}{n}$	$P_n = \frac{\pi}{P_n}$
Pitch Diameter Pinion (d)	$\frac{n}{P}$	$\frac{n}{P_n \cos \psi}$
Pitch Diameter Gear (D)	$\frac{N}{P}$	$\frac{N}{P_n \cos \psi}$
Outside Diameter Pinion ( $d_o$ )	$\frac{n + 2}{P}$	$\frac{1}{P_n} \left(\frac{n}{\cos \psi} + 2\right)$
Outside Diameter Gear ( $D_o$ )	$\frac{N + 2}{P}$	$\frac{1}{P_n} \left(\frac{N}{\cos \psi} + 2\right)$
Center Distance (C)	$\frac{N + n}{2P}$	$\frac{N + n}{2P_n \cos \psi}$

Where P = Transverse Diametral Pitch  
 $P_n$  = Normal Diametral Pitch  
 $t_n$  = Normal Tooth Thickness at Pitch Diameter  
 $P_n$  = Normal Circular Pitch  
 $\psi$  = Helix Angle  
 n = Number of Pinion Teeth  
 N = Number of Gear Teeth

# TECHNICAL SECTION

## SECTION 2. Basic Gear Formulas

### SPUR AND HELICAL GEARS

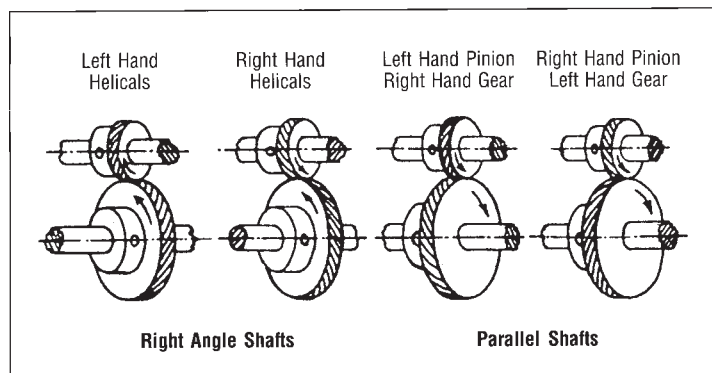

FIGURE 2.3 — HELICAL GEARS OF THE SAME HAND MESH AT RIGHT ANGLES  
— HELICAL GEARS OF THE OPPOSITE HAND MESH ON PARALLEL SHAFTS

Any gear will mesh and run with any other gear of the same pitch. Recommend meshing stainless steel with aluminum gears for smoother running, longer life and silent operation. For best operation helical gears should run with thrust washers — see PIC standard stock thrust washers on page 6-11 and reference below.

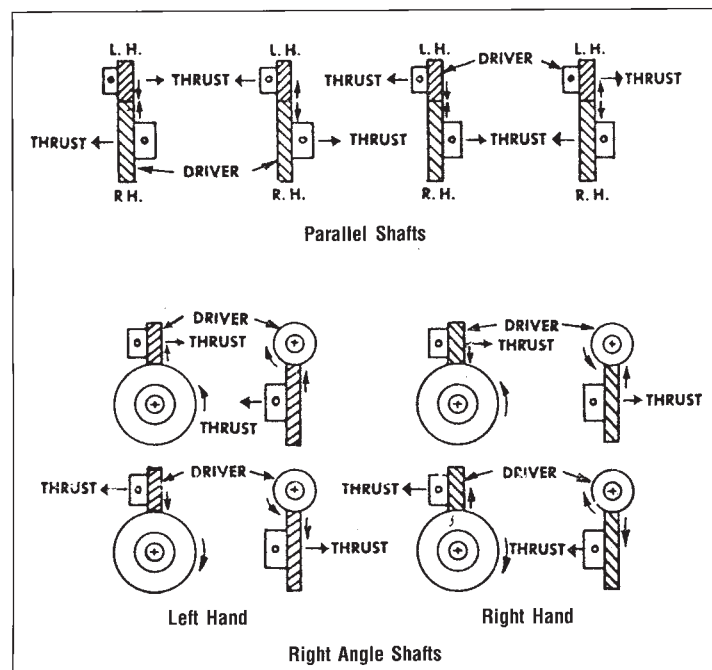

FIGURE 2.4 — THRUST LOADING DETAILS

TABLE 2.2  
MINIMUM NUMBER OF PINION TEETH VS. PRESSURE ANGLE AND HELIX ANGLE  
HAVING NO OBJECTIONABLE UNDERCUT

Helix Angle, Degrees	Minimum Number of Teeth to Avoid Undercut. Normal Pressure Angle, $\phi_n$ , degrees		
	14 1/2	20	25
0 (Spur Gears)	32	18	12
5	32	17	12
10	31	17	11
15	29	16	11
20	27	15	10
23	26	14	10
25	25	14	9
30	22	12	8
35	19	10	7
40	15	9	6
45	12	7	5

TABLE 2.3  
20-DEGREE PRESSURE ANGLE INVOLUTE FINE-PITCH SYSTEM FOR MODIFIED  
17 TEETH OR LESS SPUR PINIONS

(All tabular dimensions are given in inches for 1 diametral pitch. For other pitches divide tabular values by diametral pitch.)

Pinion Dimensions			Standard Center-Distance System (Long and Short Addendum) Gear Dimensions <sup>1</sup>				Enlarged Center-Distance System Standard Mating Gear Diameter <sup>2</sup>	
Number of Teeth n	Outside Diameter	Cir. Tooth Thickness at Standard Pitch Diameter $\Delta t_p = \Delta d \tan \phi$	Decrease in Standard Outside Diameter	Cir. Tooth Thickness at Standard Pitch Diameter $\Delta t_g = \Delta D \tan \phi$	Recommended Minimum Number of Teeth (N)	Contact Ratio, n Mating With N <sup>3</sup>	Increase Over Standard Center Distance	Contact Ratio Two Equal Pinions <sup>3</sup>
10	12.8302	1.8730	0.8302	1.2686	33	1.419	0.4151	1.135
11	13.7132	1.8304	0.7132	1.3112	30	1.450	0.3566	1.186
12	14.5963	1.7878	0.5963	1.3538	27	1.473	0.2982	1.238
13	15.4793	1.7452	0.4793	1.3964	25	1.493	0.2397	1.290
14	16.3623	1.7027	0.3623	1.4389	23	1.508	0.1812	1.344
15	17.2453	1.6601	0.2453	1.4815	21	1.516	0.1227	1.398
16	18.1284	1.6175	0.1284	1.5241	19	1.519	0.0642	1.436
17	19.0114	1.5749	0.0114	1.5667	18	1.522	0.0057	1.511

The outside diameters of small pinions are enlarged to avoid undercut. Enlargements are based on addendum proportions of the basic rack, Figure 2.1, of  $\frac{1.000}{P}$ . When different proportions are used, the outside diameter must be adjusted accordingly.

- To maintain standard center distances when using enlarged pinions, the mating gear diameters must be decreased by the amount of the pinion enlargement.
- If mating gears are made with standard tooth proportions, the center distances must be increased as shown.
- Nominal Values: will vary due to effects of tolerances.

Sold & Serviced By:

**ELECTROMATE**

Toll Free Phone (877) SERV098

Toll Free Fax (877) SERV099

www.electromate.com

sales@electromate.com

### STRAIGHT BEVEL GEARS

- 2.08** This section covers recommended tooth proportions and dimensions of blanks for generated straight bevel gears of tooth ratios in general industrial use.
- 2.09 Bevel Gears** in this system have unequal addendums and unequal tooth thicknesses, except for pairs having equal numbers of teeth. This is different from the common practice for spur gearing. In bevel gear cutting, the tooth thickness is controlled by machine adjustments instead of by the tools, making it possible to obtain tooth thicknesses according to requirements for balance of strength in gear and pinion. Consideration has been given to both surface durability and beam strength in determining the tooth proportions.
- 2.10 An Advantage** in designing bevel gears according to this system is that tables are available giving tooth data and machine settings, thus minimizing calculations.\* If other tooth designs are used, the data must be determined specially.
- 2.11 Angular Bevel Gears** are bevel gears whose shafts are set at an angle other than 90 degrees.
- 2.12 Backlash** — Table 2.4 gives the recommended backlash when the gear and pinion are finished and assembled ready to run. Quality numbers referred to in the Table are defined by the AGMA Gear Classification Manual, AGMA 390.02.

TABLE 2.4 RECOMMENDED BACKLASH

Diametral Pitch	Backlash	
	AGMA Quality Number	
	4 thru 6	7 thru 13
20 to 50	0.000 - 0.002	0.000 - 0.002
50 to 80	0.000 - 0.001	0.000 - 0.001
80 and finer	0.000 - 0.0007	0.000 - 0.0007

\* These tables are available through Gleason Works, Rochester, New York.

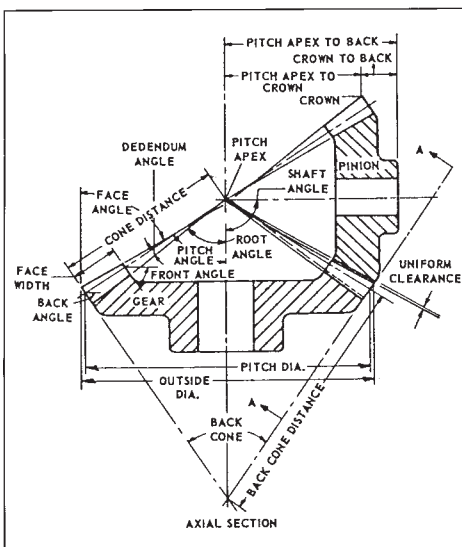

FIGURE 2.5 — BEVEL GEAR NOMENCLATURE

### WORMGEARING

- 2.13 Wormgearing** is generally divided into two categories, fine-pitch worm gearing and coarse-pitch worm gearing. Fine-pitch worm gearing is segregated from coarse-pitch worm gearing for the following reasons:
- 2.14 Fine-Pitch Wormgears** are used largely to transmit motion rather than power. Tooth strength, except at the coarser end of the fine-pitch range, is seldom an important factor. Durability and accuracy, as they affect the transmission of uniform angular motion, are of greater importance. Housing constructions and lubricating methods are generally radically different in fine-pitch wormgearing.
- 2.15 Profile Deviations** and tooth bearings cannot be determined to the same degree of accuracy as those of coarse-pitch worms and wormgears, because of their small size.
- 2.16 Wormgear** cutting equipment generally available for fine-pitch gears has definite restrictions which limit the diameter and lead range, degree of accuracy and kind of tooth bearing obtainable.

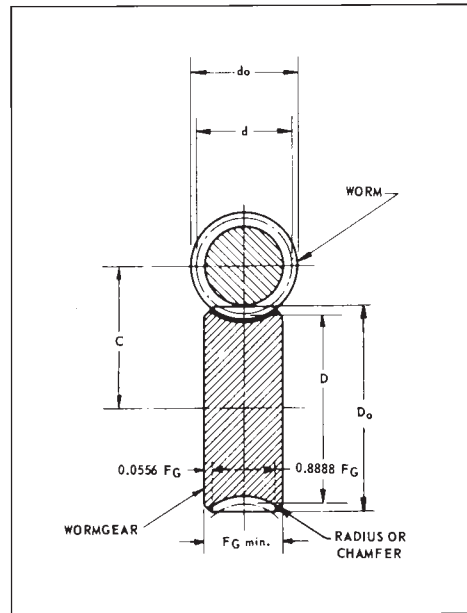

FIGURE 2.6 — WORM & WORMGEAR

- 2.17 Special Consideration** must be given to top lands in fine-pitch hardened worms and in gear cutting tools.
- 2.18 In Fine-Pitch Worms and Wormgears**, interchangeability and high production are important factors. Individual matching of the worm to the gear, as is frequently practiced with coarse-pitch precision worms, is impractical in the case of worms of fine pitch.
- 2.19 The Methods** of production and inspection of fine-pitch wormgears are generally different from those of coarse pitch.
- 2.20 Proportions** of worms and wormgears are given in Table 2.5. The pitch relations are expressed by the following formulas:

TABLE 2.5 PROPORTIONS OF FINE PITCH WORMS AND WORMGEARS

Worm Dimensions		
Term	Symbol	Formula (in.)
Lead	l	$n P_x$
Pitch Diameter	d	$1 \div (\pi \tan \lambda)$
Outside Diameter	$d_o$	$d + 2a$
Safe Minimum Length of Threaded Portion of Worm	$F_w$	$\sqrt{D_o^2 - D^2}$

\* This formula allows a sufficient length for fine-pitch worms.

Wormgear Dimensions		
Term	Symbol	Formula
Pitch Diameter	D	$N p + \pi$
Outside Diameter	$D_o$	$2C - d + 2a$
Minimum Face Width of Wormgear	$F_{G \min}$	$1.125 \sqrt{(d_o + 2c)^2 - (d - 4a)^2}$

Data Relating to Worm and Wormgear		
Term	Symbol	Formula
Addendum	a	$0.3183 P_n$
Whole Depth	$h_i$	$0.7003 P_n + 0.002$
Working Depth	$h_k$	$0.6366 P_n$
Clearance	c	$h_i - h_k$
Tooth Thickness	t	$0.5 P_n$
Approximate Normal Pressure Angle	$\phi_n$	20 deg
Center Distance	C	$0.5 (d + D)$

- Where  $p$  = Circular Pitch of Wormgear  
 $P_x$  = Axial Pitch of Worm  
 $P_n$  = Normal Circular Pitch of Worm and Wormgear  
 $= P_x \cos \lambda = p \cos \psi$   
 $\lambda$  = Lead Angle of Worm  
 $\psi$  = Helix Angle of Wormgear  
 $n$  = Number of Threads in Worm  
 $N$  = Number of Teeth in Wormgear

Sold & Serviced By:  
 **ELECTROMATE**  
 Toll Free Phone (877) SERV098  
 Toll Free Fax (877) SERV099  
[www.electromate.com](http://www.electromate.com)  
[sales@electromate.com](mailto:sales@electromate.com)

# TECHNICAL SECTION

## SECTION 3. Backlash Calculations

**3.00 Backlash** is the amount by which the width of a tooth space exceeds the thickness of the engaging tooth on the operating pitch circles. The following section contains a description of backlash sources and a method of calculating backlash in a gear train.

### 3.01 Sources of Backlash

For precision trains the backlash sources are many because of the significance of every contributor even if small. There are five major descriptive groupings:

### 3.02 Design Backlash Allowance

1. Gear size allowance — any specific reduction of gear size (tooth thickness or testing radius) below nominal value.
2. Center distance — any specific increase in center distance above nominal value.

### 3.03 Major Tolerance Backlash Sources

1. Gear size to tolerance (tooth thickness or testing radius).
2. Center distance tolerance.

### 3.04 Gear Center Shift Due to Secondary Sources

1. Fixed-bearing eccentricities:
  - a. Outer-race eccentricity of ball bearings
  - b. Sleeve bearing's inside-diameter and outside-diameter runout.
2. Radial clearances due to tolerances and allowances:
  - a. Ball-bearing radial play.
  - b. Fit between shaft and bearing bore.
  - c. Fit between bearing outside diameter and housing bore.
3. Component error sources:
  - a. Clearance between component-mounting pilot diameter and housing-mounting bore.
  - b. Component-mounting pilot eccentricity to shaft.
  - c. Component-mounting surface flatness and perpendicularity.
  - d. Component shaft radial play.

### 3.05 Backlash Sources Variable in Magnitude with Gear Rotation

1. Total composite error:
  - a. Runout.
  - b. Tooth-to-tooth errors.
  - c. Lateral runout.
2. Clearance between gear bore and shaft
3. Shaft runout at point of gear mounting:
  - a. Plain shafting.
  - b. Stepped stud or shaft.
4. Ball-bearing rotating-race eccentricity
5. Miscellaneous runouts:
  - a. Component shaft.
  - b. Composite gear assembly.

### 3.06 Miscellaneous Sources:

1. Thermal dimensional changes.
2. Deflections: teeth, gear body, shaft, and housing.
3. Special environmental conditions — vibration, etc.

### 3.07 Example of Backlash Calculation

To illustrate procedures, an example of calculating gear train backlash is given. Referring to Figure 3.1, backlash from the servomotor to the antenna azimuth shaft will be calculated. This illustrates a typical problem encountered in the design of small radar antenna drive gear trains in which backlash is important to a responsive and stable servo system. Additional design conditions not given in the figure and Table 3.1 are listed below (all dimensions in inches.)

**TABLE 3.1**  
**DESIGN CONDITIONS FOR FIG. 3.1 GEAR TRAIN**

Parameter	Mesh 1	Mesh 2	Mesh 3	Mesh 4
Gear size (testing radius):				
Allowance	0	0	.0005	.0005
Tolerance	+ .0000 - .0007	+ .0000 - .0012	+ .0000 - .0015	+ .0000 - .0015
Total composite error (max.)	.0005	.001	.001	.001
Center Distance:				
Allowance	0	0	0	0
Tolerance	+ .001 - .000	+ .002 - .000	+ .002 - .000	+ .002 - .000

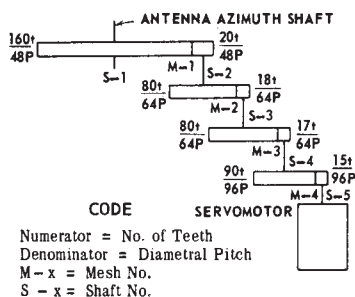

**FIGURE 3.1 — GEARING SCHEMATIC AND DESIGN DETAILS FOR A SMALL RADAR ANTENNA DRIVE GEAR TRAIN**

### 3.08 Entire TCE must be within Testing Radius Tolerance Bearings:

All, except motor shafts, ABEC-5 ball bearings, 1/2 inch diameter. Radial clearance .0002 to .0006.

### 3.09 Housing Bore for Bearing Outside Diameter:

Allowance zero  
tolerance + .0003  
- .0000

### 3.10 Shaft Diameter:

Allowance .0001 from nominal diameter  
tolerance + .0000  
- .0002

### 3.11 Shaft Runout at Mounting of Gear .0002 max. TIR.

### 3.12 Gear Bore Diameter:

Nominal dimension + .0003  
- .0000

### 3.13 Servomotor Details:

Pinion cut on shaft — testing radius reduced .0005 under nominal, with - .0011 tolerance.  
Shaft radial play .001 max.  
Shaft runout .0008 max. TIR at mounting of gear.  
Mounting diameter runout relative to shaft .001 TIR max.  
Component-mounting design:  
Mounting pilot diameter tolerance: + .0000  
- .0005  
Mating-housing bore diameter tolerance: + .0005  
- .0000  
Allowance: .0003.

### 3.14 Pinion Design:

Mesh 1 — pinned to shaft.  
All other meshes — pinion is cut integral with shaft.

### 3.15 All Gears 20° pressure angle.

**3.16 The Backlash** contributors for each mesh are listed in Table 3.2. These are radial values (i.e., changes in center distance) and are converted to backlash by the factor  $2 \tan \phi$ , in this case .728. Thus, the angular values are

$${}_a B_{m-1} = \frac{2 \tan \phi \Delta C}{R_i} \times \frac{180 \times 60}{\pi}$$

#### Mesh 1:

$${}_a B_{m-1} = \frac{.728(.0052)3438}{1.6667} = 7.8 \text{ min of arc}$$

#### Mesh 2:

$${}_a B_{m-2} = \frac{.728(.0068)3438}{6.250} = 27.1 \text{ min of arc}$$

#### Mesh 3:

$${}_a B_{m-3} = \frac{.728(.0084)3438}{6.250} = 33.5 \text{ min of arc}$$

#### Mesh 4:

$${}_a B_{m-4} = \frac{.728(.00865)3438}{.4688} = 46 \text{ min of arc}$$

Summing the mesh totals, with proper velocity ratio factors relative to reference shaft S-1, the gear train maximum backlash is

$$\left[ \text{Backlash from S-1 to S-5 measured at S-1} \right] =$$

$$B_{\text{train}} = B_{m-1} + \frac{B_{m-2}}{V_1} + \frac{B_{m-3}}{V_2} + \frac{B_{m-4}}{V_3}$$

$$B_{\text{train}} = 7.8 + \frac{27.1}{8} + \frac{33.5}{35.6} + \frac{46}{167}$$

$$= 12.4 \text{ min of arc}$$

Note that 63 per cent of the train backlash is in the first mesh because of the high velocity ratios of subsequent meshes. Calculation of the third mesh contribution is of questionable significance, and the fourth mesh is unnecessary.

The backlash value calculated is a maximum which will never be exceeded if parts are made according to design specification; it can be approached only if all backlash design tolerances are at their maximum values.

Sold & Serviced By:

**ELECTROMATE**

Toll Free Phone (877) SERV098

Toll Free Fax (877) SERV099

www.electromate.com

sales@electromate.com

# TECHNICAL SECTION

## SECTION 3. Backlash Calculations

**TABLE 3.2  
BACKLASH EXAMPLE CALCULATION**

Backlash Source		Maximum Backlash (Radial Value)							
		Mesh 1		Mesh 2		Mesh 3		Mesh 4	
		Gear	Pinion	Gear	Pinion	Gear	Pinion	Gear	Component Pinion
Design Data:		S-1	S-2	S-2	S-3	S-3	S-4	S-4	S-5
Shaft No. → Pitch Dia. →		3.333	.4167	1.250	.2812	1.250	.2656	.9375	.1562
Group I. Design Backlash Allowance									
* 1. Center distance allowance		0	—	0	—	0	—	0	—
2. Gear size allowance		0	0	0	0	.0005	.0005	.0005	.0005
Group II. Major Tolerances									
* 1. Center distance		.001	—	.002	—	.002	—	.002	—
2. Gear size		.0007	.0007	.0012	.0012	.0015	.0015	.0015	.0011
Group III. Secondary Sources									
1. Fixed-bearing eccentricities:									
a. Ball-bearing fixed race		.0001	.0001	.0001	.0001	.0001	.0001	.0001	
b. Sleeve-bearing runout									
2. Radial clearances:									
a. Ball-bearing radial play		.0003	.0003	.0003	.0003	.0003	.0003	.0003	
b. Clearance: Shaft and bearing bore									
(1) Shaft diameter tolerance		.0001	.0001	.0001	.0001	.0001	.0001	.0001	
(2) Bearing bore tolerance		.0001	.0001	.0001	.0001	.0001	.0001	.0001	
(3) Allowance		.00005	.00005	.00005	.00005	.00005	.00005	.00005	
c. Clearance: Bearing OD and housing bore									
(1) Bearing OD tolerance		.0001	.0001	.0001	.0001	.0001	.0001	.0001	
(2) Housing bore diameter tolerance		.00015	.00015	.00015	.00015	.00015	.00015	.00015	
(3) Allowance		0	0	0	0	0	0	0	
3. Component error sources:									
a. Clearance: component mounting									
(1) Component-mounting pilot dia. tolerance									.00025
(2) Housing-mounting bore dia. tolerance									.00025
(3) Allowance									.00015
b. Component's mounting pilot eccentricity									.0005
c. Component-mounting pilot flatness and perpendicularity									.0005
d. Component shaft radial play									
Group IV. Sources Variable with Rotation (one-half total value)									
1. Total composite error									
a. Runout		All TCE specified to be within testing radius tolerance							
b. Tooth-to-tooth composite									
2. Clearance: Gear mounting to shaft									
a. Gear bore diameter tolerance		.00015	.00015	.00015		.00015		.00015	
b. Shaft diameter tolerance		.0001	.0001	.0001		.0001		.0001	
c. Allowance		.00005	.00005	.00005		.00005		.00005	
3. Shaft runout at gear mounting		.0001	.0001	.0001		.0001		.0001	
4. Ball-bearing rotating-race eccentricity		.0001	.0001	.0001	.0001	.0001	.0001	.0001	
5. Miscellaneous runouts									
a. Component shaft									
b. Composite gear assembly									
6. Other sources									
Group V. Miscellaneous Sources									
1. Thermal									
2. Deflections									
3. Other sources									
Sub-Total		.0031	.0021	.0046	.0022	.0054	.0030	.0054	.00325
Mesh Total		.0052		.0068		.0084		.00865	

\* These are values for a pair and are arbitrarily put into gear columns.

Sold & Serviced By:

 **ELECTROMATE**

Toll Free Phone (877) SERV098

Toll Free Fax (877) SERV099

[www.electromate.com](http://www.electromate.com)

[sales@electromate.com](mailto:sales@electromate.com)

# TECHNICAL SECTION

## SECTION 4. Gear Strength Calculations

**4.00 In Fine-Pitch Gearing Applications**, gear trains are sometimes subject to high static loads. An example would be when a mechanism is driven into a mechanical stop. It is extremely important that the gears be capable of withstanding this maximum static torque. The following section contains a method by which static strength of gears can be calculated, in addition to a graphical representation of the strengths of different sizes of gears.

**4.01 The Lewis Formula** is used for determining the force which may safely be applied to spur gear teeth. This formula considers the gear as a cantilever beam with the full load applied to one tooth. It should be remembered that more than one tooth is actually in contact during engagement and therefore the load is partially shared with another pair of teeth. The amount of this load distribution is dependent upon the contact ratio of the particular gears in mesh. Typical values are from 1.2 to 1.8.

**4.02 The Curves** (Figure 4.1) are based on the Lewis Formula (using 303 Stainless Steel,  $S = 30,000$  psi)

$$L = \frac{SFY}{P} \text{ where}$$

$L$  = Maximum safe tangential load at pitch diameter, lbs.

$S_s$  = Allowable static unit stress for material, psi

$S$  = Allowable unit stress for material at given velocity

$$\left( S = S_s \times \frac{600}{600 + V} \right), \text{ psi}$$

$V$  = Velocity, FPM at pitch diameter

$F$  = Face width of gear, in.

$Y$  = Outline factor (machinery handbook, 16th ed. p717)

$P$  = Diametral pitch

\* The curves represent static gear tooth strength, therefore

$$V = 0 \text{ and } S = S_s$$

### Method 1. Using Lewis Formula

Static torque capacity,  $T_s = \frac{L \times P.D.}{2}$  in. oz.

$$P.D. = \frac{\text{No. Teeth}}{\text{Pitch}} = \frac{50}{48} = 1.0417 \text{ in.}$$

$$S = 40,000 \text{ psi (See Table 4.1)}$$

$$F = .187 \text{ in.}$$

$$Y = .408$$

$$P = 48$$

$$L = \frac{SFY}{P} = \frac{(40,000) (.187) (.408) (16)}{48}$$

$$L = 1017.28 \text{ ounces}$$

$$T_s = \frac{1017.28 \times 1.0417}{2} = 529.85 \text{ in. Oz.}$$

### Method 2. Using Torque Curves

Start at 50 Teeth on Gear

Go to 48 Pitch Curve

Read Torque 132 in. oz. for 1/16 Face Width

Multiply by 3 for 3/16 Face Width = 396 in. oz.

Since the curves are based on 303 Stainless Steel with a yield strength of 30,000 psi, torque must be multiplied by strength factor 1.33 to determine capacity of 2024-T4 Aluminum Gear (40,000 psi).

$$T_s = 396 \times 1.33 = 529 \text{ in. oz.}$$

EXAMPLE: Determine the Static Torque capacity ( $T_s$ ) of a 48 Pitch, 50 Tooth, 2024-T4 Aluminum Gear. Face width 3/16 inch.

**TABLE 4.1**  
YIELD STRENGTH FOR VARIOUS MATERIALS

Material	Yield Strength, PSI*	Strength Factor
416 Stainless Steel (Annealed)	40,000	1.33
416 Stainless Steel (RC22)	95,000	3.16
416 Stainless Steel (RC37)	134,000	4.46
303 Stainless Steel	30,000	1.00
17-4PH Stainless Steel (Cond. H900)	170,000	5.66
2024-T4 Aluminum Alloy	40,000	1.33
Bronze	20,000	.66
Phenolic	8,000	.27
Nylon, Delrin	6,000	.20

\* Data approximate, subject to variations among suppliers.

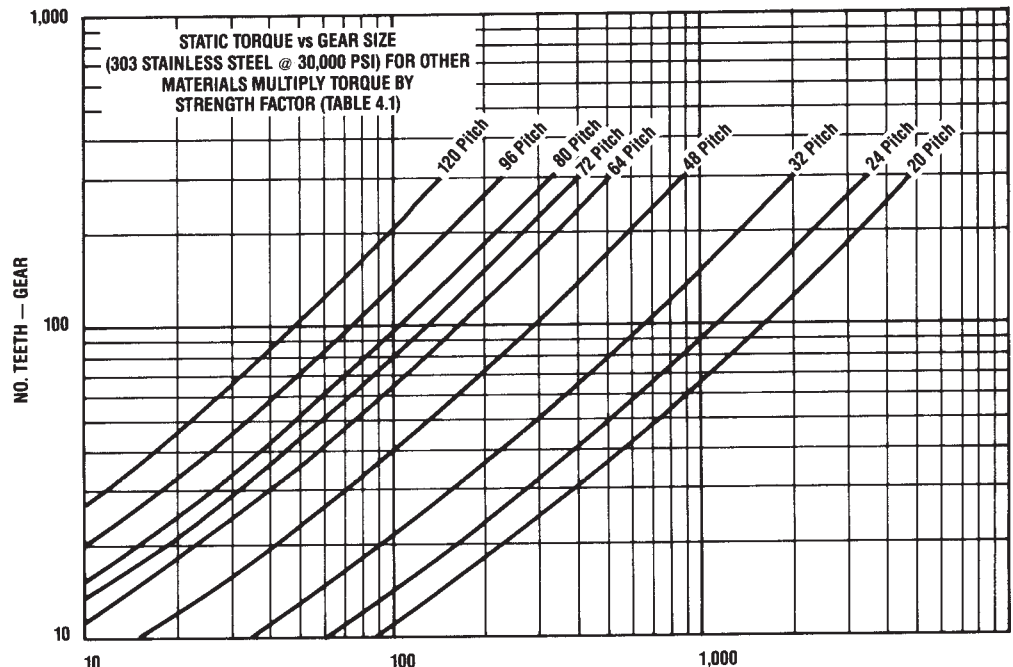

FIGURE 4.1 — STATIC TORQUE IN. OZ. (PER 1/16" FACE WIDTH GEAR)

Sold & Serviced By:

**ELECTROMATE**

Toll Free Phone (877) SERV098

Toll Free Fax (877) SERV099

www.electromate.com

sales@electromate.com



# TECHNICAL SECTION

## SECTION 5. Tolerances

### COMPOSITE ERROR CHECK

**5.00 PIC Gears** are inspected on variable center distance equipment where they are meshed with a master gear under light checking pressure (tabulated below). As the gears rotate, center distance changes are greatly amplified and recorded on PIC "TRUE BLUE" Gear Tapes as shown in Figure 5.1

**5.01 Refer to Gear Tolerance Tables 5.2 and 5.3** for detailed gear tolerances. Individual "True Blue" tapes are available with PIC spur and bevel gears for a nominal additional charge based on the quantity involved.

### GEAR TESTING RADIUS

**5.02 Gear Size** is controlled by specifying a maximum and a minimum gear testing radius. The inspection trace must lie between these limits. The maximum limit for PIC stock gears is set at the theoretical pitch radius. The minimum limit is determined by the class of gear being cut.

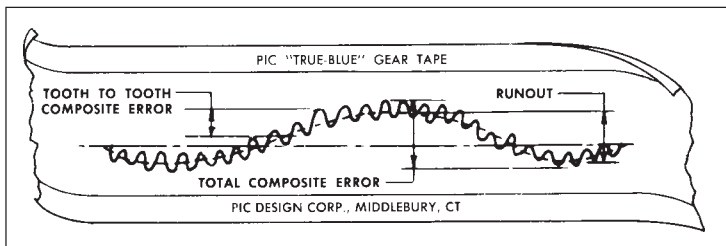

FIGURE 5.1 — "TRUE BLUE" GEAR TAPE

**TABLE 5.1**  
**AGMA 390.03 FINE-PITCH GEAR TOLERANCES TABLE**

AGMA Quality No.	No. of Teeth and Pitch Diameter	Diametral Pitch Range	Tooth-to-Tooth Composite Tolerance	Total Composite Tolerance
10*	Up to 20 Teeth Incl.	20 to 200	.0007	.0010
	Over 20 Teeth Up to 1.999"	20 to 200	.0005	.0010
	Over 20 Teeth 2" to 3.999"	20 to 200	.0005	.0012
	Over 20 Teeth 4" and over	20 to 200	.0005	.0014
11	Up to 20 Teeth Incl.	20 to 200	.0005	.0007
	Over 20 Teeth Up to 1.999"	20 to 200	.0004	.0007
	Over 20 Teeth 2" to 3.999"	20 to 200	.0004	.0009
	Over 20 Teeth 4" and over	20 to 200	.0004	.0010
12**	Up to 20 Teeth Incl.	20 to 200	.0004	.0005
	Over 20 Teeth Up to 1.999"	20 to 200	.0003	.0005
	Over 20 Teeth 2" to 3.999"	20 to 200	.0003	.0006
	Over 20 Teeth 4" and over	20 to 200	.0003	.0007
13	Up to 20 Teeth Incl.	20 to 200	.0003	.0004
	Over 20 Teeth Up to 1.999"	20 to 200	.0002	.0004
	Over 20 Teeth 2" to 3.999"	20 to 200	.0002	.0004
	Over 20 Teeth 4" and over	20 to 200	.0002	.0005
14***	Up to 20 Teeth Incl.	20 to 200	.00019	.00027
	Over 20 Teeth Up to 1.999"	20 to 200	.00014	.00027
	Over 20 Teeth 2" to 3.999"	20 to 200	.00014	.00032
	Over 20 Teeth 4" and over	20 to 200	.00014	.00037
15	Up to 20 Teeth Incl.	20 to 200	.00014	.00019
	Over 20 Teeth Up to 1.999"	20 to 200	.00010	.00019
	Over 20 Teeth 2" to 3.999"	20 to 200	.00010	.00023
	Over 20 Teeth 4" and over	20 to 200	.00010	.00027

**TABLE 5.2**  
**GEAR TOLERANCES**

AGMA Class Gear	P.D. Tol.	O.D. Tol.	Bore Tol.	C.D. Fixed Centers	C.D. Adjustable Centers
Q-10	-.001	-.002	+.0005	+.0005	+.002
Q-12	-.0007	-.0015	+.0003	+.0003	+.0015
Q-14	-.0005	-.001	+.0002	+.0002	+.0012

**TABLE 5.3**  
**AGMA 2015-2-A06 FINE-PITCH GEAR TOLERANCES TABLE**

PIC Quality Number	DIN Δ Quality Number	Pitch Diameter	Metric Module Range	Tooth-to-Tooth Composite Tolerance μm	Total Composite Tolerance μm
T7	C7 / T7	Up to 12mm	Up to 0.6 Module	7	20
		Over 12 to 50mm		9	25
		Over 50 to 100mm		10	28
		Over 100mm		11	32
T6	C6 / T6	Up to 12mm	Up to 0.6 Module	8	22
		Over 12 to 50mm		10	28
		Over 50 to 100mm		11	32
		Over 100mm		12	36
T5	C5 / T5	Up to 12mm	Up to 0.6 Module	5	14
		Over 12 to 50mm		5.5	16
		Over 50 to 100mm		6	18
		Over 100mm		7	20
T5	C5 / T5	Up to 12mm	Up to 0.6 Module	5	14
		Over 12 to 50mm		3.5	10
		Over 50 to 100mm		4	11
		Over 100mm		4.5	12
T5	C5 / T5	Up to 12mm	Up to 0.6 Module	5	14
		Over 12 to 50mm		3.5	11
		Over 50 to 100mm		4.5	12
		Over 100mm		5	14

Δ DIN, ISO, ANSI  
All Dimensions in millimeters

Extracted from AGMA Gear Classification Manual for Spur, Helical and Herringbone Gears (AGMA 390.03), with the permission of the publisher, The American Gear Manufacturers Association, 1330 Massachusetts Avenue, N.W., Washington, D.C. 20005.

\* AGMA 390.03/PIC Q10 = AGMA/ANSI 2015-2-A06 C7/ISO T7

\*\* AGMA 390.03/PIC Q12 = AGMA/ANSI 2015-2-A06 C6/ISO T6

\*\*\* AGMA 390.03/PIC Q14 = AGMA/ANSI 2015-2-A06 C5/ISO T5

Sold & Serviced By:

 **ELECTROMATE**

Toll Free Phone (877) SERV098

Toll Free Fax (877) SERV099

www.electromate.com

sales@electromate.com

# TECHNICAL SECTION

## SECTION 5. Military Specifications — Shaft and Bearing Fits

**TABLE 6.1  
MILITARY CROSS REFERENCES**

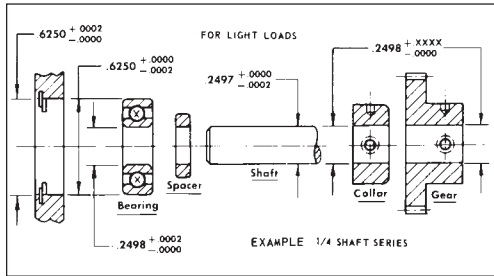

### STANDARD TOLERANCES

#### Inch

Unless otherwise specified, tolerances are as follows:

Two (2) place decimals ± .016

Three (3) place decimals ± .005

Fractional ± 1/32

Angles ± 1°

#### Metric

(All dimensions in millimeters)

Unless otherwise specified, tolerances are as follows:

One (1) place decimals ± 0.8

Two (2) place decimals ± 0.13

Angles ± 1°

Materials			Finishes		Used On
PIC Catalog Designation	UNS Designation	Mil. or Fed. Specification	PIC Catalog Designation	Mil. or Fed. Specification	PIC Products
#303 Stainless Steel (Bar)	S30300	ASTM-A-582	**	**	Gears <sup>(2)</sup> , Shafts, Couplings
#303 Stainless Steel (Sheet)	S30300	ASTM-A-666	**	**	Gears <sup>(2)</sup>
#303 Stainless Steel (Spring Temper)	S30200	ASTM-A-666	**	**	Springs, Washers
#416 Stainless Steel	S41600	ASTM-A-582	**	**	Racks, Gears, Shafts
#440 Stainless Steel	S44004	QQ-S-763 Class 10 Type A	**	**	Ball Bearings
#420 Stainless Steel	S42000	QQ-S-763	**	**	Retainer Rings
2024-T4/T351 Alum (Bar)	A92024	QQ-A-225/6	Anodized	MIL-A-8625	Gears <sup>(2)</sup> , Spacer Posts
2024-T3 Alum (Sheet)	A92024	QQ-A-250/4	Anodized	MIL-A-8625	Gears <sup>(2)</sup>
2024-T4/T351 Alum (Bar)	A92024	QQ-A-225/6	Black Anodized	MIL-A-8625	Dials, Drum
2024-T3 Alum (Sheet)	A92024	QQ-A-250/4	Black Anodized	MIL-A-8625	Dials, Disc
#108 Cast Aluminum	—	ASTM-B26	Anodized	MIL-A-8625	Hangers, Breadboards
Bronze (Tobin)	C46400	ASTM-B-21 Alloy 464	—	—	Worm Wheels
Oil-Less Bronze	—	MIL-B-438 Type II Grade 1	Lubricated with SAE 30 Oil	—	Bearings Thrust Washers
Brass (Laminated)	—	MIL-S-22499 Comp. 2 Class 1	—	—	Shims
Beryllium Copper	—	QQ-C-533	Anodized	MIL-A-8625	Retainer Rings
Neoprene (Molded)	—	MIL-R-6855 Class II	—	—	Flex. Couplings Pulley Belts
Grease	—	MIL-G-23827	—	—	Gears, Bearings -65°F to +250°F
Oil	—	MIL-G-6085	—	—	Gears, Bearings -65°F to +250°F
A2 Stainless Steel (Type #304)	S30400	DIN 267 (QQ-S-763)	**	**	Fasteners
A4 Stainless Steel (Type #316)	S31600	DIN 267 (QQ-S-763)	**	**	Fasteners

### NOTES:

**1. Brief description of the UNIFIED NUMBERING SYSTEM**

The unified numbering system (UNS) provides a means of correlating many nationally used numbering systems currently administered by societies, trade associations, and individual users and producers of metal and alloys, thereby avoiding confusion caused by use of more than one identification number for the same material — and by the opposite situation of having the same number assigned to two or more entirely different materials

**2. Refer to 12-4 for gear material specifications by product series.**

\*\*Clear passivate finish to military or federal specifications. Available upon request.

Sold & Serviced By:

**ELECTROMATE**

Toll Free Phone (877) SERV098

Toll Free Fax (877) SERV099

www.electromate.com

sales@electromate.com

# TECHNICAL SECTION

## SECTION 7. Equivalent

**TABLE 7.1**  
**TABLE OF EQUIVALENT DIAMETER MODULE AND**  
**CIRCULAR PITCHES**

Diametral Pitch	Circular Pitch (inches)	Circular Pitch (millimeters)	Module (millimeters)
20*	0.1571	3.990	1.2700
24*	0.1309	3.325	1.0583
25.4000	0.1237	3.142	1.0*
31.4159	0.1000*	2.540	0.8085
31.7500	0.0989	2.513	0.8*
32*	0.0982	2.494	0.7938
36.2857	0.0866	2.199	0.7*
42.3333	0.0742	1.885	0.6*
48*	0.0654	1.662	0.5292
50.8000	0.0618	1.571	0.5*
63.5000	0.0495	1.257	0.4*
64*	0.0491	1.247	0.3969
72*	0.0436	1.108	0.3528
80*	0.0393	0.997	0.3175
84.6667	0.0371	0.942	0.3*
96*	0.0327	0.831	0.2646
101.6000	0.0309	0.785	0.25*
120*	0.0262	0.665	0.2117
127.0000	0.0247	0.628	0.2*
200*	0.0157	0.399	0.1270

\*Standard pitches and modules offered by PIC Design.

**TABLE 7.2**  
**SPUR GEAR DATA**

Standard Stock Pitches	Addendum	Dedendum	Whole Depth	Circular Pitch
20	.0500	.0579	.1079	.1571
24	.0417	.0520	.0937	.1309
1/10	.0318	.0402	.0720	.1000
32	.0313	.0395	.0708	.0982
48	.0208	.0270	.0478	.0654
64	.0156	.0208	.0364	.0491
72	.0139	.0187	.0326	.0436
80	.0125	.0170	.0295	.0393
96	.0104	.0145	.0249	.0327
120	.0083	.0120	.0203	.0262
200	.0050	.0080	.0130	.0157

**TABLE 7.3**  
**SPUR GEAR DATA FOR STANDARD MODULES**  
(All dimensions in millimeters)

Standard Module M	Addendum M	Dedendum* 1.16M	Whole Depth 2.16M	Circular Pitch πM
0.2	0.200	0.234	0.434	0.628
0.25	0.250	0.292	0.541	0.785
0.3	0.300	0.350	0.650	0.943
0.4	0.400	0.467	0.866	1.256
0.5	0.500	0.584	1.085	1.571
0.6	0.600	0.701	1.300	1.885
0.7	0.700	0.818	1.519	2.199
0.8	0.800	0.935	1.735	2.513
1.0	1.000	1.166	2.167	3.142

\* Based on clearance equalling one-sixth module.

**NOTE:**

To determine theoretical center distance of gears, add the total number of teeth in both gears, then determine the pitch diameter and divide by two.

**EXAMPLE:**

Using a 99 and 18 tooth gears, using 24 D.P. gears =  $99 + 18 = 117$

P.D. =  $\text{teeth/pitch} = 117/24 = 4.875$ "

Theoretical Center Distance is  $4.875 / 2 = 2.4378$ .

To allow for any variations add 0.001"

Set up P.D. = theoretical plus 0.001" = 2.4388"

$$DP = \frac{25.4}{\text{Module}} \quad \text{Module} = \frac{25.4}{D.P.}$$

Sold & Serviced By:



Toll Free Phone (877) SERV098

Toll Free Fax (877) SERV099

www.electromate.com

sales@electromate.com