

SPEED REDUCER & GEAR HEADS

MECHANICAL SPECIFICATIONS DATA

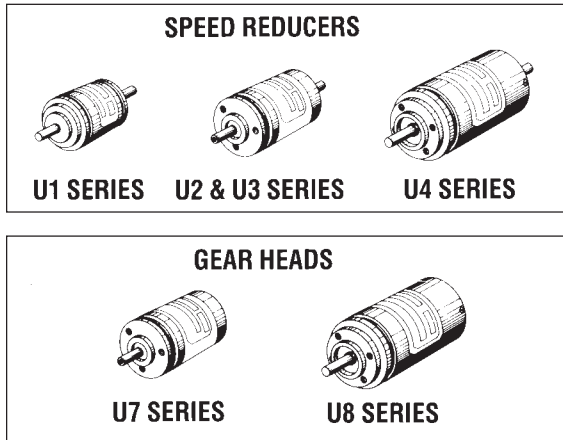

Specification	U1 Series	U2, U3 & U7 Series	U4 & U8 Series
Maximum Rated Output Torque	40 oz. in.	65 oz. in.	125 oz. in.
Frame Size and Dia. of Unit	Size 10, 15/16 Dia.	Size 11, 1-1/16 Dia.	Size 18, 1-3/4 Dia.
Shaft Size	1/8" Dia. & 3mm	1/8" Dia. & 3mm	1/4" Dia. & 6mm
Max. Operating Load Torque	25 oz. in.	30 oz. in.	65 oz. in.
Starting Torque (Max.)	.004 oz. in.	.005 oz. in.	.03 oz. in.
Backlash (Max.) Measured at Output Shaft with 5 oz. in. Rev. Load	30 Min. (Max.)	30 Min. (Max.)	30 Min. (Max.)
Lubricated Per MIL Specs.	Oil Per MIL-L-6085a Grease Per MIL-G-23827a		
Ball Bearings	ABEC-5 or Better		
Gear Tolerances	Q12 or Better		
Shaft Radial Play	With 4 oz. Gage Load .002 In. Per In. Length Max.		
Shaft End Play	With 1 Lb. Gage Load .004 In. Max.		
Weight (Approx.)	2 oz.	3 oz.	8 oz.
Moment of Inertia at Input Shaft (Approx.)	.007 Gm-Cm ²	.015 Gm-Cm ²	.135 Gm-Cm ²
Use with PIC Breadboard Hanger	S1-10 Modified	S1-8	S1-3

PRECISION SPEED REDUCER

Inch and Metric Input and Output Shafts ■ 15/16" Dia. ■ Size 10

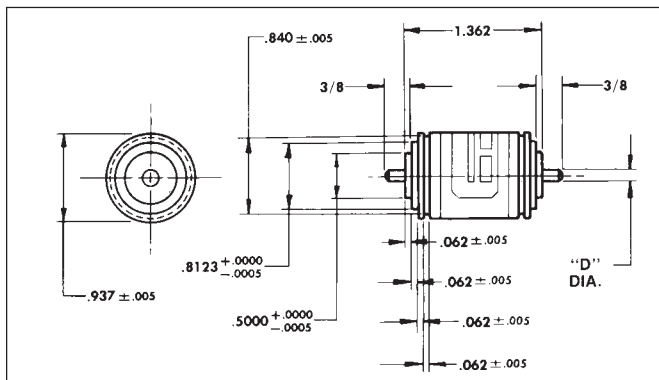

"D" DIMENSION

Inch	.1250 +.0000 / -.0005
Metric	2.993 +.000 / -.005

Ball Bearings Throughout Unit.
 Max. Rated Output Torque: 40 Oz. in.
 Backlash through entire gear train less than 30'

No. of Gear Clusters	Shaft Direction of Rotation	Gear Ratio	Inch Part No.	Metric Part No.
1	Same	9.50:1	U1-1	MSR1-1
2	Opposite	20.19:1	U1-2	MSR1-2
		30.08:1	U1-3	MSR1-3
3	Same	39.86:1	U1-4	MSR1-4
		50.14:1	U1-5	MSR1-5
		75.14:1	U1-6	MSR1-6
4	Opposite	100.56:1	U1-7	MSR1-7
		150.42:1	U1-8	MSR1-8
5	Same	199.50:1	U1-9	MSR1-9
		301.67:1	U1-10	MSR1-10
6	Opposite	400.73:1	U1-11	MSR1-11
		502.78:1	U1-12	MSR1-12
6	Opposite	1000.27:1	U1-13	MSR1-13
		2003.39:1	U1-14	MSR1-14
		3025.07:1	U1-15	MSR1-15

For Special Ratios, Consult Factory.

Sold & Serviced By:



Toll Free Phone (877) SERV098
 Toll Free Fax (877) SERV099
www.electromate.com
sales@electromate.com

PRECISION SPEED REDUCER

Inch and Metric Input and Output Shafts ■ 1 1/16" Dia. ■ Size 11

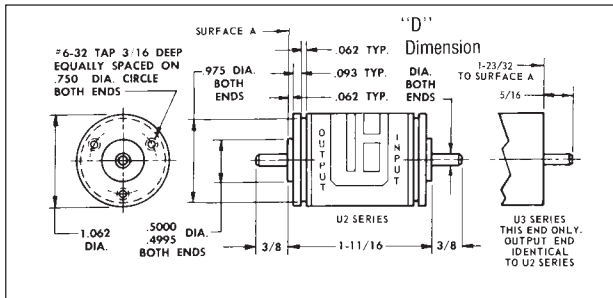

"D" DIMENSION

Inch	.1250 +.0000 -.0005
Metric	2.993 +.000 -.005

Ball Bearings Throughout Unit.
Max. Rated Output Torque: 65 Oz. in.
Backlash through entire gear train less than 30'.

No. of Gear Clusters	Shaft Direction of Rotation	*Gear Ratio (Exact)	Inch Part No.**	Inch Part No.***	Metric Part No.**
1	Same	9:1	U2-1	U3-1	MSR2-1
		10:1	U2-2	U3-2	MSR2-2
		12:1	U2-3	U3-3	MSR2-3
		15:1	U2-4	U3-4	MSR2-4
		20:1	U2-5	U3-5	MSR2-5
25:1	U2-6	U3-6	MSR2-6		
2	Opposite	30:1	U2-7	U3-7	MSR2-7
3	Same	40:1	U2-8	U3-8	MSR2-8
		50:1	U2-9	U3-9	MSR2-9
2	Opposite	60:1	U2-10	U3-10	MSR2-10
3	Same	80:1	U2-11	U3-11	—
		90:1	U2-12	U3-12	—
		100:1	U2-13	U3-13	MSR2-11
		180:1	U2-14	U3-14	MSR2-12
4	Opposite	200:1	U2-15	U3-15	MSR2-13
		300:1	U2-16	U3-16	MSR2-14
		360:1	U2-17	U3-17	MSR2-15
		400:1	U2-18	U3-18	MSR2-16
		500:1	U2-19	U3-19	—
5	Same	600:1	U2-20	U3-20	MSR2-17
		800:1	U2-21	U3-21	—
		1000:1	U2-22	U3-22	MSR2-18
6	Opposite	2000:1	U2-23	U3-23	—
		3000:1	U2-24	U3-24	MSR2-19
5	Same	3600:1	U2-25	U3-25	MSR2-20

**Shaft length is 3/8 in.

***Shaft length is 5/16 in.

For Special Ratios, Consult Factory.

PRECISION SPEED REDUCER

Inch and Metric Input and Output Shafts ■ 1 3/4" Dia. ■ Size 18

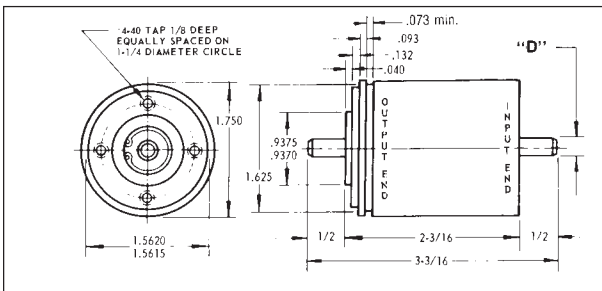

"D" DIMENSION

Inch	.2500 +.0000 -.0005
Metric	5.993 +0.000 -.005

Ball Bearings Throughout Unit.
Max. Rated Output Torque: 125 Oz. in.
Backlash through entire gear train less than 30'.

No. of Gear Clusters	Shaft Direction of Rotation	*Gear Ratio	Inch Part No.	Metric Part No.
1	Same	4.96:1	U4-1	MSR3-1
		6:1	U4-2	MSR3-2
2	Opposite	9.93:1	U4-3	MSR3-3
		15.27:1	U4-4	MSR3-4
1	Same	20:1	U4-5	MSR3-5
2	Opposite	30:1	U4-6	MSR3-6
		40:1	U4-7	MSR3-7
		50.9:1	U4-8	MSR3-8
		80:1	U4-9	MSR3-9
		100:1	U4-10	MSR3-10
3	Same	124.8:1	U4-11	—
		150:1	U4-12	MSR3-11
		200:1	U4-13	MSR3-12
		248.16:1	U4-14	MSR3-13
		300.3:1	U4-15	—
		400:1	U4-16	MSR3-14
4	Opposite	500:1	U4-17	MSR3-15
		600:1	U4-18	MSR3-16
6	Opposite	1000:1	U4-19	MSR3-17
		1600:1	U4-20	MSR3-18
4	Opposite	1800:1	U4-21	—
4	Opposite	2000:1	U4-22	—
5	Same	2300:1	U4-23	—
4	Opposite	2500:1	U4-24	MSR3-19
5	Same	3000:1	U4-25	MSR3-20

Sold & Serviced By:



Toll Free Phone (877) SERV098

Toll Free Fax (877) SERV099

www.electromate.com

sales@electromate.com

*For Special Ratios, Consult Factory.

PRECISION GEAR HEADS

1 1/16" Dia. ■ Size 11

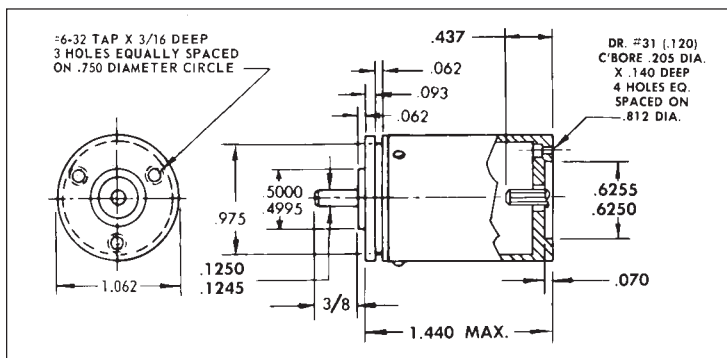

MOTOR PINION DATA

Number of Teeth	13
Diametral Pitch	120
Pressure Angle	20°
Testing Pitch Radius	.0542 .0530
Outside Diameter	.1247

Ball Bearings Throughout Unit.
 Max. Rated Output Torque: 65 Oz. in.
 Backlash through entire gear train less than 30'
 Motor and Pinion Supplied by Customer.

No. of Gear Clusters	Shaft Direction of Rotation	*Gear Ratio	Part No.
1	Same	7.23:1	U7-1
		10.85:1	U7-2
		14.46:1	U7-3
		18.08:1	U7-4
2	Opposite	21.69:1	U7-5
3	Same	36.15:1	U7-6
2	Opposite	43.39:1	U7-7
3	Same	65.08:1	U7-8
		72.31:1	U7-9
		130.15:1	U7-10
4	Opposite	144.62:1	U7-11
		216.92:1	U7-12
		260.31:1	U7-13
		289.23:1	U7-14
		361.54:1	U7-15
5	Same	433.85:1	U7-16
		578.46:1	U7-17
		723.08:1	U7-18
		1446.15:1	U7-19
6	Opposite	2169.23:1	U7-20
5	Same	2603.08:1	U7-21
		3253.85:1	U7-22

*For Special Ratios, Consult Factory.

PRECISION GEAR HEADS

1 3/4" Dia. ■ Size 18

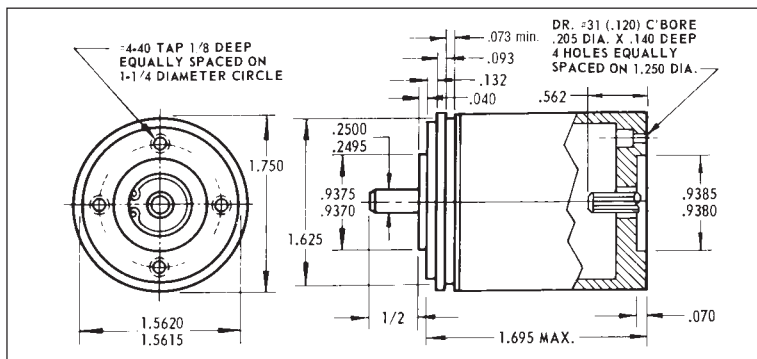

MOTOR PINION DATA

Number of Teeth	15
Diametral Pitch	96
Pressure Angle	20°
Testing Pitch Radius	.0781 .0769
Outside Diameter	.1765

Ball Bearings Throughout Unit.
 Max. Rated Output Torque: 125 Oz. in.
 Backlash through entire gear train less than 30'
 Motor and Pinion Supplied by Customer.

No. of Gear Clusters	Shaft Direction of Rotation	*Gear Ratio	Part No.
1	Same	7.67:1	U8-1
		16.80:1	U8-2
2	Opposite	25.20:1	U8-3
		33.60:1	U8-4
		42.76:1	U8-5
		67.20:1	U8-6
		84.00:1	U8-7
3	Same	104.90:1	U8-8
		126.00:1	U8-9
		168.00:1	U8-10
		208.46:1	U8-11
		252.26:1	U8-12
		336.00:1	U8-13
4	Opposite	420.00:1	U8-14
		504.00:1	U8-15
		840.00:1	U8-16
		1344.00:1	U8-17
5	Same	1680.00:1	U8-18
		2100.00:1	U8-19
		2520.00:1	U8-20
6	Opposite	3360.00:1	U8-21

*For Special Ratios, Consult Factory.

Sold & Serviced By:

 Toll Free Phone (877) SERV098
 Toll Free Fax (877) SERV099
www.electromate.com
sales@electromate.com

PRECISION SERVO GEAR BOXES

1/4" Shaft ■ Ratios From 2:1 To 625:1 ■ ABEC-7 Ball Bearings

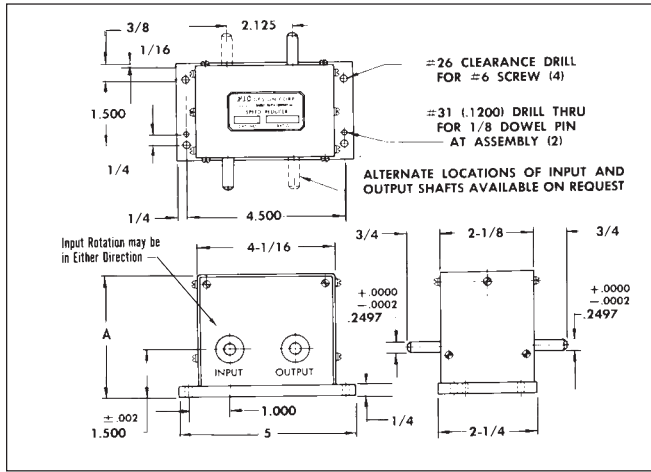

Material: Gears — 2024-T4 Aluminum Meshing
with 303 Stainless Steel Pinions
Housing — Aluminum (Black Anodize)

OPERATING CHARACTERISTICS

All Units Lubricated with
Mil Spec. Oil and Grease.

Maximum Speed	5,000 rpm
Static Torque Rating Output (Max.)	500 oz. in.
Backlash as Measured at Output Shaft with Input Shaft Locked	30'

Exact Ratio	Direction of Rotation	A	Part No.
2:1	Same	3-9/32	ES-1
3:1			ES-2
4:1			ES-3
5:1			ES-4
6:1			ES-5
7:1	Same	3-9/32	ES-6
8:1			ES-7
9:1			ES-8
10:1			ES-9
12:1			ES-10
15:1	Same	3-9/32	ES-11
16:1			ES-12
20:1			ES-13
25:1			ES-14
30:1	Opposite	3-13/16	ES-15
32:1			ES-16
36:1			ES-17
40:1			ES-18
45:1			ES-19
48:1	Opposite	3-13/16	ES-20
50:1			ES-21

Exact Ratio	Direction of Rotation	A	Part No.
60:1	Opposite	3-13/16	ES-22
64:1			ES-23
75:1			ES-24
80:1			ES-25
100:1	Opposite	3-13/16	ES-26
125:1			ES-27
72:1			Same
90:1	ES-29		
96:1	ES-30		
128:1	ES-31		
150:1	ES-32		
180:1	Same	4-13/16	ES-33
200:1			ES-34
250:1			ES-35
256:1			ES-36
300:1	Same	4-13/16	ES-37
375:1			ES-38
400:1			ES-39
500:1			ES-40
625:1			ES-41

Oil-Impregnated Bronze Bearings Available, Consult Factory.

Precision Servo Gear Boxes with Anti-Backlash Gears, Special Ratios, Available, Consult Factory.

WORM & WHEEL ASSEMBLIES — 48 & 64 PITCH

Shafts ■ ABEC-7 Ball Bearings ■ 1/4" to 3/16" Shafts

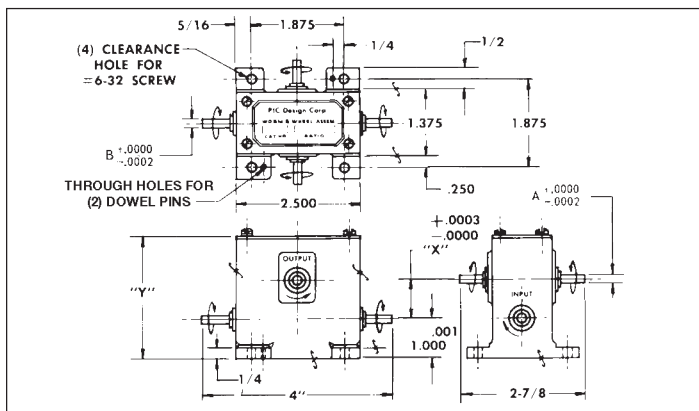

Material: Housing — Cast Aluminum (Anodized)
Worm — Stainless Steel
Wheel — Bronze
All Other Parts Stainless Steel
Lubricated with Mil-Spec. Oil & Grease.

OPERATING CHARACTERISTICS

All Units Lubricated with
Mil Spec. Oil and Grease.

Maximum Speed	2,000 rpm
Static Torque Rating 48 Pitch	200 in. oz.
Static Torque Rating 64 Pitch	150 in. oz.
Backlash Through Entire Train Less Than	30'
Units Can Only be Driven at Input Shaft — Cannot be Used as Speed Increaser.	
Input Shaft may be Turned Either Direction.	

Pitch	Exact Ratio	A	B	X	Y	Part No.
48	12.5:1	.2497	.1872	.6878	2-11/32	DJ-1
	15:1			.7920	2-35/64	DJ-2
	20:1			1.0003	2-31/32	DJ-3
	22.5:1			1.1045	3-11/64	DJ-4
	25:1			.6878	2-11/32	DJ-5
	30:1			.7920	2-35/64	DJ-6
	40:1			1.0003	2-31/32	DJ-7
	45:1			1.1045	3-11/64	DJ-8
	50:1			.6878	2-11/32	DJ-9
	60:1			.7920	2-35/64	DJ-10
	80:1			1.0003	2-31/32	DJ-11
	90:1			1.1045	3-11/64	DJ-12
64	15:1	.2497	.2497	.7190	2-11/32	DQ-1
	20:1			.8753	2-5/8	DQ-2
	25:1			1.0315	2-31/32	DQ-3
	30:1			1.1878	3-1/4	DQ-4
	30:1			.7190	2-11/32	DQ-5
	40:1			.8753	2-5/8	DQ-6
	50:1			1.0315	2-31/32	DQ-7
	60:1			1.1878	3-1/4	DQ-8
	60:1			.7190	2-11/32	DQ-9
	80:1			.8753	2-5/8	DQ-10
	100:1			1.0315	2-31/32	DQ-11
	120:1			1.1878	3-1/4	DQ-12

Other Shaft Diameters Available, Consult Factory.

Oil-Impregnated Bearings Available, Consult Factory.

METRIC SERVO GEAR BOXES

All Dimensions In Millimeters

Shaft Diameter 6mm ■ Ratio 2:1 To 625:1

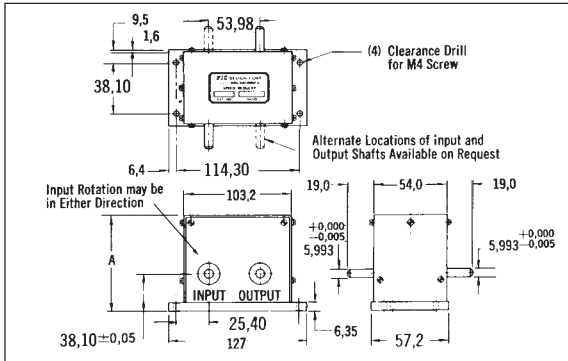

Gear Ratio	Shaft Direction of Rotation	A	Part No.
2:1	Same	83.3	MGB3-1
3:1			MGB3-2
4:1			MGB3-3
5:1			MGB3-4
6:1			MGB3-5
10:1	Same	83.3	MGB3-6
12:1			MGB3-7
15:1			MGB3-8
16:1	Same	83.3	MGB3-9
20:1			MGB3-10
25:1			MGB3-11
30:1			MGB3-12
36:1	Opposite	96.8	MGB3-13
40:1			MGB3-14

Special Shaft Sizes or Ratios Available, Consult Factory.
Available With Anti-Backlash Gears, Consult Factory.

Gear Ratio	Shaft Direction of Rotation	A	Part No.
50:1	Opposite	96.8	MGB3-15
60:1			MGB3-16
80:1	Opposite	96.8	MGB3-17
100:1			MGB3-18
150:1	Same	122.2	MGB3-19
200:1	Same	122.2	MGB3-20
300:1			MGB3-21
400:1	Same	122.2	MGB3-22
500:1			MGB3-23
625:1			MGB3-24

OPERATING CHARACTERISTICS

Maximum Speed 5,000 rpm
Static Torque Rating Output (Max.) 3.54 N-m
Backlash as Measured at Output
Shaft with Input Shaft Locked 30' Max.
Ball Bearing Tolerance ABEC-7

Material: Gears — Aluminum Meshing with
Stainless Steel Pinions
Housing — Aluminum (Black Anodize)

INTERMITTENT MOTION ASSEMBLY

48 Pitch Gears ■ 1/4" Shaft

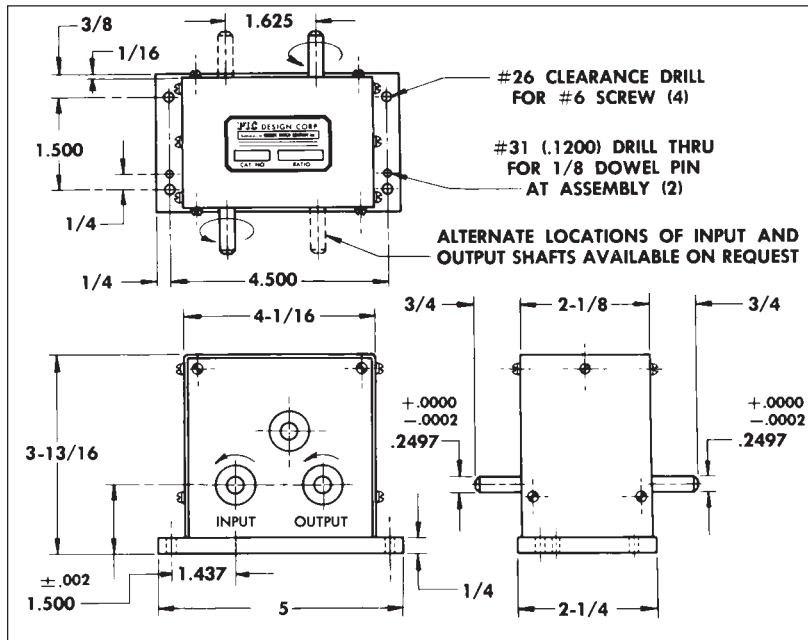

MATERIAL SPECIFICATIONS

Gears: 2024-T4 Aluminum Meshing with
303 Stainless Steel
Geneva: 303 Stainless Steel
Housing: Aluminum — Black Anodized
Lubricated with Mil Spec. Oil and Grease

OPERATING CHARACTERISTICS

Maximum Speed — 300 rpm
Input Travel — Either Direction and Reversible.
Backlash as Measured at Output Shaft with
Input Shaft Locked — 30'

*Degrees of Output Per Each Full Revolution of Input	Part No.
90°	EV-1
60°	EV-2
45°	EV-3
30°	EV-4
22° 30'	EV-5
10°	EV-6

*2 Cam Followers on Driver Available, Consult Factory.
Special Output Angles, Shaft Sizes and Shaft Locations Available, Consult Factory.
Intermittent Motion Assemblies Available with Oil-Impregnated Bearings, Consult Factory.
Lightening Holes Optional, Consult Factory.

Sold & Serviced By:

ELECTROMATE

Toll Free Phone (877) SERV098

Toll Free Fax (877) SERV099

www.electromate.com

sales@electromate.com

GENEVA MECHANISMS

Intermittent Motion ■ 1/4" Shaft ■ 72° Motion

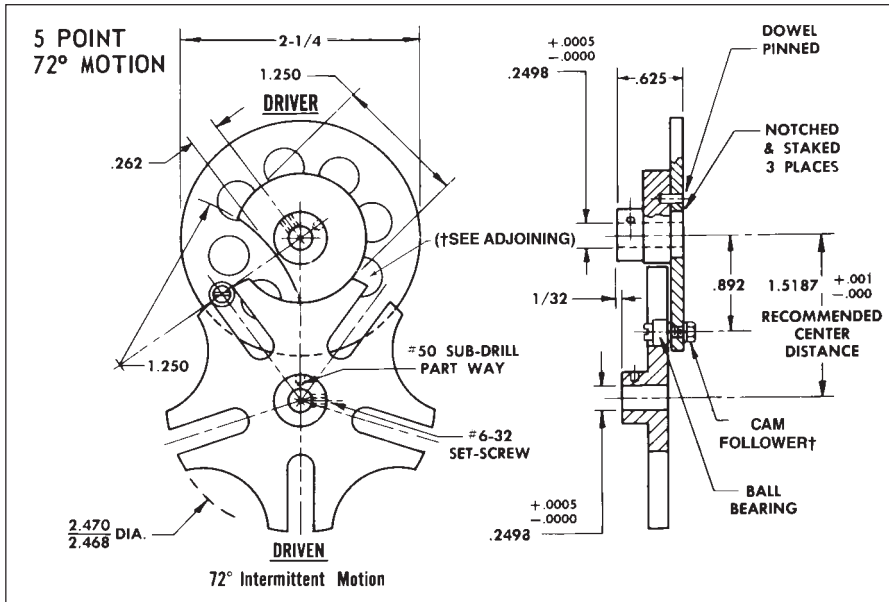

No. of Points	Intermittent Motion	Part No.
5	360° Driver = 72° Driven	EU-2

Driver Travel — Either Direction and Reversible
1/8" & 3/16" Shaft Units Available, Consult Factory.

*Lighting Holes
Optional, on Request.

†2 Cam Followers
on Driver Available
on Request.

Material: 303 Stainless Steel

GENEVA MECHANISMS

Intermittent Motion ■ 1/4" Shaft ■ 90° Motion

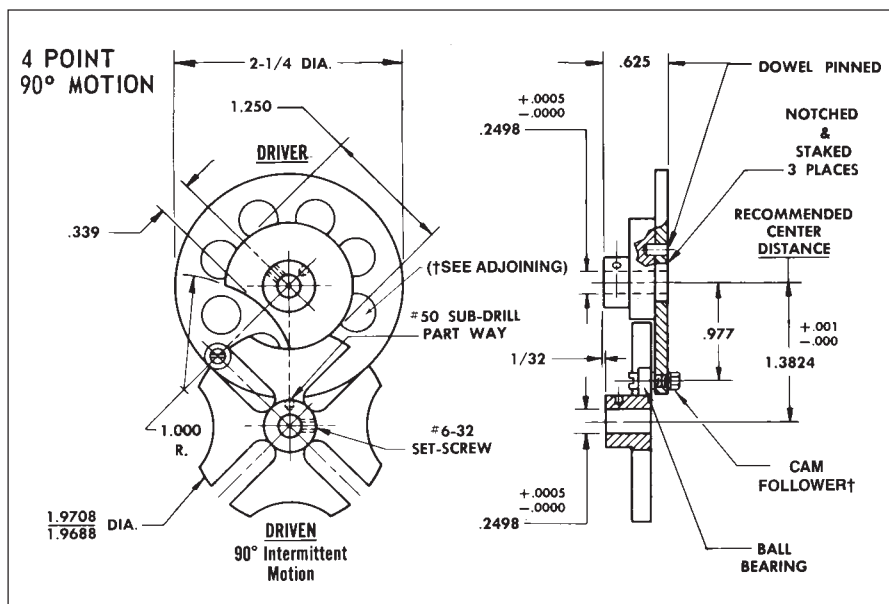

No. of Points	Intermittent Motion	Part No.
4	360° Driver = 90° Driven	EU-1

Driver Travel — Either Direction and Reversible
1/8" & 3/16" Shaft Units Available, Consult Factory.

*Lighting Holes
Optional, on Request.

†2 Cam Followers
on Driver Available
on Request.

Material: 303 Stainless Steel

Sold & Serviced By:

 **ELECTROMATE**

Toll Free Phone (877) SERV098

Toll Free Fax (877) SERV099

www.electromate.com

sales@electromate.com

GENEVA MECHANISMS

Intermittent Motion ■ 1/4" Shaft ■ 45° Motion

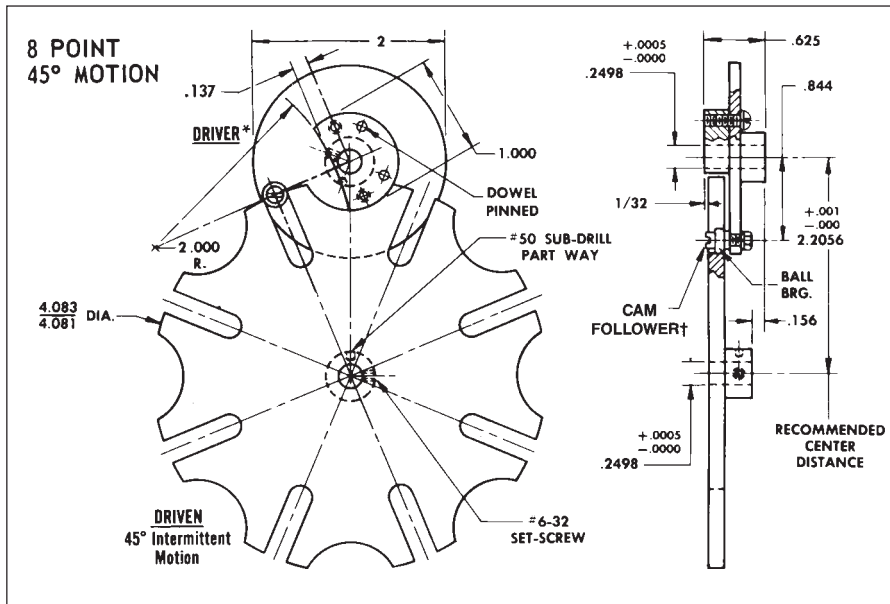

Material: 303 Stainless Steel

No. of Points	Intermittent Motion	Part No.
8	360° Driver = 45° Driven	EU-4

Driver Travel — Either Direction and Reversible
1/8" & 3/16" Shaft Units Available, Consult Factory.

*Lighting Holes
Optional, on Request.

†2 Cam Followers
on Driver Available
on Request.

GENEVA MECHANISMS

Intermittent Motion ■ 1/4" Shaft ■ 60° Motion

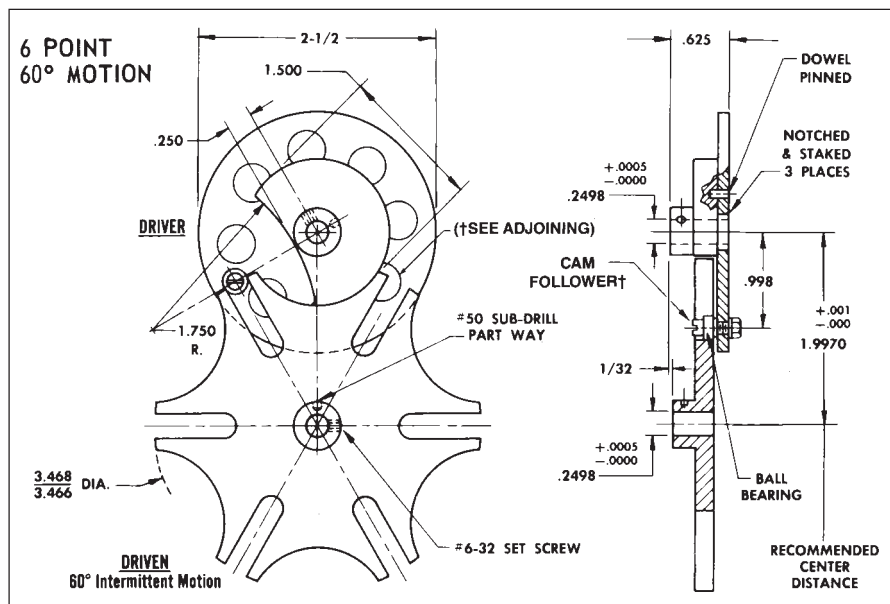

Material: 303 Stainless Steel

No. of Points	Intermittent Motion	Part No.
6	360° Driver = 60° Driven	EU-3

Driver Travel — Either Direction and Reversible
1/8" & 3/16" Shaft Units Available, Consult Factory.

*Lighting Holes
Optional, on Request.

†2 Cam Followers
on Driver Available
on Request.

Sold & Serviced By:

 **ELECTROMATE**

Toll Free Phone (877) SERV098

Toll Free Fax (877) SERV099

www.electromate.com

sales@electromate.com