

# LINEAR SLIDES

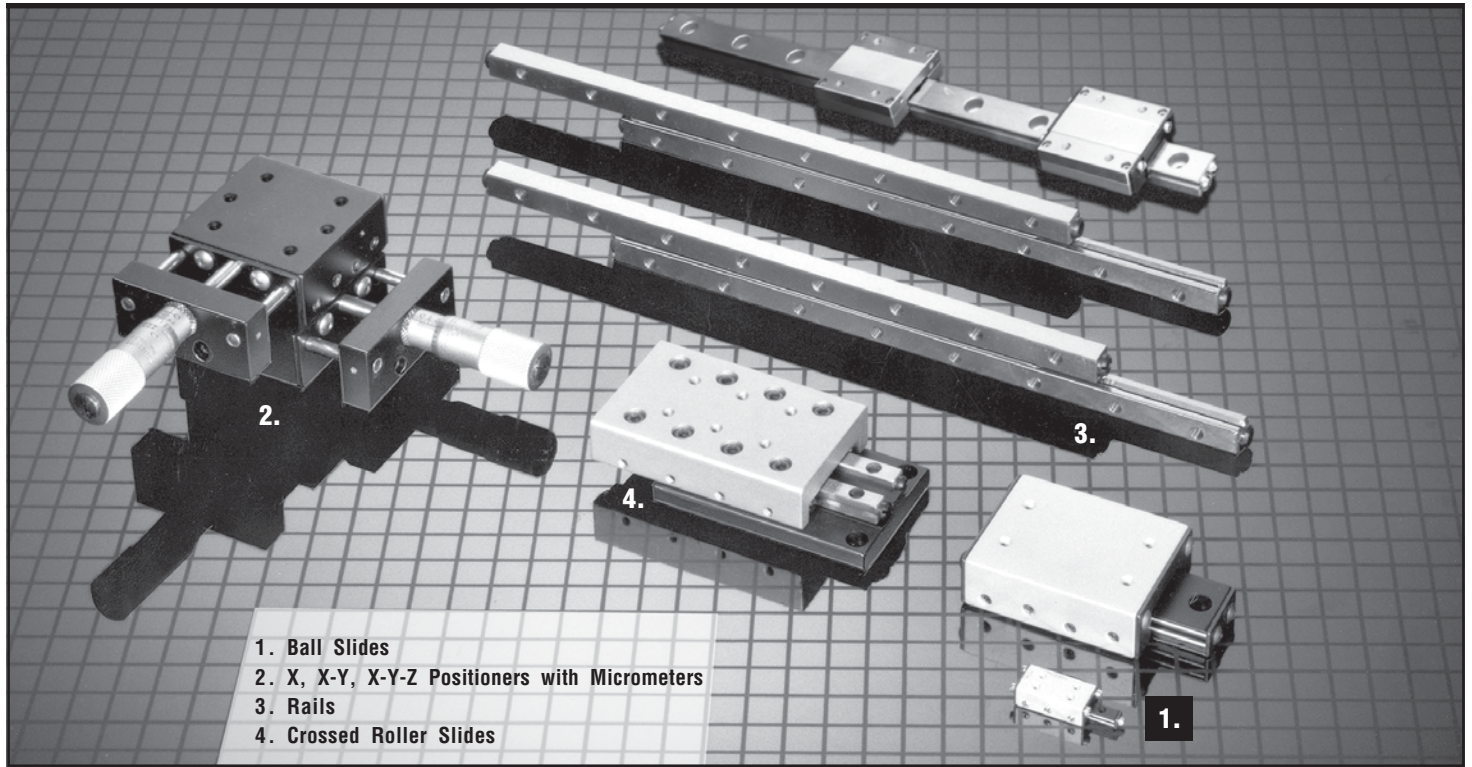

PIC Design has added several new linear slide products to its line of precision Ball Slides. For higher load carrying capability and higher accuracy, a line of crossed roller rails and slides has been added. The Ball Slide line has been expanded to include additional sizes and PIC now offers a line of X, XY and XYZ Positioners with micrometers.

## PIC Linear Slides — a brief overview.

### BALL SLIDES

Precision Ball Slides assemblies are used as guides and supports in various applications providing low friction and high accuracy for precise, linear, uniform movement. The wide range of sizes and load carrying capabilities enables the designer or engineer to select the appropriate ball slide for the particular application. Ball slides are used in many applications, such as assembly fixtures, packaging machinery, medical and optical instruments, computer disk drives and printers, copiers and other precision equipment.

The slides low friction is due to the hardened stainless steel balls rolling between ground hardened rods, providing low starting and rolling friction for moving light and heavy loads. The high accuracy is attributed to the aluminum bodies having flat,

smooth top and bottom surfaces. Riding parallel to the line of motion, they provide straight line accuracy to .0005" per inch of travel. The assembled units are preloaded to prevent side play and backlash and to ensure positional repeatability to .0002" to maintain precise, uniform, linear movement.

### POSITIONERS WITH MICROMETERS

The positioners are supplied assembled and feature low friction, high accuracy and repeatability as do the ball slides. PIC positioners are supplied for multi-axis applications, "X", "XY" and "XYZ" configurations. Spring loaded micrometer drives allow precise repeatable adjustments with low friction and zero backlash. (Micrometers available in inch or metric units) The product line includes the subminiature series which contains the smallest commercially available positioner and the standard series which is ideal for most gaging and positioning applications, such as measuring instruments and optical assemblies.

### RAILS

Rails, also referred to as Crossed Roller Linear Bearings Sets, are compact precision bearings that can support and guide high loads with high accuracy and repeatability, low friction and low starting force. Each bearing consists of a pair of hardened steel ways containing 90° vee grooves and a row of alternately crossed cylindrical rollers. The

hardened steel rollers are captive in a brass cage for easy handling and assembly and permanent alignment. These ways are installed face to face with the rollers between the vee grooves, so that the user can mount in any direction or orientation to fulfill the application without adding a whole slide to the system. Rails are sold in sets consisting of two bearings (4 way bars, 2 roller cages and end stops).

### CROSSED ROLLER SLIDES

The crossed roller slides incorporate the rails to provide precise linear motion with low friction at a higher load carrying capability than ball slides. The crossed roller slides are available in either a steel or aluminum body. The steel crossed roller slides offer a high support stiffness for the load, thus resulting in a straight line accuracy of .00008" over 4 inches of length and .00012 over 12.5" of length. The aluminum crossed roller slides offer low cost and lightweight body that may be necessary in weight sensitive applications. The straight line accuracy of the aluminum slide is .0001" per inch of travel.

The steel or the aluminum crossed roller slides are available in a variety of sizes for applications including precision instruments, office and communications equipment, surface and tool grinders, assembly fixtures and other applications which require precise, uniform linear motion.

# TECHNICAL SECTION

PIC Design has included a straight line accuracy table to select the type of linear slide that will meet the accuracy required by the particular application. Straight line accuracy is the amount of deflection over the center line of the carriage and parallel to the line of motion. Also included are the maximum travel and maximum load capacity of each series of Ball Slides, X-XY-XYZ positioners with micrometer, aluminum and steel crossed roller slides.

**STRAIGHT LINE ACCURACY TABLE**

ACCURACY	TYPE
.0005 in/in	Ball Slides
.0005 in/in	Positioners
.00008 in/in	Steel Crossed Roller Slides
.0001 in/in	Aluminum Crossed Roller Slides

## BALL SLIDES

SERIES		FEATURES	
		Travel	Load
PB04	Smallest commercially available ball slides. Long life and high accuracy for computer disk drives, printers, plotters, and copiers.	0.5" -1.5"	1.5 lb.
PB05	Same accuracy as larger slides. Ideal for compact instruments.	0.5" -5.0"	4-18 lb.
PB08	Compact profile for restricted spaces, yet high load capacity.	0.5" -5.0"	8-18 lb.
PB1	Popular series meets many needs with moderate travel requirements. Wider profile for good load support.	0.5" -3.0"	10-18 lb.
PB12	Heavier balls and ways provide high load capacity and long travel for controls, other medium duty applications.	0.75" -8.0"	15-40 lb.
PB15	Larger slides for heavy loads with no sacrifice in life, accuracy, and repeatability.	1.0" -8.0"	15-55 lb.
PB2	Rugged slides for high loads, very short overall lengths.	1.0" -8.0"	20-90 lb.
PB3	Widest profile for longest travel, highest capacity.	1.00" -12.0"	35-205 lb.

## X, XY, XYZ POSITIONERS WITH MICROMETERS

SERIES		FEATURES	
		Micrometer	Load
100, 200	Subminiature ball slides only .38" high with miniature micrometer drives, for restricted space applications.	0.50"	4 lb.
300	Heavy duty subminiature series. Standard and low profile XYZ models.	0.50"	12 lb.
400, 450 500	Popular standard series meets majority of gaging and positioning needs. Low profile XYZ model included.	0.50", 1.0" 13mm, 25mm	20-42 lb.
1200, 2200	Standard duty series with oversize table area. Standard and low profile XYZ models.	1.0"	30 lb.

## ALUMINUM CROSSED ROLLER SLIDES

SERIES		FEATURES	
		Max. Travel in. (mm)	Max. Load lbf (kgf)
PNBT-1000A	The same 1.5mm roller used in the PNBT-1000 series is utilized, but is a lighter weight and lower cost carriage with extended travel.	3 (76)	198 (90)
PNBT-2000A	The 2mm crossed roller rail set with a larger profile than the 1000A series.	3 (76)	198 (90)
PNBT-3000A	The 3mm roller has the same travel as the PNBT-2000A, but more than twice the load carrying capability.	3 (76)	477 (216)
PNBT-4000A	The 4mm set of crossed roller rails offers 25% more travel with 25% more load carrying capability than the PNBT-3000A series.	4 (102)	723 (328)

## STEEL CROSSED ROLLER SLIDES

SERIES		FEATURES	
		Max. Travel in. (mm)	Max. Load lbf (kgf)
PNBT-1000	The smallest slide of the line utilizing a set of the 1.5mm crossed roller rails.	1.260 (32)	57 (26)
PNBT-2000	A series with 25% more width of carriage with almost 10X the load carrying capacity of the PNBT-1000 series.	1.969 (50)	209 (95)
PNBT-3000	The 3mm crossed roller rail set profile with same straight line accuracy as the smaller series.	3.543 (90)	682 (310)
PNBT-4000	The 4mm roller slide maintains the high straight line accuracy with a high load carrying capability.	4.134 (105)	1034 (470)
PNBT-6000	The 6mm roller slide is capable of carrying heavy loads over 10" of travel.	10.43 (265)	3223 (1462)

Typical coefficient of friction is .003

Sold & Serviced By:



Toll Free Phone (877) SERV098  
Toll Free Fax (877) SERV099  
[www.electromate.com](http://www.electromate.com)  
[sales@electromate.com](mailto:sales@electromate.com)

When designing a system that requires the use of linear motion, the straight line accuracy, as well as the repeatability, stiffness and the cost of the linear slide should be looked at. PIC has included a brief but informative description of the types of linear slides included, so that the proper linear slide will be selected for a particular application.

Ball Slides generally are used in reciprocating applications requiring 12" or less of travel and loads below 200 lbs. They are comparable in accuracy to linear ball bushings and offer less complexity and less cost than ball bushings within the same travel range. The Ball Slides are capable of high speed and long life with no lubrication and are not affected by common industrial contaminants.

The Positioners with micrometers are used in applications which are static or the motion is intermittent, with repeatability being most significant. The positioners can be located in the X, X-Y or X-Y-Z axes with little modification needed.

The crossed roller slide performs the same function as ball slides, but are capable of higher accuracy and loads. The crossed roller slide may be preloaded more heavily than a ball slide and still maintain low friction. The steel crossed roller slide will be 4 times as stiff or 1/4 the axial play and have 10 times the load capacity of a similar size ball slide. The aluminum crossed roller slide utilizes the same rails as the steel crossed rollers, but are lighter in weight, therefore sacrificing stiffness and accuracy, but are more economical.

The crossed roller slides reduce the installation complexity if they can be accommodated into the system. The rails are used for applications that require the high accuracy of the crossed rollers with the mounting and carriage bases being a part of the application.

## BALL AND CROSSED ROLLER SLIDES AND POSITIONERS

### Load Ratings and Life Estimates

The rated load capacity on slides may be a mass load on a horizontal slide, or a force load normal to the mounting surface in any position. The rated load must be centered and distributed over the slide, and the base must be fully supported on a flat mounting surface so that the slide does not act as a beam subject to concentrated or distributed bending forces. Loads supported by protruding arms reduce accuracy and load capacity by acting as levers or ratio arms, and should be avoided even when load forces are small. When used at the rated load capacity and moderate speeds, a life of 10 million inches of travel can be expected. The expected life at one half the rated load is 100 million inches.

### Friction and Lubrication

The coefficient of friction is lower for linear bearings than for rotary bearings, where the peripheral track is shorter on the inner race than on the outer race, causing the ball or roller to skid on one or the other. The balls or rollers run exactly equal distances on the pair of tracks in linear bearings, permitting the balls or rollers to run without friction, wear, or skidding at any preload. The typical coefficient of friction for ball slides is .003.

The slides are lightly lubricated during assembly, and are self-cleaning in normal service. Additional lubrication is required for speeds above 1800 inches/min., and is advisable at lower speeds where high loads are applied in continuous duty applications.

### Mounting and Accuracy

The mounting surfaces of the slides are machined flat and smooth, and parallel to each other and the line of motion. They must be mounted on smooth, flat supports that will not deflect under load. Especially with long slides of small cross section, binding may be caused by distortion of the bottom member when mounted on

irregular surfaces. If so, round shims or spacers may be placed over the mounting screws to raise the slide above the surface asperities. Bedding in epoxy resin is also recommended.

### Modifying Length of Travel for Rails

For a given length of bearing way, since there is no slip at any load, both length of travel and load capacity depend on the number of rollers and their pitch. The number of rollers supplied with each standard bearing set provides a travel distance of approximately 60% of the way length.

In some cases (e.g., when mounting space is restricted) it may be practical to increase travel at the expense of load capacity by removing one or more rollers instead of selecting a longer bearing. Since travel extends symmetrically around the mean position, the travel increase is twice the pitch for each roller removed. Similarly, the load capacity for the set is reduced by twice the load capacity per roller.

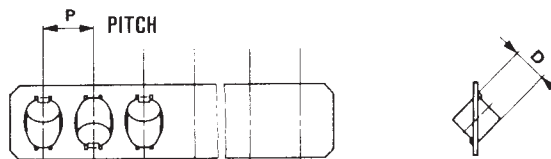

Roller Diameter (D) in (mm)	Roller Distance (P) in (mm)	Increase of Travel for Each Roller Cut-Off in (mm)	Roller Load Carrying Capacity Per Roller lbs (kg)
.059 (1.5)	.098 (2.5)	.197 (5)	8.8 (4)
.079 (2)	.158 (4)	.316 (8)	13.2 (6)
.118 (3)	.197 (5)	.394 (10)	22.0 (10)
.158 (4)	.275 (7)	.550 (14)	44.0 (20)
.236 (6)	.334 (8.5)	.668 (17)	88.0 (40)

### Mounting The Rail Sets

In mounting of the rail sets, the maximum deviation from parallelism between the two surfaces should not exceed the value listed in the chart below according to the length of rail. The mounting and banking surfaces must be smooth and flat and accurately parallel, coplanar or perpendicular respectively to achieve maximum accuracy of the rail set.

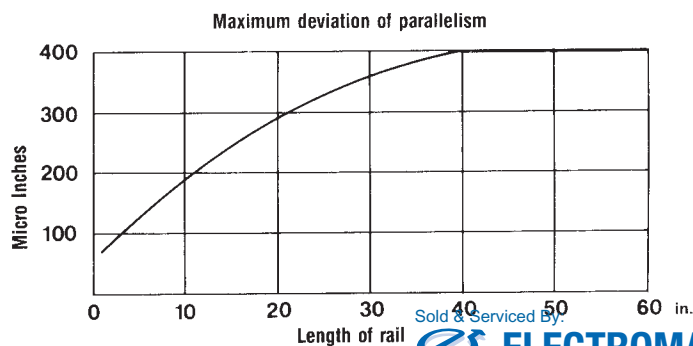

**Maximum Operating Temperature: 100°C(212°F)**



# BALL SLIDES

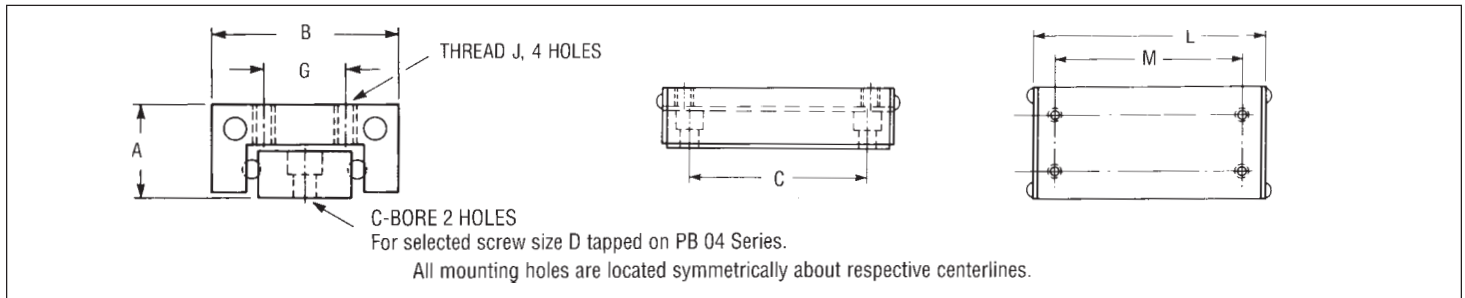

## Specifications

Straight line accuracy: .0005/inch of travel  
Repeatability: .0002

Material: Aluminum Base and Carriage  
Finish: Clear/Black Anodize - AT PIC Option

\* Minimum, centered around mean position.  
Typical overtravel 0.06" each direction.

Total Travel*	Length L	Height A	Width B	Carriage Hole Spacing		Hole Spacing C	J	D	Load Capacity (lbs.)	Part Number
				M	G					
.50 1.00 1.50	.75 1.25 1.75	.23 .23 .23	.38 .38 .38	.375 .875 1.375	.156 .156 .156	.375 .875 1.375	2-56 2-56 2-56	2-56 2-56 2-56	1.5 1.5 1.5	PB04-05 PB04-10 PB04-15
.50 1.00 2.00 3.00 4.00 5.00	1.06 2.06 3.06 4.06 5.06 6.06	.32 .32 .32 .32 .32 .32	.56 .56 .56 .56 .56 .56	.625 1.625 2.625 3.625 4.625 5.625	.218 .218 .218 .218 .218 .218	.750 1.375 2.375 3.375 3.500 4.500	2-56 2-56 2-56 2-56 2-56 2-56	2-56 2-56 2-56 2-56 2-56 2-56	4 8 12 14 16 18	PB05-05 PB05-10 PB05-20 PB05-30 PB05-40 PB05-50
.50 1.00 2.00 3.00 4.00 5.00	1.06 2.06 3.06 4.06 5.06 6.06	.40 .40 .40 .40 .40 .40	.75 .75 .75 .75 .75 .75	.625 1.625 2.625 3.625 4.625 5.625	.375 .375 .375 .375 .375 .375	.750 1.375 2.375 3.375 3.500 4.500	4-40 4-40 4-40 4-40 4-40 4-40	4-40 4-40 4-40 4-40 4-40 4-40	8 10 12 14 16 18	PB08-05 PB08-10 PB08-20 PB08-30 PB08-40 PB08-50
.50 1.00 1.50 2.00 3.00	1.56 2.56 3.06 3.56 4.56	.50 .50 .50 .50 .50	1.00 1.00 1.00 1.00 1.00	1.250 2.250 2.750 3.250 4.250	.437 .437 .437 .437 .437	1.250 2.250 2.750 3.250 4.250	6-32 6-32 6-32 6-32 6-32	4-40 4-40 4-40 4-40 4-40	10 12 13 15 18	PB1-05 PB1-10 PB1-15 PB1-20 PB1-30
.75 1.50 2.00 3.00 4.00 6.00 8.00	1.56 2.56 3.56 4.56 6.00 8.00 10.00	.53 .53 .53 .53 .53 .53 .53	1.06 1.06 1.06 1.06 1.06 1.06 1.06	1.250 2.250 3.250 4.000 5.500 7.500 9.500	.437 .437 .437 .437 .437 .437 .437	1.125 2.125 3.125 3.250 4.000 5.000 7.000	6-32 6-32 6-32 6-32 6-32 6-32 6-32	6-32 6-32 6-32 6-32 6-32 6-32 6-32	15 18 20 25 30 35 40	PB12-08 PB12-15 PB12-20 PB12-30 PB12-40 PB12-60 PB12-80
1.00 2.00 3.00 4.00 6.00 8.00	2.00 3.00 4.00 6.00 8.00 10.00	.62 .62 .62 .62 .62 .62	1.50 1.50 1.50 1.50 1.50 1.50	1.375 2.375 3.375 5.375 7.375 9.375	.625 .625 .625 .625 .625 .625	1.500 2.500 3.500 4.000 5.000 7.000	6-32 6-32 6-32 6-32 6-32 6-32	6-32 6-32 6-32 6-32 6-32 6-32	15 20 25 35 45 55	PB15-10 PB15-20 PB15-30 PB15-40 PB15-60 PB15-80
1.00 1.50 2.00 3.00 4.00 6.00 8.00	2.00 2.75 3.25 4.00 6.00 8.00 10.00	.75 .75 .75 .75 .75 .75 .75	1.75 1.75 1.75 1.75 1.75 1.75 1.75	1.375 2.125 2.625 3.375 5.500 7.500 9.500	.875 .875 .875 .875 .875 .875 .875	1.625 2.250 2.750 3.500 4.000 5.000 7.000	6-32 6-32 6-32 6-32 6-32 6-32 6-32	6-32 6-32 6-32 6-32 6-32 6-32 6-32	20 30 42 52 60 75 90	PB2-10 PB2-15 PB2-20 PB2-30 PB2-40 PB2-60 PB2-80
1.00 1.50 2.00 3.00 4.00 5.00 6.00 9.00 12.00	2.62 2.62 4.00 5.00 6.00 8.00 9.00 12.00 15.00	1.00 1.00 1.00 1.00 1.00 1.00 1.00 1.00 1.00	2.62 2.62 2.62 2.62 2.62 2.62 2.62 2.62 2.62	2.125 1.625 3.000 4.000 5.000 7.000 3.000 typ. 3.000 typ. 3.000 typ.	1.250 1.250 1.250 1.250 1.250 1.250 1.250 1.250 1.250	2.125 1.875 3.375 4.375 5.375 7.375 7.000 10.000 13.000	10-32 10-32 10-32 10-32 10-32 10-32 10-32 10-32 10-32	10-32 10-32 10-32 10-32 10-32 10-32 10-32 10-32 10-32	30 35 62 88 118 135 150 185 205	PB3-10 PB3-15 PB3-20 PB3-30 PB3-40 PB3-50 PB3-60 PB3-90 PB3-120

# ECONOMY BALL SLIDES

For Linear Motion Applications

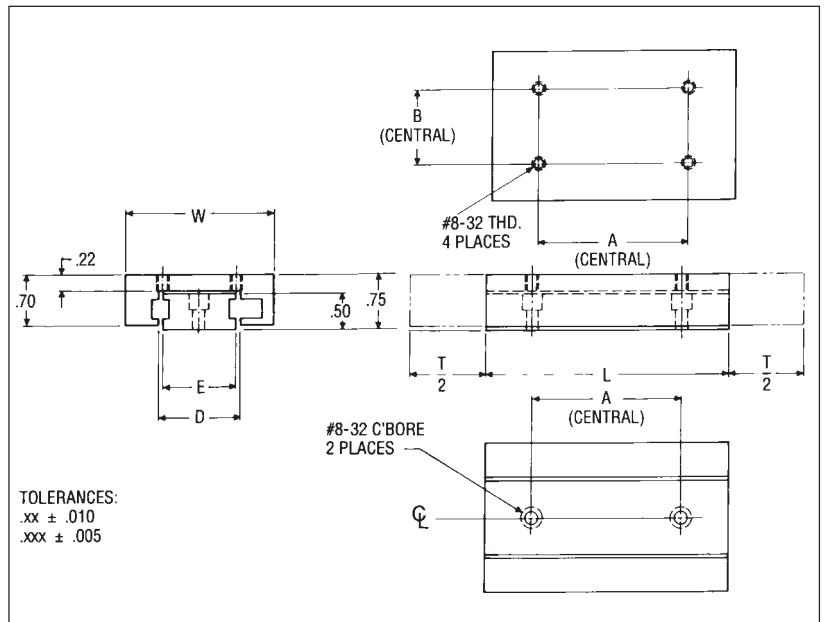

**Material:** Aluminum Base and Carriage

**Finish:** Black Anodize

**Specifications**

Straight line accuracy: .001" / inch of travel

Repeatability: .001

PIC's economy Ball Slides, with their unique conforming pre-loaded mechanism, provide economic solutions to linear motion applications where extreme accuracy is not required. These cost-effective slides provide the repeatability needed for most automation and robotic applications, without the need for expensive four-digit accuracy of conventional slides.

This unique PIC slide utilizes conventional, hardened rod raceways and balls, combined with a proprietary elastomer gib for even and continuous linear bearing preload. The conforming elastomeric bearing preload tends to negate the limited shock load separation of conventional linear ball slides with no degradation in reliability and at an economical cost.

Travel (In.)	W	L	A	B	D	E	Load Capacity (lbs)	Part No.
1.0		2.00	1.000				20	PBE-122
2.0	2.00	3.00	2.000	1.000	1.10	1.00	30	PBE-223
3.0		4.00	3.000				40	PBE-324
2.0		4.00	3.000				30	PBE-234
3.0		5.00	4.000				40	PBE-335
4.0	3.00	6.00	5.000	2.000	2.10	2.00	50	PBE-436
5.0		7.00	6.000				60	PBE-537
6.0		8.00	7.000				70	PBE-638

Sold & Serviced By:



Toll Free Phone (877) SERV098

Toll Free Fax (877) SERV099

www.electromate.com

sales@electromate.com

# ALUMINUM CROSSED ROLLER SLIDES

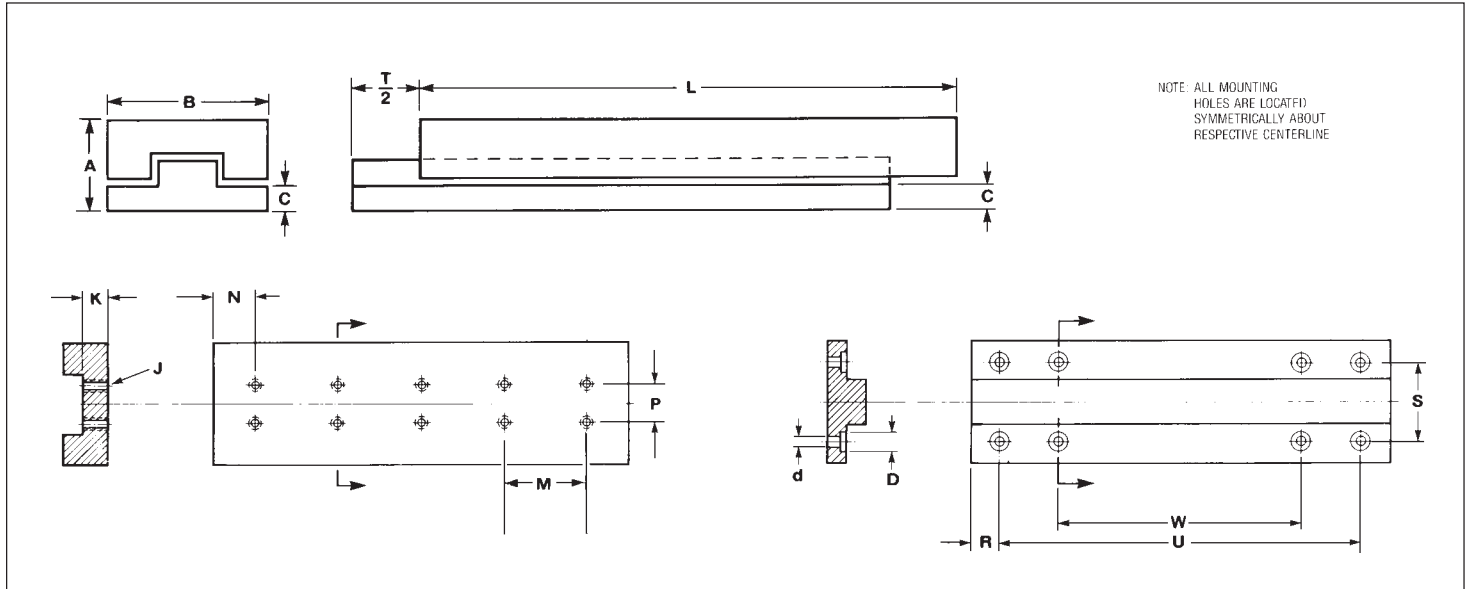

## Specifications

Straight line accuracy: .0001/inch of travel

Material: Aluminum Base and Carriage  
Hardened Steel Rails and Rollers

Finish: Carriage — Gold Anodize Base — Black Anodize

## Travel Length and Load Selection

Dimension in Inches (mm)		Carriage Mounting Holes (Threaded)			Base Mounting Holes (Counterbored)			Load Capacity		Part No.
Travel T	Length L	No. Holes	No. Spaces	Spacing M	No. Holes	Spacing U	Spacing W	LBF	Kgf	
1.00	1.969 (50)	4	1	.591 (15)	4	1.575 (40)	—	96	(44)	PNBT-1050A
1.50	2.559 (65)	6	2	.591 (15)	4	2.165 (55)	—	114	(52)	PNBT-1065A
2.00	3.150 (80)	8	3	.591 (15)	8	2.756 (70)	1.575 (40)	145	(66)	PNBT-1080A
2.50	3.740 (95)	10	4	.591 (15)	8	3.346 (85)	2.165 (55)	162	(74)	PNBT-1095A
3.00	4.921 (125)	14	6	.591 (15)	8	4.528 (115)	3.346 (85)	198	(90)	PNBT-1125A
1.00	1.969 (50)	4	1	.591 (15)	4	1.575 (40)	—	96	(44)	PNBT-2050A
1.50	2.559 (65)	6	2	.591 (15)	4	2.165 (55)	—	114	(52)	PNBT-2065A
2.00	3.150 (80)	8	3	.591 (15)	8	2.756 (70)	1.575 (40)	145	(66)	PNBT-2080A
2.50	3.740 (95)	10	4	.591 (15)	8	3.346 (85)	2.165 (55)	162	(74)	PNBT-2095A
3.00	4.921 (125)	14	6	.591 (15)	8	4.528 (115)	3.346 (85)	198	(90)	PNBT-2125A
1.00	2.165 (55)	2	—	—	4	1.378 (35)	—	193	(88)	PNBT-3055A
2.00	4.134 (105)	6	2	.984 (25)	4	3.346 (85)	—	338	(154)	PNBT-3105A
3.00	6.102 (155)	10	4	.984 (25)	6	5.315 (135)	—	477	(217)	PNBT-3155A
2.00	3.346 (85)	2	—	—	4	2.559 (65)	—	430	(196)	PNBT-4085A
3.00	4.921 (125)	4	2	1.575 (40)	4	4.134 (105)	—	600	(273)	PNBT-4125A
4.00	6.496 (165)	6	4	1.575 (40)	6	5.709 (145)	—	723	(329)	PNBT-4165A

## Profile and Mounting Dimensions

A ± .005 (0.13)	B ± .010 (25)	C	Carriage				Base Spacing				Series
			Spacing		Thread Depth		R	S	Counterbore		
			N	P	J	K			D	d	
.590 (15)	1.181 (30)	.160 (4.1)	.689 (17.5)	.394 (10)	4-40	.177 (4.5)	.197 (5)	.866 (22)	.198 (5)	.125 (3.1)	PNBT-1000A
.827 (21)	1.575 (40)	.256 (6.5)	.689 (17.5)	.591 (15)	6-32	.315 (8)	.197 (5)	1.181 (30)	.241 (6.1)	.144 (3.7)	PNBT-2000A
1.102 (28)	2.362 (60)	.354 (9)	1.083 (27.5)	.984 (25)	10-32	.413 (10.5)	.394 (10)	1.575 (40)	.328 (8.3)	.197 (5)	PNBT-3000A
1.378 (35)	3.150 (80)	.413 (10.5)	1.673 (42.5)	1.575 (40)	10-32	.512 (13)	.394 (10)	2.165 (55)	.328 (8.3)	.197 (5)	PNBT-4000A

Measurement in inches

# STEEL CROSSED ROLLER SLIDES

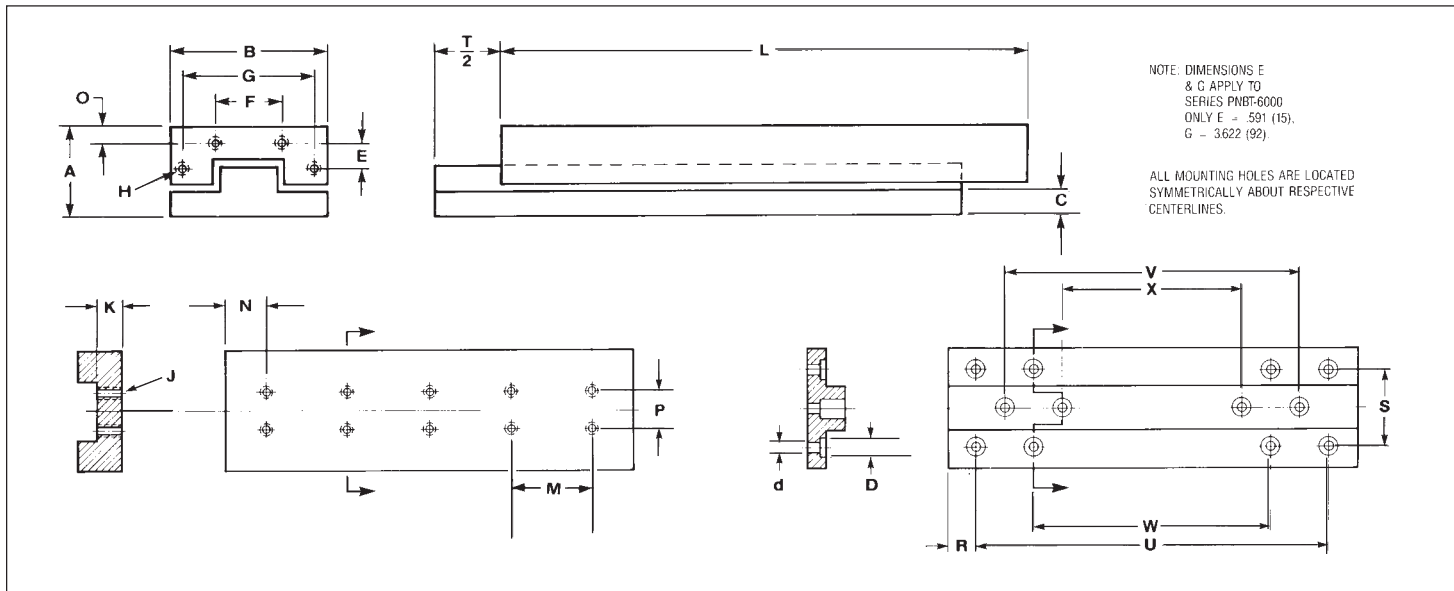

## Specifications

**Straight line accuracy:** .00008" for 1.0" — 4.0" of length .00012" for 4.1" — 12.5" of length

**Material:** Steel Base and Carriage

**Finish:** Black Oxide finish

## Travel Length and Load Selection

Dimension in Inches (mm)		Carriage Mounting Holes (Threaded)			Base Mounting Holes (Counterbored)				Load Capacity		Part No.
Length L	Travel T	No. Holes	No. Spaces	Spacing M	No. Holes	Spacing U	Spacing W	Spacing V	LBF	(Kgf)	
.984 (25)	.472 (12)	2	—	—	4	.709 (18)	1.102 (28)		26	(12)	PNBT-1025
1.378 (35)	.709 (18)	4	1	.394 (10)	4	1.108 (28)			35	(18)	PNBT-1035
1.772 (45)	.984 (25)	6	2	.394 (10)	4	1.496 (38)			44	(20)	PNBT-1045
2.165 (55)	1.260 (32)	8	3	.394 (10)	8	1.890 (48)			57	(26)	PNBT-1055
1.378 (35)	.709 (18)	2	—	—	4	.984 (25)			88.0	(40)	PNBT-2035
1.969 (50)	1.181 (30)	4	1	.591 (15)	4	1.575 (40)			138.0	(63)	PNBT-2050
2.559 (65)	1.575 (40)	6	2	.591 (15)	4	2.165 (55)			165.0	(75)	PNBT-2065
3.150 (80)	1.969 (50)	8	3	.591 (15)	8	2.756 (95)			209.0	(95)	PNBT-2080
2.165 (55)	1.181 (30)	2	—	—	4	1.378 (55)			277.0	(126)	PNBT-3055
3.150 (80)	1.772 (45)	4	1	.984 (25)	4	2.362 (60)			405.0	(184)	PNBT-3080
4.134 (105)	2.362 (60)	6	2	.984 (25)	4	3.345 (85)	484.0	(220)	PNBT-3105		
5.118 (130)	2.953 (75)	8	3	.984 (25)	4	4.331 (110)	605.0	(275)	PNBT-3130		
6.102 (155)	3.543 (90)	10	4	.984 (25)	6	5.315 (135)	882.0	(310)	PNBT-3155		
3.346 (85)	1.969 (50)	2	—	—	4	2.559 (65)	616.0	(280)	PNBT-4085		
4.921 (125)	2.953 (75)	4	1	1.575 (40)	4	4.134 (105)	858.0	(390)	PNBT-4125		
6.496 (165)	4.134 (105)	6	2	1.575 (40)	4	5.709 (145)	1034.0	(470)	PNBT-4165		
4.331 (110)	2.362 (60)	2	—	—	4	3.543 (90)	880.0	(400)	PNBT-6110		
6.300 (160)	3.740 (95)	4	1	1.969 (50)	4	5.512 (140)	1518.0	(690)	PNBT-6160		
8.268 (210)	5.118 (130)	6	2	1.969 (50)	6	7.480 (190)	1914.0	(870)	PNBT-6210		
12.20 (310)	7.874 (200)	10	4	1.969 (50)	6	11.420 (290)	2640.0	(1200)	PNBT-6310		

Measurement in inches

## Profile and Mounting Dimensions

A ± .004	B ± .004	C	N	P	J	K	Dust Cover Attachment			R	S	D	d	Series
							O	F	Thread H					
.669 (17)	1.181 (30)	.217 (5.5)	.492 (12.5)	.394 (10)	M2	.275 (7)	.098 (2.5)	.472 (12)	M2	.138 (3.5)	.866 (22)	.185 (4.7)	.106 (2.7)	PNBT-1000
.827 (21)	1.575 (40)	.256 (6.5)	.689 (17.5)	.591 (15)	M3	.315 (8)	.134 (3.4)	.630 (16)	M2	.197 (5)	1.181 (30)	.252 (6.4)	.153 (3.9)	PNBT-2000
1.102 (28)	2.362 (60)	.354 (9)	1.083 (27.5)	.984 (25)	M4	.413 (10.5)	.217 (5.5)	1.575 (40)	M3	.394 (10)	1.575 (40)	.315 (8)	.197 (5)	PNBT-3000
1.378 (35)	3.150 (80)	.413 (10.5)	1.673 (42.5)	1.575 (40)	M5	.512 (13)	.256 (6.5)	2.165 (55)	M3	.394 (10)	2.165 (55)	.374 (9.5)	.220 (5.6)	PNBT-4000
1.772 (45)	3.937 (100)	.512 (13)	2.165 (55)	1.969 (50)	M6	.630 (16)	.315 (8)	2.362 (60)	M4	.394 (10)	2.362 (60)	.433 (11)	.283 (7.2)	PNBT-6000

# ECONOMY CROSSED ROLLER SLIDES

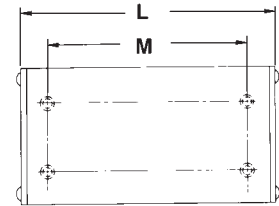
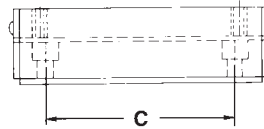
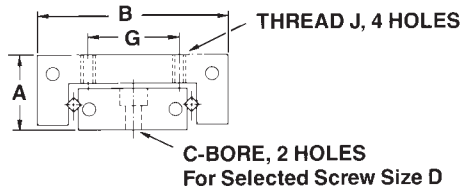

All mounting holes are located symmetrically about respective centerlines.

## Specifications

Straight line accuracy: .0001"/inch of travel  
 Repeatability: .0001"

Material: Aluminum Base and Carriage  
 Finish: Black Anodize

Total Travel*	L	M	C	A	B	G	J	D	Load Capacity (lbs.)	Part No.
50	1.06	.625	.750	.32	.56	.218	2-56	2-56	30	PRB05-05
1.00	2.06	1.625	1.375	.32	.56	.218	2-56	2-56	55	PRB05-10
2.00	3.06	2.625	2.375	.32	.56	.218	2-56	2-56	66	PRB05-20
50	1.06	.625	.750	.40	.75	.375	4-40	4-40	48	PRB08-05
1.00	2.06	1.625	1.375	.40	.75	.375	4-40	4-40	78	PRB08-10
2.00	3.06	2.625	2.375	.40	.75	.375	4-40	4-40	94	PRB08-20
1.50	2.56	2.250	2.125	.53	1.06	.437	6-32	6-32	132	PRB12-15
2.00	3.56	3.250	3.125	.53	1.06	.437	6-32	6-32	220	PRB12-20
3.00	4.56	4.000	3.250	.53	1.06	.437	6-32	6-32	264	PRB12-30
1.00	2.00	1.375	1.500	.62	1.50	.625	6-32	6-32	132	PRB15-10
2.00	3.00	2.375	2.500	.62	1.50	.625	6-32	6-32	176	PRB15-20
3.00	4.00	3.375	3.500	.62	1.50	.625	6-32	6-32	176	PRB15-30
4.00	6.00	5.375	4.000	.62	1.50	.625	6-32	6-32	308	PRB15-40
1.00	2.00	1.375	1.625	.75	1.75	.875	6-32	6-32	132	PRB2-10
2.00	3.25	2.625	2.750	.75	1.75	.875	6-32	6-32	176	PRB2-20
3.00	4.00	3.375	3.500	.75	1.75	.875	6-32	6-32	176	PRB2-30
4.00	6.00	5.500	4.000	.75	1.75	.875	6-32	6-32	308	PRB2-40
1.50	2.62	1.625	1.875	1.00	2.62	1.250	10-32	10-32	264	PRB3-15
2.00	4.00	3.000	3.375	1.00	2.62	1.250	10-32	10-32	352	PRB3-20
3.00	5.00	4.000	4.375	1.00	2.62	1.250	10-32	10-32	440	PRB3-30
4.00	6.00	5.000	5.375	1.00	2.62	1.250	10-32	10-32	440	PRB3-40

\*Minimum centered around mean position. Typical overtravel 0.06" each direction.

## RAILS

### Application

Bearings are normally supplied and installed in sets of two to form an assembly that can support their rated load in any direction or orientation, and can be preloaded to eliminate side play.

Mounting and banking surfaces must be smooth and flat, and accurately parallel, coplanar, or perpendicular respectively to achieve maximum accuracy. Preload forces must be evenly distributed. Dirt and dust must be excluded. Lubrication required depends on the application, ranging from light grease or oil at the time of installation for low speeds (less than 50 inches/min.) and occasional movement to continuous oil bath or mist at 1200 inches/min.

### Construction

Each bearing consists of a pair of hardened steel ways containing 90° vee grooves, and a row of alternately crossed cylindrical rollers. The hardened steel rollers are captive in a cage for easy handling and assembly and permanent alignment. The ways are installed face to face by the user, with the rollers between the vee grooves.

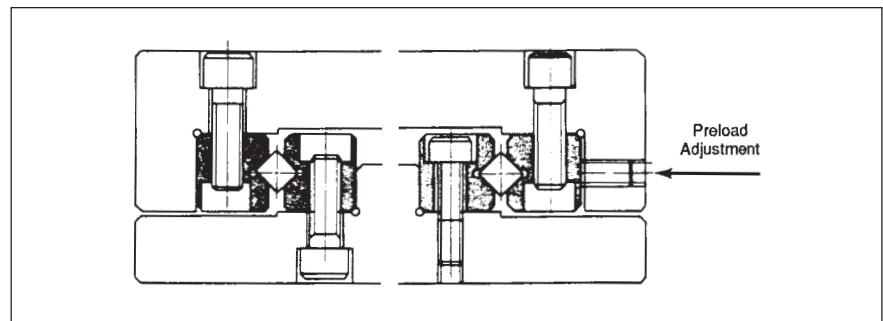

Mounting holes in the way bars are threaded, and also counter-bored to alternatively permit using the next smaller size threaded mounting holes in the user's components.



# RAILS

Sold & Serviced By:



Toll Free Phone (877) SERV098  
 Toll Free Fax (877) SERV099  
[www.electromate.com](http://www.electromate.com)  
[sales@electromate.com](mailto:sales@electromate.com)

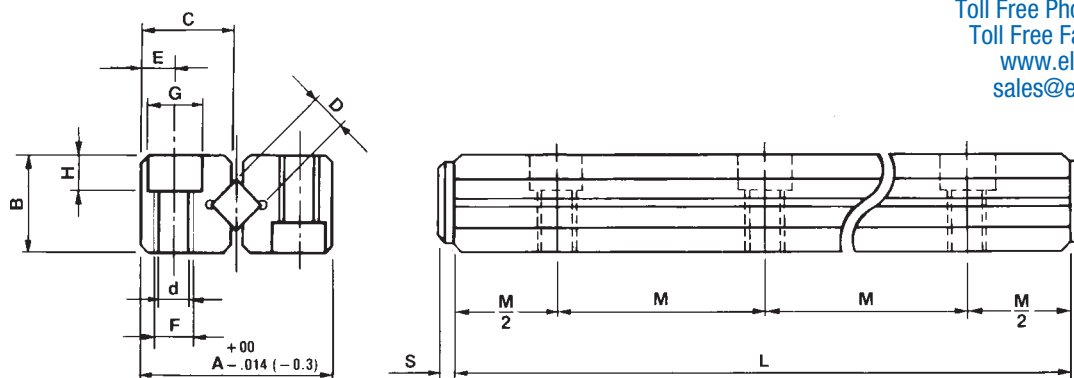

### Specifications

Maximum deviation from parallelism between vee groove face and datum face for each way bar is 200 micro inches.

Rails: Hardened Steel

Rollers: Hardened Steel

**NOTE:** Each set contains 4-V grooved rails with end screws and 2-roller cages with captive rollers.

### Length, Travel, and Load Selection

Travel T	Length L	No. Rollers in Each Retainer	No. Holes	Rail Set Load Cap. (lbs.)	Part No.
.473 (12)	.788 (20)	5	2	44	PNB1-020
.788 (20)	1.181 (30)	7	3	61	PNB1-030
1.063 (27)	1.575 (40)	10	4	88	PNB1-040
1.260 (32)	1.969 (50)	13	5	114	PNB1-050
.709 (18)	1.181 (30)	5	2	66	PNB2-030
.945 (24)	1.772 (45)	8	3	105	PNB2-045
1.181 (30)	2.362 (60)	11	4	145	PNB2-060
1.732 (44)	2.953 (75)	13	5	171	PNB2-075
1.102 (28)	1.969 (50)	7	2	154	PNB3-050
1.890 (48)	2.953 (75)	10	3	220	PNB3-075
2.283 (58)	3.937 (100)	14	4	308	PNB3-100
3.071 (78)	4.921 (125)	17	5	374	PNB3-125
3.464 (88)	5.906 (150)	21	6	462	PNB3-150
2.283 (58)	3.150 (80)	7	2	308	PNB4-080
3.228 (82)	4.725 (120)	11	3	484	PNB4-120
4.134 (105)	6.299 (160)	15	4	660	PNB4-160
2.165 (55)	3.937 (100)	8	2	704	PNB6-100
3.346 (85)	5.906 (150)	12	3	1056	PNB6-150
4.724 (120)	7.874 (200)	16	4	1408	PNB6-200
7.283 (185)	11.811 (300)	24	6	2112	PNB6-300
9.646 (245)	15.748 (400)	32	8	2816	PNB6-400

### Profile and Mounting Dimensions

A	B	C	D	S	M	E	F	J	d	G	H	Series
.335 (8.5)	.158 (4.0)	.154 (3.9)	.059 (1.5)	.059 (1.5)	.394 (10)	.071 (1.8)	M2	# 0	.065 (1.65)	.118 (3.0)	.055 (1.4)	PNB1-000
.473 (12)	.236 (6.0)	.217 (5.5)	.079 (2.0)	.079 (2.0)	.591 (15)	.098 (2.5)	M3	# 2	.100 (2.55)	.173 (4.4)	.079 (2.0)	PNB2-000
.708 (18)	.315 (8.0)	.327 (8.3)	.118 (3.0)	.079 (2.0)	.984 (25)	.138 (3.5)	M4	# 4	.130 (3.30)	.236 (6.0)	.122 (3.1)	PNB3-000
.866 (22)	.433 (11)	.402 (10.2)	.158 (4.0)	.079 (2.0)	1.575 (40)	.178 (4.5)	M5	# 8	.169 (4.3)	.315 (8.0)	.165 (4.2)	PNB4-000
1.221 (31)	.591 (15)	.559 (14.2)	.236 (6.0)	.118 (3.0)	1.969 (50)	.236 (6.0)	M6	#10	.205 (5.2)	.374 (9.5)	.205 (5.2)	PNB6-000

Measurement in inches (mm)

# BALL SLIDE GUIDES

## Compact Design

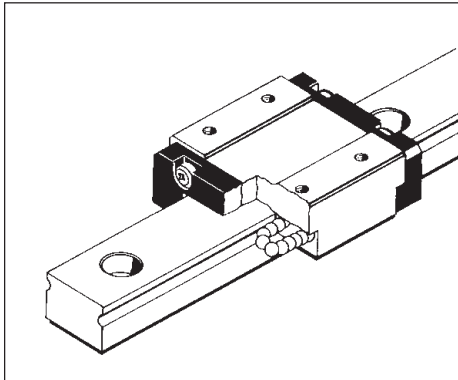

### SEB (Ball type) — Low Price / High Speed

The SEB type slide guide consists of a block and a guide rail, both of which have two precision-ground, R-shaped raceway grooves. Steel balls recirculate in each raceway groove while they make 4 point contact. The block consists of a main body with raceway grooves and a pair of resin return caps for smooth circulation of steel balls.

- Smooth and stable operation.
- Compact, lightweight and low price.
- High load capacity by the use of Gothic arch grooves.
- Four-point contact to carry load and moment in all directions.
- Dust protection wiper as standard.
- Extra wide type also available.
- For higher accuracy and rigidity, a crossed roller version is available.
- All stainless steel version available — consult factory

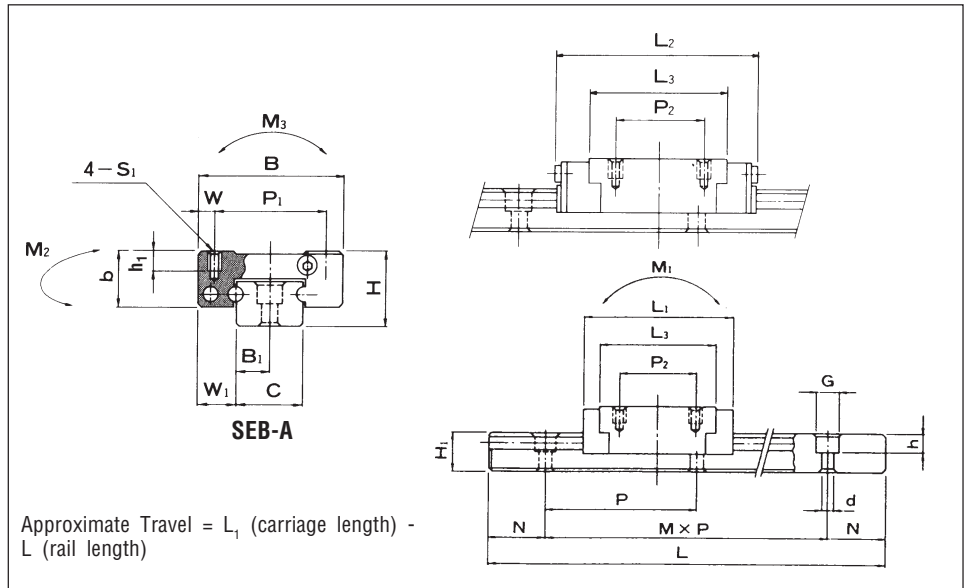

Approximate Travel =  $L_1$  (carriage length) -  $L$  (rail length)

### Ordering Information

Order standard ball slide guides from table by model number. Include the number of slide units required on one rail and the guides rail length in mm.

**EXAMPLE: SEB12 U — 1 — 370**

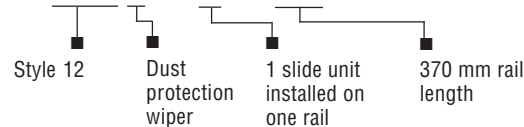

Sold & Serviced By:



Toll Free Phone (877) SERV098  
Toll Free Fax (877) SERV099  
www.electromate.com  
sales@electromate.com

Style	Dimensions Of Carriage											Basic Load Rating		Dimensions Of Guide Rail (Metric)						
	H	B	Wiper L <sub>2</sub>	L <sub>1</sub>	W	P <sub>1</sub>	P <sub>2</sub>	S <sub>1</sub>	h <sub>1</sub>	L <sub>3</sub>	b	C lbf (CN)	Co lbf (CON)	H <sub>1</sub>	C	B <sub>1</sub>	W <sub>1</sub>	d x G x h	N	
SEB 2U**	.126 (3.2)	.236 (6)	.563 (14.3)	.508 (12.9)		—	.157 (4)	M1.4	—	.366 (9.3)	.098 (2.5)	47 (210)	85 (380)	.079 (2)	.079 (2)	—	—	—	(4)	
SEB 3U**	.157 (4)	.315 (8)	.465 (11.8)	.413 (10.5)		—	.138 (3.5)	M1.6	—	.256 (6.5)	.118 (3)	56 (250)	81 (360)	.102 (2.6)	.118 (3)	—	—	—	(5)	
SEB 5U***	.236 (6)	.472 (12)	.669 (17)	.614 (15.6)	.079 (2)	.315 (8)	—	M2	.059 (1.5)	.386 (9.8)	.177 (4.5)	96 (430)	160 (715)	.157 (4)	.197 (5)	.098 (2.5)	.138 (3.5)	.094 x .138 x .039 (2.4 x 3.5 x 1)	.197 (5)	
SEB 7U***	.315 (8)	.669 (17)	.925 (23.5)	.862 (21.9)	.098 (2.5)	.472 (12)	.318 (8)	M2	.098 (2.5)	.594 (15.1)	.256 (6.5)	242 (1080)	375 (1670)	.185 (4.7)	.276 (7)	.138 (3.5)	.197 (5)	.094 x .165 x .091 (2.4 x 4.2 x 2.3)	.197 (5)	
SEB 9U	.394 (10)	.787 (20)	1.20 (30.5)	1.106 (28.1)	.098 (2.5)	.591 (15)	.394 (10)	M3	.118 (3)	.803 (20.4)	.307 (7.8)	375 (1670)	551 (2450)	.217 (5.5)	.354 (9)	.177 (4.5)	.217 (5.5)	.138 x .236 x .138 (3.5 x 6 x 3.5)	.295 (7.5)	
SEB 12U	.512 (13)	1.063 (27)	1.339 (34)	1.181 (30)	.138 (3.5)	.787 (20)	.591 (15)	M3	.138 (3.5)	.906 (23)	.394 (10)	485 (2160)	706 (3140)	.295 (7.5)	.472 (12)	.236 (6)	.295 (7.5)	.138 x .236 x .177 (3.5 x 6 x 4.5)	.394 (10)	
SEB 15U	.630 (16)	1.260 (32)	1.673 (42.5)	1.516 (38.5)	.138 (3.5)	.984 (25)	.788 (20)	M3	.157 (4)	1.161 (29.5)	.472 (12)	816 (3630)	1212 (5390)	.374 (9.5)	.591 (15)	.295 (7.5)	.335 (8.5)	.138 x .236 x .177 (3.5 x 6 x 4.5)	.591 (15)	
SEB 20U	.984 (25)	1.811 (46)	2.441 (62)	2.193 (55.7)	.157 (4)	1.496 (38)	1.496 (38)	M4	.236 (6)	1.709 (45.7)	.689 (17.5)	1542 (6860)	2203 (9800)	.591 (15)	.787 (20)	.394 (10)	.512 (13)	.236 x .374 x .335 (6 x 9.5 x 8.5)	.788 (20)	

Measurements in inches (mm)

This table is continued...

Note: Inch conversion to mm: 25.4 x Inch

\* Rail is tapped for SEB2 & SEB3 Series. SEB2 - M1 / SEB3 - M1.6

\*\* Rail Mounting screws supplied with rails for SEB5 - M2 x .4 x 6 Phillips head

• Stainless Steel

# SLIDE GUIDES

Continued From Preceding Page

Sold & Serviced By:



Toll Free Phone (877) SERV098  
 Toll Free Fax (877) SERV099  
 www.electromate.com  
 sales@electromate.com

**Specifications:**

Accuracy (See Figure 1):

	Inches	(mm)
Height H tolerance	0.0008	(0.020)
Height H pair variation	0.0006	(0.015)
Width $W_1$ tolerance	0.001	(0.025)
Width $W_1$ pair variation	0.0008	(0.020)

**Temperature:**

Ambient temperatures up to 100°C (212°F) maximum.

**Running Parallelism:**

Surface C to Surface A See Figure 2  
 Surface D to Surface B See Figure 2

**Load Ratings:**

In applications involving high impact or speeds in excess of 2400"/min., divide the rated load rating by a factor of 3.

**Preload:**

Factory set preload ensures high rigidity.

**Materials:**

Roller rails and slide-block are made of 52100 chrome steel

- Stainless Steel (SEB 2,3,5&7)

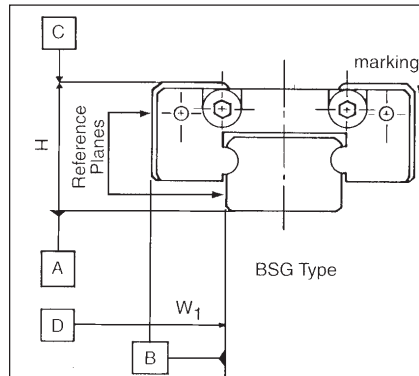

Figure 1.

Figure 2.

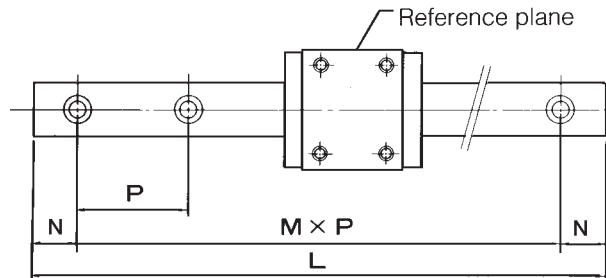
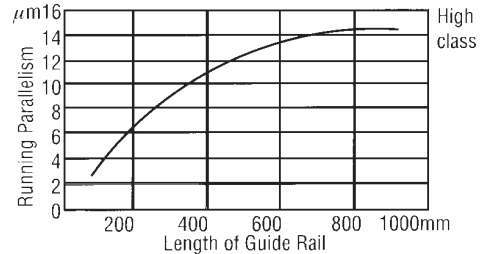

Figure 3. Special length guide rails

**Special-Length Guide Rails**

For the SEB and SER types, special-length guide rails are also available, within the maximum length of the standard product. If the n1 and n2 dimensions shown in Figure 3 are not specified, such rails are manufactured within the standard dimension range.

**Lubrication and Dust Prevention**

The slide guides are shipped lubricated with sealed quality lithium soap base lubricant and can be used directly. The guides are standard with a wiper to prevent contamination.

Guide Rail Lengths (Metric)											Allowable Static Moments			Weight (Metric)		Style		
Length			Length			Length			Length			P	M <sub>1</sub> LB-IN	M <sub>2</sub> LB-IN	M <sub>3</sub> LB-IN		Carriage lb(kg)	Guide Rail lb/ft(kg/m)
L <sub>in.</sub>	(L <sub>mm</sub> )	[M]	L <sub>in.</sub>	(L <sub>mm</sub> )	[M]	L <sub>in.</sub>	(L <sub>mm</sub> )	[M]	L <sub>in.</sub>	(L <sub>mm</sub> )	[M]							
1.260 4.094	(32) (104)	[3] [12]	1.575 (40)	[4]	2.205 (56)	[6]	3.150 (80)	[9]	(8)	4.6	5.6	3.6	.002 (.0008)	.018 (.028)	SEB 2U**			
1.181 3.937	(30) (100)	[2] [9]	1.575 (40)	[3]	2.362 (60)	[5]	3.150 (80)	[7]	(10)	3.4	4	5	.002 (.001)	.033 (.05)	SEB 3U**			
1.575 5.118	(40) (130)	[2] [8]	2.165 6.299	(55) (160)	[3] [10]	2.756 (70)	[4]	3.937 (100)	[6]	.591 (15)	11	13	18	.006 (.003)	.087 (.13)	SEB 5U***		
1.575 3.937	(40) (100)	[2] [6]	2.165 5.118	(55) (130)	[3] [8]	2.756 (70)	[4]	3.346 (85)	[5]	.591 (15)	27	32	46	.022 (0.01)	.128 (0.19)	SEB 7U***		
2.165 6.102	(55) (155)	[2] [7]	2.953 7.677	(75) (195)	[3] [9]	3.740 10.827	(95) (275)	[4] [13]	4.528 (115)	[5]	.788 (20)	67	80	101	.044 (0.02)	.208 (0.31)	SEB 9U	
4.724 12.598	(120) (320)	[4] [12]	6.693 14.567	(170) (370)	[6] [14]	8.661 18.504	(220) (470)	[8] [18]	10.630 (270)	[10]	.984 (25)	92	109	177	.088 (0.04)	.410 (0.61)	SEB 12U	
5.906 21.652	(150) (550)	[3] [13]	9.055 26.378	(230) (670)	[5] [16]	12.205 (310)	[7]	16.929 (430)	[10]	1.575 (40)	191	225	356	.132 (0.06)	.685 (1.02)	SEB 15U		
8.661 25.197	(220) (640)	[3] [10]	11.024 34.646	(280) (880)	[4] [14]	13.386 (340)	[5]	18.110 (460)	[7]	2.362 (60)	451	538	868	.507 (0.23)	1.438 (2.14)	SEB 20U		

... on this page.

# X-XY-XYZ POSITIONERS WITH MICROMETERS

## Profile Dimensions

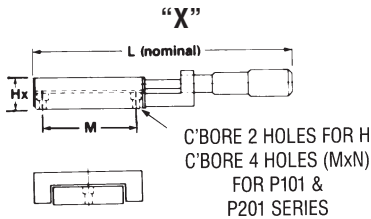

## "X - Y"

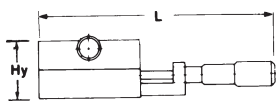

## "X - Y - Z"

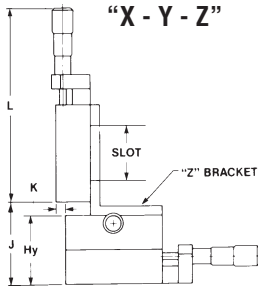

## Carriage Mounting Dimensions

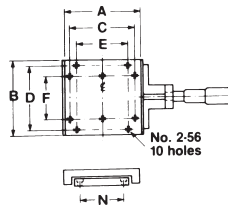

Series	C	D	E	F	N
101	1.00	1.00	.69	.50	.69
201	1.50	1.50	1.19	1.00	1.19

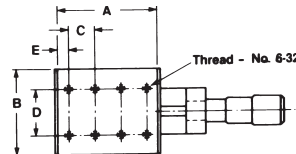

Series	C	D	E	No. Holes
400	.50	.875	.25	8
500	.55	.875	.25	12

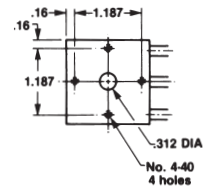

Series 300

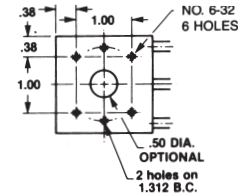

Series 450

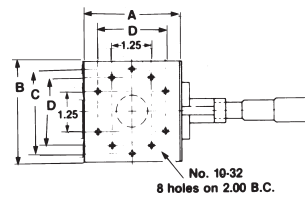

Series	C	D
1200	2.625	2.125
2200	3.625	3.125

## Optional Carriage Positional Lock

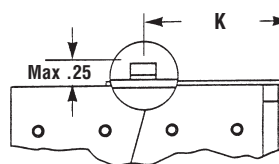

See Note 3 Below

Series	K Nominal
P100	1.265
P200	
P1200	1.750
P2200	2.250
P400	2.390
P300	2.395
P450	
P500	

Sold & Serviced By:



Toll Free Phone (877) SERV098  
Toll Free Fax (877) SERV099  
www.electromate.com  
sales@electromate.com

## Specifications

**Straight line accuracy:** .0005/inch of travel

**Repeatability:** .0001

**Drive:** Micrometer .001 graduations standard  
.01 mm graduations optional

**Material:** Aluminum Base and Carriage

**Finish:** Black Anodize

Travel T	A	B	L	Base Mounting M	H	Hx	Hy	J	K	Load Capacity (lbs.)		Part No.*
										X, XY	Z	
.50	1.25	1.25	3.25	1.00	# 2	.38	.75	.62	.38	4	1.25	P101- P201- P301- P401-
.50	1.75	1.75	3.75	1.50	# 2	.38	.75	.62	.44	4	1.25	
.50	1.50	1.50	3.50	1.187	# 4	.62	1.25	1.62	.32	12	2	
.50 (13mm)	2.00	1.75	4.62	1.62	# 6	.75	1.69	.50	1.12	20	2	
.50 (13mm)	1.75	1.75	4.38	1.312	# 6	.75	1.50	2.00	Flush	20	2	P450- P451- P501- P502- P1201- P2201-
1.00 (25mm)	1.75	1.75	5.88	1.312	# 6	.75	1.50	2.00	Flush	20	2	
.50 (13mm)	3.25	1.75	5.86	2.75	# 6	.75	1.69	1.56	Flush	42	20	
1.00 (25mm)	3.25	1.75	7.41	2.75	# 6	.75	1.69	1.56	Flush	42	20	
1.00 (25mm)	3.12	3.12	7.25	2.625	#10	.88	1.76	2.50	.50	30	30	
1.00 (25mm)	4.12	4.12	8.38	3.625	#10	.88	1.76	2.75	.56	30	30	
.50	1.50	1.50	3.50	1.187	# 4	.62	1.25	.44	1.00	—	2	P301LP.** P450LP.** P451LP.**
.50 (13mm)	1.75	1.75	4.38	1.312	# 6	.75	1.50	.69	1.12	—	2	
1.00 (25mm)	1.75	1.75	5.88	1.312	# 6	.75	1.50	.69	1.12	—	2	

\* To order any positioner, please follow these directions with the appropriate series.

1. Add "M" for Metric Micrometer.  
2. Designate axis desired as follows:  
X, XY, or XYZ  
Example: P101-X  
P101-XYZ  
P401-XY  
P401M-XY

3. For optional lock substitute L for dash  
(-) in part number  
Example: P101LX

\*\* LP indicates low profile for XYZ only.