

CLUTCHES, BRAKES & COUPLINGS

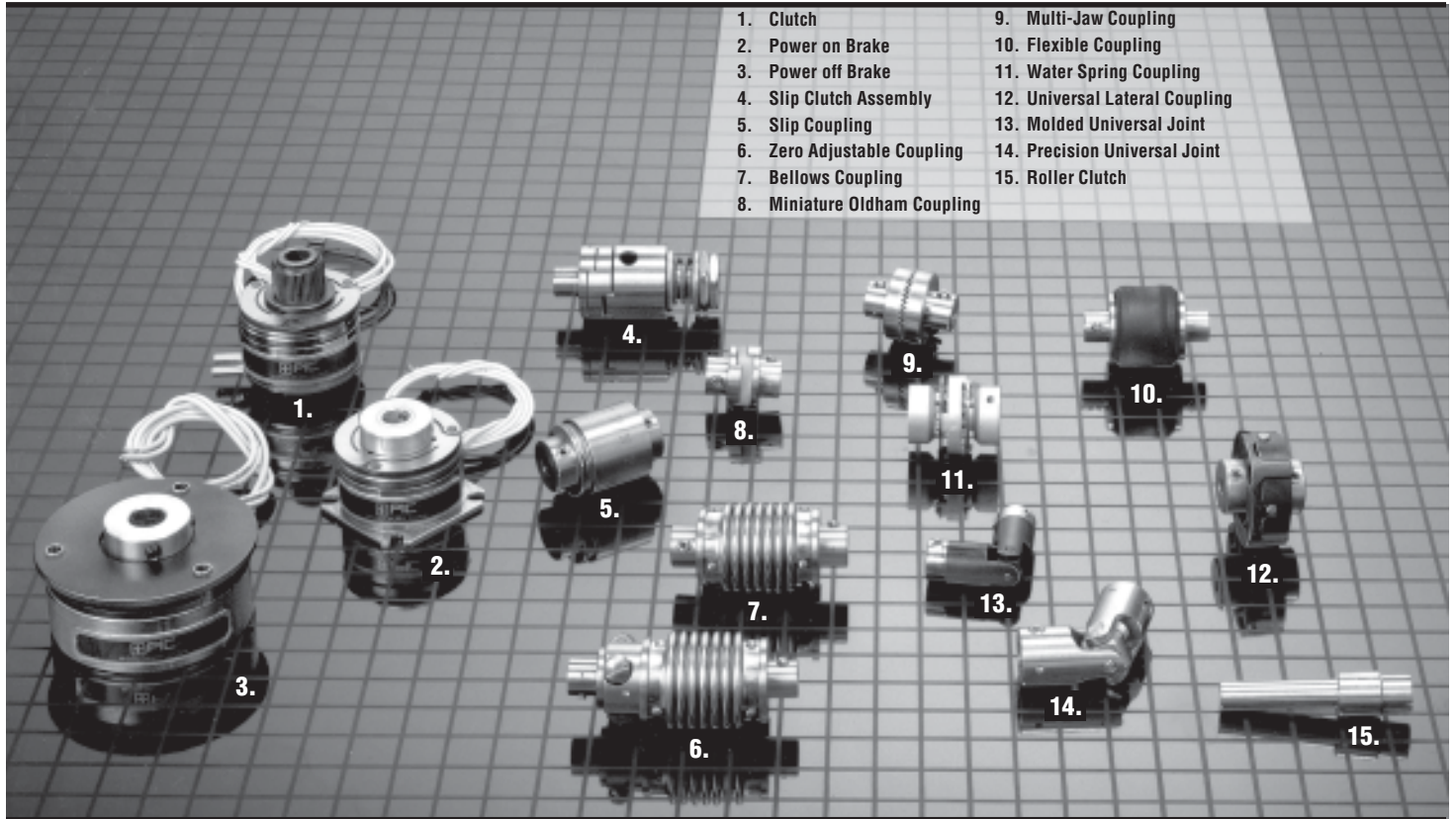

Whatever type of clutch, brake or coupling your application requires, you can be most assured of finding it quickly and easily among the comprehensive assortment of such components available from PIC Design...one that includes a complete selection of electro-magnetic clutches and brakes and mechanical slip clutches and couplings.

PIC Design Clutches, Brakes and Couplings— A Brief Overview

ELECTRIC CLUTCHES AND BRAKES

The PIC line comprises both shaft-mounted clutches and flange-mounted power-on and power-off brakes, all highly suited to situations in which an immediate response is required in either start or stop functions of driving mechanisms. The variety of voltages and bore sizes offered is aimed at giving designers and engineers especially easy access to precise components needed for such applications as copier drives, tape and film drives and packaging machines.

SERVO ELECTRIC CLUTCHES AND BRAKES

These units consist of miniature precision electro-magnetic clutches and brakes designed for use in

military/aerospace applications and precision servo mechanisms. Each is available with a servo mounting flange and with one or two output shafts.

SLIP CLUTCHES

These stainless steel mechanical clutches come precision-calibrated and spring-wrapped, and are designed to accommodate the mounting of input gears, sprockets or pulleys. Slip torque is stable and independent of velocity, regardless of rotational direction.

ROLLER CLUTCHES

The roller clutches are used to transmit torque between the shaft and housing in one direction and allows free overrun in the opposite direction. The clutches are generally used in applications requiring indexing, backstopping, or overrunning.

SLIP COUPLINGS

These devices not only serve as couplings for two colinear shafts, but also as a torque limiter. When the load exceeds the limit torque of a slip coupling, the two shafts will rotate relative to each other at the full limit torque.

COUPLINGS

The designs and styles listed below are suitable for a wide array of applications; for example, a design requiring the connection of two in-line shafts of equal or unequal diameters measured either in inches or millimeters.

- Bellows Couplings
- Zero Adjustable Couplings
- Flexible Couplings
- Miniature Oldham Couplings
- Wafer Oldham Couplings
- Universal Lateral Couplings
- Multi-Jaw Couplings
- Precision Universal Joint Couplings
- Molded Universal Joint Couplings
- Precision Sleeve Couplings
- Flexible Zero Backlash Couplings
- Spider Coupling

Assistance in determining which coupling best fills your particular requirements is provided in the technical section that follows.

TECHNICAL SECTION

Industrial Clutches and Brakes

Clutches in this category are utilized in applications involving a driving shaft which, when rotating, is able to engage or disengage a secondary shaft driven either by gears or a belt-and-pulley combination. Industrial brakes are intended for applications in which the primary mover is to be held at its stop position. A power-on brake will decelerate and provide inertia when power is supplied, requiring that power be transferred from motor to brake. A power-off brake is energized along with the motor itself, decelerating and retaining inertia when the power is shut off. The latter is geared to applications where power consumption and safety are of major concern.

PIC Design clutches and brakes can perform any of the following functions for a variety of applications similar to the ones listed below:

Functions	Applications
Remote Coupling	Copier Paper Drives
Instant Reversing	Computer Disc Drives
Speed Changing	Card Feeders
Torque Limiting	Collators
Rapid Cycling	Money Dispensers
Indexing	Teletype Machines
Jogging	X-Ray Table Drives
Tensioning	Blood Gas Analyzers
Cushioned Starts & Stops	Ticket Dispensers

BURNISHING

Burnishing is a wearing in or mating process used to ensure the highest possible output torques. It is accomplished by forcing the clutch or brake to slip rotationally when energized. Best results are obtained when the unit is energized at 30-40% of rated voltage and forced to slip for a period of 2-3 minutes at a low speed of 100-200 rpm. Units in applications involving high inertial loads and speed will usually become burnished in their normal operating mode. Whenever possible, it is desirable to perform the burnishing operation in the final location so the alignment of the burnished faces will not be disturbed.

CYCLE LIFE EXPECTANCY

The number of cycles a clutch or brake will produce before it ceases to function is largely dependent on the following factors: (1) duration of slip while accelerating or decelerating a given load, (2) ability of individual unit to dissipate heat generated at friction faces, (3) thickness of friction material (used to retard wear), (4) thickness of armature plate, (5) type of bearing system used in clutch, (6) environmental conditions contributing to bearing and friction face degradation (dust, lint, grit, toner, oil, etc.). Units that are required to accelerate or stop small inertial loads at low shaft speeds (under 500 rpm) will experience little slip before lock-in at time of engagement, hence minimal wear and extremely long life, commonly in the tens of millions of cycles (typical of copy machine applications). The bearing system is usually the life limiting factor in these applications. Units that are required to accelerate or stop loads with large inertia (such as punch press fly wheels) will experience a longer duration of slip before lock-in, resulting in faster wear and the shortened life. Friction face wear only occurs while the units are slipping differentially.

Couplings

COUPLING SELECTION GUIDE

Coupling Type	Angular Misalignment > 5°	Angular Misalignment < 5°	Lateral Misalignment > .010"	Withstand Shock Loads	Vibration Dampening	High Speeds	High Torque	High Ambient Temperature	Clean Room Environment	Stepper Motors	Reversing Drives	Maintenance Required	Vacuum Environment (No Lube)	Compressibility	Electrically Insulated
Bellows	X	X						X	X	X	X	X	X		
Zero Adjustable	X	X						X	X	X	X	X	X		
Flexible	X	X	X	X	X			X						X	
Oldham	X	X				X					X	X			
Wafer Spring	X	X	X	X	X	X	X	X	X	X	X	X	X		
Universal Lateral	X	X	X	X	X			X	X	X					X
Multi-Jaw			X				X	X	X		X	X			
Universal Joint	X	X					X	X		X	X	X			
Molded Universal Joint	X	X		X	X			X	X	X					X
Sleeve Coupling				X	X	X	X	X	X	X	X	X	X		
Flexible Zero Coupling		X	X		X	X	X	X	X	X	X	X	X	X	
Flexible K	X	X	X	X	X	X	X	X		X					X
Spider Coupling	X	X	X	X	X	X				X	X				X

Bellows Couplings

The ideal solution where shafts are angularly and laterally misaligned. They feature a stainless steel hub pinned to a stainless steel bellows.

Zero Adjustable Couplings

Get the same characteristics as on the bellows type coupling, except these couplings have an adjustable hub for zeroing synchros and other similar devices.

Flexible Couplings

These will isolate vibration, absorb shock loads and electrically insulate. They feature a molded neoprene body connected to stainless steel hubs.

Miniature Oldham Couplings

A choice of center block of oil impregnated bronze or nylon (eliminates metal-to-metal contact from taking place) between the hubs. Use these couplings in high-torque applications.

Wafer Spring Couplings

The choice for your highest torque applications and where there is up to 8° of angular and .03 inches of lateral misalignment.

Universal Lateral Couplings

Not only will these couplings provide electrical insulation, but they can handle up to 10° angular and .05 inches of lateral misalignment.

Multi-Jaw Couplings

Interlocking teeth permit precision coupling/decoupling with limited transmission error between two stainless steel hubs.

Universal Joint Couplings

Working angles up to 30° are no problem when you use these coupling. Standard in either Stainless Steel or Delrin.

Precision Sleeve Couplings

Use them when coupling shafts of similar or dissimilar diameters. This allows you to couple inch to inch, millimeter to millimeter, and inch to millimeter shafts.

Flexible Zero Backlash Couplings

Work well in high accuracy systems. Stainless steel or aluminum one-piece construction with high torsional stiffness, constant velocity, and very low wind up.

Flexible K Couplings

An excellent choice for use in abrasive dust environments and where maximum flexibility is required. The hubs are zinc plated; the bodies are polyurethane.

Spider Couplings

These provide high torque transmission without backlash or vibration due to the use of a chemically resistant and electrical isolating elastomer insert.

Shaft Extensions

Used to add an additional inch of shaft length or facilitate a change from special to standard shaft diameter. — See Section 6.

FLANGE MOUNTED-POWER OFF BRAKES

24 VDC and 120 VAC 3/16", 1/4", 5/16", and 3/8" Bores

Diagram 1

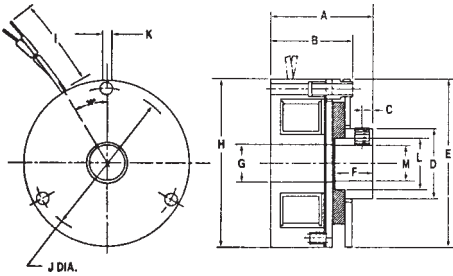
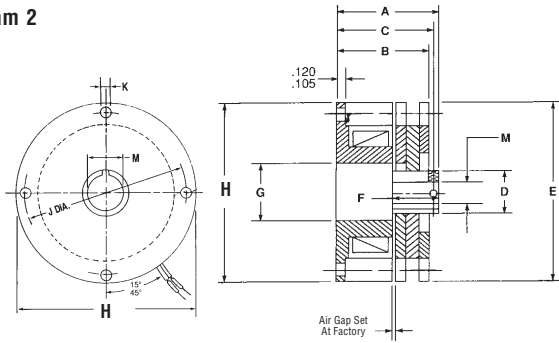

Diagram 2



PIC Series	A	B Max.	C Nom.	D Max.	E Max.	F Min.	G Ref.	H Max.	I ±.500	J Nom.	K Min.	L Nom.	Diagram
RY5	.890	.710	.072	.510	1.485	.320	.280	1.375	12.0	1.180	.113	3/8	1
RY6	1.060	.870	.115	.755	1.910	.380	.410	1.752	12.0	1.545	.113	9/16	1
RY7	1.400	1.200	1.255	.955	2.465	.450	.781	2.436	12.0	2.125	.170	5/8	2
RY8	1.400	1.200	1.255	.722	2.465	.605	.781	2.436	12.0	2.125	.170	5/8	2

PIC Series	24 VDC		120 VAC	
	Amps	Ohms	Amps	Ohms
RY5	.170	138	.041	N.A.
RY6	.190	132	.050	N.A.
RY7	.247	97.3	.045	N.A.
RY8	.369	65.1	.077	N.A.

Electrical

Key Way	M Nom.	Voltage	Part No.
3/64 x 3/32	5/16	120 VAC	RY7-704
	3/8	24 VDC	RY7-305
	3/8	120 VAC	RY7-705
1/32 x 1/16	5/16	24 VDC	RY8-304
	5/16	120 VAC	RY8-704
	3/8	24 VDC	RY8-305
3/64 x 3/32	3/8	120 VAC	RY8-705

Mechanical

Series	Typical Out-of-Box Torques lb.-in.	Rated Static Torques lb.-in.	Typical Torques After Burnishing lb.-in.
RY5	1	1	1.5
RY6	3	3	4
RY7	7	7	9
RY8	15	15	18

Sold & Serviced By:

ELECTROMATE

Toll Free Phone (877) SERV098

Toll Free Fax (877) SERV099

www.electromate.com

sales@electromate.com

FLANGE MOUNTED-POWER ON BRAKES

24 VDC and 90 Volts DC 3/16", 1/4", 5/16", and 3/8" Bores

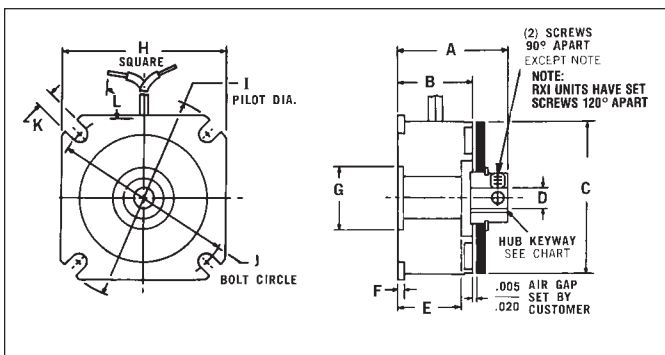

Mechanical

PIC Series	Static Torque Lb-In	Inertia Lb-In ²	Wgt. Oz.
		Arm & Hub	
RX1	2.5	.0011	2
RX2	6	.0024	3.2
RX3	10	.026	3.8
RX4	15	.031	11

Electrical

PIC Series	90 VDC		24 VDC	
	Amps	Ohms	Amps	Ohms
RX1	.046	1977	.117	205
RX2	.047	1930	.198	121
RX3	.042	2150	.183	132
RX4	.066	1369	.289	83

D Nom.	Voltage	Part No.		
			3/16	90 VDC
3/16	24 VDC	RX1-302		
1/4	90 VDC	RX1-103		
1/4	24 VDC	RX1-303		
1/4	90 VDC	RX2-103		
1/4	24 VDC	RX2-303		
5/16	90 VDC	RX2-104		
5/16	24 VDC	RX2-304		
5/16	90 VDC	RX3-104		
5/16	24 VDC	RX3-304		
3/8	90 VDC	RX3-105		
3/8	24 VDC	RX3-305		
Key Way	1/32 x 1/16	5/16	90 VDC	RX4-104
		5/16	24 VDC	RX4-304
	3/64 x 3/32	3/8	90 VDC	RX4-105
		3/8	24 VDC	RX4-305

To Order Alternate Bores and Voltages, Consult Factory

PIC Series	A	B Nom.	C Max.	E Nom.	F Max.	G ±.001	H Max.	I ±.001	J Nom.	K Min.	L ±.500
RX1	.885	.634	.905	.572	.034	NA	.980	1.1995	1.030	.094	12.0
RX2	.974	.650	1.160	.583	.052	NA	1.230	1.498	1.312	.123	12.0
RX3	1.309	.867	1.500	.805	.063	NA	1.567	1.999	1.750	.156	12.0
RX4	1.269	.848	1.780	.745	.064	NA	1.943	2.436	2.125	.186	12.0

Series	Typical Out-of-Box Torques lb.-in.	Rated Static Torques lb.-in.	Typical Torques After Burnishing lb.-in.
RX1	2	2.5	3
RX2	5	6	8
RX3	8	10	15
RX4	12	15	20

SHAFT MOUNTED-CLUTCHES

24 and 90 Volts DC $\frac{3}{16}$ ", $\frac{1}{4}$ ", $\frac{5}{16}$ ", and $\frac{3}{8}$ " Bores

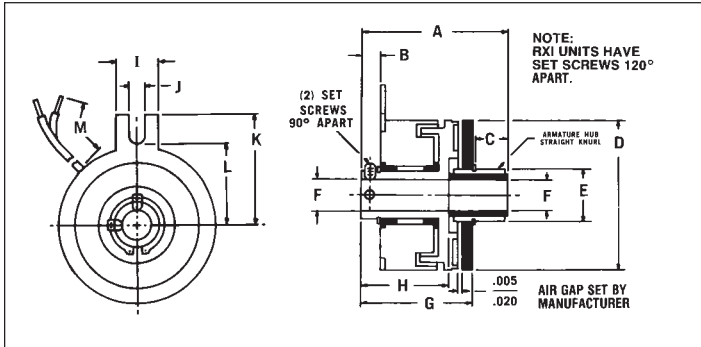

Mechanical

PIC Series	Static Torque Lb-In	Inertia Lb-In ²		Wgt. Oz.
		Rotor	Arm & Hub	
RW1	2.5	.002	.0015	2.0
RW2	6	.0058	.0029	3.2
RW3	10	.060	.0031	3.8
RW4	15	.061	.036	11

Electrical

PIC Series	90 VDC		24 VDC	
	Amps	Ohms	Amps	Ohms
RW1	.046	1977	.117	205
RW2	.047	1930	.198	121
RW3	.042	2150	.183	132
RW4	.066	1369	.289	83

F Nom.	Voltage	Part No.
3/16	90 VDC	RW1-122
3/16	24 VDC	RW1-322
1/4	90 VDC	RW1-133
1/4	24 VDC	RW1-333
1/4	90 VDC	RW2-133
1/4	24 VDC	RW2-333
5/16	90 VDC	RW2-144
5/16	24 VDC	RW2-344
5/16	90 VDC	RW3-144
5/16	24 VDC	RW3-344
3/8	90 VDC	RW3-155
3/8	24 VDC	RW3-355
3/8	90 VDC	RW4-144
3/8	24 VDC	RW4-344
3/8	90 VDC	RW4-155
3/8	24 VDC	RW4-355

To Order Alternate Bores and Voltages, Consult Factory.

Dimensions

PIC Series	A	B Nom.	C	D Max.	E ±.002	G Nom.	H Nom.	I Max.	J Min.	K Nom.	L Nom.	M ±.500
RW1	1.370	.191	.410	.903	.506	.874	.763	.305	.094	.625	.445	12.00
RW2	1.409	.147	.396	1.160	.506	.935	.777	.380	.122	.875	.585	12.00
RW3	1.700	.273	.303	1.500	.630	1.255	1.075	.520	.180	1.120	.750	12.00
RW4	1.823	.270	.355	1.780	.630	1.314	1.060	.505	.184	1.325	.975	12.00

Series	Torque Build-up Time — Milliseconds				Torque Decay Time MS
	Rated Static Torque lb.-in.	65% of Rated Torque	80% of Rated Torque	100% of Rated Torque	
RW1	2.5	3.3	4.8	7.5	6.6
RW2	6	5.5	7.2	10.5	11
RW3	10	6	9	12	17
RW4	15	8	10	14	14

SLIP CLUTCHES — CONTINUOUS SLIP OPERATION

$\frac{1}{8}$ ", $\frac{3}{16}$ ", and $\frac{1}{4}$ " Bores and 3, 4, 6 mm Bores

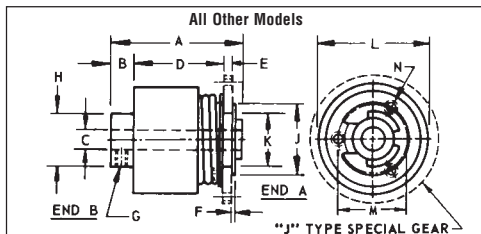
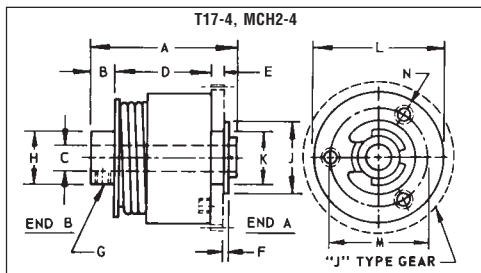

Pre-set Slip Torque Bi-directional (oz. in.)	A	B	C +.0006 -0.0000	D	E	F	G	H	J	K +.0000 -0.0008	L	M	N	Part No.
9 ± 1	1.05	.18	.1248	.72	.080	.03	#2-56	.38	.45	.3740	.63	.500	#0-80 x .08 deep	T17-1
20 ± 2	1.24	.21	.1873	.85	.095	.04	#4-40	.50	.68	.4990	1.00	.650	#1-72 x .10 deep	T17-2
20 ± 2	1.24	.21	.2498	.85	.095	.04	#4-40	.50	.68	.4990	1.00	.650	#1-72 x .10 deep	T17-3
48 ± 5	1.39	.23	.2498	.94	.130	.04	#6-32	.50	.68	.4990	1.25	.925	#2-56 x .11 deep	T17-4
80 ± 8	1.39	.23	.2498	.94	.130	.04	#6-32	.63	.68	.4990	1.50	.925	#2-56 x .11 deep	T17-5
120 ± 12	1.67	.25	.2498	1.20	.130	.04	#6-32	.63	.59	.4990	1.87	.780	#4-40 x .15 deep	T17-6

Dimensions below are in millimeters.

Pre-set Slip Torque Bi-directional (N-m)	A	B	C +0.015 -0.000	D	E	F	G	H	J	K +0.00 -0.02	L	M	N	Part No.
0.064 ± 0.007	26.67	4.57	2.995	18.29	2.03	0.76	M2X.4	9.65	11.43	9.500	16.00	12.70	#0-80 x $\frac{.08}{25.4}$ deep	MCH2-1
0.141 ± 0.014	31.50	5.33	3.995	21.59	2.41	1.02	M2X.4	12.70	17.27	12.675	25.40	16.51	#1-72 x $\frac{.10}{25.4}$ deep	MCH2-2
0.141 ± 0.014	31.50	5.33	5.995	21.59	2.41	1.02	M3X.5	12.70	17.27	12.675	25.40	16.51	#1-72 x $\frac{.10}{25.4}$ deep	MCH2-3
0.339 ± 0.035	35.31	5.84	5.995	23.88	3.30	1.02	M3X.5	12.70	17.27	12.675	31.75	23.50	#2-56 x $\frac{.11}{25.4}$ deep	MCH2-4
0.565 ± 0.057	35.31	5.84	5.995	23.88	3.30	1.02	M3X.5	16.00	17.27	12.675	38.10	23.50	#2-56 x $\frac{.11}{25.4}$ deep	MCH2-5
0.847 ± 0.085	42.42	6.35	5.995	30.48	3.30	1.02	M3X.5	16.00	14.99	12.675	47.50	19.81	#4-40 x $\frac{.15}{25.4}$ deep	MCH2-6

FEATURES

- Mounting provision for modified "J" Gears, Pulleys and Sprockets
- Stainless Steel with Bronze Bearings
- Same or Different Torques Available for Two Directions of Rotation - See Special Ordering Information
- Precise and stable limit Torque
- Same Torque at breakaway as at high slip velocity
- Torque Range: 2 to 120 Oz. In.

Higher Torques - To 240 Oz. In.
Larger Bores - To $\frac{1}{2}$ "
Available on Request

*SPECIALS	
Torque Range	
Max. Oz. In.	Min. Oz. In.
9 ± 1	2 ± .5
20 ± 2	5 ± 1
20 ± 2	5 ± 1
48 ± 5	10 ± 1.5
80 ± 8	20 ± 3
120 ± 12	30 ± 4

TO ORDER SPECIAL TORQUE SETTINGS:

Refer to Torque Range Min. — Max. values to obtain the practical Torque Ranges available for each basic clutch.

SPECIFY: Basic Part Number — Required Torque for End A, CW Rotation — Required Torque for End A, CCW Rotation.

EXAMPLE: Special Slip Clutch:

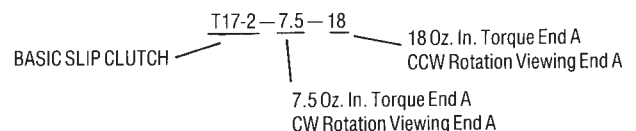

SLIP CLUTCHES — CONTINUOUS SLIP OPERATION

Adjustable Torque

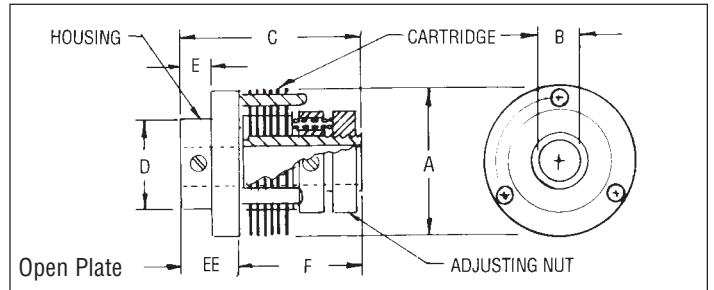

Material:

- Housing — Steel; Zinc Plated
- Clutch Plates — Brass
- Friction Plates — Proprietary (Non Asbestos)

$$\text{Maximum RPM} = \frac{\text{WATTS (From Table Below)}}{\text{Torque (oz.- in.)} \times .0007}$$

Dimensions And Capacity Rating										
A	Bore B +.002 -.000	C	D ±.005	E	EE	F	Capacity		Friction Surfaces	Part No*
							oz.- in.	Watts		
1.00	.250	1.06	.76	.25	Cartridge Enclosed		.3 to 32	1.0	2	T25-164-2S T25-164-2H
1.00	.250	1.31	.76	.25			4.8 to 160	5.8	8	T25-164-8S T25-164-8H
1.25	.250	1.50	.76	.25	.50	1.00	1.6 to 160	6.0	8	T25-204-S T25-204-H
1.50	.375	2.50	1.01	.37	.75	1.75	8 to 400	14.5	12	T25-246-S T25-246-H
2.00	.500	2.87	1.38	.50	1.00	1.88	12.8 to 800	29.0	12	T25-328-S T25-328-H

Features:

- A multi plate slip clutch
- Adjustable torque
- Preset torque available on special orders (Torque setting ± 10%)
- Can be used as a slip coupling
- Backlash of 6° is standard
- Constant tension
- Overload protection
- Controlled slip
- Clutches exhibit same torque in either direction
- Shaft to shaft/coupling or thru shaft to pulley, gear, etc.
- Bronze bearing in housing for thru-shaft to pulley models
- Low stick-slip ratio

Capacity at continuous duty, 50 RPM, 25 million cycles (Rev)

- *Note:
- For shaft to shaft coupling, set screws in both housing and cartridge — use Part No. ending with "S"
 - For thru shaft to housing (pulley, gear, etc.), bronze bearing in housing, set screw in cartridge — use Part No. ending with "H"
 - Metric bores can be accomplished by use of bore reducers (5,6,8 & 10 mm finished bores) found in the catalog
 - Consult factory for other bore sizes

SLIP COUPLINGS — CONTINUOUS SLIP OPERATION

1/8", 3/16", and 1/4" Bores and 3, 4, 6 mm Bores

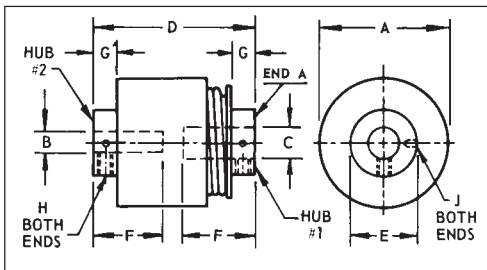

FEATURES

- Misalignment Allowance between shafts - 0.006"
- Stainless Steel
- Same or Different Torques Available for Two Directions of Rotation - See Special Ordering Information
- Torque Range: 1 to 120 Oz. In.
- Precise and stable limit Torque
- Same Torque at breakaway as at high slip velocity

*SPECIALS	
Torque Range	
Max. Oz. In.	Min. Oz. In.
12 ± 1.2	3 ± .5
20 ± 2	5 ± 1
48 ± 5	10 ± 1.5

Inch Bores Toler. +.0005 -.0000	Pre-Set Slip Torque Bi- directional	A	B	C	D	E Max	F	G	H	Part No.
20 ± 2 Oz. In.	1.00	.1875 .1875 .2500	.1875 2500 2500	1.26	.63	.55	.19	#4-40	T18-7 T18-8 T18-9	
48 ± 5 Oz. In.	1.25	.2500 .2500 .3750	.2500 3750 3750	1.43	1.01	.62	.25	#6-32	T18-10 T18-11 T18-12	
Dimensions below are in millimeters.										
Metric Bores Toler. +.013 -.000	0.035 ± 0.005 N-m	12.70	3	3	22.60	12.5	10.92	4.32	M2X.4	MCU17-1
			3	4						MCU17-2
			4	4						MCU17-3
	0.085 ± 0.008 N-m	19.05	4	4	28.19	16	12.70	4.83	M2X.4	MCU17-4
			4	6						MCU17-5
			6	6						M3X.5
0.141 ± 0.014 N-m	25.40	4	4	32.00	16	13.97	4.83	M2X.4	MCU17-7	
		4	6						MCU17-8	
		6	6						M3X.5	MCU17-9

Special Bores - 1/8 to 1/2
Higher Torques - To 240 Oz. In.
Larger Bores - To 1/2"
Available on Request

TO ORDER SPECIAL TORQUE SETTINGS:

Refer to Torque Range Min. — Max. values to obtain the practical Torque Ranges available for each basic coupling.

EXAMPLE: Special Slip Coupling:

T18-10 — 12 — 44 — 44 Oz. In. Torque Hub = 1, CCW Rotation Viewing End A

BASIC SLIP COUPLING — 12 Oz. In. Torque Hub = 1, CW Rotation Viewing End A

SPECIFY: Basic Part Number — Required Torque for Hub #1. Rotating CW — Required Torque for Hub #1. Rotating CCW.

SLIP CLUTCH ASSEMBLY — ADJUSTABLE-MOMENTARY OVERLOAD*

Pin Hub = 1/8", 3/16", and 1/4" Bores and 3, 4, 6 mm Bores

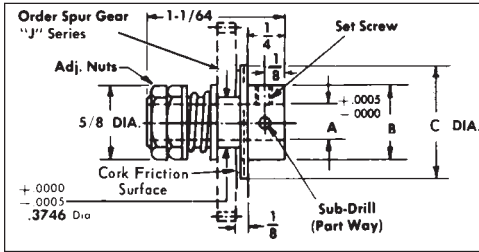

Part No.	Friction Surface
MCH3-2, -4, -6	Pads
MCH3-1, -3, -5	Ring

ADJUSTABLE TO 0.07 N-m
AVAILABLE WITH 0.07 TO 0.35 N-m ON REQUEST

Part No.	Friction Surface
R3-3	Pads
R3-10, 11, 12	Ring

ADJUSTABLE TO 10 OZ. IN. TORQUE FOR 10 TO 50 OZ. IN. TORQUE ADD 50 TO CAT. NO.

Inch Bores Toler. +.0005 - .0000	Shaft Size	A	B	C	Set Screw	Part No.
	1/8	.1248	.312	5/8	#2-56	R3-10
	3/16	.1873	.375	5/8	#4-40	R3-11
	1/4	.2498	.500	5/8	#6-32	R3-12 R3-3

Dimensions below are in millimeters.

Metric Bores Toler. +.013 - .000	Shaft Size	A	B	C	Set Screw	Part No.
	3	2.995	7.92	15.88	M2X.4	MCH3-1 MCH3-2
	4	3.995	9.52	15.88	M2X.4	MCH3-3 MCH3-4
	6	5.995	12.70	15.88	M3X.5	MCH3-5 MCH3-6

*Not to be used for continuous slippage. For continuous Duty Slip Clutch See T17, MCH2 Series.

Material: Stainless Steel

Clamp Type = 1/8", 3/16", and 1/4" Bores and 3, 4, 6 mm Bores

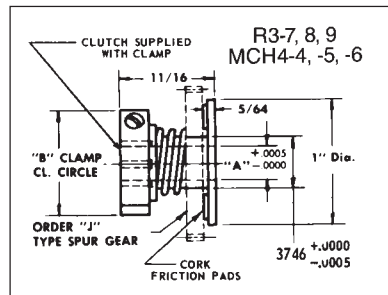
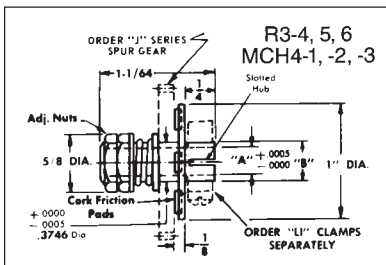

Inch Bores Toler. +.0005 - .0000	Shaft Size	A	B	Clamp	Part No.
	1/8	.1248	.188	L1-4	R3-4
	3/16	.1873	.250	L1-5	R3-5
	1/4	.2498	.312	L1-6	R3-6
	1/8	.1248	7/8	L1-4	R3-7
	3/16	.1873	1-1/32	L1-5	R3-8
	1/4	.2498	1-1/8	L1-6	R3-9

Dimensions below are in millimeters.

Metric Bores Toler. +.013 - .000	Shaft Size	A	B	Clamp	Part No.
	3	2.995	4.78	L1-4	MCH4-1
	4	3.995	6.35	L1-5	MCH4-2
	6	5.995	7.92	L1-6	MCH4-3
	3	2.995	22.23	L1-4	MCH4-4
	4	3.995	26.19	L1-5	MCH4-5
	6	5.995	28.58	L1-6	MCH4-6

Material: Stainless Steel

*Not to be used for continuous slippage. For continuous Duty Slip Clutch See T17, MCH2 Series.

IN-LINE COUPLING & SLIP CLUTCHES — ADJUSTABLE-INTERMITTENT DUTY

1/8", 3/16", and 1/4" Bores and 3, 4, 6 mm Bores

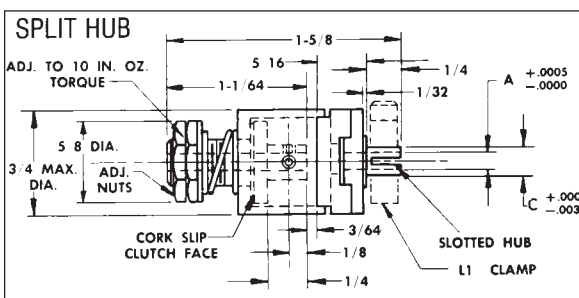
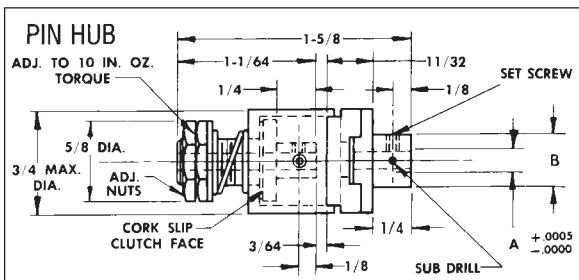

Inch Bores Toler. +.0005 - .0000	*Shaft Size	*A	B	C	Set Screw	Clamp No. (Ref.)	Pin Hub Part No.	Split Hub Part No.
	1/8 to 3/16	.1248 .1873	.37	.250	#4-40	L1-5	T14-7	T14-10
	3/16 to 3/16	.1873	.37	.250	#4-40	L1-5	T14-2	T14-5
	3/16 to 1/4	.1873 .2498	.50	.312	#6-32	L1-6	T14-9	T14-12
	1/4 to 1/4	.2498	.50	.312	#6-32	L1-6	T14-3	T14-6

Dimensions below are in millimeters.

Metric Bores Toler. +.013 - .000	*Shaft Size	*A	B	C	Set Screw	Clamp No. (Ref.)	Pin Hub Part No.	Split Hub Part No.
	3 to 3	2.995	7.92	4.78	M2X.4	L1-4	MCU18-1	MCU19-1
	3 to 4	2.995 3.995	9.52	6.35	M2X.4	L1-5	MCU18-2	MCU19-2
	3 to 6	2.995 5.995	12.70	7.92	M2X.4	L1-6	MCU18-3	MCU19-3
	4 to 4	3.995	9.52	6.35	M2X.4	L1-5	MCU18-4	MCU19-4
	4 to 6	3.995 5.995	12.70	7.92	M2X.4	L1-6	MCU18-5	MCU19-5
	6 to 6	5.995	12.70	7.92	M3X.5	L1-6	MCU18-6	MCU19-6

*Adjustable End is first shaft size shown.

For 10 to 50 in. oz. Torque Adjustment, Add - 50 to Part Number. Available with 0.07 to 0.35 N-m on Request.

Material: 303 Stainless Steel

ROLLER CLUTCHES

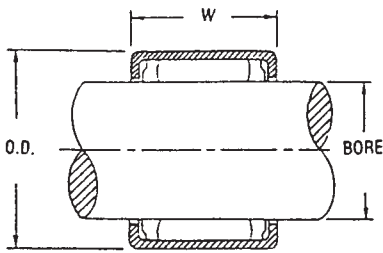

Lock Function
 Shaft Drives Gear
 Clockwise (top arrows)
 or
 Gear Can Drive Shaft
 Counter-Clockwise
 (bottom arrows)

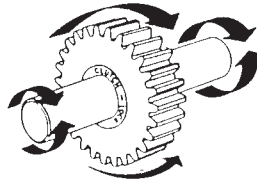

Overrun Function
 Shaft Overruns in Gear
 Counter-Clockwise
 (top arrows)
 or
 Gear Overruns on
 Shaft Clockwise
 (bottom arrow)

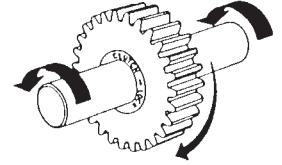

Material:
 Roller Cup - Case Hardened Steel
 Needle Bearing - 52100 Hardened
 Chrome Steel
 Cage: Acetal with Integral leaf springs

- Ideal for indexing, backstopping or overrunning operations
- Free rolling one way, drives in opposite direction
- Light weight, low profile
- High indexing, frequency
- Temperature max 200°F
- Maximum Backlash
- Shaft should be RC58 min. with 16μ" finish or better

Bore	O.D.	W +.000 -.010	Torque Rating In Lb.	Overrun Limiting Speed RPM	Mounting Dim.		Part No.
					Shaft Dia. +.0000 -.0005	Hsg. Bore Dia. +.001 -.000	
1/8	9/32	.250	2.86	50,000	.1250	.2812	EC-02-04
1/4	7/16	.500	17.2	21,000	.2500	.4370	EC-04-07
3/8	5/8	.500	45.4	14,000	.3750	.6245	EC-06-10
1/2	3/4	.500	73.6	11,000	.5000	.7495	EC-08-12
5/8	7/8	.625	143	8,500	.6250	.8745	EC-10-14
3/4	1	.625	196	7,000	.7500	.9995	EC-12-16

BACKLASH FREE ELASTOMER JAW "SPIDER" COUPLING

1/8" to 1/2" Diameter Bores and 4mm to 12mm Bores

Features:

- For electrical isolation and chemical resistance
- Coupling with Integral radial clamp using socket head cap screws
- High torsional stiffness:
 - Static 4.5 Lbf-Ft/deg (700Nm/rad)
 - Dynamic 9 Lbf-Ft/deg (350Nm/rad)
- Misalignment Tolerances:
 - Angular 0.8°
 - Lateral .002" (.06 mm)
 - Axial ± .039" (1 mm)
- Temp. Range (due to elastomer)
 22° to 248°F (-30° to 120°C)

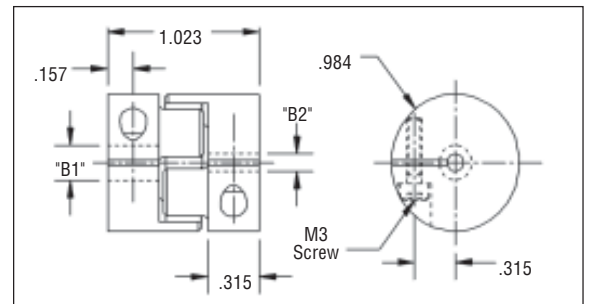
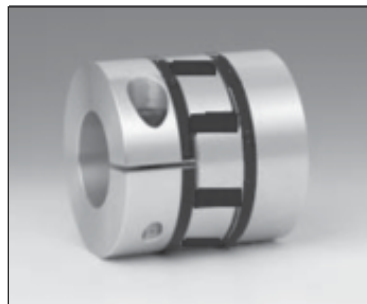

Specifications: Inch / (Metric)

- Rated Torque 106 Lbf-in / (12Nm)
- Over all length 1.02" / (26mm)
- C Fit Length .315" / (8mm)
- Clamping Screw M3
- Torque to tighten screw 17.7 Lbf-in / (2Nm)
- Aprox. Weight .07 oz / (.02 kg)
- Bore Tolerance +.001" / (H7)
 -.000

Material:

- Hubs: High Strength Aluminum
- Elastomer Insert: Precision molded, wear resistant and thermally stable polymer 64 Shore D

Inch bores

B ₁ / B ₂ Bore	Part Number
.188	T13E-18
.250	T13E-25
.250/.188	T13E-2518
.3125	T13E-31
.3125/.188	T13E-3118
.3125/.250	T13E-3125
.375	T13E-37
.375/.188	T13E-3718

Inch bores

B ₁ / B ₂ Bore	Part Number
.375/.250	T13E-3725
.375/.3125	T13E-3731
.500	T13E-50
.500/.188	T13E-5018
.500/.250	T13E-5025
.500/.3125	T13E-5031
.500/.375	T13E-5037

Metric Bores

B ₁ / B ₂ Bore	Part Number
4	T13E-4M
5	T13E-5M
5/4	T13E-5M4M
6	T13E-6M
6/5	T13E-6M5M
6/4	T13E-6M4M
8	T13E-8M
8/4	T13E-8M4M
8/5	T13E-8M5M
8/6	T13E-8M6M
12/10	T13E-12M10M

Metric to Inch

B ₁ / B ₂ Bore	Part Number
4M/.188	T13E-4M18
5M/.188	T13E-5M18
4M/.250	T13E-4M25
5M/.375	T13E-5M37
6M/.375	T13E-6M37
4M/.500	T13E-4M50
6M/.500	T13E-6M50
10M/.500	T13E-10M50
12M/.500	T13E-12M50

Other bore sizes and combinations available between inch (.188 to .500) and metric (4mm to 12mm) ranges. Please consult factory.

WAFER SPRING COUPLINGS

.12 To .50 Inch Bores and 3 To 12 mm Bores

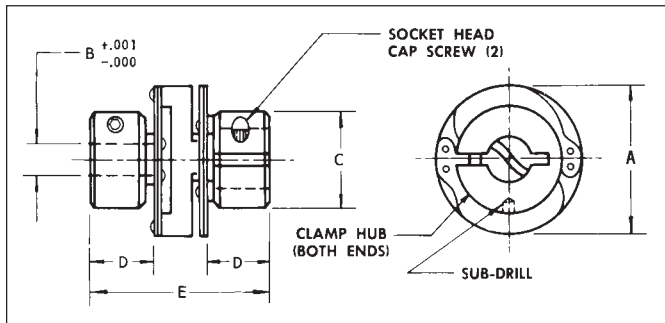

Material: Hubs and center members – Anodized Aluminum
 Leaves – 17-7PH S.S.
 Fasteners – Stainless Steel

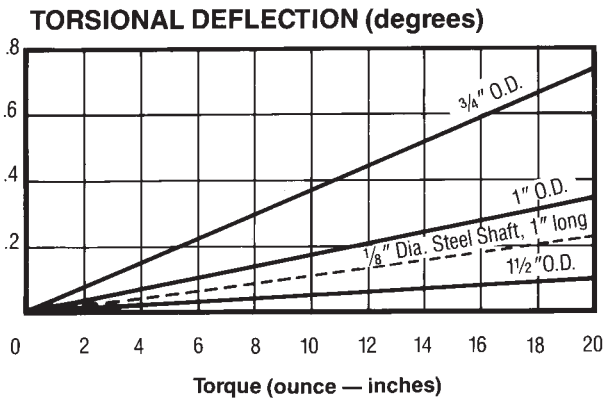
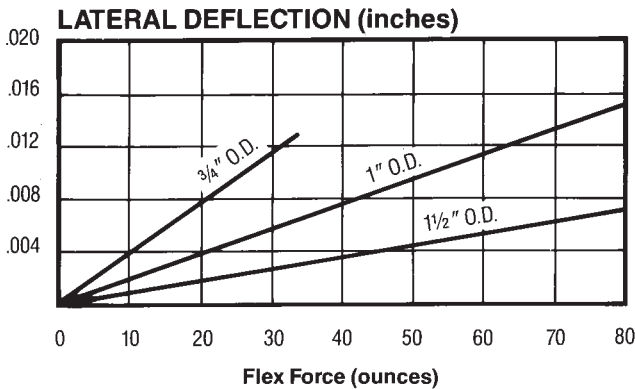

Inch Bores Toler. +.001 - .000	B	A	C	D	E	Set Screw	Part No.
	.1200/.1250 .1200/.1875 .1200/.2500 .1250 .1250/.1875 .1875 .1875/.2500 .2500	3/4	9/16	19/64	7/8	#2-56	T15-1 T15-3 T15-4 T15-5 T15-7 T15-12 T15-13 T15-14
.1875 .1875/.2500 .2500 .2500/.3125 .3125	1	.75	.44	1.25	#4-40	T15-22 T15-23 T15-24 T15-25 T15-26	
.2500/.3125 .2500/.3750 .3125 .3125/.3750 .3750 .3750/.5000 .5000	1-1/2	1	21/32	1-13/16	#6-32	T15-15 T15-16 T15-17 T15-18 T15-19 T15-20 T15-21	
Dimensions below are in millimeters.							
Metric Bores Toler. +.025 - .000	3 to 3 3 to 4 3 to 6 4 to 4 4 to 6 6 to 6	19.05	14.22	7.62	22.35	M2X.4	MCU15-1 MCU15-2 MCU15-3 MCU15-4 MCU15-5 MCU15-6
	6 to 6 6 to 8 8 to 8	25.40	19.05	11.18	31.75	M3X.5	MCU15-7 MCU15-8 MCU15-9
	6 to 8 8 to 8 8 to 10 10 to 10 10 to 12 12 to 12	38.10	25.40	16.76	45.97	M4X.7	MCU15-10 MCU15-11 MCU15-12 MCU15-13 MCU15-14 MCU15-15

Model No.	O.D. (A)	Torque (Oz-In) Max.	Angular Deflection		Lateral Deflection		Max. Axial Deflection (inches)
			Flex Force* (oz.)	Degrees Max.	Flex Force* (oz.)	Inches Max.	
T15-1 thru 14 MCU15-1 thru MCU15-6	3/4"	165	5.2	8	48	.018	.023
T15-22 thru 26 MCU15-7 thru MCU15-9	1"	225	13.0	8	108	.020	.030
T15-15 thru 21 MCU15-10 thru MCU15-15	1 1/2"	440	26.0	8	344	.030	.045

*The force required to flex coupling to maximum deflection, applied at point one diameter from coupling center. This force is constant through 360° rotation.

Maximum speed 5000 RPM

Sold & Serviced By:

ELECTROMATE

Toll Free Phone (877) SERV098

Toll Free Fax (877) SERV099

www.electromate.com

sales@electromate.com

BELLOWS COUPLINGS

.12 to 3/8" Bore and 3 mm to 10 mm Bores

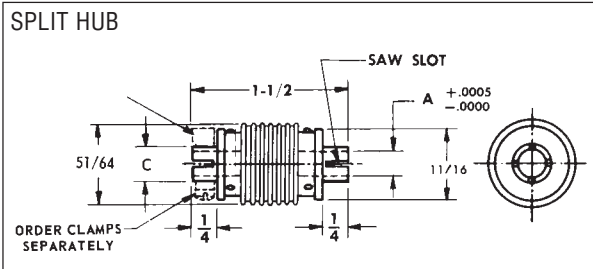
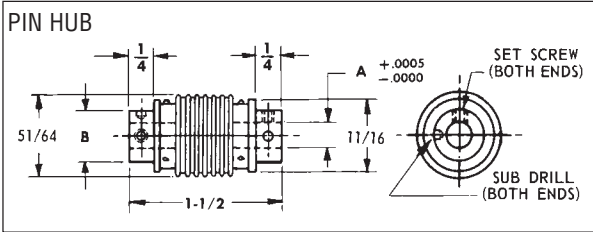

Material: Stainless Steel

Torque 75 oz. in.
 Shaft to Shaft Misalignment 0.010"
 Angular Misalignment 5°
 Backlash Negligible

	Shaft Size	A	B	C	Set Screw	Clamp No. (Ref.)	Pin Hub Part No.	Split Hub Part No.
Inch Bores Toler. +.0005 -.0000	.12 to 1/8	.1200 .1248	.312	.188	#2-56	L1-4	T1-15	T1-18
	.12 to 1/4	.1200 .2498	.312 .500	.188 .312	#2-56 #6-32	L1-4 L1-6	T1-17	T1-20
	1/8 to 1/8	.1248	.312	.188	#2-56	L1-4	T1-1	T1-8
	1/8 to 3/16	.1248 .1873	.312 .375	.188 .250	#2-56 #4-40	L1-4 L1-5	T1-4	T1-11
	1/8 to 1/4	.1248 .2498	.312 .500	.188 .312	#2-56 #6-32	L1-4 L1-6	T1-5	T1-12
	3/16 to 3/16	.1873	.375	.250	#4-40	L1-5	T1-2	T1-9
	3/16 to 1/4	.1873 .2498	.375 .500	.250 .312	#4-40 #6-32	L1-5 L1-6	T1-6	T1-13
	1/4 to 1/4	.2498	.500	.312	#6-32	L1-6	T1-3	T1-10
	5/16 to 5/16	.3123	.500	.375	#6-32	L1-20	T1-21	T1-23
	3/8 to 3/8	.3748	.625	.438	#8-32	L1-21	T1-22	T1-24

Dimensions below are in millimeters.

Metric Bores Toler. +.013 -.000	3 to 3	2.995	7.92	4.78	M2X.4	L1-4	MCU1-1	MCU2-1
	3 to 4	2.995	7.92	4.78	M2X.4	L1-4	MCU1-2	MCU2-2
		3.995	9.52	6.35		L1-5		
	3 to 6	2.995	7.92	4.78	M2X.4	L1-4	MCU1-3	MCU2-3
		5.995	12.70	7.92		L1-6		
	4 to 4	3.995	9.52	6.35	M2X.4	L1-5	MCU1-4	MCU2-4
		3.995	9.52	6.35		L1-5		
	4 to 6	3.995	9.52	6.35	M2X.4	L1-5	MCU1-5	MCU2-5
		5.995	12.70	7.92		L1-6		
	6 to 6	5.995	12.70	7.92	M3X.5	L1-6	MCU1-6	MCU2-6
	8 to 8	7.995	12.70	9.60	M3X.5	L1-20	MCU1-7	MCU2-7
	10 to 10	9.995	16.40	11.60	M4X.7	L1-21	MCU1-8	MCU2-8

ZERO ADJUSTABLE COUPLINGS

1/8" to 3/8" Bore and 3 mm to 10 mm Bores

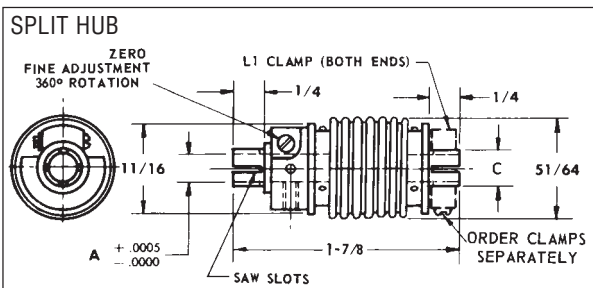
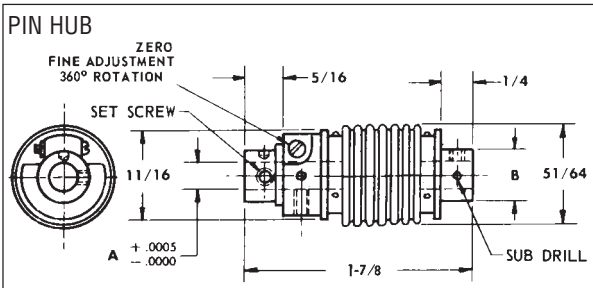

Material: Stainless Steel

	Shaft Size	A	B	C	Set Screw	Clamp No. (Ref.)	Pin Hub Part No.	Split Hub Part No.
Inch Bores Toler. +.0005 -.0000	1/8 to 1/8	.1248	5/16	.188	#2-56	L1-4	T9-1	T10-1
	1/8 to 3/16	.1248	5/16	.188	#2-56	L1-4	T9-7	T10-7
		.1873	3/8	.250	#4-40	L1-5		
	1/8 to 1/4	.1248 .2498	5/16 1/2	.188 .312	#2-56 #6-32	L1-4 L1-6	T9-8	T10-8
	3/16 to 3/16	.1873	3/8	.250	#4-40	L1-5	T9-2	T10-2
	3/16 to 1/4	.1873 .2498	3/8 1/2	.250 .312	#4-40 #6-32	L1-5 L1-6	T9-9	T10-9
	1/4 to 1/4	.2498	1/2	.312	#6-32	L1-6	T9-3	T10-3
	5/16 to 5/16	.3123	.500	.375	#6-32	L1-20	T9-11	T10-11
	3/8 to 3/8	.3748	.625	.438	#8-32	L1-21	T9-12	T10-12

Dimensions below are in millimeters.

Metric Bores Toler. +.013 -.000	3 to 3	2.995	7.92	4.78	M2X.4	L1-4	MCU3-1	MCU4-1
	3 to 4	2.995	7.92	4.78	M2X.4	L1-4	MCU3-2	MCU4-2
		3.995	9.52	6.35		L1-5		
	3 to 6	2.995	7.92	4.78	M2X.4	L1-4	MCU3-3	MCU4-3
		5.995	12.70	7.92		L1-6		
	4 to 4	3.995	9.52	6.35	M2X.4	L1-5	MCU3-4	MCU4-4
		3.995	9.52	6.35		L1-5		
	4 to 6	3.995	9.52	6.35	M2X.4	L1-5	MCU3-5	MCU4-5
		5.995	12.70	7.92		L1-6		
	6 to 6	5.995	12.70	7.92	M3X.5	L1-6	MCU3-6	MCU4-6
	8 to 8	7.995	12.70	9.60	M3X.5	L1-20	MCU3-7	MCU4-7
	10 to 10	9.995	16.40	11.60	M4X.7	L1-21	MCU3-8	MCU4-8

* Adjustable end is first shaft size shown.

One turn of adjusting screw rotates coupling hub 12 degrees. Hub and shaft remain fixed during adjustment.

FLEXIBLE COUPLINGS

.12 to 1/4" Bore and 3 mm to 6 mm Bores

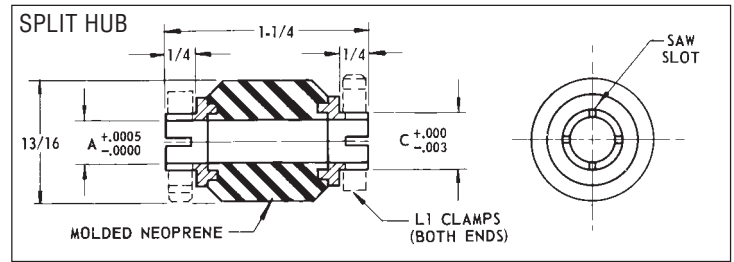
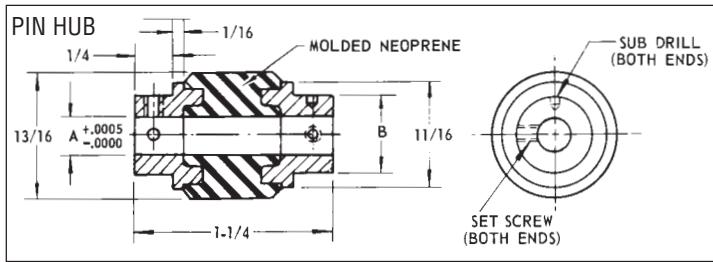

Material: 303 Stainless Steel Hubs.
Neoprene (Center Section)

FEATURES

Allows Shaft Misalignment
Isolates Torsional Vibration
Insulates Between Units

SPECIFICATIONS

MAXIMUM ANGULAR MISALIGNMENT 2°
MAXIMUM LATERAL MISALIGNMENT010"
MAXIMUM WORKING TORQUE 100 OZ-IN
MAXIMUM SPEED 1000 RPM

	Shaft Size	A	B	C	Set Screw	Clamp No. (Ref.)	Pin Hub Part No.	Split Hub Part No.
Inch Bores Toler. +.0005 -.0000	.12 to 1/8	.1200 .1248	5/16	.188	#2-56	L1-4	T11-7	T12-7
	.12 to 3/16	.1200 .1873	5/16 3/8	.188 .250	#2-56 #4-40	L1-4 L1-5	T11-10	T12-10
	.12 to 1/4	.1200 .2498	5/16 1/2	.188 .312	#2-56 #6-32	L1-4 L1-6	T11-9	T12-9
	1/8 to 1/8	.1248	5/16	.188	#2-56	L1-4	T11-1	T12-1
	1/8 to 3/16	.1248 .1873	5/16 3/8	.188 .250	#2-56 #4-40	L1-4 L1-5	T11-4	T12-4
	1/8 to 1/4	.1248 .2498	5/16 1/2	.188 .312	#2-56 #6-32	L1-4 L1-6	T11-5	T12-5
	5/32 to 3/16	.1562 .1873	5/16 3/8	.250	#2-56 #4-40	L1-5	T11-8	T12-8
	3/16 to 3/16	.1873	3/8	.250	#4-40	L1-5	T11-2	T12-2
	3/16 to 1/4	.1873 .2498	3/8 1/2	.250 .312	#4-40 #6-32	L1-5 L1-6	T11-6	T12-6
	1/4 to 1/4	.2498	1/2	.312	#6-32	L1-6	T11-3	T12-3

Dimensions below are in millimeters.

	Shaft Size	A	B	C	Set Screw	Clamp No. (Ref.)	Pin Hub Part No.	Split Hub Part No.
Metric Bores Toler. +.013 -.000	3 to 3	2.995	7.92	4.78	M2X.4	L1-4	MCU7-1	MCU8-1
	3 to 4	2.995	7.92	4.78	M2X.4	L1-4	MCU7-2	MCU8-2
		3.995	9.52	6.35		L1-5		
	3 to 6	2.995	7.92	4.78	M2X.4	L1-4	MCU7-3	MCU8-3
		5.995	12.70	7.92		L1-6		
	4 to 4	3.995	9.52	6.35	M2X.4	L1-5	MCU7-4	MCU8-4
		3.995	9.52	6.35		L1-5		
	4 to 6	5.995	12.70	7.92	M2X.4	L1-5	MCU7-5	MCU8-5
5.995		12.70	7.92	L1-6				
6 to 6	5.995	12.70	7.92	M3X.5	L1-6	MCU7-6	MCU8-6	

Sold & Serviced By:

ELECTROMATE

Toll Free Phone (877) SERV098

Toll Free Fax (877) SERV099

www.electromate.com

sales@electromate.com

UNIVERSAL LATERAL COUPLINGS

1/8", 3/8", and 1/4" Bores and 3, 4, 6 mm Bores

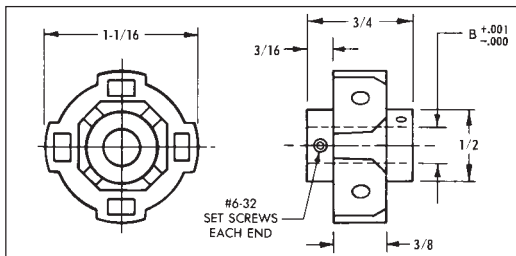

Features

- Simultaneous lateral and angular misalignment
- Corrosion resistant
- Electrically insulated
- Light weight and space saving
- No lubrication required
- Separable

Specifications

Maximum angular misalignment: 10°
Maximum lateral misalignment: .050 inches
Maximum working torque: 15 lb. in.
Backlash: Negligible
Weight (1/2" bore): .5 ounces
Trunnion material: Nickel plated metal
Annular ring material: Delrin
Standard connection to shaft: Socket head cup point set screw

INCH			METRIC		
Tolerance	B	Part No.	Tolerance	B	Part No.
+.001" -.000"	.1200	T16-7	+.025 mm -.000 mm	3	MUJ1-1
	.1200 & .1250	T16-8		4	MUJ1-4
	.1250	T16-1		3 & 4	MUJ1-2
	.1250 & .1875	T16-2		3 & 5	MUJ1-7
	.1250 & .250	T16-3		3 & 6	MUJ1-3
	.1875	T16-4		4 & 5	MUJ1-8
	.1875 & .250	T16-5		4 & 6	MUJ1-5
	.1875 & .3125	T16-9		5 & 5	MUJ1-9
	.2500	T16-6		5 & 6	MUJ1-10
	.2500 & .3125	T16-10		6	MUJ1-6
.3125	T16-11				

INCH TO METRIC

Tolerance	B	Part No.
Inch Bores	.1875" & 5 mm	T16C4-9
+.001"	.1875" & 6 mm	T16C4-6
-.000"	.2500" & 3 mm	T16C6-1
Metric Bores	.2500" & 4 mm	T16C6-4
+.025 mm	.2500" & 5 mm	T16C6-9
-.000 mm	.2500" & 6 mm	T16C6-6

MULTI-JAW COUPLINGS — 64 PITCH

1/8", 3/16", and 1/4" Bores and 3, 4, 6 mm Bores

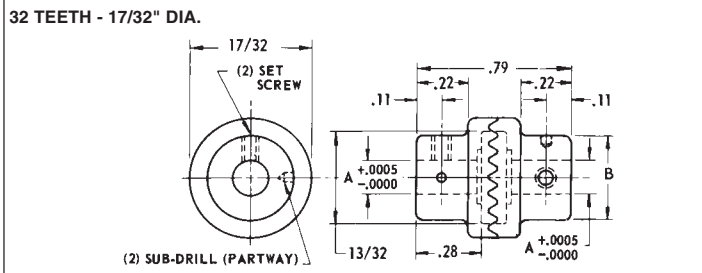
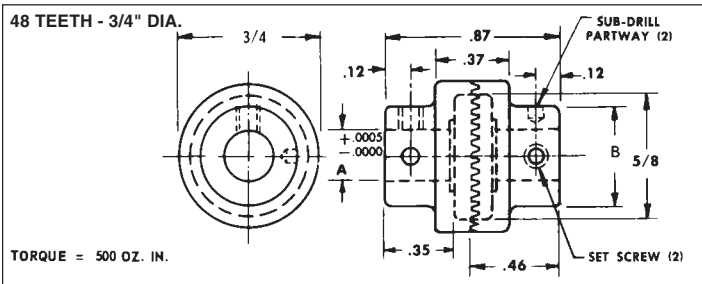

Material: 303 Stainless Steel

Inch Bores Toler. +.0005 - .0000	Shaft Size	A	B	Set Screw	48 Teeth Part No.	32 Teeth Part No.
	1/8 to 1/8	.1248	.31	#2-56	N4-1	N5-1
1/8 to 3/16	.1248 .1873	.31 .37	#2-56 #4-40	N4-6	N5-6	
1/8 to 1/4	.1248 .2498	.31 .50	#2-56 #6-32	N4-7	N5-7	
3/16 to 3/16	.1873	.37	#4-40	N4-2	N5-2	
3/16 to 1/4	.1873 .2498	.37 .50	#4-40 #6-32	N4-8	N5-8	
1/4 to 1/4	.2498	.50	#6-32	N4-3	N5-3	

Dimensions below are in millimeters.

Metric Bores Toler. +.013 - .000	3 to 3	2.995	7.92	M2X.4	MCU13-1	MCU14-1
	3 to 4	2.995 3.995	7.92 9.52	M2X.4	MCU13-2	MCU14-2
3 to 6	2.995 5.995	7.92 12.70	M2X.4	MCU13-3	MCU14-3	
4 to 4	3.995	9.52	M2X.4	MCU13-4	MCU14-4	
4 to 6	3.995 5.995	9.52 12.70	M2X.4	MCU13-5	MCU14-5	
6 to 6	5.995	12.70	M3X.5	MCU13-6	MCU14-6	

MINIATURE OLDHAM COUPLINGS

1/8", 3/16", and 1/4" Bores and 3, 4, 6 mm Bores

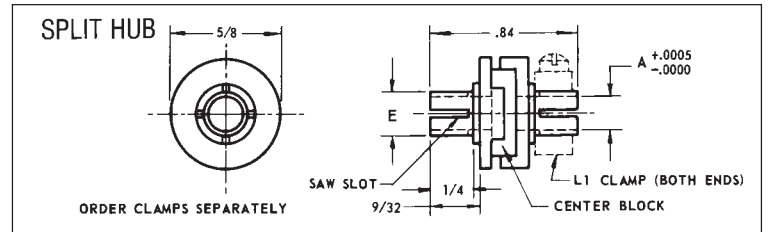
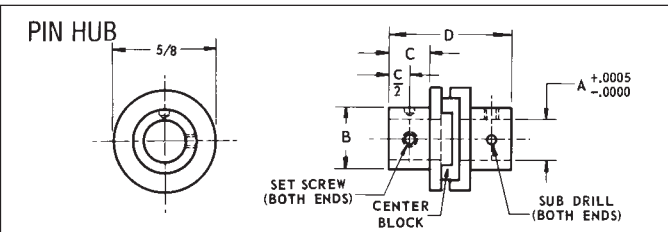

Material:

Hubs — 303 Stainless Steel

Center Block — Oil-Impregnated Bronze For Nylon, add - N to Part Number

***SPECIFICATIONS**

- Torque 50 oz. in.
- Shaft to Shaft Misalignment008
- Angular Misalignment 1°
- Max. Backlash 10'
- Max. Speed 1000 rpm

Inch Bores Toler. +.0005 - .0000	Shaft Size	A	B	C	D	E	Set Screw	Clamp No. (Ref.)	Pin Hub Part No.	Split Hub Part No.
	1/8 to 1/8	.1248	5/16	3/16	21/32	.188	#2-56	L1-4	T7-1	T8-1
1/8 to 3/16	.1248 .1873	5/16 3/8	3/16 7/32	11/16	.188 .250	#2-56 #4-40	L1-4 L1-5	T7-5	T8-5	
1/8 to 1/4	.1248 .2498	5/16 1/2	3/16 1/4	23/32	.188 .312	#2-56 #6-32	L1-4 L1-6	T7-6	T8-6	
3/16 to 3/16	.1873	3/8	7/32	23/32	.250	#4-40	L1-5	T7-2	T8-2	
3/16 to 1/4	.1873 .2498	3/8 1/2	7/32 1/4	3/4	.250 .312	#4-40 #6-32	L1-5 L1-6	T7-7	T8-7	
1/4 to 1/4	.2498	1/2	1/4	25/32	.312	#6-32	L1-6	T7-3	T8-3	

Dimensions below are in millimeters.

Metric Bores Toler. +.013 - .000	3 to 3	2.995	7.92	4.76	16.67	4.78	M2X.4	L1-4	MCU9-1	MCU10-1
	3 to 4	2.995 3.995	7.92 9.52	4.76 5.56	17.46	4.78 6.35	M2X.4	L1-4 L1-5	MCU9-2	MCU10-2
3 to 6	2.995 5.995	7.92 12.70	4.76 6.35	18.26	4.78 7.92	M2X.4	L1-4 L1-6	MCU9-3	MCU10-3	
4 to 4	3.995	9.52	5.56	18.26	6.35	M2X.4	L1-5	MCU9-4	MCU10-4	
4 to 6	3.995 5.995	9.52 12.70	5.56 6.35	19.05	6.35 7.92	M2X.4	L1-5 L1-6	MCU9-5	MCU10-5	
6 to 6	5.995	12.70	6.35	19.84	7.92	M3X.5	L1-6	MCU9-6	MCU10-6	



Toll Free Phone (877) SERV098
Toll Free Fax (877) SERV099
www.electromate.com
sales@electromate.com

PRECISION SLEEVE COUPLINGS

1/8" to 1/2" Bores and 3 to 12 mm Bores

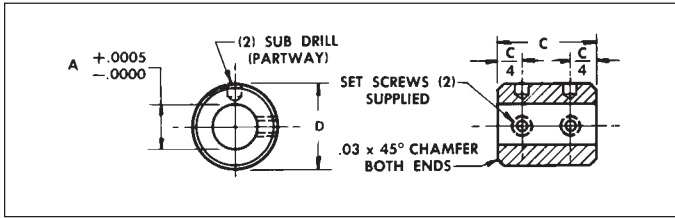

Material: 303 Stainless Steel

Inch Bores Toler. +.0005 - .0000	Shaft Size	A	C	D	Set Screw	Part No.
	1/8	.1248	.43	5/16	# 2-56	D1-1
3/16	.1873	.50	3/8	# 4-40	D1-2	
1/4	.2498	.56	1/2	# 6-32	D1-3	
5/16	.3123	.56	9/16	# 6-32	D1-12	
3/8	.3748	.75	3/4	#10-32	D1-13	
1/2	.4998	1.00	1	1/4-20	D1-14	
Dimensions below are in millimeters.						
Metric Bores Toler. +.025 - .000	3	2.995	10.92	7.92	M2X.4	MCU5-1
	4	3.995	12.70	9.52	M3X.5	MCU5-2
	5	4.995	12.70	9.52	M3X.5	MCU5-3
	6	5.995	14.29	12.70	M3X.5	MCU5-4
	8	7.995	14.29	14.29	M4X.7	MCU5-5
	10	9.995	19.05	19.05	M5X.8	MCU5-6
	12	11.995	25.40	25.40	M6X1.0	MCU5-7

PRECISION SLEEVE COUPLINGS

1/8" to 3/8" Bores and 3 to 12 mm Bores

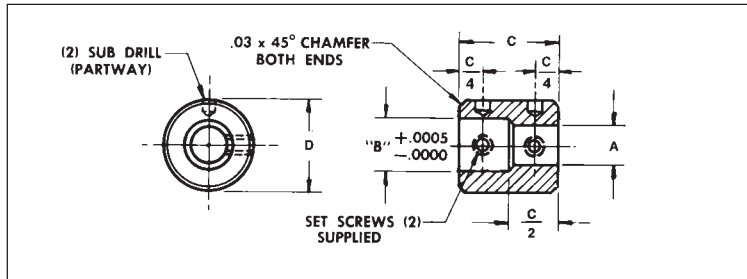

Material: 303 Stainless Steel

Inch Bores Toler. +.0005 - .0000	Shaft Size	A	B	D	C	Set Screw	Part No.
	1/8 to 3/16	.1248	.1873	3/8	.50	# 2-56 # 4-40	D1-9
1/8 to 1/4	.1248	.2498	1/2	.56	# 2-56 # 6-32	D1-10	
3/16 to 1/4	.1873	.2498	1/2	.56	# 4-40 # 6-32	D1-11	
1/4 to 3/8	.2498	.3748	3/4	.75	# 6-32 #10-32	D1-16	
Dimensions below are in millimeters.							
Metric Bores Toler. +.013 - .000	3 to 4	2.995	3.995	9.52	12.70	M2X.4	MCU6-1
	3 to 6	2.995	5.995	12.70	14.29	M2X.4	MCU6-2
	4 to 6	3.995	5.995	12.70	14.29	M3X.5	MCU6-3
	6 to 8	5.995	7.995	14.29	14.29	M3X.5	MCU6-4
	6 to 10	5.995	9.995	19.05	19.05	M3X.5	MCU6-5
	8 to 10	7.995	9.995	19.05	19.05	M4X.7	MCU6-6
	10 to 12	9.995	11.995	25.40	25.40	M5X.8	MCU6-7

Inch to Metric Couplings					
Shaft Size (Inch to mm)	A* Inch	B** mm	C mm	D mm	Part No.
1/8 to 3	.1248	2.995	19.05	12.70	MCU20-1
1/8 to 4	.1248	3.995	19.05	12.70	MCU20-2
1/8 to 5	.1248	4.995	19.05	12.70	MCU20-3
1/8 to 6	.1248	5.995	19.05	12.70	MCU20-4
3/16 to 3	.1873	2.995	19.05	12.70	MCU20-5
3/16 to 4	.1873	3.995	19.05	12.70	MCU20-6
3/16 to 5	.1873	4.995	19.05	12.70	MCU20-7
3/16 to 6	.1873	5.995	19.05	12.70	MCU20-8
3/16 to 8	.1873	7.995	25.40	19.05	MCU20-9
1/4 to 4	.2498	3.995	19.05	12.70	MCU20-10
1/4 to 5	.2498	4.995	19.05	12.70	MCU20-11
1/4 to 6	.2498	5.995	19.05	12.70	MCU20-12
1/4 to 8	.2498	7.995	25.40	19.05	MCU20-13
1/4 to 10	.2498	9.995	25.40	25.40	MCU20-14
1/4 to 12	.2498	11.995	25.40	25.40	MCU20-15
5/16 to 4	.3123	3.995	25.40	14.22	MCU20-16
5/16 to 5	.3123	4.995	25.40	14.22	MCU20-17
5/16 to 6	.3123	5.995	25.40	14.22	MCU20-18
5/16 to 8	.3123	7.995	25.40	19.05	MCU20-19
5/16 to 10	.3123	9.995	25.40	25.40	MCU20-20
5/16 to 12	.3123	11.995	25.40	25.40	MCU20-21
3/8 to 4	.3748	3.995	25.40	19.05	MCU20-22
3/8 to 5	.3748	4.995	25.40	19.05	MCU20-23
3/8 to 6	.3748	5.995	25.40	19.05	MCU20-24
3/8 to 8	.3748	7.995	25.40	19.05	MCU20-25
3/8 to 10	.3748	9.995	25.40	25.40	MCU20-26
3/8 to 12	.3748	11.995	25.40	25.40	MCU20-27

*Inch Bores Toler. +.0005, -.0000

**Metric Bores Toler. +.013, -.0000

Sold & Serviced By:

ELECTROMATE

Toll Free Phone (877) SERV098

Toll Free Fax (877) SERV099

www.electromate.com

sales@electromate.com

FLEXIBLE-ZERO BACKLASH COUPLING

1/8" to 5/8" Diameter Bores and 4 mm to 12 mm Bores

This Flexible-Zero Backlash Coupling is designed for applications such as drive systems for lead screws, gear boxes, high performance motion control systems for greater system accuracy and reliability.

- Coupling with integral clamp
- High torsional stiffness
- Low radial losses
- One piece construction
- Constant velocity
- Dynamic torque ratings are momentary values. For non-reversing applications divide by 2, divide by 4 for reversing applications.

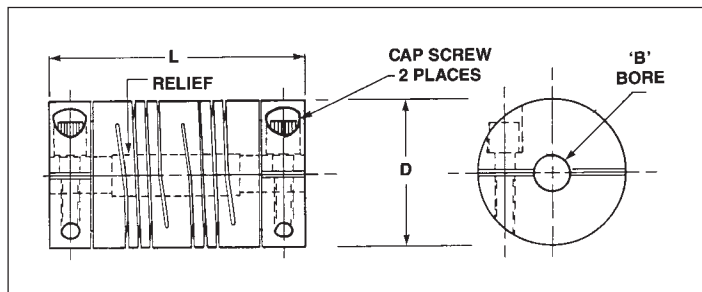

Material: 7075-T6 Aluminum, Clear Anodize
or
17-4 PH Stainless Steel

B Bore +.002 -.000	L Length ±.016	D Dia. ±.016	Integral Clamp Screw Size	Momentary Dynamic Torque Inch Lbs.	Torsional Rate (Degree/Lb In)	Misalignment Tolerances			Part Number
						Angular (Degree)	Parallel Offset (Inches)	Axial Motion (Inches)	
.125	0.750	0.500	1-72	7	0.48	5	.010	±.010	T22S-12
.188	1.250	0.750	4-40	14	0.30	3	.010	±.008	T22A-18
.188	0.900	0.750	4-40	20	0.16	5	.010	±.010	T22S-18
.188/.250	1.060	0.875	6-32	34	0.086	5	0.03	±0.01	T22S-1825S
.250	1.500	1.000	6-32	31	0.13	3	.010	±.008	T22A-25
.250	1.250	1.000	6-32	52	0.062	5	.010	±.010	T22S-25
.250	1.750	1.000	6-32	51	0.098	5	.03	±.010	T22S-25S
.250/.125	0.900	0.750	4-40	8.6	0.68	5	.010	±.010	T22A-2512
.250/.188	1.060	0.875	6-32	17	0.28	5	.010	±.010	T22A-2518
.250/.188	1.250	0.750	4-40	12	0.40	3	.010	±.008	T22A-2518D
.250/.375	1.500	1.000	6-32	25	0.19	3	.010	±.008	T22A-2537
.313	1.500	1.000	6-32	29	0.16	3	.010	±.008	T22A-31
.313	1.250	1.000	6-32	47	0.086	5	.010	±.010	T22S-31
.313/.250	1.750	1.000	6-32	46	0.14	5	0.03	±0.01	T22S-2531
.313/.375	2.375	1.250	10-32	91	0.062	5	0.03	±0.01	T22S-3137
.375	1.750	1.250	10-24	58	0.08	3	.010	±.008	T22A-37
.375	2.375	1.250	10-32	91	0.062	5	.030	±.010	T22S-37
.500	2.250	1.500	10-24	115	0.042	3	.010	±.008	T22A-50
.500	2.625	1.500	10-32	170	0.037	5	.030	±.010	T22S-50
.625	2.500	2.000	1/4-20	215	0.020	3	.010	±.008	T22A-62
.625	3.000	2.000	1/4-28	319	0.018	5	.030	±.010	T22S-62

Dimensions Below are in Millimeters

B Bore +.025 -.000	L ± .40	D ± .40	Screw Size	Nm	Degree/Nm	Misalignment Tolerances			Part Number
						Angular (Degree)	Parallel Offset (Inches)	Axial Motion (Inches)	
3.17	19.05	12.70	1-72	.80	0.054	5	.254	±.254	T22S-12
5.00	38.10	25.40	6-32	3.50	0.015	3	.254	±.203	MT22A-05
5.00	31.75	25.40	6-32	5.88	0.007	5	.254	±.254	MT22S-05
6.00	44.45	31.75	10-24	6.55	0.009	3	.254	±.203	MT22A-06
8.00	60.32	31.75	10-32	10.28	0.007	5	.762	±.254	MT22S-08
10.00	57.15	38.10	10-24	13.00	0.005	3	.254	±.203	MT22A-10
10.00	66.67	38.10	10-32	19.21	0.004	5	.762	±.254	MT22S-10
12.00	63.50	50.80	1/4-20	24.30	0.002	3	.254	±.203	MT22A-12
12.00	76.20	50.80	1/4-28	36.05	0.002	5	.762	±.254	MT22S-12

Sold & Serviced By:

ELECTROMATE

Toll Free Phone (877) SERV098

Toll Free Fax (877) SERV099

www.electromate.com

sales@electromate.com

NOTE: 1. Metric Bore sizes are accomplished by using aluminum bore reducers.
2. T22A-XX denotes aluminum. T22S-XX denotes stainless steel.

(K) FLEXIBLE COUPLINGS

ILLUSTRATION 1

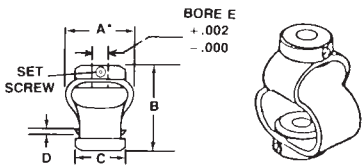
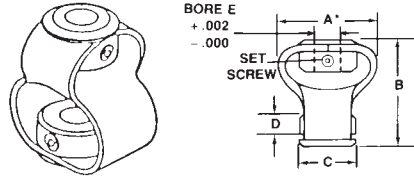

ILLUSTRATION 2



NOTE: Maximum operating speed is 3600 RPM.

Material: Hubs — Zinc Plated Steel
Body — Polyurethane

FEATURES

Hub:

- Zinc plating resists corrosion
- Inside hub reduces overall length
- Rounded corners prevent cutting
- Annealed steel for maximum strength
- Precision swaged mechanical crimp
- Standard size set screws
- AGMA Class 2 bore tolerance: $-.000 + .002$

Flexible Element:

- Maximum flexibility because of unique design
- Polyurethane is durable, flexible, cut-and-wear resistant
- Greater radius for added strength
- Full wrap-around design stays securely in hub
- Non-standard bore combinations available...inquire for price and availability

Illustration	Dimensions					Set Screw	Capacity (in.-lbs.)	Maximum Angular Misalignment	Max. Lateral Misalignment (inch)	Part No.
	A*	B	C	D	E					
1	1-1/8	1-1/8	11/16	1/16	.188	#6-32	3	10°	3/32	T21-3
					.312					T21-4
					.375					T21-5
										T21-6
2	1-7/8	1-3/4	1	3/8	.250	#10-24	12	15°	1/8	T22-4
					.312					T22-5
					.375					T22-6
					.438					T22-7
					.500					T22-8
2	2-1/8	2-1/8	1-1/8	7/16	.375	#1/4-20	28	15°	3/16	T23-6
					.438					T23-7
					.500					T23-8
					.562					T23-9
					.625					T23-10
2	2-1/8	2-3/8	1-1/8	3/8	.500	#1/4-20	40	15°	1/8	T24-8
					.562					T24-9
					.625					T24-10

*Dimensions at widest point

BORE REDUCERS

Inch And Metric

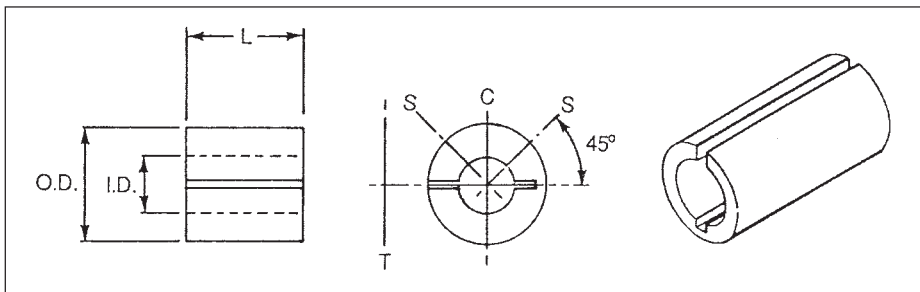

Material: Aluminum

Inch to inch and inch to metric bore reducers adapt a coupling, clutch, pulley and other bores to a number of shaft diameters when fitted to a pin hub (set screw) or split hubs.

Grip relies on adequate contact area between the shaft and reducer.

Release of residual stresses after slitting may result in slight springing of the material, — this can be corrected by finger pressure.

For optimum fastening install bore reducers as shown:

“S” = Two Set Screw Position

“C” = One Set Screw

“T” = Tangential Screw In Clamp Hub

Inch to Inch Reduction			
OD +.0005 -.001	ID +.001 -.000	L ±.010	Part No.
.250	.125	3/8	R-04-02-375
.250	.187	3/8	R-04-03-375
.375	.250	1/2	R-06-04-500
.375	.3125	1/2	R-06-05-500
.500	.375	1/2	R-08-06-750

Inch to Metric Reduction			
OD +.0005 -.001	ID +.025 -.000 (mm)	L ±.25 (mm)	Part No.
.250	5	8 (.312)	MR-04-05-08
.375	6	11 (.433)	MR-06-06-11
.375	8	12 (.472)	MR-06-08-12
.500	10	16 (.625)	MR-08-10-16
.625	12	16 (.625)	MR-10-12-12

Bore Reducers With Thicker Walls May Have Slot In Opposite Wall For Proper Flexibility.

Sold & Serviced By:

ELECTROMATE

Toll Free Phone (877) SERV098

Toll Free Fax (877) SERV099

www.electromate.com

sales@electromate.com

PRECISION UNIVERSAL JOINTS

1/8", 3/16", and 1/4" Bores and 3, 4, 6 mm Bores

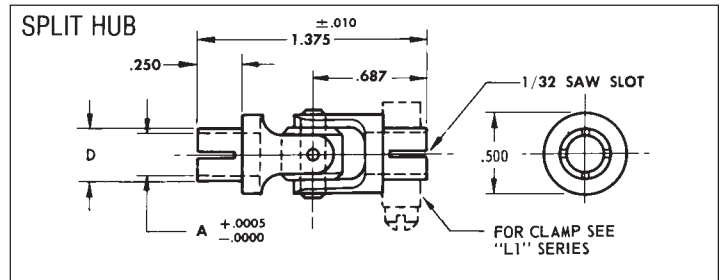
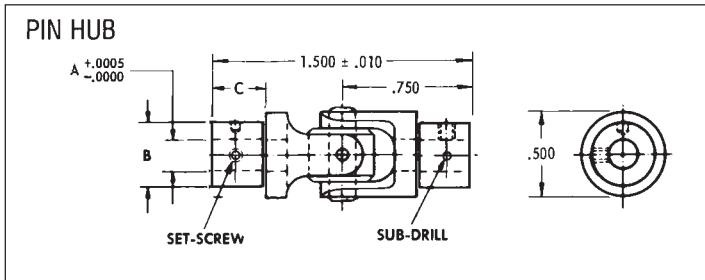

Material: 303 Stainless Steel

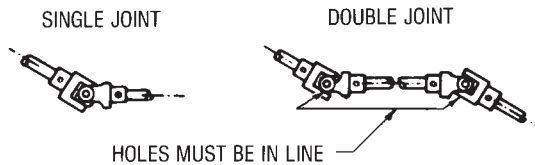

Inch Bores Toler. +.0005 - .0000	Shaft Size	A	B	C	D	Set Screw	Clamp No. (Ref.)	Pin Hub Part No.	Split Hub Part No.
3/16	.1873	.375	.312	.250	#4-40	L1-5	BC-2	BC-11	
1/4	.2498	.500	—	.312	#6-32	L1-6	BC-3	BC-12	
Dimensions below are in millimeters.									
Metric Bores Toler. +.013 - .000	3	2.995	7.92	7.92	4.78	L1-4		MUJ3-1	MUJ4-1
	4	3.995	9.52	7.92	6.35	L1-5		MUJ3-2	MUJ4-2
	6	5.995	12.70	—	7.92	L1-6		MUJ3-3	MUJ4-3

Universal joints will operate at angles up to 30°. For most efficient operation, operate at a maximum angle of 10°. Lubrication required.
Maximum speed: 300 RPM.

MOLDED UNIVERSAL JOINTS

1/8", 3/16", and 1/4" Bores and 3, 4, 6 mm Bores

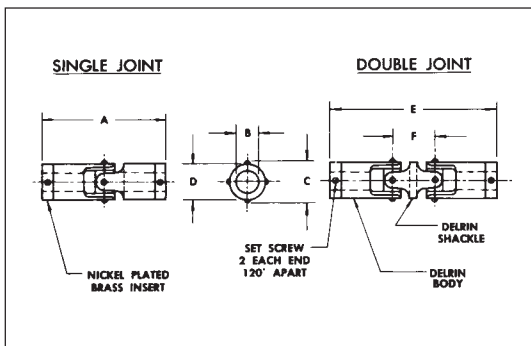

Inch Bores Toler. +.001 - .000	Type	B	A	C	D	E	F	Set Screw	Part No.
3/16	1-31/64	7/16	3/8	—	—	#4-40	BC-22		
3/16 to 1/4	1-13/16	9/16	1/2	—	—	#4-40 #6-32	BC-24		
1/4	1-13/16	9/16	1/2	—	—	#6-32	BC-25		
Double Joint	3/16	—	7/16	3/8	2	33/64	#4-40	BC-32	
	1/4	—	9/16	1/2	2-7/16	5/8	#6-32	BC-35	
Dimensions below are in millimeters.									
Metric Bores Toler. +.025 - .000	Single Joint	3 to 3	37.70	11.11	9.52			M2X.4	MUJ2-1
		3 to 4	37.70	11.11	9.52			M2X.4	MUJ2-2
		4 to 4	37.70	11.11	9.52			M2X.4	MUJ2-3
		4 to 6	46.04	14.29	12.70			M2X.4	MUJ2-4
		6 to 6	46.04	14.29	12.70			M3X.5	MUJ2-5
	Double Joint	3 to 3		11.11	9.52	50.8	13.10	M2X.4	MUJ2-6
		3 to 4		11.11	9.52	50.8	13.10	M2X.4	MUJ2-7
		4 to 4		11.11	9.52	50.8	13.10	M2X.4	MUJ2-8
		4 to 6		14.29	12.70	61.9	15.88	M2X.4	MUJ2-9
		6 to 6		14.29	12.70	61.9	15.88	M3X.5	MUJ2-10

Sold & Serviced By:

 Toll Free Phone (877) SERV098
 Toll Free Fax (877) SERV099
www.electromate.com
sales@electromate.com

C		Capac. Oz-In.*	
In.	mm	Cont.	Manual
7/16	(11.11)	25	50
9/16	(14.29)	85	170

*Based on 3.6° max. allowable deflection for continuous operation and 7° for manual operation. Double joints have one-half of these capacities.

Max. shaft angles are 10° for 2000 rpm, 15° for 1500 rpm, 20° for 1000 rpm and 30° for 500 rpm.