



**THOMSON™**

# T-Series Ball Profile Rail

**TECHNICAL BULLETIN**

Sold & Serviced By:

 **ELECTROMATE**

Toll Free Phone (877) SERV098

Toll Free Fax (877) SERV099

[www.electromate.com](http://www.electromate.com)

[sales@electromate.com](mailto:sales@electromate.com)

 **DANAHER**  
**MOTION**

*Helping you build a better machine, **faster.***

## T-Series Profile Rail

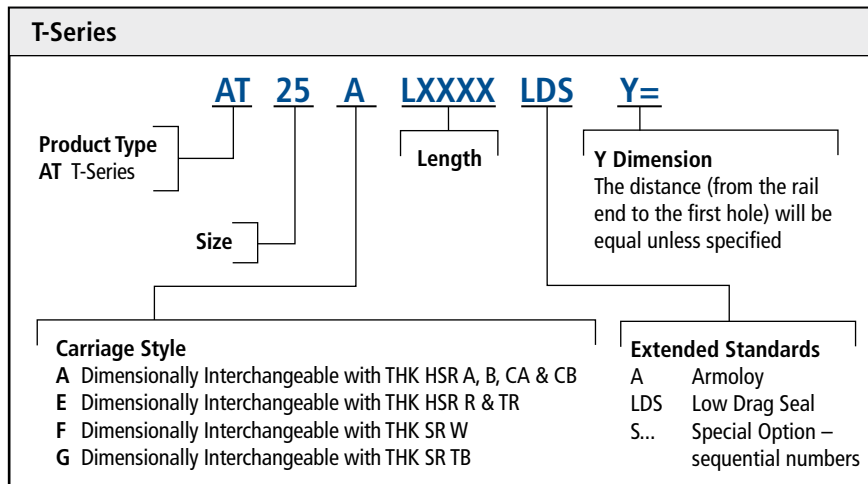
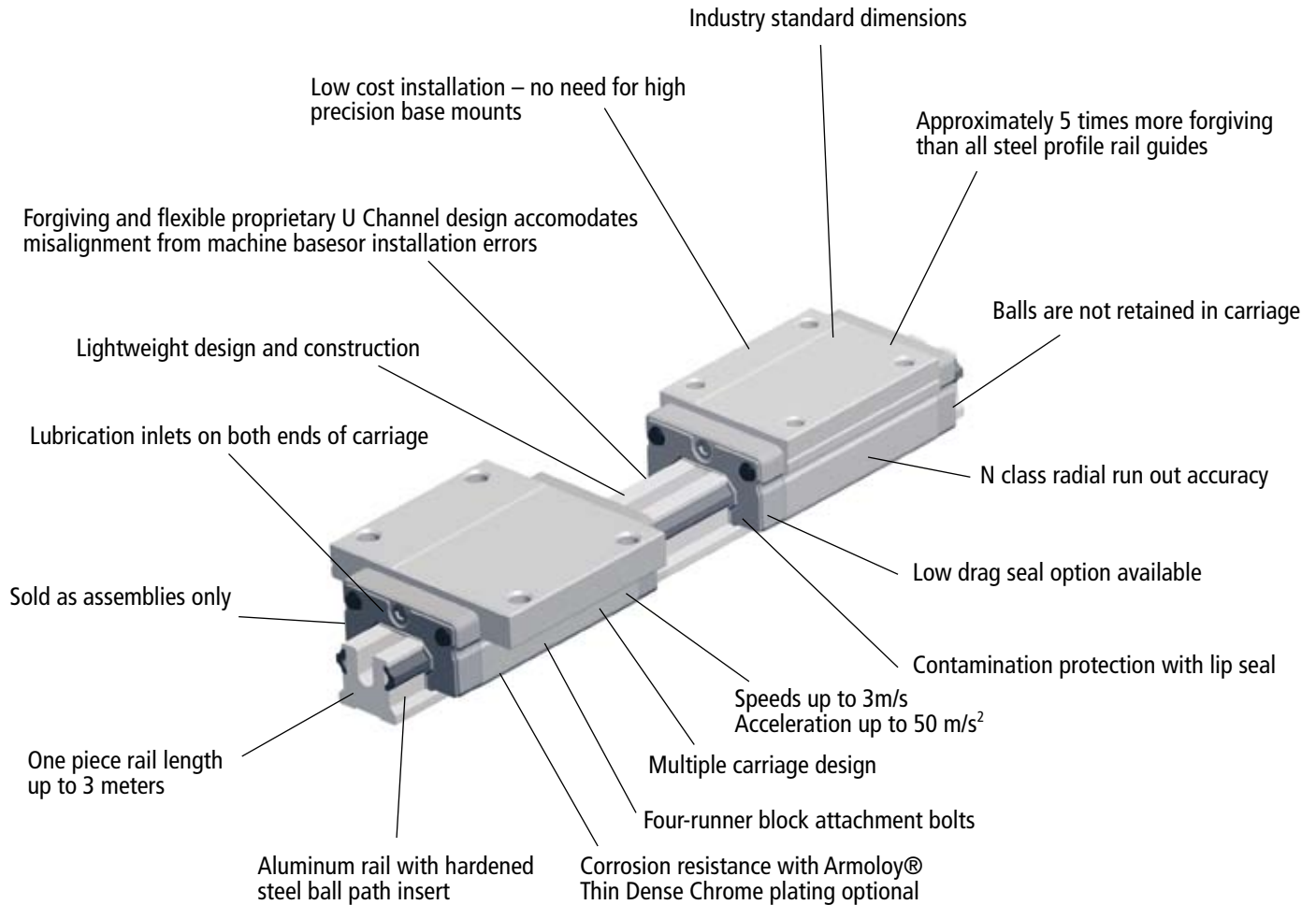

Note: 1. Sold as assemblies only  
2. Carriages are dimensionally matched to rails during assembly

## T-Series Ball Profile Rail

### Features

The Thomson T-Series Ball Profile Rail is lightweight, highly flexible and forgiving — an ideal choice for poor misalignment. It has a low cost of installation and industry standard dimensions for easy replacement. It is a lightweight and forgiving alternative to all-steel profile rail.

### Materials

The Thomson T-Series Ball Profile Rail carriage and rail is produced from high quality aircraft aluminum alloy. The carriage has hardened steel load bearing plates. The rail has a custom ball path insert made of hardened steel. Stringent quality controls are in place to ensure consistency of steel from the source, allowing us to ensure that we deliver the highest quality product.

### Lightweight

The aluminum carriage and rail dramatically reduces the total weight of the assembly making Thomson T-Series an ideal choice for applications requiring reduced weight inertia such as airplanes, ships, automobiles, etc.

### Accuracy

As a result of its high flexibility to misalignment errors, the T-Series Ball Profile Rail is available in an N class radial run out only.

### Forgiving to Misalignment

The Thomson T-Series propriety “U” channel construction allows the rail to “flex” to accommodate poor machine bases or misalignment errors.

### Low Cost

The Thomson T-Series can be mounted direct to non-machined bases without sacrificing total operational efficiency or the need for special tools or gauges to ensure proper rail and base straightness. By eliminating the costly machined base and special tools the installation time or machine build time can be cut in half, saving valuable time and money.

### Drop-in Replacement

The Thomson T-Series is designed to industry standard dimensions and rail hole patterns. This means it can be used as a drop-in replacement for any conventional all steel profile linear guide in the market today.

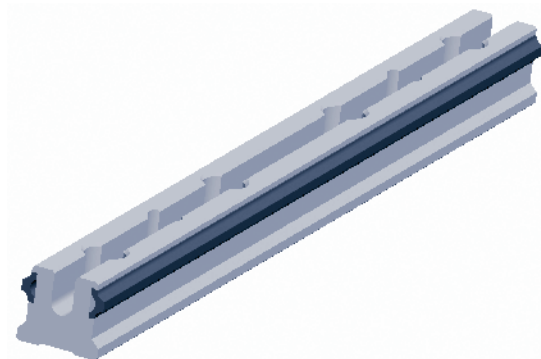
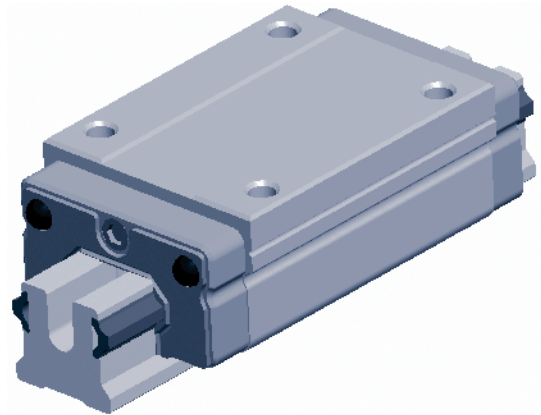

For more information, or to place an order, please contact your local authorized Thomson™ distributor or Danaher Motion at 1-540-633-3400, Fax: 1-540-633-4162, or E-mail at [proflerail@DanaherMotion.com](mailto:proflerail@DanaherMotion.com).

Sold & Serviced By:



Toll Free Phone (877) SERV098  
Toll Free Fax (877) SERV099  
[www.electromate.com](http://www.electromate.com)  
[sales@electromate.com](mailto:sales@electromate.com)

## T-Series Carriage Styles

### Standard Carriage Style A

Sizes 20, 25, 35  
Dimensionally interchangeable to THK  
HSR A, B, CA, CB and Thomson 511 A

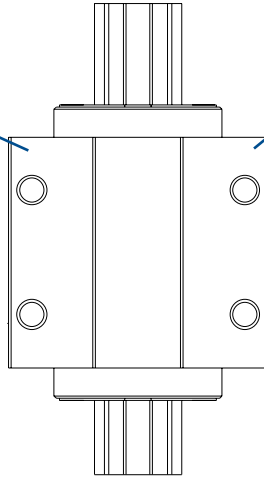
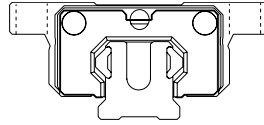

### Standard Short Hole Spacing Style G

Sizes 20, 25, 35  
Dimensionally interchangeable to THK SR TB

### Narrow Carriage Style E

Sizes 20, 25, 35  
Dimensionally interchangeable to THK  
HSR R and TR and Thomson 511 E

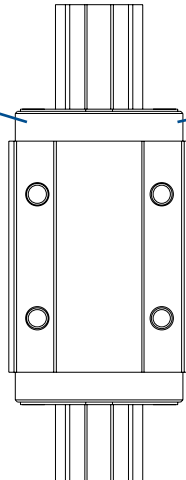
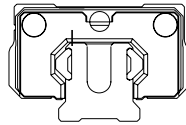

### Narrow High Style F

Sizes 20, 25, 35  
Dimensionally interchangeable to THK SR W

For more information, or to place an order, please contact your local authorized Thomson™ distributor or Danaher Motion at 1-540-633-3400, Fax: 1-540-633-4162, or E-mail at [profilerrail@DanaherMotion.com](mailto:profilerrail@DanaherMotion.com).

Sold & Serviced By:



Toll Free Phone (877) SERV098  
Toll Free Fax (877) SERV099  
[www.electromate.com](http://www.electromate.com)  
[sales@electromate.com](mailto:sales@electromate.com)

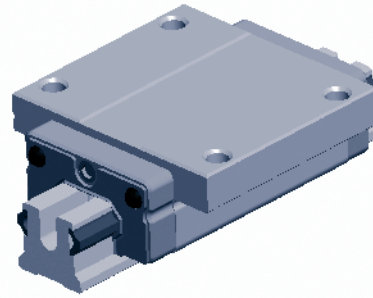

**T-Series  
Style A and G**

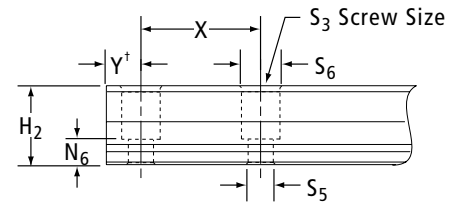
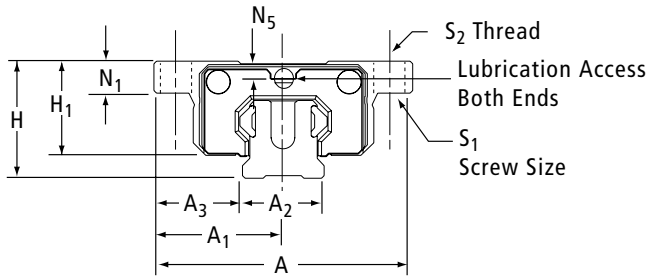

†- Will be equal on both ends, unless otherwise specified.

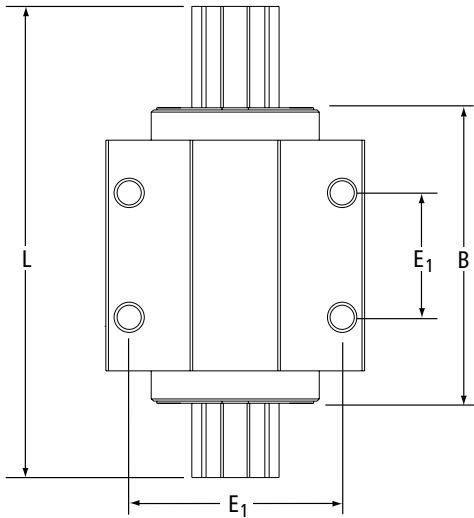

**Supplied  
Lubrication Fittings**

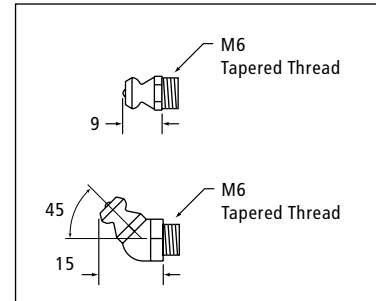

**T-Series Profile Rail Standard High "A" Style**

Size	A	A1	A2	A3	H	H1	H2	B	E1	E2	S1	S2	S3	S5	S6	N1	N5	N6	X	L <sub>max</sub>
20	63	31.5	20	21.5	30	25	18	76	53	40	M5	M6	M5	5.8	9.5	10	6.25	7.5	60	3000
25	70	35	23	23.5	36	29.5	22	88	57	45	M6	M8	M6	7	10.7	12	8	10	60	3000
35	100	50	34	33	48	40	29	117	82	62	M8	M10	M8	9	14	15.26	6.6	11	80	3000

All dimensions in mm unless shown otherwise

**T-Series Profile Rail Standard "G" Style**

Size	A	A1	A2	A3	H	H1	H2	B	E1	E2	S1	S2	S3	S5	S6	N1	N5	N6	X	L <sub>max</sub>
20	59	29.5	20	19.5	28	23	18	76	49	32	M5	M6	M5	5.8	9.5	8	4.25	7.5	60	3000
25	73	36.5	23	25	33	26.5	22	88	60	35	M6	M8	M6	7	10.7	9	5	10	60	3000
35	100	50	34	33	48	40	29	117	82	50	M8	M10	M8	9	14	15.26	6.6	11	80	3000

For more information, or to place an order, please contact your local authorized Thomson™ distributor or Danaher Motion at 1-540-633-3400, Fax: 1-540-633-4162, or E-mail at [profilerail@DanaherMotion.com](mailto:profilerail@DanaherMotion.com).

Sold & Serviced By:



Toll Free Phone (877) SERV098  
Toll Free Fax (877) SERV099  
[www.electromate.com](http://www.electromate.com)  
[sales@electromate.com](mailto:sales@electromate.com)

# T-Series

## Style A and G

### Dynamic Load Rating

C = Dynamic load rating

The dynamic load rating is based upon a 100 km travel life. In order to compare with bearings rated for 50 km, divide the dynamic rating of the bearing rated for 50 km by 1.26.

### Static Load Capacity

C<sub>0</sub> = Static load capacity

The static load capacity is the maximum radial load that should be applied to the bearing while there is no relative motion between the carriage and rail.

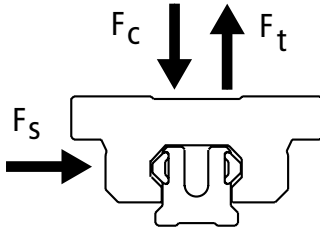

Size	Style	Load Ratings N (lbf)		Mass Carriage kg	Rail kg/m
		C (@100km)	C <sub>0</sub>		
20	A G	9000 (2025)	11000 (2475)	0.22	0.79
25	A G	13000 (2925)	15000 (3375)	0.30	1.06
35	A G	25000 (5620)	28000 (6295)	0.74	2.27

	Dynamic Load Rating	Load Limit
F <sub>c</sub>	C	C
F <sub>t</sub>	C	0.6C
F <sub>s</sub>	C	0.6C

### Bearing Travel Life Calculation

$$L = (C/F)^3 \times 100 \text{ km}$$

where:

L = travel life, km

C = dynamic load rating, N

F = applied dynamic load, N

### Operating Parameters

Maximum Velocity = 3 m/s

Maximum Acceleration = 50 m/s<sup>2</sup>

Maximum Temperature = 80°C

For more information, or to place an order, please contact your local authorized Thomson™ distributor or Danaher Motion at 1-540-633-3400, Fax: 1-540-633-4162, or E-mail at [profilerrail@DanaherMotion.com](mailto:profilerrail@DanaherMotion.com).

Sold & Serviced By:



Toll Free Phone (877) SERV098  
 Toll Free Fax (877) SERV099  
[www.electromate.com](http://www.electromate.com)  
[sales@electromate.com](mailto:sales@electromate.com)

**T-Series  
Style E and F**

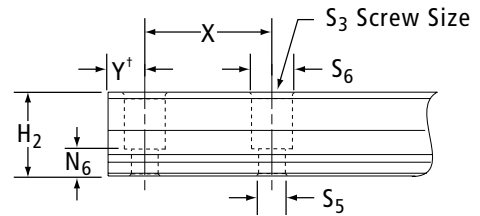
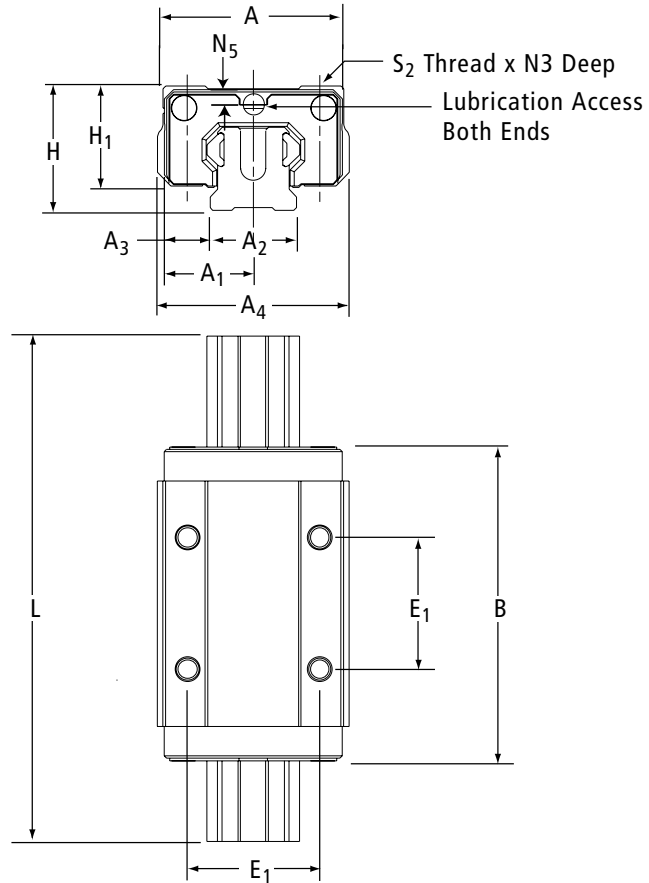
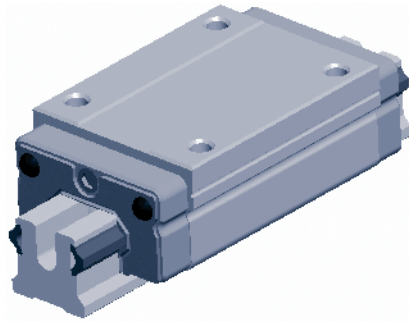

†- Will be equal on both ends, unless otherwise specified.

**Supplied  
Lubrication Fittings**

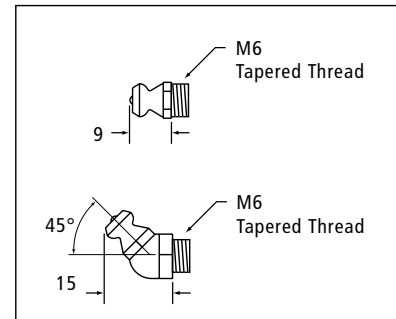

**T-Series Profile Rail Narrow "E" Style**

Size	A	A1	A2	A3	A4	H	H1	H2	B	E1	E2	S2	S3	S5	S6	N3	N5	N6	X	L <sub>max</sub>
20	44	22	20	12	41.5	30	25	18	76	32	36	M5	M5	5.8	9.5	6	6.25	7.5	60	3000
25	48	24	23	12.5	50.9	40	33.5	22	88	35	35	M6	M6	7	10.7	8	12	10	60	3000
35	70	35	34	18	68.0	55	47	29	117	50	50	M8	M8	9	14	12	13.6	11	80	3000

All dimensions in mm unless shown otherwise

**T-Series Profile Rail Narrow High "F" Style**

Size	A	A1	A2	A3	A4	H	H1	H2	B	E1	E2	S2	S3	S5	S6	N3	N5	N6	X	L <sub>max</sub>
20	42	21	20	11	41.5	28	23	18	76	32	32	M5	M5	5.8	9.5	6	4.25	7.5	60	3000
25	48	24	23	12.5	51.0	33	26.5	22	88	35	35	M6	M6	7	10.7	8	5	10	60	3000
35	70	35	34	18	68.0	48	40	29	117	50	50	M8	M8	9	14	12	6.6	11	80	3000

All dimensions in mm unless shown otherwise

For more information, or to place an order, please contact your local authorized Thomson™ distributor or Danaher Motion at 1-540-633-3400, Fax: 1-540-633-4162, or E-mail at [profilerail@DanaherMotion.com](mailto:profilerail@DanaherMotion.com).

Sold & Serviced By:



Toll Free Phone (877) SERV098  
Toll Free Fax (877) SERV099  
[www.electromate.com](http://www.electromate.com)  
[sales@electromate.com](mailto:sales@electromate.com)

# T-Series

## Style E and F

### Dynamic Load Rating

$C$  = Dynamic load rating

The dynamic load rating is based upon a 100 km travel life. In order to compare with bearings rated for 50 km, divide the dynamic rating of the bearing rated for 50 km by 1.26.

### Static Load Capacity

$C_0$  = Static load capacity

The static load capacity is the maximum radial load that should be applied to the bearing while there is no relative motion between the carriage and rail.

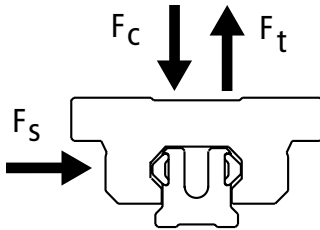

Size	Style	Load Ratings N (lbf)		Mass	
		$C$ (@100km)	$C_0$	Carriage kg	Rail kg/m
20	A G	9000 (2025)	11000 (2475)	0.22	0.79
25	A G	13000 (2925)	15000 (3375)	0.30	1.06
35	A G	25000 (5620)	28000 (6295)	0.74	2.27

	Dynamic Load Rating	Load Limit
$F_c$	$C$	$C$
$F_t$	$C$	$0.6C$
$F_s$	$C$	$0.6C$

### Bearing Travel Life Calculation

$$L = (C/F)^3 \times 100 \text{ km}$$

where:

$L$  = travel life, km

$C$  = dynamic load rating, N

$F$  = applied dynamic load, N

### Operating Parameters

Maximum Velocity = 3 m/s

Maximum Acceleration = 50 m/s<sup>2</sup>

Maximum Temperature = 80°C

For more information, or to place an order, please contact your local authorized Thomson™ distributor or Danaher Motion at 1-540-633-3400, Fax: 1-540-633-4162, or E-mail at [profilerrail@DanaherMotion.com](mailto:profilerrail@DanaherMotion.com).

Sold & Serviced By:



Toll Free Phone (877) SERV098  
 Toll Free Fax (877) SERV099  
[www.electromate.com](http://www.electromate.com)  
[sales@electromate.com](mailto:sales@electromate.com)