



FINE CYCLO E CYCLO

Zero Backlash Precision Gearboxes

Sold & Serviced By:



Toll Free Phone (877) SERV098

www.electromate.com

sales@electromate.com

Copyright Sumitomo (SHI) Cyclo Drive Germany GmbH 2021.

All rights reserved. Copying, including extracts, is only permitted with our approval.

The information in this catalogue has been checked for correctness with extreme care. Nevertheless, we cannot accept any liability for the correctness or accuracy of this information.

We reserve the right to make modifications.

Fine Cyclo series

Table of contents	Page	Page
1 The Fine Cyclo reducer	2	9 T-Series 127
1.1 Operating principle - Series A, DA, and C	4	9.1 Torques according to output speeds 128
1.2 Operating principle Series UA and T	5	9.2 Torques according to input speeds 130
1.3 Operating principle of Series ECY	6	9.3 Stiffness and Lost Motion 132
1.4 Speed ratio and rotation direction - Series A, D, DA, and C	7	9.4 No-load running torque NLRT 132
1.5 Speed ratio and direction of rotation Series T and UA	7	9.5 Breakaway torque 133
1.6 Speed ratio and rotation direction - Series ECY	8	9.6 Efficiency 134
1.7 Features and advantages	9	9.7 Main bearing 135
1.8 Application Examples	9	9.8 Assembly specifications and tolerances 136
		9.9 Dimensioned drawings 140
2 Nomenclature	10	10 ECY-Series 147
2.1 Fine Cyclo	10	10.1 Standard specifications 148
2.2 ECY series	10	10.2 Features 148
3 Gearbox selection	11	10.3 Flow chart and equation of selection 150
3.1 Reduction ratio and acceleration torque	11	10.4 Rating 152
3.2 Max. bending moment on the output flange	11	10.5 Stiffness 153
3.3 Max. hollow shaft diameter	11	10.6 No-load running torque NLRT 153
3.4 Reduction ratio and outer diameter	12	10.7 Breakaway torque on the output shaft 154
3.5 Torques and speeds	16	10.8 Efficiency 154
3.6 Flow chart and equation of selection	18	10.9 Main bearings 155
4 Description of technical specifications for cycloidal gearboxes	22	10.10 Bearing loads 157
		10.11 Notes on installation 159
		10.12 Dimensioned drawings 162
5 A-Series	26	11 Appendix 164
5.1 Torques according to output speeds	28	
5.2 Torques according to input speeds	30	
5.3 Stiffness and Lost Motion	32	
5.4 No-load running torque NLRT	33	
5.5 Breakaway torque	33	
5.6 Efficiency	34	
5.7 Bearing loads	35	
5.8 Lubrication	40	
5.9 Model FC-A	41	
5.10 Model F1C-A	47	
5.11 Model F2C(F)-A	52	
5.12 Model F3C-A	58	
6 DA-Series	63	
6.1 Torques according to output speeds	64	
6.2 Torques according to input speeds	66	
6.3 Stiffness and Lost Motion	68	
6.4 No-load running torque NLRT	68	
6.5 Breakaway torque	69	
6.6 Efficiency	70	
6.7 Bearing loads	71	
6.8 Assembly specifications and tolerances	75	
7 C-Series	85	
7.1 Torques according to output speeds	86	
7.2 Torques according to input speeds	88	
7.3 Stiffness and Lost Motion	90	
7.4 No-load running torque NLRT	91	
7.5 Breakaway torque	91	
7.6 Efficiency	92	
7.7 Bearing loads	93	
7.8 Assembly specifications and tolerances	97	
7.9 Dimensioned drawings	100	
8 UA-Series	103	
8.1 Torques according to output speeds	104	
8.2 Torques according to input speeds	108	
8.3 Stiffness and Lost Motion	112	
8.4 No-load running torque NLRT	112	
8.5 Breakaway torque	113	
8.6 Efficiency	114	
8.7 Main bearing	115	
8.8 Assembly specifications and tolerances	117	
8.9 Dimensioned drawings	120	

Sold & Serviced By:



Toll Free Phone (877) SERV098

www.electromate.com

sales@electromate.com

1 The Fine Cyclo reducer

Construction A-Series

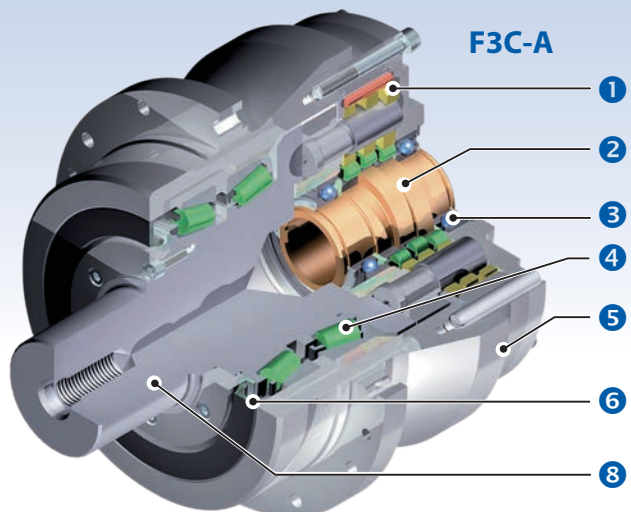
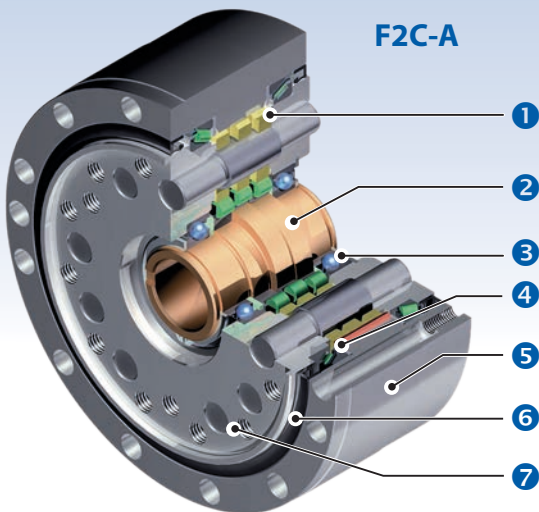
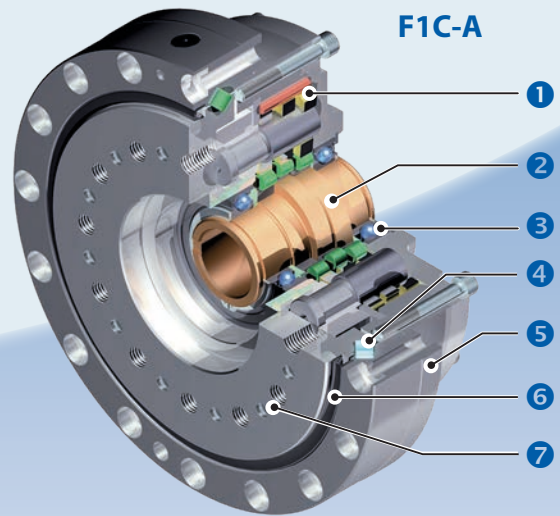
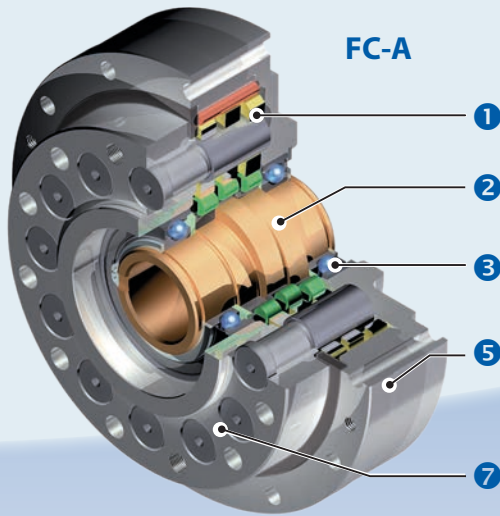

Construction DA-Series

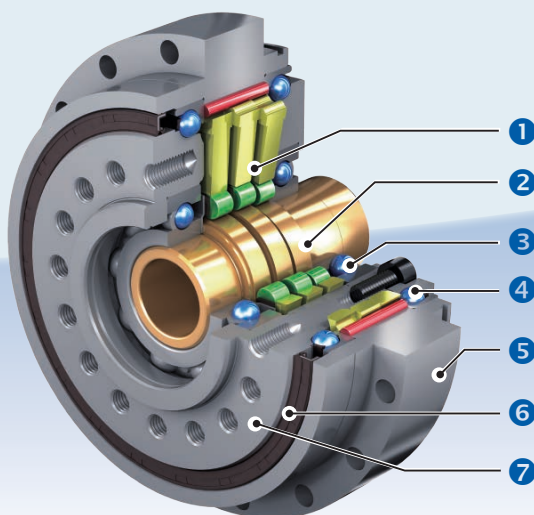

- 1 Cycloid disc
- 2 Eccentric input shaft
- 3 Input shaft bearing
- 4 Main Bearings
- 5 Ring gear (housing)
- 6 Oil seal output side
- 7 Output flange
- 8 Output shaft

Construction C-Series

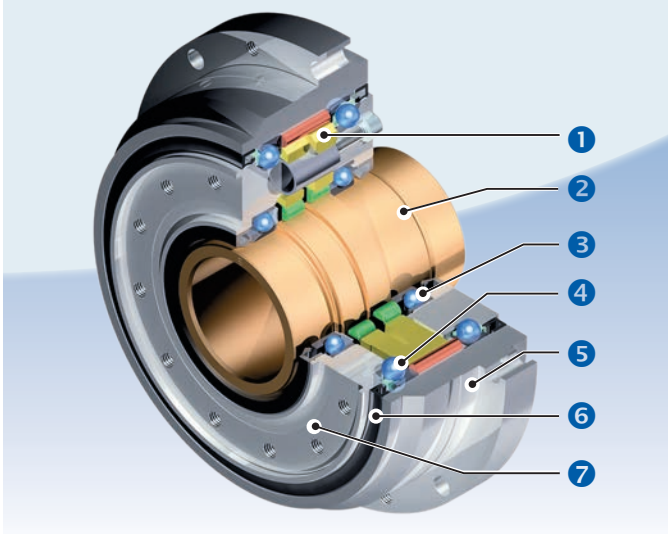

Construction UA-Series

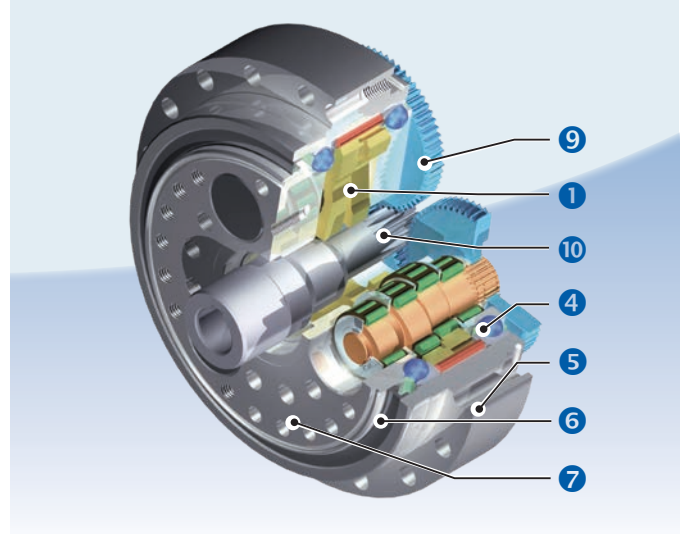

Construction T-Series

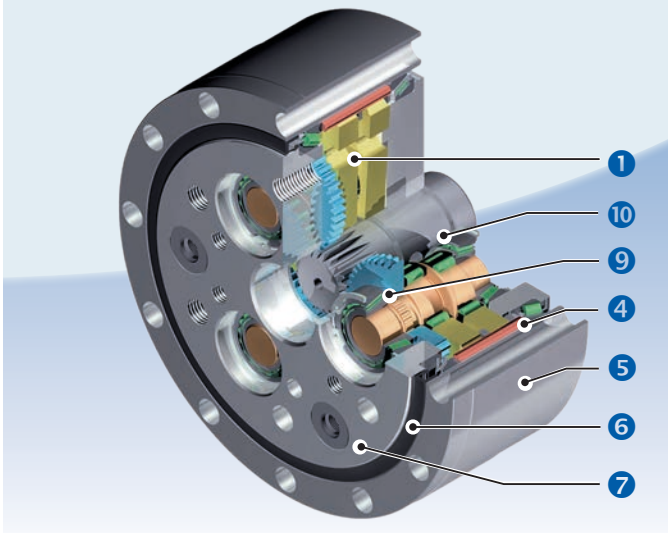

- ① Cycloid disc
- ② Eccentric input shaft
- ③ Input shaft bearing
- ④ Main Bearings
- ⑤ Ring gear (housing)
- ⑥ Oil seal output side
- ⑦ Output flange
- ⑧ Output shaft
- ⑨ planetary gears
- ⑩ input shaft with spur gear

Construction ECY-Series

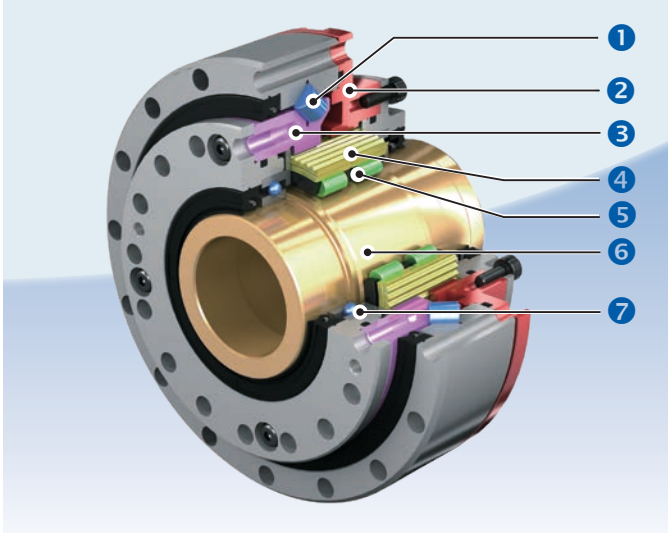

- ① Main bearing (cross roller bearing)
- ② Ring gear housing
- ③ Output ring gear housing
- ④ Cycloid spline
- ⑤ Eccentric bearing
- ⑥ Eccentric input shaft
- ⑦ Input shaft bearing

Sold & Serviced By:



Toll Free Phone (877) SERV098
www.electromate.com
sales@electromate.com

1.1 Operating principle - Series A, DA, and C

The gearbox of the Fine Cyclo series is fundamentally different in principle and mechanism from the helical gearing mechanism of competitors' gear motors. The unique reduction gearbox is an ingenious combination of the following two mechanisms:

- A planetary gear and a fixed internal sun gear (hollow gear). On the Fine Cyclo the planetary gear has cycloidal cam motion (cycloid disc) and the fixed sun gear has a circular arrangement of ring gear pins. The fixed sun gear has one or two "teeth" more than the "planetary gear" (cycloid disc).
- A spline for constant speed.

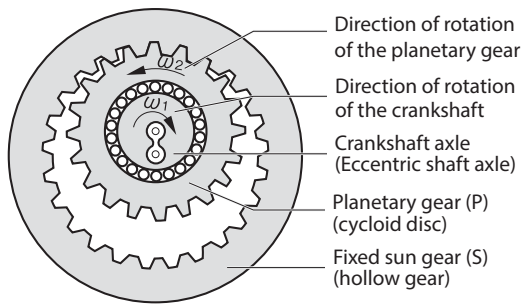

Fig. 1 Principle of the internal planetary gearbox

In Equation 1, below, P identifies the number of the planetary gear teeth, S that of the sun gear, and ω2 the angular velocity of the planetary gear about its own axis (see Fig. 1). The speed ratio of ω2 to ω1 is represented as follows:

$$\text{Equation 1 } \frac{\omega_2}{\omega_1} = 1 - \frac{S}{P} = -\frac{S-P}{P}$$

The highest velocity ratio is obtained with S greater than P by one or two in this equation.

In other words, if S-P=1 is applied to Equation 1, the velocity ratio may be calculated using the following equation:

$$\text{Equation 2 } \frac{\omega_2}{\omega_1} = -\frac{1}{P}$$

If, on the other hand, S-P=2 is applied to Equation 1, the velocity ratio may be calculated using the following equation:

$$\text{Equation 3 } \frac{\omega_2}{\omega_1} = -\frac{2}{P}$$

As the crankshaft rotates at the angular velocity ω1 around the axis of the sun gear, the planetary gear also rotates at the angular velocity:

$$-\frac{1\omega_1}{P} \text{ or } -\frac{2\omega_1}{P}$$

P indicates the number of teeth of the planetary gear and the symbol indicates that the planetary gear rotates in a reverse direction to that of the crankshaft (eccentric).

As shown in Fig. 2, the teeth (pins) arranged in a circular formation for the sun gear and the epitrochoid teeth for the planetary gear on the Fine Cyclo are adapted so that the gearings do not interfere with one another.

The rotation of the planetary gear around its own axis is caused by a constant speed internal gearing mechanism as shown (see Fig. 4).

In this mechanism, shown in Fig. 4 the pins of the output shaft are evenly spaced on a circle that is concentric to the axis of the sun gear. The pins transmit the rotation of the planetary gear by rolling internally around the circumference of the bores of each planetary gear or cycloid disc.

The diameter of the bores minus the diameter of the slow speed shaft pins is equal to twice the eccentricity value of the crankshaft (eccentric).

This mechanism smoothly transmits only the rotation of the planetary gear around its own axis to the output shaft.

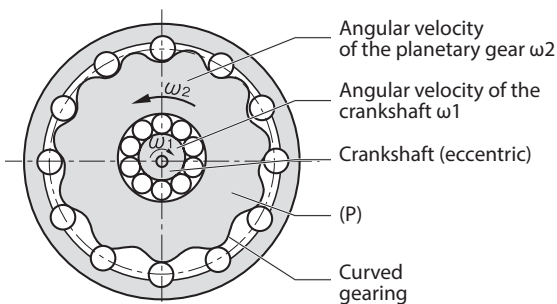

Fig. 2 Epitrochoidal planetary gear, circular arrangement of ring gear pins (PIN) combination

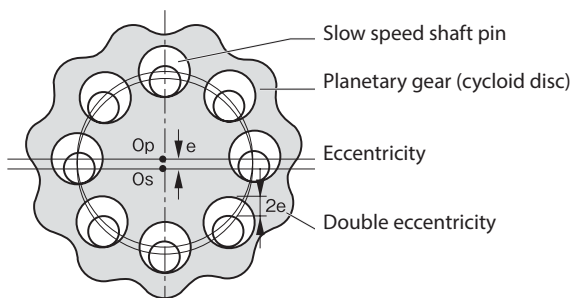

Fig. 3 Internal gearing for constant speed

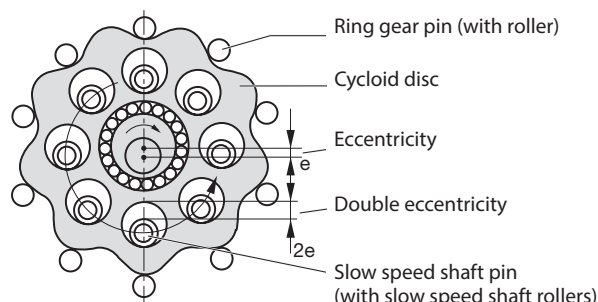

Fig. 4 Planetary sun gear combination and internal gearing for constant speed

Sold & Serviced By:



Toll Free Phone (877) SERV098

www.electromate.com
sales@electromate.com

1.2 Operating principle Series UA and T

The Series UA and T gearboxes are double-stage and differ from the single-stage series by having 3 eccentric discs (cycloid disc), driven by the input shaft with spur teeth. The cycloid discs are driven via 3 eccentric shafts and not directly by one eccentric input shaft. The pins and the eccentric shafts in the output shaft are evenly spaced on a circle, which is concentric with the axis of the sun gear. The pins transmit the rotation of the planetary gear by rolling internally around the circumference of the bores of each planetary gear or cycloid disc.

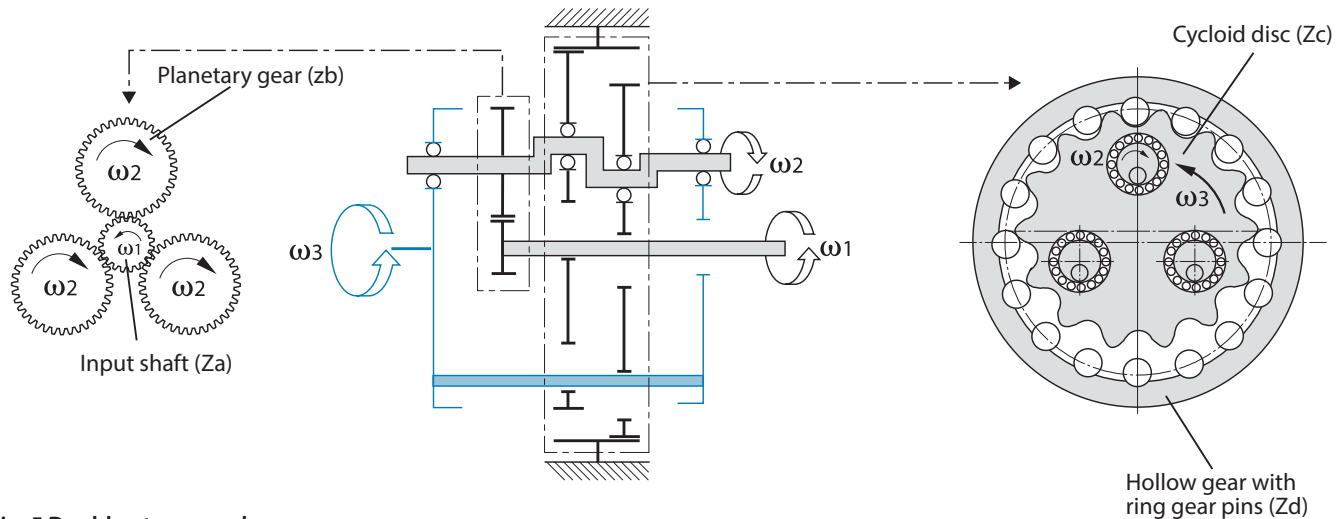

Fig. 5 Double-stage gearbox

If the input shaft rotates with a speed ω_1 , then the angular velocity of the planetary gear around its own axis is ω_2 .

If the eccentric shaft rotates with a rotational speed ω_2 and the hollow gear is fixed, then the angular velocity of the cycloid discs about their own axis is ω_3 . Z is the number of teeth or the number of curve traces or ring gear pins.

$$\text{Equation 1 } \omega_2 = \frac{Z_a}{Z_b} (\omega_3 - \omega_1) + \omega_3$$

$$\text{Equation 2 } \omega_3 = \left(1 - \frac{Z_d}{Z_c}\right) \cdot \omega_2$$

Partial reduction ratio when the angular velocity of the eccentric shaft gear around the input shaft is equal to 0:

$$\text{Equation 3 } i_1 = \frac{Z_b}{Z_a}$$

Partial reduction ratio of the trochoid gearing:

$$\text{Equation 4 } i_2 = \frac{Z_c}{Z_c - Z_d}$$

$$\text{Equation 5 } i = 1 + i_1 \cdot (1 - i_2)$$

$$\text{Total reduction ratio } i = \omega_1 / \omega_3$$

Sold & Serviced By:

 **ELECTROMATE**

Toll Free Phone (877) SERV098
www.electromate.com
sales@electromate.com

1.3 Operating principle of Series ECY

Every ECY series model always comprises four components.

- The eccentric bearing deforms the planetary gear into an elliptical shape.
- The main axis of the cycloid spline, which now has an elliptical shape, engages with the ring gear housing and the output ring gear housing.
- If the housing containing the internal gear is actually stationary and the eccentric bearing rotates clockwise, the cycloid spline rotates anti-clockwise by exactly the difference in the number of teeth and is elastically deformed in the process.
- This rotation is transferred via the output ring gear housing.

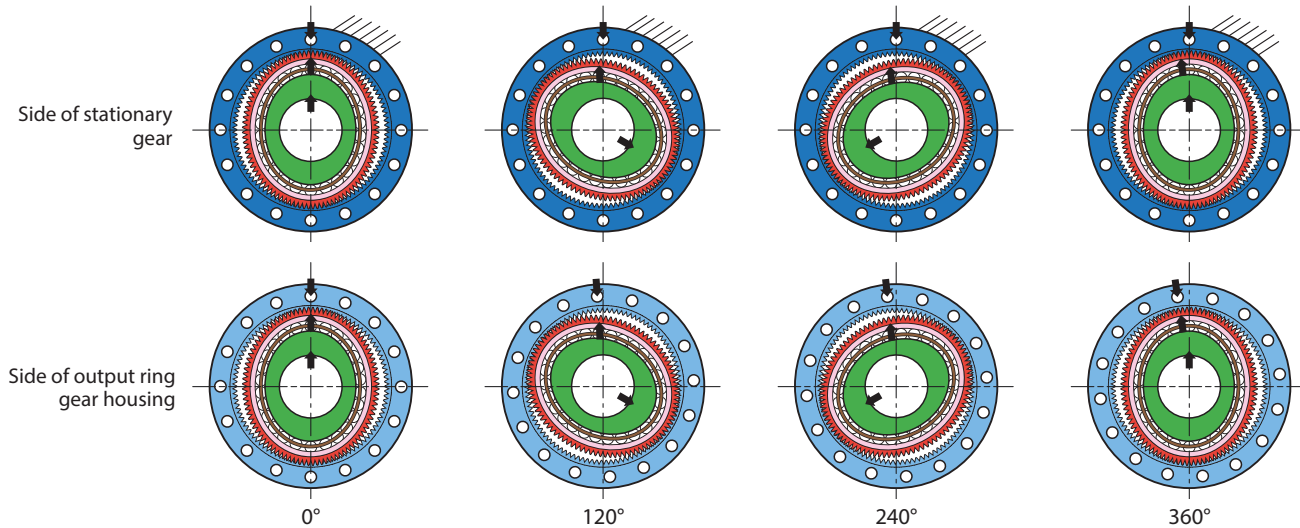
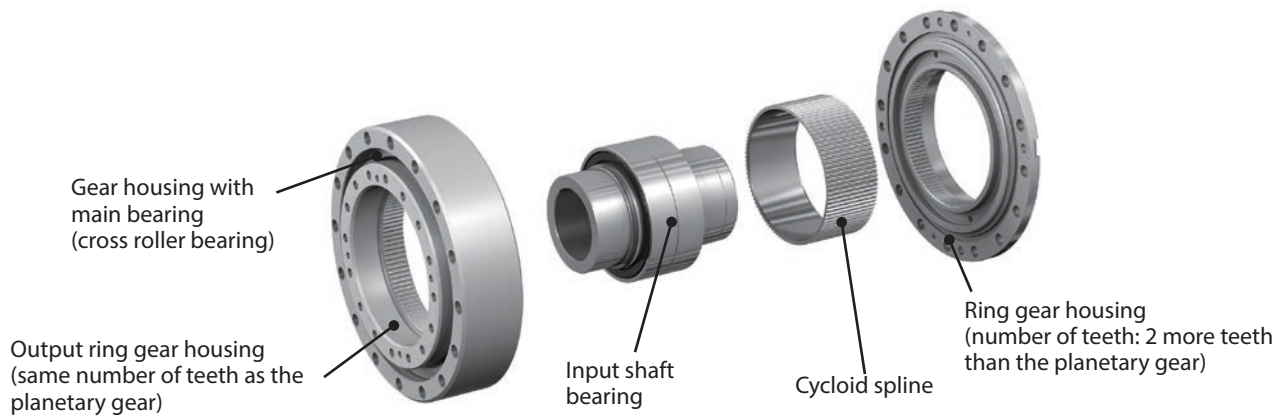

Sold & Serviced By:



Toll Free Phone (877) SERV098

www.electromate.com

sales@electromate.com

1.4 Speed ratio and rotation direction - Series A, D, DA, and C

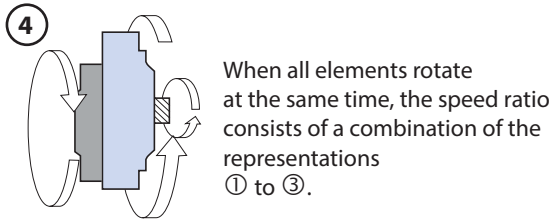
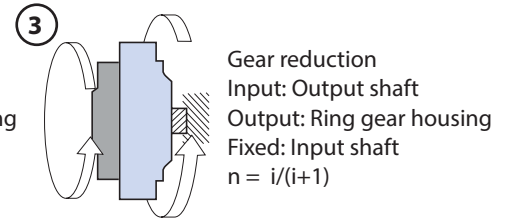
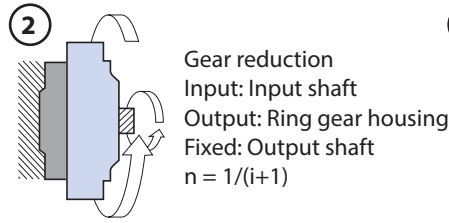
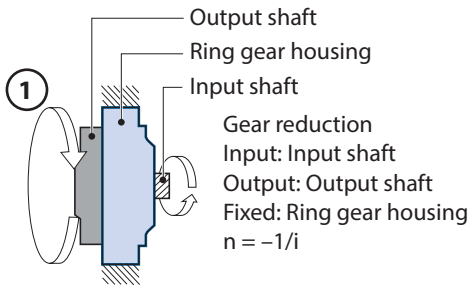

n = Speed ratio = (output speed/input speed)
("-" indicates the possible opposite direction)

i = reduction ratio

Output flange rotates

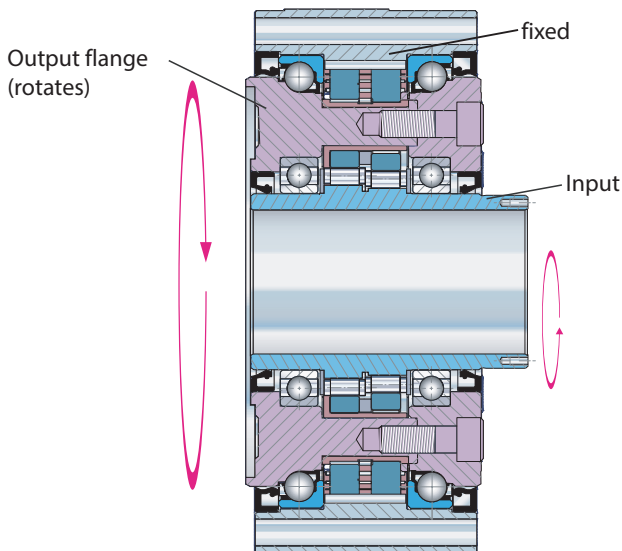

Catalogue reduction

Gearbox housing rotates

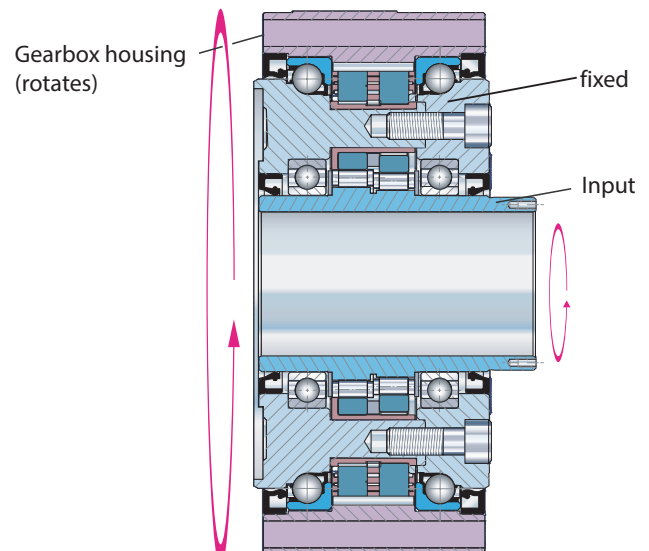

Catalogue gear reduction +1

1.5 Speed ratio and direction of rotation Series T and UA

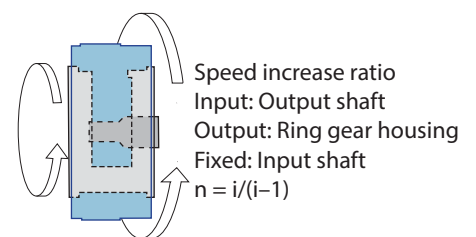
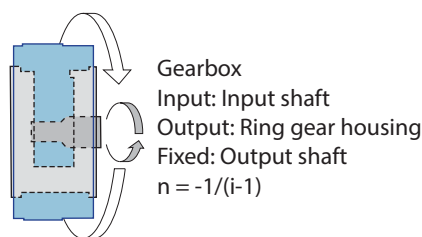
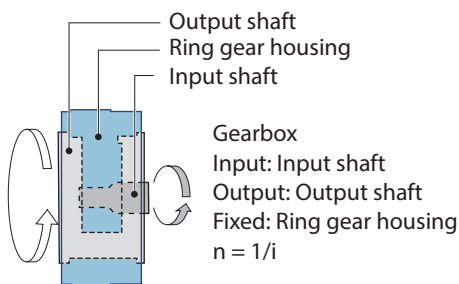

1.6 Speed ratio and rotation direction - Series ECY

The speed ratio and rotation direction depend on the positions of the input, output and stationary element, as shown in the illustrations below.

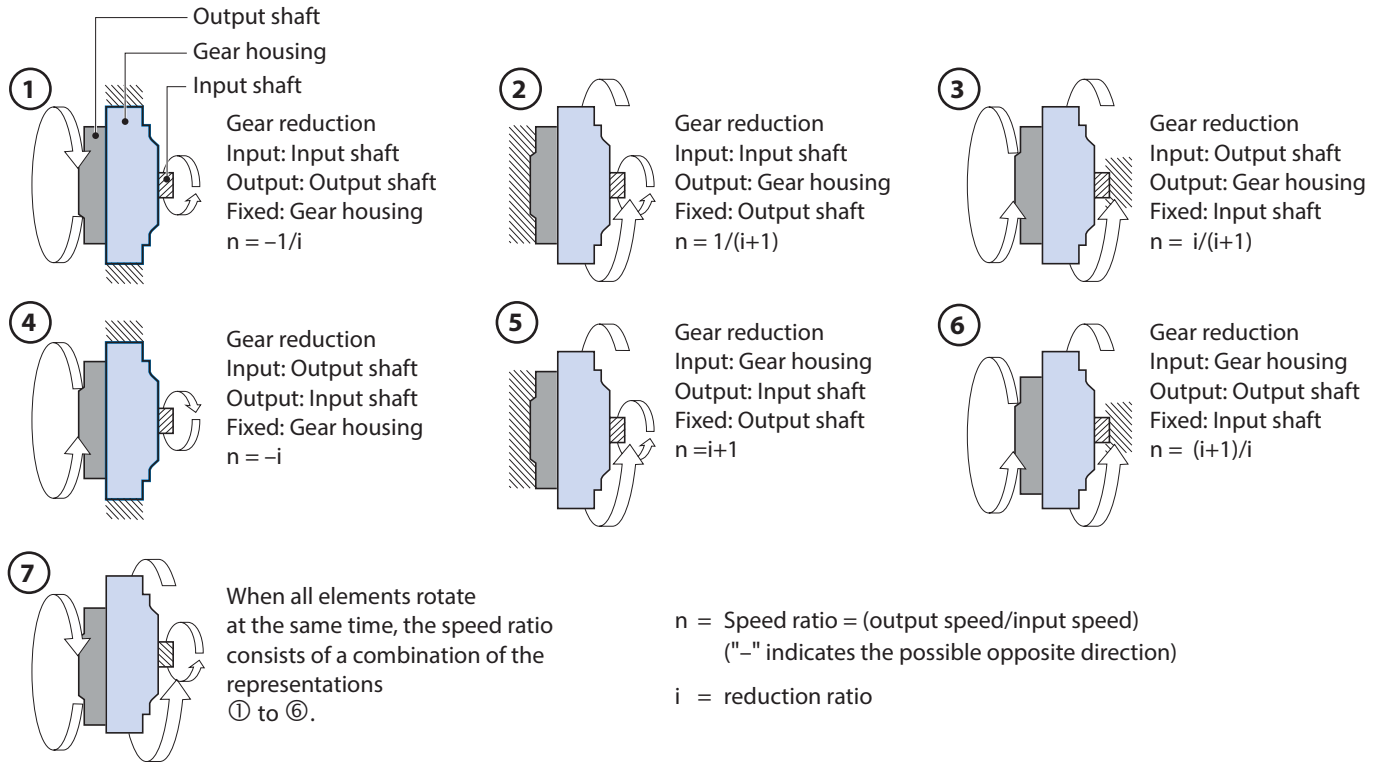

Output flange rotates

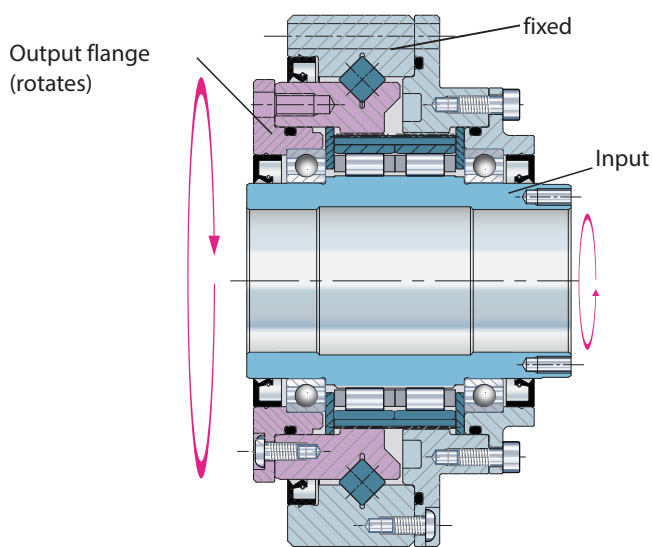

Catalogue reduction

Gearbox housing rotates

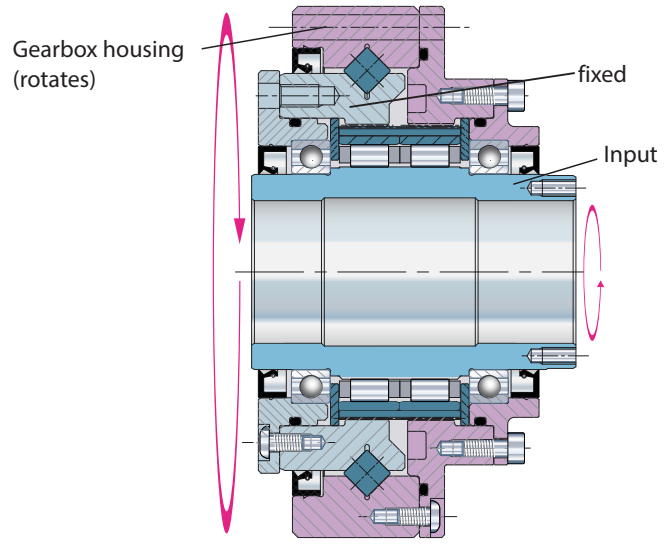

Catalogue gear reduction +1

1.7 Features and advantages

Compact design

The high reduction ratios, in one or a maximum of two stages, allow for extremely compact designs with a long lifetime. Moreover, due to the different versions available, these gearboxes can be optimally integrated into the machine environment.

Simple installation

The Series A, DA and C gearboxes are lubricated for life in the factory and completely sealed, as well as being maintenance-free. Convenient and simple motor mounting is also taken account of in all ranges.

Precise positioning

In more and more applications, high cycle speed and precise positioning are required in order to increase the efficiency of machines or to develop new applications. The special Cycloid systems of the Fine Cyclos offer high-precision positioning with maximum dynamics.

Precision gearbox with large hollow shaft bore and high capacity bearing

The C Series gearbox was specifically developed with an extra large hollow shaft bore through which supply lines, shafts, and other media can be passed. The integrated bearing can handle high loads on the output side that may arise when using machine tools, in positioning or during robotics applications.

The right size for every application

The wide range of gearbox series and the many size gradations within each series enable selection of the right gearbox for any precision application.

Gearboxes with external diameters ranging from 115 mm to 570 mm are available. With these, a range of acceleration torques from below 100 Nm up to 30,000 Nm can be covered.

In the event that the emergency stop function is activated, this precision gearbox can even be safely subjected to a load of 60,000 Nm.

High torsional stiffness and low mass moments of inertia

For these application areas, Sumitomo Drive Technologies has developed highly accurate series of backlash-free precision gearboxes. Compared with conventional gearboxes, the construction principle offers the highest torsional stiffness as well as low mass moments of inertia - ideal for highly dynamic tasks.

1.8 Application Examples



Axle drive for industrial robot

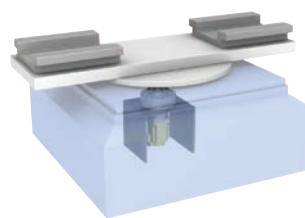

Pallet changer drive



Welding positioner

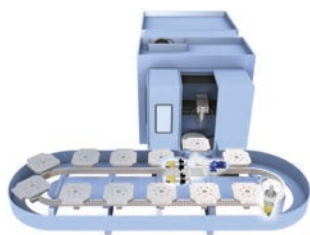

Machine tool
Automatic pallet pool input



Palletising robot



Liquid crystal transfer robot

2 Nomenclature

2.1 Fine Cyclo

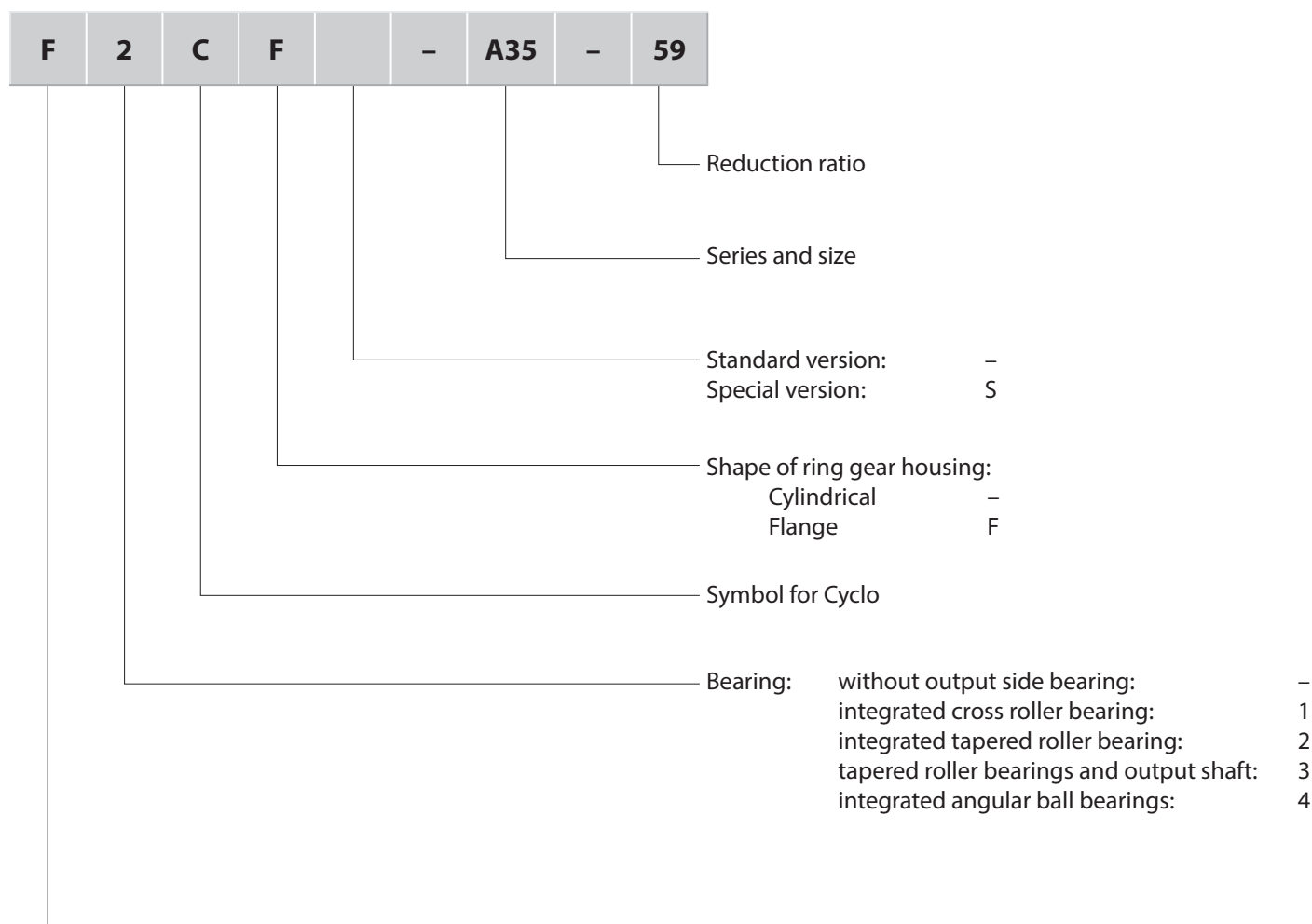

2.2 ECY series

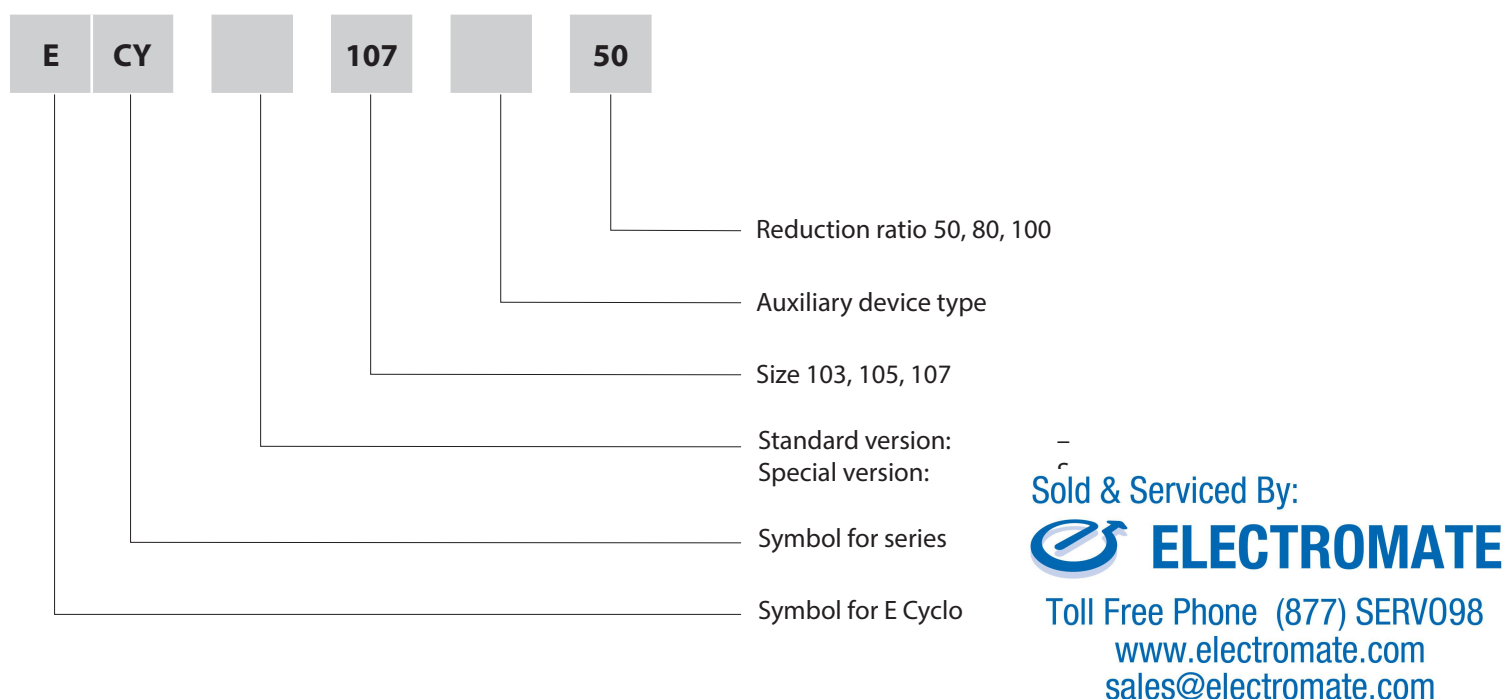

3 Gearbox selection

3.1 Reduction ratio and acceleration torque

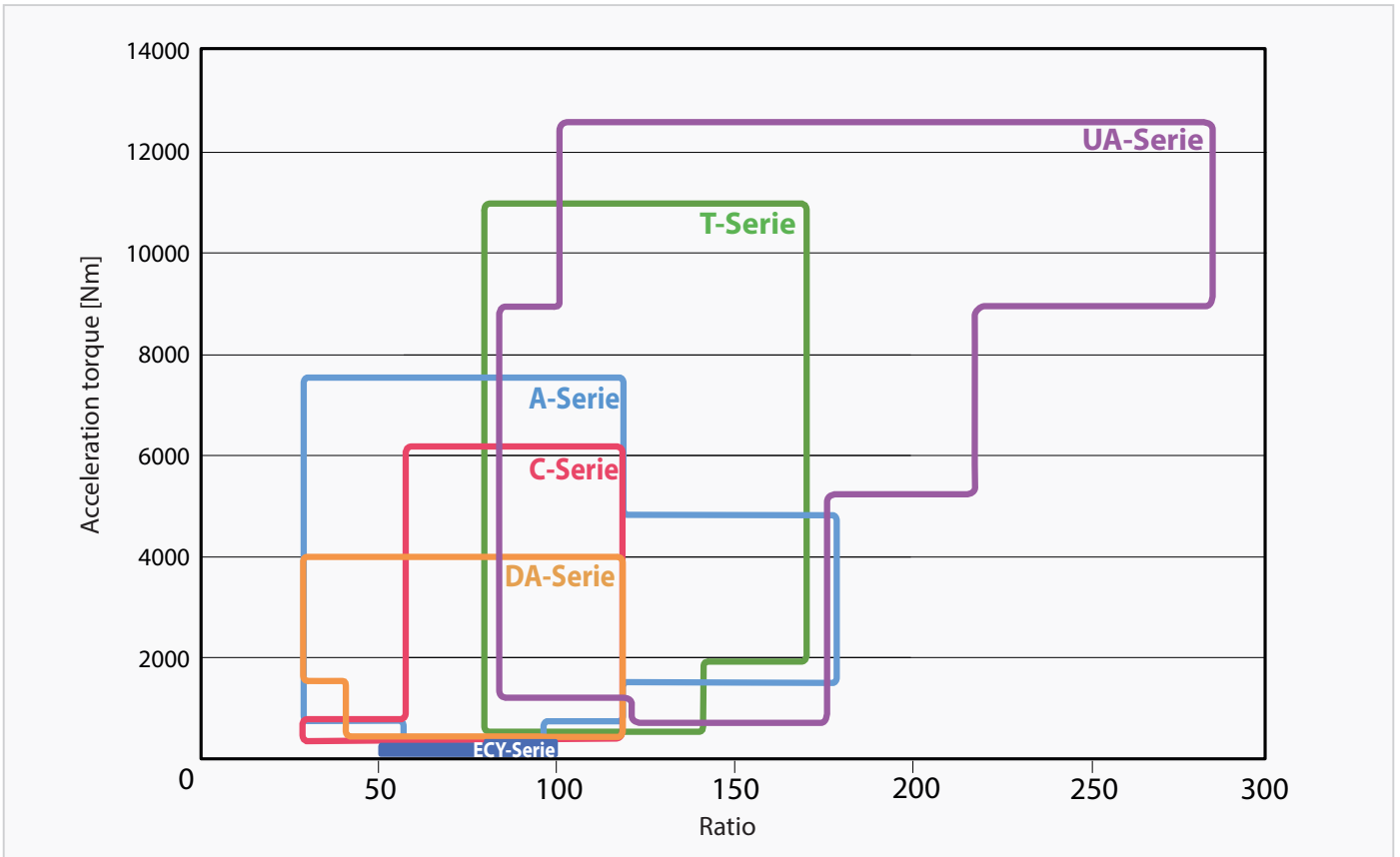

3.2 Max. bending moment on the output flange

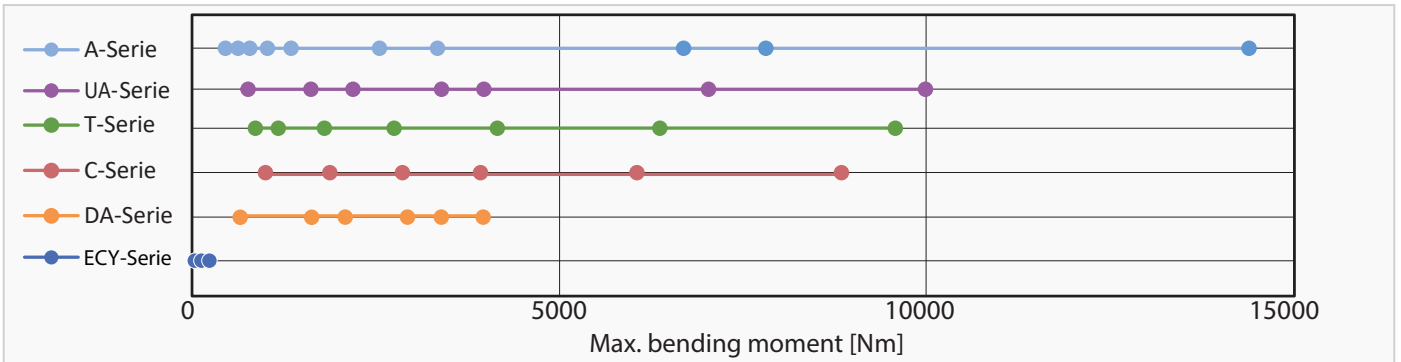

3.3 Max. hollow shaft diameter

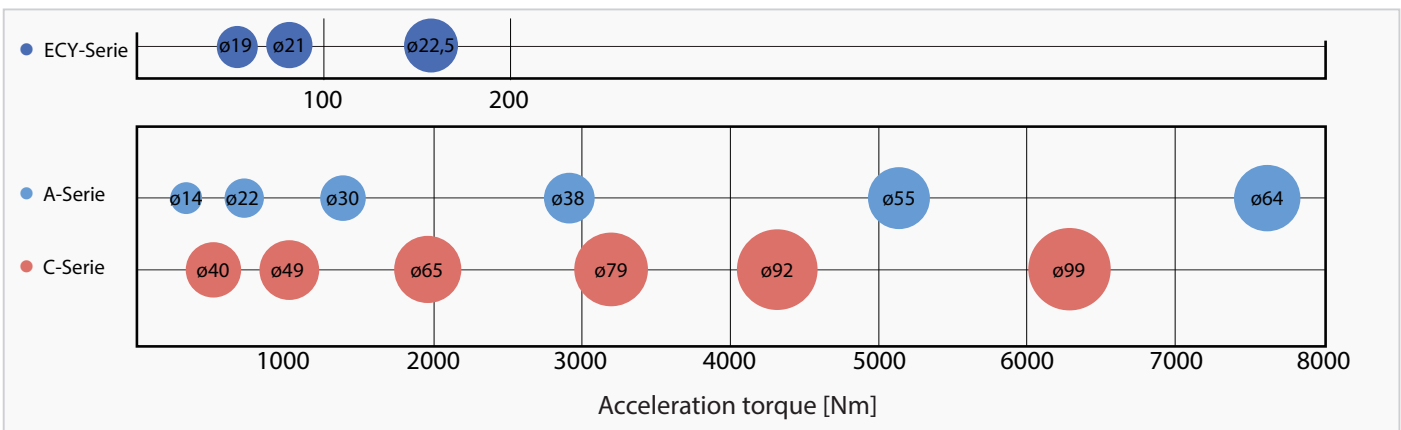

3.4 Reduction ratio and outer diameter

A Series

Special feature: The series offers a reduction kit with no bearing on the output side, as well as completely sealed variants and a gearbox with an output shaft instead of an output flange.

Optional: Available with motor adapter, customer-specific input shaft or output flange and other modifications.

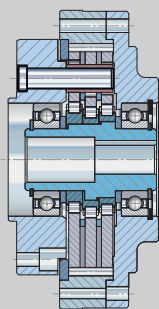
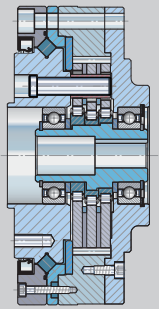
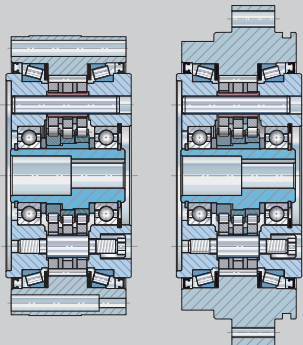
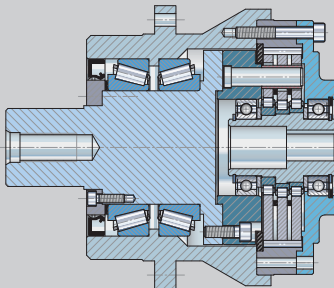
Model	Size	Available single-stage reduction ratios					Outer- ϕ flange	Outer- ϕ cylinder	Max. hollow shaft- ϕ
		29	59	89	119	179			
 FC-	A15G		•	•				115	14
	A25G	•	•	•	•			145	22
	A35G	•	•	•	•			180	30
	A45G	•	•	•	•	•		220	38
	A65G	•	•	•	•	•		270	55
	A75G	•	•	•	•			310	64
 F1C-	A15		•	•				140	14
	A25	•	•	•	•			170	22
	A35	•	•	•	•			205	30
	A45G	•	•	•	•	•		265	38
	A65G	•	•	•	•	•		350	55
	A75G	•	•	•	•			430	64
 F2C(F)-	A15		•	•			145	126	14
	A25	•	•	•	•		190	156	22
	A35	•	•	•	•		222	186	30
	A45	•	•	•	•	•	256	231	38
 F3C-	A15G		•	•				140	
	A25G	•	•	•	•			170	
	A35G	•	•	•	•			200	
	A45G	•	•	•	•	•		250	
	A65G	•	•	•	•	•		300	
	A75G	•	•	•	•			350	

•: available reduction ratio

DA Series

Special feature: The gearboxes are supplied with matching clamp ring adapter and motor flange.

Optional: The gearboxes are also available with other attachment variants or without a customer-specific flange.

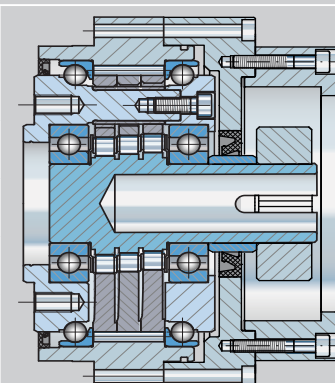
Model	Size	Available single-stage reduction ratios					Outer- ϕ flange	Outer- ϕ cylinder	Max. motor shaft- ϕ with clamp ring design
		29	41	59	89	119			
 F4CF-	DA15		•	•	•	•	136	CF	19
	DA25	•	•	•	•	•	159	CF	24
	DA35	•	•	•	•	•	189	CF	32
	DA40		•	•	•	•	198	CF	32
	DA45	•	•	•	•	•	221	CF	38
	DA50		•	•	•	•	238	CF	38

•: available reduction ratio

C Series

Special feature: The large diameter of the hollow shaft allows for effective use of space for feeding through cables or other media.

Optional: Customer-specific customisation of input shaft, output flange, and housing possible.

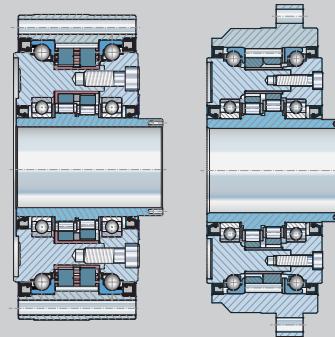
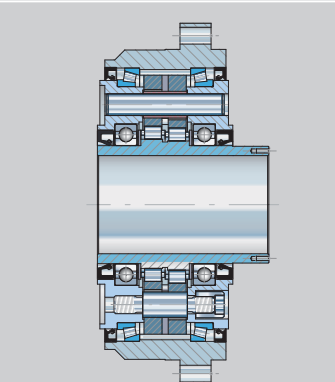
Model	Size	Available single-stage reduction ratios				Outer- ϕ flange	Outer- ϕ cylinder	Standard hollow shaft- ϕ
		29	59	89	119			
 F4C(F)-	C15	•	•	•	•	CF	160	40
	C25		•	•	•	CF	185	49
	C35		•	•	•	256	CF	65
 F2CF-	C45		•	•	•	292	CF	79
	C55		•	•	•	325	CF	92
	C65		•	•	•	362	CF	99

•: available reduction ratio

UA Series

Recommended for: Pallet changers, bending heads, tool changers, disc magazines, chain magazines, tilting tables.

Special feature: Spur gear prestage, gearbox with high positioning and path accuracy, even under frequently changing dynamic conditions.

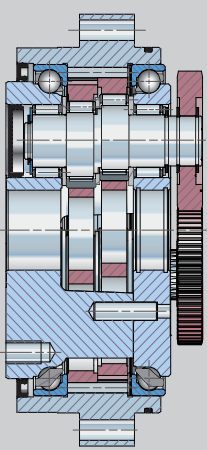
Model	Size	Available double stage reduction ratios				Outer-Ø flange	Outer-Ø cylinder	Max. motor shaft-Ø (larger diameters available on request)	
		50 - 99	100 -149	150 -199	200 -300				
F4CF-		UA15	60 84	91 127	139 171		133	90	24
		UA25	78 88	115 124 145	173		165	110	24
		UA35	82 87	121	152 166		189	130	38
		UA45	82 99	121 130	152 166		224	155	38
		UA55	81 97	126 145	169	241	244	174	38
F2CF-		UA65	89	121 136	155 166 190	239 283	295	210	38
		UA80	93	103 122	155 166 190	239 283	325	238	48

T Series

Special feature: Gearboxes with high positioning and path accuracy, even under highly fluctuating dynamic conditions

Optional: Fitting of motors without key with clamp ring design possible

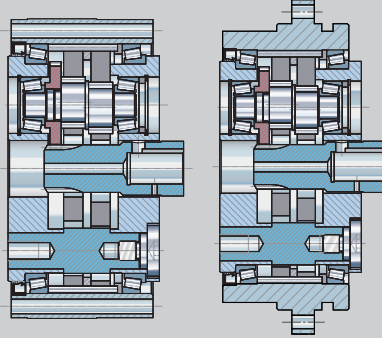
Model	Size	Available double stage reduction ratios				Outer-Ø flange	Outer-Ø cylinder	Max. motor shaft-Ø with keyway (clamp ring design on request)	
		81	118.5	141	171				
F2C(F)-		T155	•	•	•		145	126	14
		T255	•	•	•		190	156	17
		T355	•	•	•		222	186	22
		T455	•	•	•	•	256	231	28
		T555	•	•	•	•	292	261	28
		T655	•	•	•	•	325	296	35
		T755	•	•	•	•	370	331	35

•: available reduction ratio

Sold & Serviced By:



Toll Free Phone (877) SERV098

www.electromate.com

sales@electromate.com

ECY Series

Special feature: The series offers a reduction kit with no bearing on the output side, as well as completely sealed variants and a gearbox with an output shaft instead of an output flange.

Optional: Available with motor adapter, customer-specific input shaft or output flange and other modifications.

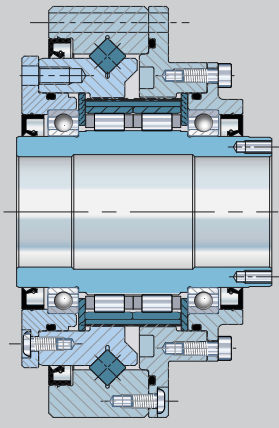
Model	Size	Available double stage reduction ratios			Outer-Ø flange	Outer-Ø cylinder	Max. hollow shaft-Ø
		50	80	100			
 <p>EYC</p>	103	•	•	•	74	-	19
	105	•	•	•	84	-	21
	107	•	•	•	95	-	25.5

•: available reduction ratio

Sold & Serviced By:



Toll Free Phone (877) SERV098
www.electromate.com
sales@electromate.com

3.5 Torques and speeds

Maximum permissible input speed n_{1ED}

The gearbox can be used within the maximum input speed range indicated in the table, however, the max. permissible mean input speed is limited by the duty cycle (%ED).

Model	Size	Reduction ratio i	Max. permissible input speed n_{1ED} [min ⁻¹]		Max. acceleration torque [Nm]	Max. torque for Emergency Stop [Nm]
			50% ED	100% ED		
A Series						
FC- F1C- F2C- F3C-	A15(G)	59 / 89	5600	2800	335	785
	A25(G)	29	3100	1550	721	1930
		59 / 89 / 119	4200	2100	721	1930
	A35(G)	29	2500	1250	1390	3580
		59 / 89 / 119	3300	1650	1390	3580
	A45(G)	29	1900	950	2910	7210
		59 / 89 / 119 / 179	2600	1300	2910	7210
A65(G)	29	1500	750	5130	13800	
	59 / 89 / 119 / 179	2000	1000	5130	13800	
A75(G)	29	1200	600	7610	24000	
	59 / 89 / 119	1750	850	7610	24000	
DA Series						
F4CF-	DA15	41 / 59 / 89	5600	2800	613	1225
	DA25	29 / 41 / 59 / 89 / 119	4200	2100	1029	2058
	DA35	29 / 41 / 59 / 89 / 119	3300	1650	1960*	3920
	DA40	41 / 59 / 89 / 119	2900	1450	2500	5000
	DA45	29 / 41 / 59 / 89 / 119	2600	1300	3062*	6125
	DA50	41 / 59 / 89 / 119	2400	1200	4000	8000
C Series						
F4C(F)-	C15	29	2400	1200	540	1080
		59 / 89 / 119	3200	1600	540	1080
	C25	59 / 89 / 119	2900	1450	1030	2060
F2CF-	C35	59 / 89 / 119	2100	1050	1962	3924
	C45	59 / 89 / 119	1800	900	3188	6377
	C55	59 / 89 / 119	1500	750	4316	8633
	C65	59 / 89 / 119	1400	700	6278	12577
ECY Series						
	103	50 / 80 / 100	8500	2500	54*	110
	105	50 / 80 / 100	7300	2500	82*	147
	107	50 / 80 / 100	6500	2000	157*	284

* varies according to ratio

Sold & Serviced By:
 **ELECTROMATE**
 Toll Free Phone (877) SERV098
www.electromate.com
sales@electromate.com

Model	Size	Reduction ratio i	Max. permissible output speed $n_{2\max}$ [rpm]	Max. acceleration torque [Nm]	Max. torque for Emergency Stop [Nm]
UA Series					
F4CF-	UA15	60 / 84 / 91 / 127 / 139 / 171	60	625	1250
	UA25	78 / 88 / 115 / 124 / 145 / 173	50	1250	2500
	UA35	82 / 87 / 121 / 152 / 166	40	2250	4500
	UA45	82 / 99 / 121 / 130 / 152 / 166	30	3300	6600
	UA55	81 / 97 / 126 / 145 / 169 / 241	30	5000	10000
F2CF-	UA65	89 / 121 / 136 / 144 / 163 / 171 / 199 / 249	30	8575	17150
	UA80	93 / 103 / 122 / 155 / 166 / 190 / 239 / 283	25	12500	25000
T Series					
F2C(F)-	T155	81 / 118.5 / 141	60	417	834
	T255	81 / 118.5 / 141	50	1030	2060
	T355	81 / 118.5 / 141	40	1960	3920
	T455	81 / 118.5 / 141 / 171	30	3190	6380
	T555	81 / 118.5 / 141 / 171	30	4910	9820
	T655	81 / 118.5 / 141 / 171	25	7850	15700
	T755	81 / 118.5 / 141 / 171	25	11000	22000

Sold & Serviced By:



Toll Free Phone (877) SERV098
www.electromate.com
sales@electromate.com

3.6 Flow chart and equation of selection

See chapter "Flussdiagramm und Auswahlformel" on page 150 for information on the ECY series.

Sumitomo Drive Technologies would be happy to take over the selection and calculation process for you. Please refer to the application data sheet in the appendix.

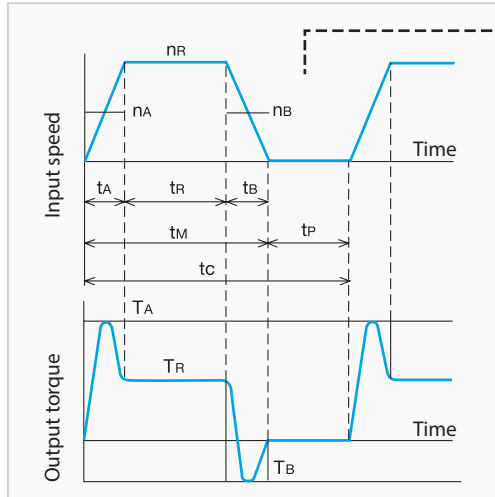
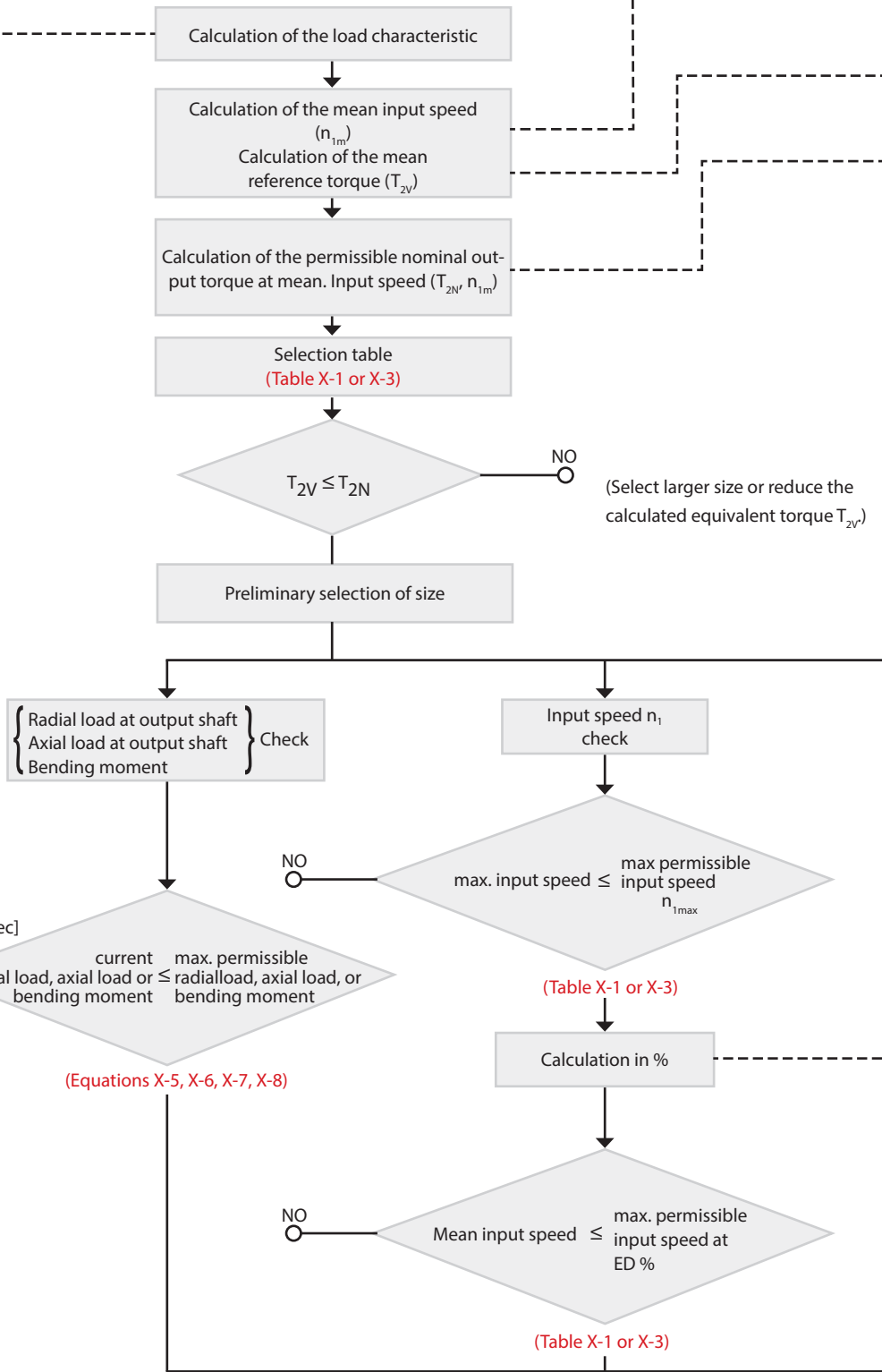

Fig. 6 Load cycle

- n_{1A} : Mean input speed during start-up [min^{-1}]
as per Fig. 6 $n_{1A} = \frac{n_{1R}}{2}$
- n_{1R} : Input speed during uniform movement [min^{-1}]
- n_{1B} : Mean Input speed during braking [min^{-1}]
as per Fig. 6 $n_{1B} = \frac{n_{1R}}{2}$
- n_{1m} : Mean input speed [min^{-1}]
- t : Time [sec.]
- t_A : Run-up time [sec.]
- t_R : Duration of uniform movement [sec.]
- t_B : Braking time [sec.]
- t_M : Duration of the movement phase of a working cycle [sec.]
- t_P : Duration of pauses [sec.]
- t_C : Duration of a working cycle [sec.]
- T_{2A} : Output side acceleration torque [Nm]
- T_{2R} : Output torque at constant speed [Nm]
- T_{2B} : Output side braking torque [Nm]
- T_{2V} : Reference torque [Nm]
- T_{2N} : Nominal output torque [Nm]
- $T_{2N \max}$: Maximum permissible nominal output torque [Nm]
- $T_{2N 600}$: Nominal output torque at $n_1 = 600 \text{ min}^{-1}$ [Nm]
- B_{f2} : Service factor output
- ED: Duty cycle %



The tables and equations relating to the references marked red are located in the respective sections covering the series (A, DA, C, UA, and T):

	Page number				
	A	DA	C	UA	T
Table X-1	S. 28	S. 64	S. 86	S. 104	S. 128
Table X-2	S. 28	S. 64	S. 86	S. 106	S. 128
Table X-3	S. 30	S. 66	S. 88	S. 108	S. 130

	Page number				
	A	DA	C	UA	T
Equation X-1	S. 35	S. 71	S. 93	-	-
Equation X-5	from S. 37	S. 73	S. 95	S. 115	S. 135
Equation X-6,7	from S. 37	S. 73	S. 95	S. 115	S. 135
Equation X-8	from S. 37	S. 73	S. 95	S. 115	S. 135

Calculation in load condition as per Fig. 6

○ Mean input speed $n_{1m} = \left(\frac{t_A \cdot n_{1A} + t_R \cdot n_{1R} + t_B \cdot n_{1B}}{t_M} \right)$ (Equation - 8)

○ Mean reference torque $T_{2V} = \left(\frac{t_A \cdot n_{1A} \cdot T_{2A}^3 + t_R \cdot n_{1R} \cdot T_{2R}^3 + t_B \cdot n_{1B} \cdot T_{2B}^3}{t_M \cdot n_{1m}} \right)^{1/3} \cdot B_{f2}$ (Equation - 9)

○ Max. permissible nominal output torque at mean input speed

$T_{2Nmax} = T_{2N,600} \cdot \left(\frac{600}{n_{1m}} \right)^{0.3}$ For single-stage gearboxes	$T_{2N} = T_{2N,15} \cdot \left(\frac{15}{n_{2m}} \right)^{0.3}$ For double-stage gearboxes
------------------------------------------------------------------------------------------------------	-------------------------------------------------------------------------------------------------

(Equation -10)

○ ED % $ED \% = \left(\frac{t_m}{t_c} \right) \cdot 100 [\%] = \left(\frac{t_c - t_p}{t_c} \right) \cdot 100 [\%]$ (Equation -11)

$T_{2N,600}$: Nominal output torque at an input speed of 600 min⁻¹ (Table X-3)

Please note the instructions on duty cycle in chapter 4.

If $n_{1m} < 600 \text{ min}^{-1}$, the value in the table at input speed of 600 min⁻¹ applies for T_{2N} .

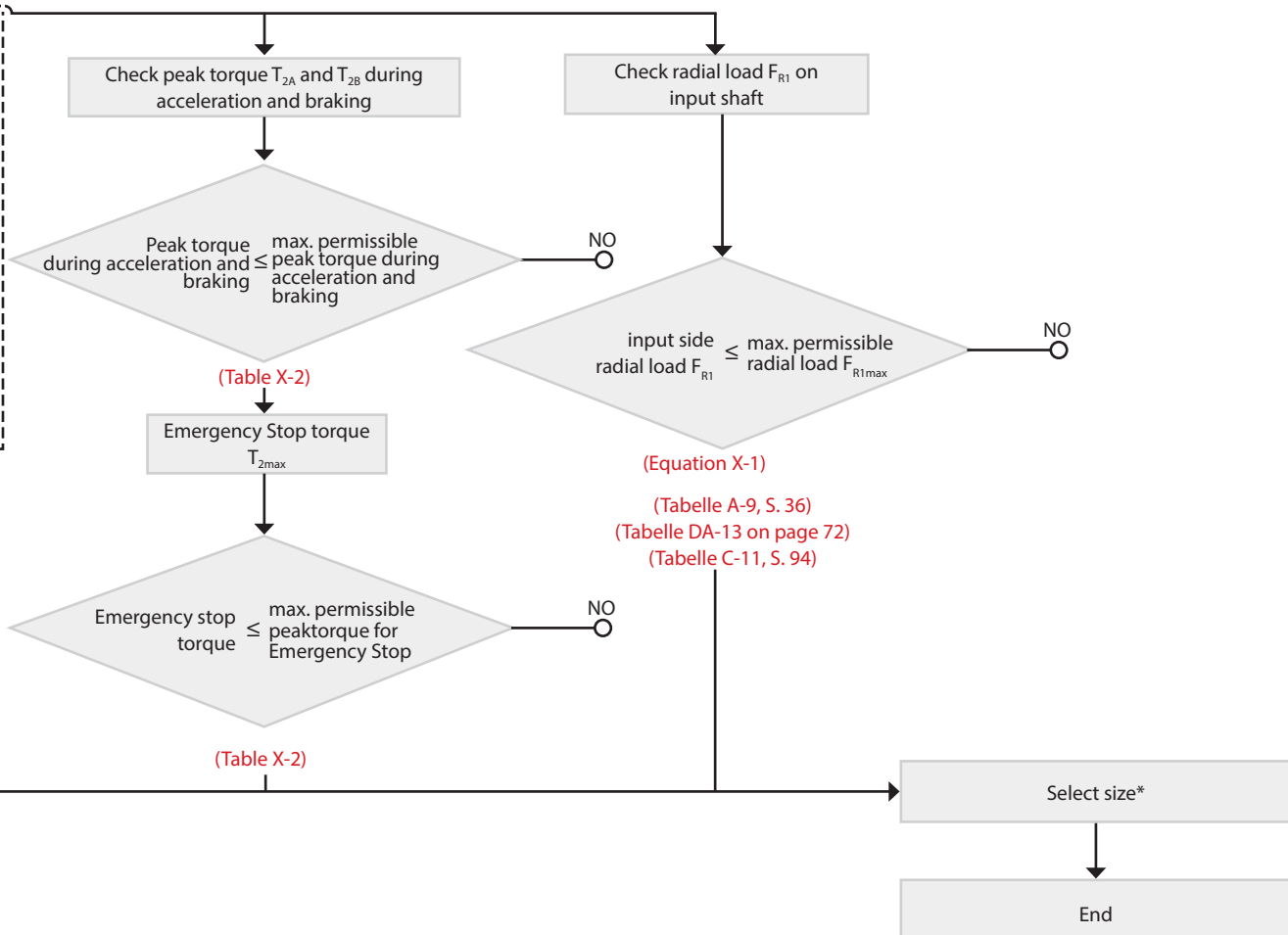

* When selecting the motor, the input side breakaway torque (BTI) or no-load running torque (NLRT) must be taken into account.

3.6.1 Selection example

Calculation example for Type F4C-C25-119 for the following specification:

T_{2A}	= output side acceleration torque	600 Nm
T_{2R}	= output torque at constant speed	250 Nm
T_{2B}	= output side braking torque	400 Nm
T_{2max}	= emergency stop torque	1700 Nm (1000 x over the entire lifetime)
n_{1A}	= mean input speed during start-up	1250 min ⁻¹
n_{1R}	= input speed during same-shape movement	2500 min ⁻¹
n_{1B}	= mean input speed during braking	1250 min ⁻¹
t_A	= start-up time	0.3 sec
t_R	= duration of the same-shape movement	3.0 sec
t_B	= time for braking	0.3 sec
t_m	= duration of the movement phase of a working cycle	3.6 sec
t_p	= duration of pause time	3.6 sec
t_c	= duration of a working cycle	7.2 sec
F_{R1}	= radial load on input shaft	driven by timing belt , minor shocks, $F_{R1} = 196$ N, with force application point 25 mm
F_{R2}	= radial load on the output shaft	Connection with gear, minor shocks, $F_{R2} = 4116$ N, 55 mm from the side of the flange

It was taken into account that this gearbox is used to operate a robot linkage at uniform load (see Tabelle C-14 service factor (B_p), S. 94.

Mean input speed $n_{1m} = \left(\frac{0.3 \cdot 1250 + 3.0 \cdot 2500 + 0.3 \cdot 1250}{3.6} \right) = 2292$ rpm

Mean reference torque $T_{2V} = \left(\frac{0.3 \cdot 1250 \cdot 600^3 + 3.0 \cdot 2500 \cdot 250^3 + 0.3 \cdot 1250 \cdot 400^3}{3.6 \cdot 2292} \right)^{1/3} \cdot 1 = 300$ Nm

Max. permissible output torque at mean input speed $T_{2Nmax} = 568 \cdot \left(\frac{600}{2292} \right)^{0.3} = 380$ Nm ≥ 300 Nm \Rightarrow Type **F4C-C25-119**

Calculation of ED % $ED \% = \left(\frac{3.6}{7.2} \right) \cdot 100 = 50\%$

Sold & Serviced By:



Toll Free Phone (877) SERV098
www.electromate.com
sales@electromate.com

○ Checking the maximum input speed $n_1 = 2500 \text{ min}^{-1} < n_{1 \text{ max}} = 3500 \text{ min}^{-1}$ (Table C-1)

○ Checking the mean input speed $n_{1 \text{ m}} = 2292 \text{ min}^{-1}$ at 50% ED $< n_{1 \text{ m max}} = 2900 \text{ min}^{-1}$ at 50% ED (Table C-1)

○ Checking the peak torque during acceleration and braking $T_{2 \text{ A}} = 600 \text{ Nm} < 1030 \text{ Nm}$ (Table C-2)

○ Checking the Emergency Stop torque $T_{2 \text{ max}} = 1700 \text{ Nm} < 2060 \text{ Nm}$ (Table C-2)

○ Max. permissible radial load on input shaft under consideration of correction factors $F_{R1 \text{ max}} = F_{R1, 600} \times \left(\frac{600}{n_{1 \text{ m}}}\right)^{1/3} = 841 \cdot \left(\frac{600}{2292}\right)^{1/3} = 538 \text{ N}$

$$F_{R1} = \frac{F_{R1 \text{ max}}}{L_{f1} \cdot C_{f1} \cdot B_{f1}} = \frac{538}{1.14 \cdot 1.25 \cdot 1.2} = 315 \text{ N} > 196 \text{ N}$$

(Tabelle C-11, Equation C-1, see S. 93 ff.)

○ Checking the max. permissible bending moment T_k $l_r = x - a + l_1 = 55 - 43,2 + 162 = 173,8 \text{ mm}$
Calculated dimension for bending moment l_r

○ Correction factors are used to calculate the external bending moment

$$C_{f2} = 1.25 ; B_{f2} = 1.0$$

$$T_k = C_{f2} \cdot B_{f2} \cdot F_{R2} \cdot l_r < T_{k \text{ max}}$$

$$T_{ke} = 1.25 \cdot 1.0 \cdot 4116 \cdot 173.8 \cdot 10^{-3}$$

$$T_{ke} = 891 \text{ Nm} < 1850 \text{ Nm}$$

Selection / result

⇒ Type **F4C-C25-119** was selected as a result of the above evaluation.

Sold & Serviced By:



Toll Free Phone (877) SERV098
www.electromate.com
sales@electromate.com

4 Description of technical specifications for cycloidal gearboxes

Stiffness and Lost Motion

If a torque is introduced in the output shaft when the input shaft is stationary, the relation between the distortion angle and the torque can be read off on the following hysteresis curve (Fig. 7).

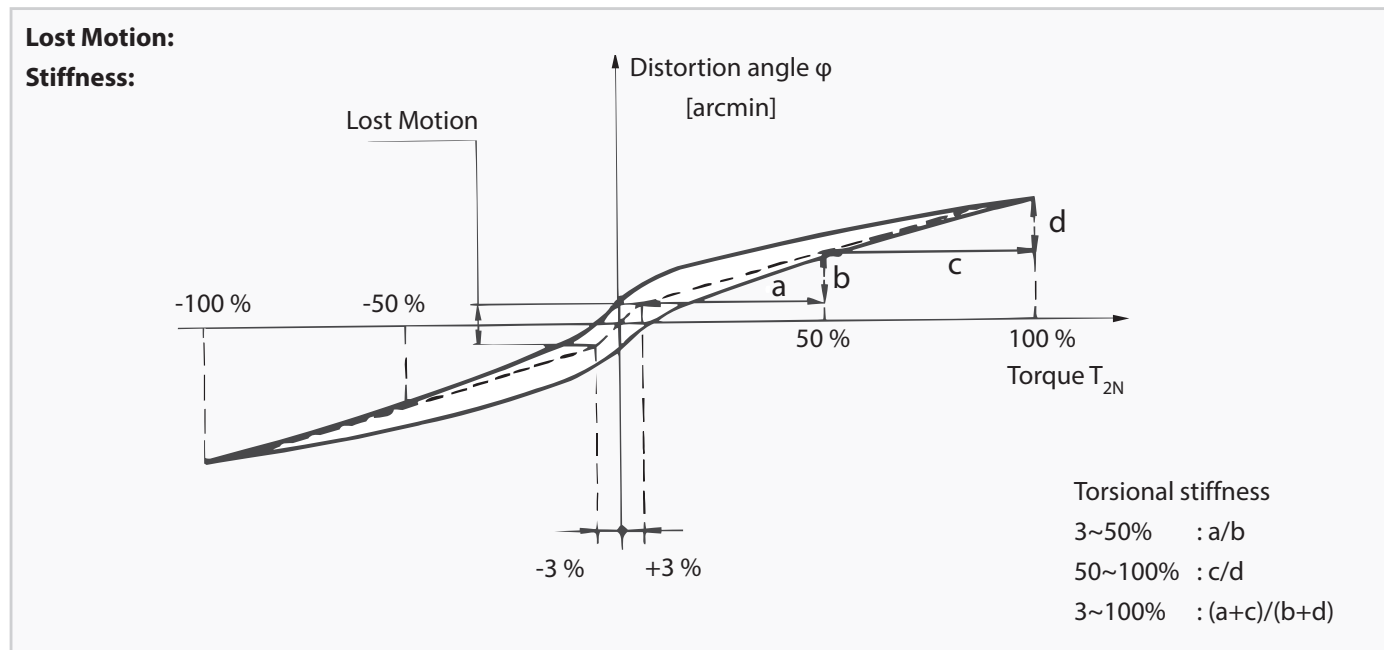

Fig. 7 Hysteresis curve

Lost Motion: Distortion angle at 3% of nominal torque.

Stiffness: Inclination of a straight line connecting two points on the hysteresis curve.
 The table value indicates the average torsional stiffness as a function of the nominal output torque.

Note arcmin means "angular minute"
 $1 \text{ arcmin} = \frac{1^\circ}{60}$

No-load running torque

No-load running torque must be applied to keep the gearbox in motion without load at the output. The information in the catalogue refers to average values which occur after the gearbox has been run in.

Breakaway torque

Specifies the torque which is necessary to "break loose" the load-free gearbox from standstill, i.e. to start a rotational movement. This can take place on both the input (BTI) and the output side (BTO).

Efficiency

Efficiency varies according to speed, load torque, grease temperature, reduction ratio, gearbox size, etc. The dependency between efficiency and input speed is shown in the figures relevant to the respective series, under measurement conditions with permissible output torque and stable grease temperature. Variations in models and different reduction ratios are taken into account in the efficiency curve.

Transmission error

The transmission error indicates the deviation of the actual rotation angle of the gearbox from the theoretical value. A defined input-side rotation of the gearbox divided by the reduction ratio gives the theoretical position of the output. The actual angle of rotation varies with a deviation of some angular seconds around this value.

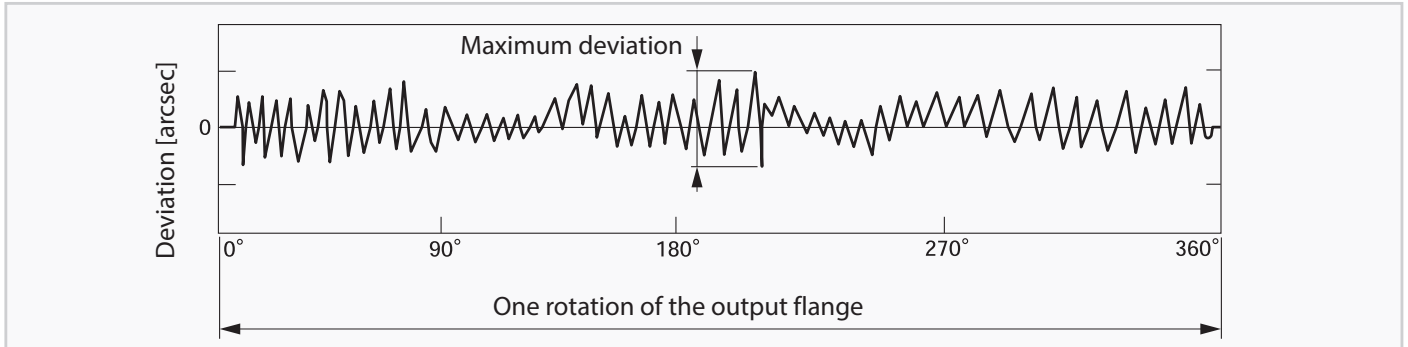

Fig. 8 Typical transmission error

Note arcsec means "angular second"
 $1 \text{ arcsec} = \frac{1^\circ}{3600}$

Applications for precision gearboxes generally differentiate between positioning and smooth traverse applications.

For positioning applications only the standstill positions of the gearbox play a role (e.g., tool magazine). Here, the transmission error is usually not important.

For smooth traverse applications, precision is important at every moment of movement (e.g. continuously welding robots). Here, a major transmission error can lead to unsatisfactory results.

Fine Cyclo reducers are ideally suited for both applications. Both single-stage and double-stage gearboxes show only minimal transmission errors. If maximum path accuracy is required, Fine Cyclo double-stage gearboxes provide additional advantages. Please contact Sumitomo Drive Technologies for assistance in choosing the correct gearbox.

Load cycle

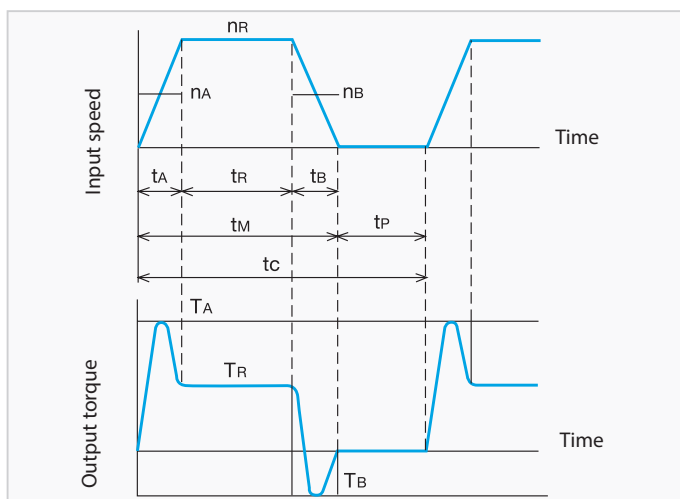

The load cycle (t_c) reflects the sequence of movements in the application used. This typically consists of at least one acceleration phase (t_A), one constant speed phase (t_R), one deceleration (t_B), and one pause of movement (t_P).

Sold & Serviced By:



Toll Free Phone (877) SERV098
www.electromate.com
sales@electromate.com

Duty cycle

The duty cycle is the percentage duration of the movement phase in proportion to the duration of the working cycle within a periodically repeating load cycle. In particular, the speed and duty cycle, as well as the torque and the installation situation (e.g. convection or external heat influence) determine the temperature development in the gearbox. Continuous operation of the gearbox at high speeds or duty cycles lead to overheating and destruction of the gearbox. To avoid this, the temperature of the gearbox housing during operation should not exceed 70 °C.

Therefore, a few basic principles must be taken into account.

For F_C-A; DA; C and UA:

The measuring basis is intermittent duty (S5 operation) on the basis of maximum 10 min running time (t_c), which includes an pause time. This means that it is necessary to check the allowed mean input speed n_{1m} according to the permitted nominal speed for %ED ($n_{1m} < n_{1ED}$). For duty cycles of less than 50%, we recommend using 50%ED nominal speeds, and for those greater than 50%, 100%ED nominal speeds, for checking n_{1m} .

For F2C-T:

The measuring basis for F2C-T is the maximum output speed (n_{2max}), which corresponds simultaneously to the limit speed allowed in continuous operation (100 %ED). It is therefore necessary to check the maximum occurring speed n_{2max} in the movement cycle against the limiting speed n_{2max} . Checking against a permissible nominal speed according to %ED can be omitted here.

Further:

If the duration of the movement phase of a working cycle t_M is greater than 10 minutes, in the case of continuous duty (S1) or if complex load cycles are performed, please consult Sumitomo Drive Technologies.

Sold & Serviced By:



Toll Free Phone (877) SERV098
www.electromate.com
sales@electromate.com

Sold & Serviced By:



Toll Free Phone (877) SERV098
www.electromate.com
sales@electromate.com

5 A-Series

FC-A

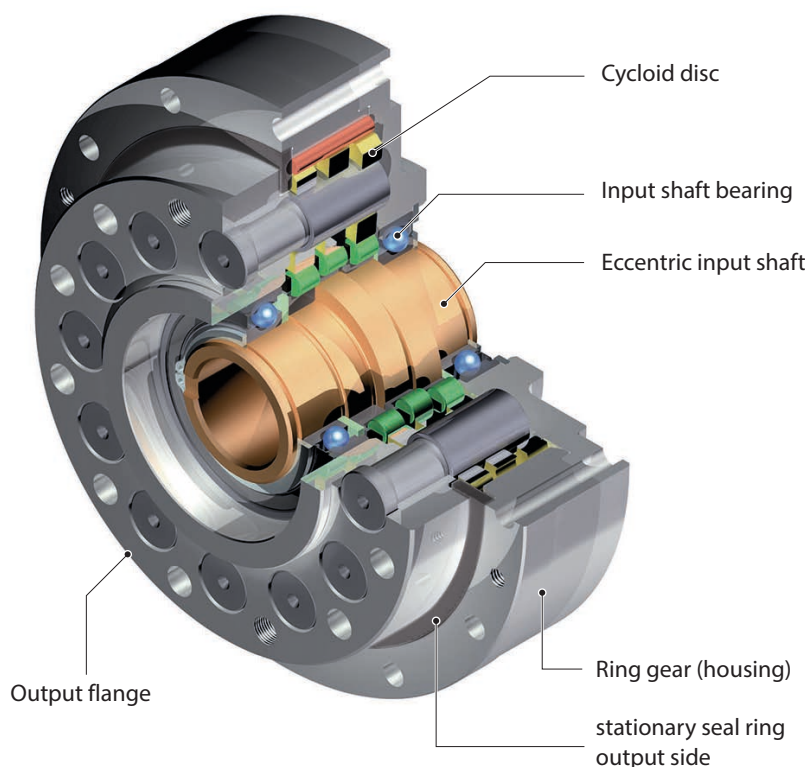

Special feature:

User can use their own bearings, hollow shaft possible, compact reduction kit

- 6 sizes
- Ratios (single-stage)
29/59/89/119/179
- Can be customised to fit individual designs
- Smaller occupied space
- Nominal output torques up to 5140 Nm
- Acceleration torques up to 7610 Nm
- Input speeds up to 6150 min⁻¹
- Lost Motion < 2 arcmin (optional Lost Motion < 1 arcmin)

F1C-A

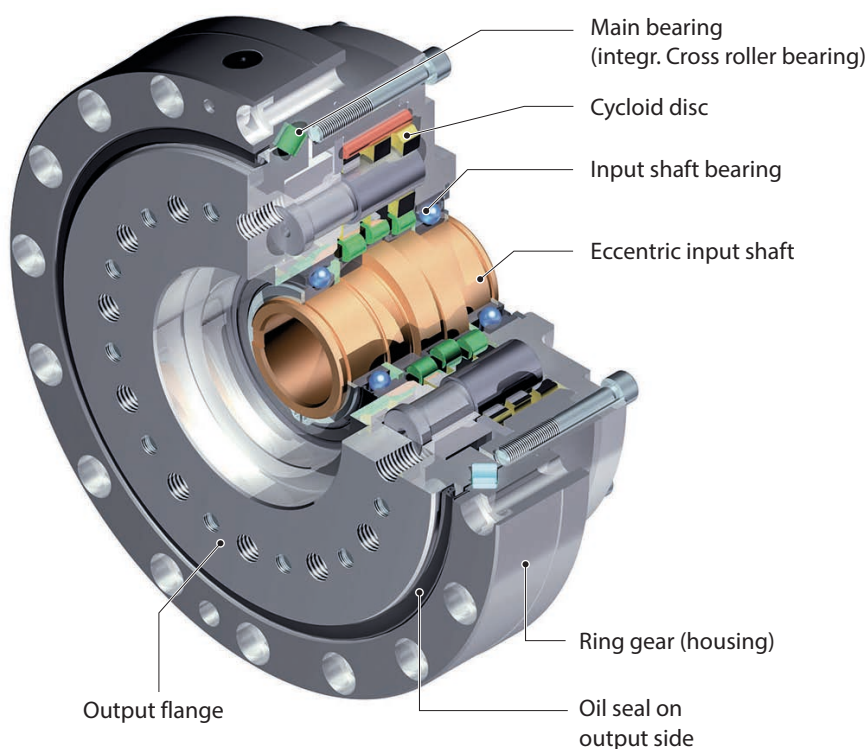

Special feature:

High stiffness, compact design

- 6 sizes
- Reduction ratios (single-stage)
29/59/89/119/179
- Nominal output torques up to 5140 Nm
- Acceleration torques up to 7610 Nm
- Input speeds up to 6150 min⁻¹
- Lost Motion < 2 arcmin (optional Lost Motion < 1 arcmin)

Sold & Serviced By:



Toll Free Phone (877) SERV098

www.electromate.com

sales@electromate.com

F2C-A

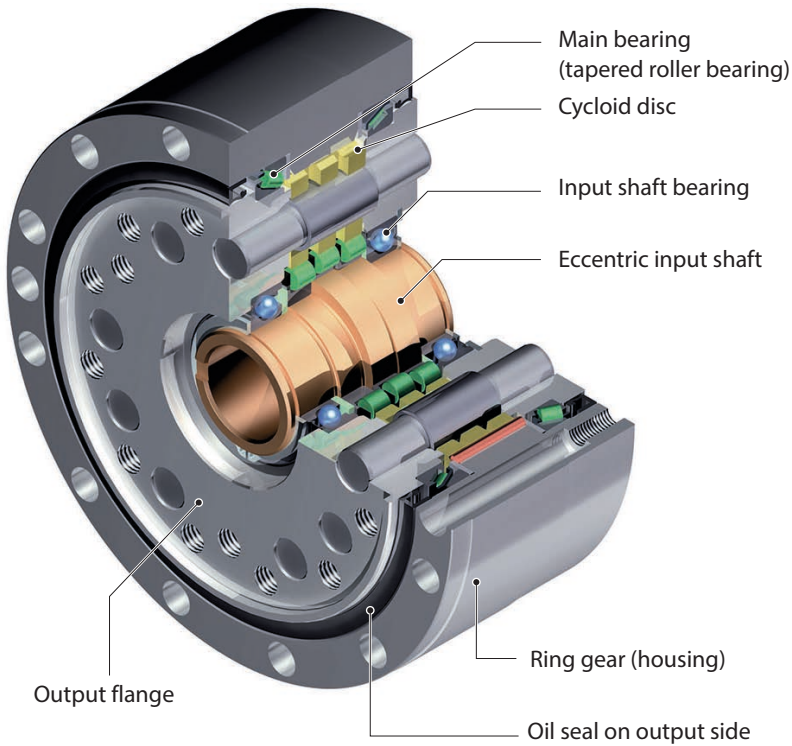

Special feature:

Low noise, high stiffness, compact design

- 4 sizes
- Ratios (single-stage) 29/59/89/119/179
- Tapered roller bearings with high permissible tilting moments
- Nominal output torques up to 1830 Nm
- Acceleration torques up to 2910 Nm
- Input speeds up to 6150 min⁻¹
- Lost Motion < 2 arcmin (optional Lost Motion < 1 arcmin)

F3C-A

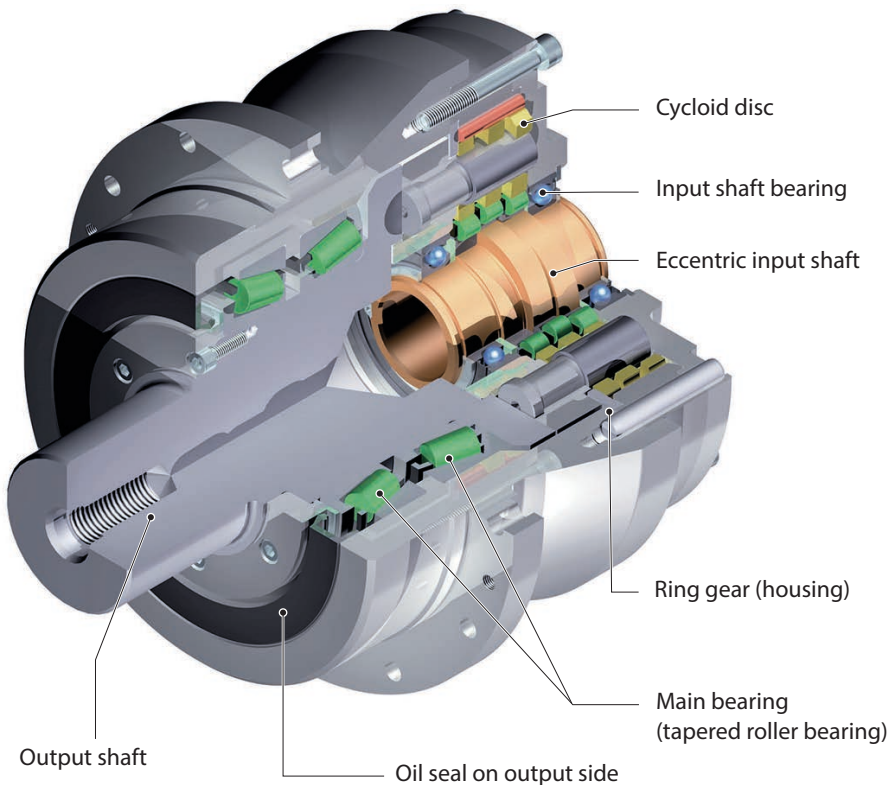

Special feature:

Allows high radial forces

- 6 sizes
- Ratios (single-stage) 29/59/89/119/179
- Nominal output torques up to 5140 Nm
- Acceleration torques up to 7610 Nm
- Input speeds up to 6150 min⁻¹
- Lost Motion < 2 arcmin (optional Lost Motion < 1 arcmin)

Sold & Serviced By:



Toll Free Phone (877) SERV098

www.electromate.com

sales@electromate.com

5.1 Torques according to output speeds

Output speed n_{2m} [min ⁻¹]		5			10			15			20			25			
Model	Size	Reduction ratio i	Nominal output torque	Input speed	Max. permissible input power	Nominal output torque	Input speed	Max. permissible input power	Nominal output torque	Input speed	Max. permissible input power	Nominal output torque	Input speed	Max. permissible input power	Nominal output torque	Input speed	Max. permissible input power
			[Nm]	[min ⁻¹]	[kW]	[Nm]	[min ⁻¹]	[kW]	[Nm]	[min ⁻¹]	[kW]	[Nm]	[min ⁻¹]	[kW]	[Nm]	[min ⁻¹]	[kW]
FC- F1C- F2C(F)- F3C-	A15	59	196	295	0.13	196	590	0.26	174	885	0.34	160	1180	0.42	150	1475	0.49
		89	196	445	0.13	174	890	0.23	154	1335	0.30	141	1780	0.37	132	2225	0.43
	A25	29	373	145	0.24	373	290	0.49	373	435	0.73	373	580	0.98	352	725	1.15
		59	460	295	0.30	460	590	0.60	409	885	0.80	376	1180	0.98	351	1475	1.15
		89	460	445	0.30	409	890	0.53	362	1335	0.71	332	1780	0.87	310	2225	1.02
	A35	119	460	595	0.30	375	1190	0.49	332	1785	0.65	304	2380	0.80	285	2975	0.93
		29	657	145	0.43	657	290	0.86	657	435	1.29	657	580	1.72	621	725	2.03
		59	879	295	0.58	879	590	1.15	782	885	1.54	718	1180	1.88	671	1475	2.20
	A45	89	879	445	0.58	781	890	1.02	691	1335	1.36	634	1780	1.66	593	2225	1.94
		119	879	595	0.58	716	1190	0.94	634	1785	1.24	581	2380	1.52	544	2975	1.78
		29	1390	145	0.91	1390	290	1.82	1390	435	2.73	1390	580	3.64	1313	725	4.30
	A65	59	1830	295	1.20	1830	590	2.40	1629	885	3.20	1494	1180	3.91	1397	1475	4.57
		89	1830	445	1.20	1626	890	2.13	1440	1335	2.83	1321	1780	3.46	1235	2225	4.04
		119	1830	595	1.20	1490	1190	1.95	1319	1785	2.59	1210	2380	3.17			
	A75	179	1623	895	1.06	1318	1790	1.72	1167	2685	2.28						
		29	2460	145	1.61	2460	290	3.22	2460	435	4.83	2460	580	6.44	2324	725	7.61
		59	3380	295	2.21	3380	590	4.42	3008	885	5.91	2759	1180	7.22	2581	1475	8.45
	A75	89	3380	445	2.21	3003	890	3.93	2659	1335	5.22	2439	1780	6.39	2281	2225	7.47
		119	3380	595	2.21	2752	1190	3.60	2437	1785	4.79						
		179	2998	895	1.96	2435	1790	3.19									
A75	29	4170	145	2.73	4170	290	5.46	4170	435	8.19	4170	580	10.92	3940	725	12.89	
	59	5140	295	3.36	5140	590	6.73	4574	885	8.98	4196	1180	10.99	3924	1475	12.84	
	89	5140	445	3.36	4567	890	5.98	4044	1335	7.94	3709	1780	9.71				
119	5140	595	3.36	4185	1190	5.48	3706	1785	7.28								

Table A-1 Rating values (reference value output speed n_{2m})

Size	Max. acceleration and deceleration torque T_{2A}	Peak torque for emergency stop T_{2max}^*
	[Nm]	[Nm]
A15	335	785
A25	721	1930
A35	1390	3580
A45	2910	7210
A65	5130	13800
A75	7610	24000

Table A-2 Maximum acceleration and peak torque

* Further limitation by maximum transmittable torque of screw fitting Table A-28, Page 42

30			40			50			60			Max. permissible input speed $n_{1,max}$ short term [min ⁻¹]	Max. permissible input speed $n_{1,ED}$ [min ⁻¹]		Moment of inertia j related to the input shaft [$\times 10^{-4}$ kgm ²]
Nominal output torque [Nm]	Input speed [min ⁻¹]	Max. permissible input power [kW]	Nominal output torque [Nm]	Input speed [min ⁻¹]	Max. permissible input power [kW]	Nominal output torque [Nm]	Input speed [min ⁻¹]	Max. permissible input power [kW]	Nominal output torque [Nm]	Input speed [min ⁻¹]	Max. permissible input power [kW]		50% ED	100% ED	
142	1770	0.56	130	2360	0.68	122	2950	0.80	115	3540	0.90	6150	5600	2800	0.46
125	2670	0.49	115	3560	0.60	107	4450	0.70	102	5340	0.80				
334	870	1.31	306	1160	1.60	286	1450	1.87	271	1740	2.13	4350	3100	1550	
333	1770	1.31	305	2360	1.60	285	2950	1.87	270	3540	2.12				1.42
294	2670	1.15	270	3560	1.41							5050	4200	2100	
269	3570	1.06													
588	870	2.31	539	1160	2.82	504	1450	3.30	477	1740	3.75	3500	2500	1250	
635	1770	2.50	583	2360	3.05	545	2950	3.57							4.58
562	2670	2.21										3950	3300	1650	
1243	870	4.88	1141	1160	5.97	1067	1450	6.98	1010	1740	7.93	2700	1900	950	
1323	1770	5.19	1213	2360	6.35										
1169	2670	4.59													12.7
2201	870	8.64	2019	1160	10.57	1888	1450	12.36				2200	1500	750	
2443	1770	9.59													
3730	870	14.65	3422	1160	17.92							1950	1200	600	
3715	1770	14.59													
												2000	1750	850	110.0

: 50% ED range

: 100% ED range (but max. 10 min. without pause)

- T_{2N} = nominal output torque
Nominal output torque corresponds to the max. permissible average load torque at all output speeds.
The nominal output torque for speeds less than 5 min⁻¹ is equal to the value at 5 min⁻¹.
The value for the maximum permissible input power is calculated from the nominal output torque at 100%.
This value takes the efficiency of Fine Cyclo into consideration.
- $n_{1,max}$ = maximum permissible input speed
However, it must be $n_{1,m}$ (mean input speed) < $n_{1,ED}$.
- $n_{1,ED}$ = permissible input speed according to duty cycle
- T_{2A} = max. Acceleration and braking torque (for fatigue strength at $2 \cdot 10^7$ load cycles)
Permissible peak torque for normal start and stop procedures.
- T_{2max} = max. permissible torque for Emergency Stop situations or in the event of heavy shocks (limited by the mechanical strength)
(permissible 1000 times during the entire lifetime).
- The rated torque T_{2N} is calculated using the following equation when the speed is not shown in the table above:

$$T_{2N} = T_{2N,600} \left(\frac{600}{n_{1m}} \right)^{0.3}$$

T_{2N} : Rated torque at output speed n_{1m}
 $T_{2N,600}$: Rated torque at output speed n_{1m} is 600 min⁻¹

5.2 Torques according to input speeds

Input speed n_{1m} [min ⁻¹]			4000			3000			2500			2000			1750			
Model	Size	Reduction ratio i	Nominal output torque	Output speed	Max. permissible input power	Nominal output torque	Output speed	Max. permissible input power	Nominal output torque	Output speed	Max. permissible input power	Nominal output torque	Output speed	Max. permissible input power	Nominal output torque	Output speed	Max. permissible input power	
			[Nm]	[min ⁻¹]	[kW]	[Nm]	[min ⁻¹]	[kW]	[Nm]	[min ⁻¹]	[kW]	[Nm]	[min ⁻¹]	[kW]	[Nm]	[min ⁻¹]	[kW]	
FC- F1C- F2C(F)- F3C-	A15	59	111	67.8	0.89	121	50.8	0.80	128	42.4	0.71	137	33.9	0.60	142	29.7	0.55	
		89	111	44.9	0.65	121	33.7	0.53	128	28.1	0.47	137	22.5	0.40	142	19.7	0.37	
	A25	29				230	103	3.12	243	86.2	2.74	260	69.0	2.34	270	60.3	2.14	
		59	260	67.8	2.3	284	50.8	1.88	299	42.4	1.6	320	33.9	1.42	333	29.7	1.29	
		89	260	44.9	1.53	284	33.7	1.25	299	28.1	1.10	320	22.5	0.94	333	19.7	0.86	
	A35	119	260	33.6	1.14	284	25.2	0.93	299	21.0	0.82	320	16.8	0.70	333	14.7	0.64	
		29								428	86.2	4.83	458	69.0	4.13	476	60.3	3.76
		59				534	50.8	3.60	573	42.4	3.17	613	33.9	2.71	638	29.7	2.47	
	A45	89				543	33.7	2.39	573	28.1	2.10	613	22.5	1.80	638	19.7	1.64	
		119				543	25.2	1.79	573	21.0	1.57	613	16.8	1.34	638	14.7	1.23	
		29											972	69.0	8.75	1010	60.3	7.97
	A65	59								1190	42.4	6.57	1280	33.9	5.65	1330	29.7	5.13
		89								1190	28.1	4.36	1280	22.5	3.75	1330	19.7	3.40
		119								1190	21.0	3.26	1280	16.8	2.80	1330	14.7	2.55
	A75	179								1190	14.0	2.17	1280	11.2	1.86	1330	9.78	1.69
		29																
		59											2360	33.9	10.40	2459	29.7	9.51
		89											2360	22.5	6.91	2459	19.7	6.30
	A75	119											2360	16.8	5.17	2459	14.7	4.71
		179											2360	11.2	3.44	2459	9.78	3.13
29																		
59															3720	29.7	14.5	
A75	89														3720	19.7	9.58	
	119														3720	14.7	7.16	

Table A-3 Rating values (reference value input speed n_{1m})

Size	Max. acceleration and deceleration torque T_{2A}	Peak torque for emergency stop T_{2max}^*
	[Nm]	[Nm]
A15	335	785
A25	721	1930
A35	1390	3580
A45	2910	7210
A65	5130	13800
A75	7610	24000

Table A-4 Maximum acceleration and peak torque

* Further limitation by maximum transmittable torque of screw fitting Table A-28, Page 42

1500			1000			750			< 600			Max. permissible input speed $n_{1,max}$ short term [min ⁻¹]	Max. permissible input speed $n_{1,ED}$ [min ⁻¹]		Moment of inertia j related to the input shaft [$\times 10^{-4}$ kgm ²]
Nominal output torque [Nm]	Output speed [min ⁻¹]	Max. permissible input power [kW]	Nominal output torque [Nm]	Output speed [min ⁻¹]	Max. permissible input power [kW]	Nominal output torque [Nm]	Output speed [min ⁻¹]	Max. permissible input power [kW]	Nominal output torque [Nm]	Output speed [min ⁻¹]	Max. permissible input power [kW]		50% ED	100% ED	
149	25.4	0.50	168	16.9	0.37	183	12.7	0.30	196	10.10	0.26	6150	5600	2800	0.46
149	16.9	0.33	168	11.2	0.25	183	8.4	0.20	196	6.74	0.17	6150			
283	51.7	1.92	320	34.5	1.44	349	25.9	1.18	373	20.70	1.00	4350	3100	1550	
349	25.4	1.16	395	16.9	0.87	430	12.7	0.71	460	10.10	0.61	5050			1.42
349	16.9	0.77	395	11.2	0.58	430	8.4	0.47	460	6.74	0.41	5050	4200	2100	
349	12.6	0.77	395	8.4	0.43	430	6.3	0.35	460	5.04	0.30	5050			
499	51.7	3.38	564	34.5	2.54	615	25.9	2.08	657	20.70	1.78	3500	2500	1250	
668	25.4	2.22	754	16.9	1.76	822	12.7	1.27	879	10.10	1.17	3950			4.58
668	16.9	1.47	754	11.2	1.11	822	8.4	0.91	879	6.74	0.77	3950	3300	1650	
668	12.6	1.10	754	8.4	0.83	822	6.3	0.68	879	5.04	0.58	3950			
1060	51.7	7.16	1190	34.5	5.39	1300	25.9	4.41	1390	20.70	3.77	2700	1900	950	
1390	25.4	4.60	1570	16.9	3.48	1710	12.7	2.84	1830	10.10	2.43	3150			12.7
1390	16.9	3.05	1570	11.2	2.30	1710	8.4	1.88	1830	6.74	1.61	3150	2600	1300	
1390	12.6	2.28	1570	8.4	1.72	1770	6.3	1.41	1830	5.04	1.20	3150			
1390	8.38	1.51	1570	5.59	1.15	1710	4.2	0.93	1830	3.35	0.80	3150			
1870	51.7	12.70	2110	34.5	9.50	2300	25.9	7.79	2460	20.70	6.66	2200	1500	750	
2570	25.4	8.54	2900	16.9	6.43	3160	12.7	5.25	3380	6.74	2.98	2350			49.5
2570	16.9	5.66	2900	11.2	4.26	3160	8.43	3.48	3380	5.04	2.23	2350	2000	1000	
2570	12.6	4.23	2900	8.4	3.19	3160	6.3	2.6	3380	5.04	2.23	2350			
2570	8.38	2.81	2900	5.59	2.12	3160	4.19	1.73	3380	3.35	1.48	2350			
			3580	34.5	16.10	3900	25.9	13.2	4170	20.70	11.30	1950	1200	600	
3900	25.4	13.00	4410	16.9	9.76	4810	12.7	7.99	5140	10.10	6.83	2000			110.0
3900	16.9	8.60	4410	11.2	6.47	4810	8.43	5.29	5140	6.74	4.53	2000	1750	850	
3900	12.6	6.43	4410	8.4	4.84	4810	6.3	3.96	5140	5.0	3.39	2000			

: 50% ED range

: 100% ED range (but max. 10 min. without pause)

- T_{2N} = nominal output torque
Nominal output torque corresponds to the max. permissible average load torque at all input speeds.
The nominal output torque for speeds less than 600 min⁻¹ is equal to the value at 600 min⁻¹.
The value for the maximum permissible input power is calculated from the nominal output torque at 100%.
This value takes the efficiency of Fine Cyclo into consideration.
- $n_{1,max}$ = maximum permissible input speed
However, it must be n_{1m} (mean input speed) < $n_{1,ED}$.
- $n_{1,ED}$ = permissible input speed according to duty cycle
- T_{2A} = max. Acceleration and braking torque (for fatigue strength at $2 \cdot 10^7$ load cycles)
Permissible peak torque for normal start and stop procedures.
- T_{2max} = max. permissible torque for Emergency Stop situations or in the event of heavy shocks (limited by the mechanical strength)
(permissible 1000 times during the entire lifetime).
- The rated torque T_{2N} is calculated using the following equation when the speed is not shown in the table above:

$$T_{2N} = T_{2N,600} \left(\frac{600}{n_{1m}} \right)^{0.3}$$

T_{2N} : Rated torque at input speed n_{1m}
 $T_{2N,600}$: Rated torque at input speed n_{1m} is 600 min⁻¹

5.3 Stiffness and Lost Motion

Size	i	Test torque T_p [Nm]	Lost Motion		Torsional stiffness 3% - 50% T_p [Nm/arcmin]	Torsional stiffness 3% - 100% T_p [Nm/arcmin]	Torsional stiffness 50% - 100% T_p [Nm/arcmin]
			Lost Motion [arcmin]	Domain of definition [Nm]			
A15	59	±149	< 2 arcmin standard	±4.5	15 (14)	20 (18)	28 (24)
	89				15 (14)	20 (18)	28 (24)
A25	29	±349		±11	40 (37)	53 (47)	80 (70)
	59				52 (46)	70 (60)	100 (81)
	89			52 (46)	70 (60)	100 (81)	
A35	119	±668		±20	52 (46)	70 (60)	100 (81)
	29				70 (65)	95 (85)	140 (120)
	59				110 (95)	145 (120)	210 (161)
	89			110 (95)	145 (120)	210 (161)	
A45	119	±1390		±42	110 (95)	145 (120)	210 (161)
	29				170 (155)	220 (195)	300 (255)
	59				220 (195)	300 (225)	445 (350)
	89				220 (195)	300 (225)	445 (350)
	119			220 (195)	300 (225)	445 (350)	
A65	179	±2570	±77	220 (195)	300 (225)	445 (350)	
	29			310 (285)	400 (360)	530 (460)	
	59			400 (360)	530 (460)	770 (627)	
	89			400 (360)	530 (460)	770 (627)	
	119			400 (360)	530 (460)	770 (627)	
A75	179	±3900	±117	400 (360)	530 (460)	770 (627)	
	29			590 (530)	740 (650)	960 (810)	
	59			610 (550)	790 (685)	1100 (910)	
	89			610 (550)	790 (685)	1100 (910)	
	119			610 (550)	790 (685)	1100 (910)	

Table A-5 Torsional stiffness

(...) Values in brackets apply for F3C-A

T_p : Test torque at input speed $n_1 = 1500 \text{ min}^{-1}$

Calculation of the twist angle:

1) At a load torque less than 3% T_p

$$\varphi = \frac{\text{Lost Motion}}{2} \cdot \frac{\text{Load torque}}{0.03 \cdot T_p}$$

2) At a load torque greater than 3% T_p (standard case)

$$\varphi = \frac{\text{Lost Motion}}{2} + \frac{\text{Load torque} - (0.03 \cdot T_p)}{\text{Torsional stiffness}}$$

Note arcmin means “angular minute”.
Table values for stiffness are average values.

Sold & Serviced By:



Toll Free Phone (877) SERV098
www.electromate.com
sales@electromate.com

5.4 No-load running torque NLRT

No-load running torque for i = 59, 89, and 119

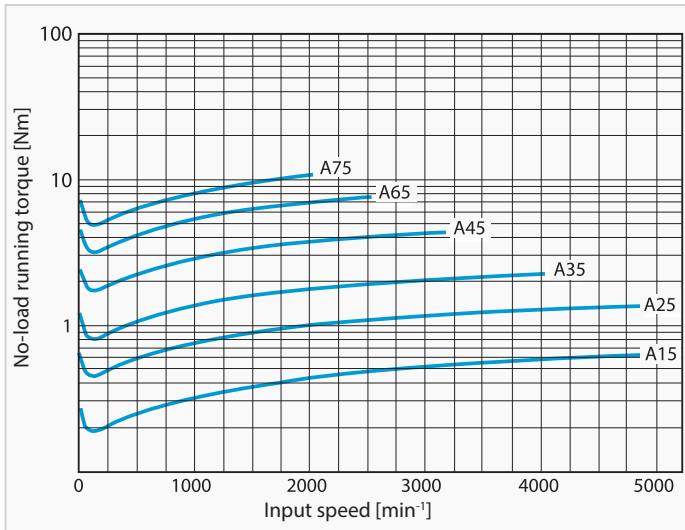

Fig. A-1 Input side no-load running torque (i 59-119)

No-load running torque for i = 29

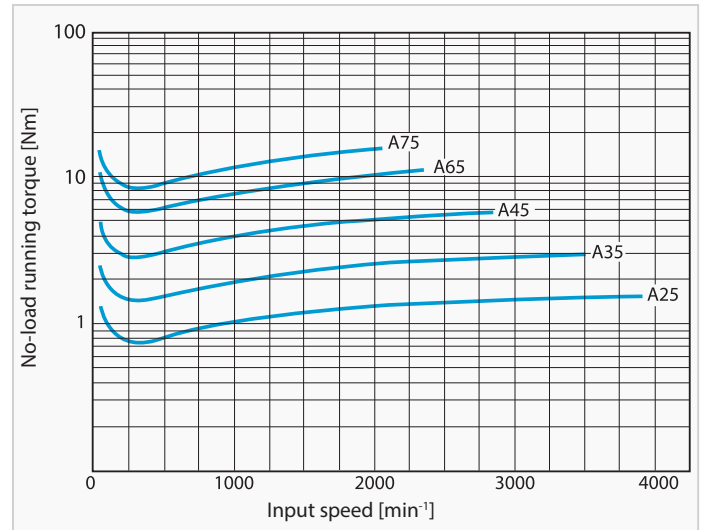

Fig. A-2 Input side no-load running torque (i 29)

- Note**
1. Fig. A-1 and Fig. A-2 show the average no-load running torques after gearbox is run in (not new condition).
 2. Table A-6 shows the measuring conditions.

5.5 Breakaway torque

Breakaway torque on output side (BTO)

- Note**
1. Table A-7 shows the max. breakaway torque on the output side BTO. Fine Cyclo gearboxes are not self-locking. The BTO is defined as the maximum value (factory-new condition), which steadily decreases during the lifetime.
 2. Table A-6 shows the measuring conditions.

Ring gear housing temperature	approx. 30 °C
Precision during assembly	as per chapter 5.9.1, 5.10.1, 5.11.1, 5.12.1
Lubrication	Standard lubrication

Table A-6 Measurement conditions

Size	Breakaway torque BTO [Nm]
A15	< 75
A25	< 180
A35	< 245
A45	< 360
A65	< 530
A75	< 700

Table A-7 Value of the breakaway torque on the output side (BTO)

Sold & Serviced By:
 **ELECTROMATE**
 Toll Free Phone (877) SERV098
www.electromate.com
sales@electromate.com

Breakaway torque on input side (BTI)

Note

1. Table A-8 shows the max. breakaway torque BTI on the input side. BTI is defined as the maximum value (factory-new condition) which steadily decreases during the lifetime.
2. Table A-6 shows the measuring conditions

Size	i	Breakaway torque BTI [Nm]
A15	59	< 1
	89	< 0.8
A25	29	< 5.6
	59	< 2.8
	89	< 2.45
A35	119	< 1.9
	29	< 7
	59	< 2.8
A45	89	< 2.0
	119	< 2
	29	< 8
A65	59	< 4.3
	89	< 3.15
	119	< 2
	179	< 1.8
A75	29	< 9
	59	< 5
	89	< 4.5
	119	< 3.8
A75	179	< 2.6
	29	< 20
	59	< 6.5
A75	89	< 5.5
	119	< 4.5

Table A-8 Value of the breakaway torque on the input side (BTI)

5.6 Efficiency

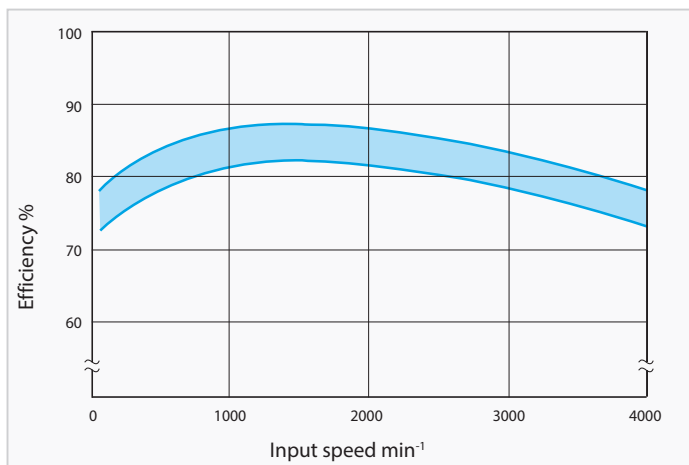

Fig. A-3 Efficiency curve

Fig. A-3 shows the correlation between efficiency and input speed. For further information, see "4 Description of technical specifications for cycloidal gearboxes" on page 22.

Note

1. The efficiency changes if the load torque does not match the nominal torque. Check the compensation factor in the diagram Fig. A-4.
2. When the torque ratio is over 1.0, the compensation factor for efficiency is 1.0 (diagram Fig. A-4).

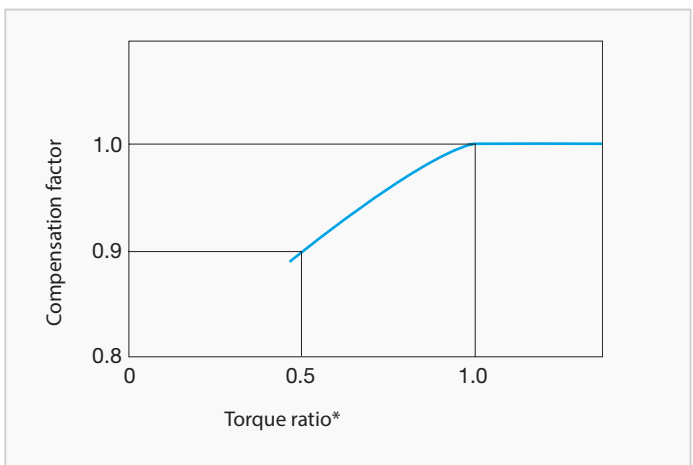

Fig. A-4 Compensation curve for efficiency

$$* \text{ Torque ratio} = \frac{\text{Load torque}}{\text{Nominal output torque}}$$

$$\text{Compensation efficiency} = \text{efficiency} \cdot \text{compensation factor}$$

5.7 Bearing loads

5.7.1 Maximum permissible radial and axial load on the input shaft

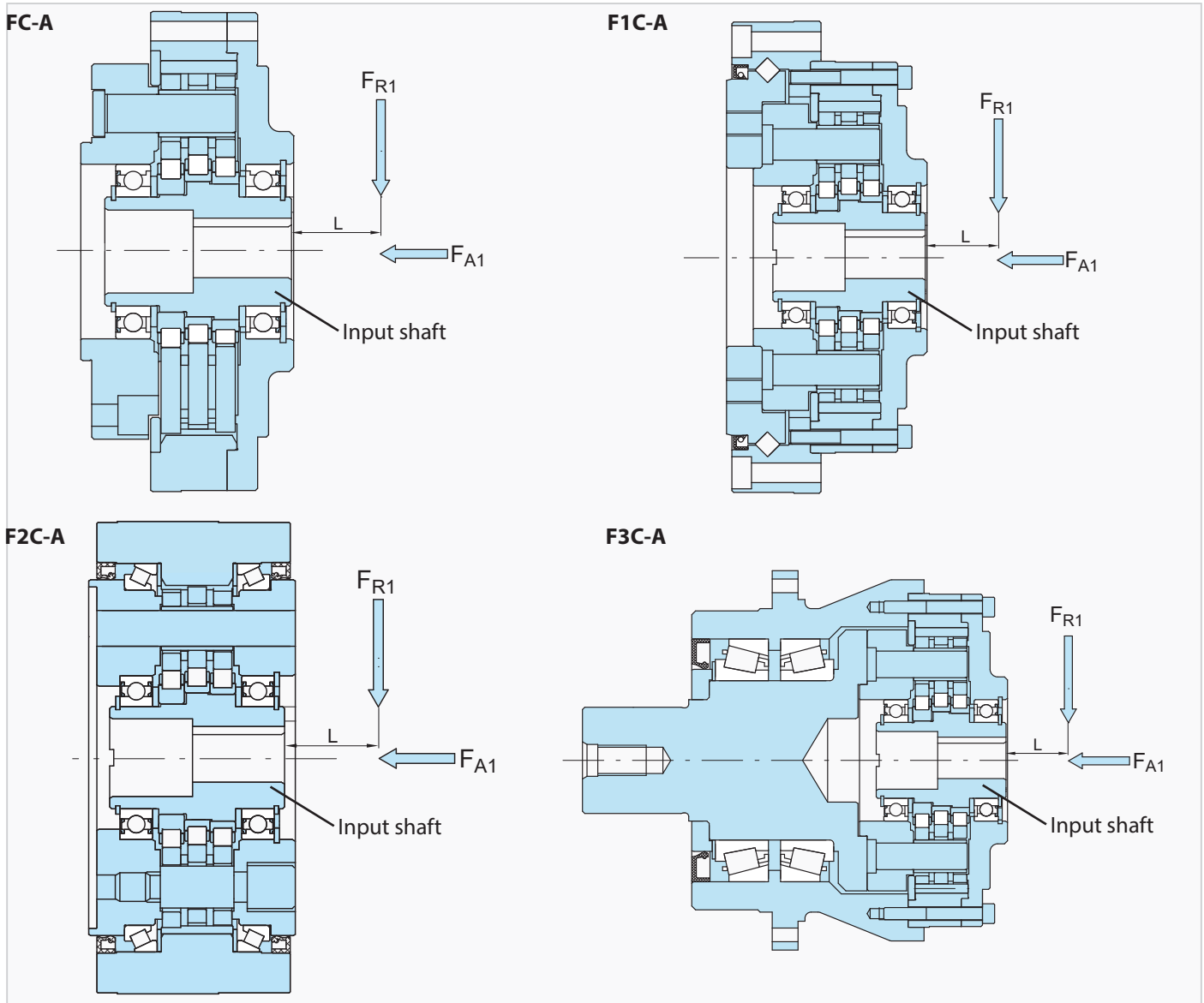

Fig. A-5 Load position on input shaft

If a gear or timing belt pulley is mounted on the input shaft, the values for radial load and axial load should be equal to or less than the permissible values. The following equation is used to check whether the shaft load is permissible:

1. Input radial load F_{R1}

$$F_{R1} = 10^3 \cdot \frac{T_{2V}}{\eta \cdot i \cdot r_0} \leq \frac{F_{R1 \max}}{L_{f1} \cdot C_{f1} \cdot B_{f1}} \quad [\text{N}] \quad (\text{Equation A-1})$$

2. Input side axial load F_{A1}

$$F_{A1} \leq \frac{F_{A1 \max}}{C_{f1} \cdot B_{f1}} \quad [\text{N}] \quad (\text{Equation A-2})$$

3. When radial and axial loads co-exist

$$\left(\frac{F_{R1} \cdot L_{f1}}{F_{R1 \max}} + \frac{F_{A1}}{F_{A1 \max}} \right) \cdot C_{f1} \cdot B_{f1} \leq 1 \quad (\text{Equation A-3})$$

F_{R1} = input side radial load [N]

T_{2V} = reference torque on output shaft [Nm]

r_0 = pitch circle radius of sprocket, pinion, or timing belt pulley [mm]

$F_{R1 \max}$ = maximum permissible input side radial load [N] (Table A-9)

F_{A1} = input side axial load [N]

$F_{A1 \max}$ = max. permissible input side axial load [N] (Table A-10)

L_{f1} = load factor input (Table A-11)

C_{f1} = correction factor input (Table A-12)

B_{f1} = service factor input (Table A-13)

L = distance of radial load from front end on input side of the input shaft [mm] (Table A-11)

η = 0.8 (efficiency)

Size	Input speed n_{1m} [min ⁻¹]								
	4000	3000	2500	2000	1750	1500	1000	750	600
A15	225	245	255	275	295	300	350	390	410
A25	330	360	390	420	440	460	530	580	628
A35		490	520	560	590	620	700	780	835
A45			610	660	690	720	820	900	980
A65				880	930	980	1120	1240	1320
A75					1180	1240	1410	1560	1670

Table A-9 Max. permissible input side radial load $F_{R1\ max}$ [N]

$$F_{R1\ max} = F_{R1,600} \left(\frac{600}{n_{1m}} \right)^{1/3}$$

$F_{R1\ max}$ = maximum permissible input side radial load at input speed n_{1m}

$F_{R1,600}$ = Radial load on input side at input speed $n_{1m} = 600\ \text{min}^{-1}$

L [mm]	Load factor input L_{fi}					
	Size					
	A15	A25	A35	A45	A65	A75
10	0.90	0.86				
15	0.98	0.93	0.91			
20	1.25	1.00	0.96	0.86		
25	1.56	1.25	1.09	0.94		
30	1.88	1.50	1.30	0.99	0.89	0.89
35	2.19	1.75	1.52	1.13	0.93	0.92
40		2.00	1.74	1.29	0.97	0.96
45			1.96	1.45	1.02	0.99
50			2.17	1.61	1.14	1.09
60				1.94	1.36	1.30
70					1.59	1.52
80					1.82	1.74

Table A-11 Load factor input L_{fi}

L = Distance from input side input shaft front end

Size	Input speed n_{1m} [min ⁻¹]								
	4000	3000	2500	2000	1750	1500	1000	750	600
A15	245	285	315	345	360	390	470	550	610
A25	360	410	450	500	540	580	700	805	880
A35		600	650	725	765	825	1000	1100	1100
A45			1010	1120	1200	1290	1290	1290	1290
A65				1440	1440	1440	1440	1440	1440
A75					2120	2280	2770	3170	3210

Table A-10 Max. permissible input side axial load $F_{A1\ max}$ [N]

$$F_{A1\ max} = F_{A1,600} \left(\frac{600}{n_{1m}} \right)^{0.47}$$

$F_{A1\ max}$ = maximum permissible input side axial load at input speed n_{1m}

$F_{A1,600}$ = Axial load on input side at input speed $n_{1m} = 600\ \text{min}^{-1}$

Correction factor input	C_{fi}
Chain	1
Gear or pinion *	1.25
Timing belt	1.25
V-Belt	1.5

Table A-12 Correction factor input C_{fi}

* For helical pinions or bevel gears, please consult Sumitomo Drive Technologies.

Service factor input	B_{fi}
Uniform load	1
Light impacts	1.2
Severe impacts	1.6

Table A-13 Service factor input B_{fi}

Sold & Serviced By:



Toll Free Phone (877) SERV098
www.electromate.com
sales@electromate.com

5.7.2 Main bearing

Fine Cyclo - F1C-A

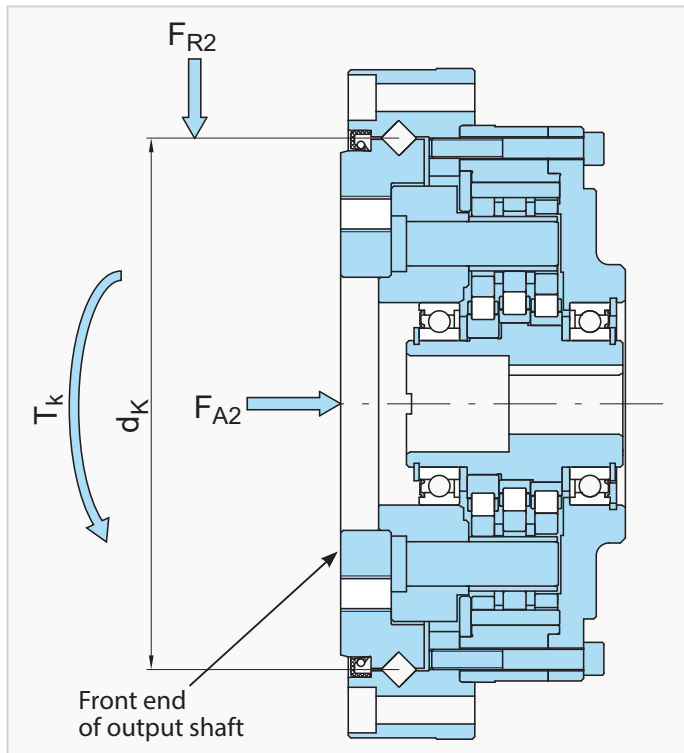

Fig. A-6 Load position output

For power transmission by means of pinion, timing belt, or similar:

$$F_{R2} = C_{f2} \cdot B_{f2} \cdot \frac{2 \cdot 10^3 \cdot T_{2v}}{d_0} \quad \text{(Equation A-9)}$$

Size	Θ_1 [Nm/arcmin]	$T_{k \max}$ [Nm]	d_k [mm]	C [N]	C_0 [N]
A15	205	460	101	26700	25400
A25	370	770	123	29600	31000
A35	750	1350	149	62300	64500
A45	3500	3350	210	81000	159000
A65	7800	6700	279	170000	325000
A75	15600	14400	340	263000	510000

Table A-14 Specification cross roller bearings

1. Moment stiffness

The moment stiffness is the bending moment at which the output flange is tilted by the tilt angle.

The tilt angle of the output flange is determined as follows:

$$\varphi_1 = \frac{T_k}{\Theta_1} \quad \text{(Equation A-5)}$$

	Load factor	
	Radial load X_L	Axial load Y_L
$\frac{F_{A2}}{F_{R2} + \frac{2 \cdot 10^3 \cdot T_k}{d_k}} \leq 1.5$	1	0.45
$\frac{F_{A2}}{F_{R2} + \frac{2 \cdot 10^3 \cdot T_k}{d_k}} > 1.5$	0.67	0.67

- F_{A2} = output side axial load [N]
- F_{R2} = output side radial load [N]
- C_{f2} = correction factor output
- B_{f2} = service factor output
- d_k = Mean bearing diameter [mm]
- $T_{k \max}$ = maximum permissible bending moment [Nm]
- T_k = bending moment [Nm]
- φ_1 = tilt angle [arcmin]
- Θ_1 = moment stiffness main bearing [Nm/arcmin]
- T_{2v} = reference torque [Nm]
- d_0 = pitch circle diameter of output element [mm]
- C = dynamic load rating
- C_0 = static load rating
- P = equivalent load

Correction factor	C_{f2}
Chain	1
Gear or pinion	1.25
Timing belt	1.25
V-Belt	1.5

Table A-15 Correction factor output C_{f2}

Service factor	B_{f2}
Uniform load	1
Light impacts	1.2
Severe impacts	1.6

Table A-16 Service factor output B_{f2}

A dynamically equivalent load P on the bearing is calculated from these loads.

With the equivalent load P and the mean input speed n_{2m} , it is possible to test whether the output bearing achieves the desired lifetime L_{h10} .

$$P = X_L \left(F_{R2} + \frac{2 \cdot 10^3 \cdot T_k}{d_k} \right) + Y_L \cdot F_{A2} \quad \text{(Equation A-10)}$$

$$L_{h10} = \frac{10^6}{60 \cdot n_{2m}} \left(\frac{C}{P} \right)^{\frac{10}{3}} \quad \text{(Equation A-11)}$$

Fine Cyclo - F2C(F)

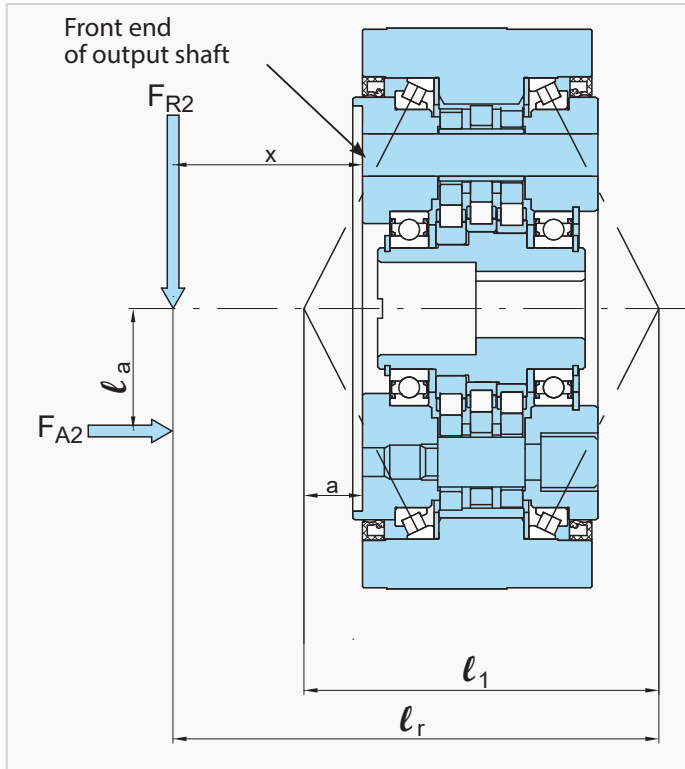

Fig. A-7 Distance between the individual loading points

$$l_r = x - a + l_1 \quad \text{(Equation A-4)}$$

1. Moment stiffness

The moment stiffness is the bending moment at which the output flange is tilted by the tilt angle.

The tilt angle of the input flange is determined as follows:

$$\varphi_1 = \frac{T_k}{\Theta_1} \quad \text{(Equation A-5)}$$

External bending moment T_k

$$T_k = 10^{-3} \cdot (F_{R2} \cdot l_r + F_{A2} \cdot l_a) \quad \text{(Equation A-6)}$$

2. Max. permissible bending moment and max. permissible axial load.

Check the equivalent bending moment and the equivalent axial load using equations A-6, A-7, A-8, and Fig. A-8.

Equivalent bending moment T_{ke}

$$T_{ke} = 10^{-3} \cdot (C_{f2} \cdot B_{f2} \cdot F_{R2} \cdot l_r + C_{f2} \cdot B_{f2} \cdot F_{A2} \cdot l_a) < T_{kmax} \quad \text{(Equation A-7)}$$

Equivalent axial load F_{A2e} at the output shaft

$$F_{A2e} = F_{A2} \cdot C_{f2} \cdot B_{f2} < F_{A2max} \quad \text{(Equation A-8)}$$

Size	Values of internal bearing distance	
	l_1 [mm]	a [mm]
A15	72.6	6.5
A25	80.4	8.7
A35	108.0	14.5
A45	139.2	20.6

Table A-17 Bearing clearances

Note If: $l_r > 4 \cdot l_1$, please contact Sumitomo Drive Technologies.

- F_{A2} = output side axial load [N]
- F_{A2max} = maximum permissible output side axial load [N]
- F_{A2e} = equivalent output side axial load [N]
- F_{R2} = output side radial load [N]
- C_{f2} = correction factor output (Table A-18)
- B_{f2} = service factor output (Table A-19)
- l_1 = bearing clearance [mm] (Table A-17)
- l_r = calculated dimension for bending moment [mm]
- l_a = distance of axial load [mm]
- x = distance from radial force to flange collar [mm]
- a = correction factor [mm] (Table A-17)
- T_k = external bending moment [Nm]
- T_{kmax} = maximum permissible bending moment [Nm] (Table A-20)
- T_{ke} = equivalent bending moment [Nm]
- φ_1 = tilt angle [arcmin]
- Θ_1 = moment stiffness main bearing [Nm/arcmin] (Table A-21)

Correction factor output	C_{f2}
Chain	1
Gear or pinion	1.25
Timing belt	1.25
V-Belt	1.5

Table A-18 Correction factor output C_{f2}

Service factor output	B_{f2}
Uniform load	1
Light impacts	1.2
Severe impacts	1.6

Table A-19 Service factor output B_{f2}

Size	Max. permissible bending moment T_{kmax}	Max. permissible axial load F_{A2max}	
		Tension	Compression
	[Nm]	[N]	[N]
A15	608	2450	3920
A25	1030	3920	5400
A35	1620	5400	7850
A45	2550	6870	11800

Table A-20 Max. permissible bending moment and max. permissible axial load

Size	Moment stiffness Θ_1
	[Nm/arcmin]
A15	230
A25	400
A35	950
A45	1600

Table A-21 Average values for moment stiffness

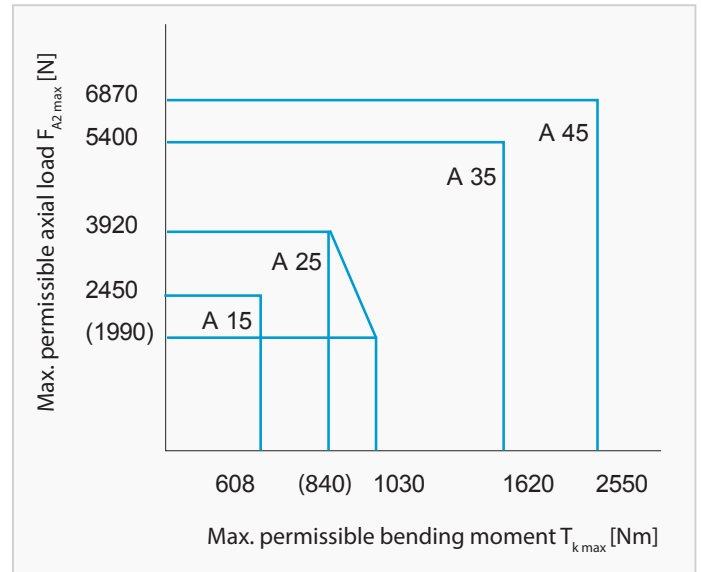

Fig. A-8 Max. permissible bending moment and axial load

Fine Cyclo - F3C-A

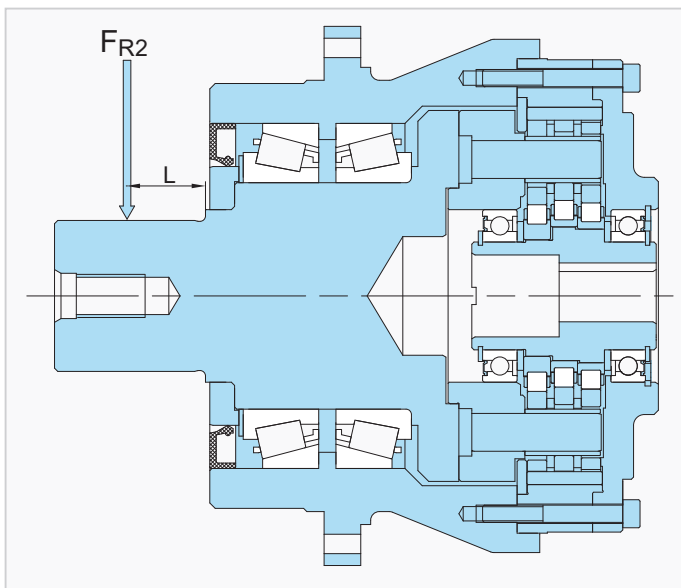

Fig. A-9 Load position output

If the output shaft is fitted with a pinion or a disc, a force acts on the shaft. The following equation is used to check whether the shaft load is permissible.

Radial load F_{R2} [kN]

$$F_{R2} = \frac{T_{2V} \cdot L_f \cdot B_f \cdot C_{f2}}{r_0} \leq F_{R2per} \quad \text{(Equation A-12)}$$

Radial load

- F_{R2zul} = permissible radial load [kN]
- T_{2V} = reference torque [Nm]
- L_f = load factor
- B_f = service factor
- C_{f2} = correction factor
- r_0 = pitch circle radius of the pinion [mm]

Correction factor output	C_{fz}
Chain	1
Gear or pinion	1.25
Timing belt	1.25
V-Belt	1.5

Table A-22 Correction factor output C_{fz}

Service factor output	B_{fz}
Uniform load	1
Light impacts	1.2
Severe impacts	1.6

Table A-23 Service factor output B_{fz}

n_{2m} [rpm]	Permissible radial load F_{R2zul} [kN] for F3C-					
	A15	A25	A35	A45	A65	A75
~ 5	17.4	31.8	44.4	87.9	126	157
10	17.4	31.8	44.4	81.2	114	153
15	17.4	31.8	44.4	71.7	114	135
20	17.4	31.8	44.4	65.6	104	124
25	17.4	31.8	41.1	61.2	97.5	115
30	17.4	29.8	38.8	57.9	92.5	109
35	17.4	28.4	37.0	55.2	88.2	104
40	17.4	27.3	35.5	52.9	84.6	100
50	17.4	25.4	33.2	49.4	78.9	93.5
60	17.4	24.1	31.3	46.6		
80		22.0				

Table A-24 Permissible radial load F_{R2zul}

L [mm]	Load factor L_{fz} for F3C-					
	A15	A25	A35	A45	A65	A75
10	0.91	0.86				
15	0.97	0.92	0.88	0.85		
20	1.03	0.97	0.93	0.88	0.84	
25	1.09	1.03	0.98	0.92	0.88	0.86
30	1.16	1.08	1.02	0.98	0.91	0.89
35	1.22	1.14	1.07	1.00	0.94	0.92
40		1.19	1.12	1.04	0.97	0.95
45		1.25	1.16	1.08	1.00	0.97
50			1.21	1.12	1.03	1.00
60				1.19	1.09	1.05
70				1.27	1.16	1.11
80					1.22	1.16
90					1.28	1.22
100						1.27

Table A-25 Load factor L_{fz}

5.8 Lubrication

- The gearboxes of the Fine Cyclo A-series are filled with grease before delivery and are ready to use.
- Reconditioning is recommended after 20,000 operating hours, but at least every 3-5 years.
- The lifetime of the gearbox can be increased by returning it to the factory for overhauling and regreasing.

Specified grease	Manufacturer
CITRAX FA NO. 2	Kyodo Yushi Co., Ltd.
Conditions for use: Ambient temperature -10 °C to +40 °C	

Table A-26 Specified grease for the A Series

Sold & Serviced By:

 Toll Free Phone (877) SERV098
www.electromate.com
sales@electromate.com

5.9 Model FC-A

5.9.1 Assembly tolerances

In order for the thrust washer to be held by the customer's housing, the internal diameter B must not exceed the specified values. The depth of the output shaft spigot must be equal to or less than dimension "D" to prevent jamming the output flange. Furthermore, dimension "E" must be adhered to. The recommended accuracy of the assembly part (housing and output shaft) must lie within coaxiality "k" and parallelism "p".

The recommended diameters of the centerings of the housing, output shaft, and input side flange are shown schematically below.

To ensure the function, lifetime, and characteristics of the gearbox, the radial run-out of the shaft ends, the coaxiality and the axial run-out of the fastening surface as per EN 50347:2001 are sufficient.

When used in high-precision applications, the tolerance according to EN 50347:2001 should be reduced by 50%, which has additional advantages.

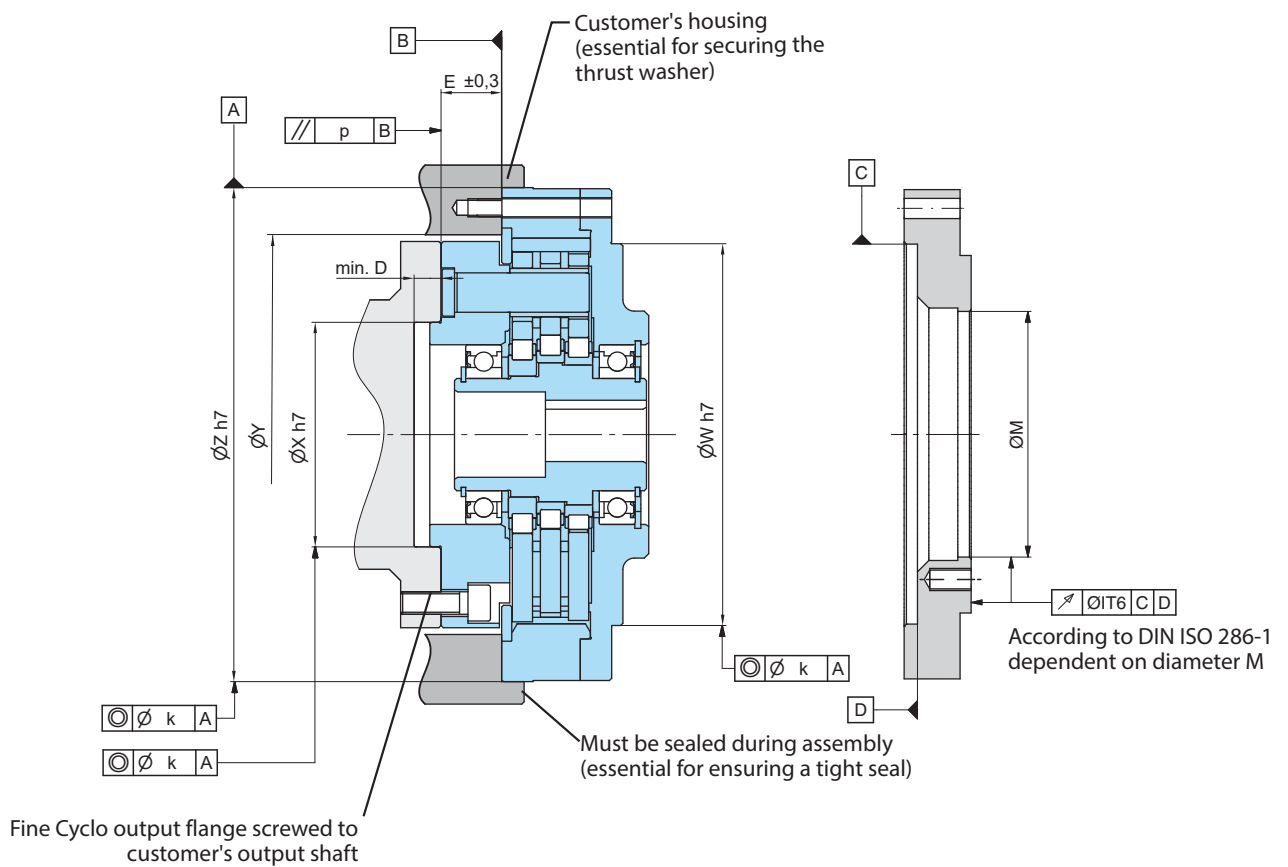

Size	Ø M	Ø X	Ø Y min.	Ø Y max.	Ø Z	Ø W	D	E	k	p
A15	 Motor centering	45	89	90	115	85	5	15.5	0.030	0.025
A25		60	114	115	145	110	6	21	0.030	0.035
A35		80	139	144	180	135	6	24	0.030	0.040
A45		100	174	182	220	170	8	27	0.030	0.050
A65		130	214	226	270	210	8	33	0.030	0.065
A75		150	239	262	310	235	8	38	0.030	0.070

Table A-27 (Dimensions in mm)

5.9.2 Tightening torque and maximum permissible transmittable torque for bolts

The permissible transmitted torque for bolts and the number, size, and tightening torque for fastening the output side flange and the ring gear housing are listed in Table A-28. In the event of an Emergency Stop with corresponding load peaks, the output flange and ring gear housing bolts must all be replaced.

Size	Output flange bolts		Bolts for ring gear (housing)		Max. permissible transmittable torque for bolts [Nm]
	Number and size of bolts	Tightening torque [Nm]	Number and size of bolts	Tightening torque [Nm]	
A15	12 × M5	9.2	8 × M5	9.2	470
A25	12 × M6	16	8 × M6	16	830
A35	12 × M8	39	8 × M8	39	1900
A45	12 × M10	77	12 × M8	39	3550
A65	12 × M12	135	12 × M10	77	7000
A75	12 × M12	135	12 × M10	77	8000

Table A-28

- **Bolting:** Use metric hexagon socket head screws (DIN 4762, strength category 12.9).
- **Countermeasure for bolts loosening:** Use adhesives (Loctite 262, etc.) or spring washer (DIN 127A).
- **Use spring washers** (DIN 6796) when connecting the gearbox to the flange side, so that the bolt contact faces do not get damaged.

Sold & Serviced By:



Toll Free Phone (877) SERV098
www.electromate.com
sales@electromate.com

5.9.3 Installation example

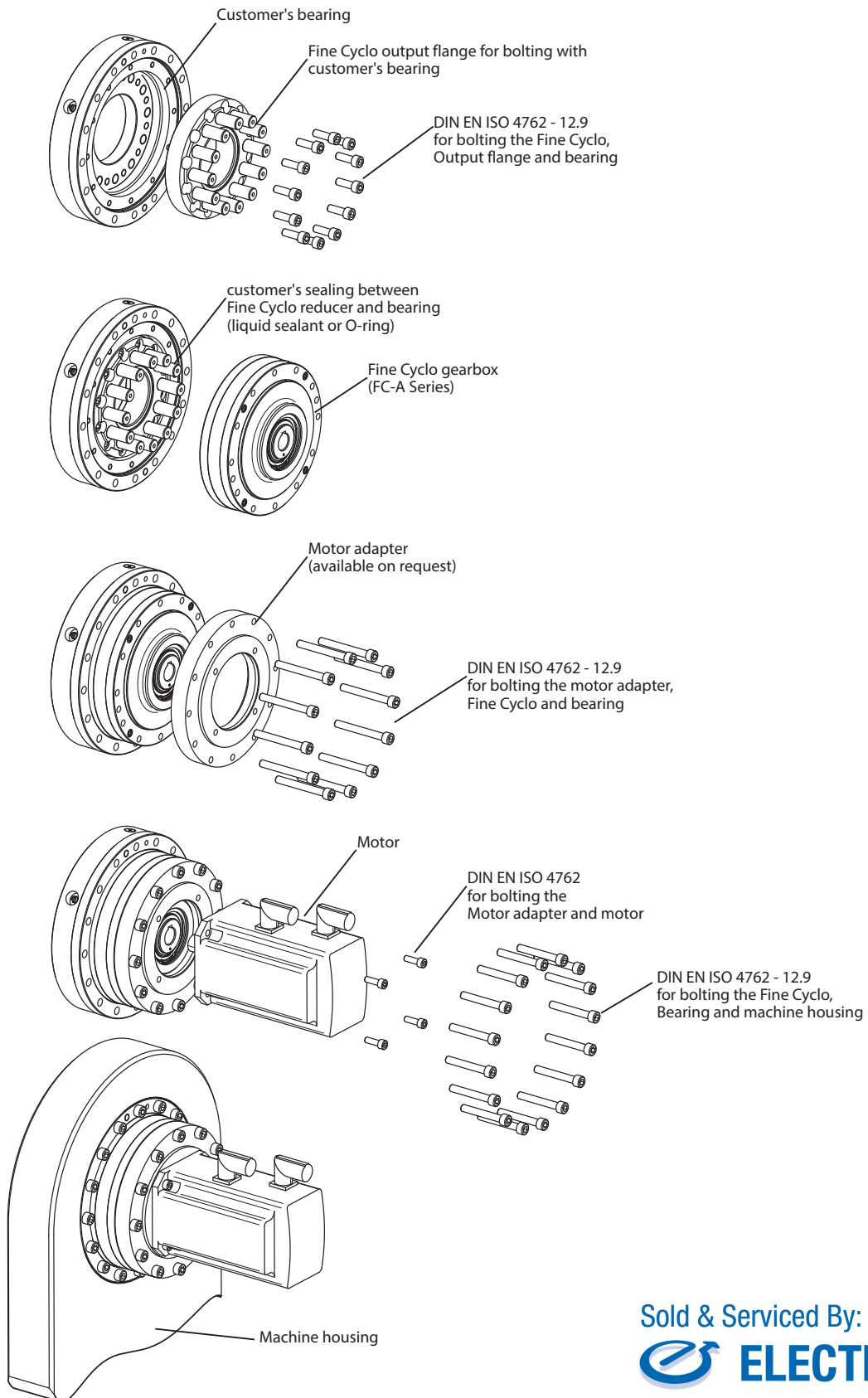

Sold & Serviced By:

 **ELECTROMATE**

Toll Free Phone (877) SERV098
www.electromate.com
sales@electromate.com

5.9.4 Dimensioned drawings

FC-A15G

Mass 2.7 kg

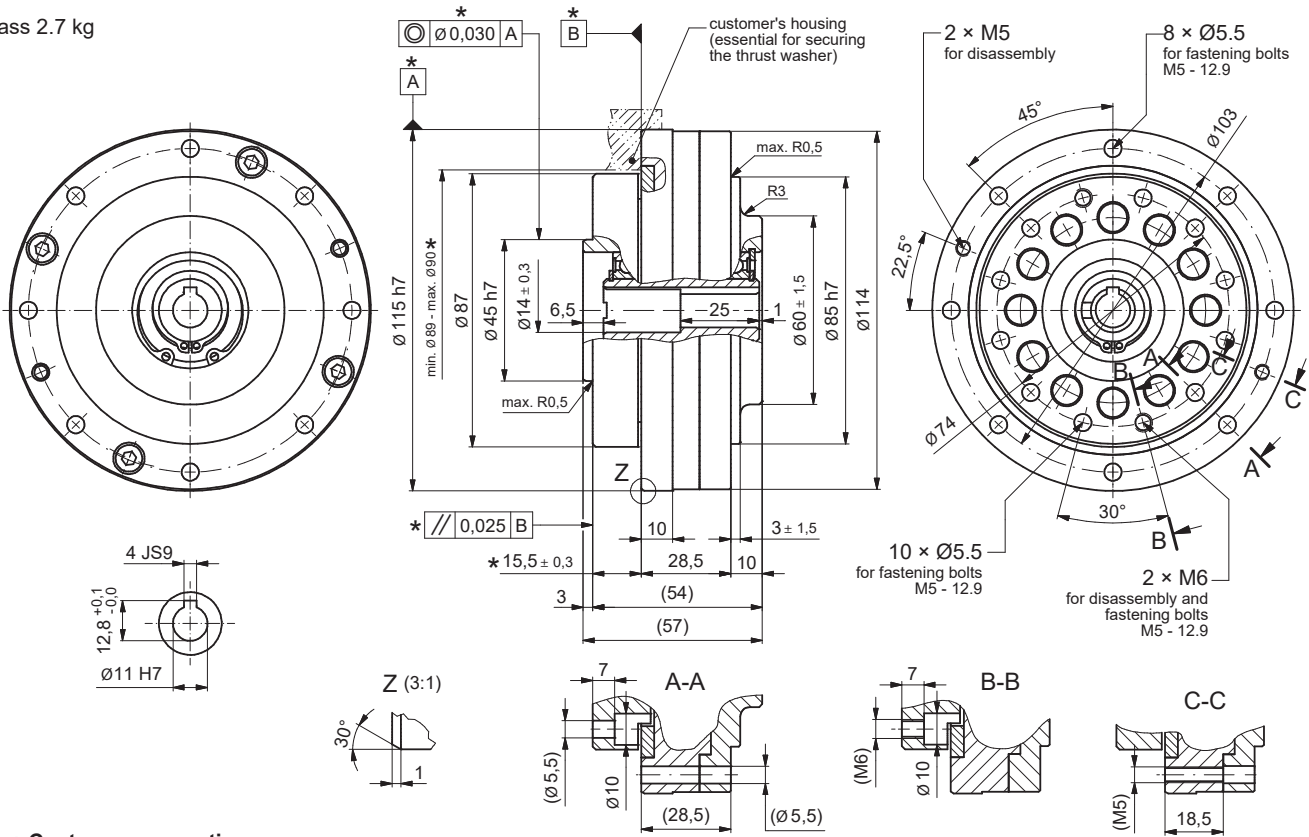

*** Customer connection**

Connection tolerances and connection dimensions of the customer
See also "5.9.1 Assembly tolerances" on page 41

FC-A25G

Mass 5.2 kg

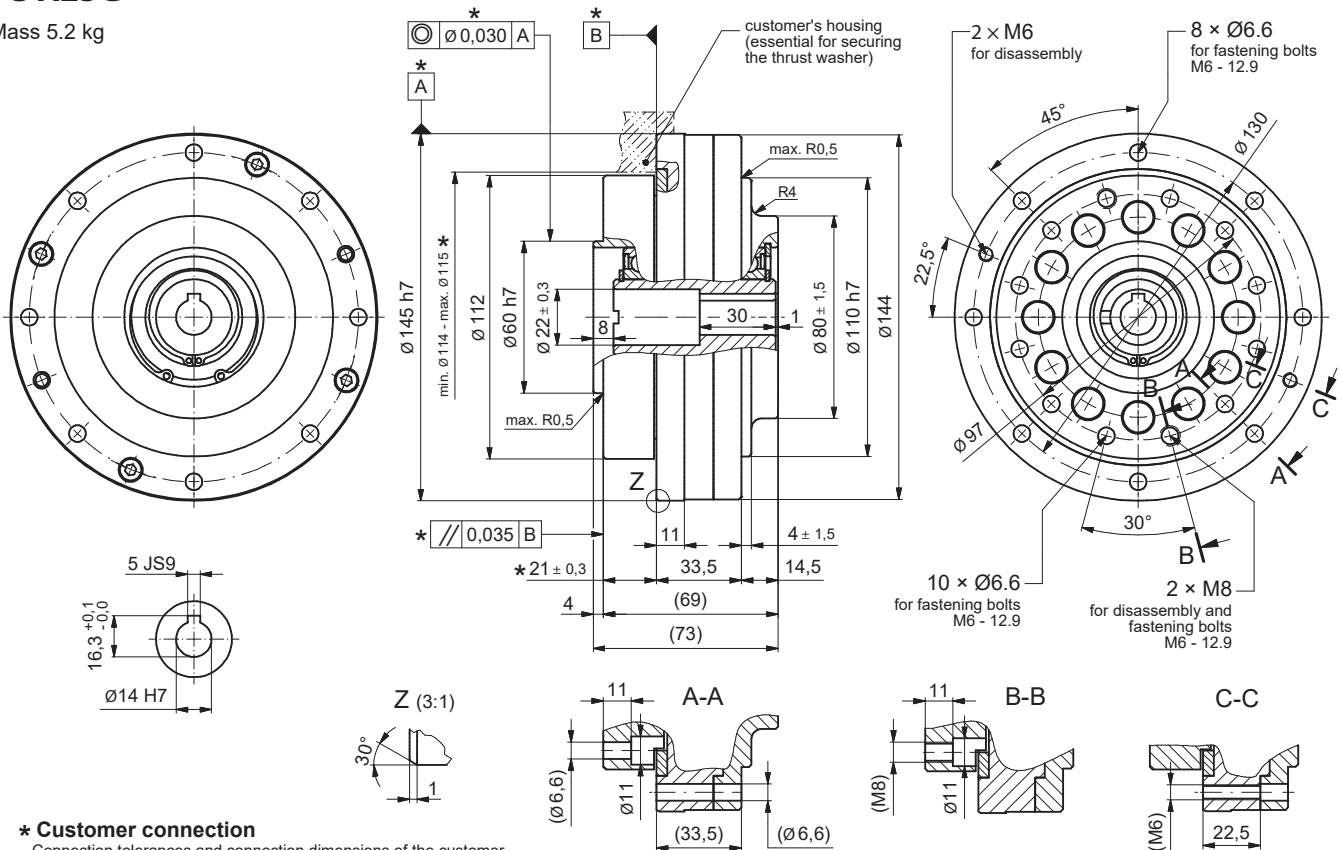

*** Customer connection**

Connection tolerances and connection dimensions of the customer
See also "5.9.1 Assembly tolerances" on page 41

FC-A35G

Mass 9.6 kg

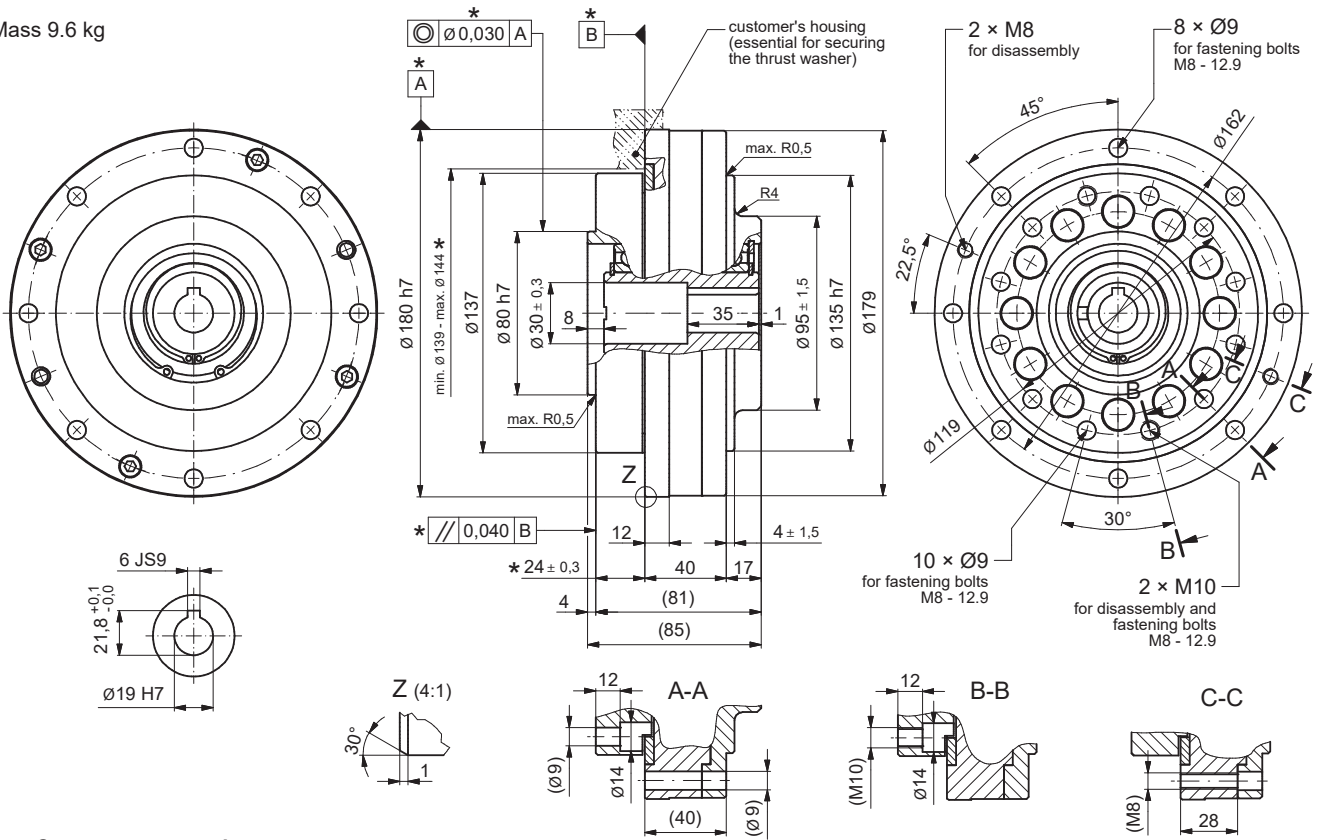

*** Customer connection**

Connection tolerances and connection dimensions of the customer
See also "5.9.1 Assembly tolerances" on page 41

FC-A45G

Mass 18 kg

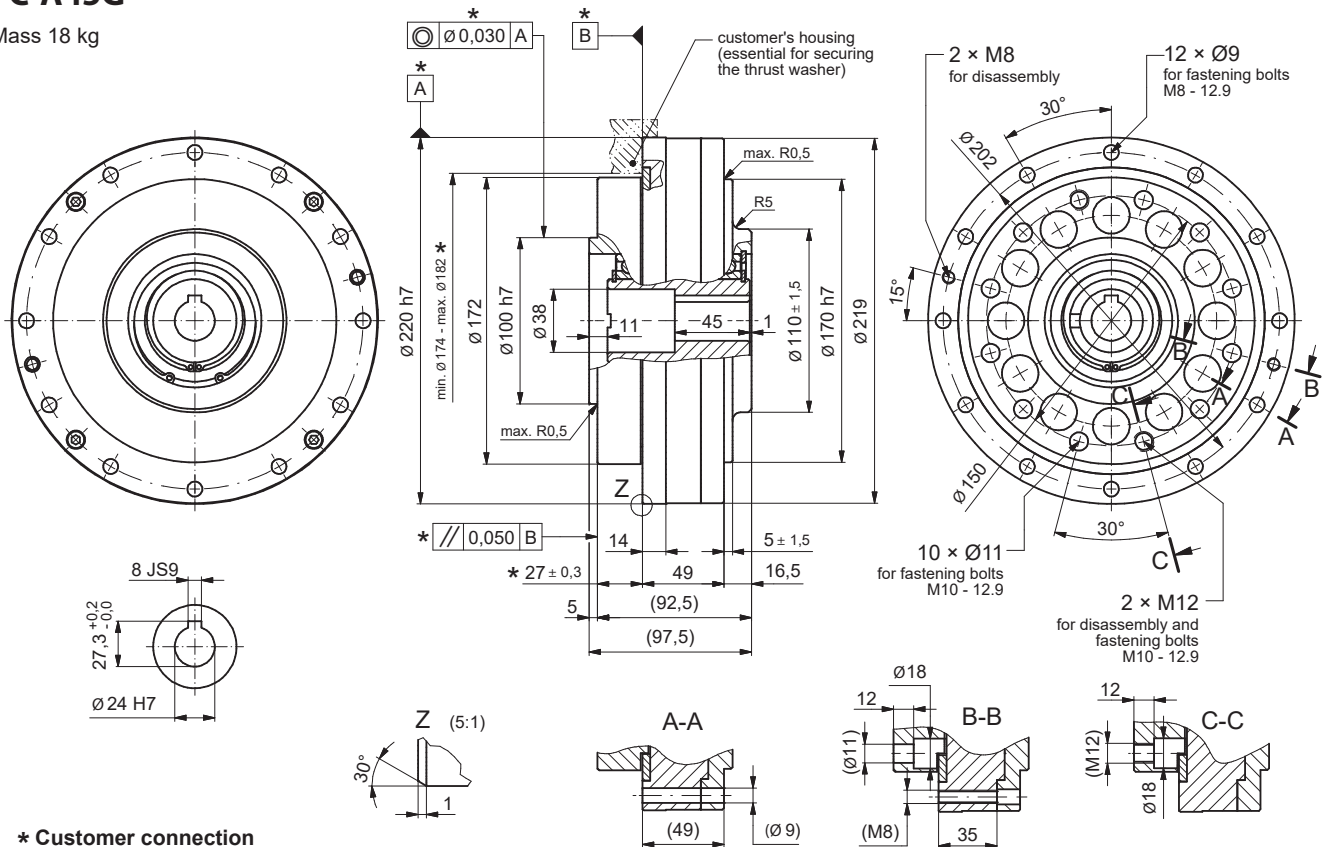

*** Customer connection**

Connection tolerances and connection dimensions of the customer
See also "5.9.1 Assembly tolerances" on page 41

FC-A65G

Mass 30 kg

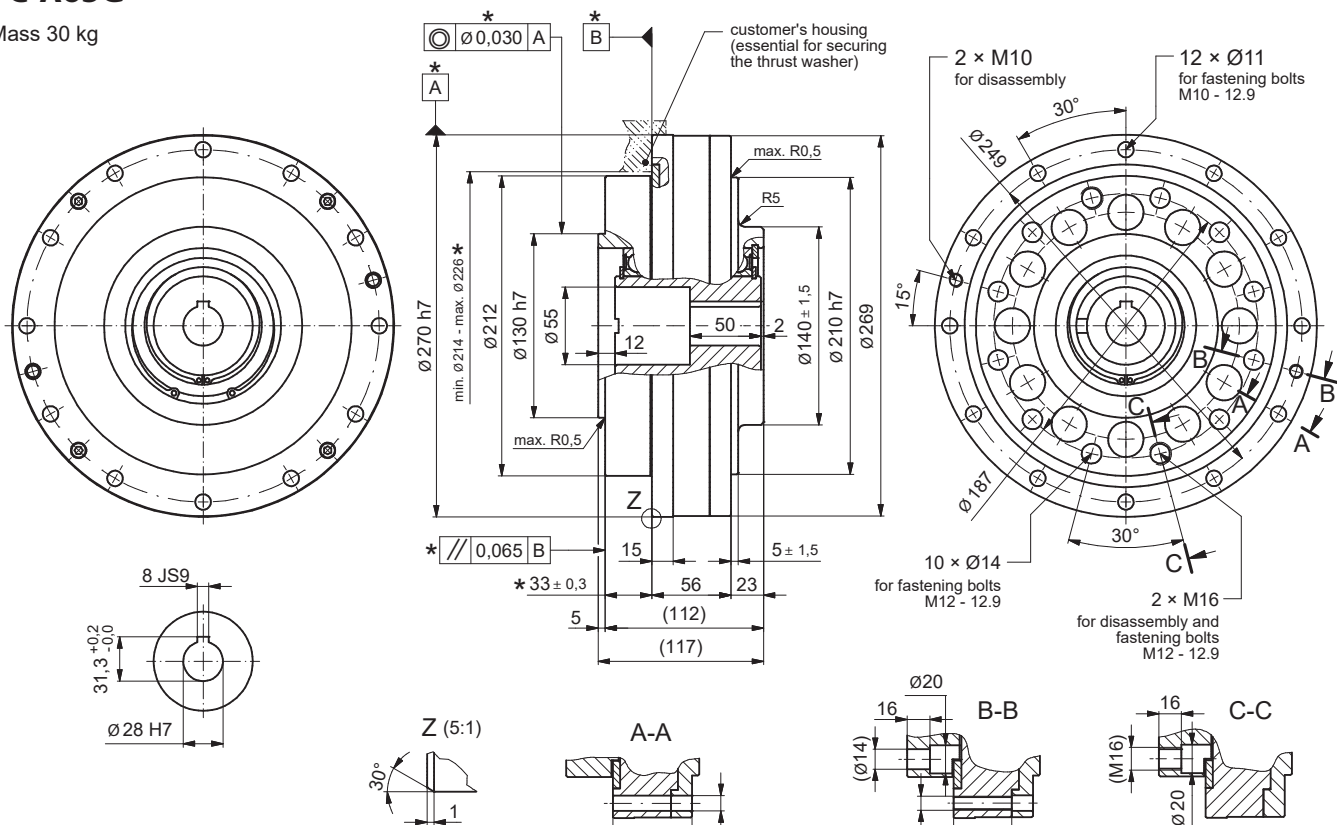

*** Customer connection**

Connection tolerances and connection dimensions of the customer
See also "5.9.1 Assembly tolerances" on page 41

FC-A75G

Mass 46 kg

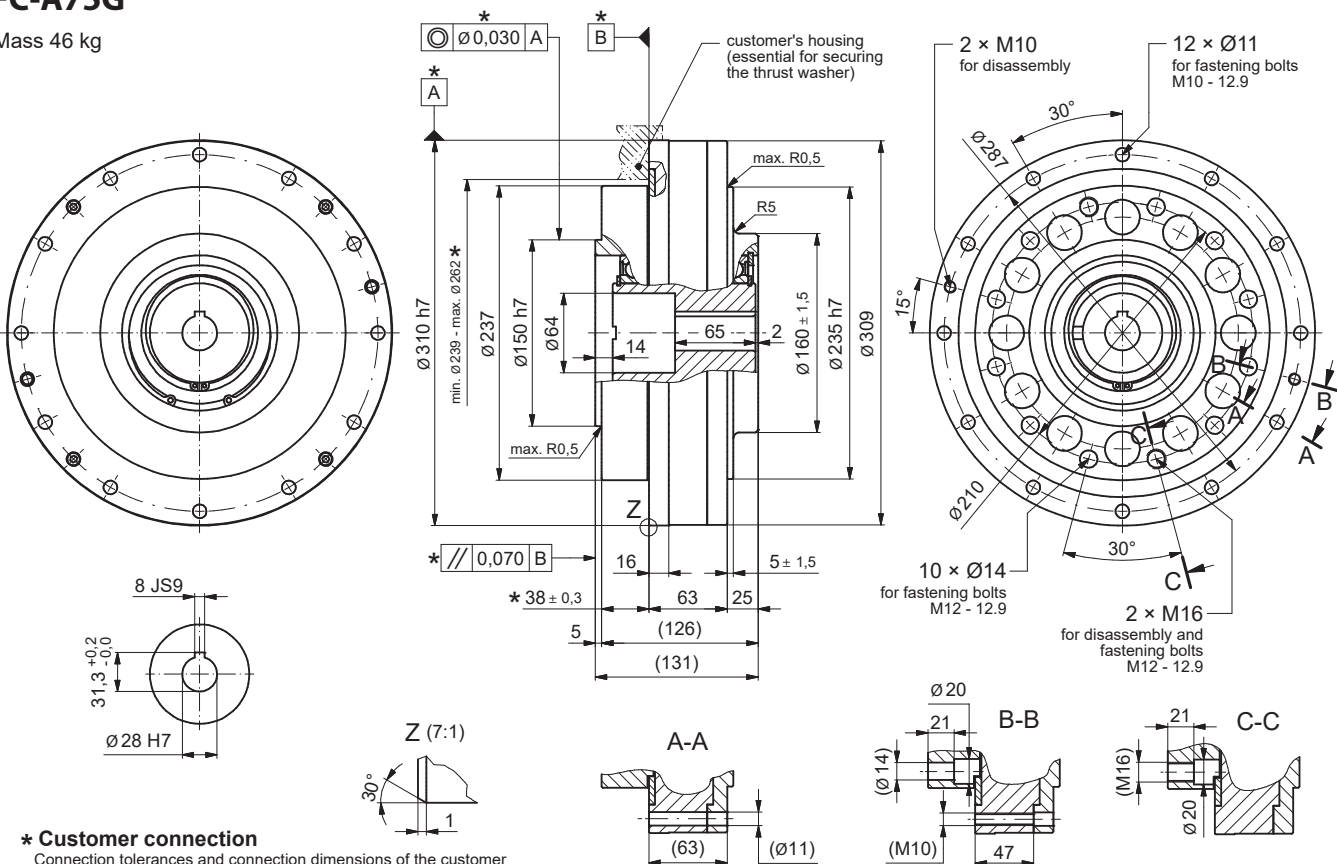

*** Customer connection**

Connection tolerances and connection dimensions of the customer
See also "5.9.1 Assembly tolerances" on page 41

5.10 Model F1C-A

5.10.1 F1C-A assembly tolerances

To ensure the function, lifetime, and characteristics of the gearbox, the radial run-out of the shaft ends, the coaxiality and the axial run-out of the fastening surface as per EN 50347:2001 are sufficient. When used in high-precision applications, the tolerance according to EN 50347:2001 should be reduced by 50%, which has additional advantages.

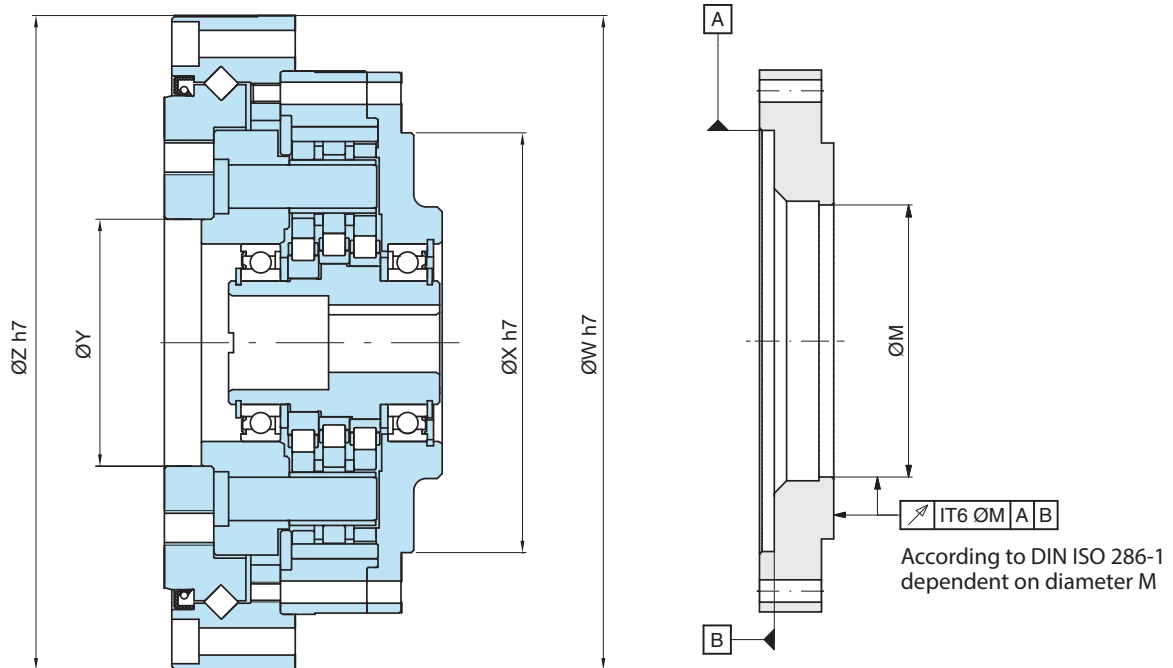

Size	Ø X	Ø Y	Ø Z	Ø W	Ø M
A15	85	45 h7	140		 Motor centering
A25	110	60 h7	170		
A35	135	80 h7	205		
A45	170	100 M7		265	
A65	210	130 M7		350	
A75	235	150 M7		430	

Table A-29 (Dimensions in mm)

5.10.2 Tightening torque and maximum permissible transmittable torque for bolts

The permissible transmitted torque for bolts and the number, size, and tightening torque for fastening the output side flange and the ring gear housing are listed in Table A-30. In the event of an Emergency Stop with corresponding load peaks, the output flange and ring gear housing bolts must all be replaced.

Size	Output flange bolts		Bolts for ring gear (housing)		Max. permissible transmittable torque for bolts [Nm]
	Number and size of bolts	Tightening torque [Nm]	Number and size of bolts	Tightening torque [Nm]	
A15	12 × M6	16	12 × M6	16	750
A25	12 × M8	39	12 × M8	39	1700
A35	12 × M10	77	12 × M10	77	3150
A45	12 × M14	210	16 × M10	77	3550
A65	16 × M16	330	20 × M12	135	7000
A75	16 × M16	330	20 × M12	135	8000

Table A-30

- **Bolting:** Use metric hexagon socket head screws (DIN 4762, strength category 12.9).
- **Countermeasure for bolts loosening:** Use adhesives (Loctite 262, etc.) or spring washer (DIN 127A).
- **Use spring washers** (DIN 6796) when connecting the gearbox to the flange side, so that the bolt contact faces do not get damaged.

5.10.3 Installation example

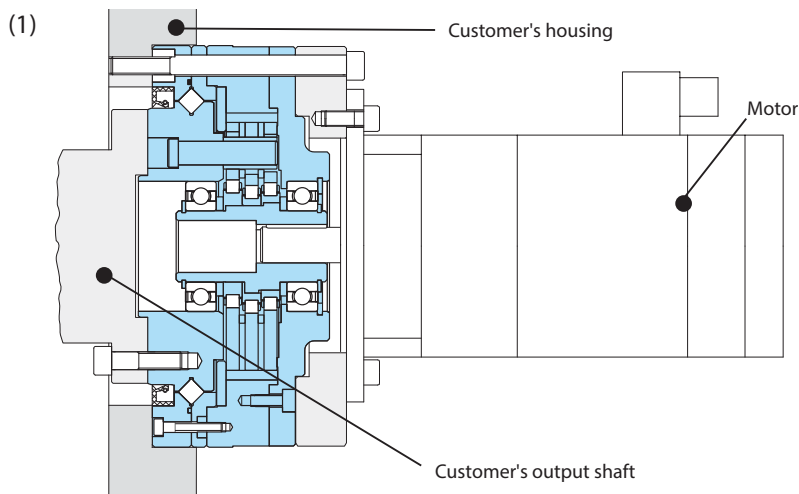

The motor is connected via an intermediate flange with the Fine Cyclo F1C-A gearbox and bolted onto the customer's housing.

The customer's output shaft is bolted to the output flange of the gearbox.

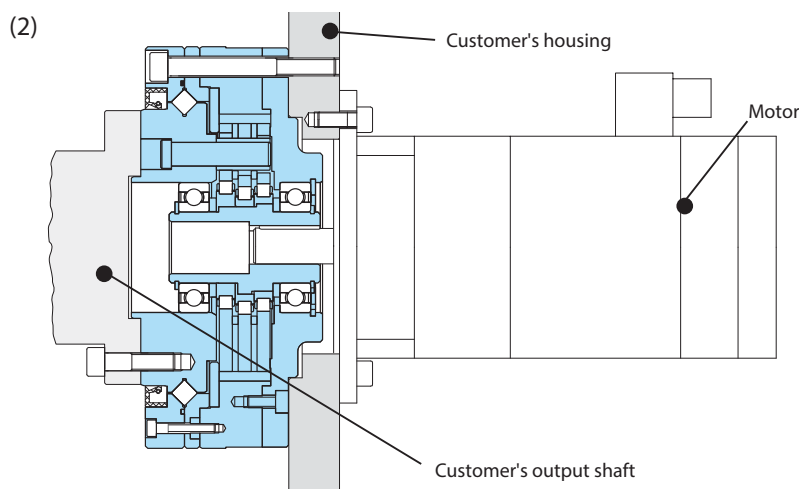

The motor and the Fine Cyclo F1C-A gearbox are both bolted onto the customer's housing.

The customer's output shaft is bolted to the output flange of the gearbox.

5.10.4 Lubrication

- The cross roller bearings of the F1C- gearboxes, sizes A45, A65 and A75, are also suitable for all mounting positions, but require regreasing after 4,000 operating hours or at least every 6 months.
- For information on regreasing quantities for the cross roller bearings and on grease types, see Table A-31.

Size	Quantity of grease [g]	Manufacturer	Grease type
A45	~10 - 15	SHELL	GADUS S2 V220 2
A65	~25 - 30		
A75	~45 - 50		

Table A-31 Lubrication

5.10.5 Dimensioned drawings

F1C-A15

Mass 6.0 kg

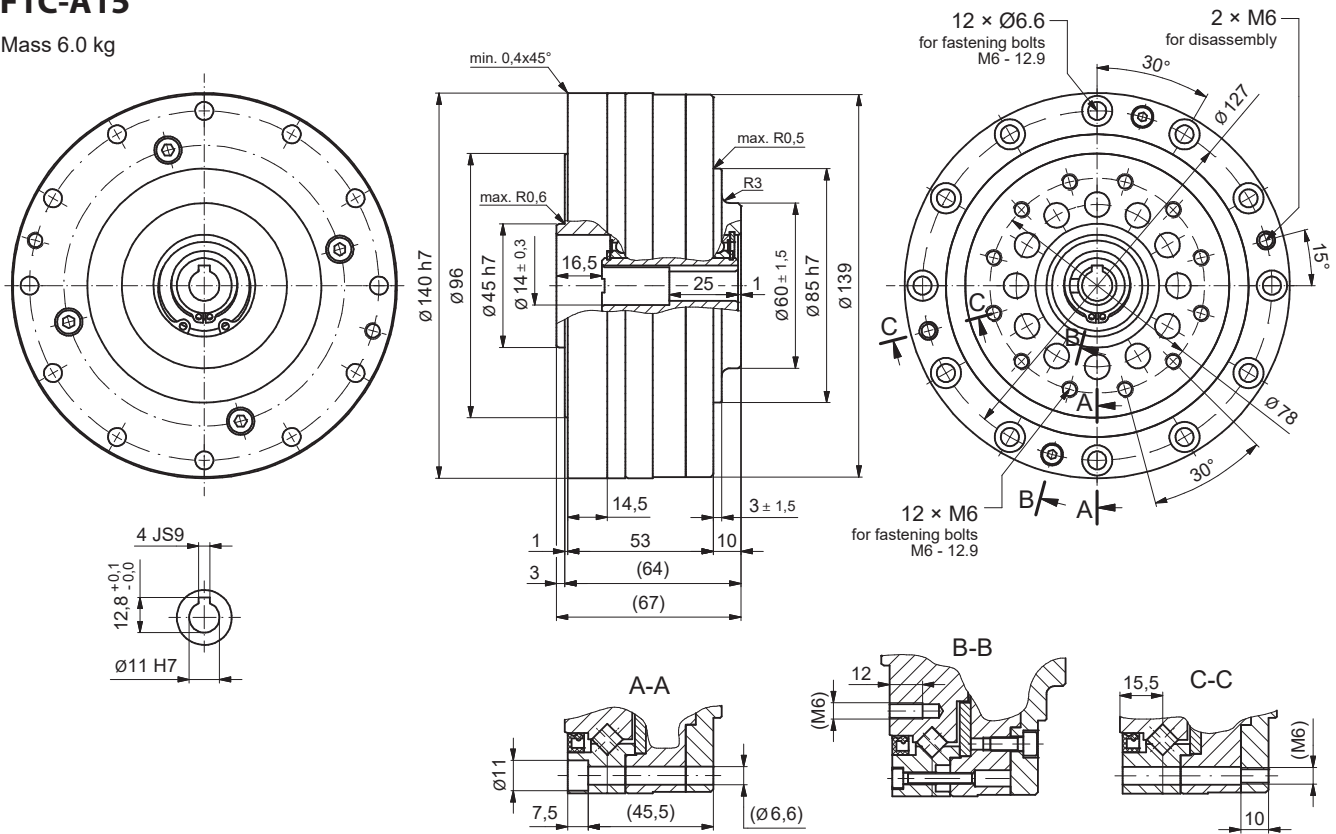

F1C-A25

Mass 9.5 kg

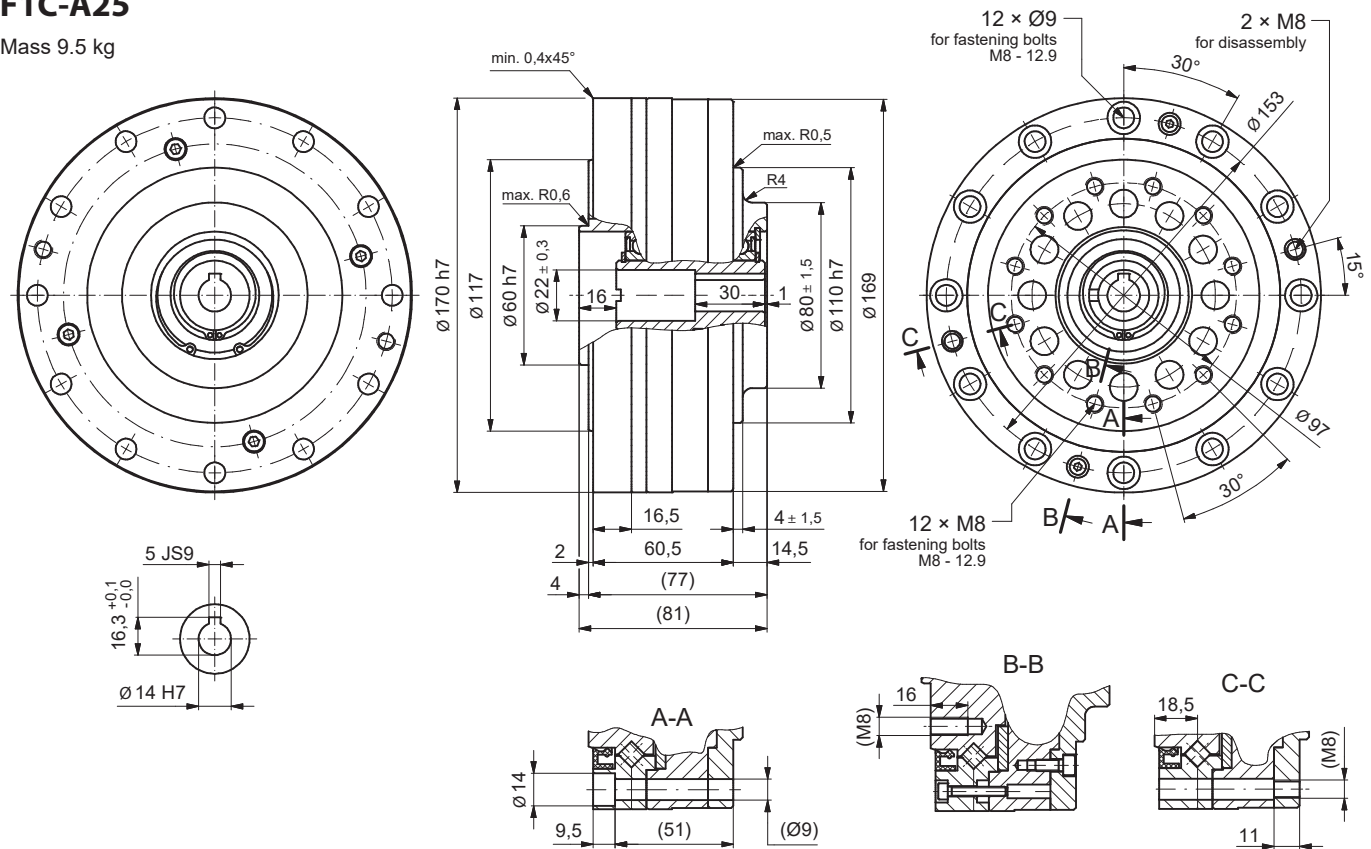

F1C-A35

Mass 16.5 kg

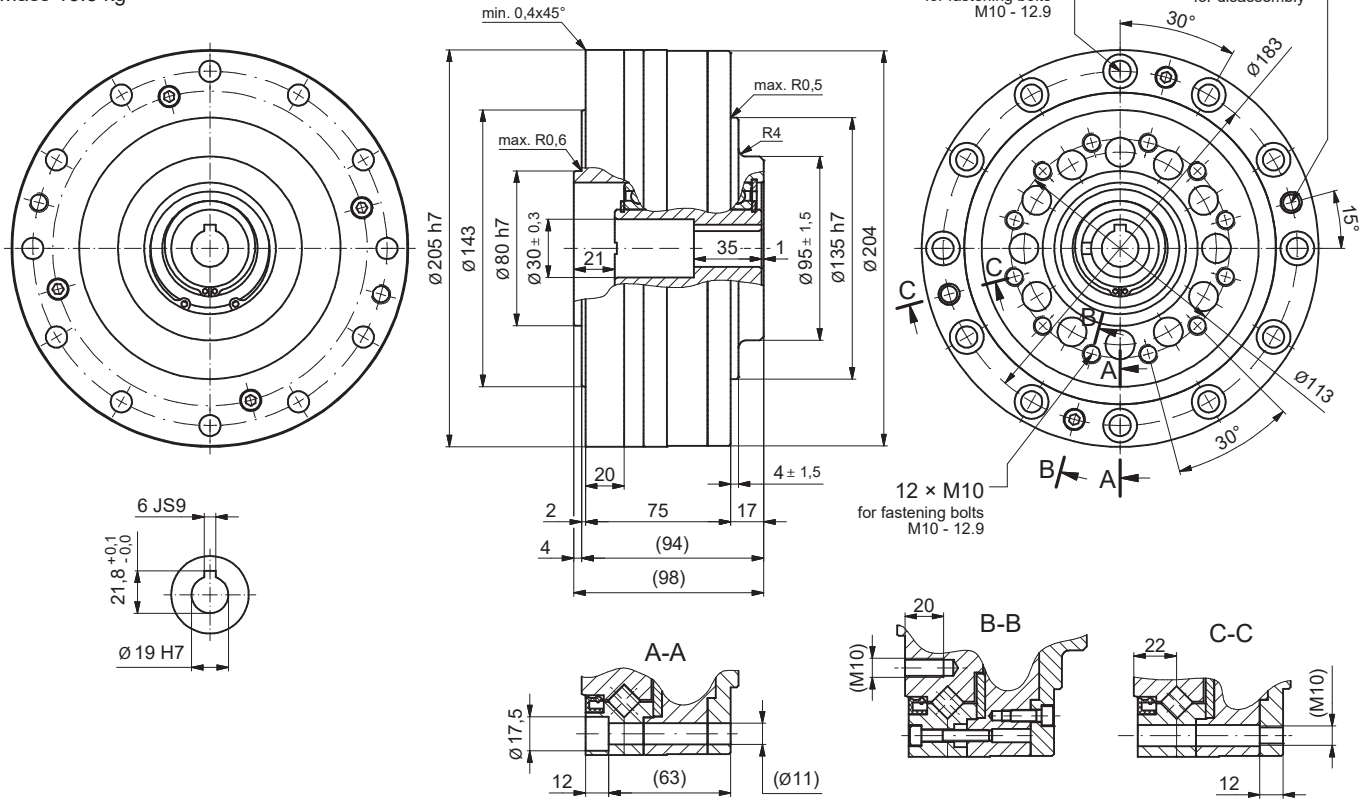

F1C-A45G

Mass 30 kg

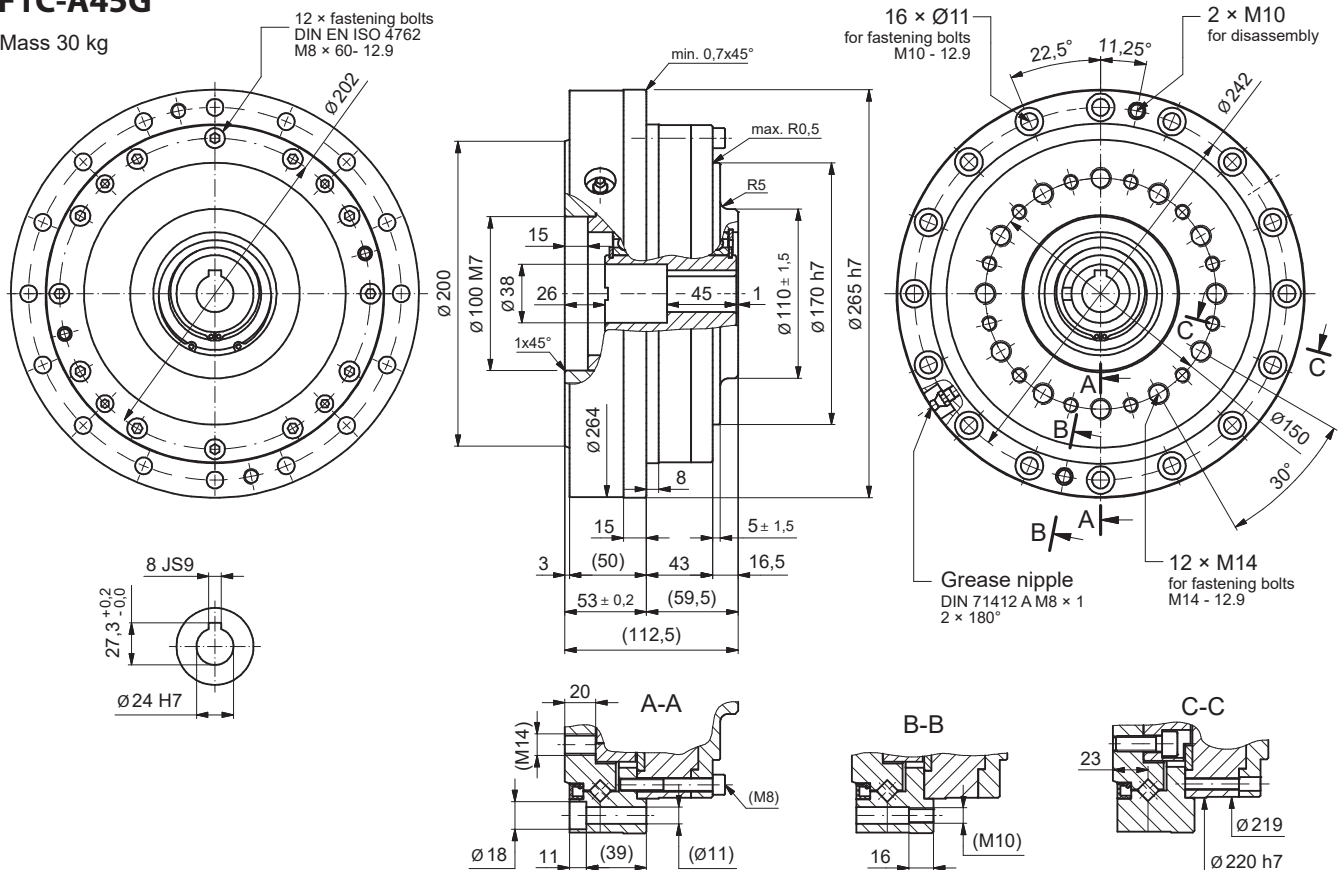

F1C-A65G

Mass 64 kg

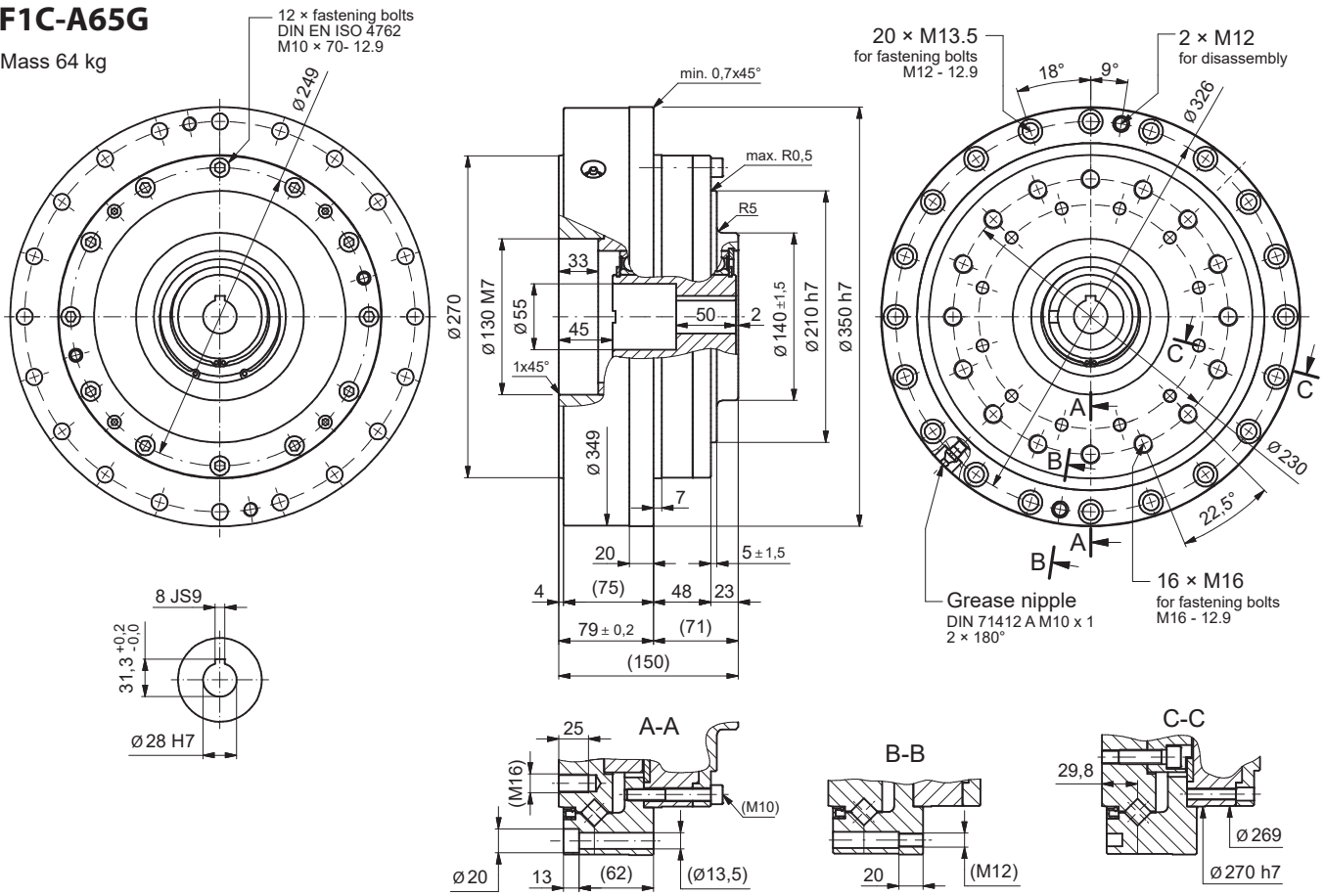

F1C-A75G

Mass 107 kg

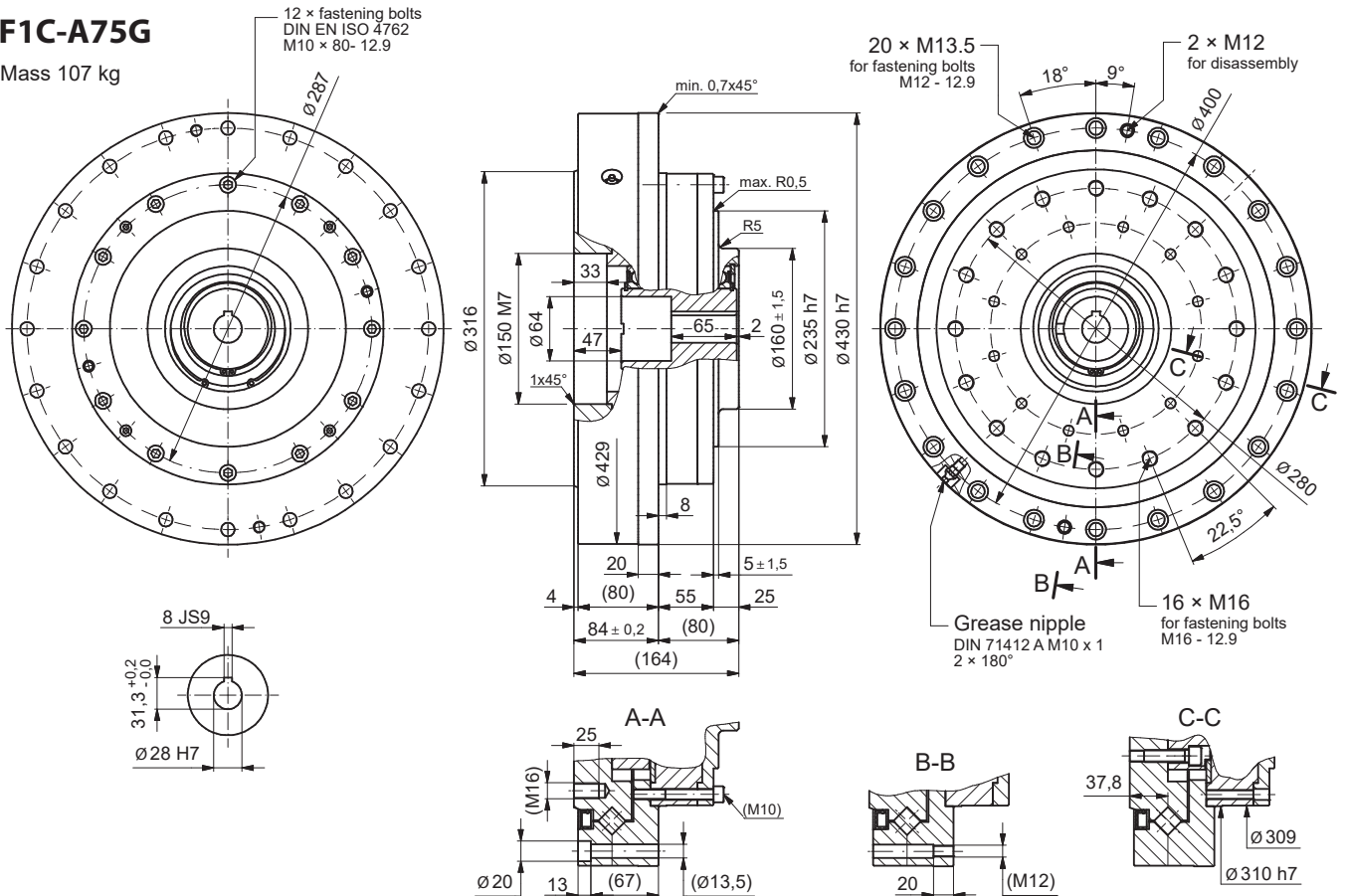

5.11 Model F2C(F)-A

5.11.1 Assembly tolerances

To ensure the function, lifetime, and characteristics of the gearbox, the radial run-out of the shaft ends, the coaxiality and the axial run-out of the fastening surface as per EN 50347:2001 are sufficient. When used in high-precision applications, the tolerance according to EN 50347:2001 should be reduced by 50%, which has additional advantages.

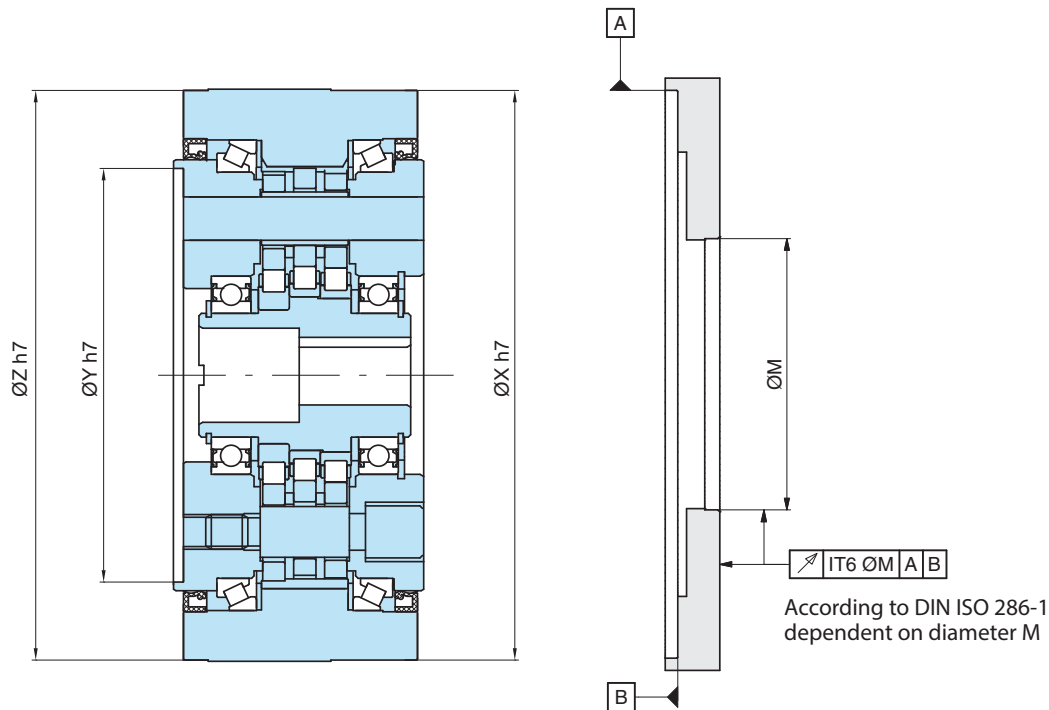

F2C-				
Size	Ø X	Ø Y	Ø Z	Ø M
A15	125	84	125	 Motor centering
A25	155	106	155	
A35	185	133	185	
A45	230	167	230	

Table A-32 (Dimensions in mm)

F2CF-				
Size	Ø X	Ø Y	Ø Z	Ø M
A15	123	84	124	 Motor centering
A25	160	106	160	
A35	190	133	190	
A45	220	167	220	

Table A-33 (Dimensions in mm)

5.11.2 Tightening torque and maximum permissible transmittable torque for bolts

The permissible transmitted torque for bolts and the number, size, and tightening torque for fastening the output side flange and the ring gear housing are listed in Table A-34. In the event of an Emergency Stop with corresponding load peaks, the output flange and ring gear housing bolts must all be replaced.

Size F2C(F)-	Output flange bolts		Bolts for ring gear (housing)		Max. permissible transmittable torque for bolts [Nm]
	Number and size of bolts	Tightening torque [Nm]	Number and size of bolts	Tightening torque [Nm]	
A15	12 × M6	16	16 × M6 (8 × M6)*	16	700
A25	12 × M8	39	12 × M8 (16 × M8)*	39	1500
A35	12 × M10	77	16 × M8	39	3200
A45	12 × M14	210	12 × M12 (16 × M10)*	135 (77)*	8200

Table A-34

* Values in brackets apply only for type F2CF-A

- **Bolting:** Use metric hexagon socket head screws (DIN 4762, strength category 12.9).
- **Countermeasure for bolts loosening:** Use adhesives (Loctite 262, etc.) or spring washer (DIN 127A).
- **Use spring washers** (DIN 6796) when connecting the gearbox to the flange side, so that the bolt contact faces do not get damaged.

5.11.3 Installation example

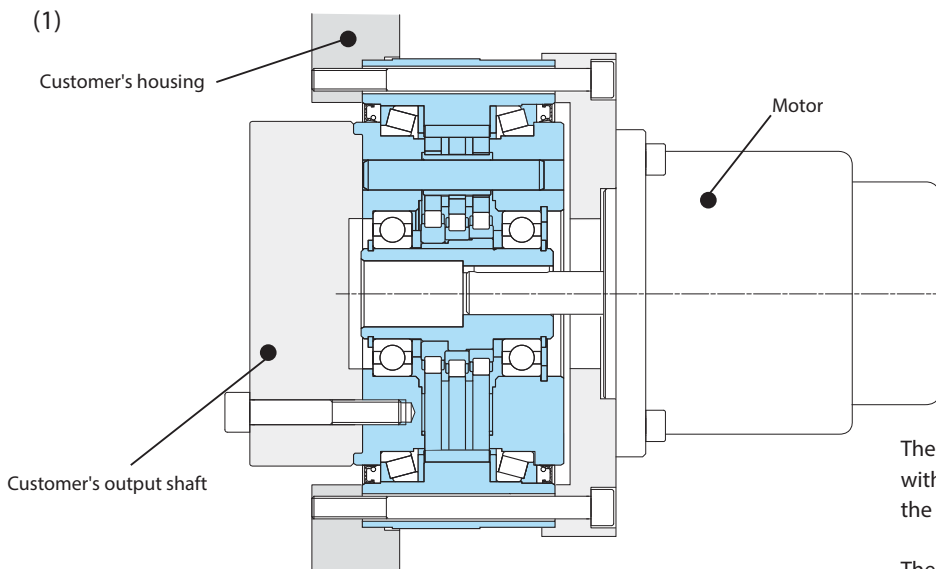

The motor is connected via an intermediate flange with the Fine Cyclo F2C-A gearbox and bolted onto the customer's housing.

The customer's output shaft is bolted to the output flange of the gearbox.

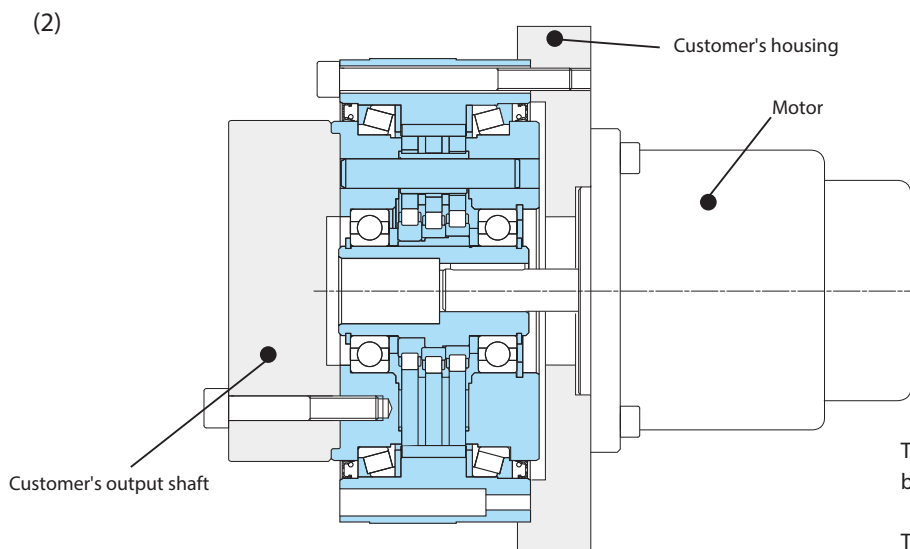

The motor and the Fine Cyclo F2C-A gearbox are both bolted onto the customer's housing.

The customer's output shaft is bolted to the output flange of the gearbox.

Sold & Serviced By:



Toll Free Phone (877) SERV098

www.electromate.com

sales@electromate.com

5.11.4 Dimensioned drawings

F2C-A15

Mass 5.0 kg

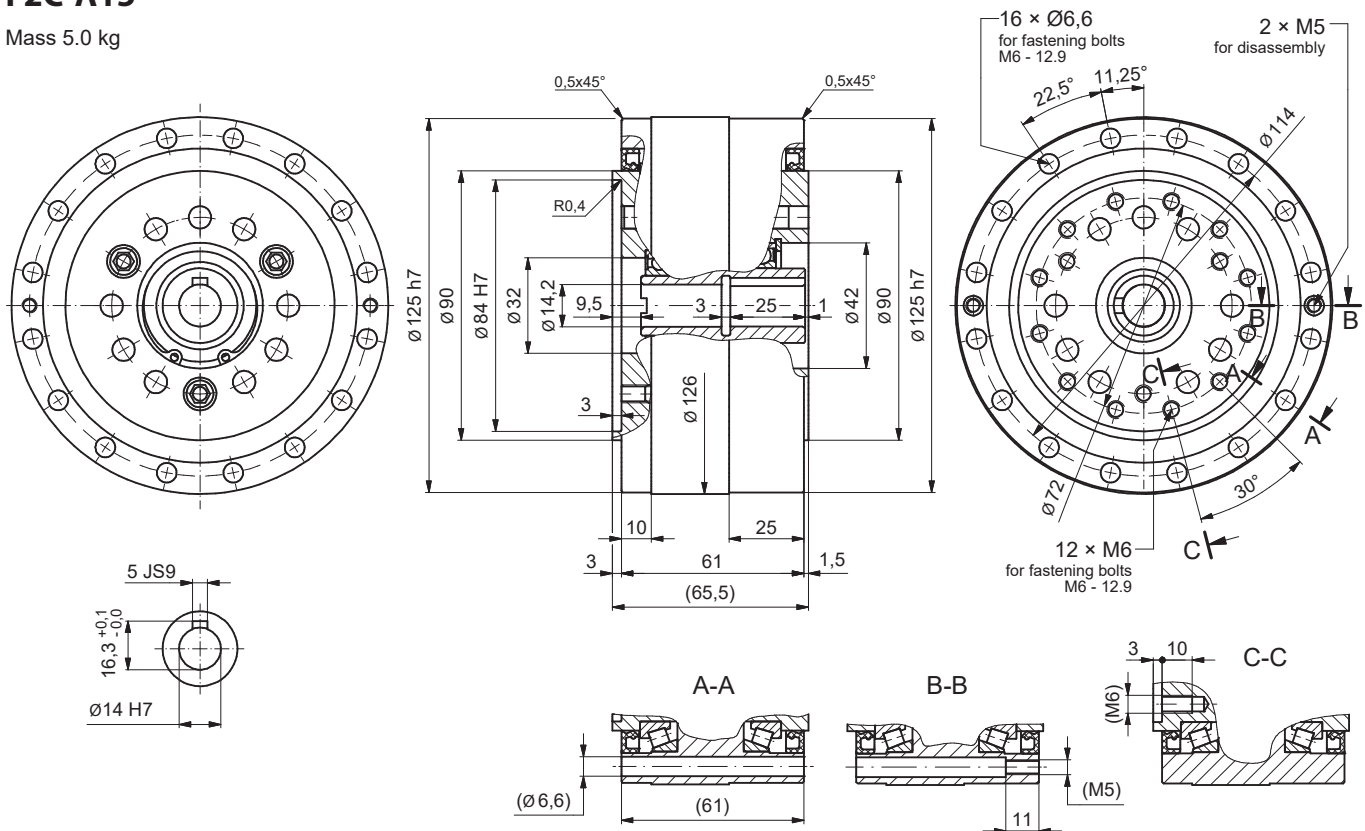

F2CF-A15

Mass 5.5 kg

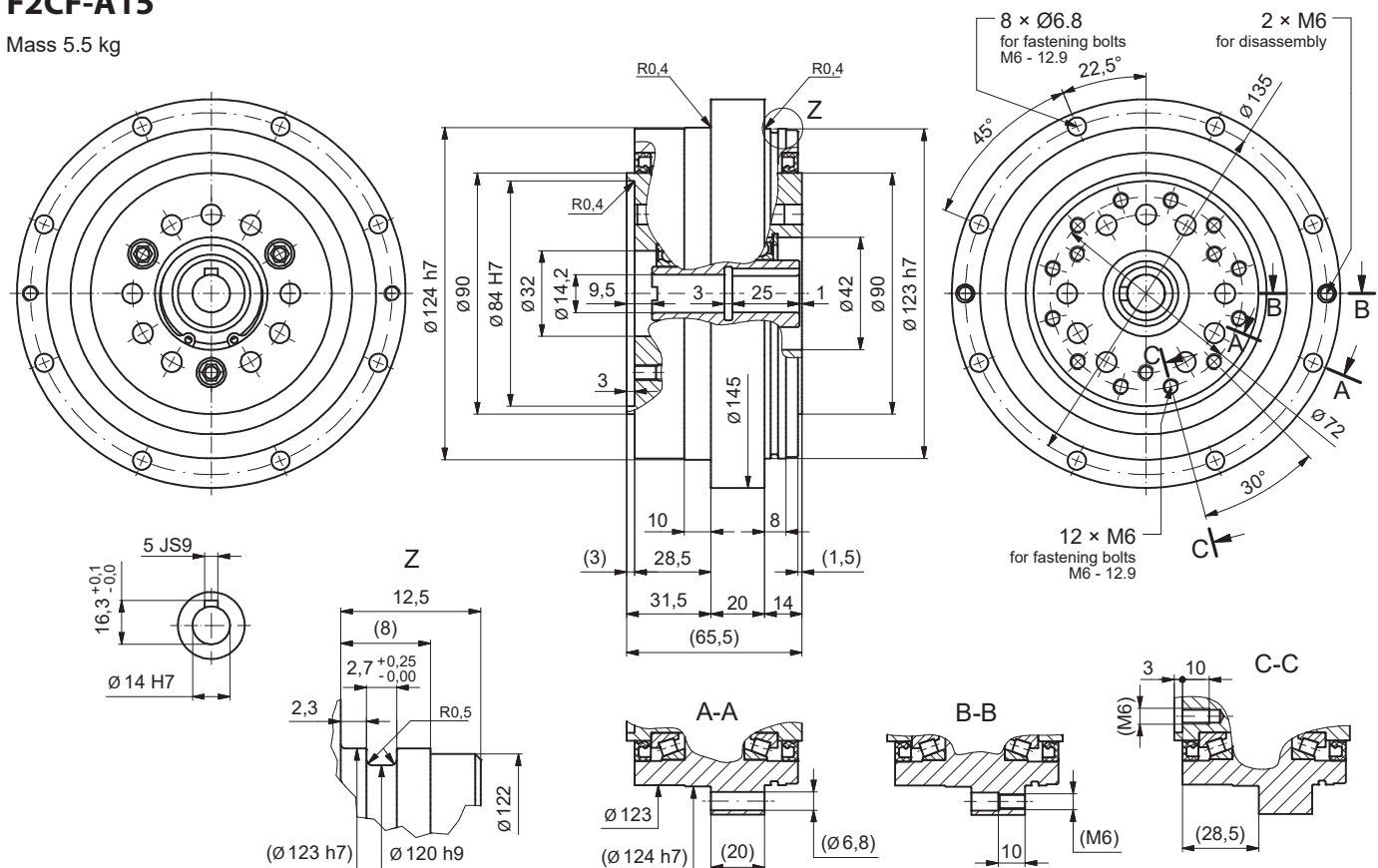

F2C-A25

Mass 7.3 kg

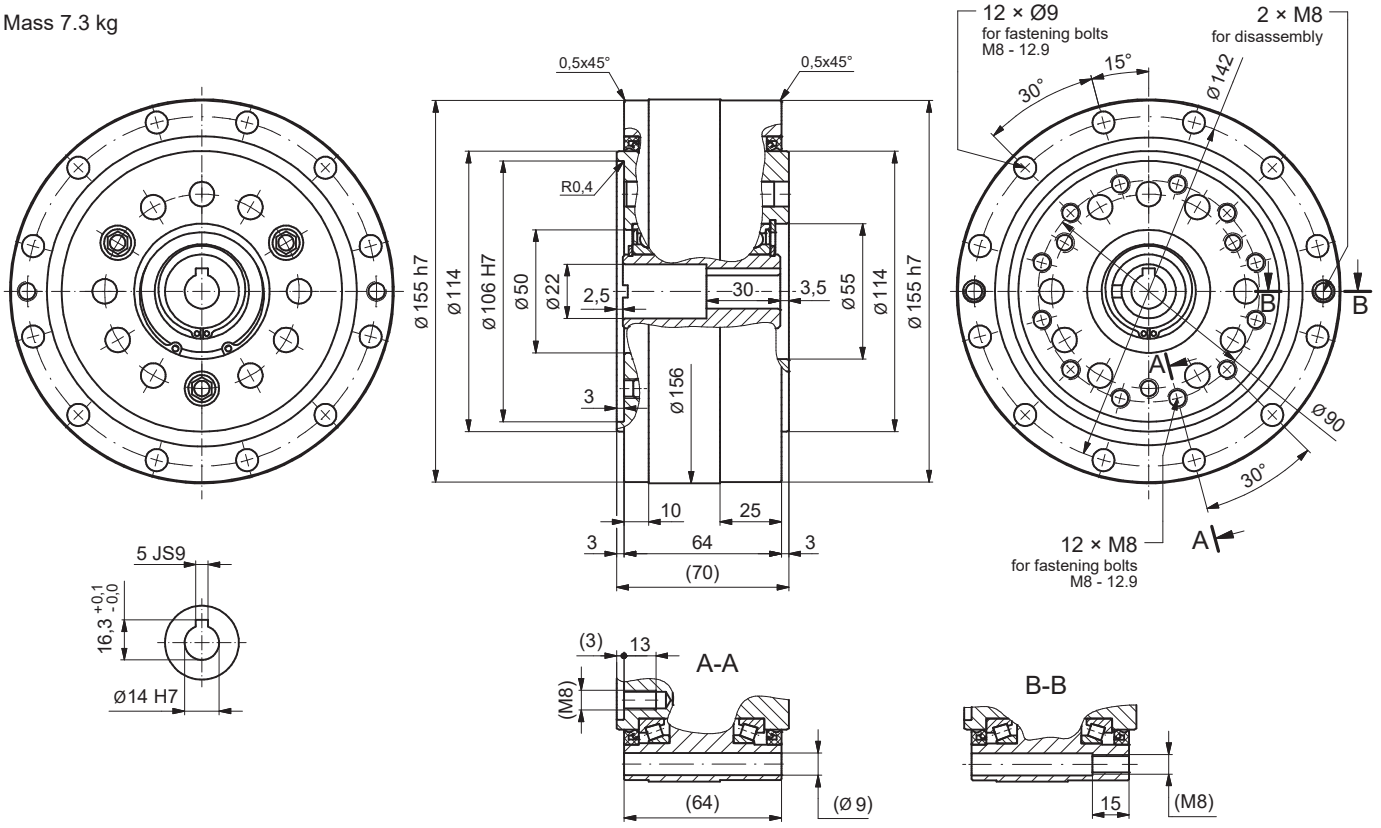

F2CF-A25

Mass 9.2 kg

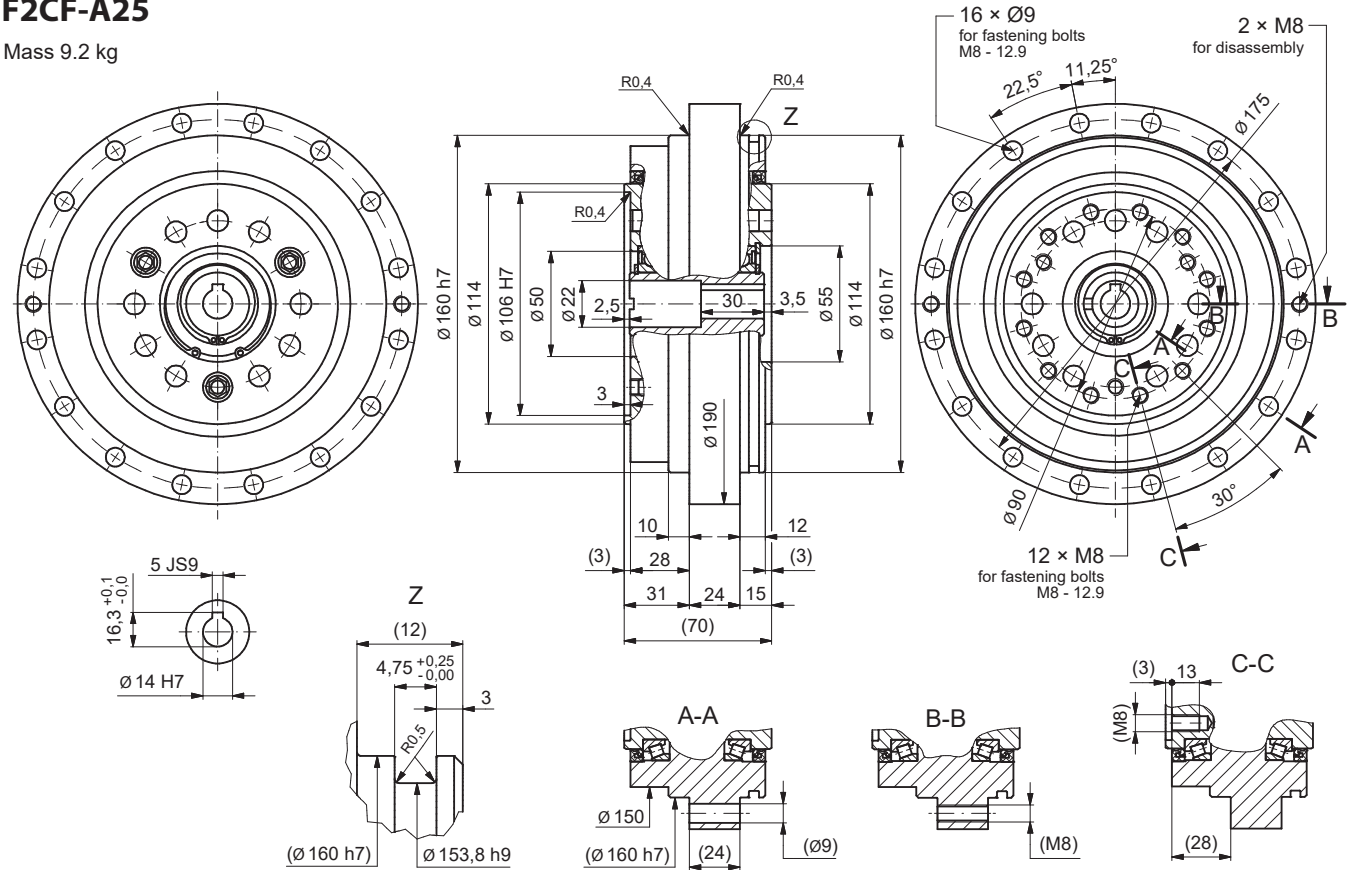

F2C-A35

Mass 13.0 kg

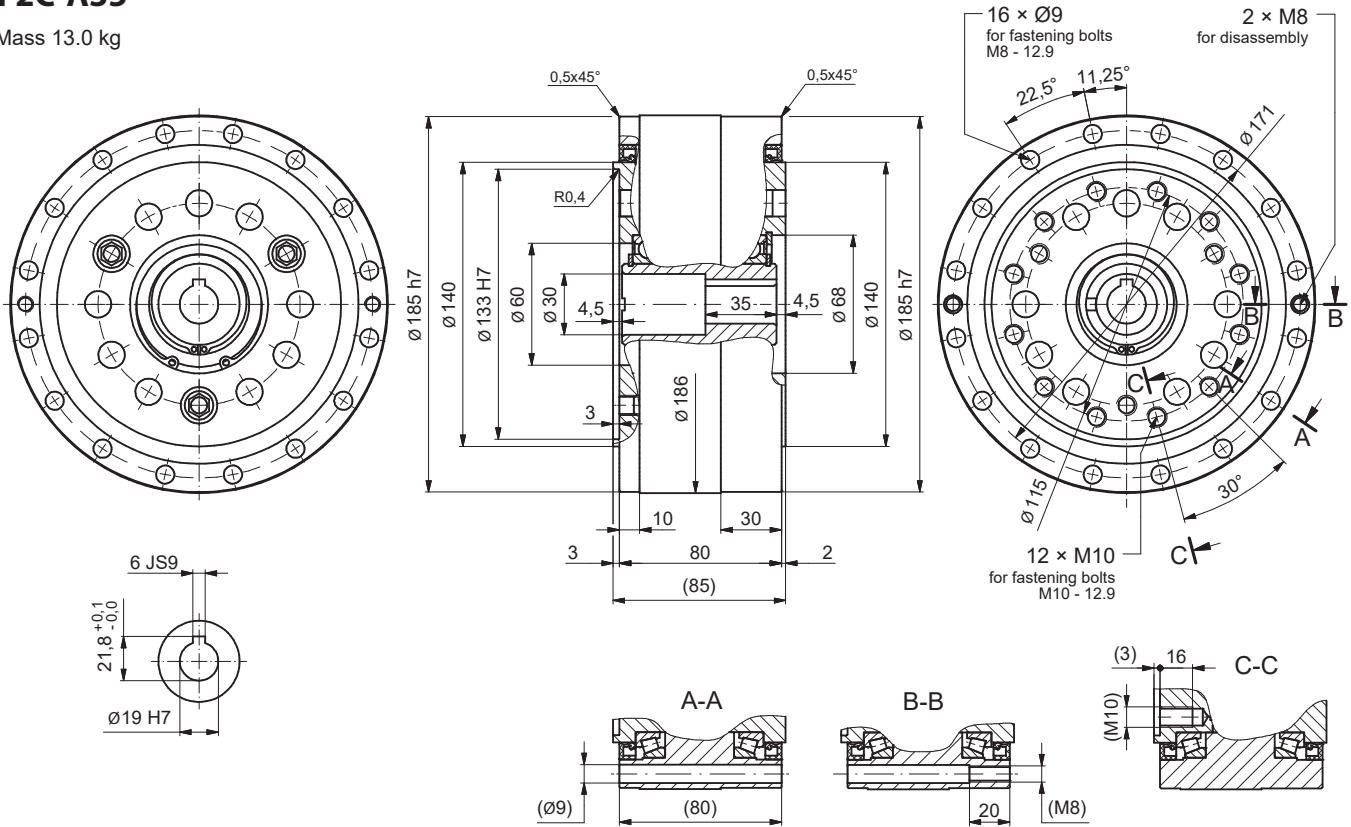

F2CF-A35

Mass 13.6 kg

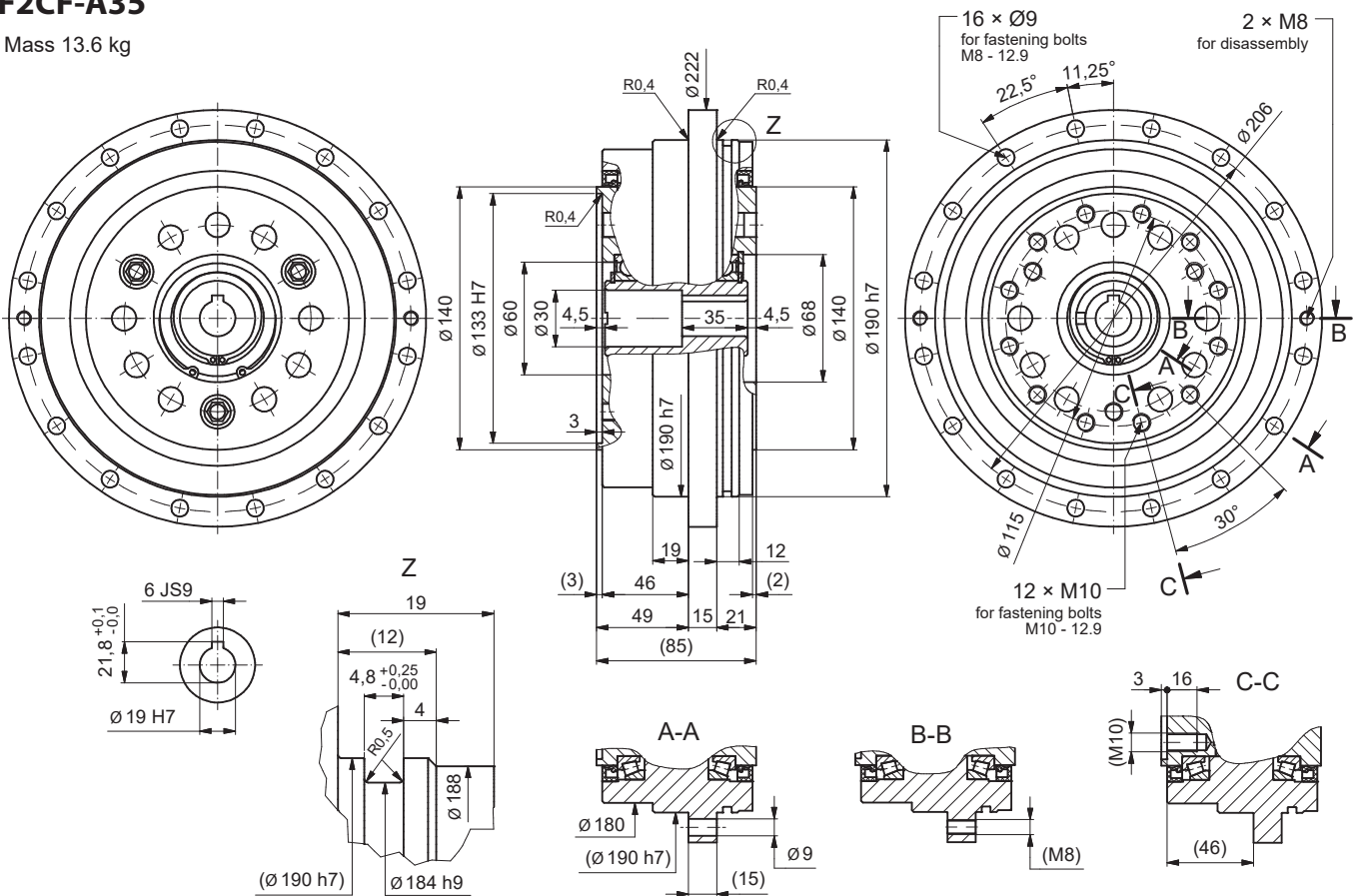

5.12 Model F3C-A

5.12.1 Assembly tolerances

To ensure the function, lifetime, and characteristics of the gearbox, the radial run-out of the shaft ends, the coaxiality and the axial run-out of the fastening surface as per EN 50347:2001 are sufficient. When used in high-precision applications, the tolerance according to EN 50347:2001 should be reduced by 50%, which has additional advantages.

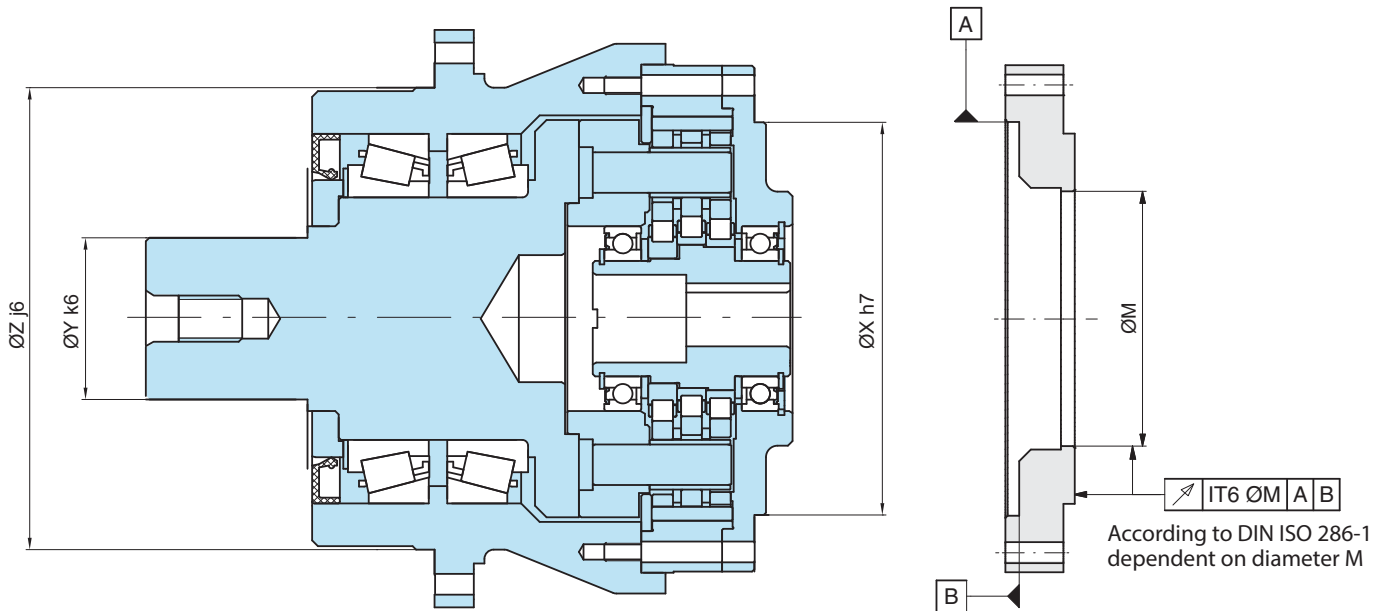

Size	Ø X	Ø Y	Ø Z	Ø M
A15	85	35	110	 Motor centering
A25	110	45	135	
A35	135	55	160	
A45	170	70	200	
A65	210	90	240	
A75	235	100	280	

Table A-35 (Dimensions in mm)

Sold & Serviced By:



Toll Free Phone (877) SERV098
www.electromate.com
sales@electromate.com

Tightening torque and maximum permissible transmittable torque for bolts

The permissible transmitted torque for bolts and the number, size, and tightening torque for fastening the output side flange and the ring gear housing are listed in Table A-36. In the event of an Emergency Stop with corresponding load peaks, the output flange and ring gear housing bolts must all be replaced.

Size F3C-	Bolts for ring gear (housing)		
	Number and size of bolts	Tightening torque [Nm]	Max. permissible transmittable torque for bolts [Nm]
A15G	8 × M6	16	550
A25G	8 × M6	16	1000
A35G	8 × M8	39	2100
A45G	12 × M8	39	4000
A65G	12 × M10	77	7700
A75G	12 × M10	77	9000

Table A-36

- **Bolting:** Use metric hexagon socket head screws (DIN 4762, strength category 12.9).
- **Countermeasure for bolts loosening:** We recommend using a threadlocker such as Loctite 243 to secure the screw connection.

5.12.2 Installation example

(1)

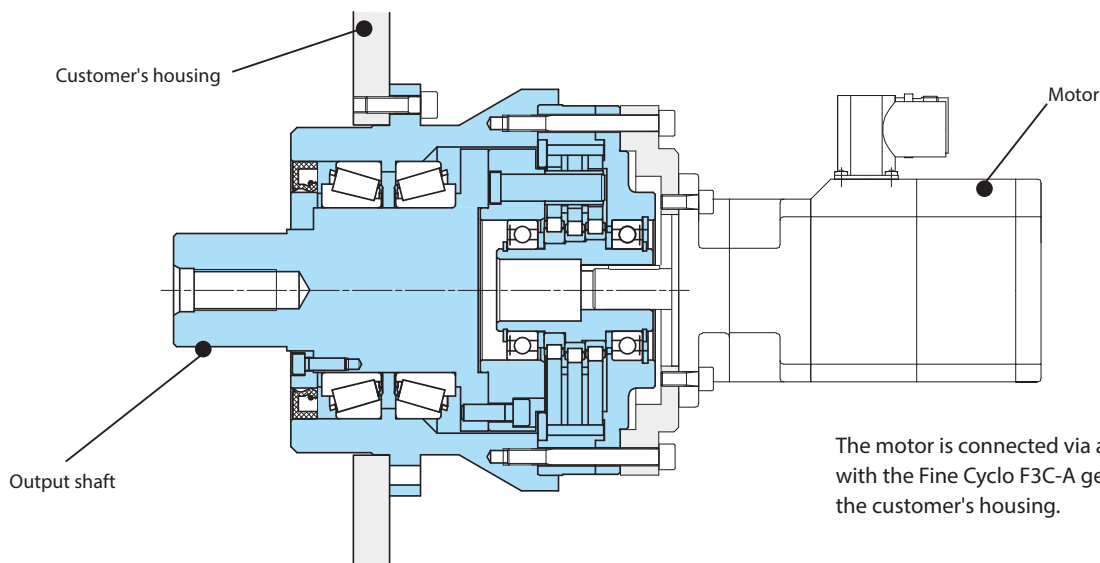

The motor is connected via an intermediate flange with the Fine Cyclo F3C-A gearbox and bolted onto the customer's housing.

Sold & Serviced By:

 **ELECTROMATE**

Toll Free Phone (877) SERV098

www.electromate.com

sales@electromate.com

5.12.3 Dimensioned drawings

F3C-A15G

Mass 8.5 kg

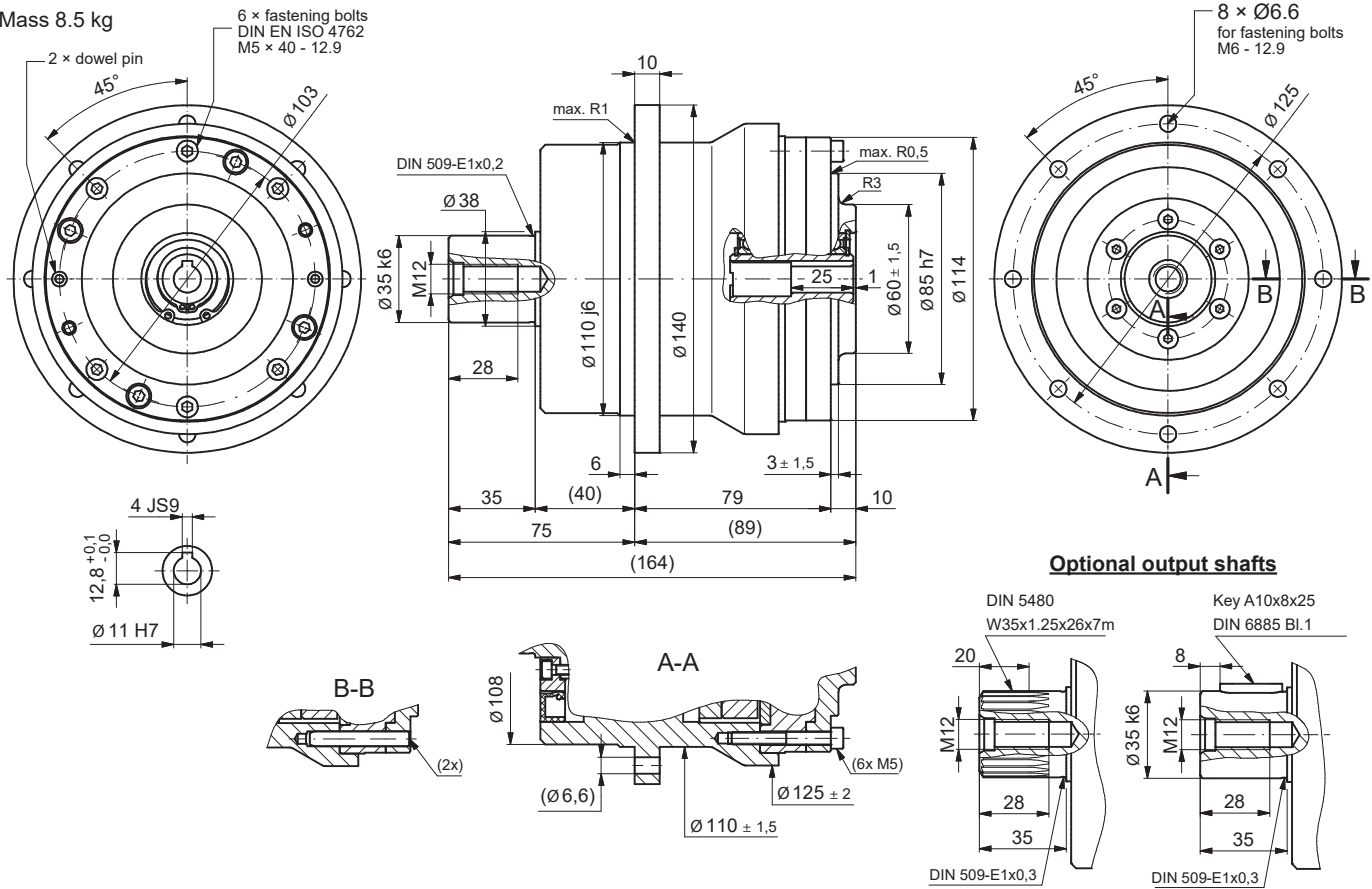

Optional output shafts

F3C-A25G

Mass 15.5 kg

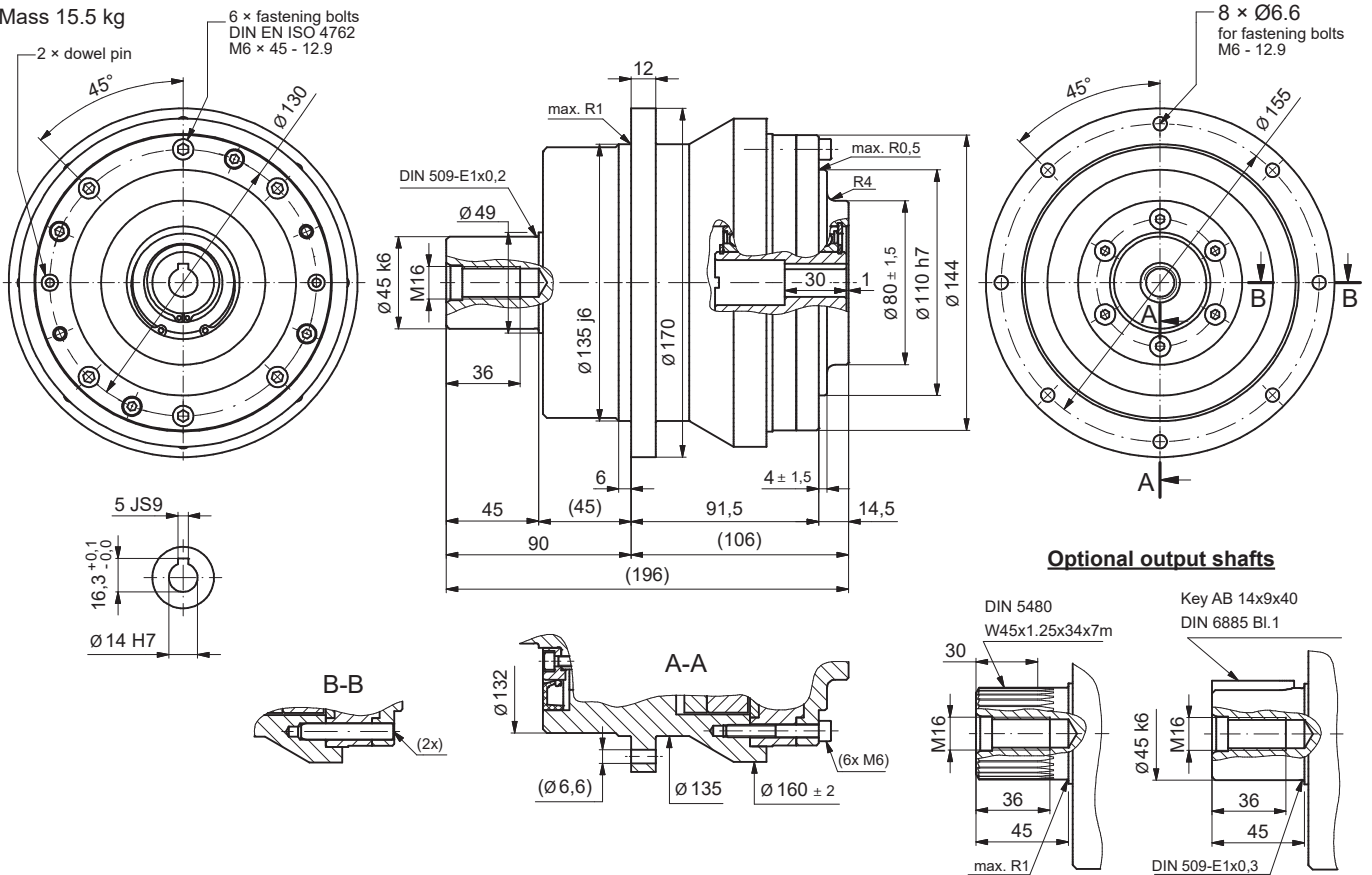

Optional output shafts

F3C-A35G

Mass 27 kg

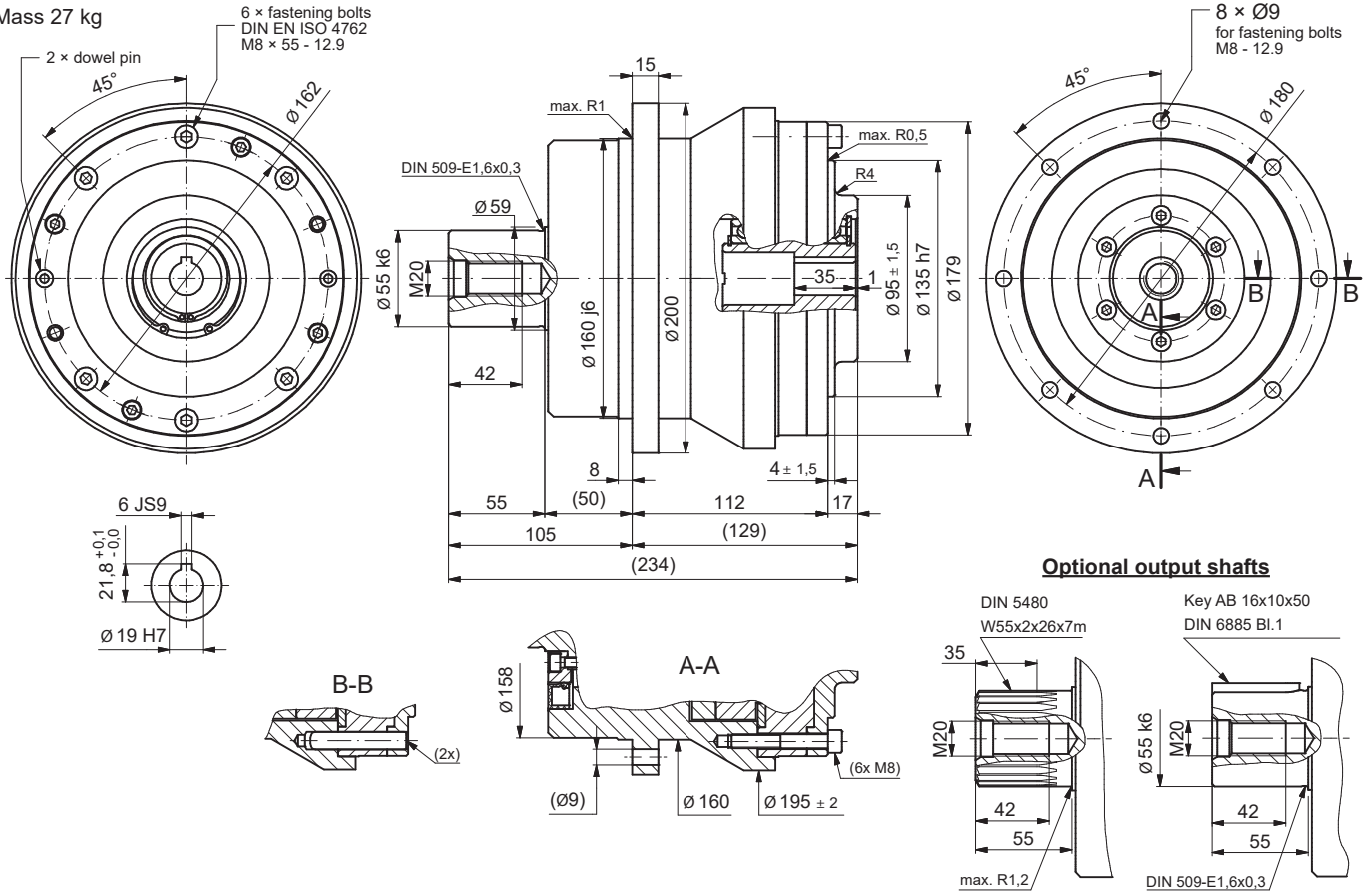

F3C-A45G

Mass 48 kg

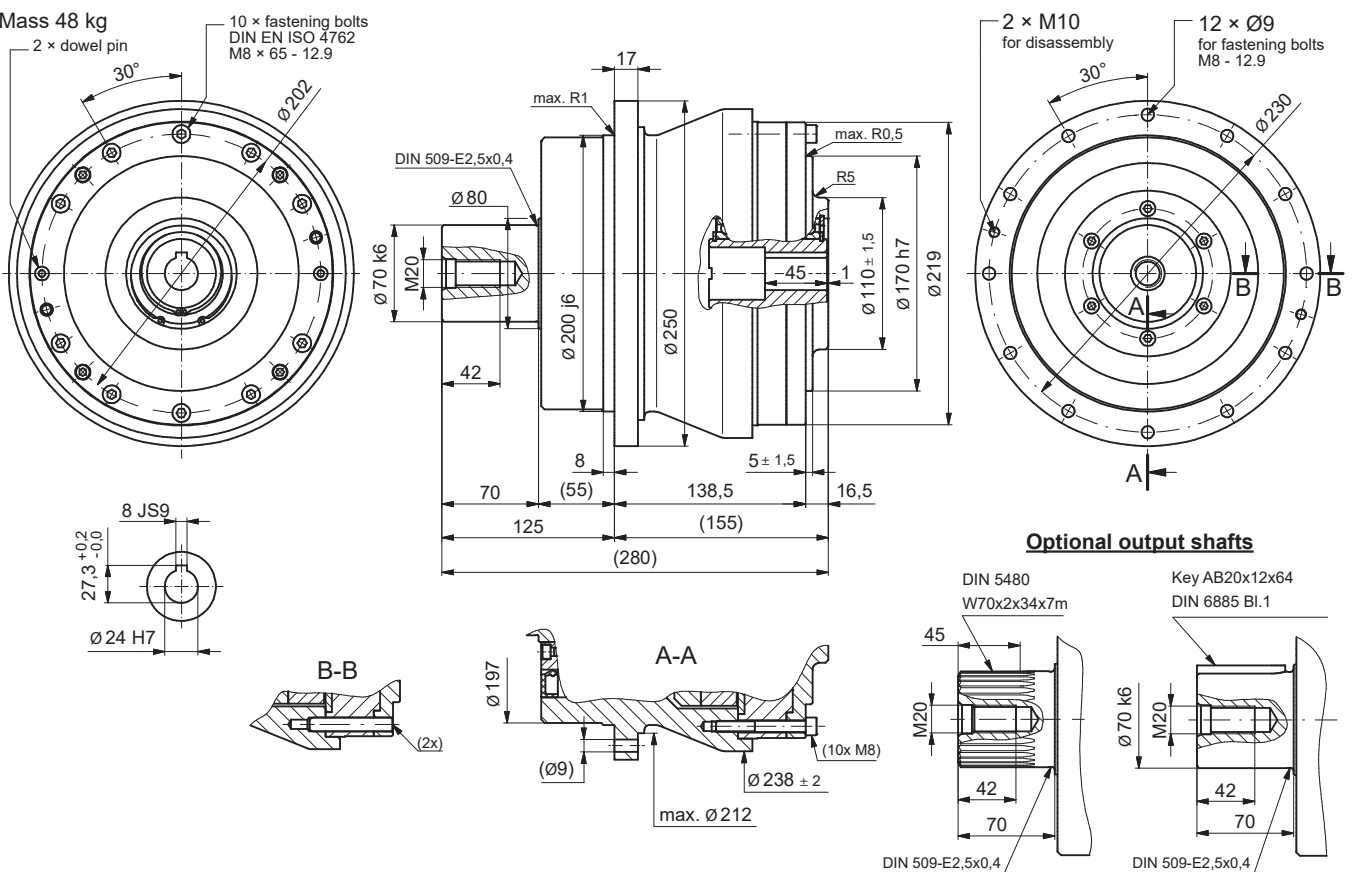

F3C-A65G

Mass 94 kg

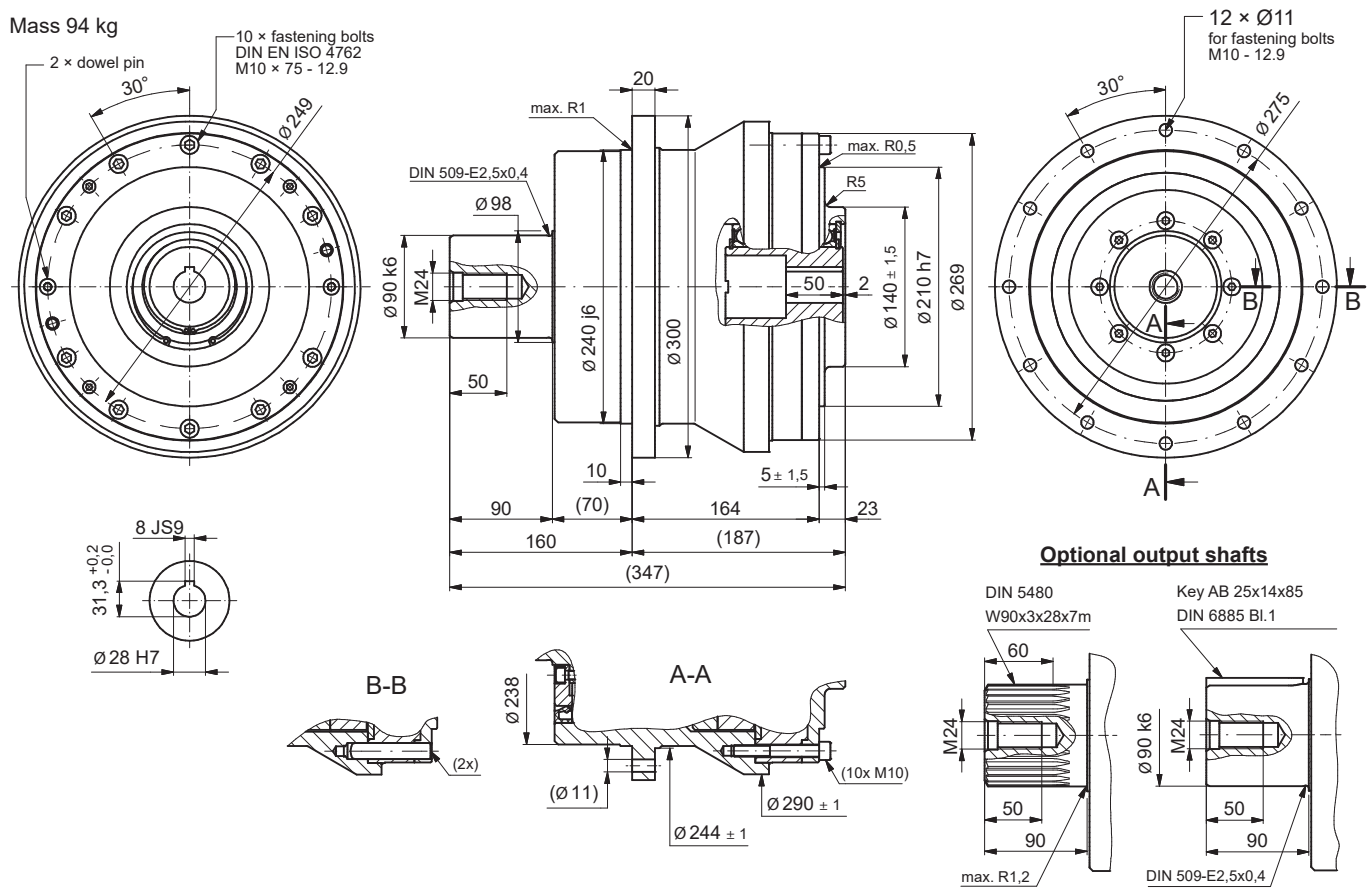

F3C-A75G

Mass 134 kg

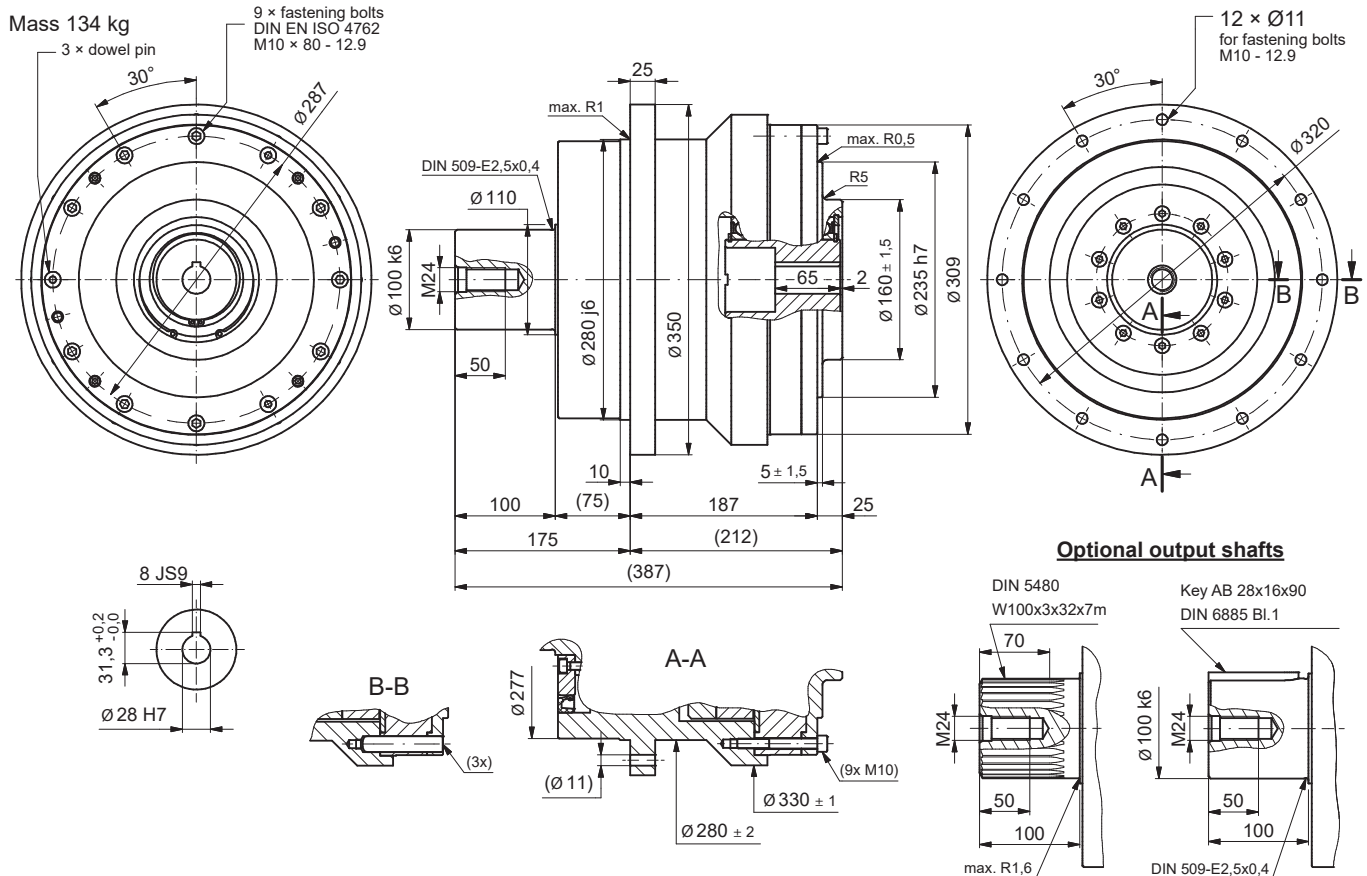

6 DA-Series

F4CF-DA

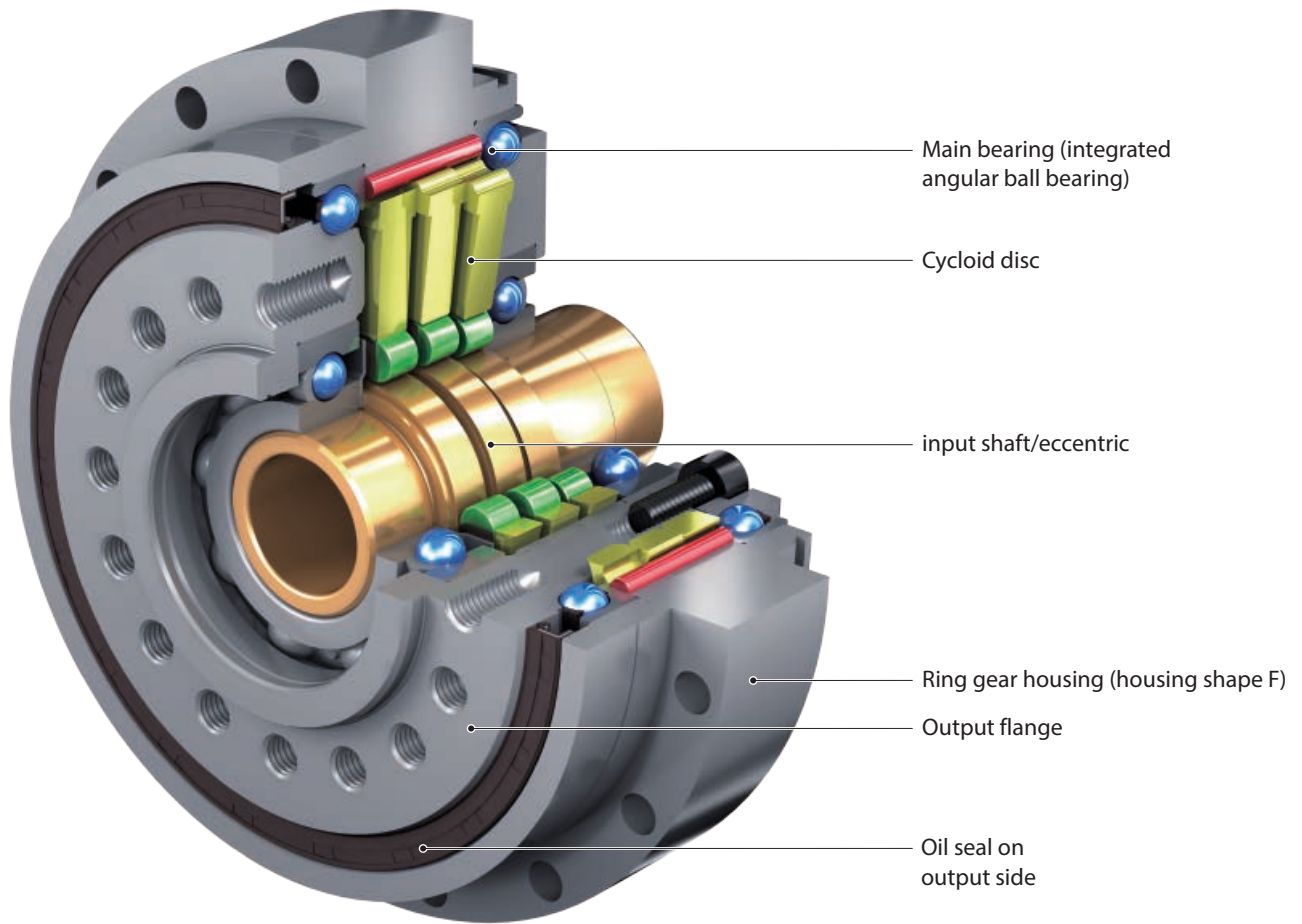

Special feature:

- Last Motion < 1 arcmin
- 6 sizes
- High acceleration torque up to 4,000 Nm
- Torsional stiffness up to 540 Nm/arcmin
- Low-noise design

Sold & Serviced By:



Toll Free Phone (877) SERV098
www.electromate.com
sales@electromate.com

6.1 Torques according to output speeds

Output speed n_{2m} [min ⁻¹]		5			10			15			20			25			
Model	Size	Reduction ratio i	Nominal output torque	Input speed	Max. permissible input power	Nominal output torque	Input speed	Max. permissible input power	Nominal output torque	Input speed	Max. permissible input power	Nominal output torque	Input speed	Max. permissible input power	Nominal output torque	Input speed	Max. permissible input power
			[Nm]	[min ⁻¹]	[kW]	[Nm]	[min ⁻¹]	[kW]	[Nm]	[min ⁻¹]	[kW]	[Nm]	[min ⁻¹]	[kW]	[Nm]	[min ⁻¹]	[kW]
F4CF	DA15	41	338	205	0.22	338	410	0.44	336	615	0.66	308	820	0.81	288	1025	0.94
		59	338	295	0.22	338	590	0.44	301	885	0.59	276	1180	0.72	258	1475	0.84
		89	338	445	0.22	300	890	0.39	266	1335	0.52	244	1780	0.64	228	2225	0.75
		119	340	595	0.22	277	1190	0.36	245	1785	0.48	225	2380	0.59	210	2975	0.69
	DA25	29	625	145	0.41	625	290	0.82	625	435	1.23	573	580	1.50	536	725	1.75
		41	567	205	0.37	567	410	0.74	563	615	1.11	517	820	1.35	483	1025	1.58
		59	567	295	0.37	567	590	0.74	505	885	0.99	463	1180	1.21	433	1475	1.42
		89	567	445	0.37	504	890	0.66	446	1335	0.88	410	1780	1.07	383	2225	1.25
	DA35	119	571	595	0.37	465	1190	0.61	412	1785	0.81	378	2380	0.99	353	2975	1.16
		29	846	145	0.55	846	290	1.11	846	435	1.66	776	580	2.03	726	725	2.38
		41	1081	205	0.71	1081	410	1.41	1073	615	2.11	984	820	2.58	920	1025	3.01
		59	1081	295	0.71	1081	590	1.41	962	885	1.89	882	1180	2.31	825	1475	2.70
	DA40	89	1081	445	0.71	960	890	1.26	850	1335	1.67	780	1780	2.04	730	2225	2.39
		119	1087	595	0.71	885	1190	1.16	784	1785	1.54	719	2380	1.88	673	2975	2.20
		41	1379	205	0.90	1379	410	1.80	1369	615	2.69	1255	820	3.29	1174	1025	3.84
		59	1379	295	0.90	1379	590	1.80	1227	885	2.41	1126	1180	2.95	1053	1475	3.44
	DA45	89	1379	445	0.90	1225	890	1.60	1085	1335	2.13	995	1780	2.60	930	2225	3.04
		119	1387	595	0.91	1129	1190	1.48	1000	1785	1.96	917	2380	2.40			
		29	1674	145	1.10	1674	290	2.19	1674	435	3.29	1535	580	4.02	1436	725	4.70
		41	1689	205	1.11	1689	410	2.21	1676	615	3.29	1538	820	4.03	1438	1025	4.71
	A50	59	1689	295	1.11	1689	590	2.21	1503	885	2.95	1379	1180	3.61	1289	1475	4.22
		89	1689	445	1.11	1500	890	1.96	1328	1335	2.61	1219	1780	3.19	1140	2225	3.73
		119	1699	595	1.11	1383	1190	1.81	1225	1785	2.41	1124	2380	2.94			
		41	2206	205	1.44	2206	410	2.89	2190	615	4.30	2009	820	5.26	1879	1025	6.15
	A50	59	2206	295	1.44	2206	590	2.89	1963	885	3.85	1801	1180	4.71	1684	1475	5.51
		89	2206	445	1.44	1960	890	2.57	1735	1335	3.41	1592	1780	4.17	1489	2225	4.87
		119	2219	595	1.45	1807	1190	2.37	1600	1785	3.14	1468	2380	3.84			

Table DA-1 Rating values (reference value output speed n_{2m})

Size	Reduction ratio i	Max. acceleration and deceleration torque T_{2A}	Peak torque for emergency stop T_{2max}^*
		[Nm]	[Nm]
DA15	41-119	613	1225
DA25	29-119	1029	2058
DA35	29	1393	2786
	41-119	1960	3920
DA40	41-119	2500	5000
DA45	29	2756	5513
	41-119	3062	6125
DA50	41-119	4000	8000

Table DA-2 Maximum acceleration and peak torque

* Further limitation by maximum transmittable torque of screw fitting Table DA-21, Page 76

30			40			50			60			Max. permissible input speed $n_{1,max}$ short term [min ⁻¹]	Max. permissible input speed $n_{1,ED}$ [min ⁻¹]		Max. moment of inertia J related to the input shaft of the basic gearbox [$\times 10^{-4}$ kgm ²]	Mass [kg]
Nominal output torque [Nm]	Input speed [min ⁻¹]	Max. permissible input power [kW]	Nominal output torque [Nm]	Input speed [min ⁻¹]	Max. permissible input power [kW]	Nominal output torque [Nm]	Input speed [min ⁻¹]	Max. permissible input power [kW]	Nominal output torque [Nm]	Input speed [min ⁻¹]	Max. permissible input power [kW]		50% ED	100% ED		
273	1230	1.07	250	1640	1.31	234	2050	1.53	221	2460	1.74	6150	5600	2800	0.90	4.7
244	1770	0.96	224	2360	1.17	210	2950	1.37	198	3540	1.56					
216	2670	0.85	198	3560	1.04	185	4450	1.21	175	5340	1.38					
199	3570	0.78	183	4760	0.96							5050	3700	1850	2.80	7.6
508	870	1.99	466	1160	2.44	435	1450	2.85	412	1740	3.24					
458	1230	1.80	420	1640	2.20	393	2050	2.57	372	2460	2.92					
410	1770	1.61	376	2360	1.97	352	2950	2.30	333	3540	2.62	4550	2960	1480	6.73	11.8
363	2670	1.42	333	3560	1.74											
335	3570	1.31														
687	870	2.70	630	1160	3.30	590	1450	3.86	558	1740	4.38	3950	2900	1450	8.93	13.9
871	1230	3.42	799	1640	4.19	748	2050	4.89	708	2460	5.56					
781	1770	3.07	717	2360	3.75	670	2950	4.39								
691	2670	2.71										3550	2240	1120	16.43	17.8
1112	1230	4.36	1020	1640	5.34	954	2050	6.24	903	2460	7.09					
997	1770	3.91	914	2360	4.79											
881	2670	3.46										3150	2600	1300	24.06	22.3
1359	870	5.34	1247	1160	6.53	1166	1450	7.63	1104	1740	8.67					
1361	1230	5.35	1249	1640	6.54	1168	2050	7.64	1106	2460	8.68					
1221	1770	4.79	1120	2360	5.86											
1779	1230	6.98	1631	1640	8.54	1526	2050	9.99								
1595	1770	6.26	1463	2360	7.66											

Light grey : 50% ED range

Dark grey : 100% ED range (but max. 10 min. without pause)

- T_{2N} = nominal output torque
Nominal output torque corresponds to the max. permissible average load torque at all output speeds.
The nominal output torque for speeds less than 5 min⁻¹ is equal to the value at 5 min⁻¹.
The value for the maximum permissible input power is calculated from the nominal output torque at 100%.
This value takes the efficiency of Fine Cyclo into consideration.
- $n_{1,max}$ = maximum permissible input speed
However, it must be $n_{1,m}$ (mean input speed) < $n_{1,ED}$.
- $n_{1,ED}$ = permissible input speed according to duty cycle
- T_{2A} = max. Acceleration and braking torque (for fatigue strength at $2 \cdot 10^7$ load cycles)
Permissible peak torque for normal start and stop procedures.
- $T_{2,max}$ = max. permissible torque for Emergency Stop situations or in the event of heavy shocks (limited by the mechanical strength) (permissible 1000 times during the entire lifetime).
- The rated torque T_{2N} is calculated using the following equation when the speed is not shown in the table above:

$$T_{2N} = T_{2N,600} \left(\frac{600}{n_{1m}} \right)^{0.3}$$

T_{2N} : Rated torque at output speed n_{1m}
 $T_{2N,600}$: Rated torque at output speed n_{1m} is 600 min⁻¹

6.2 Torques according to input speeds

Input speed n_{1m} [min ⁻¹]			4000			3000			2500			2000			1750		
Model	Size	Reduction ratio i	4000			3000			2500			2000			1750		
			Nominal output torque [Nm]	Output speed [min ⁻¹]	Max. permissible input power [kW]	Nominal output torque [Nm]	Output speed [min ⁻¹]	Max. permissible input power [kW]	Nominal output torque [Nm]	Output speed [min ⁻¹]	Max. permissible input power [kW]	Nominal output torque [Nm]	Output speed [min ⁻¹]	Max. permissible input power [kW]	Nominal output torque [Nm]	Output speed [min ⁻¹]	Max. permissible input power [kW]
F4CF-	DA15	41	191	97.6	2.44	209	73.2	2.00	220	61.0	1.76	236	48.8	1.50	245	42.7	1.37
		59	191	67.8	1.70	209	50.8	1.39	220	42.4	1.22	236	33.9	1.05	245	29.7	0.95
		89	191	44.9	1.13	209	33.7	0.92	220	28.1	0.81	236	22.5	0.69	245	19.7	0.63
		119	192	33.6	0.85	210	25.2	0.69	221	21.0	0.61	237	16.8	0.52	246	14.7	0.47
	DA25	29				350	103.4	4.74	370	86.2	4.17	395	69.0	3.57	412	60.3	3.25
		41	321	97.6	4.10	350	73.2	3.35	370	61.0	2.95	395	48.8	2.52	412	42.7	2.30
		59	321	67.8	2.85	350	50.8	2.33	370	42.4	2.05	395	33.9	1.75	412	29.7	1.60
		89	321	44.9	1.89	350	33.7	1.54	370	28.1	1.36	395	22.5	1.16	412	19.7	1.06
	DA35	119	323	33.6	1.42	353	25.2	1.16	372	21.0	1.02	398	16.8	0.88	414	14.7	0.80
		29							501	86.2	5.65	535	69.0	4.83	557	60.3	4.40
		41				667	73.2	6.39	704	61.0	5.62	753	48.8	4.81	784	42.7	4.38
		59				667	50.8	4.44	704	42.4	3.91	753	33.9	3.34	784	29.7	3.04
	DA40	89				667	33.7	2.94	704	28.1	2.59	753	22.5	2.22	784	19.7	2.02
		119				671	25.2	2.21	709	21.0	1.95	758	16.8	1.67	789	14.7	1.52
		41							899	61.0	7.17	961	48.8	6.13	1000	42.7	5.59
		59							899	42.4	4.98	961	33.9	4.26	1000	29.7	3.88
	DA45	89							899	28.1	3.30	961	22.5	2.83	1000	19.7	2.57
		119							904	21.0	2.49	966	16.8	2.13	1006	14.7	1.94
		29										1059	69.0	9.56	1102	60.3	8.71
		41							1101	61.0	8.78	1177	48.8	7.51	1225	42.7	6.84
	DA50	59							1101	42.4	6.10	1177	33.9	5.22	1225	29.7	4.76
		89							1101	28.1	4.05	1177	22.5	3.46	1225	19.7	3.15
		119							1107	21.0	3.04	1184	16.8	2.60	1232	14.7	2.37
		41										1537	48.8	9.81	1600	42.7	8.94
	DA50	59										1537	33.9	6.82	1600	29.7	6.21
		89										1537	22.5	4.52	1600	19.7	4.12
		119										1546	16.8	3.40	1610	14.7	3.10

Table DA-3 Rating values (reference value input speed n_{1m})

Size	Reduction ratio i	Max. acceleration and deceleration torque T_{2A}	Peak torque for emergency stop T_{2max}^*
		[Nm]	[Nm]
DA15	41-119	613	1225
DA25	29-119	1029	2058
DA35	29	1393	2786
	41-119	1960	3920
DA40	41-119	2500	5000
DA45	29	2756	5513
	41-119	3062	6125
DA50	41-119	4000	8000

Table DA-4 Maximum acceleration and peak torque

* Further limitation by maximum transmittable torque of screw fitting Table DA-21, Page 76

1500			1000			750			< 600			Max. permissible input speed $n_{1\max}$ short term [min ⁻¹]	Max. permissible input speed n_{1ED} [min ⁻¹]		Max. moment of inertia j related to the input shaft of the basic gearbox [×10 ⁻⁴ kgm ²]	Mass [kg]
Nominal output torque [Nm]	Output speed [min ⁻¹]	Max. permissible input power [kW]	Nominal output torque [Nm]	Output speed [min ⁻¹]	Max. permissible input power [kW]	Nominal output torque [Nm]	Output speed [min ⁻¹]	Max. permissible input power [kW]	Nominal output torque [Nm]	Output speed [min ⁻¹]	Max. permissible input power [kW]		50% ED	100% ED		
257	36.6	1.23	290	24.4	0.93	316	18.3	0.76	338	14.6	0.65	6150	5600	2800	0.90	4.7
257	25.4	0.85	290	16.9	0.64	316	12.7	0.53	338	10.2	0.45					
257	16.9	0.57	290	11.2	0.43	316	8.4	0.35	338	6.7	0.30					
258	12.6	0.43	292	8.4	0.32	318	6.3	0.26	340	5.0	0.22	5050	3700	1850	2.80	7.6
431	51.7	2.92	487	34.5	2.20	531	25.9	1.80	567	20.7	1.54					
431	36.6	2.06	487	24.4	1.55	531	18.3	1.27	567	14.6	1.09					
431	25.4	1.43	487	16.9	1.08	531	12.7	0.88	567	10.2	0.76	4550	4200	2100	6.73	11.8
431	16.9	0.95	487	11.2	0.72	531	8.4	0.59	567	6.7	0.50					
434	12.6	0.72	490	8.4	0.54	534	6.3	0.44	571	5.0	0.38					
584	51.7	3.95	659	34.5	2.97	718	25.9	2.43	768	20.7	2.08	3950	2900	1450	8.93	13.9
821	36.6	3.93	927	24.4	2.96	1011	18.3	2.42	1081	14.6	2.07					
821	25.4	2.73	927	16.9	2.06	1011	12.7	1.68	1081	10.2	1.44					
821	16.9	1.81	927	11.2	1.36	1011	8.4	1.12	1081	6.7	0.95	3550	2600	1300	16.43	17.8
826	12.6	1.36	933	8.4	1.03	1017	6.3	0.84	1087	5.0	0.72					
1047	36.6	5.02	1183	24.4	3.78	1289	18.3	3.09	1379	14.6	2.64					
1047	25.4	3.49	1183	16.9	2.62	1289	12.7	2.15	1379	10.2	1.84	3150	2400	1200	24.06	22.3
1047	16.9	2.31	1183	11.2	1.74	1289	8.4	1.42	1379	6.7	1.22					
1054	12.6	1.74	1190	8.4	1.31	1297	6.3	1.07	1387	5.0	0.92					
1154	51.7	7.82	1304	34.5	5.88	1421	25.9	4.81	1520	20.7	4.12	6150	5600	2800	0.90	4.7
1283	36.6	6.14	1449	24.4	4.62	1579	18.3	3.78	1689	14.6	3.23					
1283	25.4	4.27	1449	16.9	3.21	1579	12.7	2.63	1689	10.2	2.25					
1283	16.9	2.83	1449	11.2	2.13	1579	8.4	1.74	1689	6.7	1.49	5050	3700	1850	2.80	7.6
1291	12.6	2.13	1458	8.4	1.60	1589	6.3	1.31	1699	5.0	1.12					
1676	36.6	8.02	1892	24.4	6.04	2063	18.3	4.94	2206	14.6	4.23					
1676	25.4	5.58	1892	16.9	4.20	2063	12.7	3.43	2206	10.2	2.94	4550	4200	2100	6.73	11.8
1676	16.9	3.70	1892	11.2	2.78	2063	8.4	2.28	2206	6.7	1.95					
1686	12.6	2.78	1904	8.4	2.09	2075	6.3	1.71	2219	5.0	1.46					

Light grey : 50% ED range

Dark grey : 100% ED range (but max. 10 min. without pause)

- T_{2N} = nominal output torque
Nominal output torque corresponds to the max. permissible average load torque at all input speeds.
The nominal output torque for speeds less than 600 min⁻¹ is equal to the value at 600 min⁻¹.
The value for the maximum permissible input power is calculated from the nominal output torque at 100%.
This value takes the efficiency of Fine Cyclo into consideration.
- $n_{1\max}$ = maximum permissible input speed
However, it must be n_{1m} (mean input speed) < n_{1ED} .
- n_{1ED} = permissible input speed according to duty cycle
- T_{2A} = max. Acceleration and braking torque (for fatigue strength at 2 · 10⁷ load cycles)
Permissible peak torque for normal start and stop procedures.
- $T_{2\max}$ = max. permissible torque for Emergency Stop situations or in the event of heavy shocks (limited by the mechanical strength) (permissible 1000 times during the entire lifetime).
- The rated torque T_{2N} is calculated using the following equation when the speed is not shown in the table above:

$$T_{2N} = T_{2N,600} \left(\frac{600}{n_{1m}} \right)^{0.3}$$

T_{2N} : Rated torque at input speed n_{1m}
 $T_{2N,600}$: Rated torque at input speed n_{1m} is 600 min⁻¹

6.3 Stiffness and Lost Motion

Size	i	Test torque T_p [Nm]	Lost Motion	Torsional stiffness T_p [Nm/arcmin]
			Lost Motion [arcmin]	
DA15	41	10.1	1.0	49.0
	59	9.03		
	89	7.98		
	119	7.35		
DA25	29	18.8		73.0
	41	16.9		
	59	15.2		
	89	13.4		
DA35	119	12.4		112
	29	25.4		135
	41	32.2		
	59	28.9		
DA40	89	25.5		208
	119	23.5		
	41	41.1		186
	59	36.8		
DA45	89	32.6	286	
	119	30.0		
	29	50.2	224	
	41	50.3		
DA50	59	45.1	344	
	89	39.8		
	119	36.8	300	
	41	65.7		
DA50	59	58.9	540	
	89	52.1		
	119	48.0		

Table DA-5 Torsional stiffness

T_p : Test torque at input speed $n_1 = 1500 \text{ min}^{-1}$

Calculation of the twist angle:

1) At a load torque less than $3\% T_p$

$$\varphi = \frac{\text{Lost Motion}}{2} \cdot \frac{\text{Load torque}}{0.03 \cdot T_p}$$

Note arcmin means "angular minute".
Table values for stiffness are average values.

2) At a load torque greater than $3\% T_p$ (standard case)

$$\varphi = \frac{\text{Lost Motion}}{2} + \frac{\text{Load torque} - (0.03 \cdot T_p)}{\text{Torsional stiffness}}$$

6.4 No-load running torque NLRT

No-load running torque

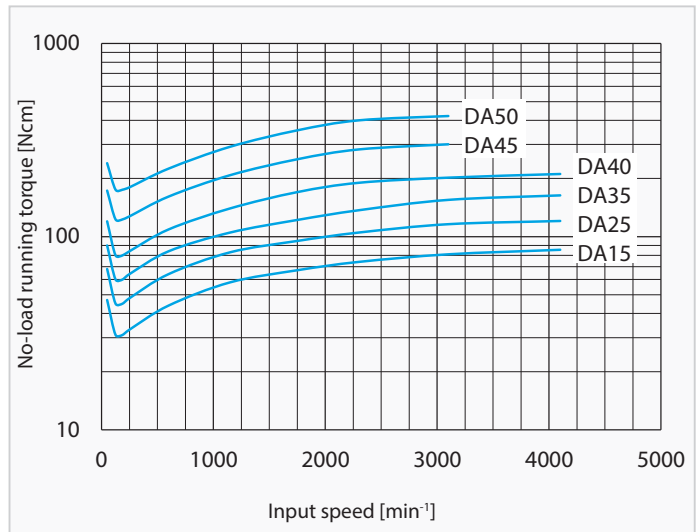

Fig. DA-1 Input side no-load running torque

Note

- Fig. DA-1 shows the average no-load running torque after gearbox is run in (not factory-new condition).
- Table DA-6 shows the measuring conditions.

6.5 Breakaway torque

Breakaway torque on output side (BTO)

- Note**
1. Table DA-7 shows the max. breakaway torque on the output side BTO. Fine Cyclo gearboxes are not self-locking. The BTO is defined as the maximum value (factory-new condition), which steadily decreases during the lifetime.
 2. Table DA-6 shows the measuring conditions.

Ring gear housing temperature	approx. 30 °C
Precision during assembly	as per chapter 6.8.1
Lubrication	Standard lubrication

Table DA-6 Measurement conditions

Size	Breakaway torque BTO [Nm]
DA15	< 34
DA25	< 60
DA35	< 72
DA40	< 88
DA45	< 125
DA50	< 167

Table DA-7 Value of the breakaway torque on the output side (BTO)

Breakaway torque on input side (BTI)

- Note**
1. Table DA-8 shows the max. breakaway torque BTI on the input side. BTI is defined as the maximum value (factory-new condition) which steadily decreases during the lifetime.
 2. Table DA-6 shows the measuring conditions.

Size	i	Breakaway torque BTI [Nm]
DA15	41	2.1
	59	1.4
	89	1.0
	119	0.7
DA25	29	5.2
	41	3.7
	59	2.5
	89	1.7
DA35	119	1.3
	29	6.2
	41	4.4
	59	3.1
DA40	89	2.0
	119	1.5
	41	5.4
	59	3.7
DA45	89	2.5
	119	1.8
	29	10.8
	41	7.6
DA50	59	5.3
	89	3.5
	119	2.6
	41	10.2
DA50	59	7.1
	89	4.7
	119	3.5
	41	10.2

Table DA-8 Value of the breakaway torque on the input side (BTI)

6.6 Efficiency

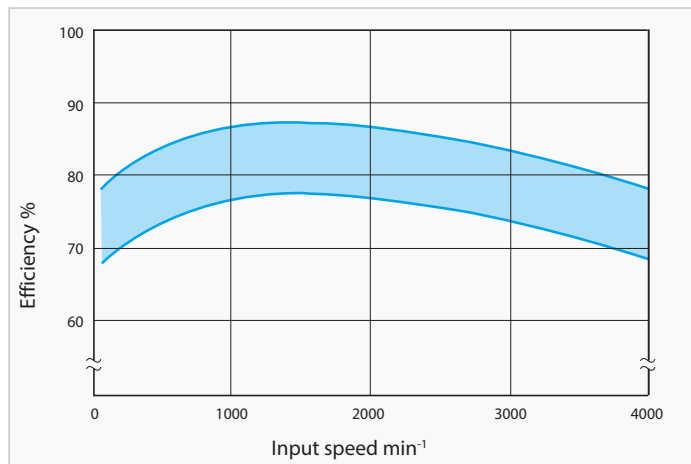

Fig. DA-2 Efficiency curve

Fig. DA-2 shows the correlation between efficiency and input speed. For further information, see "4 Description of technical specifications for cycloidal gearboxes" on page 22.

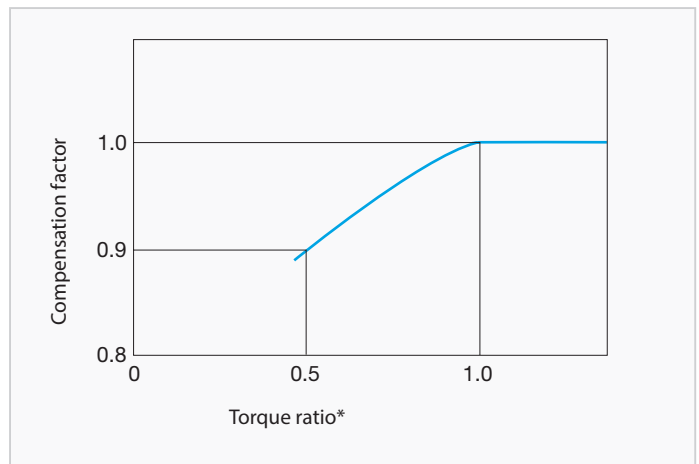

Fig. DA-3 Compensation curve for efficiency

$$* \text{ Torque ratio} = \frac{\text{Load torque}}{\text{Nominal output torque}}$$

$$\text{Compensation efficiency} = \text{efficiency} \cdot \text{compensation factor}$$

- Note**
1. The efficiency changes if the load torque does not match the nominal torque. Check the compensation factor in the diagram Fig. DA-3.
 2. When the torque ratio is over 1.0, the compensation factor for efficiency is 1.0 (diagram Fig. DA-3).

Sold & Serviced By:



Toll Free Phone (877) SERV098
www.electromate.com
sales@electromate.com

6.7 Bearing loads

6.7.1 Maximum permissible radial and axial load on the input shaft

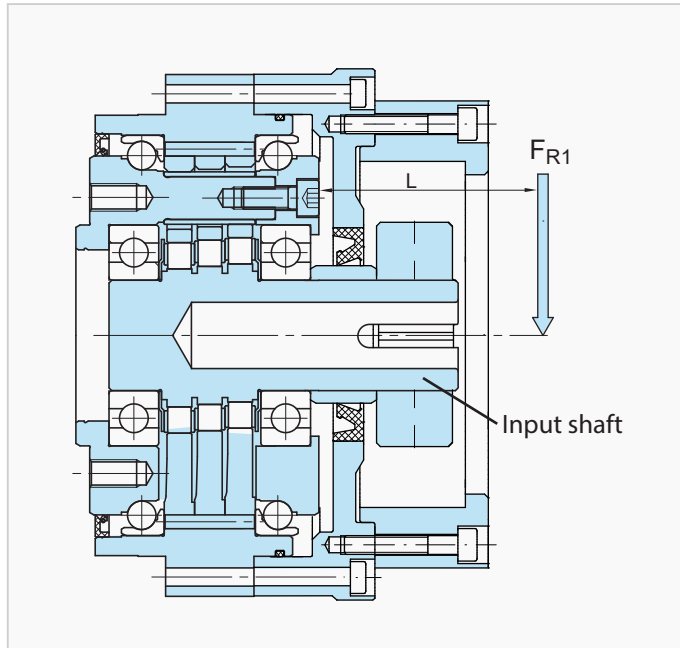

Fig. DA-4 Load position on input shaft

		Load factor input L_{f1}					
		Size					
L	[mm]	DA15	DA25	DA35	DA40	DA45	DA50
	10	0.91	0.87	0.85			
	15	0.99	0.94	0.91	0.91	0.88	
	20	1.25	1.00	0.98	0.97	0.93	0.90
	25	1.56	1.25	1.14	1.09	0.98	0.94
	30	1.88	1.50	1.36	1.30	1.11	0.99
	35	2.19	1.75	1.59	1.52	1.30	1.13
	40		2.00	1.82	1.74	1.48	1.29
	45			2.05	1.96	1.67	1.45
	50				2.17	1.85	1.61
	60					2.22	1.94
l_1	If: $L_n = 1$	16	20	22	23	27	31
a		0.072	0.063	0.061	0.055	0.052	0.046

Table DA-10 Load factor input L_{f1}

L = Distance from input side input shaft front end

$$L \geq l_1 \quad L_{f1} = L/l_1$$

$$L < l_1 \quad L_{f1} = 1.0 - a/5 \times (l_1 - L)$$

If a gear or timing belt pulley is mounted on the input shaft, the values for radial load and axial load should be equal to or less than the permissible values. The following equation is used to check whether the shaft load is permissible:

1. Input radial load F_{R1}

$$F_{R1} = 10^3 \cdot \frac{T_{2V}}{\eta \cdot i \cdot r_0} \leq \frac{F_{R1 \max}}{L_{f1} \cdot C_{f1} \cdot B_{f1}} \quad [\text{N}] \quad (\text{Equation DA-1})$$

2. Input side axial load F_{A1}

$$F_{A1} \leq \frac{F_{A1 \max}}{C_{f1} \cdot B_{f1}} \quad [\text{N}] \quad (\text{Equation DA-2})$$

3. When radial and axial loads co-exist

$$\left(\frac{F_{R1} \cdot L_{f1}}{F_{R1 \max}} + \frac{F_{A1}}{F_{A1 \max}} \right) \cdot C_{f1} \cdot B_{f1} \leq 1 \quad (\text{Equation DA-3})$$

F_{R1} = input side radial load [N]

T_{2V} = reference torque on output shaft [Nm]

r_0 = pitch circle radius of sprocket, pinion, or timing belt pulley [mm]

$F_{R1 \max}$ = maximum permissible input side radial load [N] (Table DA-12)

F_{A1} = input side axial load [N]

$F_{A1 \max}$ = max. permissible input side axial load [N] (Table DA-10)

L_{f1} = load factor input (Table DA-10)

C_{f1} = correction factor input (Table DA-9)

B_{f1} = service factor input (Table DA-11)

L = distance of radial load from front end on input side of the input shaft [mm] (Table DA-10)

η = 0.8 (efficiency)

Correction factor input	C_{f1}
Chain	1
Gear or pinion *	1.25
Timing belt	1.25
V-Belt	1.5

Table DA-9 Correction factor input C_{f1}

Service factor input	B_{f1}
Uniform load	1
Light impacts	1.2
Severe impacts	1.6

Table DA-11 Service factor input B_{f1}

* For helical pinions or bevel gears, please consult Sumitomo Drive Technologies.

Size		Input speed n_{1m} [min ⁻¹]								
		4000	3000	2500	2000	1750	1500	1000	750	600
DA15		226	245	265	284	294	314	353	392	422
DA25		334	373	392	422	441	461	530	589	628
DA35			491	520	559	589	618	706	785	844
DA40	Ratio 41			436	470	491	517	592	651	702
	Ratio > 41			573	617	645	679	777	855	921
DA45	Ratio 41			436	470	491	517	592	651	702
	Ratio > 41			608	657	687	726	824	912	981
DA50					657	687	726	824	912	981

Table DA-12 Max. permissible input side radial load $F_{R1\ max}$ [N]

$$F_{R1\ max} = F_{R1,600} \left(\frac{600}{n_{1m}} \right)^{1/3}$$

$F_{R1\ max}$ = maximum permissible input side radial load at input speed n_{1m}

$F_{R1,600}$ = Radial load on input side at input speed $n_{1m} = 600\ min^{-1}$

Size		Input speed n_{1m} [min ⁻¹]								
		4000	3000	2500	2000	1750	1500	1000	750	600
DA15		245	284	314	343	363	392	471	549	608
DA25		363	412	451	500	540	579	697	804	883
DA35			540	589	657	706	755	922	1059	1167
DA40	Ratio 41			797	886	943	1014	1227	1404	1559
	Ratio > 41			797	886	943	1014	1227	1404	1559
DA45	Ratio 41			956	1061	1130	1215	1470	1683	1869
	Ratio > 41			1010	1118	1197	1295	1570	1795	2001
DA50					1118	1197	1295	1570	1795	2001

Table DA-13 Max. permissible input side axial load $F_{A1\ max}$ [N]

$$F_{A1\ max} = F_{A1,600} \left(\frac{600}{n_{1m}} \right)^{0.47}$$

$F_{A1\ max}$ = maximum permissible input side axial load at input speed n_{1m}

$F_{A1,600}$ = Axial load on input side at input speed $n_{1m} = 600\ min^{-1}$

Sold & Serviced By:



Toll Free Phone (877) SERV098
www.electromate.com
sales@electromate.com

6.7.2 Main bearing

Fine Cyclo - F4C-DA

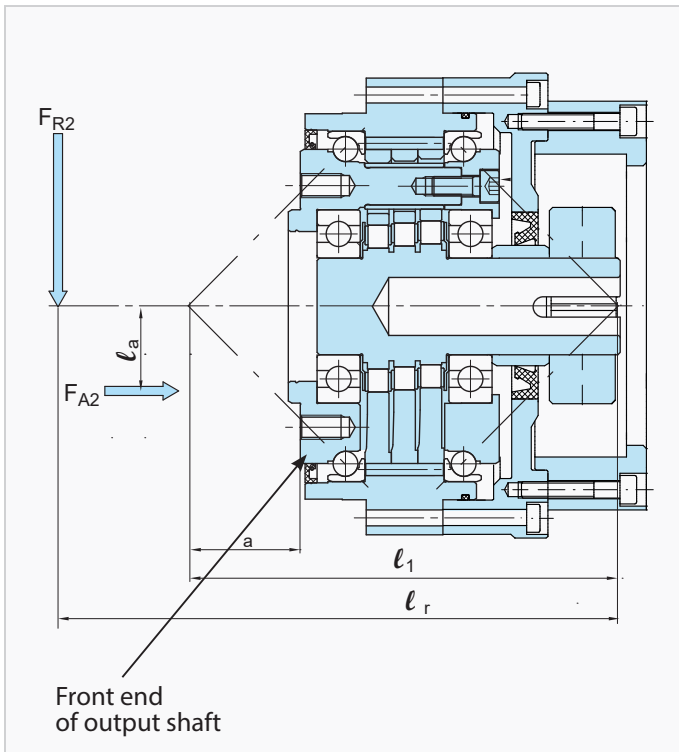

Fig. DA-5 Load position output

Size	Values of internal bearing distance	
	l ₁ [mm]	a [mm]
DA15	119	23.9
DA25	139	30.5
DA35	163	37.8
DA40	171	41.0
DA45	190	49.2
DA50	206	52.4

Table DA-14 Bearing clearances

Note If: $l_r > 4 \cdot l_1$, please contact Sumitomo Drive Technologies.

1. Moment stiffness

The moment stiffness is the bending moment at which the output flange is tilted by the tilt angle.

The tilt angle of the input flange is determined as follows:

$$\varphi_1 = \frac{T_k}{\Theta_1} \quad \text{(Equation DA-5)}$$

External bending moment T_k

$$T_k = 10^{-3} \cdot (F_{R2} \cdot l_r + F_{A2} \cdot l_a) \quad \text{(Equation DA-6)}$$

2. Max. permissible bending moment and max. permissible axial load.

Check the equivalent bending moment and the equivalent axial load using the equations DA-6, DA-7, DA-8, and Fig. DA-6.

Equivalent bending moment T_{ke}

$$T_{ke} = 10^{-3} \cdot (C_{f2} \cdot B_{f2} \cdot F_{R2} \cdot l_r + C_{f2} \cdot B_{f2} \cdot F_{A2} \cdot l_a) < T_{kmax} \quad \text{(Equation DA-7)}$$

Equivalent axial load F_{A2e} at the output shaft

$$F_{A2e} = F_{A2} \cdot C_{f2} \cdot B_{f2} < F_{A2max} \quad \text{(Equation DA-8)}$$

F_{A2} = output side axial load [N]

F_{A2max} = maximum permissible output side axial load [N]

F_{A2e} = equivalent output side axial load [N]

F_{R2} = output side radial load [N]

C_{f2} = correction factor output (Table DA-16)

B_{f2} = service factor output (Table DA-17)

l_1 = bearing clearance [mm] (Table DA-14)

l_r = calculated dimension for bending moment [mm]

l_a = distance of axial load [mm]

x = distance from radial force to flange collar [mm]

a = correction factor [mm] (Table DA-14)

T_k = external bending moment [Nm]

T_{kmax} = maximum permissible bending moment [Nm] (Table DA-18)

T_{ke} = equivalent bending moment [Nm]

φ_1 = tilt angle [arcmin]

Θ_1 = moment stiffness main bearing [Nm/arcmin] (Table DA-19)

Sold & Serviced By:



Toll Free Phone (877) SERV098

www.electromate.com

sales@electromate.com

Correction factor	C_{f2}
Chain	1
Gear or pinion	1.25
Timing belt	1.25
V-Belt	1.5

Table DA-15 Correction factor output C_{f2}

Correction factor output	C_{f2}
Chain	1
Gear or pinion	1.25
Timing belt	1.25
V-Belt	1.5

Table DA-16 Correction factor output C_{f2}

Service factor output	B_{f2}
Uniform load	1
Light impacts	1.2
Severe impacts	1.6

Table DA-17 Service factor output B_{f2}

Size	Ratio	Max. permissible bending moment $T_{k\max}$	Max. permissible axial load $F_{A2\max}$	
			Tension	Compression
		[Nm]	[N]	[N]
DA15		883	3924	3924
DA25		1660	5220	5220
DA35	29	1620	6530	6530
	41-119	2150		
DA40	41	2430	9000	9000
	59-119	2700		
DA45	29-41	3090	13000	13000
	59-119	3430		
DA50	41	3600	15000	15000
	59-119	4000		

Table DA-18 Max. permissible bending moment and max. permissible axial load

Size	Moment stiffness Θ_1
	[Nm/arcmin]
DA15	510
DA25	833
DA35	1127
DA40	1470
DA45	1500
DA50	2450

Table DA-19 Average values for moment stiffness

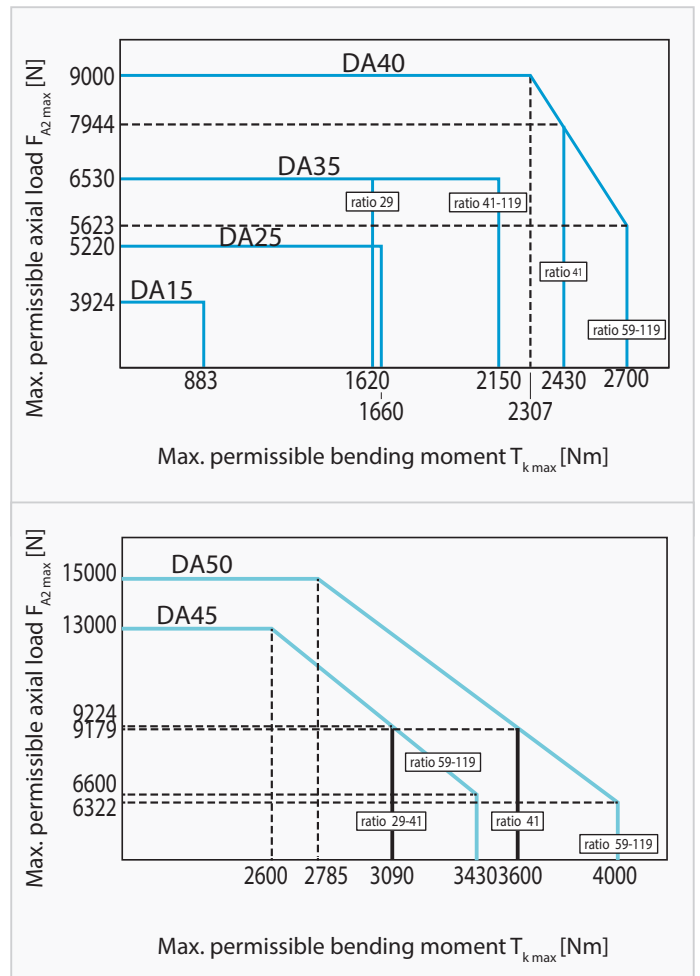

Fig. DA-6 Max. permissible bending moment and axial load

Sold & Serviced By:



Toll Free Phone (877) SERV098
www.electromate.com
sales@electromate.com

6.8 Assembly specifications and tolerances

6.8.1 Assembly tolerances

To ensure the function, lifetime, and characteristics of the gearbox, the radial run-out of the shaft ends, the coaxiality and the axial run-out of the fastening surface as per EN 50347:2001 are sufficient. When used in high-precision applications, the tolerance according to EN 50347:2001 should be reduced by 50%, which has additional advantages.

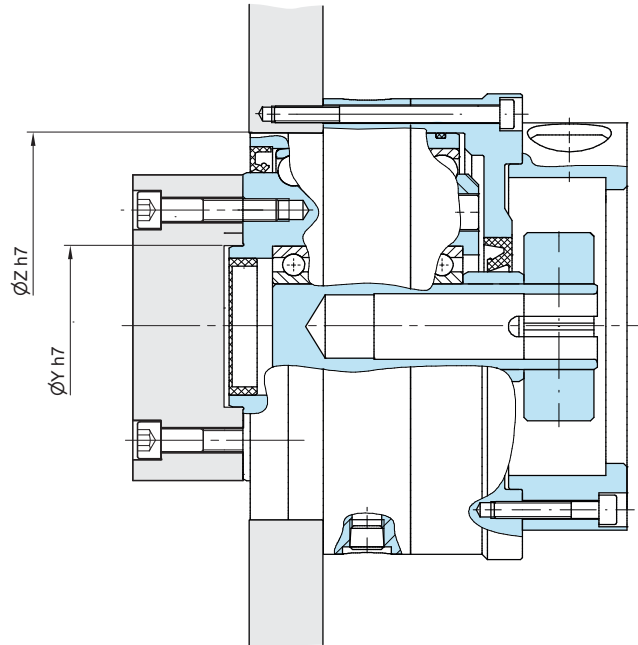

Size	$\varnothing Z$	$\varnothing Y$
DA15	113	47
DA25	136	65
DA35	160	80
DA40	170	75
DA45	186	90
DA50	202	100

Table DA-20 (Dimensions in mm)

- Take the installation situation in position ③ into consideration on the input side.
- Take the installation situation at the output flange in position ② and at the customer's housing in position ① into consideration.

Installation example 1

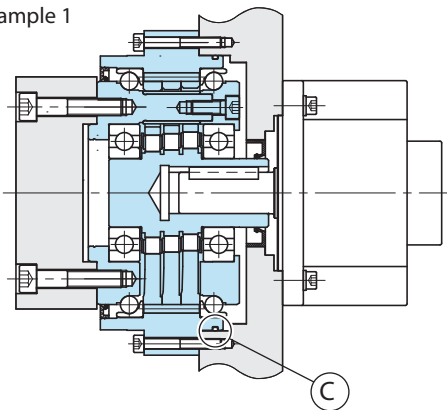

Installation example 2

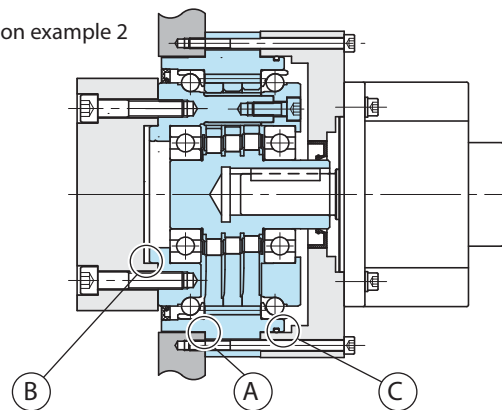

Fig. DA-7 Installation example

6.8.2 Tightening torque and maximum permissible transmittable torque for bolts

The permissible transmitted torque for bolts and the number, size, and tightening torque for fastening the output side flange and the ring gear housing are listed in Table DA-21. In the event of an Emergency Stop with corresponding load peaks, the output flange and ring gear housing bolts must all be replaced.

Size	Output flange bolts			Bolts for ring gear (housing)		
	Number and size of bolts	Tightening torque [Nm]	Max. permissible transmittable torque for bolts [Nm]	Number and size of bolts	Tightening torque [Nm]	Max. permissible transmittable torque for bolts [Nm]
DA15	12 × M8	38.3	1478	16 × M5	9.1	1389
DA25	18 × M8	38.3	2772	16 × M6	15.7	2356
DA35	16 × M10	76.5	4594	16 × M8	38.3	5073
DA40	16 × M10	76.5	5283	18 × M8	38.3	6000
DA45	18 × M10	76.5	6408	16 × M10	76.5	9371
DA50	18 × M12	133	10516	16 × M10	76.5	10106

Table DA-21

- **Bolting:** Use metric hexagon socket head screws (DIN 4762, strength category 12.9).
- **Countermeasure for bolts loosening:** Use adhesives (Loctite 262, etc.) or spring washer (DIN 127A).
- **Use spring washers** (DIN 6796) when connecting the gearbox to the flange side, so that the bolt contact faces do not get damaged.

Sold & Serviced By:
 **ELECTROMATE**
 Toll Free Phone (877) SERV098
www.electromate.com
sales@electromate.com

6.8.3 Lubrication

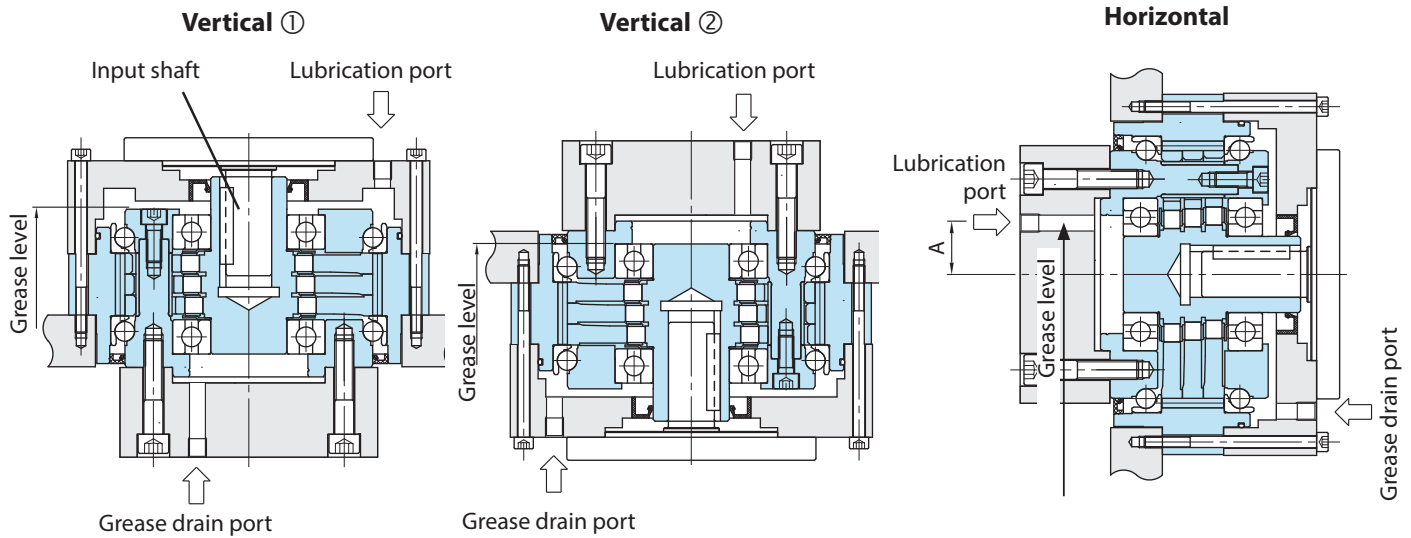

- For gearboxes that are not sealed, delivery does not include lubricant (grease filling). Upon receipt, the customer must therefore fill it with the appropriate amount (Table DA-23) of the recommended grease (Table DA-22).
- Use the quantity quoted in Table DA-23 as an approximate value; check the grease level.
- Fit the lubrication port and the grease drain on the output side. (See "A" and Table DA-23)
- When adding grease for the first time, use the lower opening to ensure grease circulation.
- Reconditioning is recommended after 20,000 operating hours, but at least every 3-5 years.
- The lifetime of the gearbox can be increased by returning it to the factory for overhauling and regreasing.
- DA-Modular as per the standard catalogue version are designed for lubrication in any mounting position.

Specified grease	Manufacturer
Multemp FZ No. 00	Kyodo Yushi Co., Ltd.
Conditions for use: Ambient temperature -10 °C to +40 °C	

Table DA-22 Specified grease

Size	Quantity of grease [g]			Lubrication port distance A [mm]
	Vertical ①	Vertical ②	Horizontal	
DA15	52	52	39	20
DA25	113	113	91	27
DA35	196	196	161	34
DA40	204	204	170	36
DA45	222	222	178	39
DA50	305	305	252	43

Table DA-23 (if delivered without grease filling)

Sold & Serviced By:



Toll Free Phone (877) SERV098
www.electromate.com
sales@electromate.com

6.8.4 Dimensioned drawings

F4CF-DA15

Mass 4.7 kg

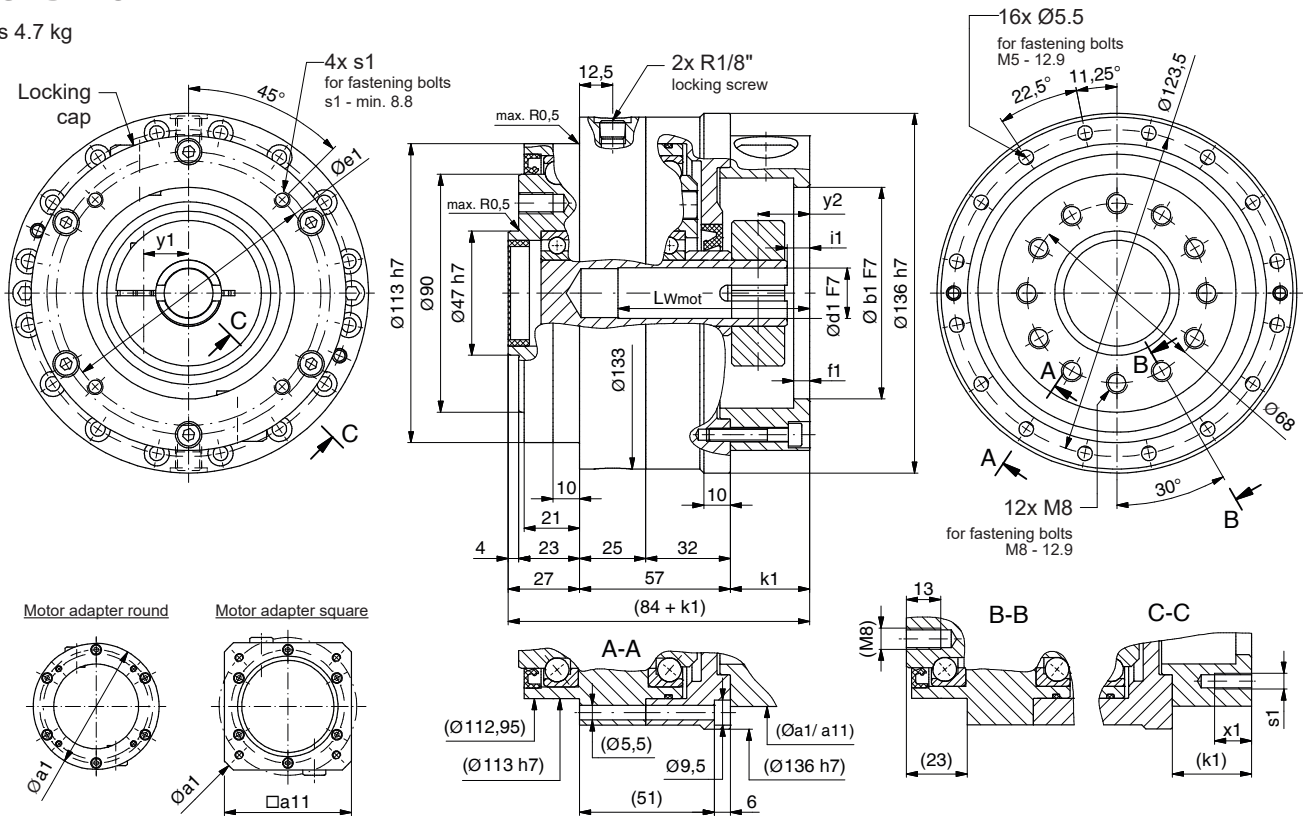

Motor mounting dimensions

Motor code	Hole for shaft	Min./Max. Length of motor shaft	Centering F7	Spigot seat depth	Pitch circle Ø	Thread in gearbox flange	Thread depth	Flange diameter	Flange square dimension	Flange width	Shaft leeway without bushing	Shaft leeway with bushing	Positional dimensions locking lid	
	Ød1	L _{wMot} min/max	Øb1	f1	Øe1	4x s1	x1	Øa1	□a11	k1	i1		y1	y2
mm														
D30G	10	25.0 / 48.5	80	6	100	M6	14	119	-	30	-	7.5	18.5	16.5
E08G	11	24.0 / 47.5	40	5.5	63	M5	7.5	119	-	29	-	6.5	17	16.5
E10G		24.0 / 47.5	50	5.5	70	M4	7.5	119	-	29	-	6.5	17	16.5
E11G		24.0 / 47.5	60	5.5	75	M5	7.5	119	-	29	-	6.5	18.5	16.5
F25G	12	24.0 / 47.5	50	5.5	70	M5	7.5	119	-	29	-	6.5	17	16.5
F17G		25.5 / 49.0	70	6	90	M5	12	119	-	30.5	-	8	18.5	17
F24G		25.0 / 48.5	73.02	6	98.4	M5	12	119	-	30	-	7.5	18.5	16.5
H10G	14	24.0 / 47.5	50	5.5	70	M4	7.5	119	-	29	-	6.5	17	16.5
H25G		24.0 / 47.5	50	5.5	70	M5	7.5	119	-	29	-	6.5	17	16.5
H20G		24.0 / 47.5	50	6	95	M6	14	119	-	29	-	6.5	17	16.5
H12G		24.0 / 47.5	60	5.5	75	M6	7.5	119	-	29	-	6.5	18.5	16.5
H18G		25.5 / 49.0	70	6	90	M6	14	119	-	30.5	-	8	18.5	17
H30L		34.0 / 57.5	80	6	100	M6	14	119	-	39	-	7.5	18.5	25.5
H35G		25.0 / 48.5	95	6	115	M8	17	138	120	30	-	7.5	18.5	18
H50G		25.0 / 48.5	110	6	130	M8	17	158	120	30	-	7.5	25	18
H60L	36.5 / 60.0	110	8	145	M8	17	158	120	41.5	-	19	25	29.5	
J18G	16	30.0 / 73.0	70	6	90	M6	14	119	-	30.5	-	8	18.5	17
J30G		29.5 / 72.5	80	6	100	M6	14	119	-	30	-	7.5	18.5	16.5
J60G		29.5 / 72.5	110	6.5	145	M8	17	158	120	30	-	7.5	25	18
K60L	17	43.0 / 84.0	110	8	145	M8	17	158	120	41.5	-	19	25	29.5
M30G	19	29.5 / 72.5	80	6	100	M6	14	119	-	30	8.5	-	18.5	16.5
M30L		38.5 / 81.5	80	6	100	M6	14	119	-	39	8.5	-	18.5	25.5
M35G		29.5 / 72.5	95	6	115	M8	17	138	120	30	8.5	-	18.5	18
M45G		29.5 / 72.5	95	6	130	M8	17	158	120	30	8.5	-	25	18
M60G		29.5 / 72.5	110	6.5	145	M8	17	158	120	30	8.5	-	25	18
M60L		43.0 / 84.0	110	8	145	M8	17	158	120	41.5	20	-	25	29.5

F4CF-DA25

Mass 7.6 kg

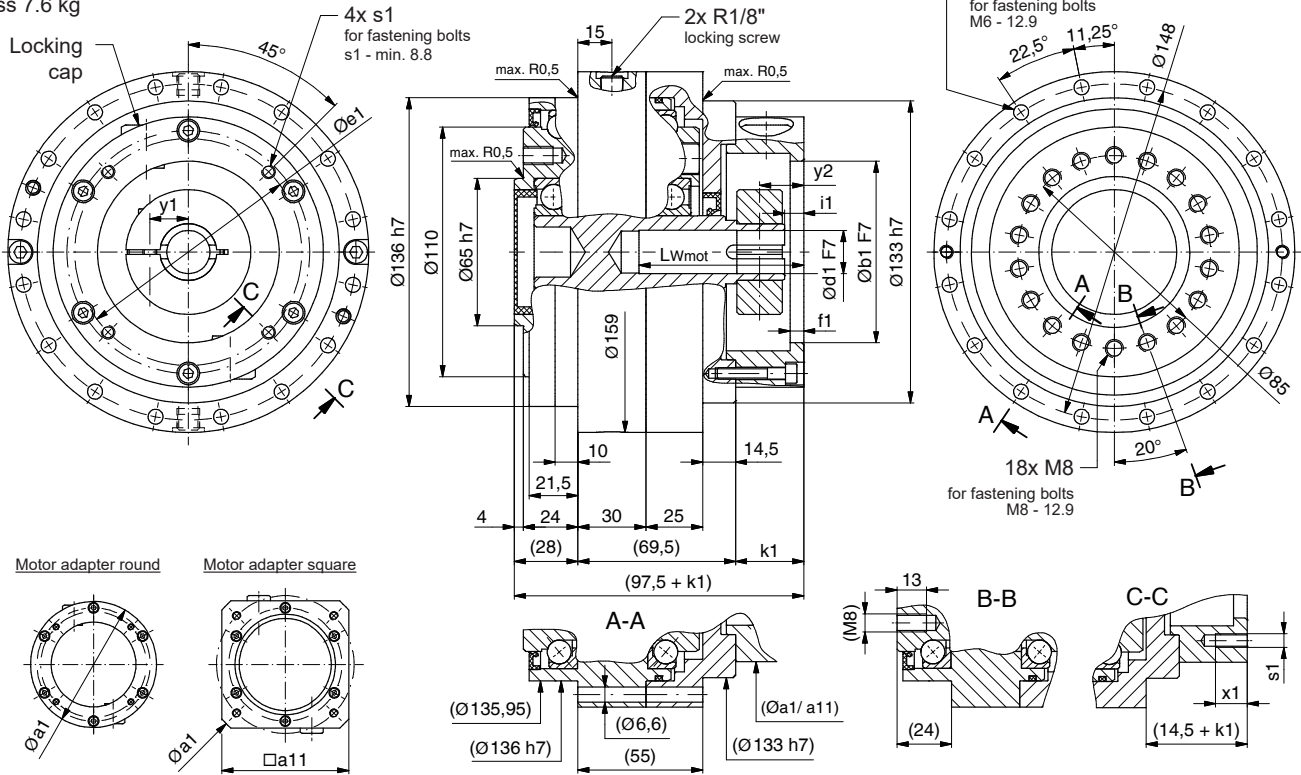

Motor mounting dimensions

Motor code	Hole for shaft	Min./Max. Length of motor shaft	Centering F7	Spigot seat depth	Pitch circle Ø	Thread in gearbox flange	Thread depth	Flange diameter	Flange square dimension	Flange width	Shaft leeway without bushing	Shaft leeway with bushing	Positional dimensions locking lid	
	Ød1	L _{Mot} min/max	Øb1	f1	Øe1	4x s1	x1	Øa1	□a11	k1	i1		y1	y2
mm														
D30G	10	25.0 / 48.5	80	6	100	M6	14	119	-	30	-	7.3	18.5	16.5
E08G	11	24.0 / 47.5	40	5.5	63	M5	7.5	119	-	29	-	6.3	17	16.5
E10G		24.0 / 47.5	50	5.5	70	M4	7.5	119	-	29	-	6.3	17	16.5
E11G		24.0 / 47.5	60	5.5	75	M5	7.5	119	-	29	-	6.3	18.5	16.5
F25G	12	24.0 / 47.5	50	5.5	70	M5	7.5	119	-	29	-	6.3	17	16.5
F17G		25.5 / 49.0	70	6	90	M5	12	119	-	30.5	-	7.8	18.5	17
F24G		25.0 / 48.5	73.02	6	98.4	M5	12	119	-	30	-	7.3	18.5	16.5
H10G	14	24.0 / 47.5	50	5.5	70	M4	7.5	119	-	29	-	6.3	17	16.5
H25G		24.0 / 47.5	50	5.5	70	M5	7.5	119	-	29	-	6.3	17	16.5
H20G		24.0 / 47.5	50	6	95	M6	14	119	-	29	-	6.3	17	16.5
H12G		24.0 / 47.5	60	5.5	75	M6	7.5	119	-	29	-	6.3	18.5	16.5
H18G		25.5 / 49.0	70	6	90	M6	14	119	-	30.5	-	7.8	18.5	17
H30L		34.0 / 57.5	80	6	100	M6	14	119	-	39	-	7.3	18.5	25.5
H35G		25.0 / 48.5	95	6	115	M8	17	138	120	30	-	7.3	18.5	18
H50G		25.0 / 48.5	110	6	130	M8	17	158	120	30	-	7.3	25	18
H60L	36.5 / 60.0	110	8	145	M8	17	158	120	41.5	-	18.8	25	29.5	
J18G	16	30.0 / 73.0	70	6	90	M6	14	119	-	30.5	-	7.8	18.5	17
J30G		29.5 / 72.5	80	6	100	M6	14	119	-	30	-	7.3	18.5	16.5
J60G		29.5 / 72.5	110	6.5	145	M8	17	158	120	30	-	7.3	25	18
K60L	17	43.0 / 84.0	110	8	145	M8	17	158	120	41.5	-	18.8	25	29.5
M30G	19	29.5 / 72.5	80	6	100	M6	14	119	-	30	-	7.3	18.5	16.5
M30L		38.5 / 81.5	80	6	100	M6	14	119	-	39	-	7.3	18.5	25.5
M35G		29.5 / 72.5	95	6	115	M8	17	138	120	30	-	7.3	18.5	18
M45G		29.5 / 72.5	95	6	130	M8	17	158	120	30	-	7.3	25	18
M60G		29.5 / 72.5	110	6.5	145	M8	17	158	120	30	-	7.3	25	18
M60L		43.0 / 84.0	110	8	145	M8	17	158	120	41.5	-	18.8	25	29.5
N60G	22	31.5 / 72.5	110	6.5	145	M8	17	158	120	30	-	7.3	25	18
Z35G	24	31.5 / 72.5	95	6	115	M8	17	138	120	30	8.5	-	18.5	18
Z50G		31.5 / 72.5	110	6	130	M8	17	158	120	30	8.5	-	25	18
Z70G		31.5 / 72.5	130	6	165	M10	20	188	144	30	8.5	-	25	18

F4CF-DA35

Mass 11.8 kg

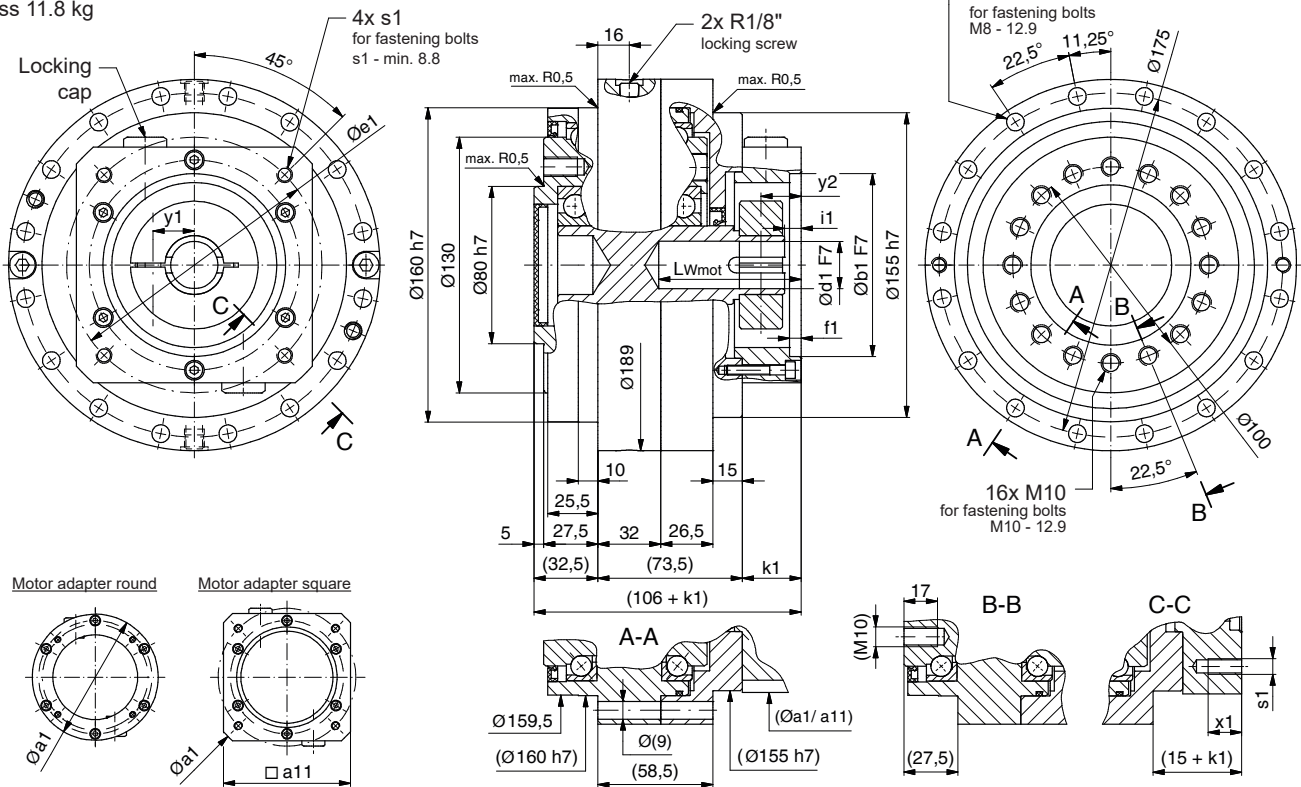

Motor mounting dimensions

Motor code	Hole for shaft Ød1	Min./Max. Length of motor shaft L _{wMot} min/max	Centering F7 Øb1	Spigot seat depth f1	Pitch circle Ø Øe1	Thread in gearbox flange 4x s1	Thread depth x1	Flange diameter Øa1	Flange square dimension □a11	Flange width k1	Shaft leeway		Positional dimensions locking lid	
											without bushing i1	with bushing	y1	y2
mm														
H35G	14	25.0 / 48.5	95	6	115	M8	17	138	120	30	-	7.3	18.5	18
H50G		25.0 / 48.5	110	6	130	M8	17	158	120	30	-	7.3	25	18
H60L		36.5 / 60.0	110	8	145	M8	17	158	120	41.5	-	18.8	25	29.5
J18G	16	30.0 / 73.0	70	6	90	M6	14	119	-	30.5	-	7.8	18.5	17
J30G		29.5 / 72.5	80	6	100	M6	14	119	-	30	-	7.3	18.5	16.5
J60G		29.5 / 72.5	110	6.5	145	M8	17	158	120	30	-	7.3	25	18
K60L	17	43.0 / 84.0	110	8	145	M8	17	158	120	41.5	-	18.8	25	29.5
M30G	19	29.5 / 72.5	80	6	100	M6	14	119	-	30	-	7.3	18.5	16.5
M30L		38.5 / 81.5	80	6	100	M6	14	119	-	39	-	7.3	18.5	25.5
M35G		29.5 / 72.5	95	6	115	M8	17	138	120	30	-	7.3	18.5	18
M45G		29.5 / 72.5	95	6	130	M8	17	158	120	30	-	7.3	25	18
M60G		29.5 / 72.5	110	6.5	145	M8	17	158	120	30	-	7.3	25	18
M60L		43.0 / 84.0	110	8	145	M8	17	158	120	41.5	-	18.8	25	29.5
N60G	22	31.5 / 72.5	110	6.5	145	M8	17	158	120	30	-	7.3	25	18
Z35G	24	31.5 / 72.5	95	6	115	M8	17	138	120	30	-	-	18.5	18
Z50G		31.5 / 72.5	110	6	130	M8	17	158	120	30	-	-	25	18
Z70G		31.5 / 72.5	130	6	165	M10	20	188	144	30	-	-	25	18
Q50G	28	31.5 / 88.5	110	6	130	M8	17	158	120	30	-	7.5	25	18
Q60G		31.5 / 88.5	110	6.5	145	M8	17	158	120	30	-	7.5	25	18
Q60L		43.0 / 100.0	110	8	145	M8	17	158	120	41.5	-	19	25	29.5
Q70G		31.5 / 88.5	130	6	165	M10	20	188	144	30	-	7.5	25	18
S70G	32	31.5 / 88.5	130	6	165	M10	20	188	144	30	8.5	-	25	18

F4CF-DA40

Mass 13.9 kg

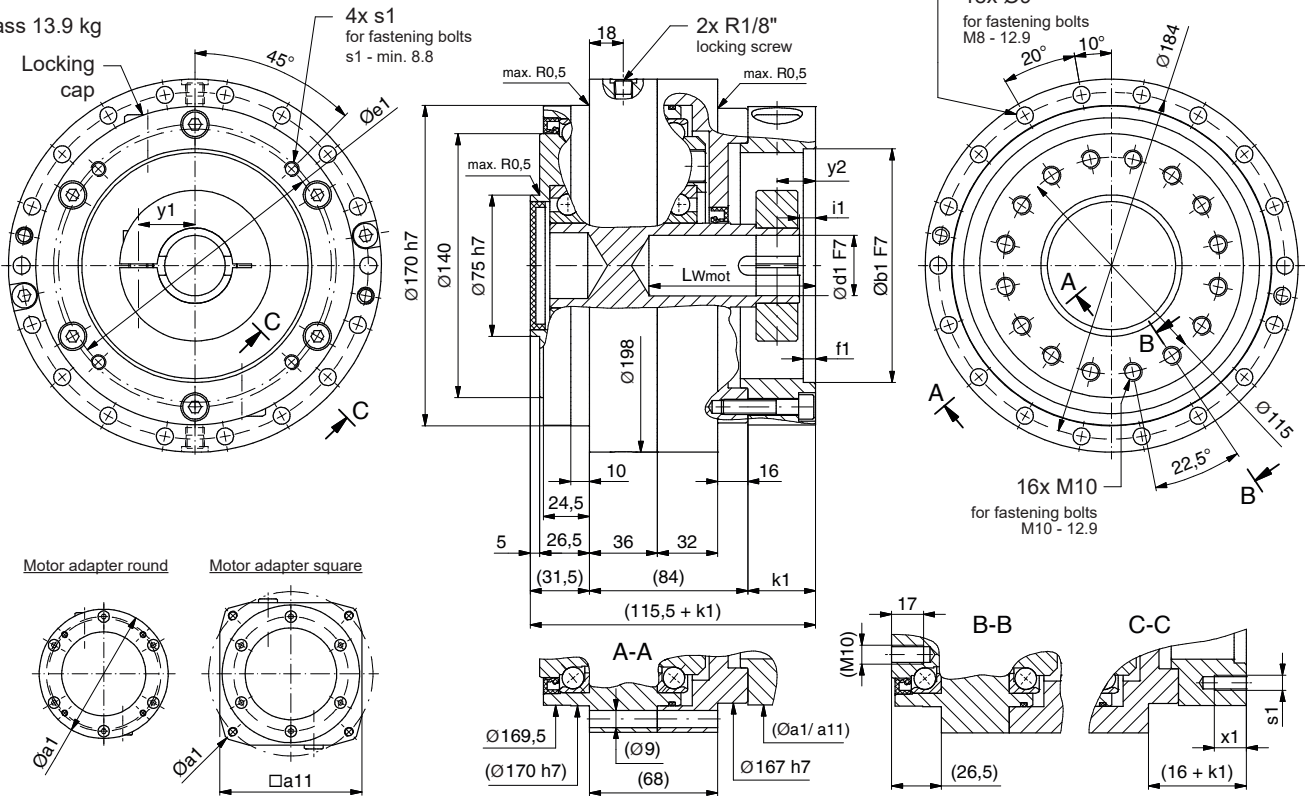

Motor adapter round Motor adapter square

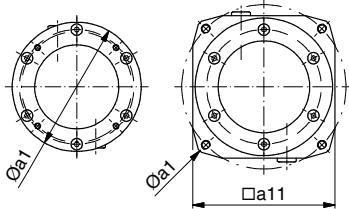

Motor mounting dimensions

Motor code	Hole for shaft	Min./Max. Length of motor shaft	Centering F7	Spigot seat depth	Pitch circle Ø	Thread in gearbox flange	Thread depth	Flange diameter	Flange square dimension	Flange width	Shaft leeway without bushing	Shaft leeway with bushing	Positional dimensions locking lid	
	Ød1	L _{w Mot. min/max}	Øb1	f1	Øe1	4x s1	x1	Øa1	□a11	k1	i1		y1	y2
mm														
H35G	14	25.0 / 48.5	95	6	115	M8	17	138	120	30	-	7.3	18.5	18
H50G		25.0 / 48.5	110	6	130	M8	17	158	120	30	-	7.3	25	18
H60L		36.5 / 60.0	110	8	145	M8	17	158	120	41.5	-	18.8	25	29.5
J18G	16	30.0 / 73.0	70	6	90	M6	14	119	-	30.5	-	7.8	18.5	17
J30G		29.5 / 72.5	80	6	100	M6	14	119	-	30	-	7.3	18.5	16.5
J60G		29.5 / 72.5	110	6.5	145	M8	17	158	120	30	-	7.3	25	18
K60L	17	43.0 / 84.0	110	8	145	M8	17	158	120	41.5	-	18.8	25	29.5
M30G	19	29.5 / 72.5	80	6	100	M6	14	119	-	30	-	7.3	18.5	16.5
M30L		38.5 / 81.5	80	6	100	M6	14	119	-	39	-	7.3	18.5	25.5
M35G		29.5 / 72.5	95	6	115	M8	17	138	120	30	-	7.3	18.5	18
M45G		29.5 / 72.5	95	6	130	M8	17	158	120	30	-	7.3	25	18
M60G		29.5 / 72.5	110	6.5	145	M8	17	158	120	30	-	7.3	25	18
M60L		43.0 / 84.0	110	8	145	M8	17	158	120	41.5	-	18.8	25	29.5
N60G	22	31.5 / 72.5	110	6.5	145	M8	17	158	120	30	-	7.3	25	18
Z35G	24	31.5 / 72.5	95	6	115	M8	17	138	120	30	-	-	18.5	18
Z50G		31.5 / 72.5	110	6	130	M8	17	158	120	30	-	-	25	18
Z70G		31.5 / 72.5	130	6	165	M10	20	188	144	30	-	-	25	18
Q50G	28	31.5 / 88.5	110	6	130	M8	17	158	120	30	-	7.3	25	18
Q60G		31.5 / 88.5	110	6.5	145	M8	17	158	120	30	-	7.3	25	18
Q60L		43.0 / 100.0	110	8	145	M8	17	158	120	41.5	-	18.8	25	29.5
Q70G		31.5 / 88.5	130	6	165	M10	20	188	144	30	-	7.3	25	18
S70G	32	31.5 / 88.5	130	6	165	M10	20	188	144	30	8.5	-	25	18

F4CF-DA45

Mass 17.8 kg

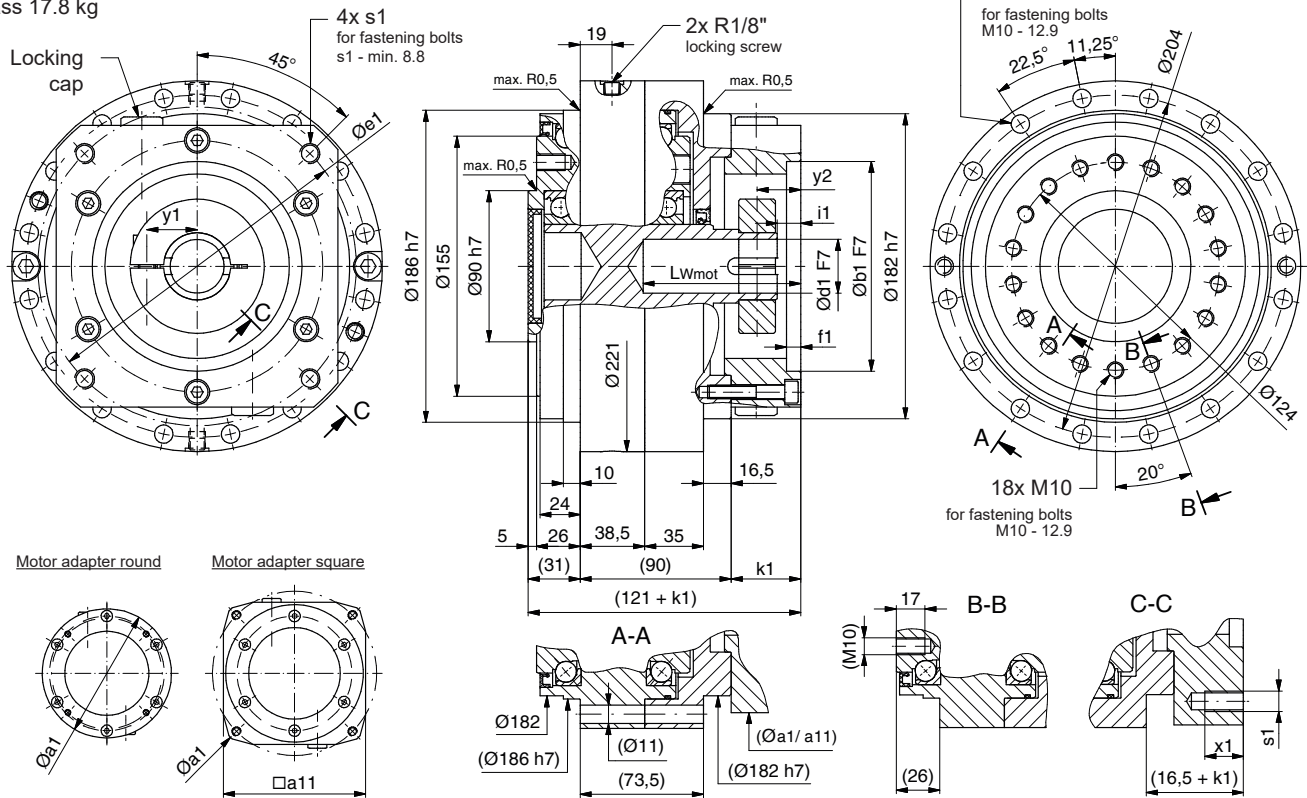

Motor mounting dimensions

Motor code	Hole for shaft	Min./Max. Length of motor shaft	Centering F7	Spigot seat depth	Pitch circle Ø	Thread in gearbox flange	Thread depth	Flange diameter	Flange square dimension	Flange width	Shaft leeway without bushing	Shaft leeway with bushing	Positional dimensions locking lid	
	Ød1	L _{wMot} min/max	Øb1	f1	Øe1	4x s1	x1	Øa1	□a11	k1	i1		y1	y2
mm														
H35G	14	29.5 / 72.5	95	6	115	M8	17	169	-	36	-	7.3	24	20.5
H50G		29.5 / 72.5	110	6	130	M8	17	169	-	36	-	7.3	24	20.5
H60L		41.0 / 84.0	110	6	145	M8	17	169	-	47.5	-	18.8	25	32
J18G	16	30.0 / 73.0	70	9	90	M5	12	169	-	36.5	-	7.8	18.5	20
J30G		29.5 / 72.5	80	6	100	M6	14	169	-	36	-	7.3	24	20.5
J60G		29.5 / 72.5	110	6	145	M8	17	169	-	36	-	7.3	25	20.5
K60L	17	41.0 / 84.0	110	6	145	M8	17	169	-	47.5	-	18.8	25	32
M30G	19	29.5 / 72.5	80	6	100	M6	9	169	-	36	-	7.3	24	20.5
M33G		29.5 / 72.5	80	6	100	M8	12	169	-	36	-	7.3	24	20.5
M35G		29.5 / 72.5	95	6	115	M8	17	169	-	36	-	7.3	24	20.5
M45G		29.5 / 72.5	95	6	130	M8	17	169	-	36	-	7.3	24	20.5
M50G		29.5 / 72.5	110	6	130	M8	17	169	-	36	-	7.3	24	20.5
M60G		29.5 / 72.5	110	6	145	M8	17	169	-	36	-	7.3	25	20.5
M60L		41.0 / 84.0	110	6	145	M8	17	169	-	47.5	-	18.8	25	32
M70G		29.5 / 72.5	130	8	165	M10	20	188	-	36	-	7.3	25	20.5
N60G	22	29.5 / 72.5	110	6	145	M8	17	169	-	36	-	7.3	25	20.5
Z35G	24	29.5 / 72.5	95	6	115	M8	17	169	-	36	-	-	24	20.5
Z50G		29.5 / 72.5	110	6	130	M8	17	169	-	36	-	-	24	20.5
Z70G		29.5 / 72.5	130	8	165	M10	20	188	-	36	-	-	25	20.5
Q60G	28	31.5 / 88.5	110	6	145	M8	17	169	-	36	-	7.3	25	20.5
Q60L		41.0 / 100	110	6	145	M8	17	169	-	47.5	-	18.8	25	32
Q70G		31.5 / 88.5	130	8	165	M10	20	188	-	36	-	7.3	25	20.5
R50G	30	31.5 / 88.5	110	6	130	M8	17	169	-	36	-	7.3	24	20.5
S70G	32	31.5 / 88.5	130	8	165	M10	20	188	-	36	-	-	25	20.5
T76G	35	37.0 / 94.0	114.3	6	200	M12	23	223	176	41.5	-	12.8	33	26.5
U80G	38	32.0 / 89.0	180	6.5	215	M12	23	237	186	36.5	9	-	30	21.5

F4CF-DA50

Mass 22.3 kg

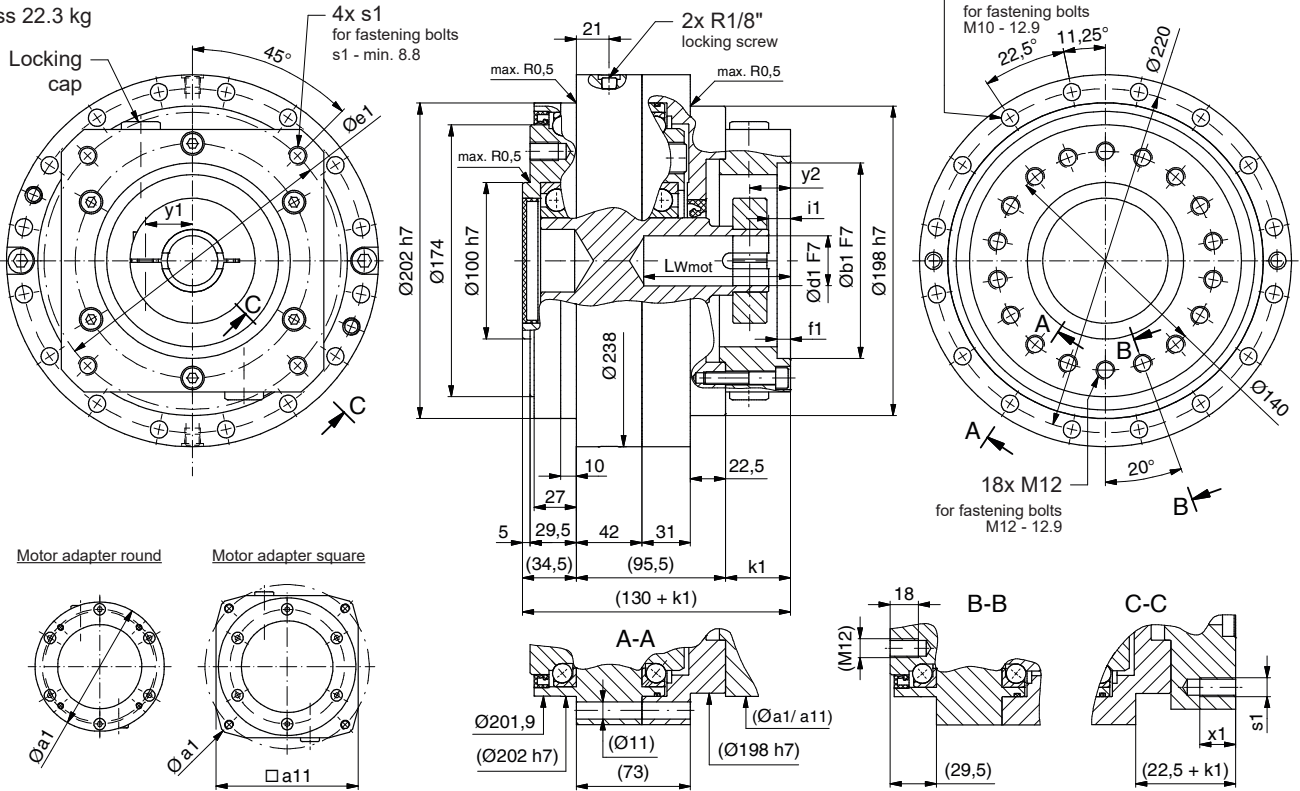

Motor mounting dimensions

Motor code	Hole for shaft Ød1	Min./Max. Length of motor shaft L _{w Mot. min/max}	Centering F7 Øb1	Spigot seat depth f1	Pitch circle Ø Øe1	Thread in gearbox flange 4x s1	Thread depth x1	Flange diameter Øa1	Flange square dimension □a11	Flange width k1	Shaft leeway		Positional dimensions locking lid	
											without bushing i1	with bushing i1	y1	y2
mm														
H35G	14	29.5 / 72.5	95	6	115	M8	17	169	-	36	-	7.3	24	20.5
H50G		29.5 / 72.5	110	6	130	M8	17	169	-	36	-	7.3	24	20.5
H60L		41.0 / 84.0	110	6	145	M8	17	169	-	47.5	-	18.8	25	32
J18G	16	30.0 / 73.0	70	9	90	M5	12	169	-	36.5	-	7.8	18.5	20
J30G		29.5 / 72.5	80	6	100	M6	14	169	-	36	-	7.3	24	20.5
J60G		29.5 / 72.5	110	6	145	M8	17	169	-	36	-	7.3	25	20.5
K60L	17	41.0 / 84.0	110	6	145	M8	17	169	-	47.5	-	18.8	25	32
M30G	19	29.5 / 72.5	80	6	100	M6	9	169	-	36	-	7.3	24	20.5
M33G		29.5 / 72.5	80	6	100	M8	12	169	-	36	-	7.3	24	20.5
M35G		29.5 / 72.5	95	6	115	M8	17	169	-	36	-	7.3	24	20.5
M45G		29.5 / 72.5	95	6	130	M8	17	169	-	36	-	7.3	24	20.5
M50G		29.5 / 72.5	110	6	130	M8	17	169	-	36	-	7.3	24	20.5
M60G		29.5 / 72.5	110	6	145	M8	17	169	-	36	-	7.3	25	20.5
M60L		41.0 / 84.0	110	6	145	M8	17	169	-	47.5	-	18.8	25	32
M70G		29.5 / 72.5	130	8	165	M10	20	188	-	36	-	7.3	25	20.5
N60G	22	29.5 / 72.5	110	6	145	M8	17	169	-	36	-	7.3	25	20.5
Z35G	24	29.5 / 72.5	95	6	115	M8	17	169	-	36	-	-	24	20.5
Z50G		29.5 / 72.5	110	6	130	M8	17	169	-	36	-	-	24	20.5
Z70G		29.5 / 72.5	130	8	165	M10	20	188	-	36	-	-	25	20.5
Q60G	28	31.5 / 88.5	110	6	145	M8	17	169	-	36	-	7.3	25	20.5
Q60L		41.0 / 100	110	6	145	M8	17	169	-	47.5	-	18.8	25	32
Q70G		31.5 / 88.5	130	8	165	M10	20	188	-	36	-	7.3	25	20.5
R50G	30	31.5 / 88.5	110	6	130	M8	17	169	-	36	-	7.3	24	20.5
S70G	32	31.5 / 88.5	130	8	165	M10	20	188	-	36	-	-	25	20.5
T76G	35	37.0 / 94.0	114.3	6	200	M12	23	223	176	41.5	-	12.8	33	26.5
U80G	38	32.0 / 89.0	180	6.5	215	M12	23	237	186	36.5	9	-	30	21.5

Sold & Serviced By:



Toll Free Phone (877) SERV098
www.electromate.com
sales@electromate.com

7 C-Series

F4C(F)-C

F2CF-C

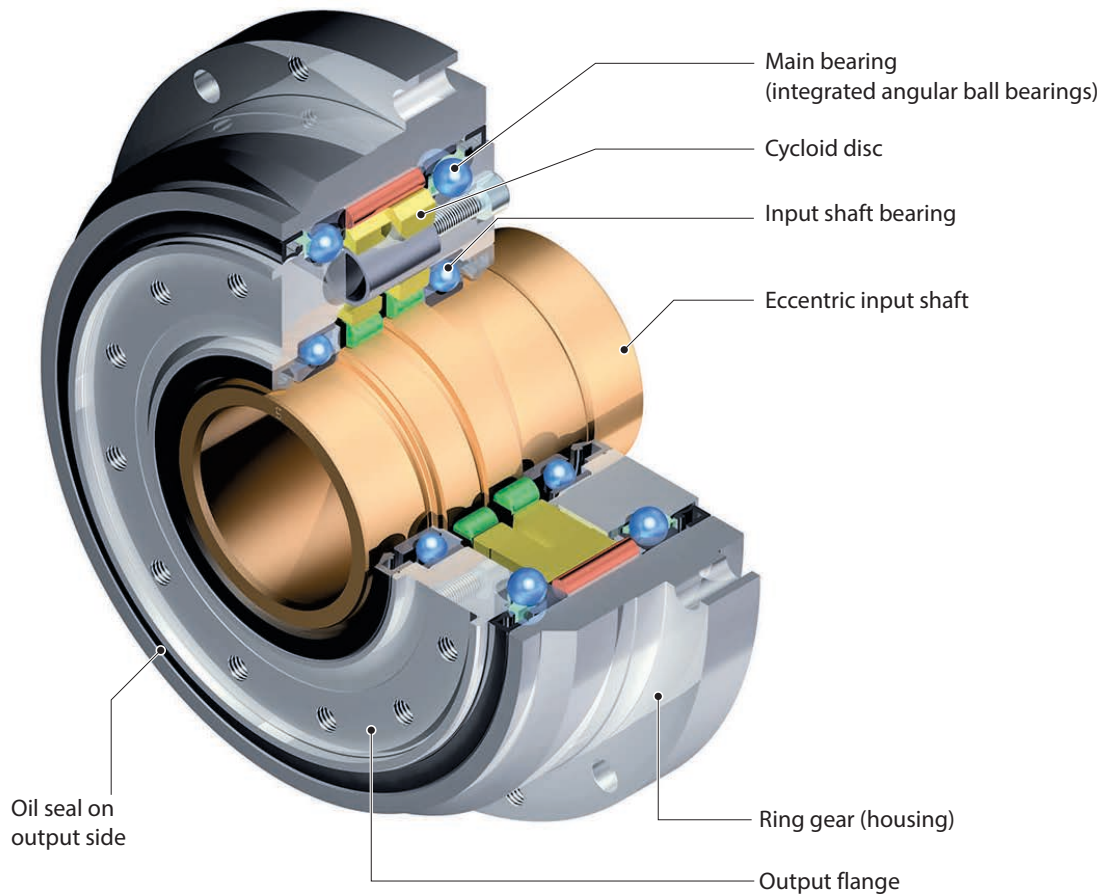

Special feature:

The large diameter of the hollow shaft allows for effective use of space for the cable or media

- 6 sizes
- Ratios (single-stage) 29/59/89/119
- Nominal output torques up to 4328 Nm
- Acceleration torques up to 6278 Nm
- Hollow shaft diameter from 40 to 99 mm
- Completely sealed and maintenance-free
- Lost Motion < 1

Sold & Serviced By:

 **ELECTROMATE**

Toll Free Phone (877) SERV098

www.electromate.com
sales@electromate.com

7.1 Torques according to output speeds

Output speed n_{2m} [min ⁻¹]			5			10			15			20		
Model	Size	Reduction ratio i	Nominal output torque [Nm]	Input speed [min ⁻¹]	Max. permissible input power [kW]	Nominal output torque [Nm]	Input speed [min ⁻¹]	Max. permissible input power [kW]	Nominal output torque [Nm]	Input speed [min ⁻¹]	Max. permissible input power [kW]	Nominal output torque [Nm]	Input speed [min ⁻¹]	Max. permissible input power [kW]
F4CF-	C15	29	276	145	0.19	276	290	0.39	276	435	0.58	276	580	0.77
		59	296	295	0.21	296	590	0.41	263	885	0.55	242	1180	0.67
		89	296	445	0.21	263	890	0.37	233	1335	0.49	214	1780	0.6
		119	296	595	0.21	241	1190	0.34	213	1785	0.45	196	2380	0.55
F4C-	C25	59	568	295	0.4	568	590	0.79	505	885	1.06	464	1180	1.29
		89	568	445	0.4	505	890	0.7	447	1335	0.94	410	1780	1.14
		119	568	595	0.4	463	1190	0.65	410	1785	0.86	376	2380	1.05
F4CF-	C35	59	1082	295	0.76	1082	590	1.51	963	885	2.02	883	1180	2.47
		89	1082	445	0.76	961	890	1.34	851	1335	1.78	781	1780	2.18
		119	1082	595	0.76	881	1190	1.23	780	1785	1.63	716	2380	2
F2CF-	C45	59	1758	295	1.23	1758	590	2.45	1565	885	3.28	1435	1180	4.01
		89	1758	445	1.23	1562	890	2.18	1383	1335	2.90	1269	1780	3.54
		119	1758	595	1.23	1432	1190	2	1268	1785	2.65			
	C55	59	2705	295	1.89	2705	590	3.78	2407	885	5.04	2208	1180	6.17
		89	2705	445	1.89	2403	890	3.36	2128	1335	4.46			
		119	2705	595	1.89	2203	1190	3.08						
	C65	59	4328	295	3.02	4328	590	6.04	3852	885	8.07	3533	1180	9.87
		89	4328	445	3.02	3845	890	5.37	3405	1335	7.13			
		119	4328	595	3.02	3524	1190	4.92						

Table C-1 Rating values (reference value output speed n_{2m})

Size	Max. acceleration and deceleration torque T_{2A}	Peak torque for Emergency Stop T_{2max}
	[Nm]	[Nm]
C15	540	1080
C25	1030	2060
C35	1962	3924
C45	3188	6377
C55	4316	8633
C65	6278	12577

Table C-2 Maximum acceleration and peak torque

25			30			Max. permissible input speed $n_{1\max}$ short term [min^{-1}]	Max. permissible input speed $n_{1\text{ED}}$ [min^{-1}]		Moment of inertia J related to the input shaft [$\times 10^{-4} \text{kgm}^2$]	Mass [kg]
Nominal output torque [Nm]	Input speed [min^{-1}]	Max. permissible input power [kW]	Nominal output torque [Nm]	Input speed [min^{-1}]	Max. permissible input power [kW]		50% ED	100% ED		
261	725	0.91	247	870	1.03	3350	2400	1200	3.52	6
226	1475	0.79	214	1770	0.9	4000	3200	1600	3.51	
200	2225	0.7	189	2670	0.79				3.5	
183	2975	0.64							3.49	
434	1475	1.51	411	1770	1.72	3500	2900	1450	8.2	12.5
383	2225	1.34	363	2670	1.52				8.2	
									8.2	
826	1475	2.88	782	1770	3.28	2500	2100	1050	32.8	21
									32.7	
									32.7	
1342	1475	4.69	1271	1770	5.32	2100	1800	900	69.6	32
									69.4	
									69.3	
2065	1475	7.21				1800	1500	750	129.4	45
									129.0	
									128.8	
						1700	1400	700	223.6	62
									222.9	
									222.6	

: 50% ED range

: 100% ED range

- T_{2N} = nominal output torque
Nominal output torque corresponds to the max. permissible average load torque at all output speeds.
The nominal output torque for speeds less than 5 min^{-1} is equal to the value at 5 min^{-1} .
The value for the maximum permissible input power is calculated from the nominal output torque at 100%.
This value takes the efficiency of Fine Cyclo into consideration.
- $n_{1\max}$ = maximum permissible input speed
However, it must be n_{1m} (mean input speed) $< n_{1\text{ED}}$.
- $n_{1\text{ED}}$ = permissible input speed according to duty cycle
- T_{2A} = max. Acceleration and braking torque (for fatigue strength at $2 \cdot 10^7$ load cycles)
Permissible peak torque for normal start and stop procedures.
- $T_{2\max}$ = max. permissible torque for Emergency Stop situations or in the event of heavy shocks (limited by the mechanical strength)
(permissible 1000 times during the entire lifetime).
- The rated torque T_{2N} is calculated using the following equation when the speed is not shown in the table above:

$$T_{2N} = T_{2N,600} \left(\frac{600}{n_{1m}} \right)^{0.3}$$

T_{2N} : Rated torque at input speed n_{1m}
 $T_{2N,600}$: Rated torque at input speed n_{1m} is 600 min^{-1}

7.2 Torques according to input speeds

Input speed n_{1m} [min ⁻¹]			2500			2000			1750			1500			
Model	Size	Reduction ratio i	Nominal output torque [Nm]	Output speed [min ⁻¹]	Max. permissible input power [kW]	Nominal output torque [Nm]	Output speed [min ⁻¹]	Max. permissible input power [kW]	Nominal output torque [Nm]	Output speed [min ⁻¹]	Max. permissible input power [kW]	Nominal output torque [Nm]	Output speed [min ⁻¹]	Max. permissible input power [kW]	
F4CF-	C15	29	180	86.2	2.17	192	69	1.85	200	60.3	1.69	210	51.7	1.51	
		59	193	42.4	1.14	206	33.9	0.98	215	29.7	0.89	225	25.4	0.8	
		89	193	28.1	0.76	206	22.5	0.65	215	19.7	0.59	225	16.9	0.53	
		119	193	21	0.57	206	16.8	0.48	215	14.7	0.44	225	12.6	0.4	
F4C-	C25	59	370	42.4	2.19	396	33.9	1.87	412	29.7	1.7	432	25.4	1.53	
		89	370	28.1	1.45	396	22.5	1.24	412	19.7	1.13	432	16.9	1.01	
		119	370	21	1.08	396	16.8	0.93	412	14.7	0.84	432	12.6	0.76	
F4CF-	C35	59				754	33.9	3.56	785	29.7	3.24	822	25.4	2.91	
		89				754	22.5	2.36	785	19.7	2.15	822	16.9	1.93	
		119				754	16.8	1.77	785	14.7	1.61	822	12.6	1.44	
F2CF-	C45	59							1275	29.7	5.27	1336	25.4	4.73	
		89							1275	19.7	3.5	1336	16.9	3.14	
		119							1275	14.7	2.61	1336	12.6	2.35	
	C55	59											2055	25.4	7.28
		89											2055	16.9	4.83
		119											2055	12.6	3.61
	C65	59													
		89													
		119													

Table C-3 Rating values (reference value input speed n_{1m})

Size	Max. acceleration and deceleration torque T_{2A}	Peak torque for Emergency Stop T_{2max}
	[Nm]	[Nm]
C15	540	1080
C25	1030	2060
C35	1962	3924
C45	3188	6377
C55	4316	8633
C65	6278	12577

Table C-4 Maximum acceleration and peak torque

1000			750			< 600			Max. permissible input speed $n_{1\max}$ short term [min ⁻¹]	Max. permissible input speed n_{1ED} [min ⁻¹]		Moment of inertia j related to the input shaft [$\times 10^{-4}$ kgm ²]	Mass [kg]			
Nominal output torque [Nm]	Output speed [min ⁻¹]	Max. permissible input power [kW]	Nominal output torque [Nm]	Output speed [min ⁻¹]	Max. permissible input power [kW]	Nominal output torque [Nm]	Output speed [min ⁻¹]	Max. permissible input power [kW]		50% ED	100% ED					
237	34.5	1.14	258	25.9	0.93	276	21	0.8	3350	2400	1200	3.52	6			
254	16.9	0.6	277	12.7	0.49	296	10	0.42				3.51				
254	11.2	0.4	277	8.4	0.33	296	7	0.28				4000		3200	1600	3.5
254	8.4	0.3	277	6.3	0.24	296	5	0.21				3.49				
487	16.9	1.15	531	12.7	0.94	568	10.2	0.81	3500	2900	1450	8.3	12.5			
487	11.2	0.76	531	8.4	0.62	568	6.7	0.53				8.2				
487	8.4	0.57	531	6.3	0.47	568	5	0.4				8.2				
928	16.9	2.19	1012	12.7	1.79	1082	10.2	1.53	2500	2100	1050	32.8	21			
928	11.2	1.45	1012	8.4	1.19	1082	6.7	1.02				32.7				
928	8.4	1.09	1012	6.3	0.89	1082	5	0.76				32.7				
1508	16.9	3.56	1644	12.7	2.91	1758	10.2	2.49	2100	1800	900	69.6	32			
1508	11.2	2.36	1644	8.4	1.93	1758	6.7	1.65				69.4				
1508	8.4	1.77	1644	6.3	1.44	1758	5	1.24				69.3				
2321	16.9	5.48	2530	12.7	4.48	2705	10.2	3.83	1800	1500	750	129.4	45			
2321	11.2	3.63	2530	8.4	2.97	2705	6.7	2.54				129.0				
2321	8.4	2.72	2530	6.3	2.22	2705	5	1.9				128.8				
3713	16.9	8.77	4048	12.7	7.17	4328	10.2	6.14	1700	1400	700	223.6	62			
3713	11.2	5.82	4048	8.4	4.75	4328	6.7	4.07				222.9				
3713	8.4	4.35	4048	6.3	3.56	4328	5	3.04				222.6				

: 50% ED range

: 100% ED range

- T_{2N} = nominal output torque
Nominal output torque corresponds to the max. permissible average load torque at all input speeds.
The nominal output torque for speeds less than 600 min⁻¹ is equal to the value at 600 min⁻¹.
The value for the maximum permissible input power is calculated from the nominal output torque at 100%.
This value takes the efficiency of Fine Cyclo into consideration.
- $n_{1\max}$ = maximum permissible input speed
However, it must be n_{1m} (mean input speed) < n_{1ED} .
- n_{1ED} = permissible input speed according to duty cycle
- T_{2A} = max. Acceleration and braking torque (for fatigue strength at $2 \cdot 10^7$ load cycles)
Permissible peak torque for normal start and stop procedures.
- $T_{2\max}$ = max. permissible torque for Emergency Stop situations or in the event of heavy shocks (limited by the mechanical strength) (permissible 1000 times during the entire lifetime).
- The rated torque T_{2N} is calculated using the following equation when the speed is not shown in the table above:

$$T_{2N} = T_{2N,600} \left(\frac{600}{n_{1m}} \right)^{0.3}$$

T_{2N} : Rated torque at input speed n_{1m}
 $T_{2N,600}$: Rated torque at input speed n_{1m} is 600 min⁻¹

7.3 Stiffness and Lost Motion

Size	i	Test torque T_p [Nm]	Lost Motion		Torsional stiffness 3% - 50% T_p [Nm/arcmin]	Torsional stiffness 3% - 100% T_p [Nm/arcmin]	Torsional stiffness 50% - 100% T_p [Nm/arcmin]												
			Lost Motion [arcmin]	Domain of definition [Nm]															
C15	29	±215	< 1	±6.5	40	69	77												
	59																		
	89																		
	119																		
C25	59	±412		< 1				±12.4	71	115	128								
	89																		
	119																		
C35	59	±785						< 1				±23.5	200	259	294				
	89																		
	119																		
C45	59	±1275										< 1				±38.3	353	404	491
	89																		
	119																		
C55	59	±1962	< 1		±58.9	588	635									687			
	89																		
	119																		
C65	59	±3139		< 1	±94.2				765	918	1030								
	89																		
	119																		

Table C-5 Torsional stiffness

T_p : Test torque at input speed $n_1 = 1750 \text{ min}^{-1}$

Calculation of the twist angle:

1) At a load torque less than 3% T_p

$$\varphi = \frac{\text{Lost Motion}}{2} \cdot \frac{\text{Load torque}}{0.03 \cdot T_p}$$

2) At a load torque greater than 3% T_p (standard case)

$$\varphi = \frac{\text{Lost Motion}}{2} + \frac{\text{Load torque} - (0.03 \cdot T_p)}{\text{Torsional stiffness}}$$

Note arcmin means “angular minute”.
Table values for stiffness are average values.

Sold & Serviced By:



Toll Free Phone (877) SERV098
www.electromate.com
sales@electromate.com

7.4 No-load running torque NLRT

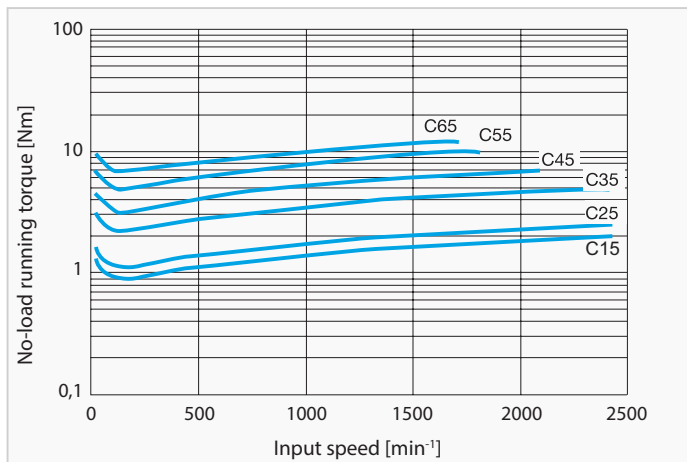

Fig. C-1 Input side no-load running torque

Note

1. Fig. C-1 shows the average no-load running torque after gearbox is run in (not factory-new condition).
2. Table C-6 shows the measuring conditions.

Ring gear housing temperature	approx. 30 °C
Precision during assembly	as per 7.8.1
Lubrication	Standard lubrication

Table C-6 Measurement conditions

7.5 Breakaway torque

Indicates the necessary torque for breakaway of the gearbox on the input or output side, after stop without output side load.

Breakaway torque on output side (BTO)

Note

1. Table C-8 shows the max. breakaway torque on the output side BTO. Fine Cyclo gearboxes are not self-locking. The BTO is defined as the maximum value (factory-new condition), which steadily decreases during the lifetime.
2. Table C-7 shows the measuring conditions.

Precision during assembly	as per 7.8.1
Lubrication	Standard lubrication

Table C-7 Measurement conditions

Size	i	Breakaway torque BTO [Nm]
C15	29	< 70
	59	< 70
	89	< 128
	119	< 128
C25	59	< 200
	89	< 220
	119	< 240
C35	59	< 300
	89	< 415
	119	< 550
C45	59	< 340
	89	< 550
	119	< 715
C55	59	< 600
	89	< 810
	119	< 1000
C65	59	< 700
	89	< 1000
	119	< 2100

Table C-8 Value of the breakaway torque on the output side (BTO)

Breakaway torque on input side (BTI)

Note

1. Table C-9 shows the max. breakaway torque BTI on the input side. BTI is defined as the maximum value (factory-new condition) which steadily decreases during the lifetime.
2. Table C-7 shows the measuring conditions.

Size	Breakaway torque BTI [Nm]
C15	< 2.4
C25	< 3.5
C35	< 4.5
C45	< 6.5
C55	< 9.0
C65	< 11.5

Table C-9 Value of the breakaway torque on the input side (BTI)

7.6 Efficiency

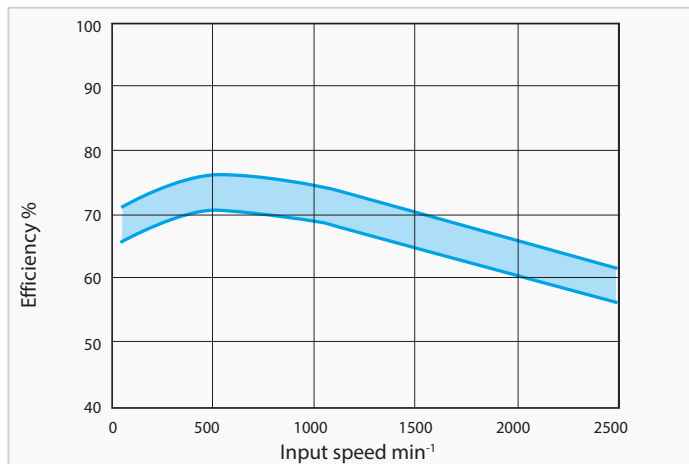

Fig. C-2 a Efficiency curve (size C15-C45)

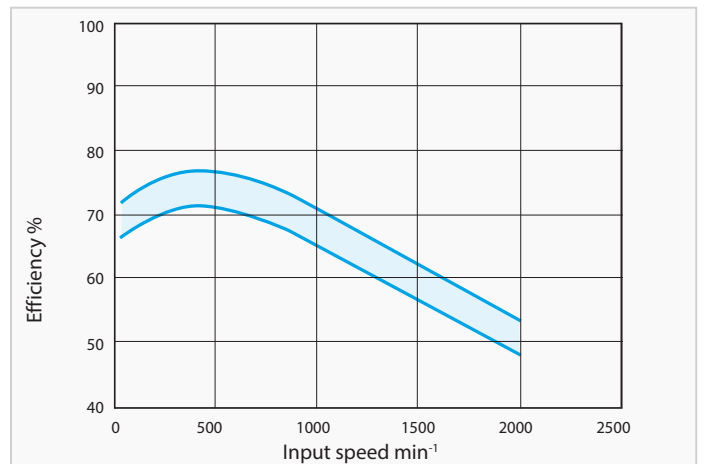

Fig. C-2b Efficiency curve (size C55-C65)

Fig. C-2a and Fig. C-2b show the correlation between efficiency and input speed. Further information see "4 Description of technical specifications for cycloidal gearboxes" on page 22.

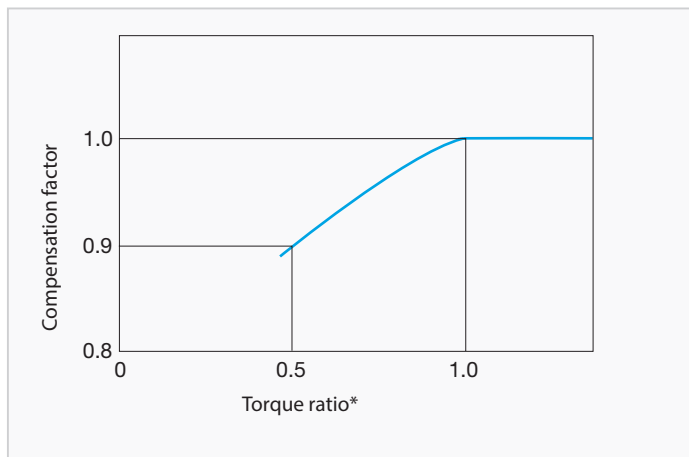

Fig. C-3 Compensation curve for efficiency

$$* \text{Torque ratio} = \frac{\text{Load torque}}{\text{Nominal output torque}}$$

Compensation efficiency = efficiency · compensation factor

- Note**
1. The efficiency changes if the load torque does not match the nominal torque. Check the compensation factor in the diagram Fig. C-3.
 2. When the torque ratio is over 1.0, the compensation factor for efficiency is 1.0 (diagram Fig. C-3).

Sold & Serviced By:



Toll Free Phone (877) SERV098
www.electromate.com
sales@electromate.com

7.7 Bearing loads

7.7.1 Maximum permissible radial and axial load on the input shaft

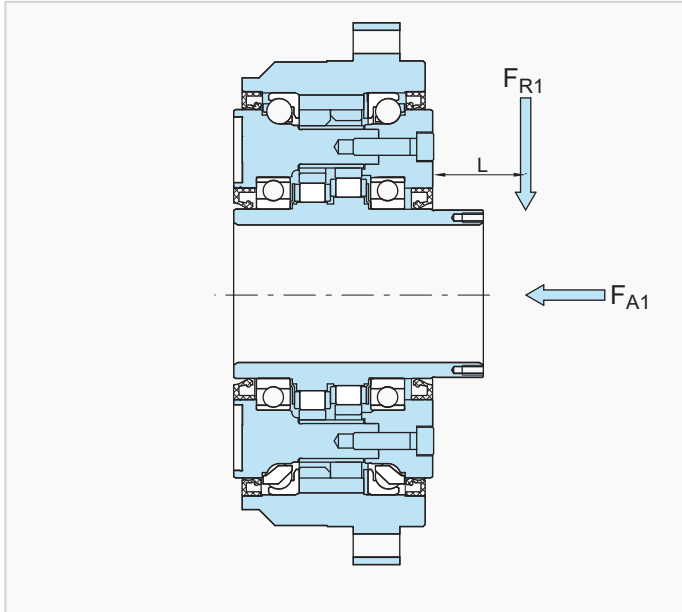

Fig. C-4 Load position on input shaft

L	Load factor input L_{fi}					
	Size					
[mm]	C15	C25	C35	C45	C55	C65
5	0.79	0.8	0.76	0.75	0.73	0.73
10	0.86	0.86	0.81	0.79	0.77	0.77
15	0.93	0.92	0.86	0.83	0.8	0.8
20	1	0.98	0.9	0.87	0.84	0.84
25	1.25	1.14	0.95	0.91	0.88	0.87
30	1.5	1.36	1	0.95	0.91	0.9
35	1.75	1.59	1.17	0.99	0.95	0.94
40	2	1.82	1.33	1.11	0.99	0.97
45	2.25	2.05	1.5	1.25	1.07	1.02
50	2.5	2.27	1.67	1.39	1.19	1.14
60	3	2.73	2	1.67	1.43	1.36
70				1.94	1.67	1.59
80					1.9	1.82

Table C-10 Load factor input L_{fi}
L = distance from input side carrier

If a gear or timing belt pulley is mounted on the input shaft, the values for radial load and axial load should be equal to or less than the permissible values. The following equation is used to check whether the shaft load is permissible:

1. Input radial load F_{R1}

$$F_{R1} = 10^3 \cdot \frac{T_{2V}}{\eta \cdot i \cdot r_0} \leq \frac{F_{R1 \max}}{L_{fi} \cdot C_{fi} \cdot B_{fi}} \quad [\text{N}] \quad (\text{Equation C-1})$$

2. Input side axial load F_{A1}

$$F_{A1} \leq \frac{F_{A1 \max}}{C_{fi} \cdot B_{fi}} \quad [\text{N}] \quad (\text{Equation C-2})$$

3. When radial and axial loads co-exist

$$\left(\frac{F_{R1} \cdot L_{fi}}{F_{R1 \max}} + \frac{F_{A1}}{F_{A1 \max}} \right) \cdot C_{fi} \cdot B_{fi} \leq 1 \quad (\text{Equation C-3})$$

F_{R1} = input side radial load [N]

T_{2V} = reference torque on output shaft [Nm]

r_0 = pitch circle radius of sprocket, pinion, or timing belt pulley [mm]

$F_{R1 \max}$ = maximum permissible input side radial load [N] (Table C-11)

F_{A1} = input side axial load [N]

$F_{A1 \max}$ = maximum permissible input side axial load [N] (Table C-12)

L_{fi} = load factor input (Table C-10)

C_{fi} = correction factor input (Table C-13)

B_{fi} = service factor input (Table C-14)

L = distance of the radial load from the input side carrier (Table C-10)

η = 0.7 (efficiency)

Sold & Serviced By:



Toll Free Phone (877) SERV098

www.electromate.com

sales@electromate.com

Size	Input speed n_{1m} [min ⁻¹]						
	2500	2000	1750	1500	1000	750	600
C15	384	453	491	534	655	748	825
C25	523	563	589	620	709	781	841
C35			687	723	828	911	981
C45			785	826	946	1041	1121
C55				981	1123	1236	1332
C65					1419	1561	1682

Table C-11 Max. permissible input side radial load $F_{R1\ max}$ [N]

Size	Input speed n_{1m} [min ⁻¹]						
	2500	2000	1750	1500	1000	750	600
C15	432	479	509	546	658	751	832
C25	540	589	628	677	824	942	1040
C35		746	795	863	1040	1197	1334
C45			912	981	1197	1373	1530
C55				1481	1785	2050	2276
C65					2570	2953	3286

Table C-12 Max. permissible input side axial load $F_{A1\ max}$ [N]

Calculation of the max. permissible radial load on the input shaft

Calculation of the max. permissible radial load using the following equation when the speed is not shown in the table above.

$$F_{R1\ max} = F_{R1,600} \left(\frac{600}{n_{1m}} \right)^{1/3}$$

$F_{R1\ max}$ = maximum permissible input side radial load at input speed n_{1m}

$F_{R1,600}$ = Radial load on input side at input speed $n_{1m} = 600\ \text{min}^{-1}$

Correction factor input	C_{fi}
Chain	1
Gear or pinion *	1.25
Timing belt	1.25
V-Belt	1.5

Table C-13 Correction factor input C_{fi}

* For helical pinions or bevel gears, please consult Sumitomo Drive Technologies.

Calculation of the max. permissible axial load on the input shaft

Calculation of the max. permissible axial load using the following equation when the speed is not shown in the table above.

$$F_{A1\ max} = F_{A1,600} \left(\frac{600}{n_{1m}} \right)^{0.47}$$

$F_{A1\ max}$ = maximum permissible input side axial load at input speed n_{1m}

$F_{A1,600}$ = Axial load on input side at input speed $n_{1m} = 600\ \text{min}^{-1}$

Service factor input	B_{fi}
Uniform load	1
Light impacts	1.2
Severe impacts	1.6

Table C-14 Service factor input B_{fi}

Sold & Serviced By:



Toll Free Phone (877) SERV098
www.electromate.com
sales@electromate.com

7.7.2 Main bearing

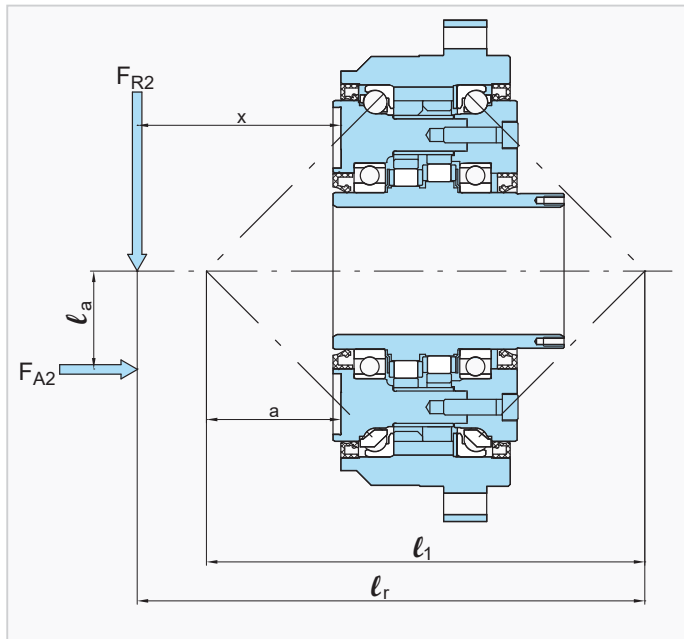

Fig. C-5 Distance between the individual loading points

$$l_r = x - a + l_1 \quad \text{(Equation C-4)}$$

1. Moment stiffness

The moment stiffness is the bending moment at which the output flange is tilted by the tilt angle.

The tilt angle of the input flange is determined as follows:

$$\varphi_1 = \frac{T_k}{\Theta_1} \quad \text{(Equation C-5)}$$

External bending moment T_k

$$T_k = 10^{-3} \cdot (F_{R2} \cdot l_r + F_{A2} \cdot l_a) \quad \text{(Equation C-6)}$$

2. Max. permissible bending moment and max. permissible axial load

Check the external bending moment and the external axial load using equations C-6, C-7, and C-8.

Equivalent bending moment T_{ke}

$$T_{ke} = 10^{-3} \cdot (C_{f2} \cdot B_{f2} \cdot F_{R2} \cdot l_r + C_{f2} \cdot B_{f2} \cdot F_{A2} \cdot l_a) < T_{kmax} \quad \text{(Equation C-7)}$$

Equivalent axial load F_{A2e} at the output shaft

$$F_{A2e} = F_{A2} \cdot C_{f2} \cdot B_{f2} < F_{A2max} \quad \text{(Equation C-8)}$$

Size	Values of internal bearing distance	
	l_1 [mm]	a [mm]
C15	130.6	33.2
C25	162	43.3
C35	196.2	54.9
C45	158.8	30.9
C55	191.8	41.9
C65	211.8	46.4

Table C-15 Bearing spacing dimensions [mm]

Note If: $l_r > 4 \cdot l_1$, please contact Sumitomo Drive Technologies.

- F_{A2} = output side axial load [N]
- F_{A2max} = maximum permissible output side axial load [N]
- F_{A2e} = equivalent output side axial load [N]
- F_{R2} = output side radial load [N]
- C_{f2} = correction factor output (Table C-17)
- B_{f2} = service factor output (Table C-18)
- l_1 = bearing clearance [mm] (Table C-15)
- l_r = calculated dimension for bending moment [mm]
- l_a = distance of axial load [mm]
- x = distance from radial force to flange collar [mm]
- a = correction factor [mm] (Table C-15)
- T_k = external bending moment [Nm]
- T_{kmax} = maximum permissible bending moment [Nm] (Table C-19)
- T_{ke} = equivalent bending moment [Nm]
- φ_1 = tilt angle [arcmin]
- Θ_1 = moment stiffness main bearing [Nm/arcmin] (Table C-16)

Sold & Serviced By:

 Toll Free Phone (877) SERV098
www.electromate.com
sales@electromate.com

Size	Moment stiffness Θ_1
	[Nm/arcmin]
C15	548
C25	1150
C35	2400
C45	2649
C55	3924
C65	5690

Table C-16 Average values for moment stiffness

Size	Max. permissible bending moment	Max. permissible axial load $F_{A2 \max}$
	$T_{k \max}$ [Nm]	[N]
C15	1069	3924
C25	1850	7848
C35	2850	10790
C45	3924	8339
C55	6082	10791
C65	8829	13734

Table C-19 Max. permissible bending moment and max. permissible axial load

Correction factor output	C_{f2}
Chain	1
Gear or pinion	1.25
Timing belt	1.25
V-Belt	1.5

Table C-17 Correction factor output C_{f2}

Service factor output	B_{f2}
Uniform load (no shock)	1
Light impacts	1.2
Severe impacts	1.6

Table C-18 Service factor output B_{f2}

Sold & Serviced By:

 Toll Free Phone (877) SERV098
www.electromate.com
sales@electromate.com

7.8 Assembly specifications and tolerances

7.8.1 Assembly tolerances

Fits for assembly of input and output parts (timing belt, disc, gear, etc.) are shown schematically in the following figure. Use the diameters and tolerances shown in the table below.

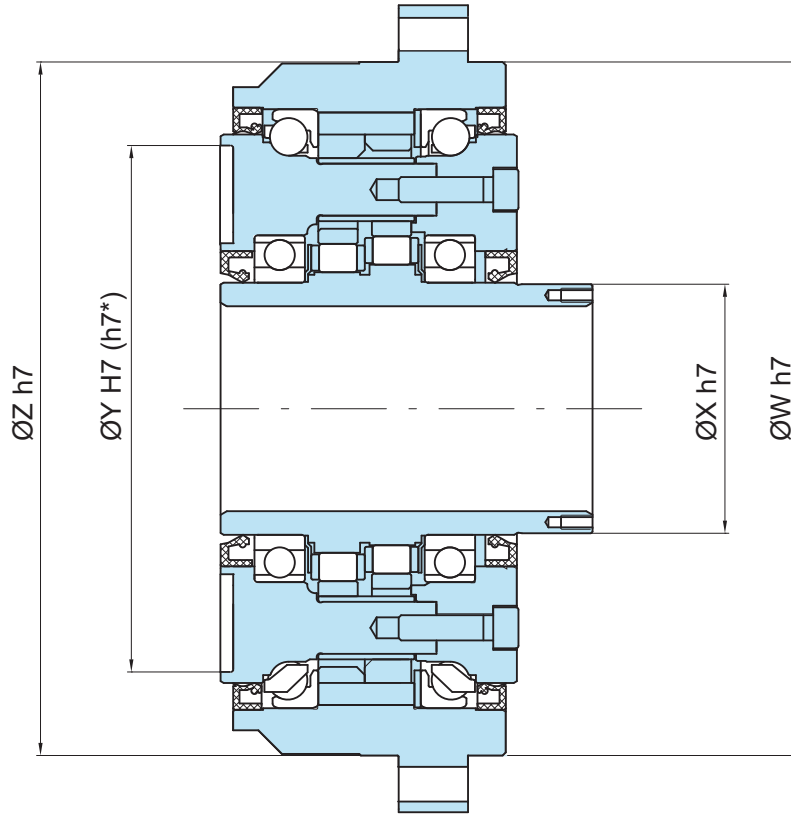

* valid for size C15

Size	ØW	ØX	ØY	ØZ
C15	137	49.5	71 h7	137
C25	185	59	133 H7	185
C35	220	79	167 H7	220
C45	250	94	192 H7	250
C55	284	109	218 H7	284
C65	320	119	245 H7	320

Table C-20 (Dimensions in mm)

Sold & Serviced By:



Toll Free Phone (877) SERV098
www.electromate.com
sales@electromate.com

7.8.2 Assembly procedure

(1)

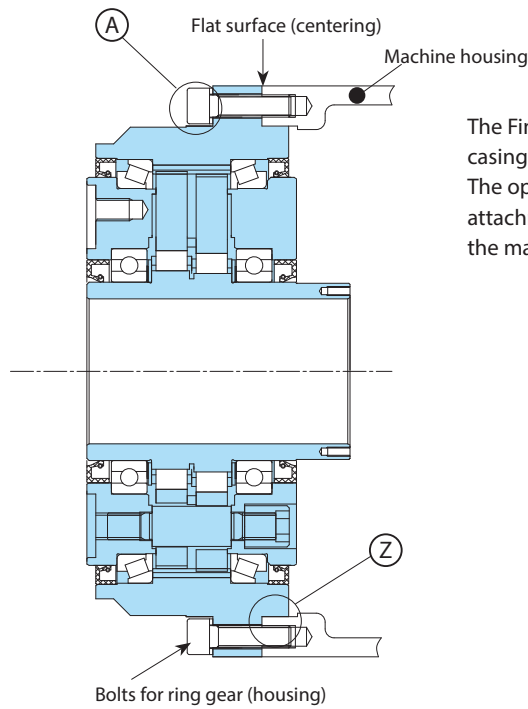

The Fine Cyclo C Series is attached to the machine casing by bolts. (spigot Z)
The opposite side (spigot A) can also be used for attachment to a machine housing when installed into the machine.

(2)

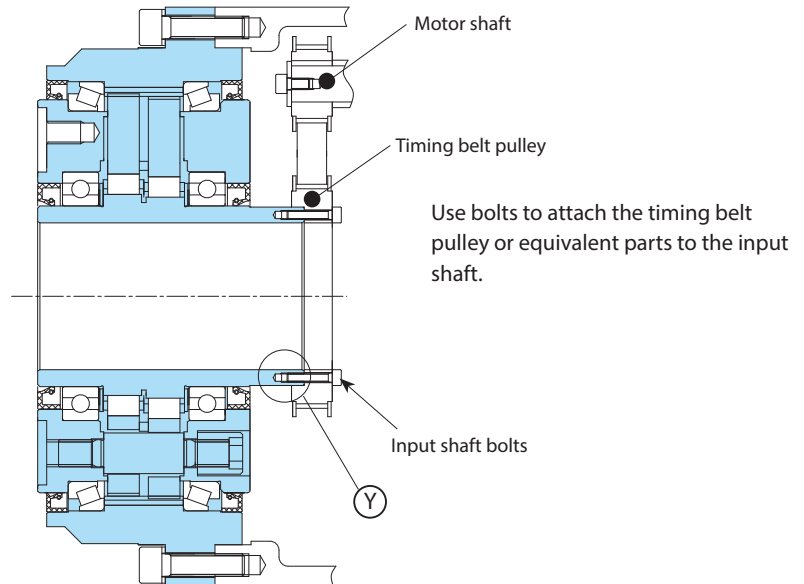

Use bolts to attach the timing belt pulley or equivalent parts to the input shaft.

(3)

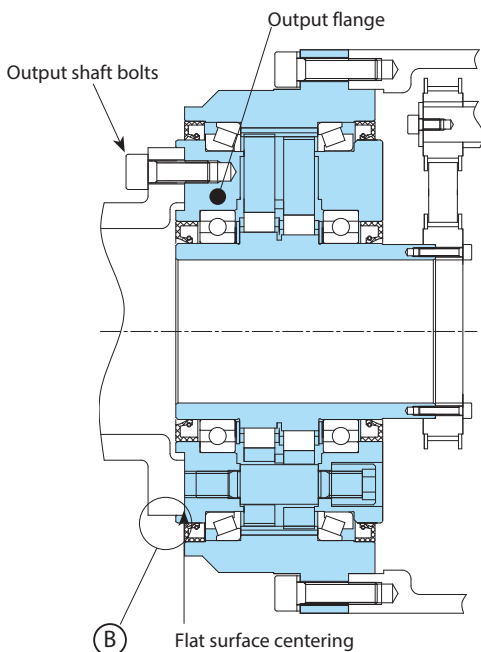

Use bolts to attach output flange of Fine Cyclo to output shaft of machine. (spigot B)

Note!

1. Make sure that you use the correct tightening torque for all fastening bolts when attaching the gearbox (see. Table C-21).
2. Use bolts that are shorter than the depth of the threaded holes in the dimensioned drawings of the output flange.

7.8.3 Tightening torque and maximum permissible transmittable torque for bolts

The permissible transmitted torque for bolts and the number, size, and tightening torque for fastening the output side flange and the ring gear housing are listed in Table C-21. In the event of an Emergency Stop with corresponding load peaks, the output flange and ring gear housing bolts must all be replaced.

Size	Output flange bolts			Bolts for ring gear (housing)		
	Number and size of bolts	Tightening torque [Nm]	Max. permissible transmittable torque for bolts [Nm]	Number and size of bolts	Tightening torque [Nm]	Max. permissible transmittable torque for bolts [Nm]
C15	16 × M6	13.6	1252	12 × M6	13.6	1520
C25	12 × M8	33.4	2080	12 × M8	33.4	3178
C35	12 × M10	65.7	4267	8 × M10	65.7	4670
C45	12 × M12	114	7191	8 × M12	114	7760
C55	12 × M14	181	10919	12 × M12	114	13008
C65	12 × M16	284	16893	16 × M12	114	19404

Size	Eccentric input shaft		
	Number and size of bolts	Tightening torque [Nm]	Max. permissible transmittable torque for bolts [Nm]
C15	6 × M3	1.67	57
C25	6 × M3	1.67	69
C35	6 × M4	3.92	157
C45	6 × M4	3.92	196
C55	8 × M5	8.04	481
C65	12 × M5	8.04	785

Table C-21

- **Bolting:** Use metric hexagon socket head screws (DIN 4762, strength category 10.9).
- **Countermeasure for bolts loosening:** Use adhesives (Loctite 262, etc.) or spring washer (DIN 127A).
- **Use spring washers** (DIN 6796) when connecting the gearbox to the flange side, so that the bolt contact faces do not get damaged.

7.8.4 Lubrication

- The gearboxes of the Fine Cyclo C Series are filled with grease before delivery and are ready to use.
- Reconditioning is recommended after 20,000 operating hours, but at least every 3-5 years.
- The lifetime of the gearbox can be increased by returning it to the factory for overhauling and regreasing.

Specified grease	Manufacturer
Multemp FZ No. 00	Kyodo Yushi Co., Ltd.
Conditions for use: Ambient temperature -10 °C to +40 °C	

Table C-22 Specified grease for the C Series

Size	Quantity of grease [g]
C15	45
C25	75
C35	110
C45	140
C55	200
C65	300

Table C-23 Lubrication

7.9 Dimensioned drawings

F4CF-C15

Mass 6 kg

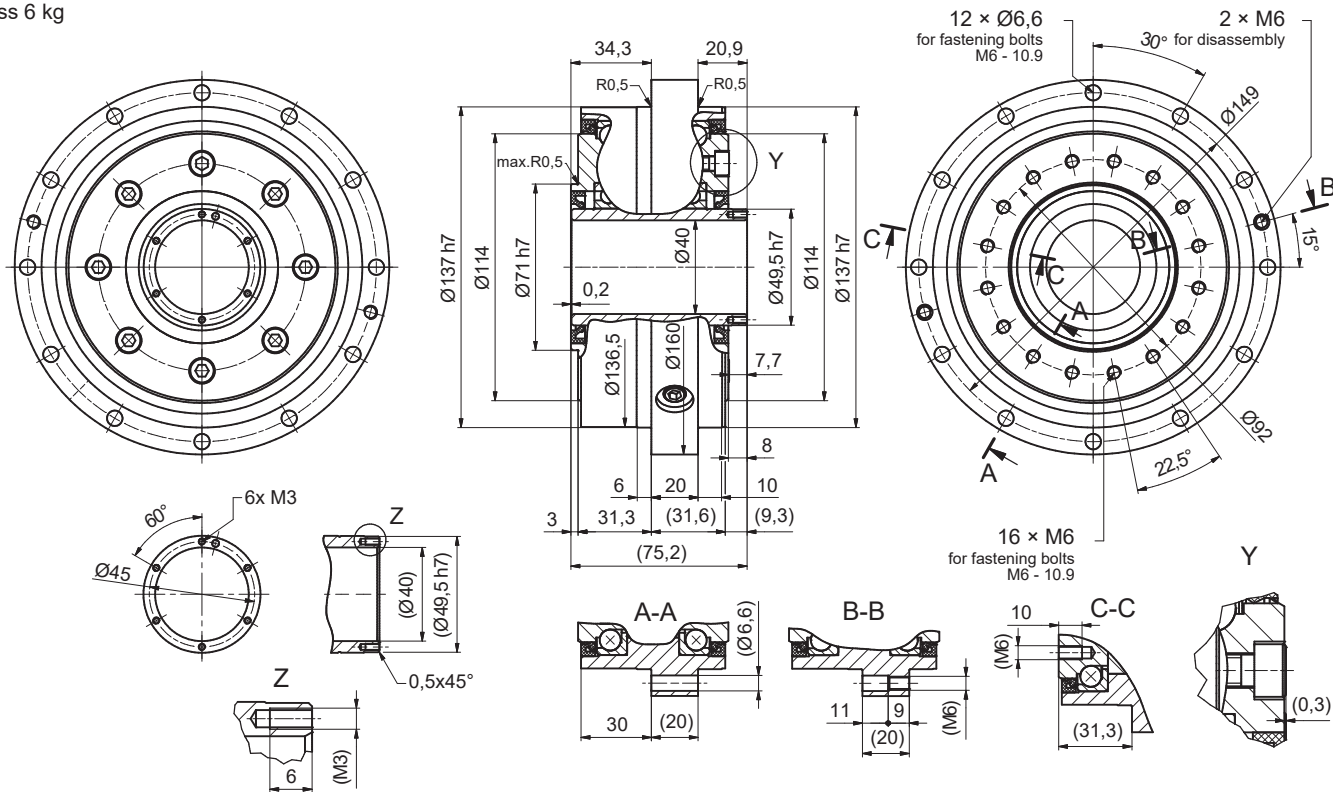

F4C-C25

Mass 12.5 kg

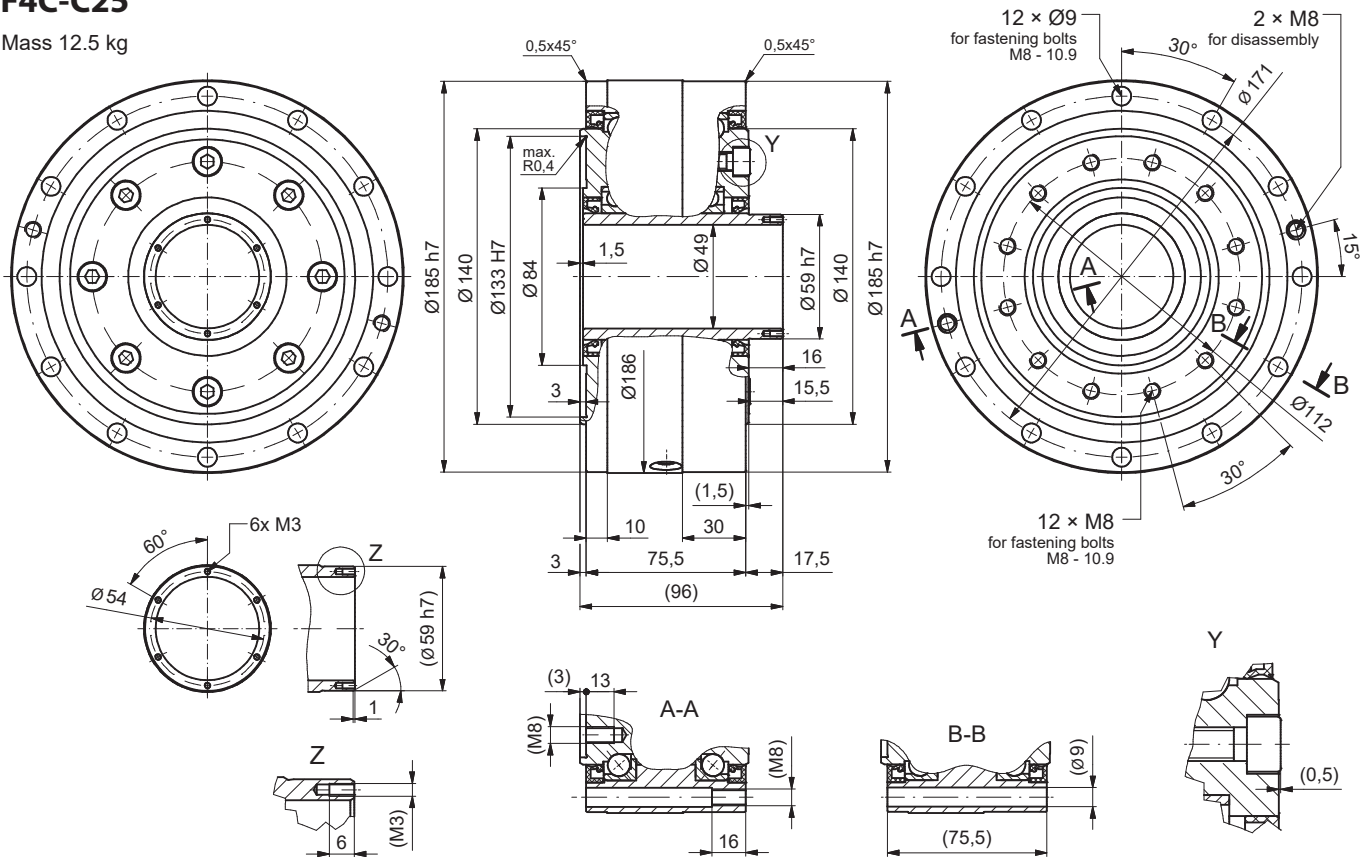

F4CF-C35

Mass 21 kg

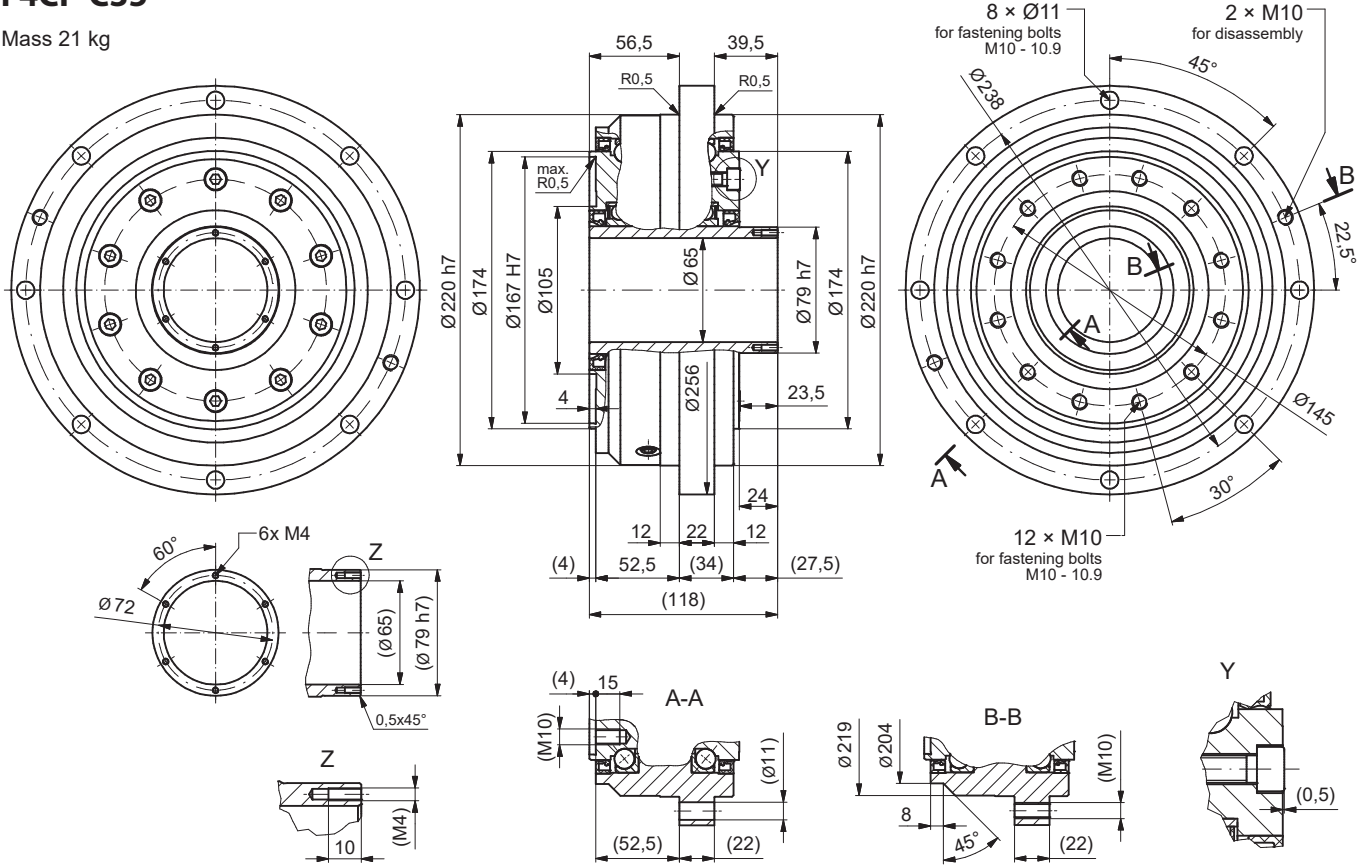

F2CF-C45

Mass 32 kg

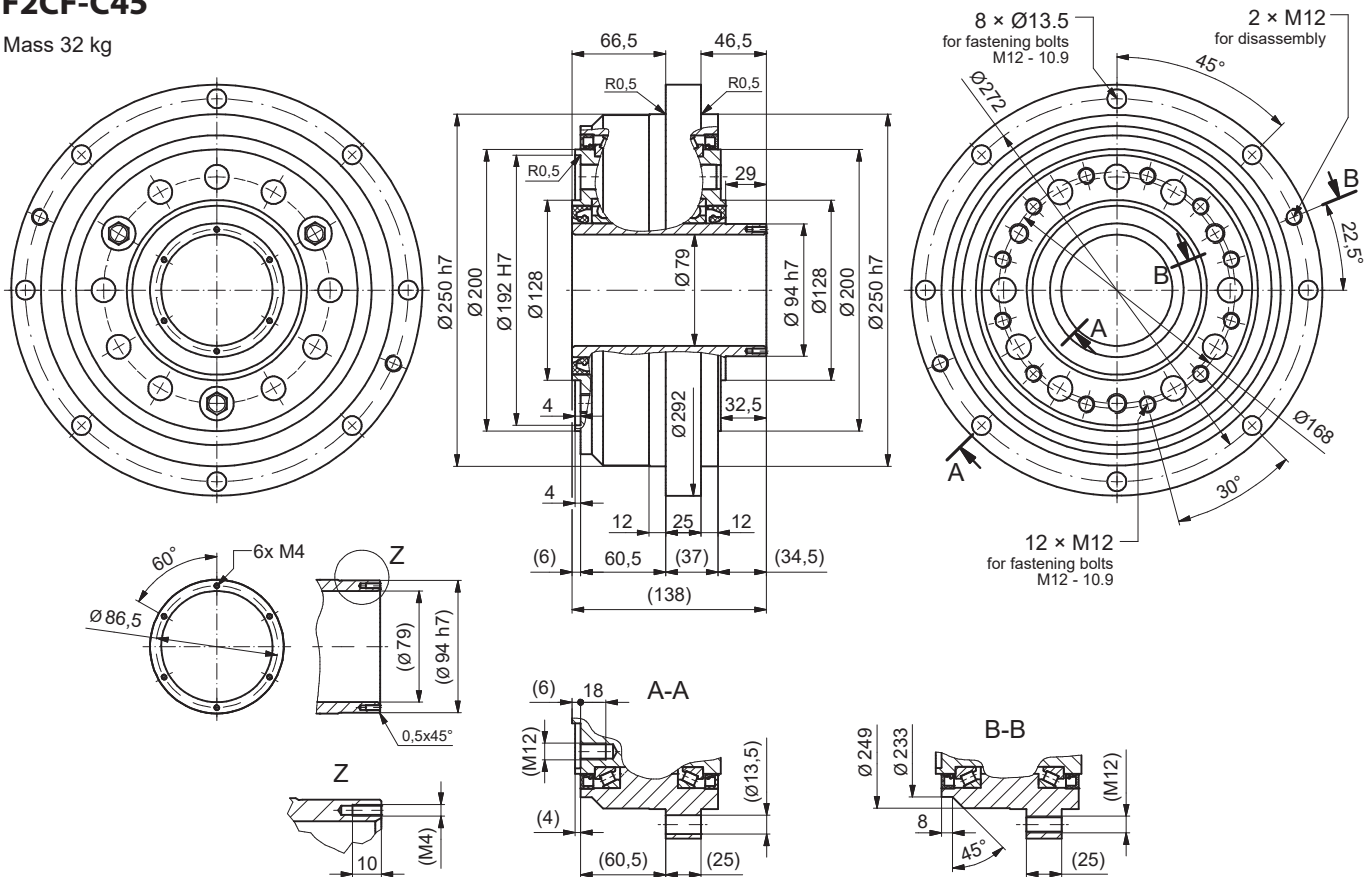

F2CF-C55

Mass 45 kg

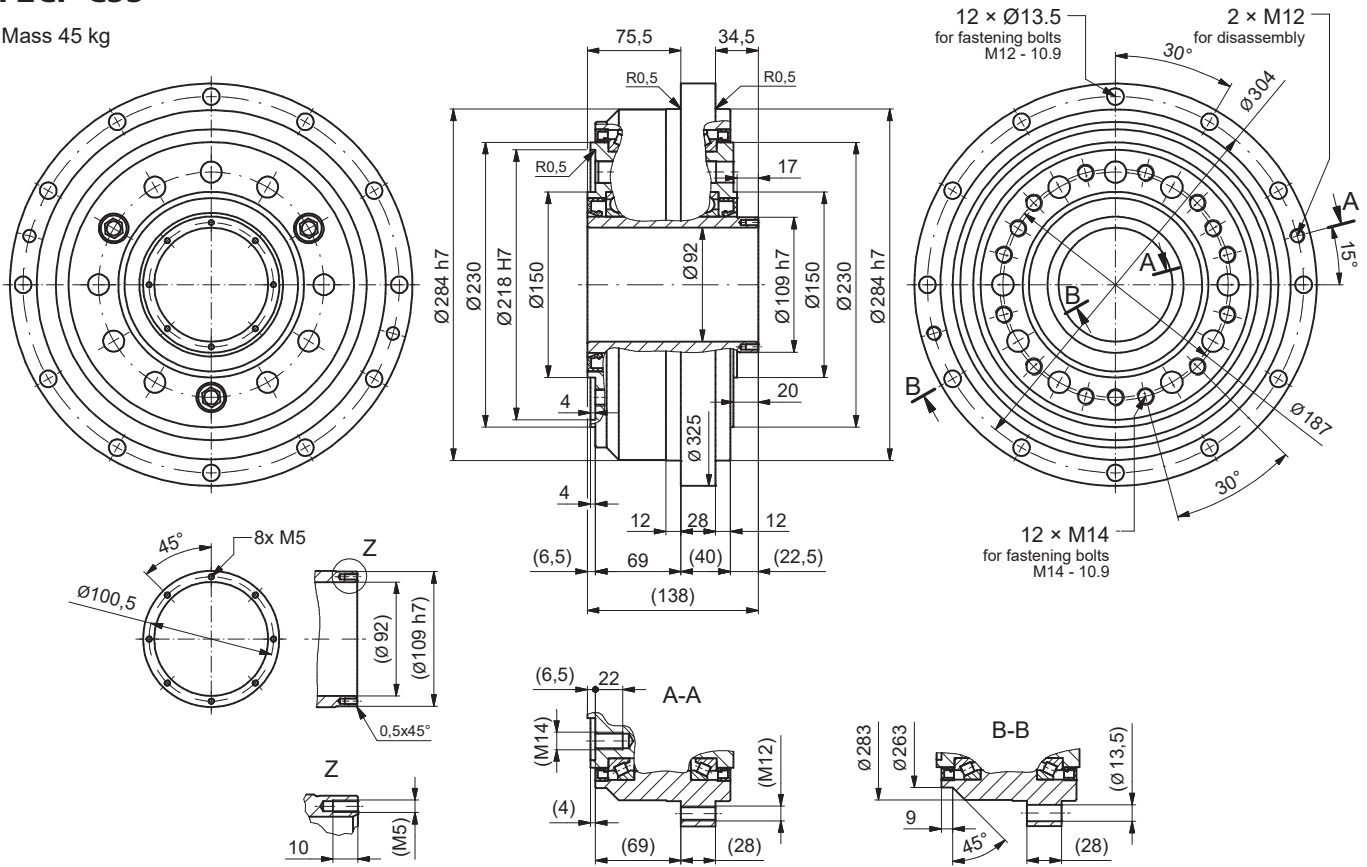

F2CF-C65

Mass 62 kg

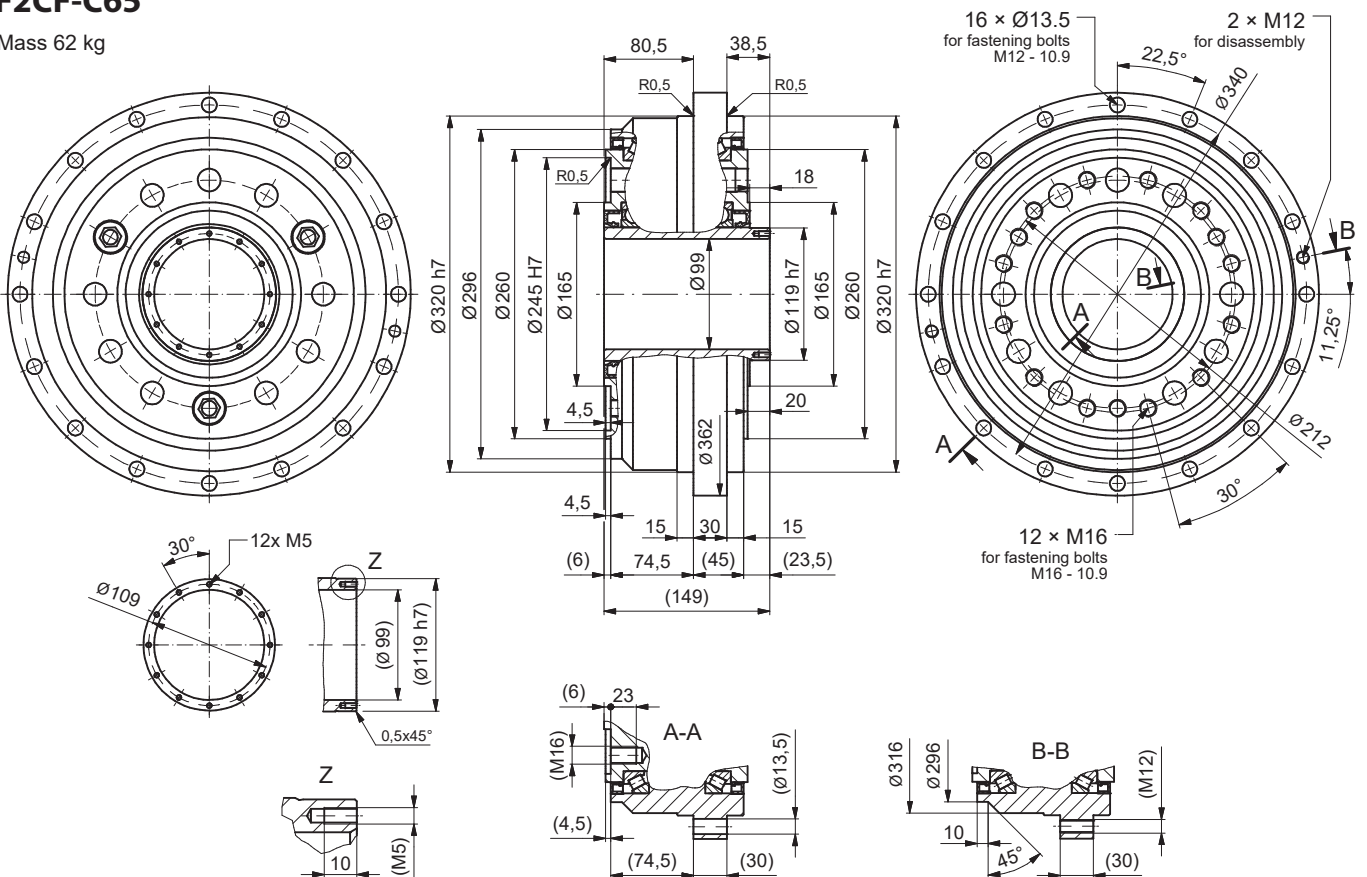

8 UA-Series

F4CF-UA
F2CF-UA

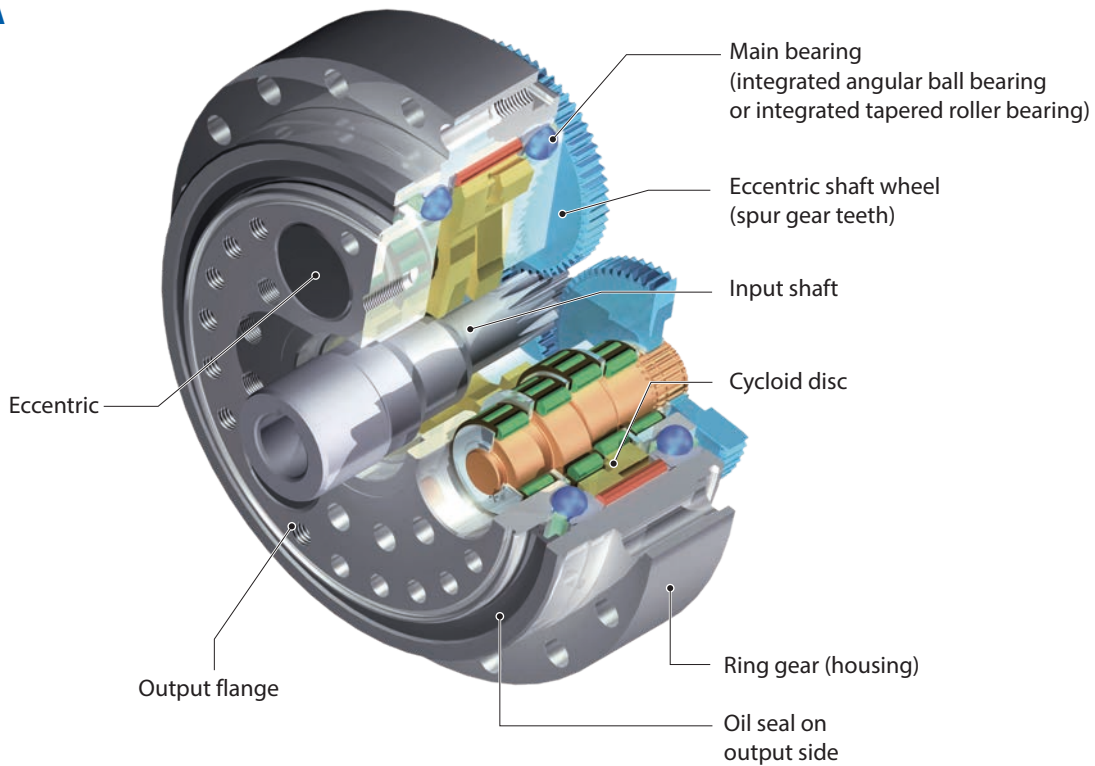

Special feature:

Upstream spur gear stage, gearbox with high positioning and path accuracy, even under changing dynamic conditions

- 7 sizes
- Low mass moments of inertia
- Double-stage ratios 66 to 283
- Nominal output torques up to 6952 Nm
- Acceleration torques up to 12500 Nm
- Input speeds up to 10271 min⁻¹
- Lost motion < 1 arcmin
- Improved moment stiffness
- High efficiency, even at low speeds
- Low vibration

Sold & Serviced By:

 **ELECTROMATE**

Toll Free Phone (877) SERV098

www.electromate.com

sales@electromate.com

8.1 Torques according to output speeds

		Output speed n_{2m} [min ⁻¹]		5			10			15			20		
Model	Size	Reduction ratio i nominal	Reduction ratio i real	Nominal output torque [Nm]	Input speed [min ⁻¹]	Max. permissible input power [kW]	Nominal output torque [Nm]	Input speed [min ⁻¹]	Max. permissible input power [kW]	Nominal output torque [Nm]	Input speed [min ⁻¹]	Max. permissible input power [kW]	Nominal output torque [Nm]	Input speed [min ⁻¹]	Max. permissible input power [kW]
F4CF-	UA15	60	59.5	348	298	0.24	282	595	0.39	250	893	0.52	250	1190	0.70
		84	1603/19	348	422	0.24	282	844	0.39	250	1266	0.52	250	1687	0.70
		91	91	348	455	0.24	282	910	0.39	250	1365	0.52	250	1820	0.70
		127	127	348	635	0.24	282	1270	0.39	250	1905	0.52	250	2540	0.70
		139	1813/13	348	697	0.24	282	1395	0.39	250	2092	0.52	250	2789	0.70
		171	1883/11	348	856	0.24	282	1712	0.39	250	2568	0.52	250	3424	0.70
	UA25	78	77.5	695	388	0.49	565	775	0.79	500	1163	1.05	500	1550	1.40
		88	965/11	695	439	0.49	565	877	0.79	500	1316	1.05	500	1755	1.40
		115	115	695	575	0.49	565	1150	0.79	500	1725	1.05	500	2300	1.40
		124	2105/17	695	619	0.49	565	1238	0.79	500	1857	1.05	500	2476	1.40
		145	145	695	725	0.49	565	1450	0.79	500	2175	1.05	500	2900	1.40
		173	2245/13	695	863	0.49	565	1727	0.79	500	2590	1.05	500	3454	1.40
	UA35	82	82	1251	410	0.87	1016	820	1.42	900	1230	1.88	900	1640	2.51
		87	2003/23	1251	435	0.87	1016	871	1.42	900	1306	1.88	900	1742	2.51
		121	121	1251	605	0.87	1016	1210	1.42	900	1815	1.88	900	2420	2.51
		152	152.2	1251	761	0.87	1016	1522	1.42	900	2283	1.88	900	3044	2.51
		166	1159/7	1251	828	0.87	1016	1656	1.42	900	2484	1.88	900	3311	2.51
		82	82	1835	410	1.28	1491	820	2.08	1320	1230	2.76	1320	1640	3.69
	UA45	99	691/7	1835	494	1.28	1491	987	2.08	1320	1481	2.76	1320	1974	3.69
		121	121	1835	605	1.28	1491	1210	2.08	1320	1815	2.76	1320	2420	3.69
		130	2213/17	1835	651	1.28	1491	1302	2.08	1320	1953	2.76	1321	2604	3.69
		152	152.2	1835	761	1.28	1491	1522	2.08	1320	2283	2.76	1320	3044	3.69
		166	1159/7	1835	828	1.28	1491	1656	2.08	1320	2484	2.76	1320	3311	3.69
		81	81	2781	405	1.94	2259	810	3.15	2000	1215	4.19	1321	1620	3.69
	UA55	97	97	2781	485	1.94	2259	970	3.15	2000	1455	4.19	1322	1940	3.69
		126	125.8	2781	629	1.94	2259	1258	3.15	2000	1887	4.19	1323	2516	3.69
		145	145	2781	725	1.94	2259	1450	3.15	2000	2175	4.19	1324	2900	3.70
		169	169	2781	845	1.94	2259	1690	3.15	2000	2535	4.19	1325	3380	3.70
		241	241	2781	1205	1.94	2259	2410	3.15	2000	3615	4.19	1326	4820	3.70
		89	88.75	4769	444	3.33	3874	888	5.41	3430	1331	7.18	3430	1775	9.58
F2CF-	UA65	121	1579/13	4769	607	3.33	3874	1215	5.41	3430	1822	7.18	3430	2429	9.58
		136	136	4769	680	3.33	3874	1360	5.41	3430	2040	7.18	3430	2720	9.58
		144	3317/23	4769	721	3.33	3874	1442	5.41	3430	2163	7.18	3430	2884	9.58
		163	163	4769	815	3.33	3874	1630	5.41	3430	2445	7.18	3430	3260	9.58
		171	2227/13	4769	857	3.33	3874	1713	5.41	3430	2570	7.18	3430	3426	9.58
		199	199	4769	995	3.33	3874	1990	5.41	3430	2985	7.18	3430	3980	9.58
		249	249.4	4769	1247	3.33	3874	2494	5.41	3430	3741	7.18	3430	4988	9.58
		93	92.8	6952	464	4.85	5647	928	7.88	5000	1392	10.47	5000	1856	13.96
	UA80	103	1445/14	6952	516	4.85	5647	1032	7.88	5000	1548	10.47	5000	2064	13.96
		122	121.96	6952	610	4.85	5647	1220	7.88	5000	1829	10.47	5000	2439	13.96
		155	1087/7	6952	776	4.85	5647	1553	7.88	5000	2329	10.47	5000	3106	13.96
		166	165.7	6952	829	4.85	5647	1657	7.88	5000	2486	10.47	5000	3314	13.96
		190	190	6952	950	4.85	5647	1900	7.88	5000	2850	10.47	5000	3800	13.96
		239	1193/5	6952	1193	4.85	5647	2386	7.88	5000	3579	10.47	5000	4772	13.96
		283	3685/13	6952	1417	4.85	5647	2835	7.88	5000	4252	10.47	5000	5669	13.96

Table UA-1 Rating values (reference value output speed n_{2m})

25			30			40			50			60			Max. permissible output speed $n_{2,max}$ short term [min ⁻¹]	Moment of inertia j related to the input shaft [$\times 10^{-4}$ kgm ²]	Mass [kg]		
Nominal output torque [Nm]	Input speed [min ⁻¹]	Max. permissible input power [kW]	Nominal output torque [Nm]	Input speed [min ⁻¹]	Max. permissible input power [kW]	Nominal output torque [Nm]	Input speed [min ⁻¹]	Max. permissible input power [kW]	Nominal output torque [Nm]	Input speed [min ⁻¹]	Max. permissible input power [kW]	Nominal output torque [Nm]	Input speed [min ⁻¹]	Max. permissible input power [kW]					
250	1488	0.87	250	1785	1.05	250	2380	1.40	250	2975	1.75	250	3570	2.09	60	CF	4		
250	2109	0.87	250	2531	1.05	250	3375	1.40	250	4218	1.75	250	5062	2.09		CF			
250	2275	0.87	250	2730	1.05	250	3640	1.40	250	4550	1.75	250	5460	2.09		CF			
250	3175	0.87	250	3810	1.05	250	5080	1.40	250	6350	1.75	250	7620	2.09		CF			
250	3487	0.87	250	4184	1.05	250	5578	1.40	250	6973	1.75	250	8368	2.09		CF			
250	4280	0.87	250	5135	1.05	250	6847	1.40	250	8559	1.75	250	10271	2.09		CF			
500	1938	1.75	500	2325	2.09	500	3100	2.79	500	3875	3.49				50	CF	6		
500	2193	1.75	500	2632	2.09	500	3509	2.79	500	4386	3.49					CF			
500	2875	1.75	500	3450	2.09	500	4600	2.79	500	5750	3.49					CF			
500	3096	1.75	500	3715	2.09	500	4953	2.79	500	6191	3.49					CF			
500	3625	1.75	500	4350	2.09	500	5800	2.79	500	7250	3.49					CF			
500	4317	1.75	500	5181	2.09	500	6908	2.79	500	8635	3.49					CF			
900	2050	3.14	900	2460	3.77	900	3280	5.03							40	CF	11		
900	2177	3.14	900	2613	3.77	900	3483	5.03								CF			
900	3025	3.14	900	3630	3.77	900	4840	5.03								CF			
900	3805	3.14	900	4566	3.77	900	6088	5.03								CF			
900	4139	3.14	900	4967	3.77	900	6623	5.03								CF			
1320	2050	4.61	1320	2460	5.53											30		CF	17
1320	2468	4.61	1320	2961	5.53										CF				
1320	3025	4.61	1320	3630	5.53										CF				
1321	3254	4.61	1321	3905	5.53										CF				
1320	3805	4.61	1320	4566	5.53										CF				
1320	4139	4.61	1320	4967	5.53										CF				
1321	2025	4.61	1321	2430	5.53										30	CF	22		
1322	2425	4.61	1322	2910	5.54											CF			
1323	3145	4.62	1323	3774	5.54											CF			
1324	3625	4.62	1324	4350	5.55											CF			
1325	4225	4.63	1325	5070	5.55											CF			
1326	6025	4.63	1326	7230	5.55											CF			
3430	2219	11.97	3430	2663	14.37										30	CF	38		
3430	3037	11.97	3430	3644	14.37											CF			
3430	3400	11.97	3430	4080	14.37											CF			
3430	3605	11.97	3430	4327	14.37											CF			
3430	4075	11.97	3430	4890	14.37											CF			
3430	4283	11.97	3430	5139	14.37											CF			
3430	4975	11.97	3430	5970	14.37											CF			
3430	6235	11.97	3430	7482	14.37											CF			
5000	2320	17.45														25		CF	56
5000	2580	17.45																CF	
5000	3049	17.45													CF				
5000	3882	17.45													CF				
5000	4143	17.45													CF				
5000	4750	17.45													CF				
5000	5965	17.45													CF				
5001	7087	17.46													CF				

Size	Max. acceleration and deceleration torque T_{2A}	Peak torque for Emergency Stop T_{2max}
	[Nm]	[Nm]
UA15	625	1250
UA25	1250	2500
UA35	2250	4500
UA45	3300	6600
UA55	5000	10000
UA65	8575	17150
UA80	12500	25000

Table UA-2 Maximum acceleration and peak torque

Sold & Serviced By:



Toll Free Phone (877) SERV098
www.electromate.com
sales@electromate.com

1. T_{2N} = nominal output torque
 Nominal output torque corresponds to the max. permissible average load torque at all output speeds.
 The nominal output torque for speeds less than 5 min^{-1} is equal to the value at 5 min^{-1} .
 The value for the maximum permissible input power is calculated from the nominal output torque at 50% ED.
 This value takes the efficiency of Fine Cyclo into consideration.
2. $n_{2\text{max}}$ = maximum permissible input speed
 Gearbox can be used in the maximum input speed range specified in the table.
3. T_{2A} = max. Acceleration and braking torque (for fatigue strength at $2 \cdot 10^7$ load cycles)
 Permissible peak torque for normal start and stop procedures.
4. $T_{2\text{max}}$ = max. permissible torque for Emergency Stop situations or in the event of heavy shocks (limited by the mechanical strength).
 (permissible 1000 x over the entire lifetime)
5. The rated torque T_{2N} is calculated using the following equation when the speed is not shown in the table above:

$$T_{2N} = T_{2N, 15} \left(\frac{15}{n_{2m}} \right)^{0.3}$$

T_{2N} : Rated torque at output speed n_{2m}
 $T_{2N, 15}$: Rated torque at output speed n_{2m} is 15 min^{-1}

Sold & Serviced By:



Toll Free Phone (877) SERV098
www.electromate.com
sales@electromate.com

8.2 Torques according to input speeds

Input speed n_{1m} [min ⁻¹]				5000			4000			3000			2500			2000		
Model	Size	Reduction ratio i nominal	Reduction ratio i real	Nominal output torque [Nm]	Output speed [min ⁻¹]	Max. permissible input power [kW]	Nominal output torque [Nm]	Output speed [min ⁻¹]	Max. permissible input power [kW]	Nominal output torque [Nm]	Output speed [min ⁻¹]	Max. permissible input power [kW]	Nominal output torque [Nm]	Output speed [min ⁻¹]	Max. permissible input power [kW]	Nominal output torque [Nm]	Output speed [min ⁻¹]	Max. permissible input power [kW]
84	1603/19					47	-	193	36	0.96	204	30	0.84	218	24	0.72		
91	91	169	55	1.30	181	44	1.11	197	33	0.91	208	27	0.80	223	22	0.68		
127	127	187	39	1.03	200	31	0.88	218	24	0.72	230	20	0.63	246	16	0.54		
139	1813/13	192	36	0.96	206	29	0.82	224	22	0.67	237	18	0.59	253	14	0.51		
171	1883/11	205	29	0.83	219	23	0.71	239	18	0.58	252	15	0.51	269	12	0.44		
UA25	78	77.5							376	39	2.03	397	32	1.79	425	26	1.53	
	88	965/11				358	46	2.28	390	34	1.86	412	28	1.64	441	23	1.40	
	115	115	363	43	2.21	388	35	1.89	424	26	1.54	447	22	1.36	478	17	1.16	
	124	2105/17	371	40	2.09	397	32	1.79	433	24	1.46	457	20	1.29	489	16	1.10	
	145	145	390	34	1.88	416	28	1.60	454	21	1.31	480	17	1.15	513	14	0.99	
	173	2245/13	410	29	1.66	439	23	1.42	478	17	1.16	505	14	1.02	540	12	0.87	
UA35	82	82							689	37	3.52	727	30	3.10	778	24	2.65	
	87	2003/23							701	34	3.37	741	29	2.97	792	23	2.54	
	121	121				710	33	3.28	774	25	2.68	818	21	2.36	874	17	2.02	
	152	152.2	711	33	3.26	761	26	2.79	829	20	2.28	876	16	2.01	936	13	1.72	
	166	1159/7	730	30	3.08	780	24	2.63	850	18	2.15	898	15	1.89	960	12	1.62	
UA45	82	82										1067	30	4.54	1141	24	3.89	
	99	691/7							1068	30	4.53	1128	25	3.99	1206	20	3.41	
	121	121							1135	25	3.93	1199	21	3.46	1282	17	2.96	
	130	2213/17							1160	23	3.73	1226	19	3.29	1311	15	2.81	
	152	152.2				1116	26	4.09	1216	20	3.35	1285	16	2.95	1373	13	2.52	
	166	1159/7	1070	30	4.51	1144	24	3.86	1247	18	3.16	1317	15	2.78	1409	12	2.38	
UA55	81	81													1722	25	5.94	
	97	97										1700	26	6.12	1818	21	5.23	
	126	125.8				1596	32	7.09	1740	24	5.79	1838	20	5.10	1965	16	4.36	
	145	145				1666	28	6.42	1816	21	5.25	1918	17	4.62	2051	14	3.95	
	169	169				1744	24	5.76	1901	18	4.71	2008	15	4.15	2147	12	3.55	
	241	241				1940	17	4.50	2115	12	3.68	2234	10	3.24	2389	8	2.77	
F2CF-	UA65	89	88.75	2306	56	18.14							2839	28	11.17	3036	23	9.55
		121	1579/13							2953	25	10.19	3119	21	8.96	3335	16	7.67
		136	136				2803	29	11.51	3055	22	9.41	3227	18	8.28	3450	15	7.08
		144	3317/23				2852	28	11.05	3109	21	9.03	3284	17	7.95	3512	14	6.80
		163	163	2767	31	11.85	2959	25	10.14	3226	18	8.29	3407	15	7.30	3643	12	6.24
		171	2227/13	2809	29	11.45	3004	23	9.79	3274	18	8.01	3458	15	7.05	3698	12	6.03
		199	199	2938	25	10.31	3142	20	8.82	3425	15	7.21	3617	13	6.35	3868	10	5.43
		249	249.4	3144	20	8.80	3362	16	7.53	3665	12	6.16	3871	10	5.42	4139	8	4.63
	UA80	93	92.8													4485	22	13.50
		103	1445/14										4330	24	14.65	4630	19	12.53
		122	121.96							4310	25	14.80	4553	20	13.03	4868	16	11.15
		155	1087/7							4634	19	12.50	4895	16	11.00	5234	13	9.41
		166	165.7				4335	24	14.61	4726	18	11.95	4991	15	10.51	5337	12	8.99
		190	190				4517	21	13.28	4924	16	10.85	5200	13	9.55	5561	11	8.17
239	1193/5	4523	21	13.23	4836	17	11.32	5272	13	9.26	5568	10	8.15	5954	8	6.97		
283	3685/13	4763	18	11.73	5092	14	10.03	5551	11	8.20	5864	9	7.22	6270	7	6.18		

Table UA-3 Rating values (reference value input speed n_{2m})

1750			1500			1000			750			600			Max. permissible output speed $n_{2, \max}$ short term [min ⁻¹]	Moment of inertia J related to the input shaft [$\times 10^{-4}$ kgm ²]	Mass [kg]
Nominal output torque [Nm]	Output speed [min ⁻¹]	Max. permissible input power [kW]	Nominal output torque [Nm]	Output speed [min ⁻¹]	Max. permissible input power [kW]	Nominal output torque [Nm]	Output speed [min ⁻¹]	Max. permissible input power [kW]	Nominal output torque [Nm]	Output speed [min ⁻¹]	Max. permissible input power [kW]	Nominal output torque [Nm]	Output speed [min ⁻¹]	Max. permissible input power [kW]			
204	29	0.84	214	25	0.75	242	17	0.57	263	13	0.46	282	10	0.40	60	CF	4
227	21	0.66	238	18	0.59	268	12	0.44	292	9	0.36	313	7	0.31			
232	19	0.62	243	16	0.56	274	11	0.42	299	8	0.34	320	7	0.29			
256	14	0.49	269	12	0.44	303	8	0.33	331	6	0.27	348	5	0.23			
264	13	0.46	276	11	0.41	312	7	0.31	340	5	0.26	348	4	0.21			
280	10	0.40	294	9	0.36	332	6	0.27	348	4	0.21	348	4	0.17			
442	23	1.39	463	19	1.25	523	13	0.94	570	10	0.77	610	8	0.66	50	CF	6
459	20	1.28	481	17	1.15	543	11	0.86	592	9	0.71	633	7	0.60			
498	15	1.06	521	13	0.95	589	9	0.71	642	7	0.58	686	5	0.50			
509	14	1.00	533	12	0.90	602	8	0.68	656	6	0.56	695	5	0.47			
534	12	0.90	559	10	0.81	631	7	0.61	688	5	0.50	695	4	0.40			
562	10	0.80	589	9	0.71	665	6	0.54	695	4	0.42	695	3	0.34			
810	21	2.41	848	18	2.17	958	12	1.63	1044	9	1.33	1116	7	1.14	40	CF	11
824	20	2.31	863	17	2.08	975	11	1.56	1063	9	1.28	1137	7	1.09			
910	14	1.84	953	12	1.65	1076	8	1.24	1173	6	1.02	1251	5	0.87			
975	11	1.56	1021	10	1.40	1153	7	1.06	1251	5	0.86	1251	4	0.69			
1000	11	1.48	1047	9	1.32	1182	6	1.00	1251	5	0.79	1251	4	0.63			
1188	21	3.54	1244	18	3.18	1405	12	2.39	1531	9	1.96	1637	7	1.67			
1255	18	3.11	1315	15	2.79	1485	10	2.10	1619	8	1.72	1731	6	1.47	30	CF	17
1335	14	2.69	1398	12	2.42	1578	8	1.82	1721	6	1.49	1835	5	1.27			
1364	13	2.56	1429	12	2.30	1613	8	1.73	1759	6	1.41	1835	5	1.18			
1430	11	2.30	1497	10	2.06	1691	7	1.55	1835	5	1.26	1835	4	1.01			
1466	11	2.16	1536	9	1.94	1734	6	1.46	1835	5	1.16	1835	4	0.93			
1793	22	5.41	1877	19	4.85	2120	12	3.65	2311	9	2.99	2471	7	2.56			
1892	18	4.77	1982	15	4.28	2238	10	3.22	2440	8	2.63	2609	6	2.25	30	CF	22
2046	14	3.97	2143	12	3.57	2420	8	2.69	2638	6	2.20	2781	5	1.85			
2135	12	3.60	2236	10	3.23	2525	7	2.43	2753	5	1.99	2781	4	1.61			
2235	10	3.23	2341	9	2.90	2644	6	2.18	2781	4	1.72	2781	4	1.38			
2486	7	2.52	2604	6	2.26	2781	4	1.61	2781	3	1.21	2781	2	0.97			
3160	20	8.70	3309	17	7.81	3737	11	5.88	4074	8	4.81	4356	7	4.11			
3472	14	6.98	3636	12	6.27	4106	8	4.72	4476	6	3.86	4769	5	3.29	30	CF	38
3591	13	6.45	3761	11	5.79	4248	7	4.36	4631	6	3.57	4769	4	2.94			
3655	12	6.19	3828	10	5.56	4323	7	4.19	4713	5	3.42	4769	4	2.77			
3792	11	5.68	3971	9	5.10	4485	6	3.84	4769	5	3.06	4769	4	2.45			
3849	10	5.49	4031	9	4.93	4553	6	3.71	4769	4	2.92	4769	4	2.33			
4026	9	4.94	4216	8	4.44	4762	5	3.34	4769	4	2.51	4769	3	2.01			
4308	7	4.22	4512	6	3.79	4769	4	2.67	4769	3	2.00	4769	2	1.60	25	CF	56
4668	19	12.29	4889	16	11.03	5522	11	8.31	6019	8	6.79	6436	6	5.81			
4820	17	11.41	5048	15	10.24	5701	10	7.71	6214	7	6.31	6645	6	5.39			
5067	14	10.15	5307	12	9.11	5993	8	6.86	6533	6	5.61	6952	5	4.78			
5448	11	8.57	5706	10	7.70	6444	6	5.79	6952	5	4.69	6952	4	3.75			
5555	11	8.19	5818	9	7.35	6570	6	5.54	6952	5	4.39	6952	4	3.51			
5788	9	7.44	6062	8	6.68	6846	5	5.03	6952	4	3.83	6952	3	3.07	CF		
6197	7	6.35	6490	6	5.70	6952	4	4.07	6952	3	3.05	6952	3	2.44			
6526	6	5.63	6835	5	5.05	6952	4	3.42	6952	3	2.57	6952	2	2.05	CF		

Size	Max. acceleration and deceleration torque T_{2A}	Peak torque for Emergency Stop T_{2max}
	[Nm]	[Nm]
UA15	625	1250
UA25	1250	2500
UA35	2250	4500
UA45	3300	6600
UA55	5000	10000
UA65	8575	17150
UA80	12500	25000

Table UA-4 Maximum acceleration and peak torque

Sold & Serviced By:



Toll Free Phone (877) SERV098

www.electromate.com

sales@electromate.com

1. T_{2N} = nominal output torque
Nominal output torque corresponds to the max. permissible average load torque at all input speeds.
The nominal output torque for speeds n_2 less than 5 min^{-1} is equal to the value at 5 min^{-1} .
The value for the maximum permissible input power is calculated from the nominal output torque at 50% ED.
This value takes the efficiency of Fine Cyclo into consideration.
2. $n_{2\text{max}}$ = maximum permissible input speed
Gearbox can be used in the maximum input speed range specified in the table.
3. T_{2A} = max. Acceleration and braking torque (for fatigue strength at $2 \cdot 10^7$ load cycles)
Permissible peak torque for normal start and stop procedures.
4. $T_{2\text{max}}$ = max. permissible torque for Emergency Stop situations or in the event of heavy shocks (limited by the mechanical strength).
(permissible 1000 x over the entire lifetime)
5. The rated torque T_{2N} is calculated using the following equation when the speed is not shown in the table above:

$$T_{2N} = T_{2N, 15} \left(\frac{15}{n_{2m}} \right)^{0.3}$$

T_{2N} : Rated torque at output speed n_{2m}
 $T_{2N, 15}$: Rated torque at output speed n_{2m} is 15 min^{-1}

Sold & Serviced By:



Toll Free Phone (877) SERV098
www.electromate.com
sales@electromate.com

8.3 Stiffness and Lost Motion

Size	i	Test torque T_p [Nm]	Lost Motion		Torsional stiffness 50% - 100% T_p [Nm/arcmin]
			Lost Motion [arcmin]	Domain of definition [Nm]	
UA15	60 / 84 / 91 / 127 / 139 / 171	250	< 0.75	±7.5	63
UA25	78 / 88 / 115 / 124 / 145 / 173	500	< 0.5	±15	112
UA35	82 / 87 / 121 / 152 / 166	900		±27	196
UA45	82 / 99 / 121 / 130 / 152 / 166	1320		±40	343
UA55	81 / 97 / 126 / 145 / 169 / 241	2000		±60	530
UA65	89 / 121 / 136 / 144 / 163 / 171 / 199 / 249	3430		±103	933
UA80	93 / 103 / 122 / 155 / 166 / 190 / 239 / 283	5000		±150	1300

Table UA-5 Torsional stiffness

T_p : Test torque at input speed $n_1 = 1500 \text{ min}^{-1}$

Note arcmin means “angular minute”.
Table values for stiffness are average values.

Calculation of the twist angle:

1) At a load torque less than 3% T_p

$$\varphi = \frac{\text{Lost Motion}}{2} \cdot \frac{\text{Load torque}}{0.03 \cdot T_p}$$

2) At a load torque greater than 3% T_p (standard case)

$$\varphi = \frac{\text{Lost Motion}}{2} + \frac{\text{Load torque} - (0.03 \cdot T_p)}{\text{Torsional stiffness}}$$

8.4 No-load running torque NLRT

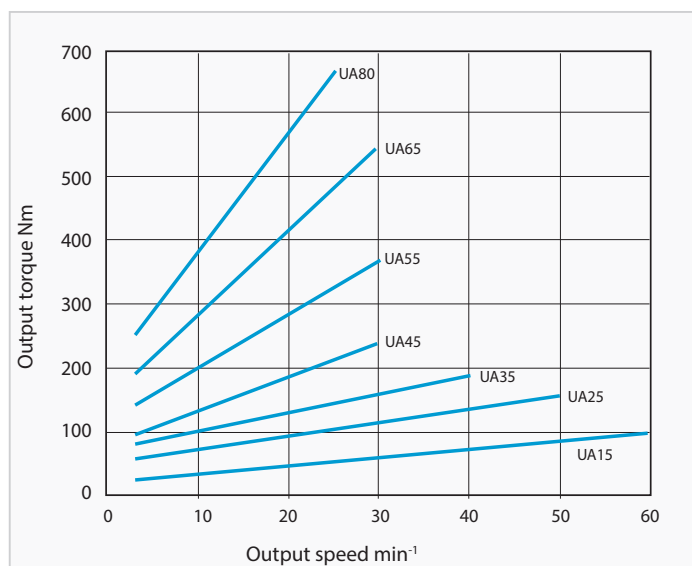

Fig. UA-1 Output side no-load running torque

Note 1. Fig. UA-1 shows the average no-load running torque after gearbox is run in (not factory-new condition).
2. Table UA-6 shows the measuring conditions.

Ring gear housing temperature	approx. 30 °C
Precision during assembly	as per 8.8.1
Lubrication	Standard lubrication

Table UA-6 Measurement conditions

Sold & Serviced By:



Toll Free Phone (877) SERV098
www.electromate.com
sales@electromate.com

8.5 Breakaway torque

Indicates the necessary torque for breakaway of the gearbox on the input or output side, after stop without output side load.

Breakaway torque on output side (BTO)

- Note**
1. Table UA-8 shows the max. breakaway torque on the output side BTO. Fine Cyclo gearboxes are not self-locking. The BTO is defined as the maximum value (factory-new condition), which steadily decreases during the lifetime.
 2. Table UA-7 shows the measuring conditions.

Size	Breakaway torque BTO [Nm]
UA15	< 20
UA25	< 49
UA35	< 88
UA45	< 108
UA55	< 137
UA65	< 167
UA80	< 196

Table UA-8 Value of the breakaway torque on the output side (BTO)

Breakaway torque on input side (BTI)

- Note**
1. Table UA-9 shows the max. breakaway torque BTI on the input side. BTI is defined as the maximum value (factory-new condition) which steadily decreases during the lifetime.
 2. The following equation is to be used to calculate the input torques of the idle time losses:

$$\text{Input torque} = \frac{\text{Output torque}}{\text{Ratio}}$$

3. Table UA-7 shows the measuring conditions.

Precision during assembly	as per 8.8.1
Lubrication	Standard lubrication

Table UA-7 Measurement conditions

Size	i	Breakaway torque BTI [Nm]
UA15	60	< 0.3
	84	< 0.3
	91	< 0.2
	127	< 0.1
	139	< 0.1
	171	< 0.1
UA25	78	< 0.6
	88	< 0.6
	115	< 0.4
	124	< 0.4
	145	< 0.3
	173	< 0.3
UA35	82	< 1.1
	87	< 1.0
	121	< 0.7
	152	< 0.6
	166	< 0.5
	82	< 1.3
UA45	99	< 1.1
	121	< 0.9
	130	< 0.8
	152	< 0.7
	166	< 0.7
UA55	81	< 1.7
	97	< 1.4
	126	< 1.1
	145	< 0.9
	169	< 0.8
UA65	241	< 0.6
	89	< 1.9
	121	< 1.4
	136	< 1.2
	144	< 1.2
	163	< 1.0
	171	< 1.0
199	< 0.8	
UA80	249	< 0.7
	93	< 2.1
	103	< 1.9
	122	< 1.6
	155	< 1.3
	166	< 1.2
	190	< 1.0
239	< 0.8	
283	< 0.7	

Table UA-9 Value of the breakaway torque on the input side (BTI)

8.6 Efficiency

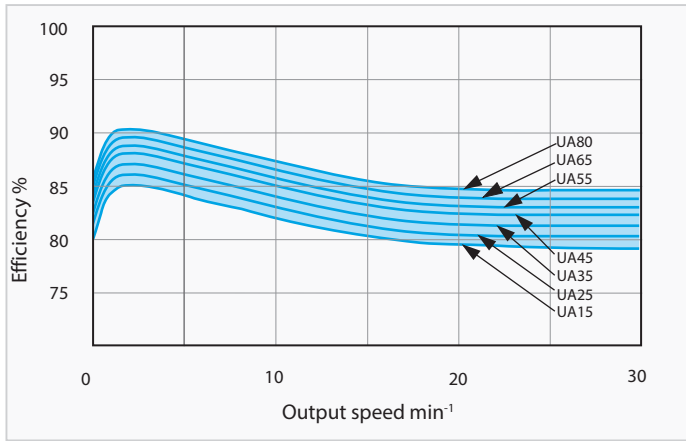

Fig. UA-2 Efficiency curve

Fig. UA-2 shows the efficiency of a run-in gearbox under nominal load at an ambient temperature of 20 °C. For more information, see "4 Description of technical specifications for cycloidal gearboxes" on page 22.

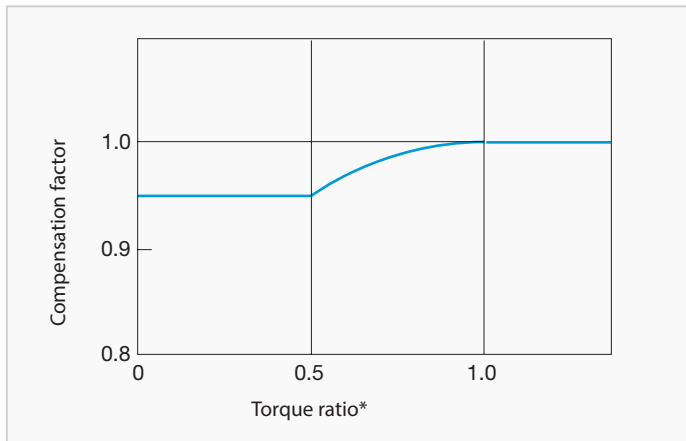

Fig. UA-3 Compensation curve for efficiency

$$* \text{Torque ratio} = \frac{\text{Load torque}}{\text{Nominal output torque}}$$

$$\text{Compensation efficiency} = \text{efficiency} \cdot \text{compensation factor}$$

- Note**
1. The efficiency changes if the load torque does not match the nominal torque. Check the compensation factor in the diagram Fig. UA-3.
 2. When the torque ratio is over 1.0, the compensation factor for efficiency is 1.0 (diagram Fig. UA-3).

Sold & Serviced By:



Toll Free Phone (877) SERV098
www.electromate.com
sales@electromate.com

8.7 Main bearing

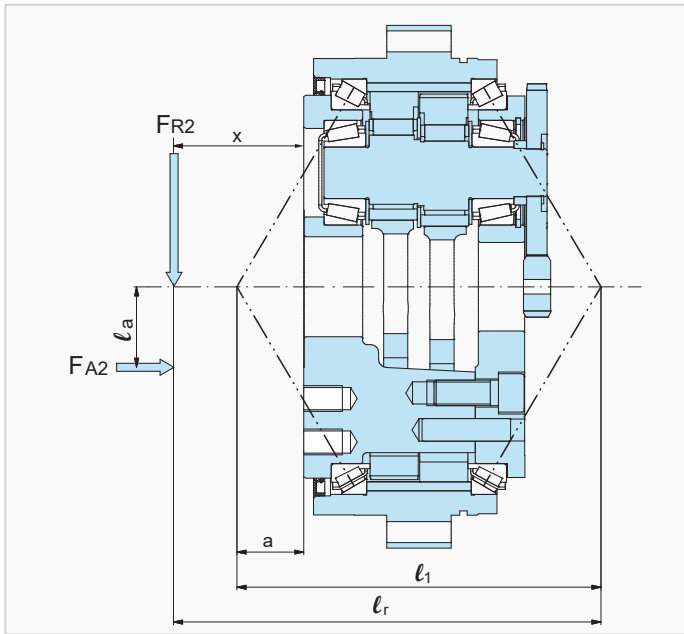

Fig. UA-4 Distance between the individual loading points

$$l_r = x - a + l_1 \quad \text{(Equation UA-4)}$$

1. Moment stiffness

The moment stiffness is the bending moment at which the output flange is tilted by the tilt angle.

The tilt angle of the input flange is determined as follows:

$$\varphi_1 = \frac{T_k}{\Theta_1} \quad \text{(Equation UA-5)}$$

External bending moment T_k

$$T_k = 10^{-3} \cdot (F_{R2} \cdot l_r + F_{A2} \cdot l_a) \quad \text{(Equation UA-6)}$$

2. Max. permissible bending moment and max. permissible axial load.

Check the external bending moment and the external axial load using equations UA-6, UA-7, UA-8 and Table UA-14.

Equivalent bending moment T_{ke}

$$T_{ke} = 10^{-3} \cdot (C_{f2} \cdot B_{f2} \cdot F_{R2} \cdot l_r + C_{f2} \cdot B_{f2} \cdot F_{A2} \cdot l_a) < T_{kmax} \quad \text{(Equation UA-7)}$$

Equivalent axial load F_{A2e} at the output shaft

$$F_{A2e} = F_{A2} \cdot C_{f2} \cdot B_{f2} < F_{A2max} \quad \text{(Equation UA-8)}$$

Size	Values of internal bearing distance	
	l_1 [mm]	a [mm]
UA15	114.2	20.4
UA25	131.9	26
UA35	154.5	34.8
UA45	177.5	38.7
UA55	205.7	50.9
UA65	183.4	32.7
UA80	215.1	35.9

Table UA-10 Bearing spacing dimensions [mm]

Note If: $l_r > 4 \cdot l_1$, please contact Sumitomo Drive Technologies.

Size	Moment stiffness Θ_1
	[Nm/arcmin]
UA15	550
UA25	833
UA35	1127
UA45	1500
UA55	2500
UA65	6000
UA80	9000

Table UA-11 Average values for moment stiffness

- F_{A2} = output side axial load [N]
- F_{A2max} = maximum permissible output side axial load [N]
- F_{A2e} = equivalent output side axial load [N]
- F_{R2} = output side radial load [N]
- C_{f2} = correction factor output (Table UA-12)
- B_{f2} = service factor output (Table UA-13)
- l_1 = bearing clearance [mm] (Table UA-10)
- l_r = calculated dimension for bending moment [mm]
- l_a = distance of axial load [mm]
- x = distance from radial force to flange collar [mm]
- a = correction factor [mm] (Table UA-10)
- T_k = external bending moment [Nm]
- T_{kmax} = maximum permissible bending moment [Nm] (Table UA-14)
- T_{ke} = equivalent bending moment [Nm]
- φ_1 = tilt angle [arcmin]
- Θ_1 = moment stiffness main bearing [Nm/arcmin] (Table UA-11)

Correction factor output	C_{f2}
Chain	1
Gear or pinion	1.25
Timing belt	1.25
V-Belt	1.5

Table UA-12 Correction factor output C_{f2}

Service factor output	B_{f2}
Uniform load (no shock)	1
Light impacts	1 – 1.2
Severe impacts	1.4 – 1.6

Table UA-13 Service factor output B_{f2}

Size	Max. permissible bending moment T_{kmax}	Max. permissible axial load F_{A2max}
	[Nm]	[N]
UA15	883	3924
UA25	1666	5194
UA35	2156	7840
UA45	3430	8820
UA55	4000	10780
UA65	7056	11000
UA80	10000	13734

Table UA-14 Max. permissible bending moment and max. permissible axial load

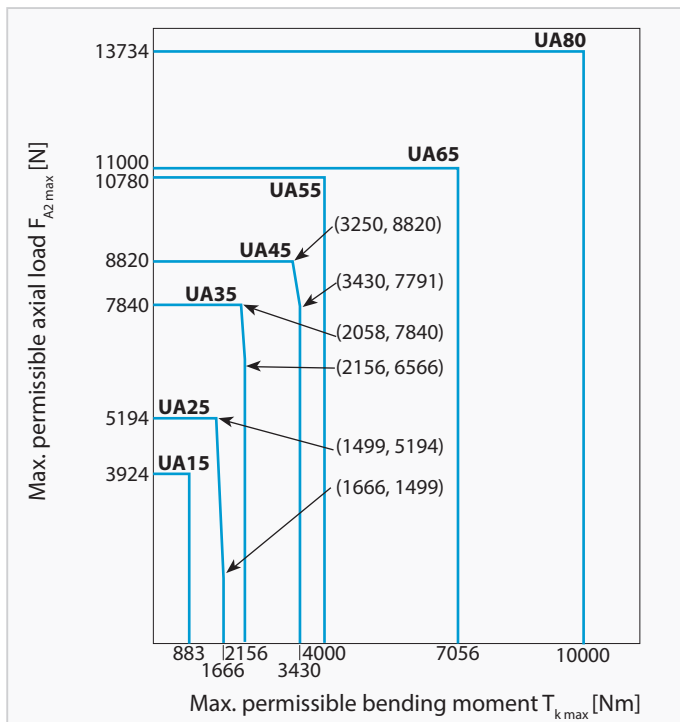

Fig. UA-5 Max. permissible bending moment and axial load

Sold & Serviced By:



Toll Free Phone (877) SERV098
www.electromate.com
sales@electromate.com

8.8 Assembly specifications and tolerances

8.8.1 Assembly tolerances

To ensure the function, lifetime, and characteristics of the gearbox, the radial run-out of the shaft ends, the coaxiality and the axial run-out of the fastening surface as per EN 50347:2001 are sufficient. When used in high-precision applications, the tolerance according to EN 50347:2001 should be reduced by 50%, which has additional advantages.

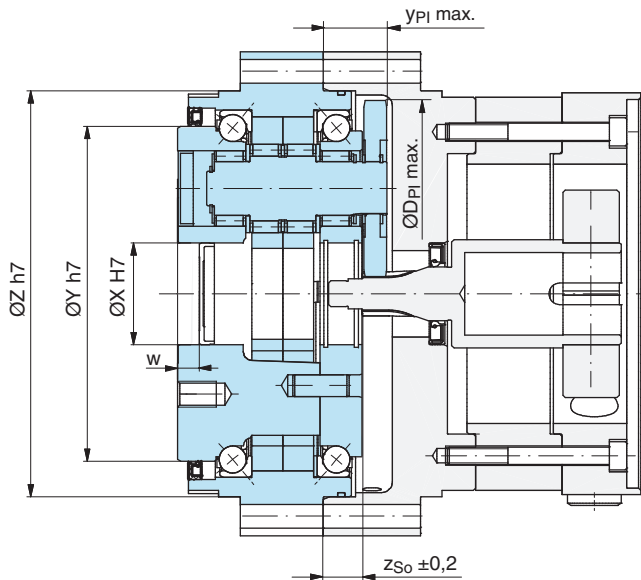

Size	Ø X	Ø Y	Ø Z	Ø DPI max.	yPI max.	zSo ± 0.2	w
UA15	28	90	113	104.5	28.4	19.0	6
UA25	32	110	137	124.3	29.5	18.5	8
UA35	35	130	160	143.2	31.5	18.5	8
UA45	47	155	188	179.0	30.2	18.0	8
UA55	42	174	208	199.7	32.8	17.5	8
UA65	55	210	255	231.3	41.0	26.5	10
UA80	62	238	284	262.7	60.7	46.0	10

Table UA-15 (Dimensions in mm)

Tightening torque and maximum permissible transmittable torque for bolts

The permissible transmitted torque for bolts and the number, size, and tightening torque for fastening the output side flange and the ring gear housing are listed in Table UA-16. In the event of an Emergency Stop with corresponding load peaks, the output flange and ring gear housing bolts must all be replaced. Liquid sealing material must be applied between all fittings of the gearbox with the customer's applications.

Size	Output flange bolts				Bolts for ring gear (housing)		
	Number and size of bolts	Pitch circle- Ø	Tightening torque [Nm]	Max. permissible transmittable torque for bolts [Nm]	Number and size of bolts	Tightening torque [Nm]	Max. permissible transmittable torque for bolts [Nm]
UA15	15 × M6 9 × M6	72 48	15.7	1505	16 × M5	9.1	1389
UA25	9 × M10 6 × M0	86 50	76.5	3083	12 × M8	38.3	3283
UA35	15 × M10 6 × M10	107 72	76.5	5848	18 × M8	38.3	5707
UA45	18 × M10 9 × M12	131 93	76.5 133	10262	18 × M10	76.5	10646
UA55	15 × M12 9 × M12	140 97	133	12406	20 × M10	76.5	12977
UA65	21 × M12 12 × M12	177 136	133	22321	18 × M12	133	20656
UA80	15 × M16 9 × M16	193 139	331	32221	24 × M12	133	30545

Table UA-16 Bolt tightening torque and permissible torque values

- **Bolting:** Use metric hexagon socket head screws (DIN 4762, strength category 12.9).
- **Countermeasure for bolts loosening:** Use adhesives (Loctite 262, etc.) or spring washer (DIN 127A).
- **Use spring washers** (DIN 6796) when connecting the gearbox to the flange side, so that the bolt contact faces do not get damaged.

8.8.2 Installation example

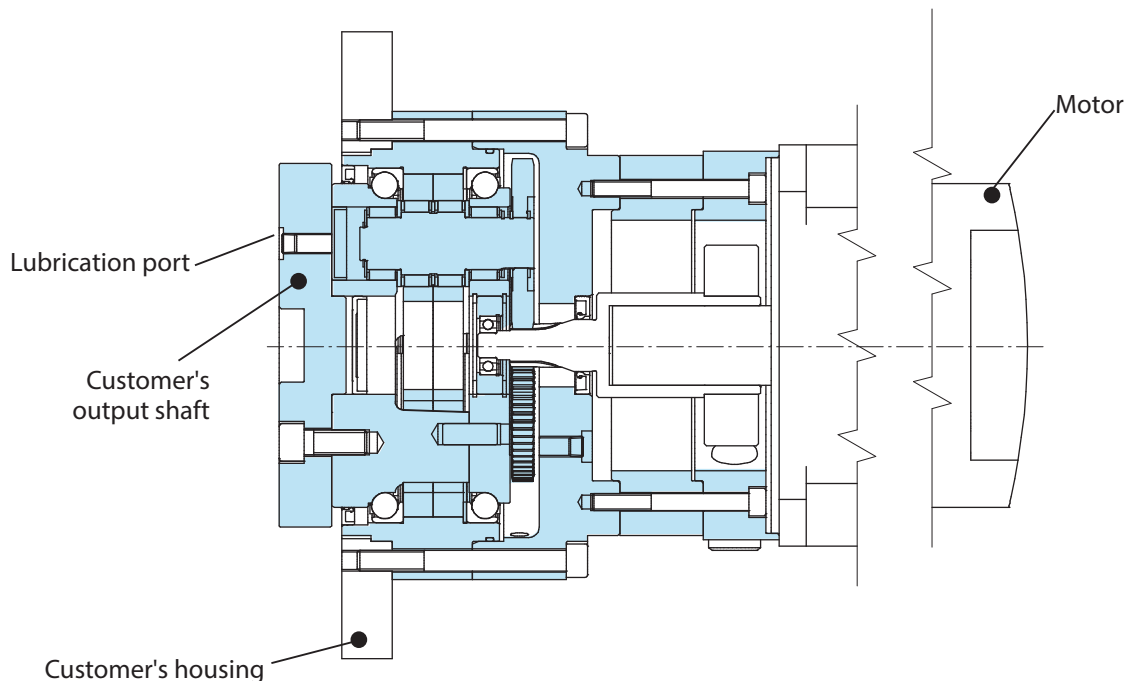

The customer's output shaft is bolted to the output flange of the gearbox.

Motor mounting different from catalogue standard:
 The correct penetration depth of the gearing (shaft distance from output) must be observed as per the Fine Cyclo catalogue (see the dimension sheets).

Sold & Serviced By:

 Toll Free Phone (877) SERV098
www.electromate.com
sales@electromate.com

8.8.3 Lubrication

- Differing from the standard, type F2/4CF-UA Fine Cyclo gearboxes are delivered without grease and must therefore be filled with Multemp FZ No.00 grease as specified in Table UA-178 and sealed before commissioning (for grease filling port, see illustration). These greases are suitable for ambient temperatures from -10 °C to +40 °C.
- Reconditioning is recommended after 20,000 operating hours, but at least every 3-5 years.
- UA-Modular as per the standard catalogue version are designed for lubrication in any mounting position.

Size	Quantity of grease [g]			A [mm]	B [mm]
	Horizontal	Vertical 1	Vertical 2		
UA15	122	152	143	29	33
UA25	209	261	227	34	34
UA35	313	400	361	39	45
UA45	383	487	417	49	50
UA55	679	818	748	54	65
UA65	940	1180	1090	63	74
UA80	1700	2140	1995	71	75

Table UA-18 Lubrication

The grease quantity above relates to the gearbox. The cavity between the gearbox and the motor (motor adapter) must also be taken into account.

Specified grease	Manufacturer
Multemp FZ No. 00	Kyodo Yushi Co., Ltd.
Conditions for use: Ambient temperature -10 °C to +40 °C	

Table UA-17 Specified grease for the UA Series

Mounting position
Horizontal
Additional amount of grease for flange:
50% of the cavity

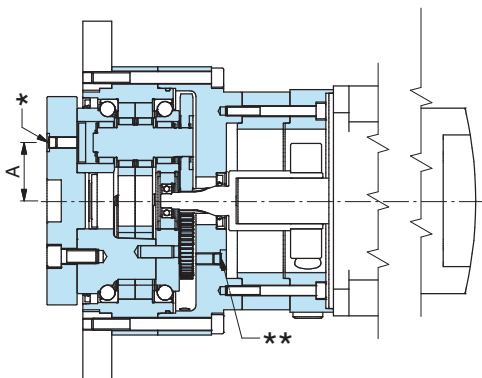

Mounting position
Vertical 1
Output down
Additional amount of grease for flange:
0% of the cavity

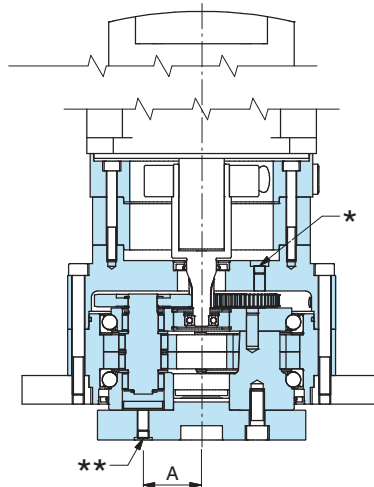

Mounting position
Vertical 2
Output up
Additional amount of grease for flange:
100% of the cavity

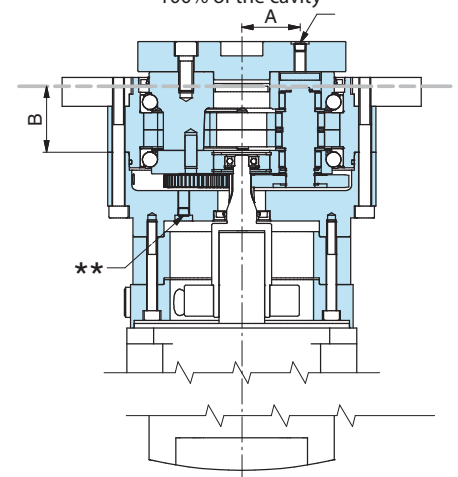

- * Filling port for grease
- ** Grease drain port for changing the grease

Determination of the cavity

The additional amount of grease is necessary for the functioning of the gearbox.

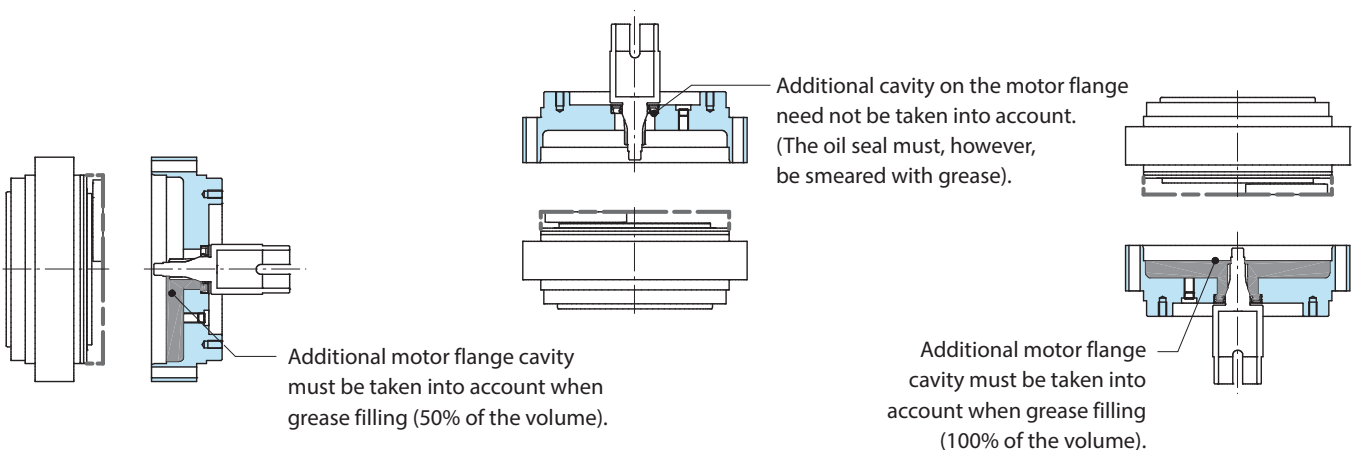

8.9 Dimensioned drawings

F4CF-UA15

Mass 4 kg

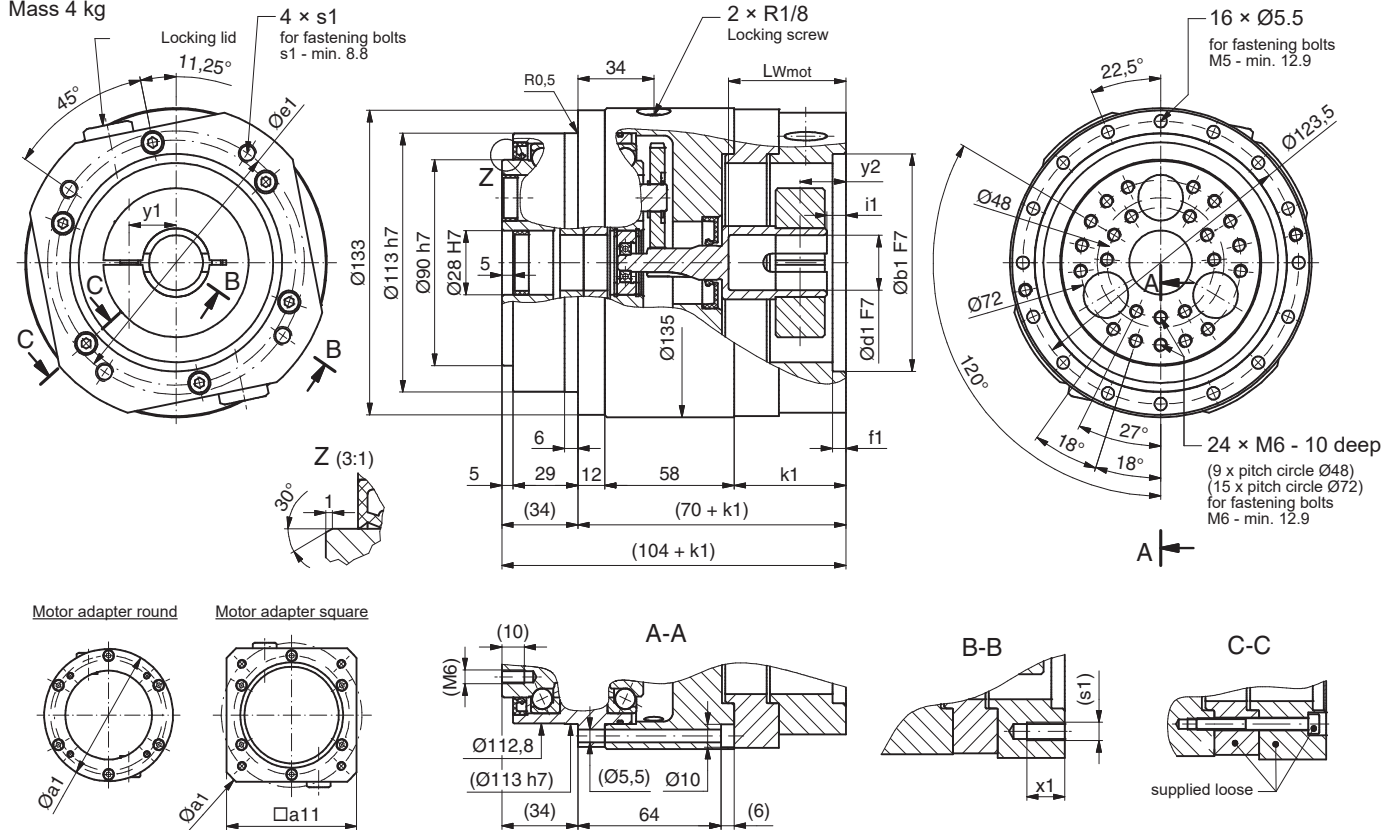

Motor mounting dimensions F4CF- UA15

Motor code	Hole for shaft	Min./Max. Length of motor shaft	Centering F7	Spigot seat depth	Pitch circle Ø	Thread in gearbox flange	Thread depth	Flange diameter	Flange square dimension	Flange width	Shaft recess	Positional dimensions locking lid	
	Ød1	L _{wMot} min/max	Øb1	f1	Øe1	4x s1	x1	Øa1	□a11	k1	i1	y1	y2
mm													
C06G	9	24.0 / 30.5	40	5.5	63	M4	7.5	119	-	29	7.5	17	16.5
C08G		24.0 / 30.5	40	5.5	63	M5	7.5	119	-	29	7.5	17	16.5
C11G		24.0 / 30.5	60	5.5	75	M5	7.5	119	-	29	7.5	18.5	16.5
D30G	10	25.0 / 31.5	80	6	100	M6	14	119	-	30	8.5	18.5	16.5
E10G	11	24.0 / 30.5	50	5.5	70	M4	7.5	119	-	29	7.5	17	16.5
E11G		24.0 / 30.5	60	5.5	75	M5	7.5	119	-	29	7.5	18.5	16.5
F25G	12	24.0 / 30.5	50	5.5	70	M5	7.5	119	-	29	7.5	17	16.5
F17G		25.5 / 32.0	70	6	90	M5	12	119	-	30.5	9	18.5	17
H10G	14	24.0 / 30.5	50	5.5	70	M4	7.5	119	-	29	7.5	17	16.5
H25G		24.0 / 30.5	50	5.5	70	M5	7.5	119	-	29	7.5	17	16.5
H20G		24.0 / 30.5	50	6	95	M6	14	119	-	29	7.5	17	16.5
H30G		25.0 / 31.5	80	6	100	M6	14	119	-	30	8.5	18.5	16.5
H50G		25.0 / 31.5	110	6	130	M8	17	158	120	30	8.5	25	18
H60L		36.5 / 43.0	110	8	145	M8	17	158	120	41.5	20	25	29.5
J30G	16	29.5 / 31.5	80	6	100	M6	14	119	-	30	8.5	18.5	16.5
J60G		29.5 / 31.5	110	6.5	145	M8	17	158	120	30	8.5	25	18
M17G	19	30.0 / 42.0	70	6	90	M5	12	119	-	40.5	9	18.5	17
M18G		30.0 / 42.0	70	6	90	M5	12	119	-	40.5	9	18.5	17
M30G		29.5 / 41.5	80	6	100	M6	14	119	-	40	8.5	18.5	16.5
M50G		29.5 / 41.5	110	6	130	M8	17	158	120	40	8.5	25	18
M70G		29.5 / 41.5	130	6	165	M10	20	188	144	40	8.5	25	18
N30G	22	31.5 / 41.5	80	6	100	M6	14	119	-	40	8.5	18.5	16.5
N60G		31.5 / 41.5	110	6.5	145	M8	17	158	120	40	8.5	25	18
N70G		31.5 / 41.5	130	6	165	M10	20	188	144	40	8.5	25	18
Z30G	24	31.5 / 51.5	80	6	100	M6	14	119	-	50	8.5	18.5	16.5
Z45G		31.5 / 51.5	95	6	115	M8	17	158	120	50	8.5	18.5	18
Z70G		31.5 / 51.5	130	6	165	M10	20	188	144	50	8.5	25	18

Note Other motor mounting dimensions available on request.

F4CF-UA25

Mass 6 kg

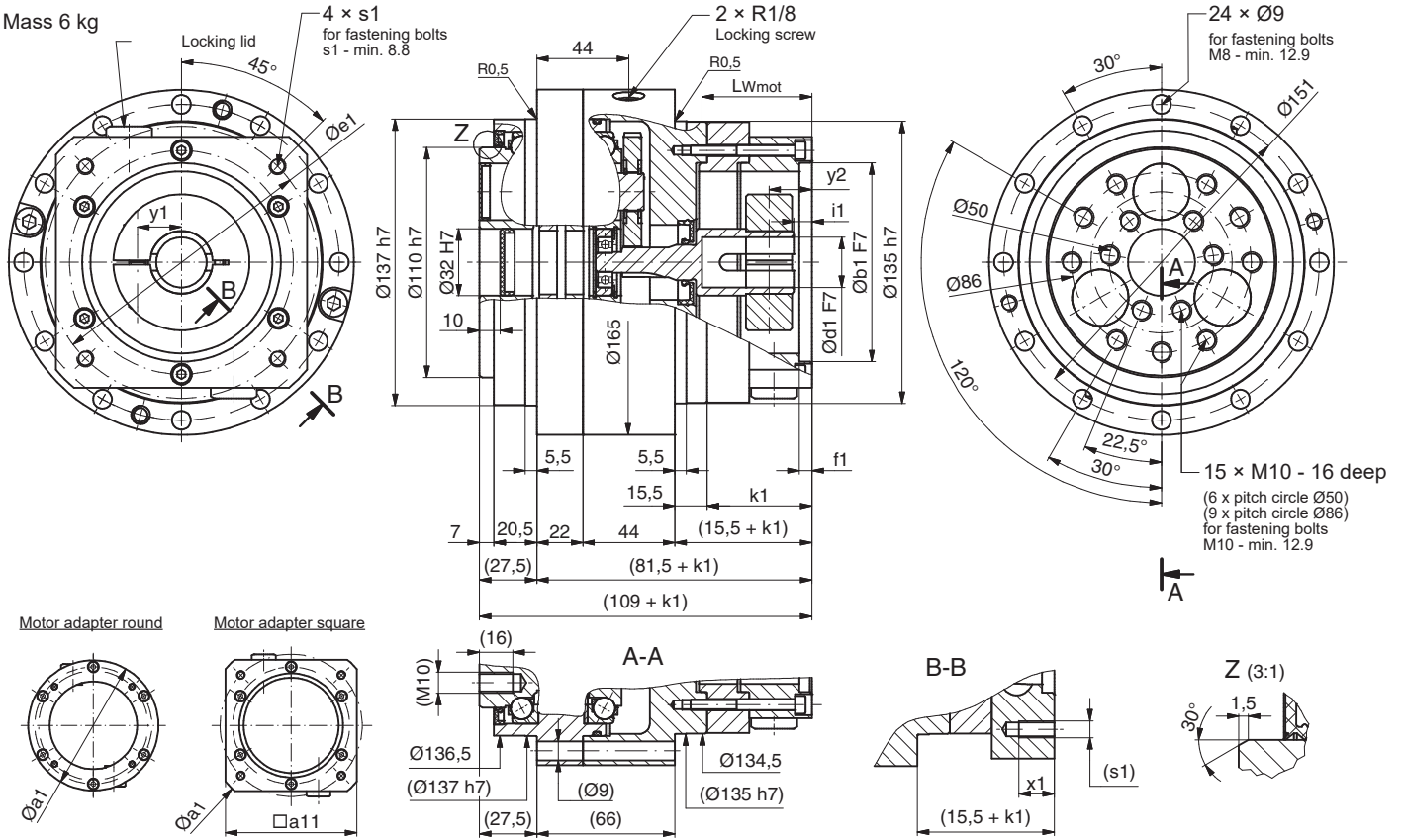

Motor mounting dimensions F4CF- UA25

Motor code	Hole for shaft Ød1	Min./Max. Length of motor shaft L _{wMot} min/max	Centering F7 Øb1	Spigot seat depth f1	Pitch circle Ø Øe1	Thread in gearbox flange 4x s1	Thread depth x1	Flange diameter Øa1	Flange square dimension □a11	Flange width k1	Shaft recess i1	Positional dimensions locking lid y1 y2	
mm													
D30G	10	25.0 / 31.5	80	6	100	M6	14	119	-	30	8.5	18.5	16.5
E10G	11	24.0 / 30.5	50	5.5	70	M4	7.5	119	-	29	7.5	17	16.5
E11G		24.0 / 30.5	60	5.5	75	M5	7.5	119	-	29	7.5	18.5	16.5
F25G	12	24.0 / 30.5	50	5.5	70	M5	7.5	119	-	29	7.5	17	16.5
F17G		25.5 / 32.0	70	6	90	M5	12	119	-	30.5	9	18.5	17
H10G	14	24.0 / 30.5	50	5.5	70	M4	7.5	119	-	29	7.5	17	16.5
H25G		24.0 / 30.5	50	5.5	70	M5	7.5	119	-	29	7.5	17	16.5
H20G		24.0 / 30.5	50	6	95	M6	14	119	-	29	7.5	17	16.5
H30G		25.0 / 31.5	80	6	100	M6	14	119	-	30	8.5	18.5	16.5
H50G		25.0 / 31.5	110	6	130	M8	17	158	120	30	8.5	25	18
H60L		36.5 / 43.0	110	8	145	M8	17	158	120	41.5	20	25	29.5
J30G	16	29.5 / 31.5	80	6	100	M6	14	119	-	30	8.5	18.5	16.5
J60G		29.5 / 31.5	110	6.5	145	M8	17	158	120	30	8.5	25	18
M17G	19	30.0 / 42.0	70	6	90	M5	12	119	-	40.5	9	18.5	17
M18G		30.0 / 42.0	70	6	90	M5	12	119	-	40.5	9	18.5	17
M30G		29.5 / 41.5	80	6	100	M6	14	119	-	40	8.5	18.5	16.5
M35G		29.5 / 41.5	95	6	115	M8	17	138	120	40	8.5	18.5	18
M50G		29.5 / 41.5	110	6	130	M8	17	158	120	40	8.5	25	18
M70G		29.5 / 41.5	130	6	165	M10	20	188	144	40	8.5	25	18
N30G	22	31.5 / 41.5	80	6	100	M6	14	119	-	40	8.5	18.5	16.5
N60G		31.5 / 41.5	110	6.5	145	M8	17	158	120	40	8.5	25	18
N70G		31.5 / 41.5	130	6	165	M10	20	188	144	40	8.5	25	18
Z30G	24	31.5 / 51.5	80	6	100	M6	14	119	-	50	8.5	18.5	16.5
Z45G		31.5 / 51.5	95	6	115	M8	17	158	120	50	8.5	18.5	18
Z70G		31.5 / 51.5	130	6	165	M10	20	188	144	50	8.5	25	18

Note Other motor mounting dimensions available on request.

F4CF-UA35

Mass 11 kg

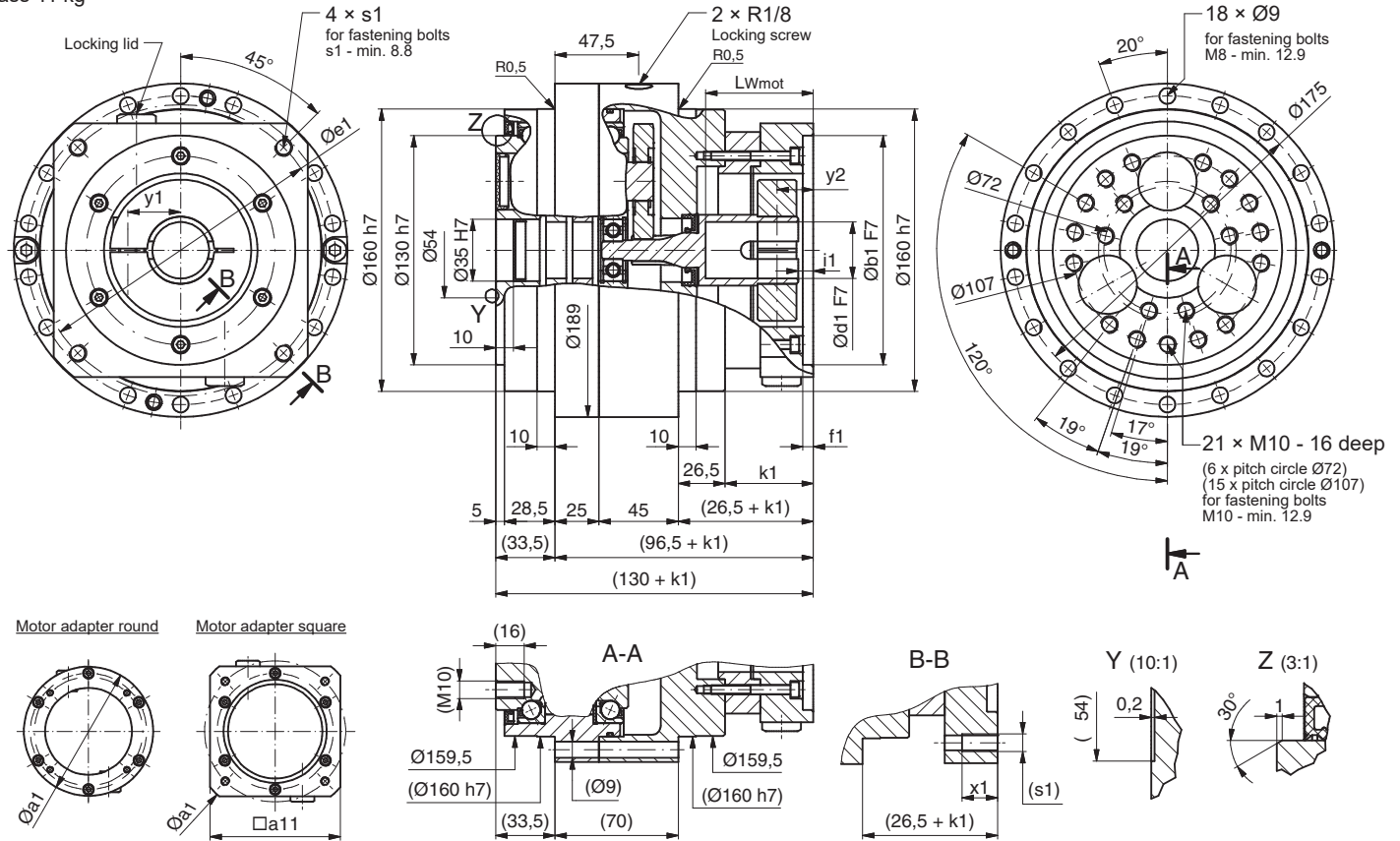

Motor mounting dimensions F4CF- UA35

Motor code	Hole for shaft Ød1	Min./Max. Length of motor shaft L _{wMot} min/max	Centering F7 Øb1	Spigot seat depth f1	Pitch circle Ø Øe1	Thread in gearbox flange 4x s1	Thread depth x1	Flange diameter Øa1	Flange square dimension □a11	Flange width k1	Shaft recess i1	Positional dimensions locking lid y1 y2	
mm													
D30G	10	25.0 / 41.0	80	6	100	M6	14	119	-	30	8.5	18.5	16.5
E10G	11	24.0 / 40.0	50	5.5	70	M4	7.5	119	-	29	7.5	17	16.5
E11G		24.0 / 40.0	60	5.5	75	M5	7.5	119	-	29	7.5	18.5	16.5
F25G	12	24.0 / 40.0	50	5.5	70	M5	7.5	119	-	29	7.5	17	16.5
F17G		25.5 / 41.5	70	6	90	M5	12	119	-	30.5	9	18.5	17
H10G	14	24.0 / 40.0	50	5.5	70	M4	7.5	119	-	29	7.5	17	16.5
H25G		24.0 / 40.0	50	5.5	70	M5	7.5	119	-	29	7.5	17	16.5
H20G		24.0 / 40.0	50	6	95	M6	14	119	-	29	7.5	17	16.5
H30G		25.0 / 41.0	80	6	100	M6	14	119	-	30	8.5	18.5	16.5
H50G		25.0 / 41.0	110	6	130	M8	17	158	120	30	8.5	25	18
H60L		36.5 / 52.5	110	8	145	M8	17	158	120	41.5	20	25	29.5
J30G	16	29.5 / 41.0	80	6	100	M6	14	119	-	30	8.5	18.5	16.5
J60G		29.5 / 41.0	110	6.5	145	M8	17	158	120	30	8.5	25	18
M17G	19	30.0 / 41.5	70	6	90	M5	12	119	-	30.5	9	18.5	17
M18G		30.0 / 41.5	70	6	90	M5	12	119	-	30.5	9	18.5	17
M30G		29.5 / 41.0	80	6	100	M6	14	119	-	30	8.5	18.5	16.5
M35G		29.5 / 41.0	95	6	115	M8	17	138	120	30	8.5	18.5	18
M50G		29.5 / 41.0	110	6	130	M8	17	158	120	30	8.5	25	18
M70G		29.5 / 41.0	130	6	165	M10	20	188	144	30	8.5	25	18
N30G	22	31.5 / 41.0	80	6	100	M6	14	119	-	30	8.5	18.5	16.5
N60G		31.5 / 41.0	110	6.5	145	M8	17	158	120	30	8.5	25	18
N70G		31.5 / 41.0	130	6	165	M10	20	188	144	30	8.5	25	18
Z30G	24	31.5 / 51.0	80	6	100	M6	14	119	-	40	8.5	18.5	16.5
Z45G		31.5 / 51.0	95	6	115	M8	17	158	120	40	8.5	18.5	18
Z70G		31.5 / 51.0	130	6	165	M10	20	188	144	40	8.5	25	18
U80G	38	31.5 / 81.5	180	6.5	215	M12	23	237	186	70	9.0	30	21.5

Note Other motor mounting dimensions available on request.

F4CF-UA45

Mass 17 kg

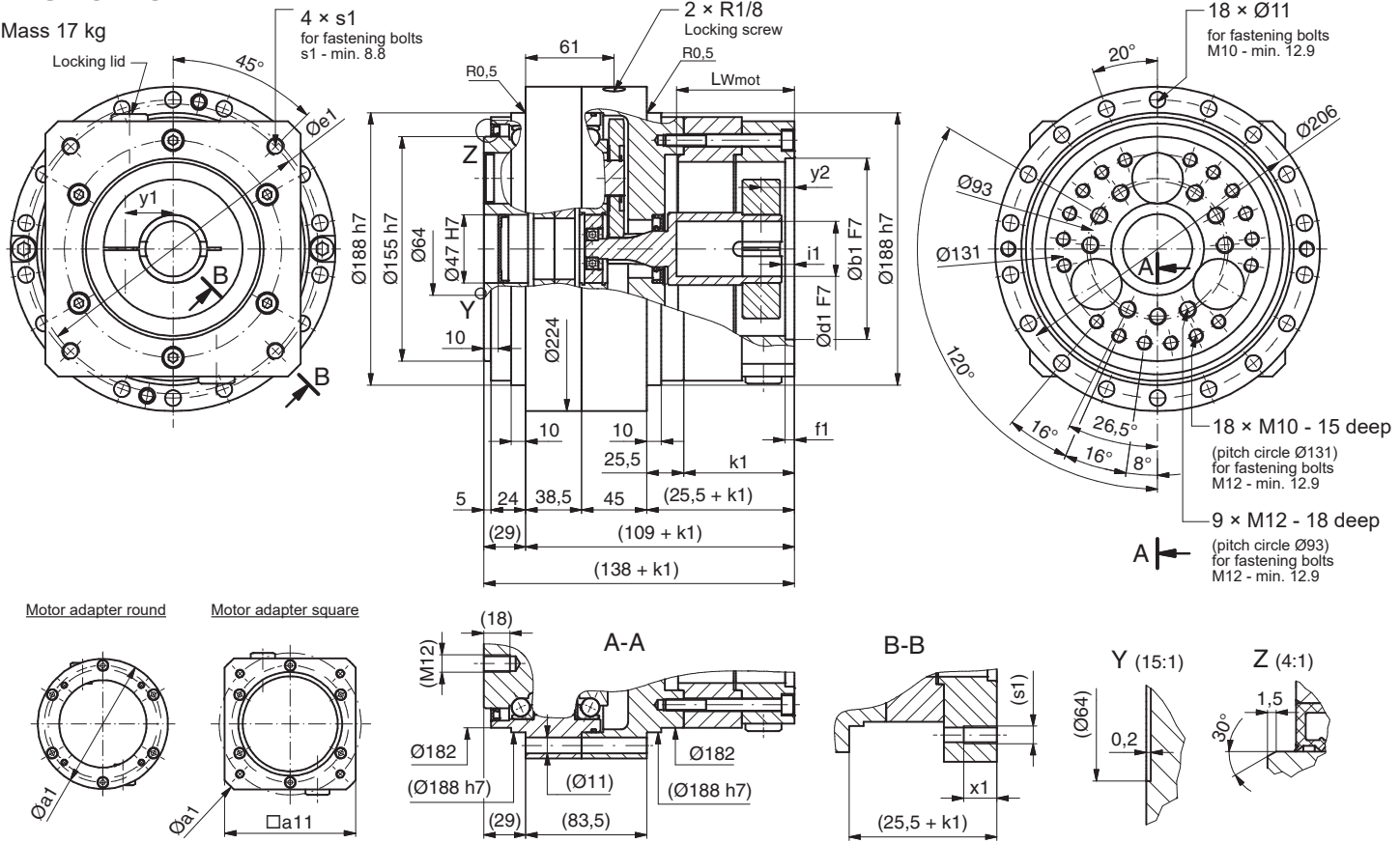

Motor adapter round

Motor adapter square

Motor mounting dimensions F4CF- UA45

Motor code	Hole for shaft	Min./Max. Length of motor shaft	Centering F7	Spigot seat depth	Pitch circle Ø	Thread in gearbox flange	Thread depth	Flange diameter	Flange square dimension	Flange width	Shaft recess	Positional dimensions locking lid	
	Ød1	L _{wMot} min/max	Øb1	f1	Øe1	4x s1	x1	Øa1	□a11	k1	i1	y1	y2
mm													
H17G	14	30.0 / 41.5	70	9	90	M5	12	169	-	36.5	9	18.5	20
H30G		29.5 / 41.0	80	6	100	M6	14	169	-	36	8.5	24	20.5
H50G		29.5 / 41.0	110	6	130	M8	17	169	-	36	8.5	24	20.5
H60L		41.0 / 52.5	110	6	145	M8	17	169	-	47.5	20	25	32
J30G	16	29.5 / 41.0	80	6	100	M6	14	169	-	36	8.5	24	20.5
J60G		29.5 / 41.0	110	6	145	M8	17	169	-	36	8.5	25	20.5
M17G	19	30.0 / 41.5	70	9	90	M5	12	169	-	36.5	9	18.5	20
M18G		30.0 / 41.5	70	9	90	M5	12	169	-	36.5	9	18.5	20
M30G		29.5 / 41.0	80	6	100	M6	14	169	-	36	8.5	24	20.5
M35G		29.5 / 41.0	95	6	115	M8	17	169	-	36	8.5	24	20.5
M50G		29.5 / 41.0	110	6	130	M8	17	169	-	36	8.5	24	20.5
M70G		29.5 / 41.0	130	8	165	M10	20	188	-	36	8.5	25	20.5
N30G	22	29.5 / 51.0	80	6	100	M6	14	169	-	46	8.5	24	20.5
N60G		29.5 / 51.0	110	6	145	M8	17	169	-	46	8.5	25	20.5
N70G		29.5 / 51.0	130	8	165	M10	20	188	-	46	8.5	25	20.5
Z30G	24	29.5 / 51.0	80	6	100	M6	14	169	-	46	8.5	24	20.5
Z35G		29.5 / 51.0	95	6	115	M8	17	169	-	46	8.5	24	20.5
Z50G		29.5 / 51.0	110	6	130	M8	17	169	-	46	8.5	24	20.5
Z70G		29.5 / 51.0	130	8	165	M10	20	188	-	46	8.5	25	20.5
Q50G	28	31.5 / 61.0	110	6	130	M8	17	169	-	56	8.5	24	20.5
Q70G		31.5 / 61.0	130	8	165	M10	20	188	-	56	8.5	25	20.5
Q76G		37.0 / 66.5	114.3	6	200	M12	23	223	176	61.5	14	33	26.5
S70G	32	31.5 / 61.0	130	8	165	M10	20	188	-	56	8.5	25	20.5
S88G		32.0 / 61.5	130	8	215	M12	23	237	186	56.5	9	30	21.5
T76G	35	37.0 / 86.5	114.3	6	200	M12	23	223	176	81.5	14	33	26.5
U80G	38	32.0 / 81.5	180	6.5	215	M12	23	237	168	76.5	9	30	21.5

Note Other motor mounting dimensions available on request.

F4CF-UA55

Mass 22 kg

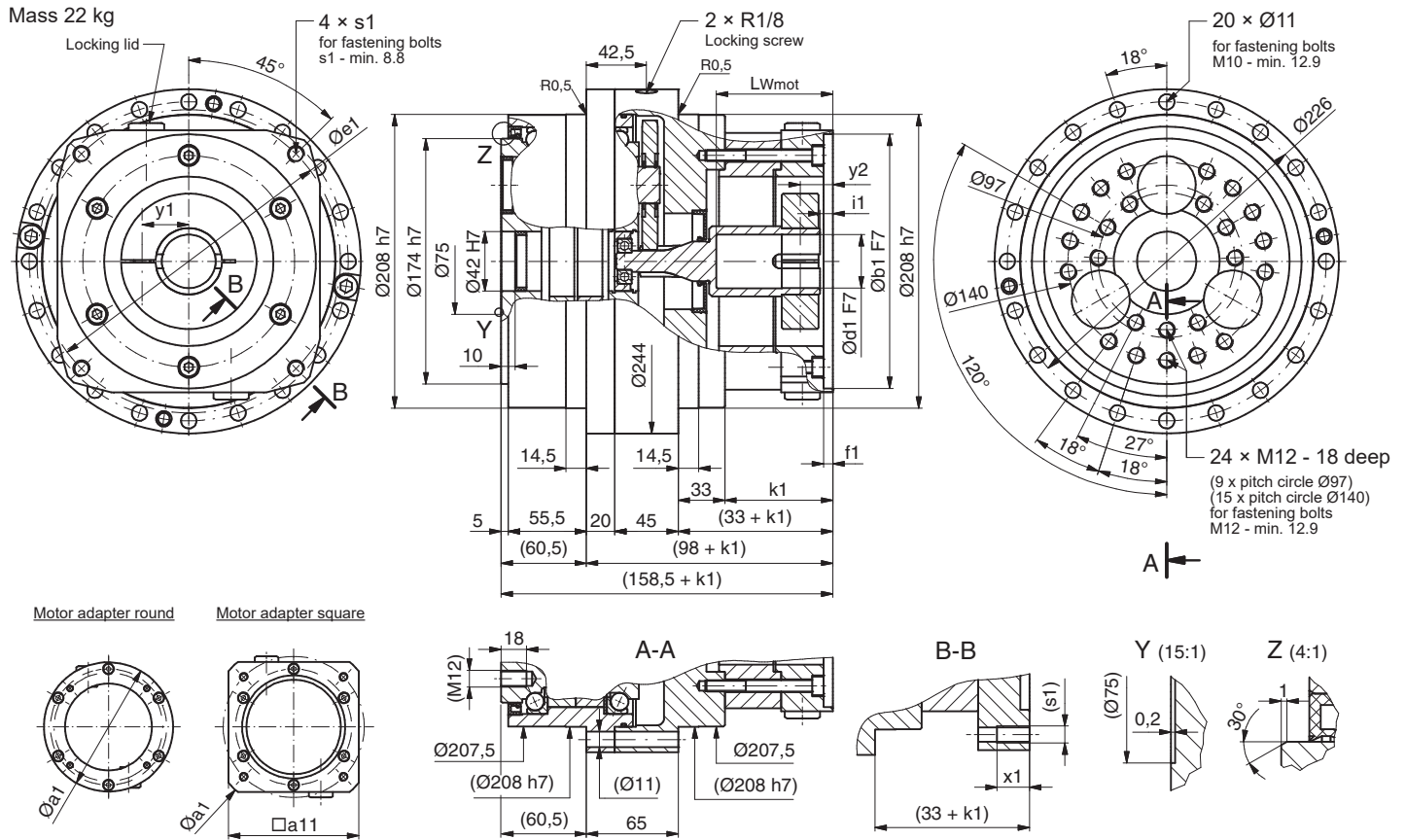

Motor mounting dimensions F4CF- UA55

Motor code	Hole for shaft	Min./Max. Length of motor shaft	Centering F7	Spigot seat depth	Pitch circle Ø	Thread in gearbox flange	Thread depth	Flange diameter	Flange square dimension	Flange width	Shaft recess	Positional dimensions locking lid	
	Ød1	L _{W Mot} min/max	Øb1	f1	Øe1	4x s1	x1	Øa1	□a11	k1	i1	y1	y2
mm													
H17G	14	30.0 / 41.5	70	9	90	M5	12	169	-	36.5	9	18.5	20
H30G		29.5 / 41.0	80	6	100	M6	14	169	-	36	8.5	24	20.5
H50G		29.5 / 41.0	110	6	130	M8	17	169	-	36	8.5	24	20.5
H60L		41.0 / 52.5	110	6	145	M8	17	169	-	47.5	20	25	32
J30G	16	29.5 / 41.0	80	6	100	M6	14	169	-	36	8.5	24	20.5
J60G		29.5 / 41.0	110	6	145	M8	17	169	-	36	8.5	25	20.5
M17G	19	30.0 / 41.5	70	9	90	M5	12	169	-	36.5	9	18.5	20
M18G		30.0 / 41.5	70	9	90	M5	12	169	-	36.5	9	18.5	20
M30G		29.5 / 41.0	80	6	100	M6	14	169	-	36	8.5	24	20.5
M35G		29.5 / 41.0	95	6	115	M8	17	169	-	36	8.5	24	20.5
M50G		29.5 / 41.0	110	6	130	M8	17	169	-	36	8.5	24	20.5
M70G		29.5 / 41.0	130	8	165	M10	20	188	-	36	8.5	25	20.5
N30G	22	29.5 / 51.0	80	6	100	M6	14	169	-	46	8.5	24	20.5
N60G		29.5 / 51.0	110	6	145	M8	17	169	-	46	8.5	25	20.5
N70G		29.5 / 51.0	130	8	165	M10	20	188	-	46	8.5	25	20.5
Z30G	24	29.5 / 51.0	80	6	100	M6	14	169	-	46	8.5	24	20.5
Z35G		29.5 / 51.0	95	6	115	M8	17	169	-	46	8.5	24	20.5
Z50G		29.5 / 51.0	110	6	130	M8	17	169	-	46	8.5	24	20.5
Z70G		29.5 / 51.0	130	8	165	M10	20	188	-	46	8.5	25	20.5
Q50G	28	31.5 / 61.0	110	6	130	M8	17	169	-	56	8.5	24	20.5
Q70G		31.5 / 61.0	130	8	165	M10	20	188	-	56	8.5	25	20.5
Q76G		37.0 / 66.5	114.3	6	200	M12	23	223	176	61.5	14	33	26.5
S70G	32	31.5 / 61.0	130	8	165	M10	20	188	-	56	8.5	25	20.5
S88G		32.0 / 61.5	130	8	215	M12	23	237	186	56.5	9	30	21.5
T76G	35	37.0 / 86.5	114.3	6	200	M12	23	223	176	81.5	14	33	26.5
U80G	38	32.0 / 81.5	180	6.5	215	M12	23	237	168	76.5	9	30	21.5

Note Other motor mounting dimensions available on request.

F2CF-UA65

Mass 38 kg

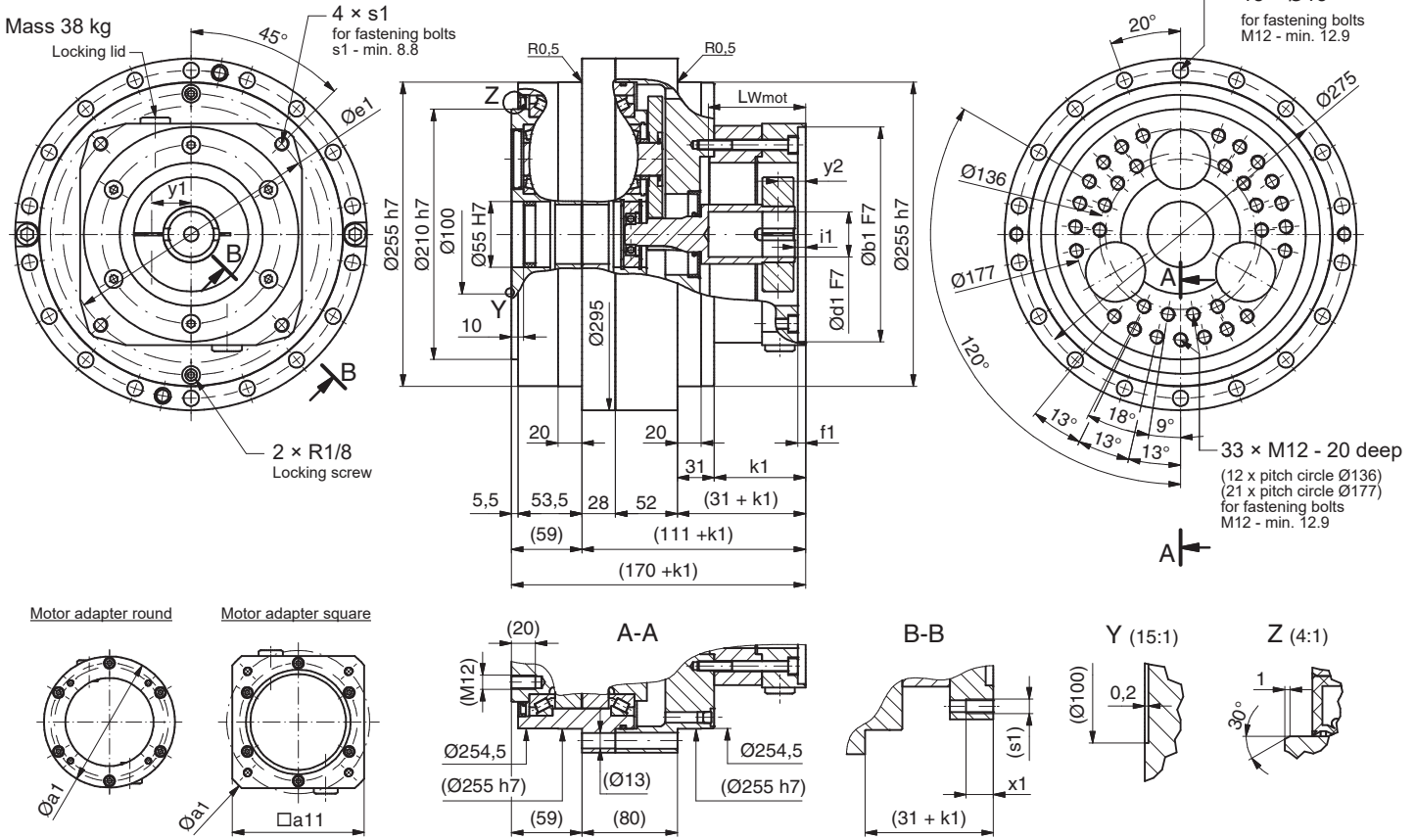

Motor mounting dimensions F2CF- UA65

Motor code	Hole for shaft	Min./Max. Length of motor shaft	Centering F7	Spigot seat depth	Pitch circle Ø	Thread in gearbox flange	Thread depth	Flange diameter	Flange square dimension	Flange width	Shaft recess	Positional dimensions locking lid	
	Ød1	L _{wMot} min/max	Øb1	f1	Øe1	4x s1	x1	Øa1	□a11	k1	i1	y1	y2
mm													
H17G	14	30.0 / 41.5	70	9	90	M5	12	169	-	36.5	9	18.5	20
H30G		29.5 / 41.0	80	6	100	M6	14	169	-	36	8.5	24	20.5
H50G		29.5 / 41.0	110	6	130	M8	17	169	-	36	8.5	24	20.5
H60L		41.0 / 52.5	110	6	145	M8	17	169	-	47.5	20	25	32
J30G	16	29.5 / 41.0	80	6	100	M6	14	169	-	36	8.5	24	20.5
J60G		29.5 / 41.0	110	6	145	M8	17	169	-	36	8.5	25	20.5
M17G	19	30.0 / 41.5	70	9	90	M5	12	169	-	36.5	9	18.5	20
M18G		30.0 / 41.5	70	9	90	M5	12	169	-	36.5	9	18.5	20
M30G		29.5 / 41.0	80	6	100	M6	14	169	-	36	8.5	24	20.5
M35G		29.5 / 41.0	95	6	115	M8	17	169	-	36	8.5	24	20.5
M50G		29.5 / 41.0	110	6	130	M8	17	169	-	36	8.5	24	20.5
M70G		29.5 / 41.0	130	8	165	M10	20	188	-	36	8.5	25	20.5
N30G	22	29.5 / 51.0	80	6	100	M6	14	169	-	46	8.5	24	20.5
N60G		29.5 / 51.0	110	6	145	M8	17	169	-	46	8.5	25	20.5
N70G		29.5 / 51.0	130	8	165	M10	20	188	-	46	8.5	25	20.5
Z30G	24	29.5 / 51.0	80	6	100	M6	14	169	-	46	8.5	24	20.5
Z35G		29.5 / 51.0	95	6	115	M8	17	169	-	46	8.5	24	20.5
Z50G		29.5 / 51.0	110	6	130	M8	17	169	-	46	8.5	24	20.5
Z70G		29.5 / 51.0	130	8	165	M10	20	188	-	46	8.5	25	20.5
Q50G	28	31.5 / 61.0	110	6	130	M8	17	169	-	56	8.5	24	20.5
Q70G		31.5 / 61.0	130	8	165	M10	20	188	-	56	8.5	25	20.5
Q76G		37.0 / 66.5	114.3	6	200	M12	23	223	176	61.5	14	33	26.5
S70G	32	31.5 / 61.0	130	8	165	M10	20	188	-	56	8.5	25	20.5
S88G		32.0 / 61.5	130	8	215	M12	23	237	186	56.5	9	30	21.5
T76G	35	37.0 / 86.5	114.3	6	200	M12	23	223	176	81.5	14	33	26.5
U80G	38	32.0 / 81.5	180	6.5	215	M12	23	237	168	76.5	9	30	21.5

Note Other motor mounting dimensions available on request.

F2CF-UA80

Mass 56 kg

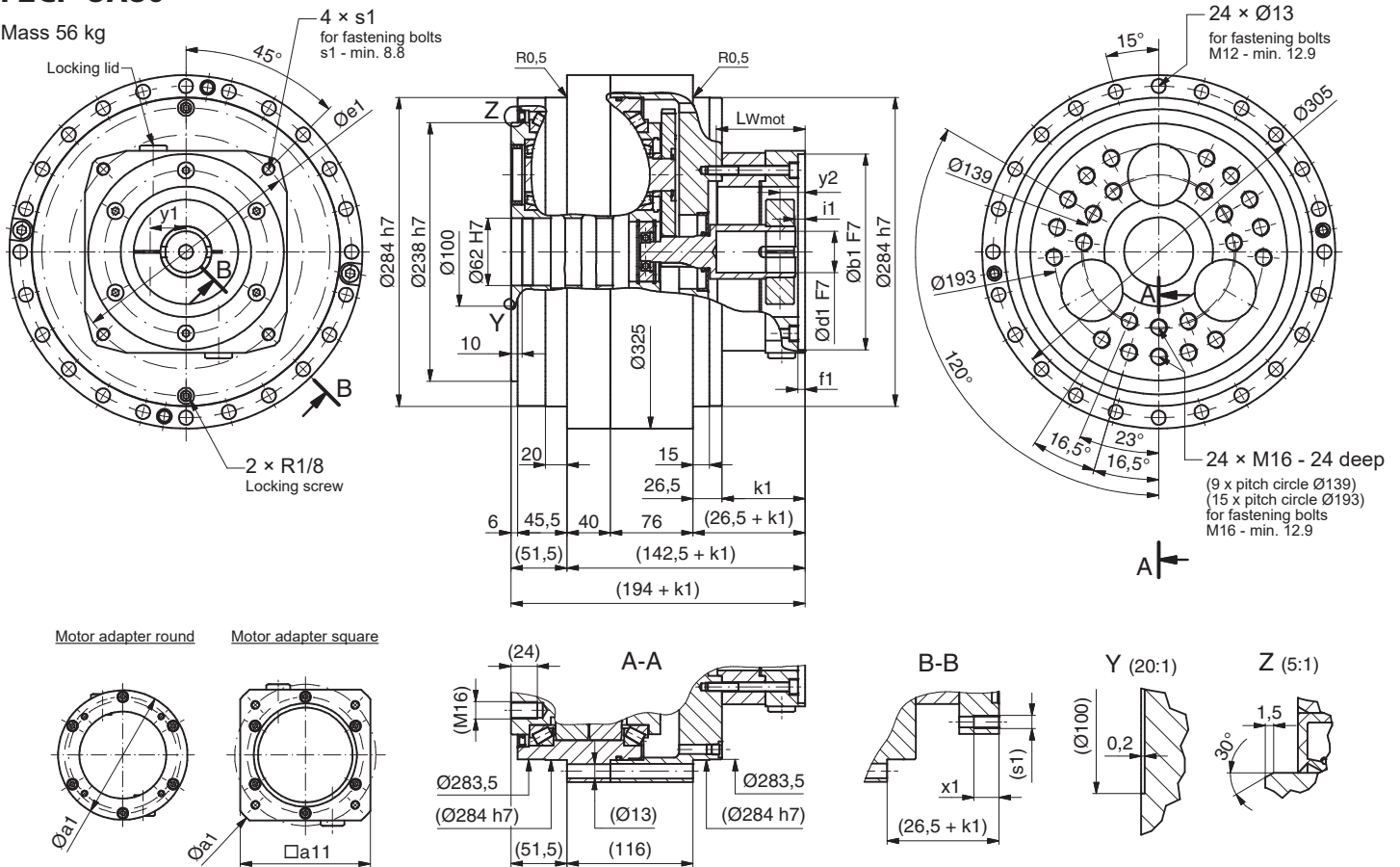

Motor mounting dimensions F2CF- UA80

Motor code	Hole for shaft Ød1	Min./Max. Length of motor shaft L _{wMot} min/max	Centering F7 Øb1	Spigot seat depth f1	Pitch circle Ø Øe1	Thread in gearbox flange 4x s1	Thread depth x1	Flange diameter Øa1	Flange square dimension □a11	Flange width k1	Shaft recess		Positional dimensions locking lid	
											i1	y1	y2	
mm														
H30G	14	29.5 / 41.0	80	6	100	M6	14	169	-	36	8.5	24	20.5	
H50G		29.5 / 41.0	110	6	130	M8	17	169	-	36	8.5	24	20.5	
H60L		41.0 / 52.5	110	6	145	M8	17	169	-	47.5	20	25	32	
J30G	16	29.5 / 41.0	80	6	100	M6	14	169	-	36	8.5	24	20.5	
J60G		29.5 / 41.0	110	6	145	M8	17	169	-	36	8.5	25	20.5	
M17G	19	30.0 / 41.5	70	9	90	M5	12	169	-	36.5	9	18.5	20	
M18G		30.0 / 41.5	70	9	90	M5	12	169	-	36.5	9	18.5	20	
M30G		29.5 / 41.0	80	6	100	M6	14	169	-	36	8.5	24	20.5	
M50G		29.5 / 41.0	110	6	130	M8	17	169	-	36	8.5	24	20.5	
M70G		29.5 / 41.0	130	8	165	M10	20	188	-	36	8.5	25	20.5	
N30G	22	29.5 / 51.0	80	6	100	M6	14	169	-	46	8.5	24	20.5	
N60G		29.5 / 51.0	110	6	145	M8	17	169	-	46	8.5	25	20.5	
N70G		29.5 / 51.0	130	8	165	M10	20	188	-	46	8.5	25	20.5	
Z30G	24	29.5 / 51.0	80	6	100	M6	14	169	-	46	8.5	24	20.5	
Z35G		29.5 / 51.0	95	6	115	M8	17	169	-	46	8.5	24	20.5	
Z50G		29.5 / 51.0	110	6	130	M8	17	169	-	46	8.5	24	20.5	
Z70G		29.5 / 51.0	130	8	165	M10	20	188	-	46	8.5	25	20.5	
Q50G	28	31.5 / 61.0	110	6	130	M8	17	169	-	56	8.5	24	20.5	
Q70G		31.5 / 61.0	130	8	165	M10	20	188	-	56	8.5	25	20.5	
Q76G		37.0 / 66.5	114.3	6	200	M12	23	223	176	61.5	14	33	26.5	
S70G	32	31.5 / 61.0	130	8	165	M10	20	188	-	56	8.5	25	20.5	
S88G		32.0 / 61.5	130	8	215	M12	23	237	186	56.5	9	30	21.5	
T76G	35	37.0 / 86.5	114.3	6	200	M12	23	223	176	81.5	14	33	26.5	
U80G	38	32.0 / 81.5	180	6.5	215	M12	23	237	168	76.5	9	30	21.5	
W87G	48	75.0 / 112.5	230	6.5	265	M12	23	297	240	107.5	40	45	58.5	
W90G		32.0 / 83.5	250	6.5	300	M16	31	337	260	78.5	11	33	22.5	

Note Other motor mounting dimensions available on request.

9 T-Series

F2C(F)-T

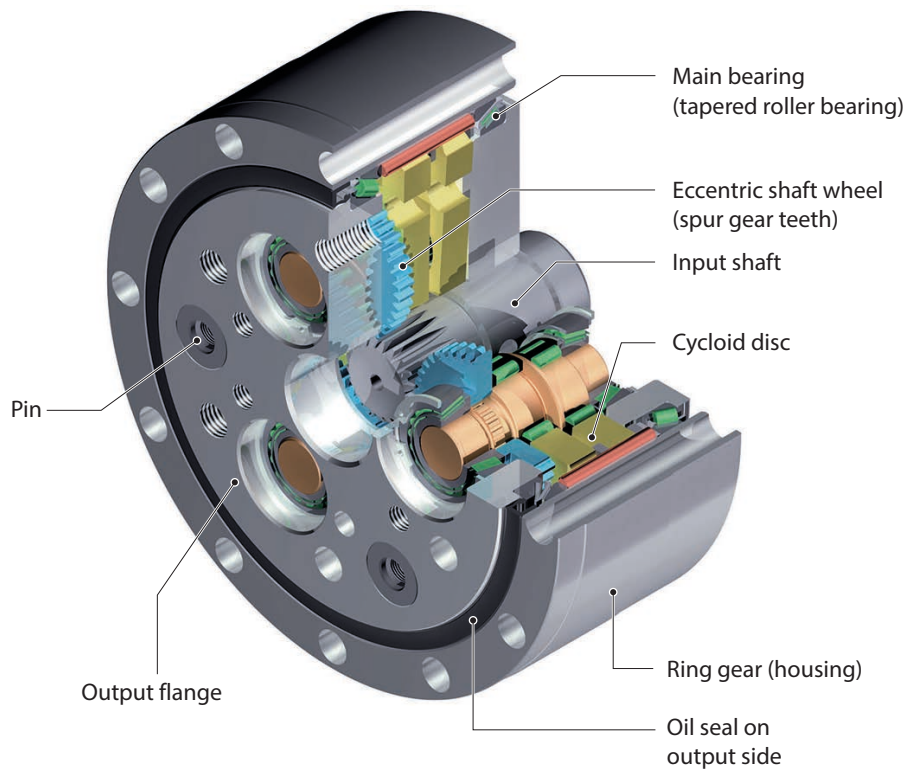

Special feature:

Gearboxes with high positioning and path accuracy, even under highly fluctuating dynamic conditions

- 7 sizes
- Integral spur gear prestage
- Low mass moments of inertia
- Reduction ratios (double-stage) 81/118.5/141/171
- Nominal output torques up to 6140 Nm
- Acceleration torques up to 11000 Nm
- Input speeds up to 8460 min⁻¹
- Lost motion < 0.5 arcmin
- Very smooth running
- High efficiency, even at low speeds
- Low vibration

Sold & Serviced By:



Toll Free Phone (877) SERV098
www.electromate.com
sales@electromate.com

9.1 Torques according to output speeds

Output speed n_{2m} [min ⁻¹]			5			10			15			20			25		
Model	Size	Reduction ratio i	Nominal output torque [Nm]	Input speed [min ⁻¹]	Max. permissible input power [kW]	Nominal output torque [Nm]	Input speed [min ⁻¹]	Max. permissible input power [kW]	Nominal output torque [Nm]	Input speed [min ⁻¹]	Max. permissible input power [kW]	Nominal output torque [Nm]	Input speed [min ⁻¹]	Max. permissible input power [kW]	Nominal output torque [Nm]	Input speed [min ⁻¹]	Max. permissible input power [kW]
F2C(F)-	T155	81	232	405	0.16	188	810	0.26	167	1215	0.35	153	1620	0.43	143	2025	0.5
		118.5	232	593	0.16	188	1185	0.26	167	1778	0.35	153	2370	0.43	143	2963	0.5
		141	232	705	0.16	188	1410	0.26	167	2115	0.35	153	2820	0.43	143	3525	0.5
	T255	81	573	405	0.4	465	810	0.65	412	1215	0.86	378	1620	1.05	353	2025	1.23
		118.5	573	593	0.4	465	1185	0.65	412	1778	0.86	378	2370	1.05	353	2963	1.23
		141	573	705	0.4	465	1410	0.65	412	2115	0.86	378	2820	1.05	353	3525	1.23
	T355	81	1091	405	0.76	886	810	1.24	785	1215	1.64	720	1620	20.1	673	2025	2.35
		118.5	1091	593	0.76	886	1185	1.24	785	1778	1.64	720	2370	20.1	673	2963	2.35
		141	1091	705	0.76	886	1410	1.24	785	2115	1.64	720	2820	20.1	673	3525	2.35
	T455	81	1770	405	1.24	1440	810	2.01	1280	1215	2.76	1170	1620	3.26	1090	2025	3.81
		118.5	1770	593	1.24	1440	1185	2.01	1280	1778	2.76	1170	2370	3.26	1090	2963	3.81
		141	1770	705	1.24	1440	1410	2.01	1280	2115	2.76	1170	2820	3.26	1090	3525	3.81
		171	1770	855	1.24	1440	1710	2.01	1280	2565	2.76	1170	3420	3.26	1090	4275	3.81
	T555	81	2730	405	1.9	2220	810	3.09	1960	1215	4.1	1800	1620	5.02	1680	2025	5.87
		118.5	2730	593	1.9	2220	1185	3.09	1960	1778	4.1	1800	2370	5.02	1680	2963	5.87
		141	2730	705	1.9	2220	1410	3.09	1960	2115	4.1	1800	2820	5.02	1680	3525	5.87
		171	2730	855	1.9	2220	1710	3.09	1960	2565	4.1	1800	3420	5.02	1680	4275	5.87
	T655	81	4360	405	3.04	3550	810	4.94	3140	1215	6.56	2880	1620	8.03	2690	2025	9.39
		118.5	4360	593	3.04	3550	1185	4.94	3140	1778	6.56	2880	2370	8.03	2690	2963	9.39
		141	4360	705	3.04	3550	1410	4.94	3140	2115	6.56	2880	2820	8.03	2690	3525	9.39
		171	4360	855	3.04	3550	1710	4.94	3140	2565	6.56	2880	3420	8.03	2690	4275	9.39
	T755	81	6140	405	4.28	4990	810	6.95	4410	1215	9.23	4050	1620	11.3	3790	2025	13.2
		118.5	6140	593	4.28	4990	1185	6.95	4410	1778	9.23	4050	2370	11.3	3790	2963	13.2
		141	6140	705	4.28	4990	1410	6.95	4410	2115	9.23	4050	2820	11.3	3790	3525	13.2
171		6140	855	4.28	4990	1710	6.95	4410	2565	9.23	4050	3420	11.3	3790	4275	13.2	

Table T-1 Rating values (reference value output speed n_{2m})

Size	Max. acceleration and deceleration torque T_{2A}	Peak torque for Emergency Stop T_{2max}
	[Nm]	[Nm]
T155	417	834
T255	1030	2060
T355	1960	3920
T455	3190	6380
T555	4910	9820
T655	7850	15700
T755	11000	22000

Table T-2 Maximum acceleration and peak torque

30			40			50			60			Max. permissible input speed $n_{1,max}$ short term [min ⁻¹]	Moment of inertia j related to the input shaft [$\times 10^{-4}$ kgm ²]	Mass [kg]
Nominal output torque [Nm]	Input speed [min ⁻¹]	Max. permissible input power [kW]	Nominal output torque [Nm]	Input speed [min ⁻¹]	Max. permissible input power [kW]	Nominal output torque [Nm]	Input speed [min ⁻¹]	Max. permissible input power [kW]	Nominal output torque [Nm]	Input speed [min ⁻¹]	Max. permissible input power [kW]			
135	2430	0.57	124	3240	0.67	116	4050	0.81	110	4860	0.92	4860	0.138	4.8
135	3555	0.57	124	4740	0.67	116	5925	0.81	110	7110	0.92	7110	0.103	
135	4230	0.57	124	5640	0.67	116	7050	0.81	110	8460	0.92	8460	0.092	
335	2430	1.40	307	3240	1.71	287	4050	2.0				4050	0.373	8.4
335	3555	1.40	307	4740	1.71	287	5925	2.0				5925	0.263	
335	4230	1.40	307	5640	1.71	287	7050	2.0				7050	0.23	
637	2430	2.67	585	3240	3.26							3240	1.05	14
637	3555	2.67	585	4740	3.26							4740	0.733	
637	4230	2.67	585	5640	3.26							5640	0.638	
1040	2430	4.33										2430	2.55	24
1040	3555	4.33										3555	1.92	
1040	4230	4.33										4230	1.72	
1040	5130	4.33										5130	1.54	
1590	2430	6.66										2430	4.98	34
1590	3555	6.66										3555	3.65	
1590	4230	6.66										4230	3.23	
1590	5130	6.66										5130	2.88	
												2025	9.65	48
												2963	7.13	
												3525	6.35	
												4275	5.68	71
												2025	16.7	
												2963	12.2	
												3525	10.8	
												4275	9.6	

- T_{2N} = nominal output torque

Nominal output torque corresponds to the max. permissible average load torque at all output speeds.
 The nominal output torque for speeds less than 5 min⁻¹ is equal to the value at 5 min⁻¹.
 The value for the maximum permissible input power is calculated from the nominal output torque at 100%.
 This value takes the efficiency of Fine Cyclo into consideration.
- $n_{1,max}$ = maximum permissible input speed

Gearbox can be used in the maximum input speed range specified in the table.
- T_{2A} = max. Acceleration and braking torque (for fatigue strength at $2 \cdot 10^7$ load cycles)

Permissible peak torque for normal start and stop procedures.
- T_{2max} = max. permissible torque for Emergency Stop situations or in the event of heavy shocks (limited by the mechanical strength).
 (permissible 1000 x over the entire lifetime)
- The rated torque T_{2N} is calculated using the following equation when the speed is not shown in the table above:

$$T_{2N} = T_{2N,15} \left(\frac{15}{n_{2m}} \right)^{0.3}$$

T_{2N} : Rated torque at output speed n_{2m}
 $T_{2N,15}$: Rated torque at output speed n_{2m} is 15 min⁻¹

9.2 Torques according to input speeds

Input speed n_{1m} [min ⁻¹]			5000			4000			3000			2500			2000			
Model	Size	Reduction ratio i	Nominal output torque [Nm]	Output speed [min ⁻¹]	Max. permissible input power [kW]	Nominal output torque [Nm]	Output speed [min ⁻¹]	Max. permissible input power [kW]	Nominal output torque [Nm]	Output speed [min ⁻¹]	Max. permissible input power [kW]	Nominal output torque [Nm]	Output speed [min ⁻¹]	Max. permissible input power [kW]	Nominal output torque [Nm]	Output speed [min ⁻¹]	Max. permissible input power [kW]	
F2C(F)-	T155	81				117	49	0.81	127	37	0.66	134	31	0.58	144	25	0.50	
		118.5	122	42	0.72	131	34	0.62	143	25	0.50	151	21	0.44	161	17	0.38	
		141	129	35	0.64	138	28	0.55	150	21	0.45	159	18	0.39	170	14	0.34	
	T255	81				288	49	1.99	314	37	1.62	332	31	1.43	355	25	1.22	
		118.5	302	42	1.78	323	34	1.52	352	25	1.24	372	21	1.10	398	17	0.94	
		141	318	35	1.58	340	28	1.35	371	21	1.10	392	18	0.97	419	14	0.83	
	T355	81								599	37	3.10	632	31	2.72	676	25	2.33
		119				615	34	2.90	671	25	2.37	709	21	2.09	758	17	1.79	
		141	606	35	3.00	648	28	2.57	707	21	2.10	747	18	1.85	798	14	1.58	
	T455	81											1031	31	4.44	1102	25	3.80
		118.5								1094	25	3.87	1156	21	3.40	1236	17	2.91
		141				1057	28	4.19	1153	21	3.42	1217	18	3.01	1302	14	2.58	
		171	1048	29	4.28	1120	23	3.66	1221	18	2.99	1290	15	2.63	1379	12	2.25	
	T555	81											1579	31	6.80	1688	25	5.82
		118.5								1675	25	5.92	1769	21	5.21	1892	17	4.46
		141				1619	28	6.41	1765	21	5.24	1864	18	4.61	1993	14	3.95	
		171	1604	29	6.55	1715	23	5.60	1870	18	4.58	1975	15	4.03	2112	12	3.45	
	T655	81														2704	25	9.32
		118.5								2684	25	9.49	2835	21	8.35	3031	17	7.14
		141								2827	21	8.40	2986	18	7.39	3193	14	6.32
		171				2748	23	8.98	2996	18	7.34	3164	15	6.46	3383	12	5.53	
	T755	81														3798	25	13.09
		118.5								3769	25	13.32	3981	21	11.73	4257	17	10.03
		141								3971	21	11.80	4194	18	10.38	4485	14	8.88
171					3860	23	12.61	4208	18	10.31	4444	15	9.07	4752	12	7.76		

Table T-3 Rating values (reference value input speed n_{1m})

Size	Max. acceleration and deceleration torque T_{2A}	Peak torque for Emergency Stop T_{2max}
	[Nm]	[Nm]
T155	417	834
T255	1030	2060
T355	1960	3920
T455	3190	6380
T555	4910	9820
T655	7850	15700
T755	11000	22000

Table T-4 Maximum acceleration and peak torque

1750			1500			1000			750			600			Max. permissible input speed $n_{1,max}$ short term [min ⁻¹]	Moment of inertia j related to the input shaft [$\times 10^{-4}$ kgm ²]	Mass [kg]
Nominal output torque [Nm]	Output speed [min ⁻¹]	Max. permissible input power [kW]	Nominal output torque [Nm]	Output speed [min ⁻¹]	Max. permissible input power [kW]	Nominal output torque [Nm]	Output speed [min ⁻¹]	Max. permissible input power [kW]	Nominal output torque [Nm]	Output speed [min ⁻¹]	Max. permissible input power [kW]	Nominal output torque [Nm]	Output speed [min ⁻¹]	Max. permissible input power [kW]			
150	22	0.45	157	19	0.41	177	12	0.31	193	9	0.25	206	7	0.21	4860	0.138	4.8
168	15	0.35	176	13	0.31	198	8	0.23	216	6	0.19	231	5	0.16	7110	0.103	
177	12	0.31	185	11	0.27	209	7	0.21	228	5	0.17	244	4	0.14	8460	0.092	
369	22	1.11	387	19	1.00	437	12	0.75	476	9	0.62	509	7	0.53	4050	0.373	8.4
414	15	0.85	434	13	0.77	490	8	0.58	534	6	0.47	571	5	0.40	5925	0.263	
436	12	0.76	457	11	0.68	516	7	0.51	562	5	0.42	601	4	0.36	7050	0.23	
704	22	2.12	737	19	1.91	832	12	1.43	907	9	1.17	970	7	1.00	3240	1.05	14
789	15	1.63	826	13	1.46	933	8	1.10	1017	6	0.90	1087	5	0.77	4740	0.733	
831	12	1.44	870	11	1.29	983	7	0.97	1071	5	0.80	1146	4	0.68	5640	0.638	
1147	22	3.46	1202	19	3.11	1357	12	2.34	1479	9	1.91	1582	7	1.64	2430	2.55	24
1286	15	2.65	1347	13	2.38	1521	8	1.79	1658	6	1.47	1773	5	1.25	3555	1.92	
1355	12	2.35	1419	11	2.11	1603	7	1.59	1747	5	1.30	1868	4	1.11	4230	1.72	
1436	10	2.05	1504	9	1.84	1698	6	1.39	1851	4	1.13	1979	4	0.97	5130	1.54	34
1757	22	5.30	1840	19	4.76	2078	12	3.58	2265	9	2.93	2422	7	2.51	2430	4.98	
1969	15	4.06	2062	13	3.65	2329	8	2.74	2539	6	2.24	2715	5	1.92	3555	3.65	
2075	12	3.60	2173	11	3.23	2454	7	2.43	2675	5	1.99	2860	4	1.70	4230	3.23	48
2198	10	3.14	2302	9	2.82	2600	6	2.12	2834	4	1.74	3031	4	1.48	5130	2.88	
2814	22	8.49	2948	19	7.62	3329	12	5.74	3629	9	4.69	3880	7	4.01	2025	9.65	
3155	15	6.51	3304	13	5.84	3731	8	4.40	4068	6	3.59	4349	5	3.07	2963	7.13	71
3324	12	5.76	3481	11	5.17	3931	7	3.89	4286	5	3.18	4582	4	2.72	3525	6.35	
3522	10	5.03	3688	9	4.52	4165	6	3.40	4541	4	2.78	4855	4	2.38	4275	5.68	
3953	22	11.92	4140	19	10.70	4675	12	8.06	5097	9	6.59	5450	7	5.64	2025	16.7	71
4431	15	9.14	4640	13	8.20	5241	8	6.17	5713	6	5.05	6109	5	4.32	2963	12.2	
4668	12	8.09	4889	11	7.26	5521	7	5.47	6019	5	4.47	6436	4	3.82	3525	10.8	
4946	10	7.07	5180	9	6.34	5850	6	4.78	6377	4	3.91	6819	4	3.34	4275	9.6	

1. T_{2N} = nominal output torque

Nominal output torque corresponds to the max. permissible average load torque at all input speeds.
The nominal output torque for speeds n_2 less than 5 min⁻¹ is equal to the value at 5 min⁻¹.
The value for the maximum permissible input power is calculated from the nominal output torque at 100%.
This value takes the efficiency of Fine Cyclo into consideration.

2. $n_{1,max}$ = maximum permissible input speed

Gearbox can be used in the maximum input speed range specified in the table.

3. T_{2A} = max. Acceleration and braking torque (for fatigue strength at $2 \cdot 10^7$ load cycles)

Permissible peak torque for normal start and stop procedures.

4. T_{2max} = max. permissible torque for Emergency Stop situations or in the event of heavy shocks (limited by the mechanical strength).
(permissible 1000 x over the entire lifetime)5. The rated torque T_{2N} is calculated using the following equation when the speed is not shown in the table above:

$$T_{2N} = T_{2N,15} \left(\frac{15}{n_{2m}} \right)^{0.3}$$

T_{2N} : Rated torque at output speed n_{2m}
 $T_{2N,15}$: Rated torque at output speed n_{2m} is 15 min⁻¹

9.3 Stiffness and Lost Motion

Size	i	Test torque T_p [Nm]	Lost Motion		Torsional stiffness 3% - 50% T_p [Nm/arcmin]	Torsional stiffness 3% - 100% T_p [Nm/arcmin]	Torsional stiffness 50% - 100% T_p [Nm/arcmin]
			Lost Motion [arcmin]	Domain of definition [Nm]			
T155	81	±167	< 0.75	±5	25	36	41
	118.5						
	141						
T255	81	±412	< 0.5	±12.4	72	103	118
	118.5						
	141						
T355	81	±785	< 0.5	±23.6	130	186	206
	118.5						
	141						
T455	81	±1280	< 0.5	±38.4	213	304	343
	118.5						
	141						
T555	81	±1960	< 0.5	±58.8	371	530	589
	118.5						
	141						
T655	81	±3140	< 0.5	±94.2	584	834	981
	118.5						
	141						
T755	81	±4410	< 0.5	±132	804	1148	1280
	118.5						
	141						
	171						

Table T-5 Torsional stiffness
 T_p : Test torque at input speed $n_i = 1500 \text{ min}^{-1}$

Note arcmin means “angular minute”.
 Table values for stiffness are average values.

Calculation of the twist angle:

1) At a load torque less than 3% T_p

$$\varphi = \frac{\text{Lost Motion}}{2} \cdot \frac{\text{Load torque}}{0.03 \cdot T_p}$$

2) At a load torque greater than 3% T_p (standard case)

$$\varphi = \frac{\text{Lost Motion}}{2} + \frac{\text{Load torque} - (0.03 \cdot T_p)}{\text{Torsional stiffness}}$$

9.4 No-load running torque NLRT

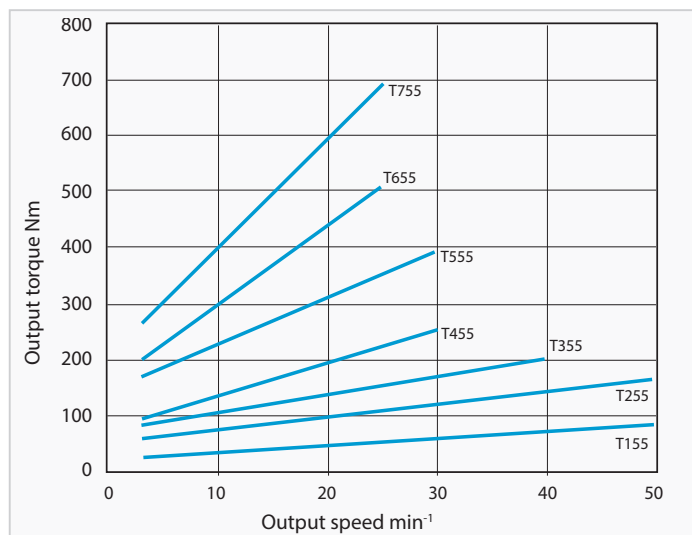

Fig. T-1 Input side no-load running torque

Note

- Fig. T-1 shows the average no-load running torque after gearbox is run in (not factory-new condition).
- Table T-6 shows the measuring conditions.

Ring gear housing temperature	approx. 30 °C
Precision during assembly	as per 9.8.1
Lubrication	Standard lubrication

Table T-6 Measurement conditions

9.5 Breakaway torque

Indicates the necessary torque for breakaway of the gearbox on the input or output side, after stop without output side load.

Breakaway torque on output side (BTO)

- Note**
1. Table T-8 shows the max. breakaway torque on the output side BTO. Fine Cyclo gearboxes are not self-locking. The BTO is defined as the maximum value (factory-new condition), which steadily decreases during the lifetime.
 2. Table T-7 shows the measuring conditions.

Precision during assembly	according to 9.8.1
Lubrication	Standard lubrication

Table T-7 Measurement conditions

Size	Breakaway torque BTO [Nm]
T155	< 40
T255	< 90
T355	< 150
T455	< 190
T555	< 270
T655	< 380
T755	< 500

Table T-8 Value of the breakaway torque on the output side (BTO)

Breakaway torque on input side (BTI)

- Note**
1. Table T-9 shows the max. breakaway torque BTI on the input side. BTI is defined as the maximum value (factory-new condition) which steadily decreases during the lifetime.
 2. Table T-7 shows the measuring conditions.

Size	i	Breakaway torque BTI [Nm]
T155	81	< 0.5
	118.5	< 0.3
	141	< 0.3
T255	81	< 1.1
	118.5	< 0.7
	141	< 0.6
T355	81	< 1.8
	118.5	< 1.2
	141	< 1
T455	81	< 2.3
	118.5	< 1.6
	141	< 1.3
	171	< 1.1
T555	81	< 3.3
	118.5	< 2.2
	141	< 1.9
	171	< 1.5
T655	81	< 4.6
	118.5	< 3.1
	141	< 2.6
	171	< 2.2
T755	81	< 6
	118.5	< 4.1
	141	< 3.5
	171	< 2.9

Table T-9 Value of the breakaway torque on the input side (BTI)

9.6 Efficiency

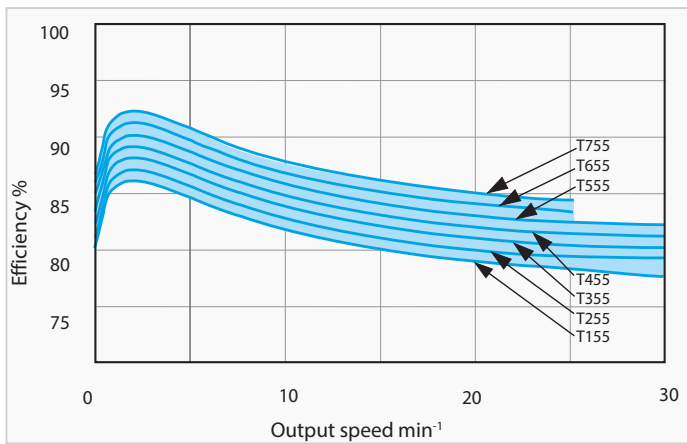

Fig. T-2a Efficiency curve

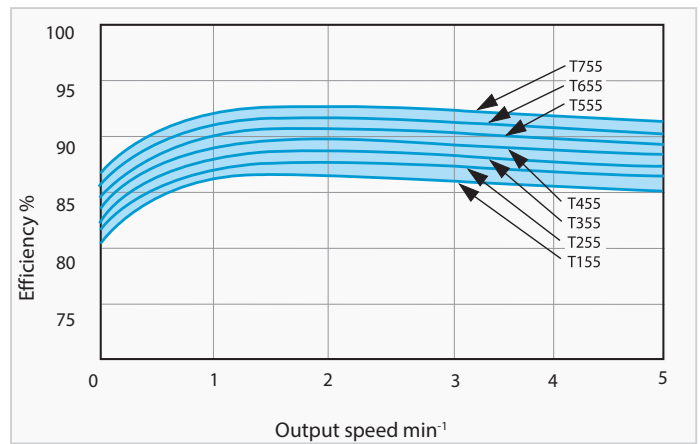

Fig. T-2b Efficiency curve at low speeds

Fig. T-2a and Fig. T-2b show the efficiency of a run-in gearbox under nominal load at an ambient temperature of 20 °C. For more information, see "4 Description of technical specifications for cycloidal gearboxes" on page 22.

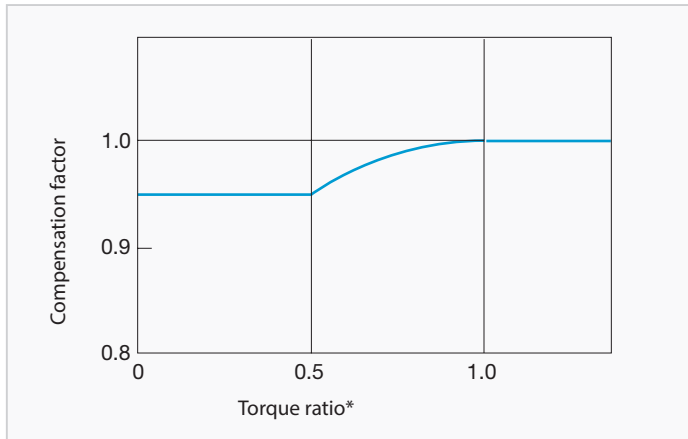

Fig. T-3 Compensation curve for efficiency

Compensation efficiency = efficiency · compensation factor

Note

1. The efficiency changes if the load torque does not match the nominal torque. Check the compensation factor in the diagram Fig. T-3.
2. When the torque ratio is over 1.0, the compensation factor for efficiency is 1.0 (diagram Fig. T-3).

$$* \text{ Torque ratio} = \frac{\text{Load torque}}{\text{Nominal output torque}}$$

Sold & Serviced By:



Toll Free Phone (877) SERV098

www.electromate.com

sales@electromate.com

9.7 Main bearing

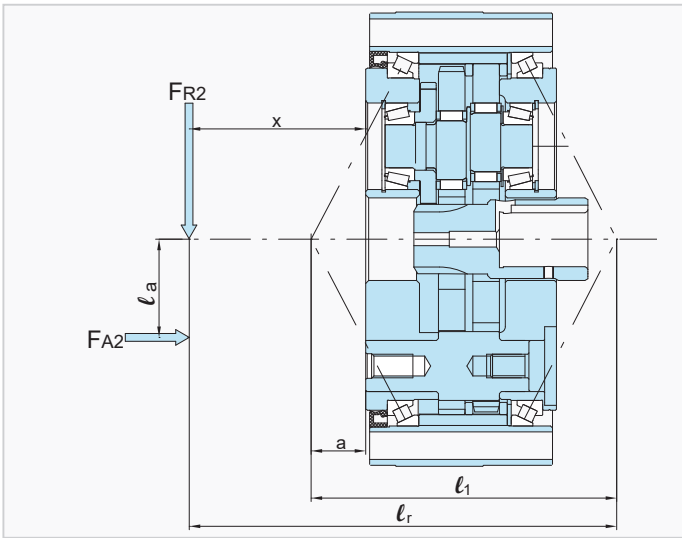

Fig. T-4 Distance between the individual loading points

$$l_r = x - a + l_1 \quad \text{(Equation T-4)}$$

1. Moment stiffness.

The moment stiffness is the bending moment at which the output flange is tilted by the tilt angle.

The tilt angle of the input flange is determined as follows:

$$\varphi_1 = \frac{T_k}{\Theta_1} \quad \text{(Equation T-5)}$$

External bending moment T_k

$$T_k = 10^{-3} \cdot (F_{R2} \cdot l_r + F_{A2} \cdot l_a) \quad \text{(Equation T-6)}$$

2. Max. permissible bending moment and max. permissible axial load.

Check the external bending moment and the external axial load using equations T-6, T-7, T-8 and Table T14.

Equivalent bending moment T_{ke}

$$T_{ke} = 10^{-3} \cdot (C_{f2} \cdot B_{f2} \cdot F_{R2} \cdot l_r + C_{f2} \cdot B_{f2} \cdot F_{A2} \cdot l_a) < T_{k \max} \quad \text{(Equation T-7)}$$

Equivalent axial load F_{A2e} at the output shaft

$$F_{A2e} = F_{A2} \cdot C_{f2} \cdot B_{f2} < F_{A2 \max} \quad \text{(Equation T-8)}$$

Size	Values of internal bearing distance	
	l_1 [mm]	a [mm]
T155	80.9	5.2
T255	92.4	5.7
T355	120.0	12.0
T455	147.2	22.6
T555	169.8	28.9
T655	205.8	39.4
T755	227.8	43.9

Table T-10 Bearing spacing dimensions [mm]

Note If: $l_r > 4 \cdot l_1$, please contact Sumitomo Drive Technologies.

Size	Moment stiffness Θ_1
	[Nm/arcmin]
T155	390
T255	835
T355	1370
T455	1860
T555	2940
T655	4420
T755	6380

Table T-11 Average values for moment stiffness

- F_{A2} = output side axial load [N]
- $F_{A2 \max}$ = maximum permissible output side axial load [N]
- F_{A2e} = equivalent output side axial load [N]
- F_{R2} = output side radial load [N]
- C_{f2} = correction factor output (Table T-12)
- B_{f2} = service factor output (Table T-13)
- l_1 = bearing clearance [mm] (Table T-10)
- l_r = calculated dimension for bending moment [mm]
- l_a = distance of axial load [mm]
- x = distance from radial force to flange collar [mm]
- a = correction factor [mm] (Table T-10)
- T_k = external bending moment [Nm]
- $T_{k \max}$ = maximum permissible bending moment [Nm] (Table T14)
- T_{ke} = equivalent bending moment [Nm]
- φ_1 = tilt angle [arcmin]
- Θ_1 = moment stiffness main bearing [Nm/arcmin] (Table T-11)

Sold & Serviced By:

 Toll Free Phone (877) SERV098
www.electromate.com
sales@electromate.com

Correction factor output	C_{f2}
Chain	1
Gear or pinion	1.25
Timing belt	1.25
V-Belt	1.5

Table T-12 Correction factor output C_{f2}

Service factor output	B_{f2}
Uniform load (no shock)	1
Light impacts	1.2
Severe impacts	1.6

Table T-13 Service factor output B_{f2}

Size	Max. permissible bending moment T_{kmax}	Max. permissible axial load F_{A2}	
		max	
	[Nm]	Tension [N]	Compression [N]
T155	883	3920	3920
T255	1180	3920	5400
T355	1820	5400	7850
T455	2750	6870	11800
T555	4170	8340	15700
T655	6380	10800	19600
T755	9570	13700	24500

Table T-14 Max. permissible bending moment and max. permissible axial load

9.8 Assembly specifications and tolerances

9.8.1 Assembly tolerances

To ensure the function, lifetime, and characteristics of the gearbox, the radial run-out of the shaft ends, the coaxiality and the axial run-out of the fastening surface as per EN 50347:2001 are sufficient. When used in high-precision applications, the tolerance according to EN 50347:2001 should be reduced by 50%, which has additional advantages.

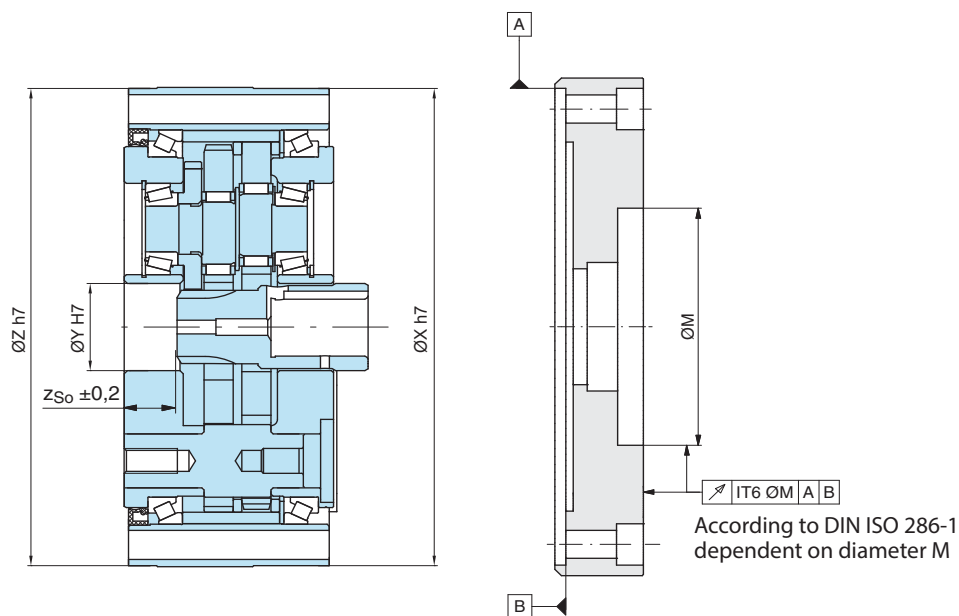

F2C-T size	Ø X	Ø Y	Ø Z	z_{So}	Ø M
155	125	23.5	125	17.5	 Motor centering
255	155	28	155	19.0	
355	185	35	185	22.5	
455	230	42	230	24.5	
555	260	47	260	27.5	
655	295	58	295	31.0	
755	330	62	330	34.5	

Table T-15 (Dimensions in mm)

F2CF-T size	Ø X	Ø Y	Ø Z	z_{So}	Ø M
155	124	23.5	124	17.5	 Motor centering
255	160	28	160	19.0	
355	190	35	190	22.5	
455	220	42	220	24.5	
555	250	47	250	27.5	
655	284	58	284	31.0	
755	328	62	328	34.5	

Tightening torque and maximum permissible transmittable torque for bolts

The permissible transmitted torque for bolts and the number, size, and tightening torque for fastening the output side flange and the ring gear housing are listed in Table T-16. In the event of an Emergency Stop with corresponding load peaks, the output flange and ring gear housing bolts must all be replaced. Liquid sealing material must be applied between all fittings of the gearbox with the customer's applications.

Size	Output flange bolts			Bolts for ring gear (housing)			
	Number and size of bolts	Pitch circle- ø	Tightening torque [Nm]	Max. permissible transmittable torque for bolts [Nm]	Number and size of bolts	Tightening torque [Nm]	Max. permissible transmittable torque for bolts [Nm]
T155	6 × M6	45	14	970	16 × M6	14	1250 (1480)*
	3 × M8	66	33				
	6 × M8	72	33				
T255	6 × M12	84	115	2160	12 × M8 (16 × M8)*	33	2150 (3500)*
	3 × M8	82	33				
	6 × M8	50	33				
T355	6 × M14	104	180	4500	16 × M8	33	3450 (4150)*
	3 × M12	102	115				
	6 × M12	63	115				
T455	6 × M16	135	280	7250	12 × M12 (16 × M10)*	115 (66)*	7350 (7650)*
	3 × M12	129	115				
	6 × M12	63	115				
T555	6 × M18	165	390	11200	16 × M12	115	11200 (14300)*
	3 × M14	150	180				
	6 × M14	115	180				
T655	6 × M22	180	750	18200	16 × M14 (16 × M12)*	180 (115)*	17300 (14300)*
	3 × M16	170	280				
	6 × M16	115	280				
T755	6 × M24	200	950	24000	16 × M16 (24 × M12)*	280 (115)*	27000 (24300)*
	3 × M18	190	390				
	6 × M18	130	390				

Table T-16

* Values in brackets apply only for type F2CF-T

- **Bolting:** Use metric hexagon socket head screws (DIN 4762, strength category 10.9).
- **Countermeasure for bolts loosening:** Use adhesives (Loctite 262, etc.) or spring washer (DIN 127A).
- **Use spring washers** (DIN 6796) when connecting the gearbox to the flange side, so that the bolt contact faces do not get damaged.

Sold & Serviced By:



Toll Free Phone (877) SERV098
www.electromate.com
sales@electromate.com

9.8.2 Installation example

(1)

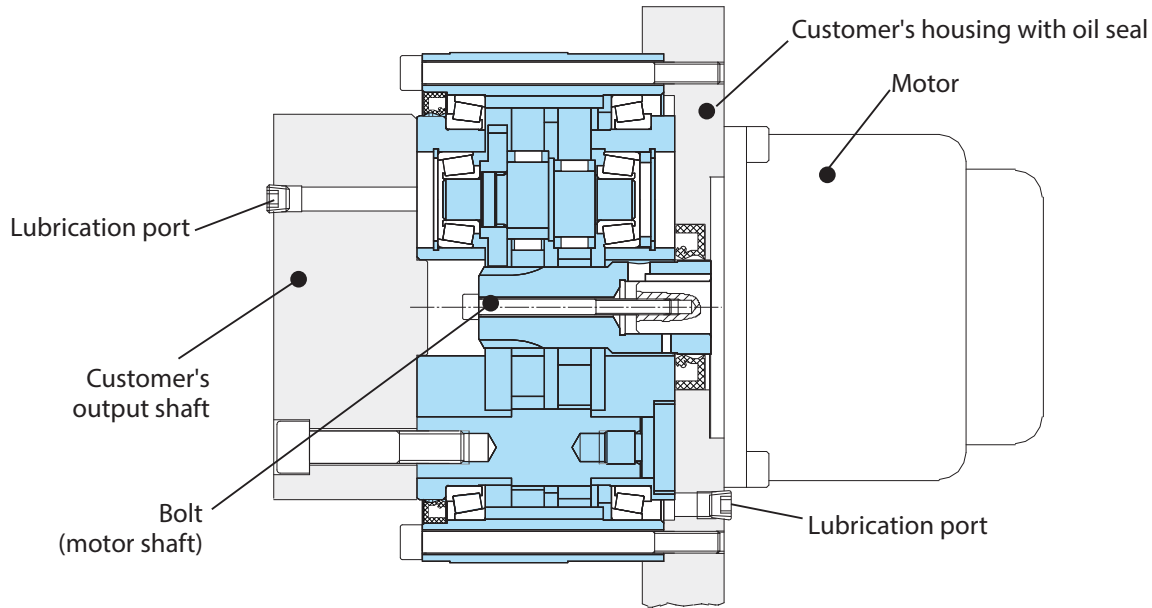

(2)

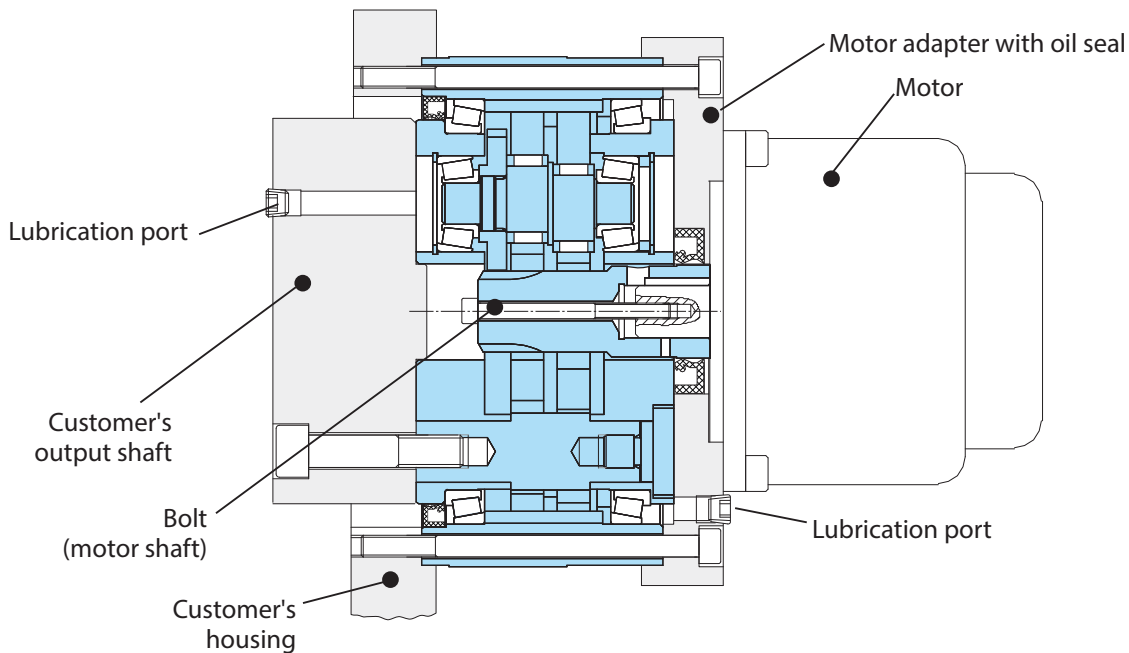

An adapter is required for the installation of the motor on the input side flange. This can be supplied. An oil seal must be provided in this adapter. The input shaft of the gearbox is not mounted in the gearbox.

The customer's output shaft is bolted to the output flange of the gearbox.

In the case of standard installations with a hollow shaft and keyway, the input shaft of the gearbox must be screwed to the front threaded hole of the motor shaft. The motor shaft must have a key. The correct insertion depth of the gearing (shaft distance from output) must be observed as per the Fine Cyclo catalogue (see the dimension sheets).

9.8.3 Lubrication

- F2C(F)-T Fine Cyclo gearboxes are delivered without grease and must be filled with Multemp FZ No.00 grease as per Table T-178 and sealed before being used for the first time (for the grease filling port, see Figure). These greases are suitable for ambient temperatures from -10 °C to +40 °C.
- Reconditioning is recommended after 20,000 operating hours, but at least every 3-5 years.

Size	Quantity of grease [g]		A [mm]
	Vertical	Horizontal	
T155	80	60	25
T255	120	100	31
T355	230	180	39
T455	300	240	47
T555	400	320	55
T655	700	560	63
T755	800	640	73

Table T-18 Lubrication

The grease quantity above relates to the gearbox. The cavity between the gearbox and the motor (intermediate flange) must also be taken into account.

Specified grease	Manufacturer
Multemp FZ No. 00	Kyodo Yushi Co., Ltd.
Conditions for use: Ambient temperature -10 °C to +40 °C	

Table T-17 Specified grease for the T Series

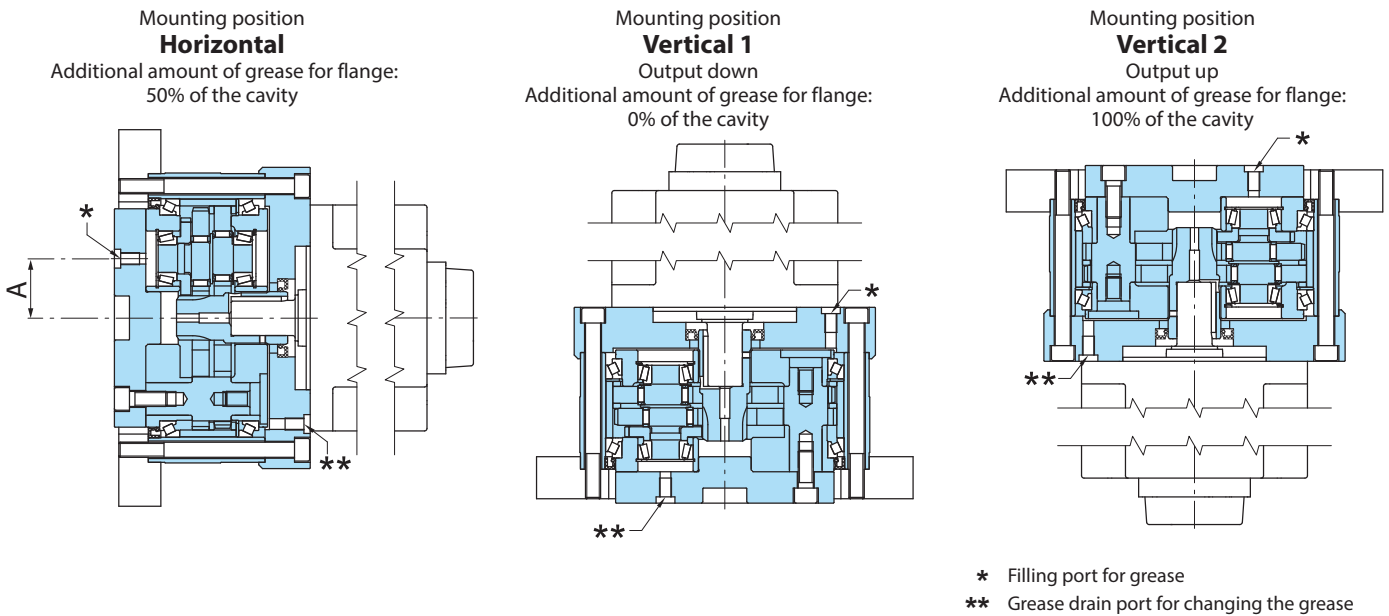

Determination of the cavity

The additional amount of grease is necessary for the functioning of the gearbox.

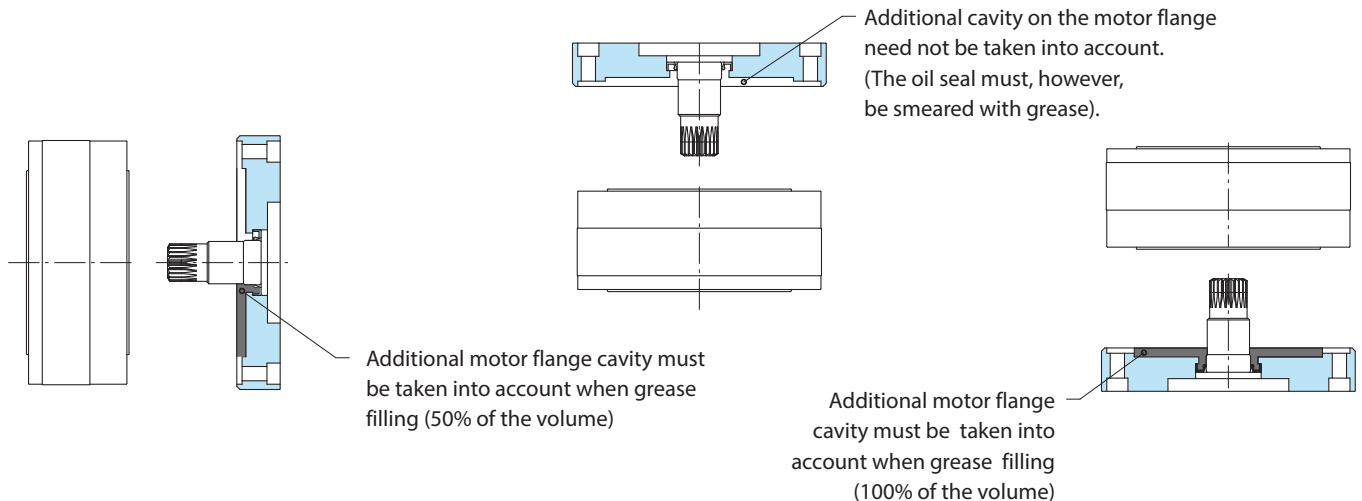

9.9 Dimensioned drawings

F2C-T155

Mass 4.8 kg

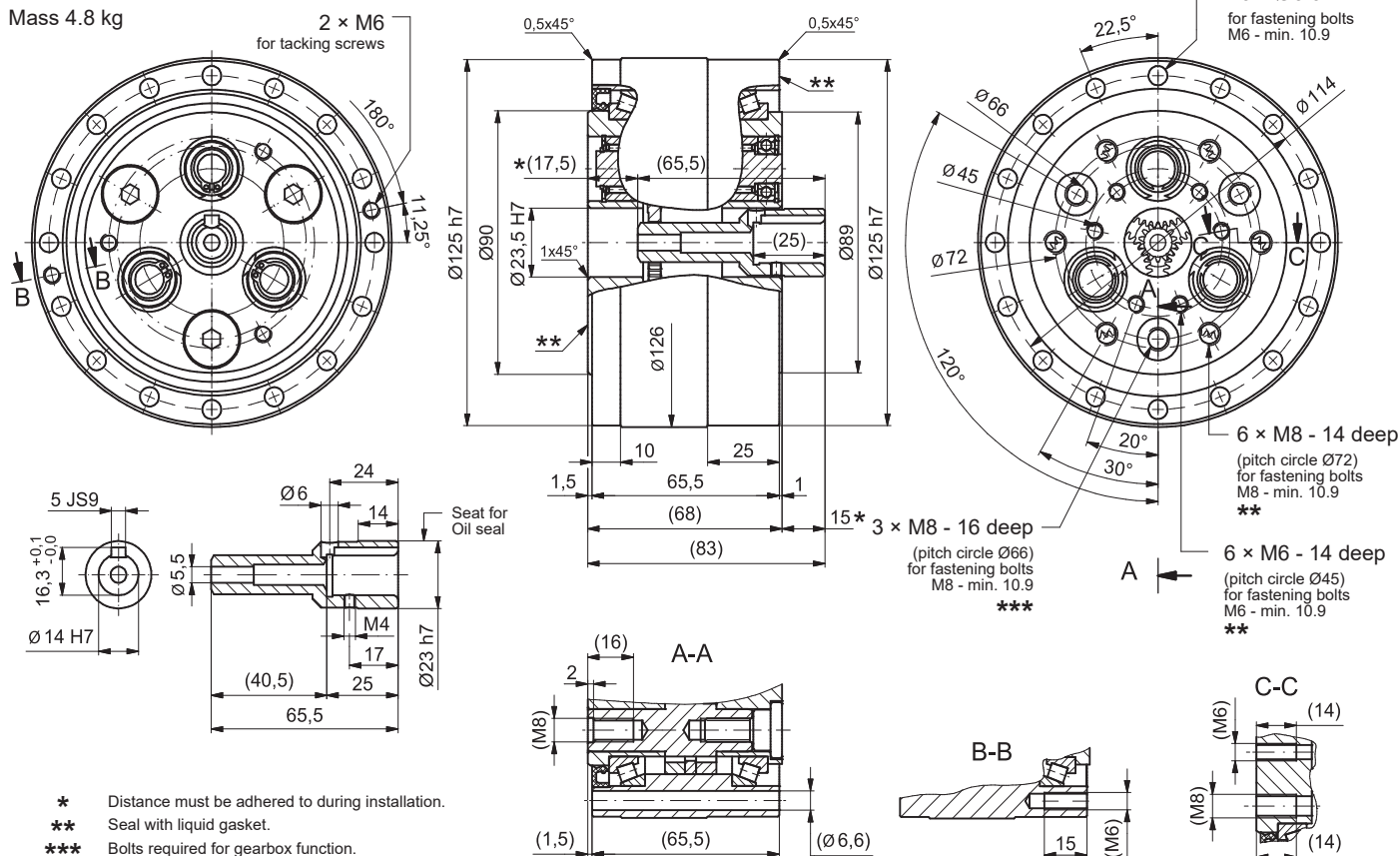

F2CF-T155

Mass 5 kg

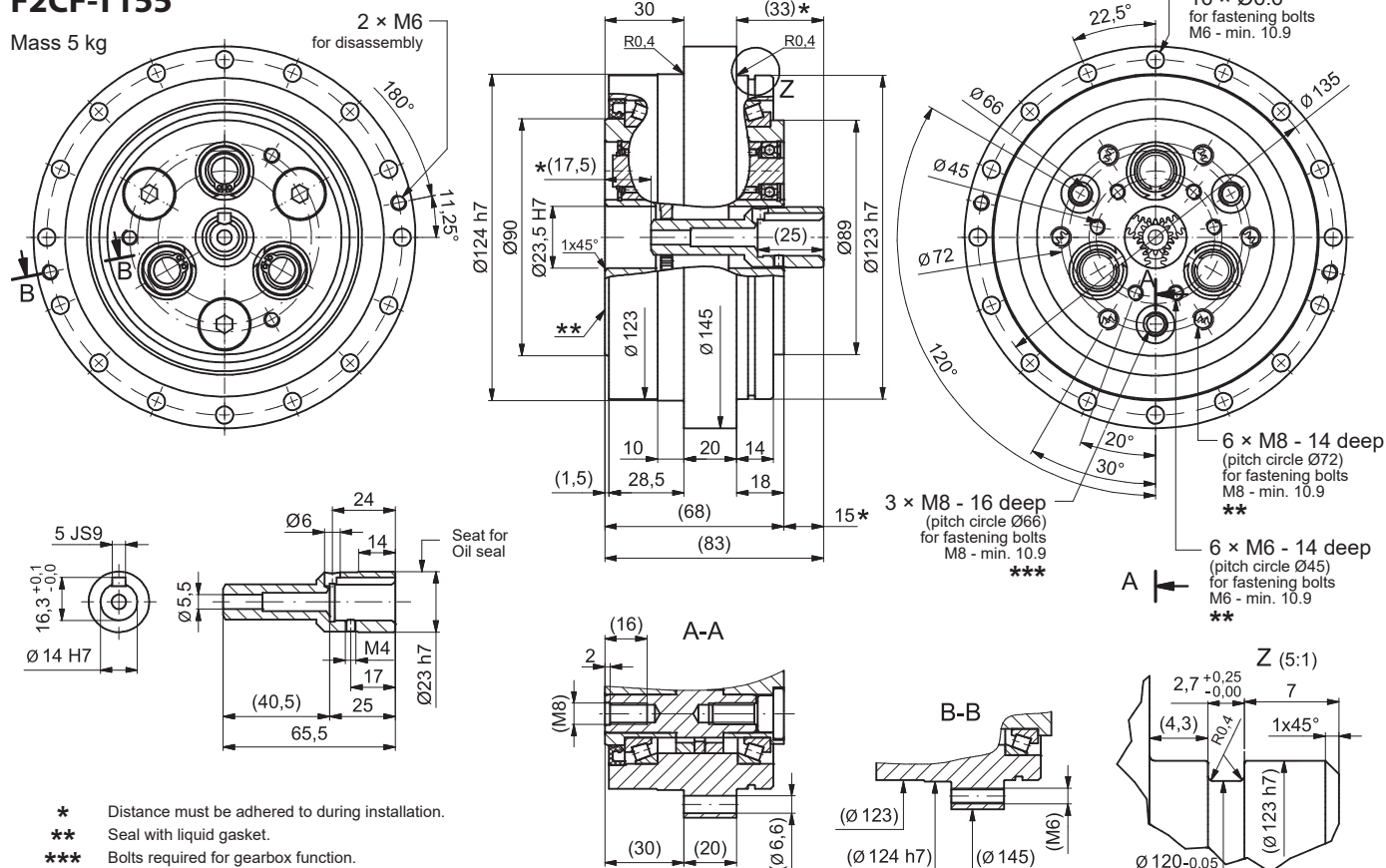

F2C-T255

Mass 8.4 kg

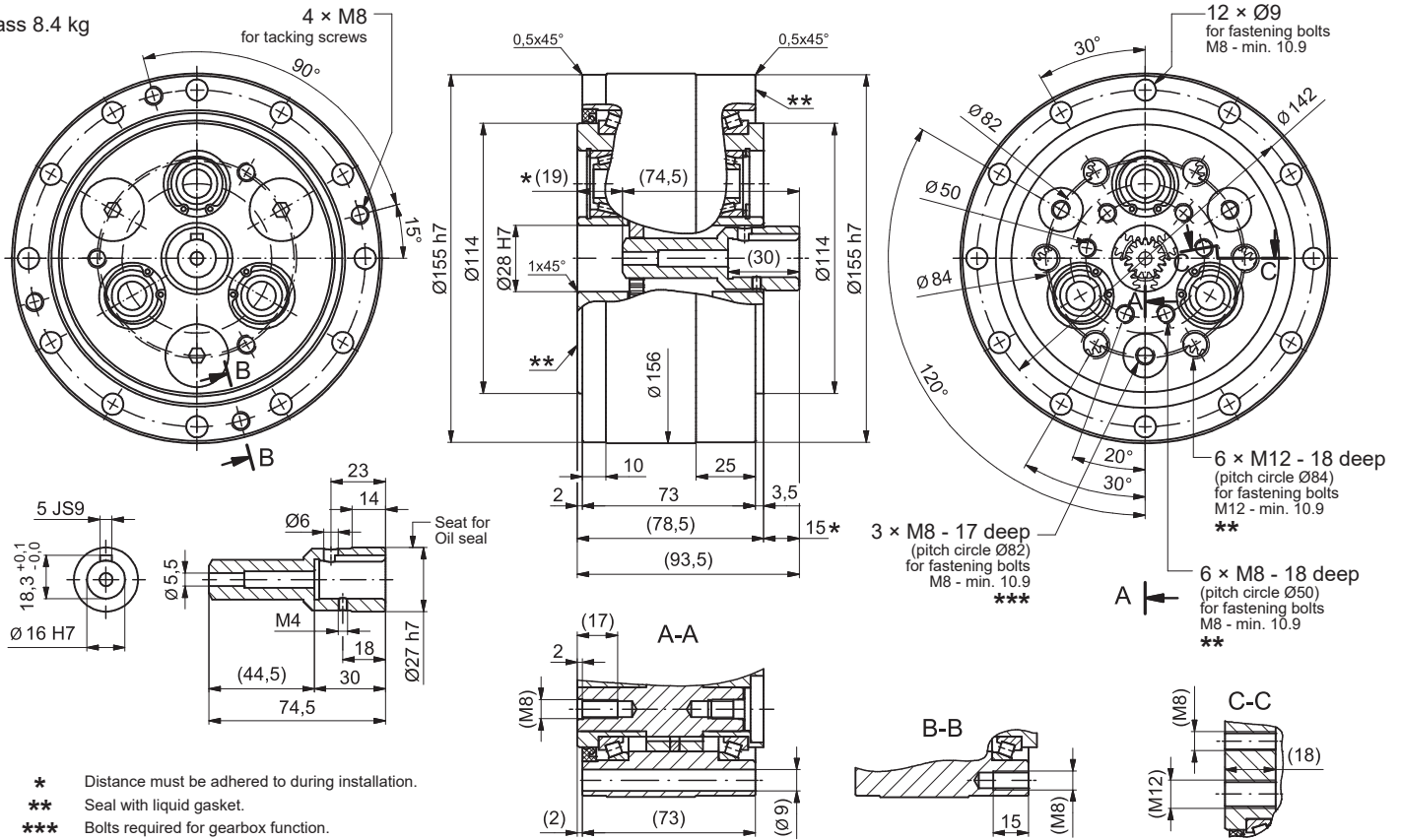

F2CF-T255

Mass 10 kg

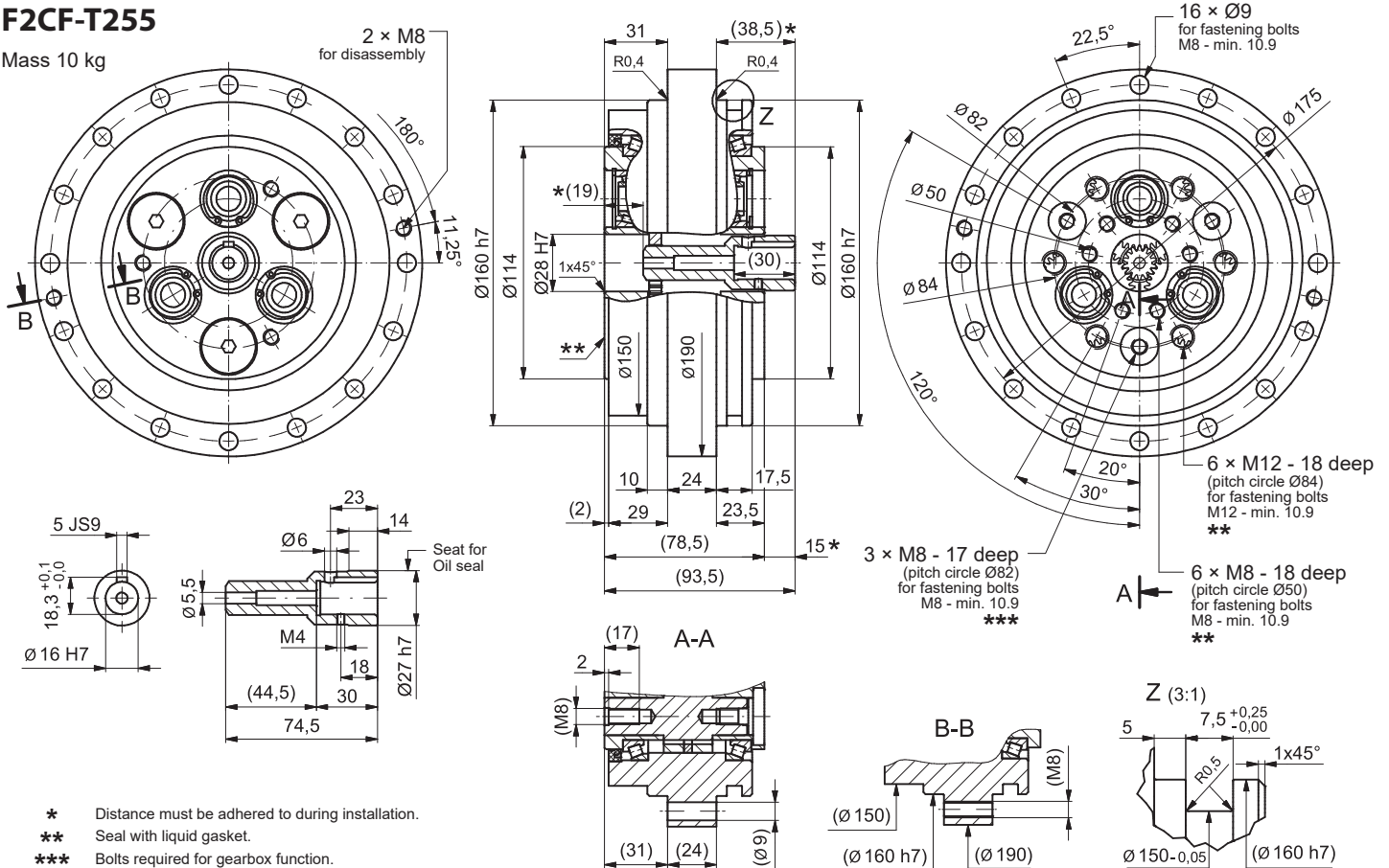

F2C-T355

Mass 14 kg

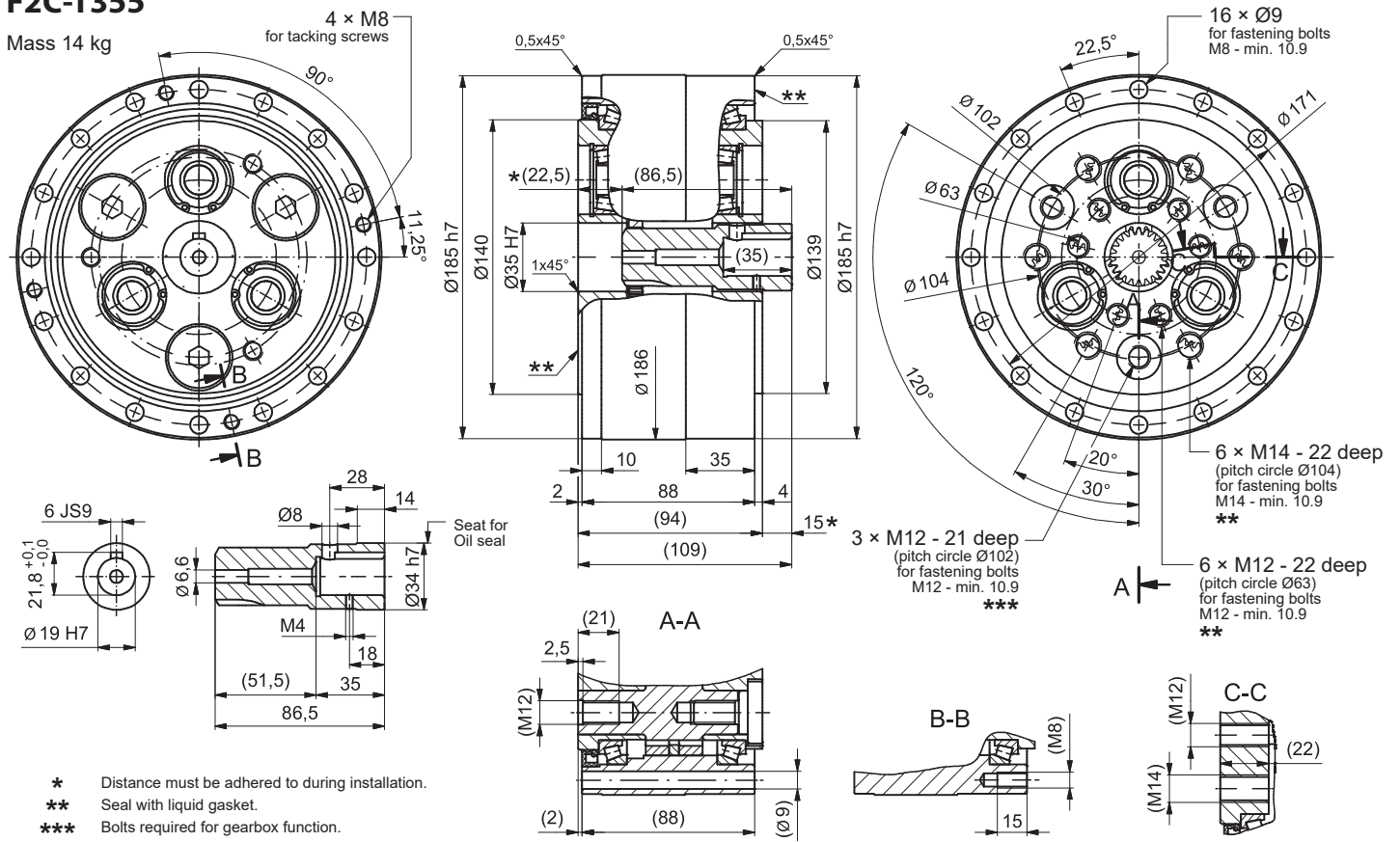

F2CF-T355

Mass 15 kg

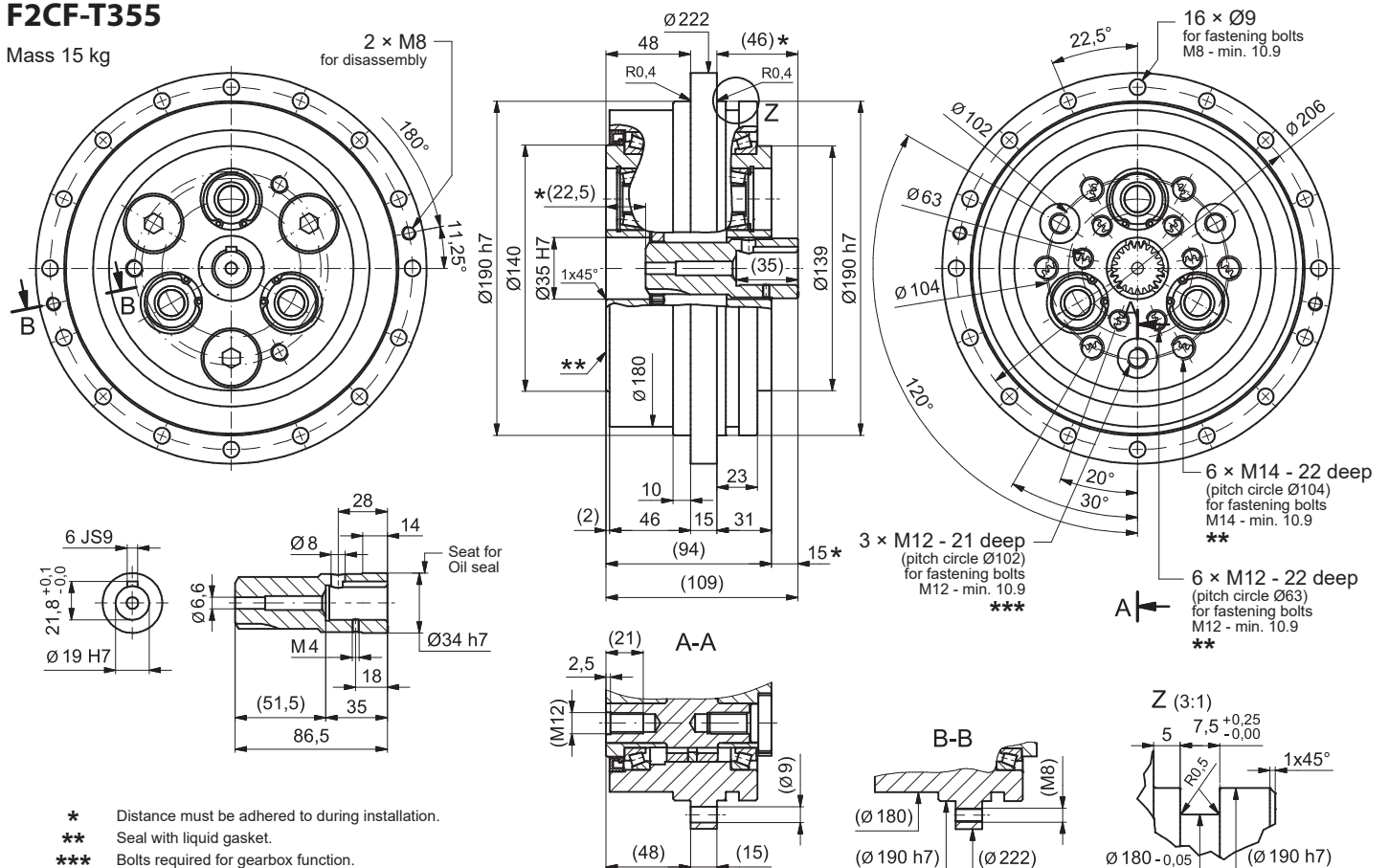

F2C-T455

Mass 24 kg

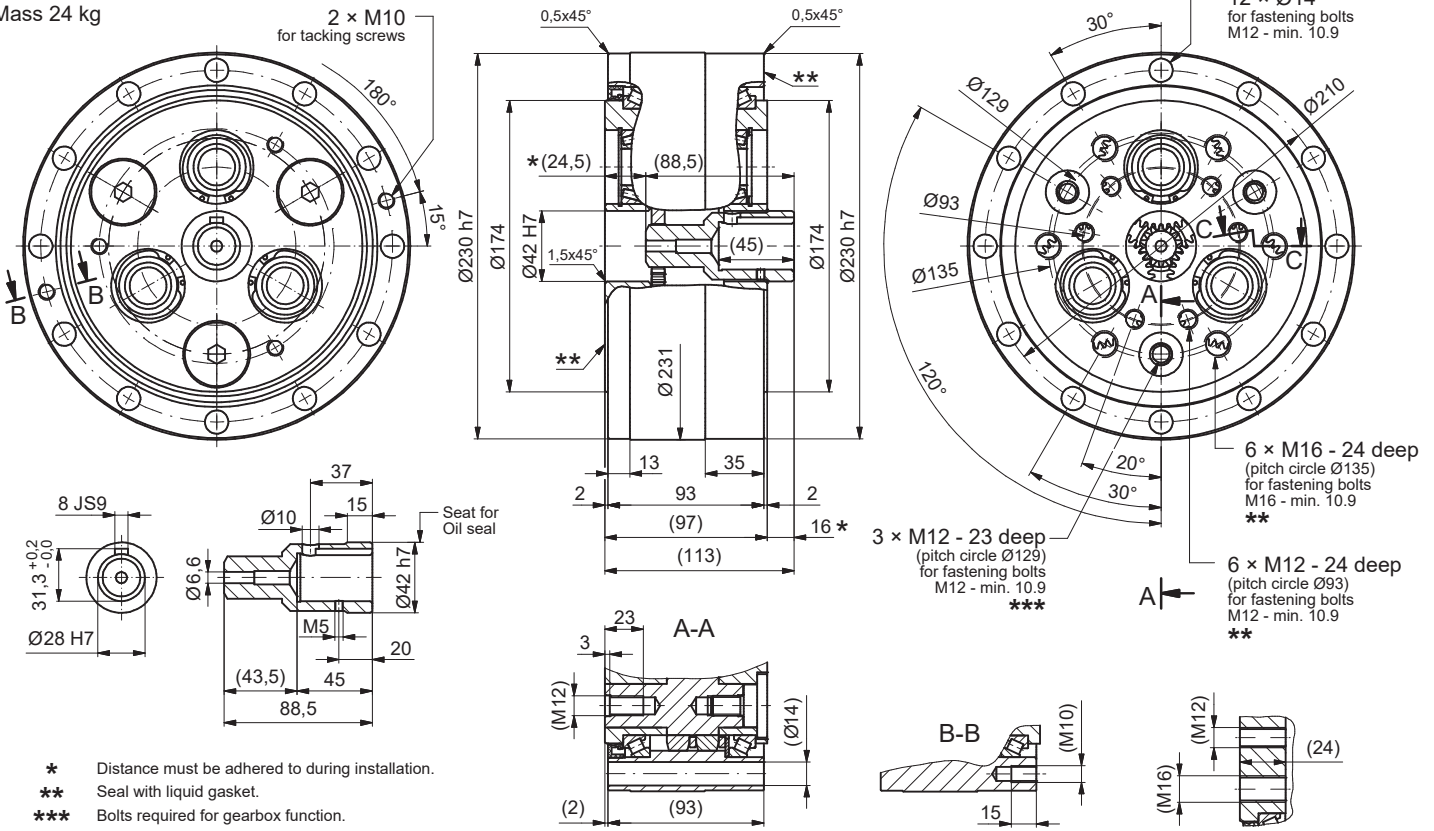

- * Distance must be adhered to during installation.
- ** Seal with liquid gasket.
- *** Bolts required for gearbox function.

F2CF-T455

Mass 24 kg

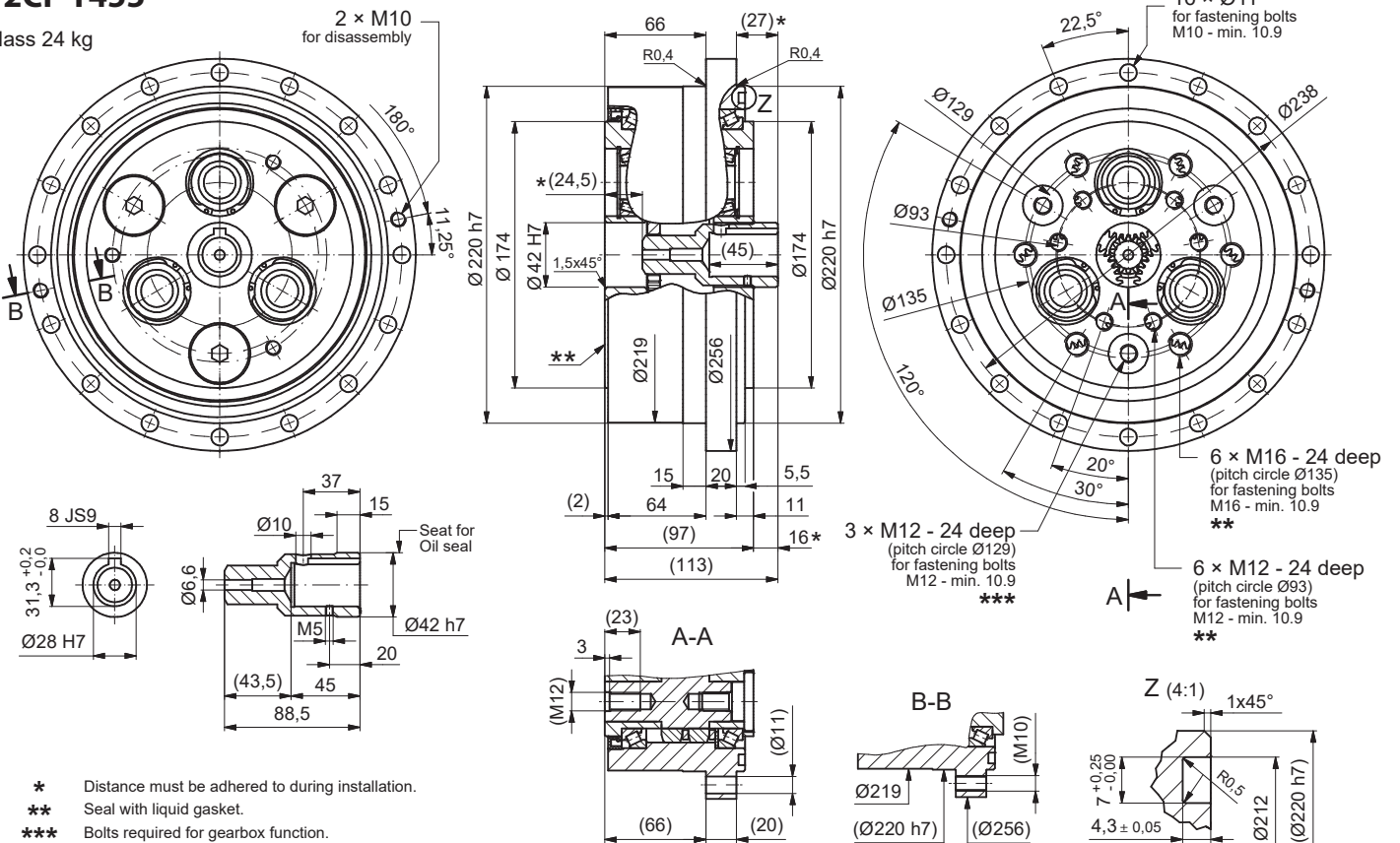

- * Distance must be adhered to during installation.
- ** Seal with liquid gasket.
- *** Bolts required for gearbox function.

F2C-T655

Mass 48 kg

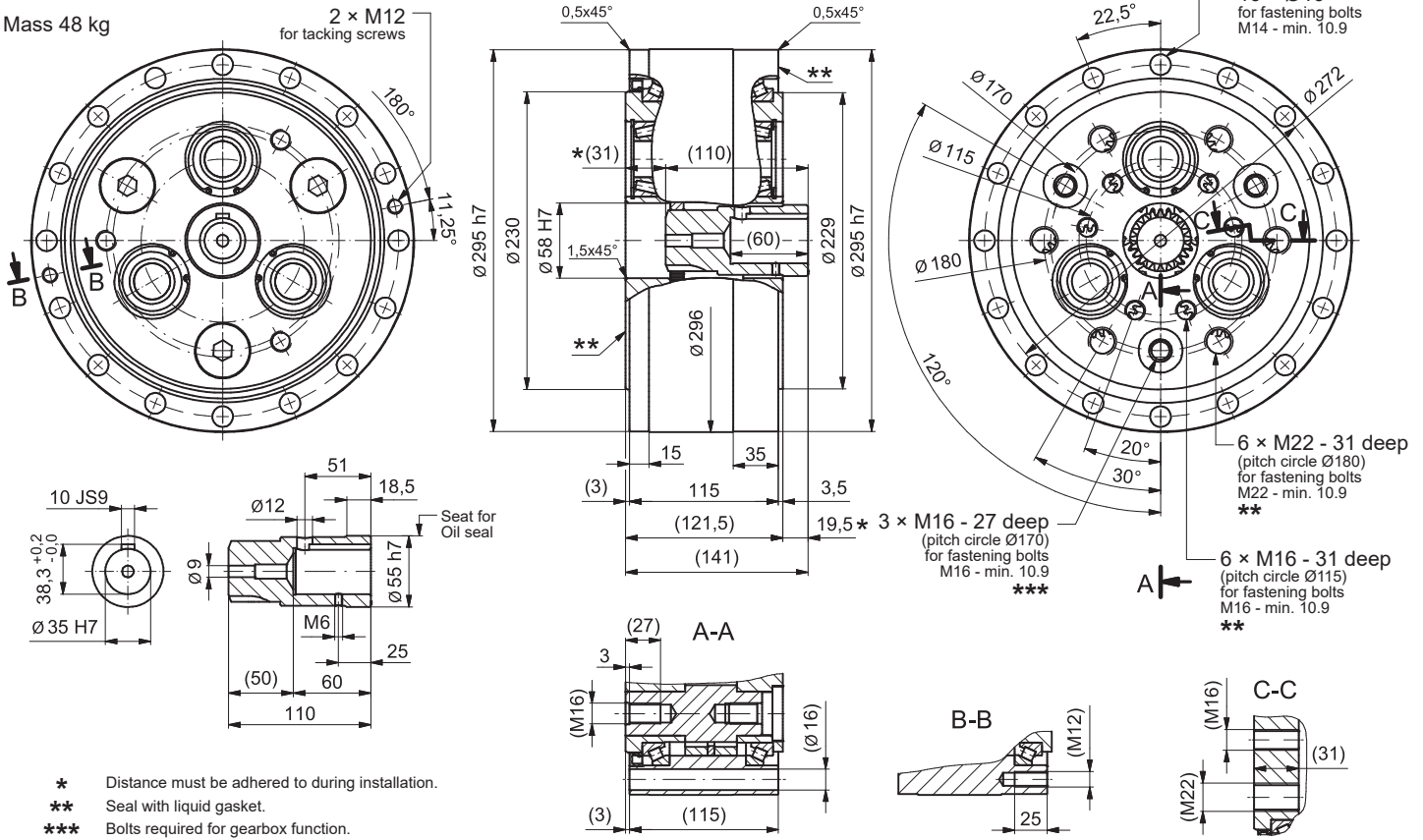

- * Distance must be adhered to during installation.
- ** Seal with liquid gasket.
- *** Bolts required for gearbox function.

F2CF-T655

Mass 50 kg

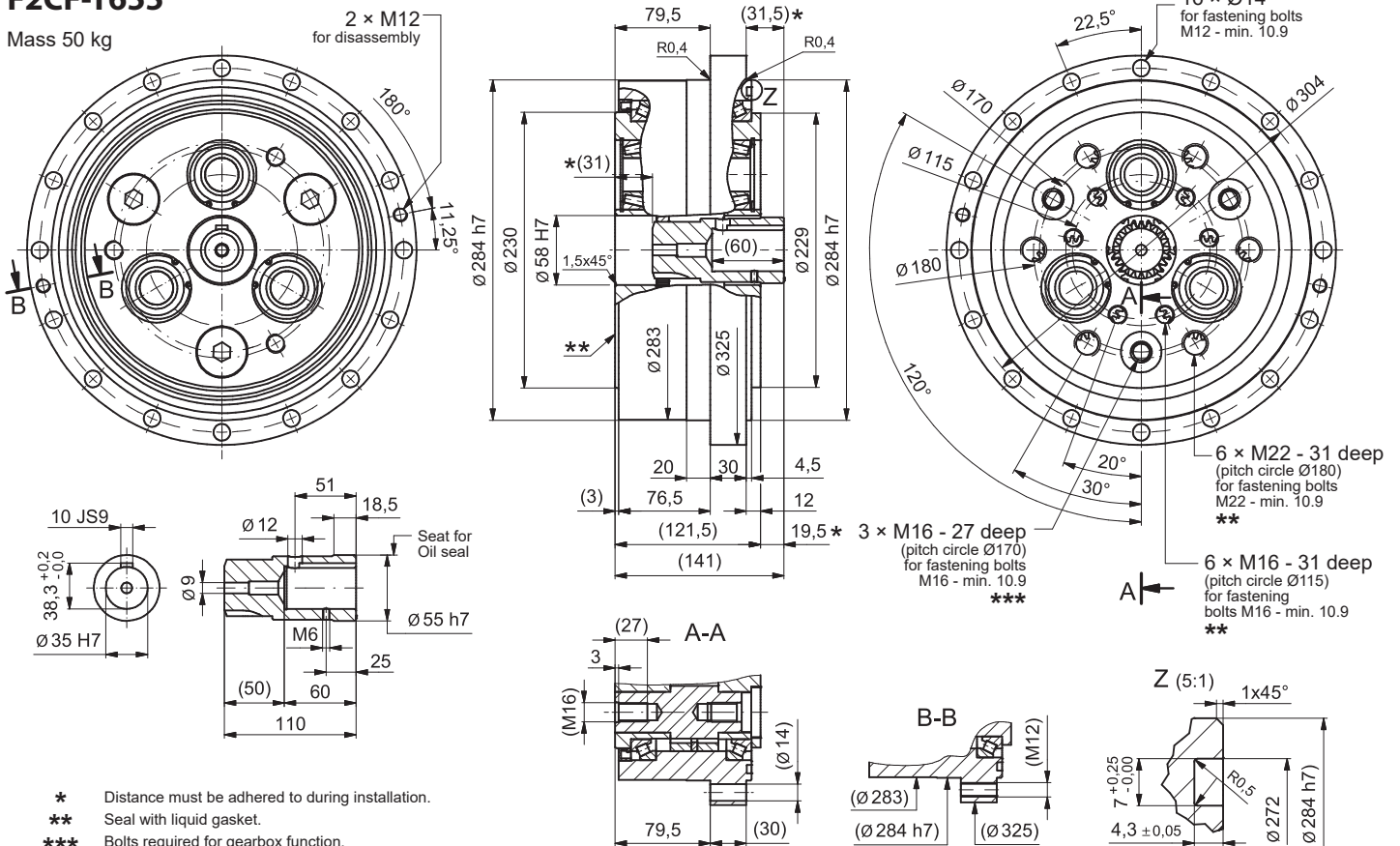

- * Distance must be adhered to during installation.
- ** Seal with liquid gasket.
- *** Bolts required for gearbox function.

F2C-T755

Mass 71 kg

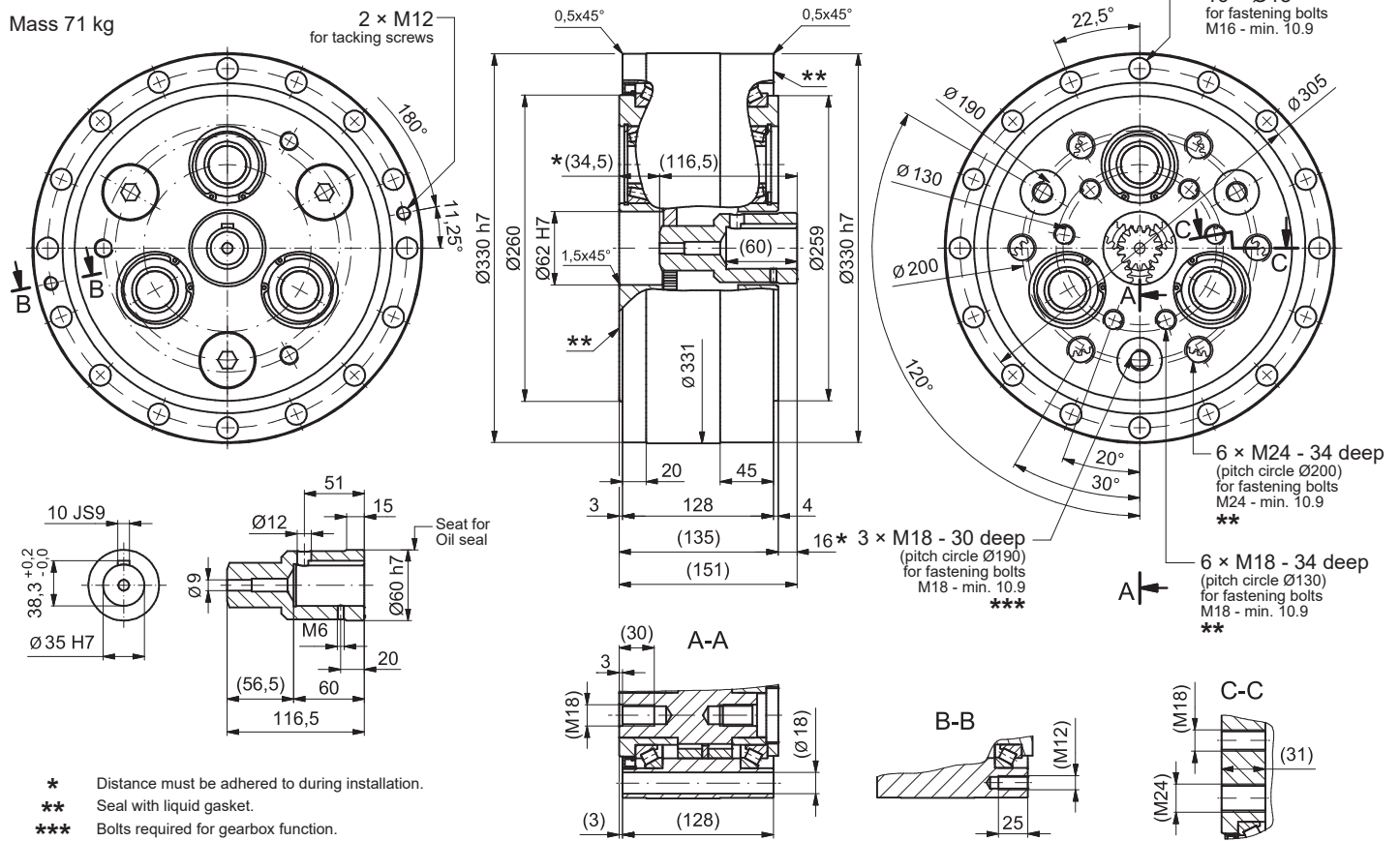

F2CF-T755

Mass 76 kg

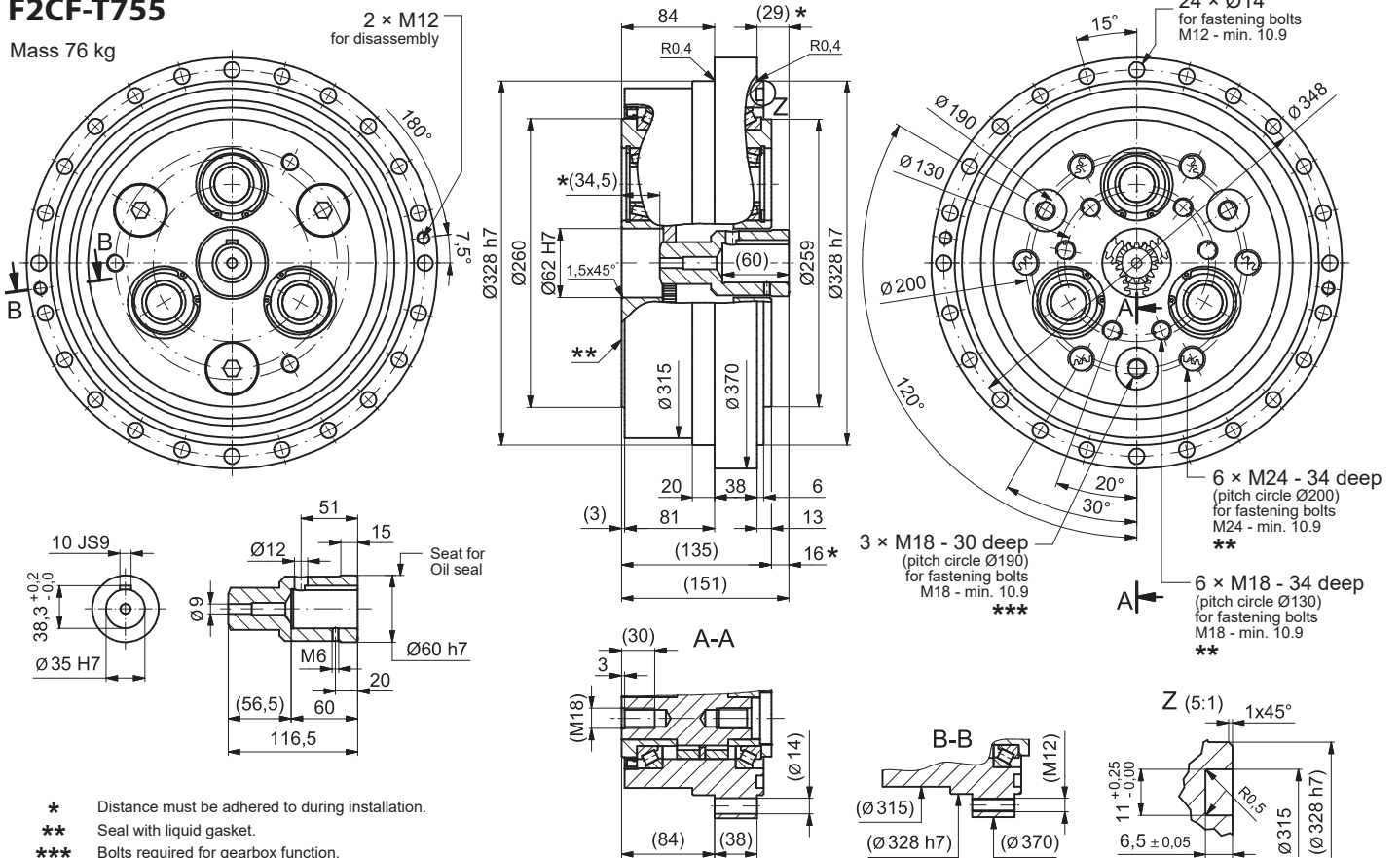

10 ECY-Series

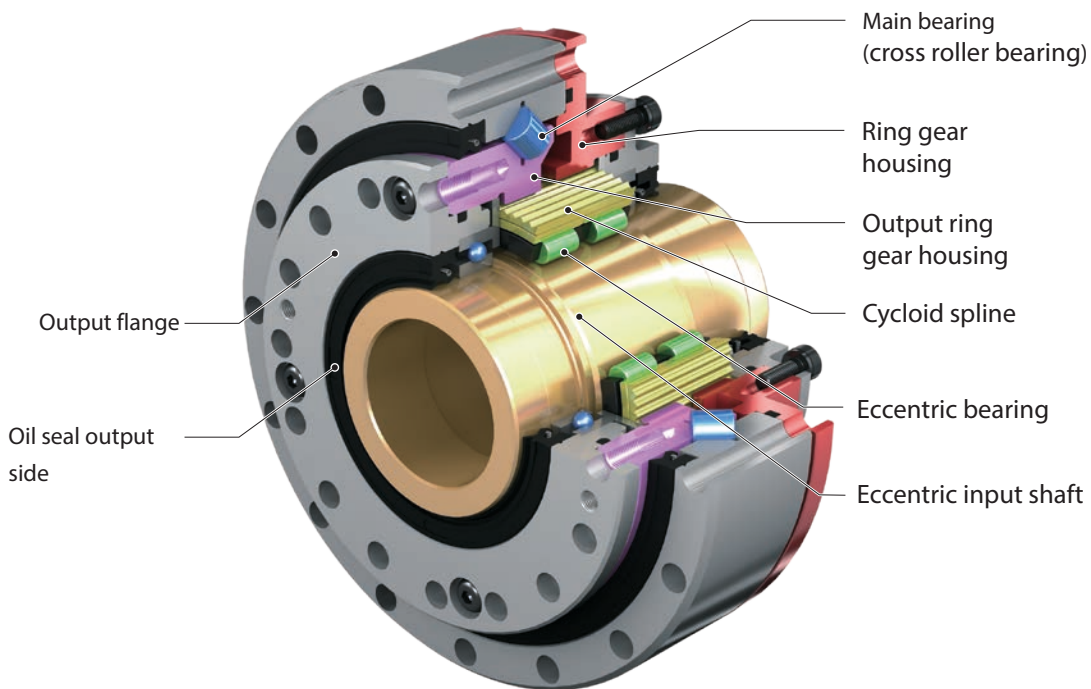

Special feature:

Complete set with cross roller bearing and hollow shafts for effective use of space for cable or media, up to $\varnothing 25.5\text{mm}$

- High stiffness
- Lost motion 1.0 arcmin
- Transmission error 0.75 arcmin
- Maximum input speed 8,500 rpm
- Permissible torques up to 219 Nm
- Radial loads up to 2,050 N
- Axial loads up to 3,000 N
- Completely sealed, including main cross roller bearing

Sold & Serviced By:

 **ELECTROMATE**

Toll Free Phone (877) SERV098
www.electromate.com
sales@electromate.com

10.1 Standard specifications

Lubrication	Grease lubrication Product filled with grease in factory prior to delivery. See "10.11.4 Lubrication" for more details.
Ambient conditions	Ambient temperature of -10 to +40 °C (starting problems may occur depending on the rotation speed and the torque of the motor being used. If you need to use the gearbox at temperatures of -10 to 0 °C, please contact us).
Humidity	85 % or less. No condensation.
Altitude	1000 m or lower
Ambient air	- Free of corrosive or volatile gases and vapours. - Dust-free, well-ventilated area.
Installation location	- Indoors (free of dust, water and other fluids). - If installation under different conditions is necessary, special requirements must be met. In this case, please contact us. - Installation in a location that allows easy operation, inspection and maintenance. - Installation on a sufficiently rigid supporting element.
Installation direction	Any installation direction can be selected.
Painted finish	Colourless (no paint) * The packaging material used provides good rust protection, but additional rust protection must be provided for parts that have been unpacked or scheduled for long-term storage.

10.2 Features

Compact at high torque

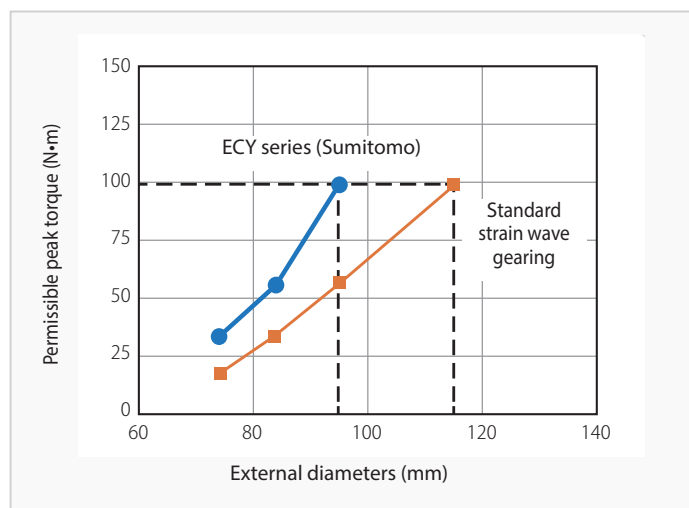

The permissible peak torque is approximately 1.5 times higher than that of a standard stress wave gear (same size), which means that the gearbox can be more compact.

High stiffness

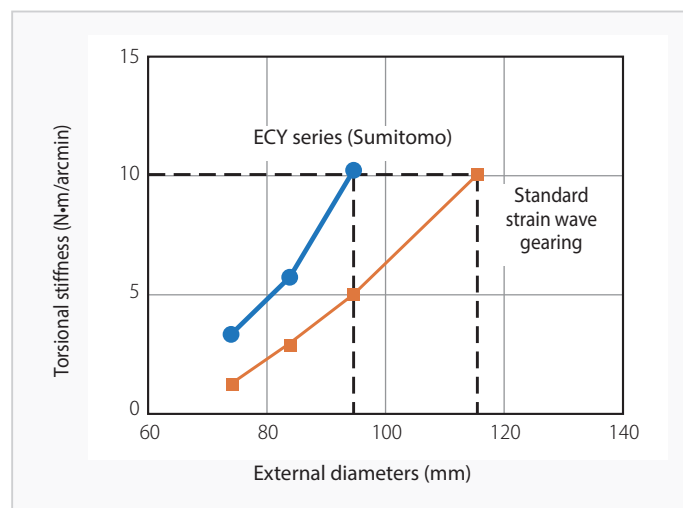

The torsional stiffness is approximately twice that of a standard strain wave gear (same size), which results in a stronger unit with considerably reduced vibration.

Sold & Serviced By:



Toll Free Phone (877) SERV098

www.electromate.com

sales@electromate.com

Ratcheting resistance (safety in the event of an overload)

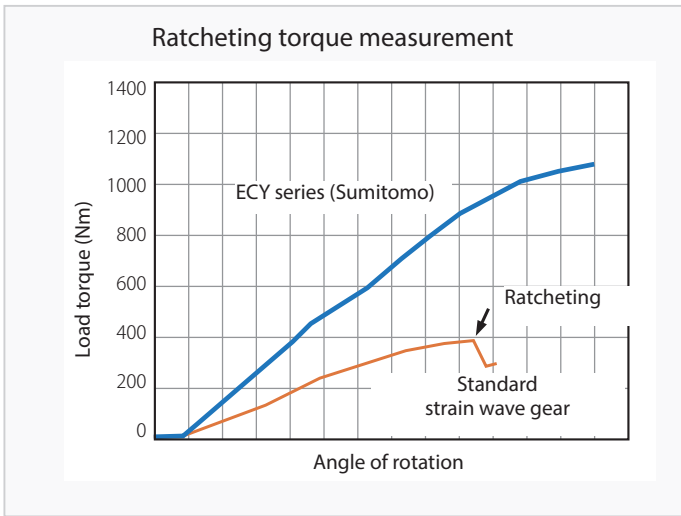

Ratcheting rarely occurs, which ensures a high degree of overload safety.

Reasons for above-average strength

	Examples of standard strain shaft gear	ECY Series
External gear profile	Cup type / hat type	Cylinder type
Tooth contact in the tooth trace direction	30 - 50 %	100 %
Elliptical bearing structure	Ball bearing	Roller bearing

The structure differs from a standard strain shaft gear and provides high strength.

Large diameter of hollow input shaft

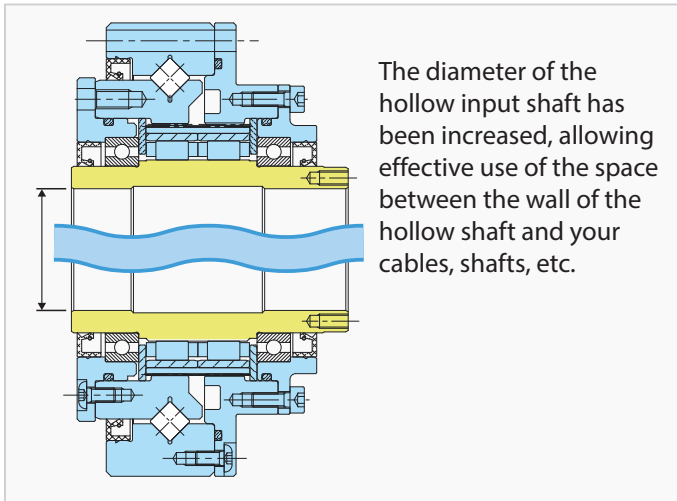

Reduction of assembly work performed by the user

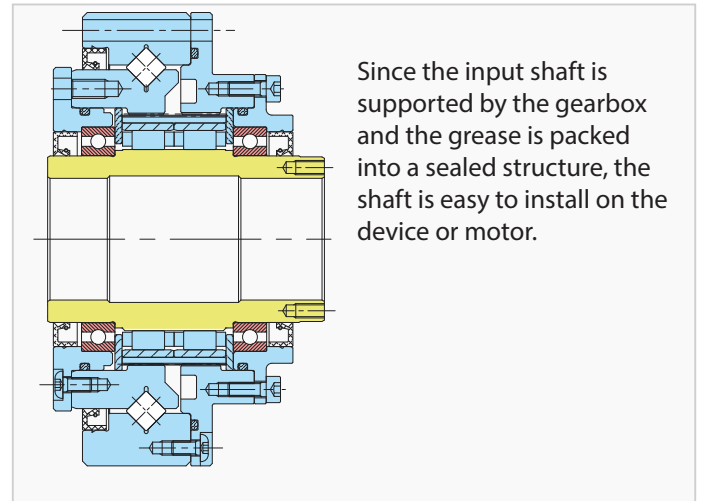

Sold & Serviced By:

 Toll Free Phone (877) SERV098
www.electromate.com
sales@electromate.com

10.3 Flow chart and equation of selection

Load pattern

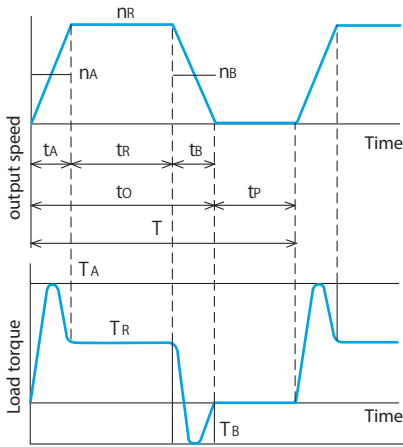

n_A : Average output speed during acceleration
 In the case of the above figure $n_A = \frac{n_R}{2}$
 n_R : Output speed during normal operation
 n_B : Average output speed during deceleration
 In the case of the above figure $n_B = \frac{n_R}{2}$
 t_A : Acceleration time
 t_R : Normal running time
 t_B : Braking time
 t_o : Total running time
 t_p : Idle time
 T : Cycle time
 T_A : Peak acceleration torque
 T_R : Normal running torque
 T_B : Peak brake torque

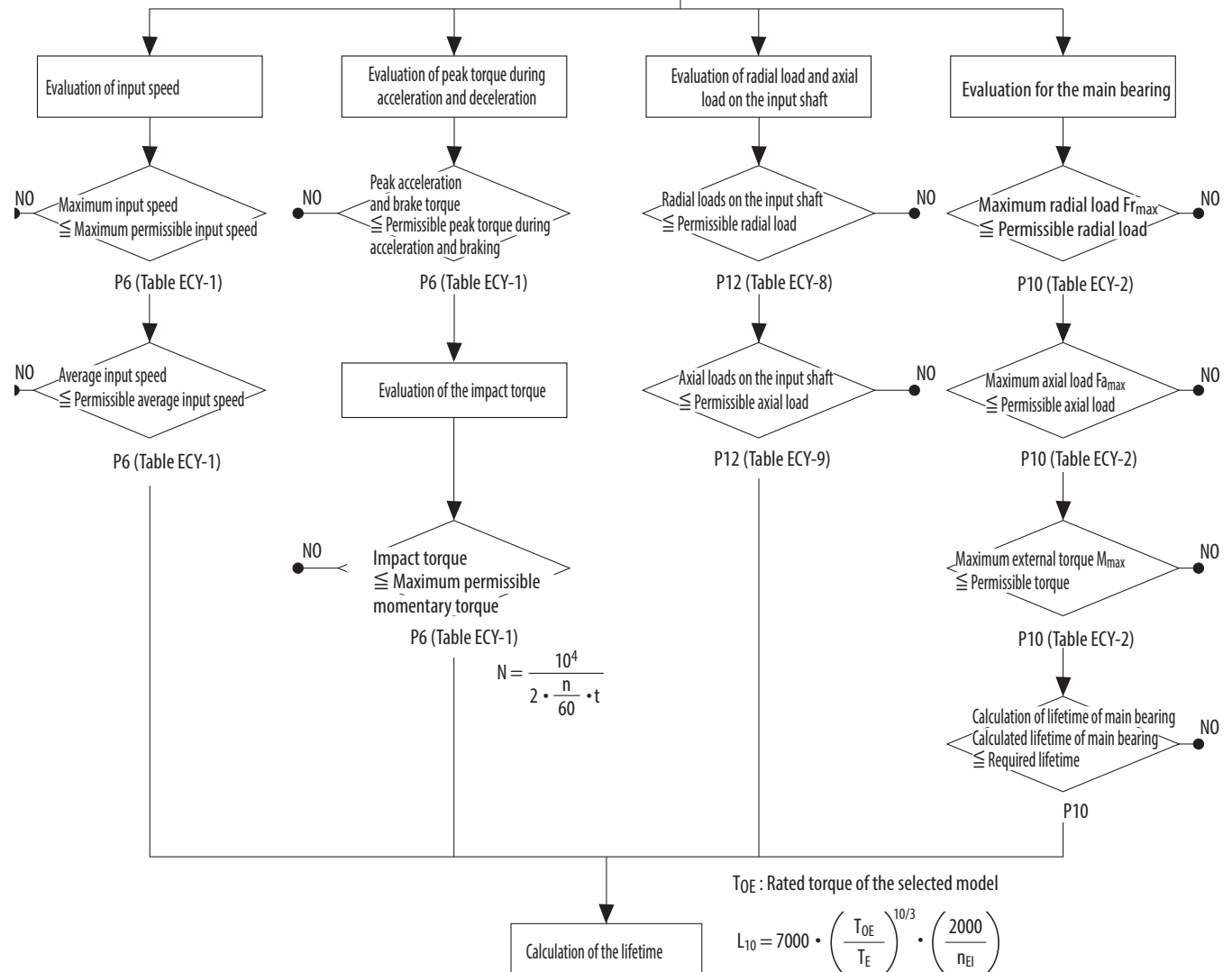
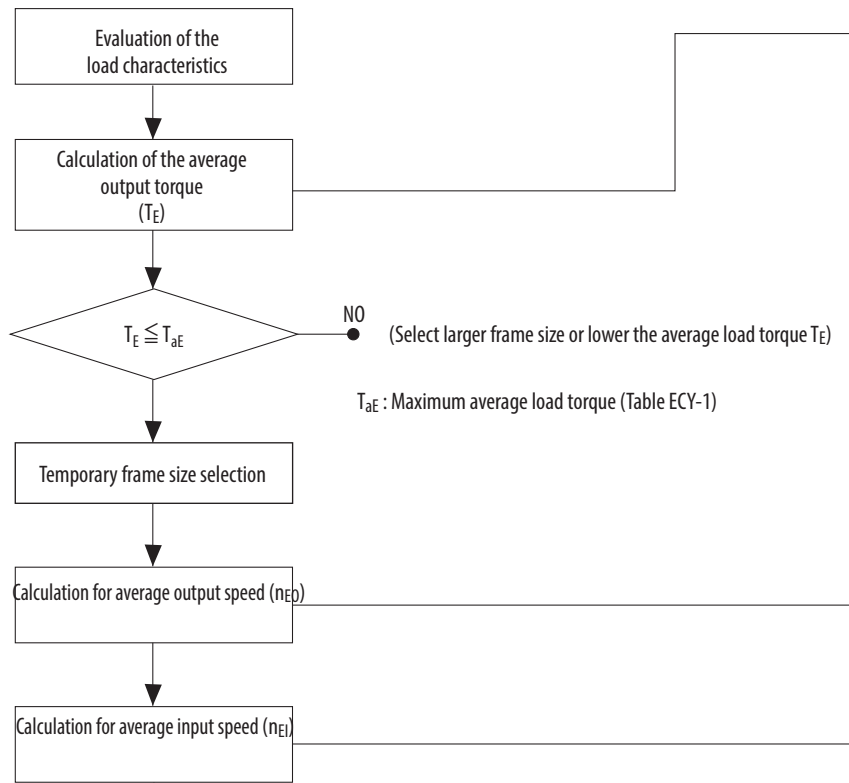

Calculation for the running pattern

○ Average load torque $T_E = \left(\frac{t_A \cdot n_A \cdot T_A^{10/3} + t_R \cdot n_R \cdot T_R^{10/3} + t_B \cdot n_B \cdot T_B^{10/3}}{t_A \cdot n_A + t_R \cdot n_R + t_B \cdot n_B} \right)^{0.3}$

○ Average output speed $n_{E0} = \frac{t_A \cdot n_A + t_R \cdot n_R + t_B \cdot n_B}{T}$
 The longest operation cycle is 10 min.

○ Average input speed $n_{Ei} = n_{E0} \cdot R$
 R: Reduction ratio

Selection example

Following specifications must be confirmed for ECY-107-50:

(Default values) T_A : Peak acceleration and brake torque	80 Nm	t_A : Acceleration time	0.3 s
T_R : Normal running torque	30 Nm	t_R : Normal running time	3.0 s
T_B : Peak torque at braking	60 Nm	t_B : Braking time	0.3 s
Impact torque:	160 Nm	t_p : Idle time	3.6 s
n_A : Average output speed during acceleration/deceleration	25 rpm	t_0 : Total running time	3.6 s
n_R : Output speed during normal operation	50 rpm	T: Cycle time	7.2 s
n_B : Average output speed during deceleration	25 rpm	Radial loads on the input shaft:	100 N
Required lifetime	10,000 hours	Maximum external torque:	150 Nm
It is assumed that the E CYCLO is subject to minimal impacts during use.		Maximum radial load:	500 N

(Calculation) Average load torque $T_E = \left(\frac{0,3 \cdot 25 \cdot 80^{10/3} + 3 \cdot 50 \cdot 30^{10/3} + 0,3 \cdot 25 \cdot 60^{10/3}}{0,3 \cdot 25 + 3 \cdot 50 + 0,3 \cdot 25} \right)^{0.3} = 40 \text{ (Nm)}$

According to Table ECY-1, the maximum average load torque of ECY-107-50 is equal to $T_{aE} = 55 \text{ (Nm)}$.
 $\Rightarrow 40 \text{ (Nm)} \leq 55 \text{ (Nm)}$. Consequently, ECY-107 is provisionally selected.

Maximum input speed $n_{max} = 50 \cdot 50 = 2500 \text{ (rpm)}$

Average output speed $n_{E0} = \frac{0,3 \cdot 25 + 3 \cdot 50 + 0,3 \cdot 25}{7,2} = 22,9 \text{ (r/min)}$

Average input speed $n_{Ei} = 22,9 \cdot 50 = 1145 \text{ (rpm)}$

- Check of maximum input speed 2500 (rpm) \leq 6500 (rpm) P6 (Table ECY-1)
- Check of average input speed 1145 (rpm) \leq 2000 (rpm) P6 (Table ECY-1)
- Check of peak torque during acceleration/deceleration 80 (Nm) \leq 98 (Nm) P6 (Table ECY-1)
- Check of impact torque 160 (Nm) \leq 186 (Nm) P6 (Table ECY-1)
- Check of radial loads on the input shaft 100 (N) \leq 361 (N) (Lf, Cf, Fs1 = 1) P12 (Table ECY-8)
- Check of permissible torque 150 (Nm) \leq 219 (Nm) P10 (Table ECY-2)
- Check of permissible radial load 500 (N) \leq 2050 (N) P10 (Table ECY-2)
- Check of main bearing ($f_w = 1.2$) 36334 (h) \geq 10000 (h) P10 (Table ECY-2)
- Confirmation of static safety coefficient 6.5 \geq 1.5 P10 (Table ECY-2)
- Check of lifetime

According to Table ECY-1, the rated torque of ECY-107-50 is equal to $T_{OE} = 39 \text{ (Nm)}$.

Lifetime $L_{10} = 7000 \cdot \left(\frac{39}{40} \right)^{10/3} \cdot \left(\frac{2000}{1146} \right) = 11433 \text{ (h)} \geq 10000 \text{ (h)}$

ECY-107-50 is selected based on the above considerations.

10.4 Rating

Size	Reduction ratio	Rated output torque Nm	Permissible peak torque during acceleration Nm	Maximum average load torque Nm	Maximum permissible momentary torque Nm	Maximum permissible input speed (rpm)	Permissible average input speed (rpm)	Moment of inertia j related to the input shaft [$\times 10^{-4}$ kgm ²]	Moment of inertia j related to the input shaft [$\times 10^{-4}$ kgm ²]	Weight (kg)
103	50	16	34	26	70	8500	2500	0.13	0.52	0.9
	80	22	43	27	87					
	100	24	54	39	110					
105	50	25	56	34	98	7300	2500	0.30	1.20	1.2
	80	34	74	47	127					
	100	40	82	49	147					
107	50	39	98	55	186	6500	2000	0.62	2.48	1.6
	80	63	137	87	255					
	100	67	157	108	284					

Table ECY-1 Rating data (input speed reference value)

1. Rated torque.

The rated torque indicates the permissible torque at the output flange at an input speed of 2000 rpm.

2. Permissible peak torque during acceleration.

This is the peak torque permitted during normal acceleration.

3. Maximum permissible momentary torque.

This is the permissible value of the impact torque that is applied instantaneously to the output shaft following an emergency stop or an external impact, etc. Indicates the value when 10^4 deflection cycles are applied to the cycloid spline throughout the entire product lifetime.

$$N = \frac{10^4}{2 \cdot \frac{n}{60} \cdot t}$$

N: Permissible speed (rpm) under impact torque
 n: Permissible input speed (rpm) when impact torque is applied
 t: Time during which the impact torque is applied (s)

4. Permissible maximum and permissible average input speed.

Although use is possible within the maximum permissible input speed range, the duty cycle is limited by the permissible average input speed. When a high reduction ratio is used, there is a risk of the E Cyclo overheating and sustaining damage. In order to prevent this problem, the surface temperature of the E Cyclo must not be more than 40 °C higher than the ambient temperature or exceed an absolute value of 60 °C (whichever value is lower).

5. Moment of inertia, GD².

This indicates the value for the moment of inertia GD² on the input shaft of the respective model.

When converting these values (kgf · m · s²), divide the moment of inertia by g (9.8 m/sec²) and GD² by 4g (4 · 9.8 m/s²).

Sold & Serviced By:



Toll Free Phone (877) SERV098
www.electromate.com
sales@electromate.com

10.5 Stiffness

Ratio	Symbol	Measuring unit	Size		
			103	105	107
50	T1	Nm	3.9	7.0	14
	T2	Nm	12	25	48
50	T3	Nm	34	56	98
	K1	Nm/arcmin	3.3	5.3	10.1
		$\times 10^4$ Nm/rad	1.1	1.8	3.5
	K2	Nm/arcmin	3.5	5.5	10.3
		$\times 10^4$ Nm/rad	1.2	1.9	3.5
	K3	Nm/arcmin	4.4	7.1	12.0
		$\times 10^4$ Nm/rad	1.5	2.4	4.1
	θ_1	arcmin	1.2	1.3	1.4
	θ_2	arcmin	3.5	4.6	4.7
θ_3	arcmin	8.5	9.0	8.9	
80	T3	Nm	43	74	137
	K1	Nm/arcmin	3.9	6.6	11.6
		$\times 10^4$ Nm/rad	1.3	2.3	4.0
	K2	Nm/arcmin	4.0	7.4	12.5
		$\times 10^4$ Nm/rad	1.4	2.5	4.3
	K3	Nm/arcmin	5.0	8.5	14.4
		$\times 10^4$ Nm/rad	1.7	2.9	5.0
	θ_1	arcmin	1.0	1.1	1.2
	θ_2	arcmin	3.0	3.5	3.9
θ_3	arcmin	9.2	9.3	10.1	
100	T3	Nm	54	82	157
	K1	Nm/arcmin	3.8	7.7	10.7
		$\times 10^4$ Nm/rad	1.3	2.6	3.7
	K2	Nm/arcmin	4.3	8.2	11.0
		$\times 10^4$ Nm/rad	1.5	2.8	3.8
	K3	Nm/arcmin	5.4	9.5	15.9
		$\times 10^4$ Nm/rad	1.9	3.3	5.5
	θ_1	arcmin	1.0	0.9	1.3
	θ_2	arcmin	2.9	3.1	4.4
θ_3	arcmin	10.7	9.1	11.3	

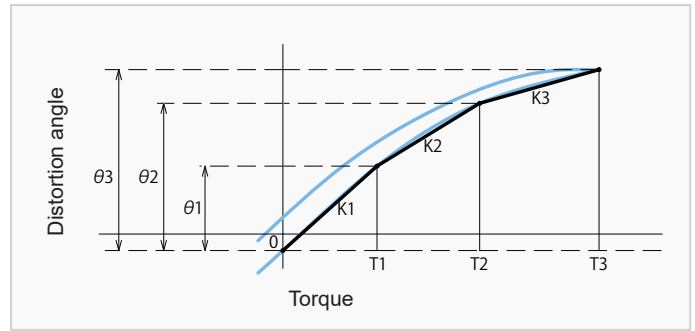

Note arcmin means “angular minute”.
Stiffness values in the tables are mean values.

10.6 No-load running torque NLRT

No-load running torque NLRT: refers to the torque on the input side required to rotate the gear without a load.

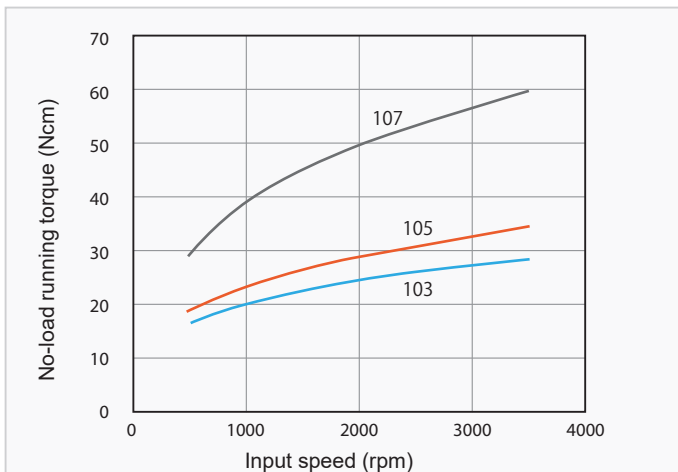

Fig. ECY-1 No-load running torque NLRT

- Notes:
1. Typical values after run-in.
 2. Lubrication: using our standard grease
 3. Surface temperature of the E CYCLO: approx. 40 °C

Sold & Serviced By:



Toll Free Phone (877) SERV098

www.electromate.com

sales@electromate.com

10.7 Breakaway torque on the output shaft

Breakaway torque: Indicates the torque required to start rotation at the output side of the gearbox without a load.

Table 9-2 Breakaway torque on output shaft (Nm)

Reduction ratio	Size		
	103	105	107
50	20	21	22
80	31	34	40
100	33	45	51

- Notes:
1. Typical values after run-in
 2. Lubrication: using our standard grease

10.8 Efficiency

Efficiency: This is the ratio between the actual and the theoretical input torque when the rated torque is applied to the output side. Efficiency varies according to the input speed, load torque, grease temperature, reduction ratio, etc. The figure shows the efficiency values in relation to the input speed at the rated torque and an E CYCLO surface temperature of approximately 40 °C.

When using the E CYCLO under a load torque other than the rated torque, correct the efficiency using the correction curve shown in Fig. ECY-5.

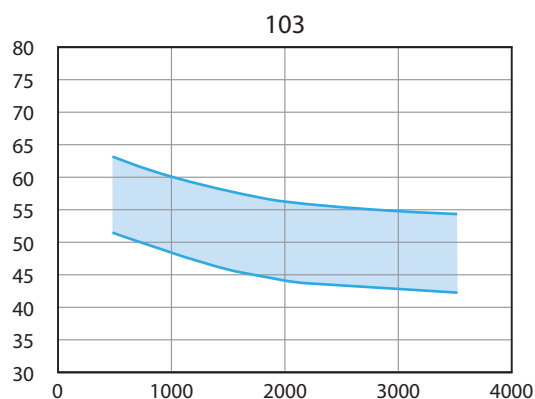

Fig. ECY-2 Efficiency of E Cyclo 103

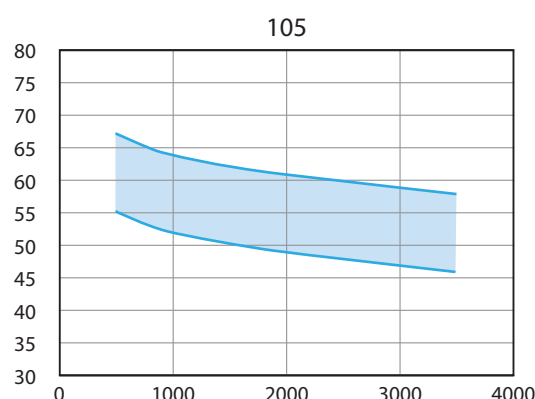

Fig. ECY-4 Efficiency of E Cyclo 105

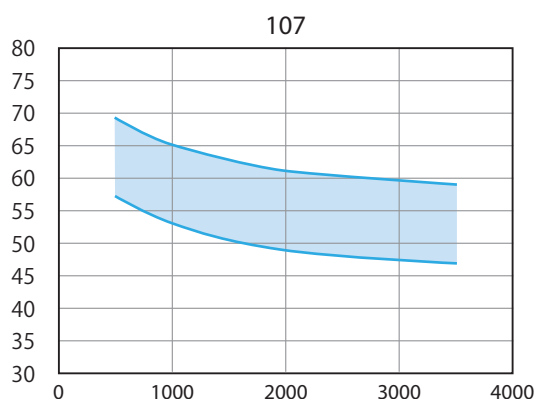

Fig. ECY-3 Efficiency of E Cyclo 107

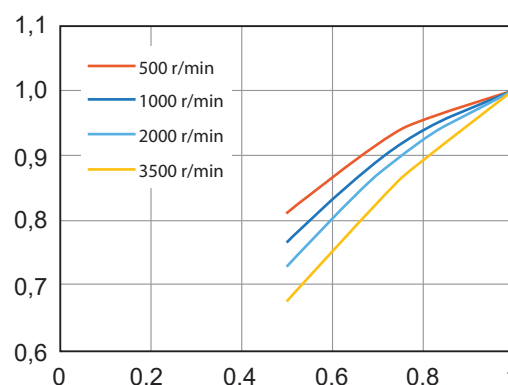

Fig. ECY-5 Efficiency correction curve

Corrected efficiency value = efficiency value x correction factor

- Notes:**
1. The efficiency values are typical values after the run-in time and are displayed within a specific range.
 2. Lubrication: using our standard grease.
 3. Surface temperature of the E CYCLO: approx. 40 °C.

- Notes:**
1. If the load torque is less than the rated torque, the efficiency decreases.
 2. If the torque ratio is 1.0 or higher, the efficiency correction factor is 1.0.

10.9 Main bearings

Size	Pitch circle diameter of main bearing	Offset	Basic dynamic rated load	Basic static rated load	Permissible torque	Permissible radial load	Permissible axial load	Torque stiffness (typical values)
	dp	R	C	C0	Nm	N	N	Nm/arcmin
	mm	mm	N	N				
103	54.7	18.35	9000	18300	105	1300	1590	29.4
105	63.0	19.00	12900	19700	159	1700	1590	42.2
107	72.0	19.45	18100	30400	219	2050	3000	59.1

Table ECY-2 Input side main bearing

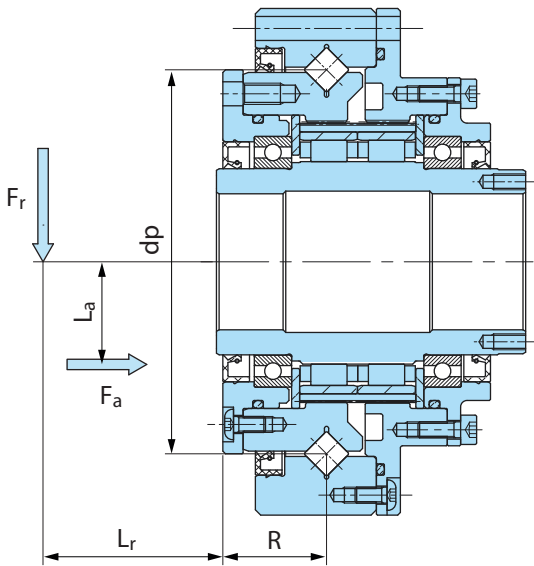

Fig. ECY-6 Load position output

Static safety factor	f_s
If high speed accuracy is required	≥ 3
In event of vibrations and/or impact	≥ 2
Under normal operating conditions	≥ 1.5

Table ECY-3 Static safety factor f_s

Service factor output	B_{f2}
Uniform load	1 – 1.2
Light impacts	1.2 – 1.5
Severe impacts	1.5 – 3

Table ECY-4 Service factor input B_{f1}

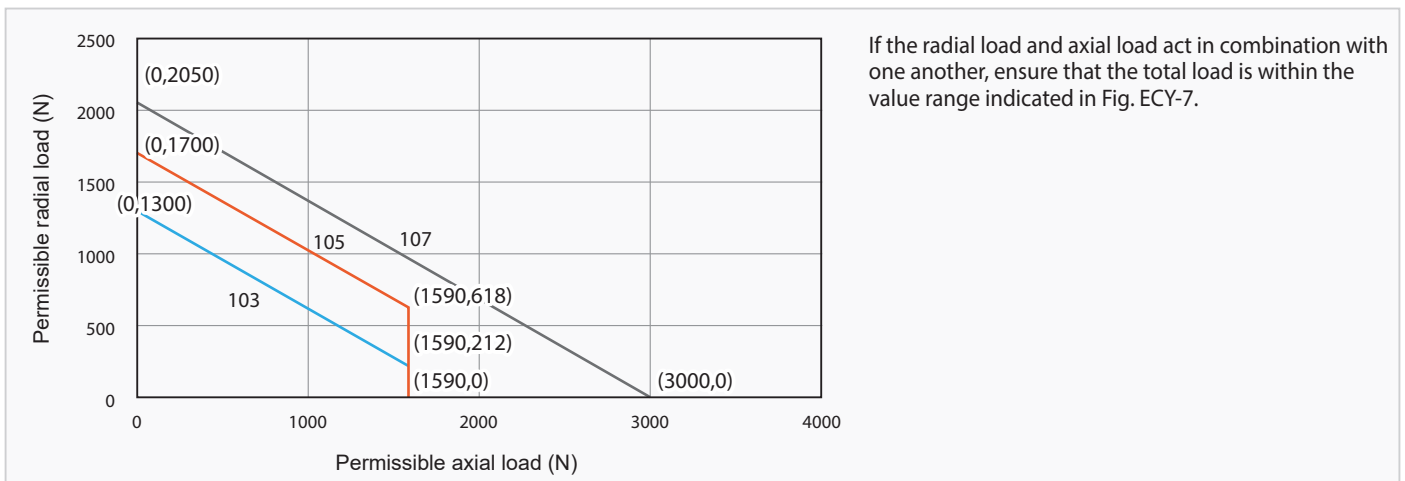

If the radial load and axial load act in combination with one another, ensure that the total load is within the value range indicated in Fig. ECY-7.

Fig. ECY-7 Permissible axial and radial loads

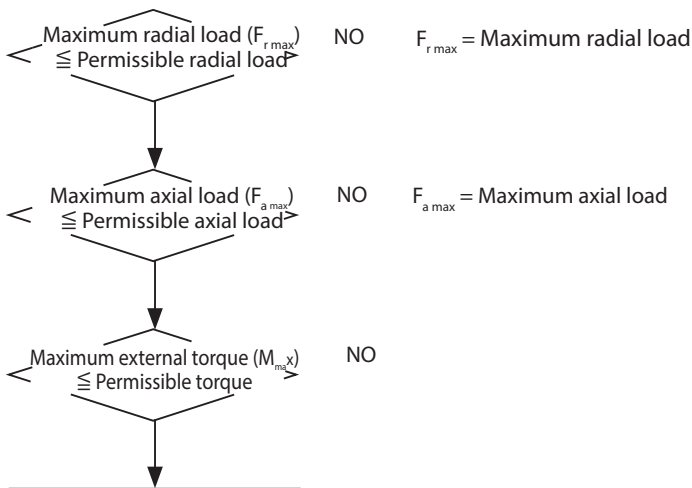

$$M_{max} = F_{r_{max}} \cdot (L_r + R) + F_{a_{max}} \cdot L_a$$

$$F_{ra} = \left(\frac{n_A \cdot t_A \cdot F_{rA}^{10/3} + n_B \cdot t_B \cdot F_{rB}^{10/3} + \dots + n_n \cdot t_n \cdot F_{rn}^{10/3}}{n_A \cdot t_A + n_B \cdot t_B + \dots + n_n \cdot t_n} \right)^{0.3}$$

$$F_{aa} = \left(\frac{n_A \cdot t_A \cdot F_{aA}^{10/3} + n_B \cdot t_B \cdot F_{aB}^{10/3} + \dots + n_n \cdot t_n \cdot F_{an}^{10/3}}{n_A \cdot t_A + n_B \cdot t_B + \dots + n_n \cdot t_n} \right)^{0.3}$$

$$M_a = F_{ra} \cdot (L_r + R) + F_{aa} \cdot L_a$$

Average radial load (F_{ra})
Average axial load (F_{aa})
Average external torque (M_a)

Average output speed (n_{EO})

Dynamic equivalent radial load (P_c)

Dynamic radial factor X_c and dynamic axial factor Y_c

$$\frac{F_{aa}}{F_{ra} + 2M_a/dp} \leq 1.5 \quad X_c = 1.0 \quad Y_c = 0.45$$

$$\frac{F_{aa}}{F_{ra} + 2M_a/dp} > 1.5 \quad X_c = 0.67 \quad Y_c = 0.67$$

$$P_c = X_c \cdot \left(F_{ra} + \frac{2M_a}{dp} \right) + Y_c \cdot F_{aa}$$

Calculation of lifetime of main bearing (L_{10})

$$L_{10} = \frac{10^6}{60 \cdot n_{EO}} \cdot \left(\frac{C}{B_{f2} \cdot P_c} \right)^{10/3}$$

Static equivalent radial load (P_o)

$$P_o = F_{Rmax} + \frac{2M_{max}}{dp} + 0.44 F_{a_{max}}$$

Static safety factor (f_s)

$$f_s = \frac{C_o}{P_o}$$

Sold & Serviced By:

 Toll Free Phone (877) SERV098
www.electromate.com
sales@electromate.com

10.10 Bearing loads

10.10.1 Maximum permissible radial and axial load on the input shaft

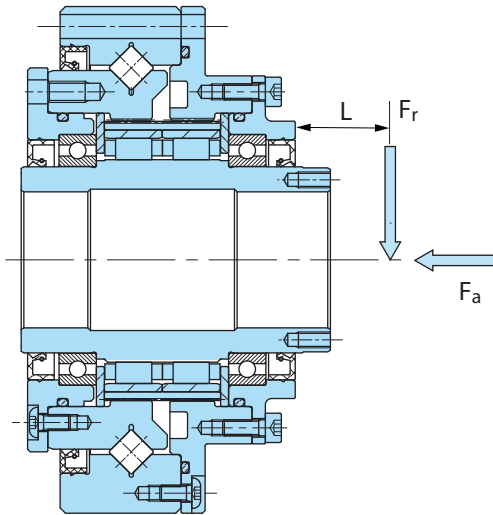

L [mm]	Load factor input L_{f1}		
	Size		
	103	105	107
5	1.01	0.99	0.97
10	1.13	1.10	1.07
15	1.25	1.21	1.18
20	1.37	1.32	1.28
25	1.49	1.43	1.39
30	1.61	1.54	1.49
35	1.73	1.65	1.60
40	-	-	1.70
L (mm), if $L_f = 1$ (mm)	4.6	5.5	6.6

Table ECY-5 Load factor input L_{f1}
L = distance from input side carrier

Note Use linear addition to calculate the load factor L_{f1} at load position L, which is not shown in the table.

When mounting a gear, pulley or roller on an input shaft: Operate the gearbox in such a way that the radial and axial loads do not exceed the permissible values. Check the radial load and axial load of the input shaft using the following equations (ECY-1 to 3).

1. Input side radial load F_R

$$F_R = \frac{T_I}{r_0} \leq \frac{F_{Rmax}}{L_f \cdot C_{f1} \cdot B_{f1}} \quad [\text{N}] \quad (\text{Equation ECY-1})$$

2. Input side axial load F_A

$$F_A \leq \frac{F_{Amax}}{C_{f1} \cdot B_{f1}} \quad [\text{N}] \quad (\text{Equation ECY-2})$$

3. When radial and axial loads co-exist

$$\left(\frac{F_R \cdot L_f}{F_{Rmax}} + \frac{F_{A1}}{F_{Amax}} \right) \cdot C_{f1} \cdot B_{f1} \leq 1 \quad (\text{Equation ECY-3})$$

F_R = Input side radial load [N]

T_I = Actual transmission torque at output shaft [Nm]

r_0 = pitch circle radius of sprocket, pinion, or timing belt pulley [m]

F_{Rmax} = maximum permissible input side radial load [N] (Table ECY-8)

F_A = input side axial load [N]

F_{Amax} = max. permissible input side axial load [N] (Table ECY-5)

L_{f1} = load factor input (Table ECY-5)

C_{f1} = correction factor input (Table ECY-6)

B_{f1} = service factor input (Table ECY-7)

L = distance of radial load from front end on input side of the input shaft [mm] (Table ECY-5)

Correction factor input	C_{f1}
Chain	1
Gear or pinion	1.25
Timing belt	1.25
V-Belt	1.5

Table ECY-6 Correction factor input C_{f1}

Service factor input	B_{f1}
Uniform load	1
Light impacts	1 – 1.2
Severe impacts	1.4 – 1.6

Table ECY-7 Service factor input B_{f1}

Size	Input speed n_{1m} [min ⁻¹]								
	4000	3000	2500	2000	1750	1500	1000	750	600
103	198	218	232	250	261	275	315	347	373
105	218	240	255	275	288	303	346	381	411
107	238	262	278	300	314	330	378	416	448

Table ECY-8 Max. permissible input side radial load $F_{R\max}$ [N]

Size	Input speed n_{1m} [min ⁻¹]								
	4000	3000	2500	2000	1750	1500	1000	750	600
103	169	191	207	228	242	259	308	349	385
105	186	210	228	250	266	284	339	384	424
107	212	240	260	283	303	324	387	439	483

Table ECY-9 Max. permissible input side axial load $F_{A\max}$ [N]

Note The permissible radial and axial loads at an input speed of less than 600 rpm are the same as the values for 600 rpm.

Calculation of the max. permissible radial load on the input shaft

Calculation of the max. permissible radial load using the following equation when the speed is not shown in the table above.

$$F_{R\max} = F_{R,2000} \left(\frac{2000}{n_{1m}} \right)^{1/3}$$

$F_{R\max}$ = maximum permissible input side radial load at input speed n_{1m}

$F_{R,2000}$ = Input side radial load at input speed $n_{1m} = 600$ rpm

Calculation of the max. permissible axial load on the input shaft

Calculation of the max. permissible axial load using the following equation when the speed is not shown in the table above.

$$F_{A\max} = F_{A,2000} \left(\frac{2000}{n_{1m}} \right)^{0.44}$$

$F_{A\max}$ = maximum permissible input side axial load at input speed n_{1m}

$F_{A,2000}$ = Axial load on input side at input speed $n_{1m} = 2000$ rpm

Sold & Serviced By:



Toll Free Phone (877) SERV098

www.electromate.com

sales@electromate.com

10.11 Notes on installation

10.11.1 Installation method

Use spigot C when assembling the input drive parts (pulleys and gears).
 Use spigot B to assemble the gearbox output side and spigot A to assemble the housing.

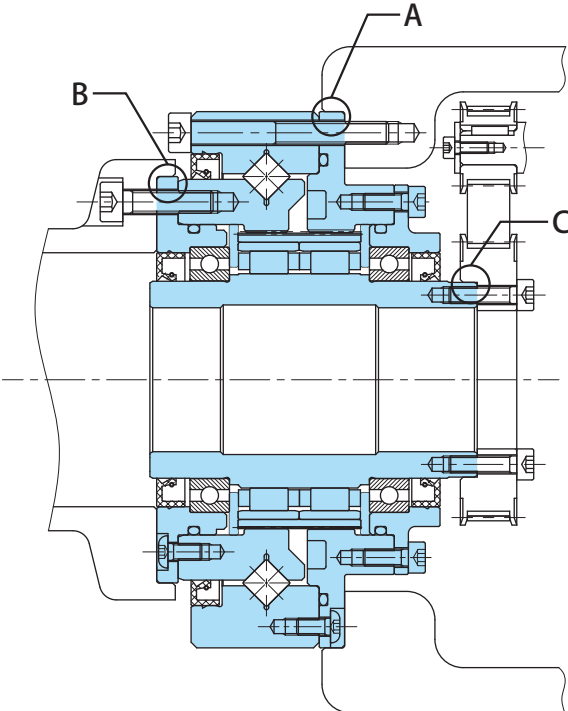

Fig. ECY-8 Installation of E CYCLO

10.11.2 Bolt tightening torque and maximum permissible transmittable torque for bolts

Tables ECY Table ECY-10 to Table ECY-12 show the number, size and tightening torque of bolts for securing the input and output side of the E CYCLO.

Size	Tightening the output flange			
	Quantity and size of screws	Pitch circle diameter mm	Screw tightening torque	Max. permissible transmitted torque for bolts
			Nm	Nm
103	16-M3	48.0	1.96	163
105	16-M3	55.5	1.96	189
107	16-M4	63.0	4.61	374

Table ECY-10

Size	Securing the housing			
	Quantity and size of screws	Pitch circle diameter mm	Screw tightening torque	Max. permissible transmitted torque by bolts
			Nm	Nm
103	16-M3	68	1.96	232
105	16-M3	78	1.96	266
107	16-M4	87.5	4.61	520

Table ECY-11

Size	Securing the input shaft			
	Quantity and size of screws	Pitch circle diameter mm	Screw tightening torque	Max. permissible transmitted torque by bolts
			Nm	Nm
103	6-M2	22	0.55	14
105	8-M2	24	0.55	20
107	6-M3	30	1.96	45

Table ECY-12

- **Bolting:** Use metric hexagon socket head screws (DIN 4762, strength category 12.9).
- **Countermeasure for bolts loosening:** Use adhesives (Loctite 262, etc.) or spring washer (DIN 127A).
- **Use spring washers** (DIN 6796) when connecting the gearbox to the flange side, so that the bolt contact faces do not get damaged.

10.11.3 Installation example

[1]  Secure the gearbox to the machine housing using bolts.
(centring (A))
 * Make sure that the centring (A) is not wider than the fixed flange.
 Then apply liquid sealant to the mounting surface, if necessary.

Figure 13-2

[2]  Screw the pulley and the remaining input parts to the input shaft.
(centring (C))

Figure 13-3

[3]  Bolt the outside cover (including the internal gear) to the output shaft on the device.
(centring (B))

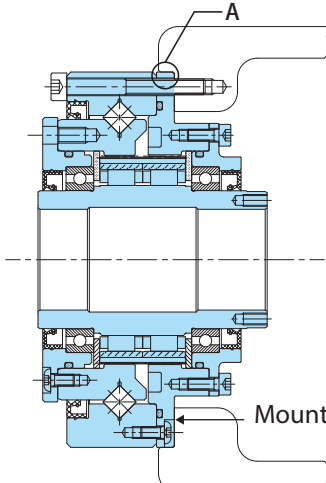
Figure 13-4

- Notes:
1. When installing the gearbox, tighten the bolts to the specified tightening torque (see Table ECY-10).
 2. When bolting the output shaft to the external cover (including the ring gear), set the bolt length shorter than the thread depth shown on enlarged part A of the outline drawing (see from Page 162).

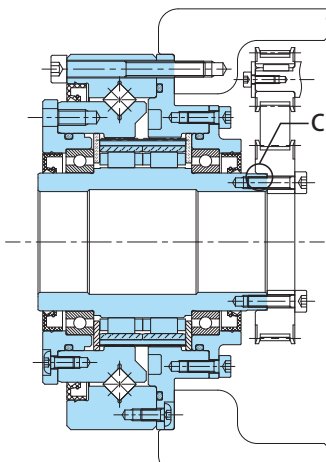
10.11.4 Lubrication

E CYCLO is delivered already lubricated and sealed with HGO-3 No. 00 from Nippeco.

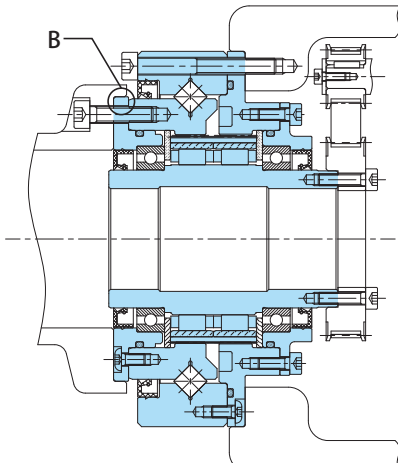
Replace the grease every 20,000 operating hours or every three to five years.

Size	103		105 (i = 50, 80)		105 (i = 100)		107	
	g	ml	g	ml	g	ml	g	ml
Grease quantity	7	8	14	16	10	12	16	18

The relative density is assumed to be 0.87 g/ml.

Table ECY-13

Brand name	HGO-3
Base oil	Refined mineral oil
Thickener	Lithium soap
Additive	Extreme pressure additives, etc.
Consistency no.	No. 00
Consistency (at 25 °C)	400-430
Appearance	Light brown

Table ECY-14

Sold & Serviced By:



Toll Free Phone (877) SERV098

www.electromate.com

sales@electromate.com

10.12 Dimensioned drawings

ECY - 103

Weight 0.9 kg

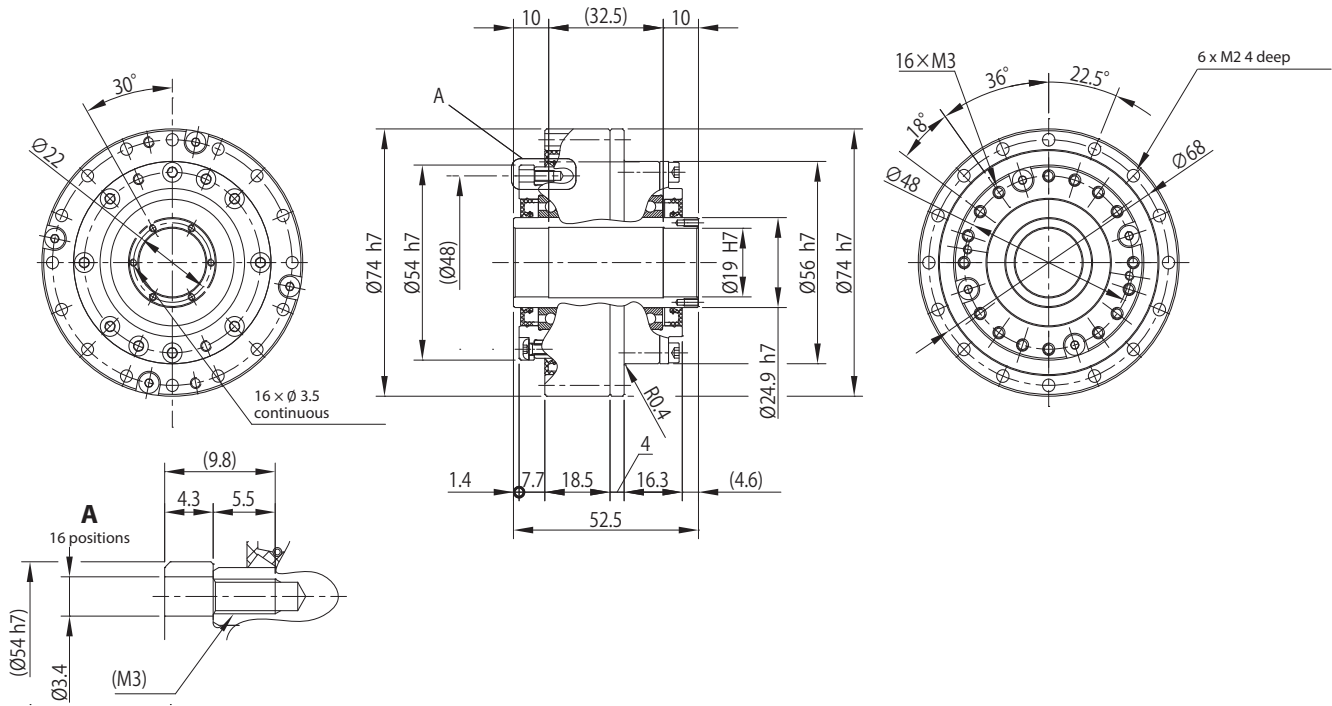

ECY - 105

Weight 1.2 kg

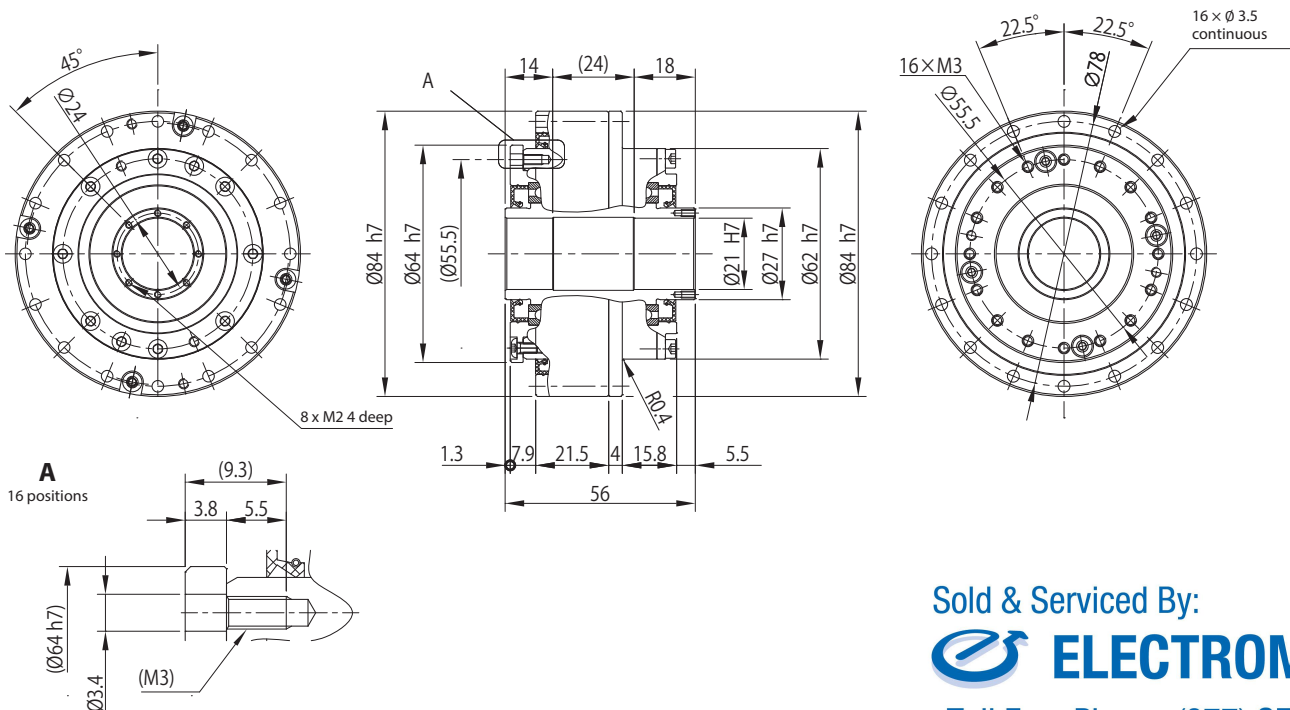

Sold & Serviced By:

ELECTROMATE

Toll Free Phone (877) SERV098

www.electromate.com

sales@electromate.com

11 Appendix

Precision gearbox - application data sheet

Specific application data is required for the selection of a suitable precision gearbox. Please complete the following data sheet to enable us to respond quickly. Thank you.

1. Load cycle:

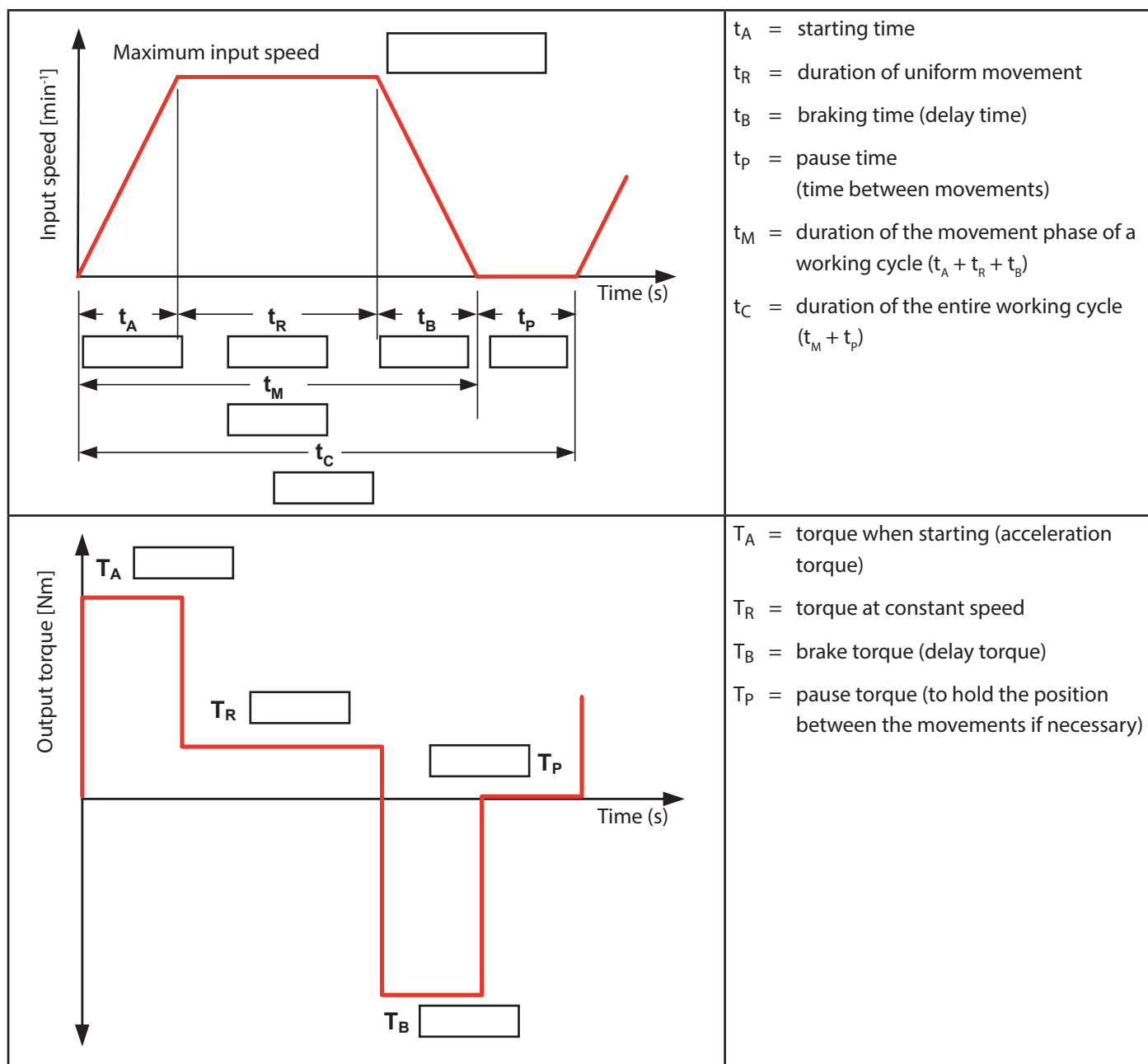

Precision gearbox - application data sheet

2. **What is the required reduction ratio?** _____ : 1

3. **Please specify the following input power data (motor):**

1. Nominal speed: _____ [min⁻¹]

2. Continuous static torque: _____ [Nm]

3. Peak torque: _____ [Nm]

4. Manufacturer: _____

5. Model number: _____

4. **Is a hollow shaft required?**

- yes If applicable, how large? _____
 no

5. **Should Sumitomo provide an input adapter?**

- yes
 no

If you have selected "Yes", please specify the dimensions of the input or submit a copy of the dimensioned drawing.

Is it a motor shaft with or without a key?

- With key
 Without key

6. **How is the gearbox connected to the motor?**

- Direct coupling
 Timing belt or chain drive (continue with No. 6a)
 V-belt (continue with No. 6a)
 Spur gear (continue with No. 6a)
 Other (continue with No. 6a)

6a. **Definition of prestage**

Inertia kg·m²
 Ratio

7. **How is the gearbox connected to the final load?**

- Direct coupling
 Timing belt or chain drive
 Spur gear
 Other

8. **Please select one of the following load properties:**

- Uniform load
 Moderate impact load
 Heavy impact load

Sold & Serviced By:

 **ELECTROMATE**

Toll Free Phone (877) SERV098
www.electromate.com
sales@electromate.com

9. Radial and axial load

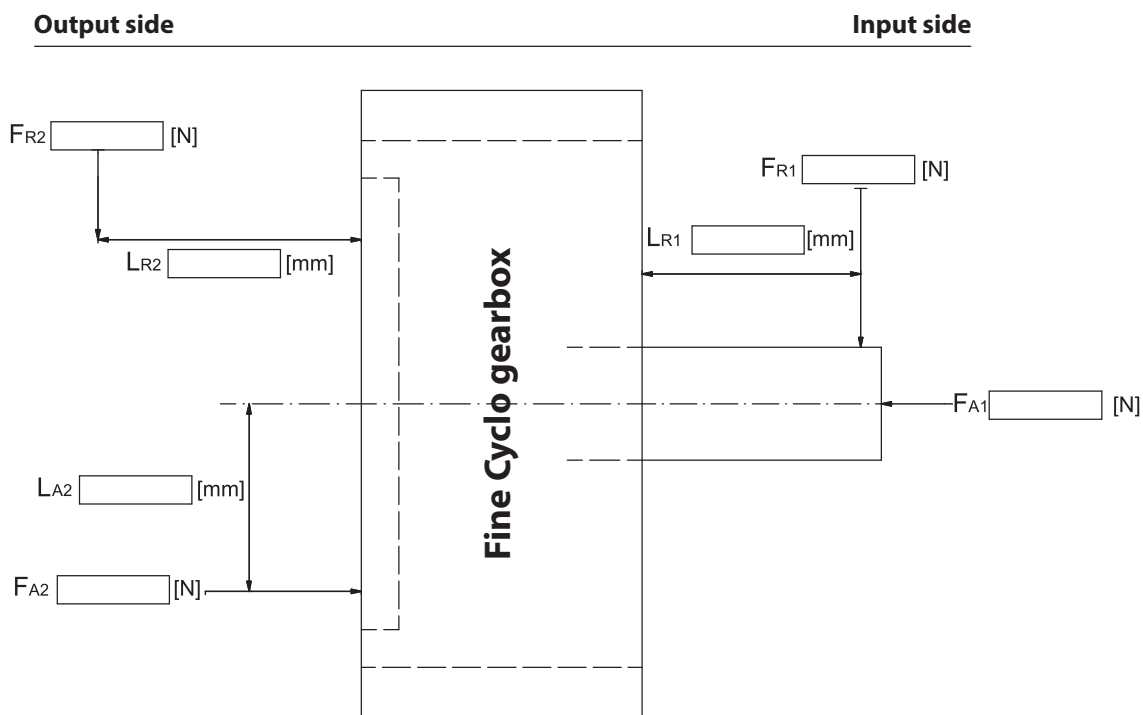

- F_R = radial load
- L_R = distance from radial force to flange collar
- F_A = axial load
- L_A = distance of the axial load from the centre line
- 1: Input side
- 2: Output side

10. Please describe your application in as much detail as possible (if possible, please enclose drawing).