

SHIMPO

VRB-Series

ABLE

Planetary Servo Reducers



New Performance Leader

- Industry Standard Mounting Dimensions
- Thru-bolt Mounting Style
- Best-In-Class Backlash (≤ 3 arc-min)
- Ships in 48 hours
- Assembled in the USA

Sold & Serviced By:

 **ELECTROMATE**

Toll Free Phone (877) SERV098

Toll Free Fax (877) SERV099

www.electromate.com

sales@electromate.com

A Nidec Group Company

SHIMPO

All for dreams

VRB DIMENSIONS

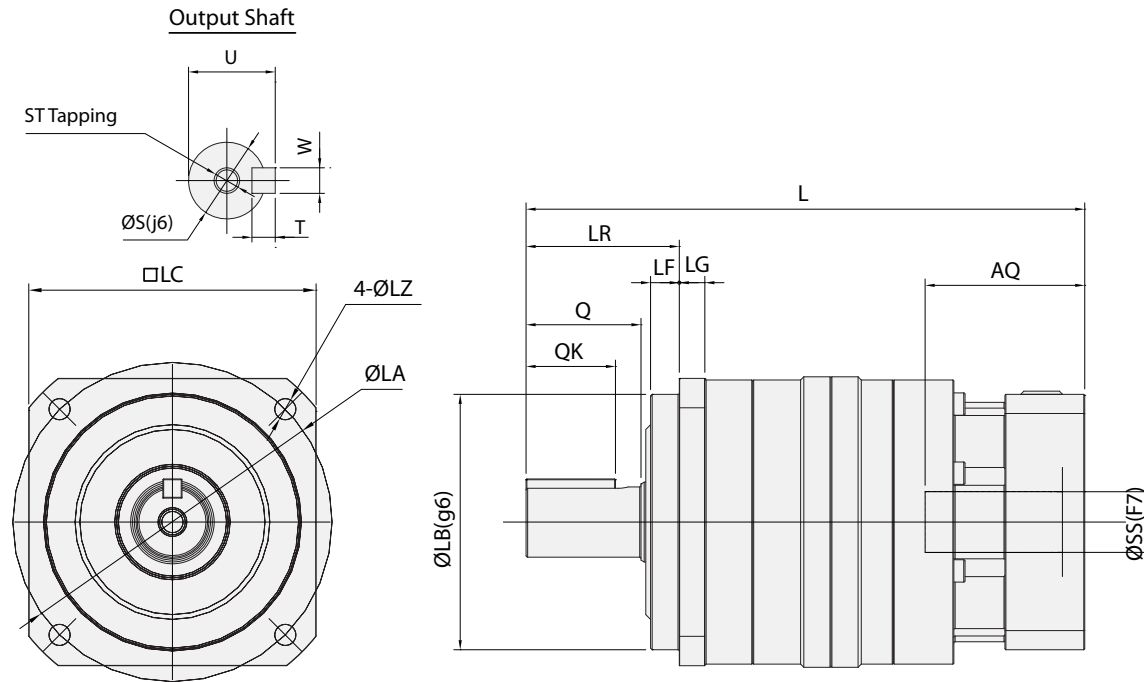

Frame	Reduction	SS	LA	LB	LC	L	LR	LF	LG	LZ	Q	QK	AQ	S	T	W	U	ST
060	Single	8	70	50	60	112	37	6	6	5.5	28	22	32	16	5	5	18	M5
		14				35												
		19				50												
	Double	8				131							32					
		14				136							35					
090	Single	14	100	80	90	143	48	9	8	6.6	36	28	35	22	6	6	24.5	M8
		19				50												
		28				67												
	Double	8				160							32					
		14				165							35					
		19				175							50					
115	Single	19	130	110	115	187	65	4	10	9	58	45	50	32	8	10	35	M12
		28				67												
		38				82												
	Double	14				204.5							35					
		19				214.5							50					
		28				231.5							67					
140	Single	28	165	130	140	249	97	12	12	11	82	65	67	40	8	12	43	M16
		38				82												
		48				118												
	Double	19				266.5							50					
		28				283.5							67					
		38				298.5							82					
180	Single	38	215	160	180	286.5	105	20	15	13.5	82	65	82	55	10	16	59	M20
		48				98												
		65				122												
	Double	28				316							67					
		38				331							82					
		48				367							98					
220	Single	48	250	180	220	367.5	138	30	20	17	105	85	98	75	12	20	79.5	M20
		65				122												
	Double	38				366.5							77					
		48				402.5							98					

Note 1: Depending on installed servo motor, the L dimension varies slightly.

Note 2: For other input shaft dimensions, bushing is installed into input shaft.

Note 3: Single reduction 3-10:1. Double reduction 15-100:1.

Note 4: Contact Shimpo for dimensional data for 042 and 240 frame sizes.

Note 5: Dimensions in mm.

Note 6: Also available in right angle.

VRB SPECIFICATIONS

Specification	Frame	060		090		115	
	Ratio	Single Reduction	Double Reduction	Single Reduction	Double Reduction	Single Reduction	Double Reduction
Nominal Output Torque	Nm	27	27	75	75	180	180
Maximum Output Torque	Nm	50	50	125	125	330	330
Emergency Stop Torque	Nm	100	100	250	250	625	625
Backlash	arc-min	3	3	3	3	3	3
Nominal Input Speed	rpm	3000	3000	3000	3000	3000	3000
Maximum Input Speed	rpm	6000	6000	6000	6000	6000	6000
Allowable Radial Load	N	640	1200	1200	2400	2000	4300
Allowable Thrust Load	N	530	1100	1600	2200	2500	3900
Weight	kg	1.4	1.6	3.7	4.2	8.0	8.9
Unit Life	hrs	20000	20000	20000	20000	20000	20000
Protection*		IP40	IP40	IP40	IP40	IP40	IP40
Moment of Inertia	kgcm ²	Contact us for the details					

Speed Reduction Ratios	Single	3,4,5,6,7,8,9,10:1
	Double	15,16,20,25,28,30,35,40,45,50,60,70,80,90,100:1

Note: Contact Shimpo for dimensional data for 042 and 240 frame sizes.

* Unit can achieve IP65 rating with appropriate sealant added between adapter and motor connection.

Contact Shimpo for details if IP65 rating is necessary.

Specification	Frame	140		180		220	
	Ratio	Single Reduction	Double Reduction	Single Reduction	Double Reduction	Single Reduction	Double Reduction
Nominal Output Torque	Nm	360	360	750	750	1500	1500
Maximum Output Torque	Nm	700	700	1400	1400	2300	2300
Emergency Stop Torque	Nm	1250	1250	2750	2750	5000	5000
Backlash	arc-min	3	3	3	3	3	3
Nominal Input Speed	rpm	2000	2000	1500	1500	1000	1000
Maximum Input Speed	rpm	4000	4000	3000	3000	2000	2000
Allowable Radial Load	N	4700	9100	15000	15000	15000	15000
Allowable Thrust Load	N	4100	8200	14000	14000	14000	14000
Weight	kg	16	17	36	37	53	54
Unit Life	hrs	20000	20000	20000	20000	20000	20000
Protection*		IP40	IP40	IP40	IP40	IP40	IP40
Moment of Inertia	kgcm ²	Contact us for the details					

Speed Reduction Ratios	Single	3,4,5,6,7,8,9,10:1
	Double	15,16,20,25,28,30,35,40,45,50,60,70,80,90,100:1

Note: Contact Shimpo for dimensional data for 042 and 240 frame sizes.

* Unit can achieve IP65 rating with appropriate sealant added between adapter and motor connection.

Contact Shimpo for details if IP65 rating is necessary.

Improving the Speed of Industry

Servo Motor Planetary Gear Reducers



ABLE Inline Series



ABLE Right Angle Series



ABLE with Rotary Stage

Mechanical Adjustable Speed Drives



Standard Ringcone



Ringcone Motor Assembly

Industrial Duty Speed Reducers



Circulute Cycloidal Reducer



Circulute with Servo Input



Circulute Pulley Style

Sold & Serviced By:

 **ELECTROMATE**

Toll Free Phone (877) SERV098

Toll Free Fax (877) SERV099

www.electromate.com

sales@electromate.com

A **Nidec** Group Company

SHIMPO All for dreams