

Gearhead Ordering Information

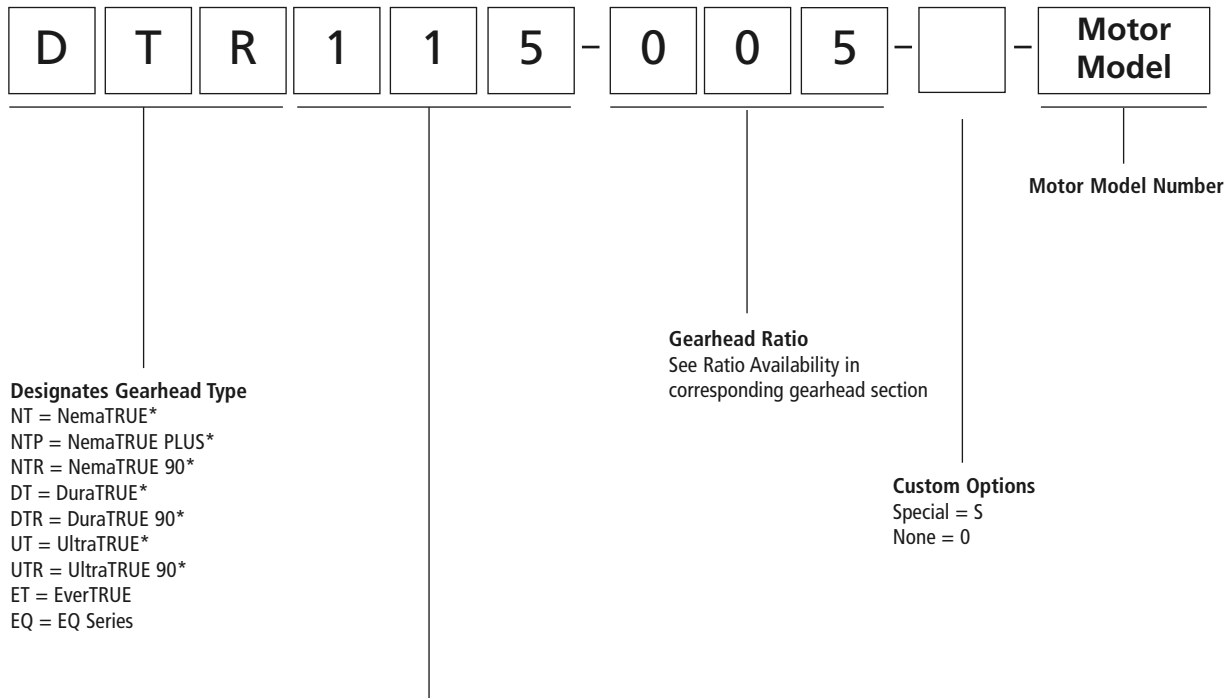

GEARHEAD SIZE

NemaTRUE NemaTRUE PLUS NemaTRUE 90

17 = Size 17
 23 = Size 23
 34 = Size 34
 42 = Size 42
 60 = Size 60
 90 = Size 90
 115 = Size 115

DuraTRUE DuraTRUE 90 DuraTRUE Hollow Shaft DuraTRUE Dual Shaft

60 = Size 60
 90 = Size 90
 115 = Size 115
 142 = Size 142

UltraTRUE UltraTRUE 90

006 = Size 60
 075 = Size 75
 090 = Size 90
 010 = Size 10
 115 = Size 115

EverTRUE

10 = Size 10
 14 = Size 14
 18 = Size 18

EQ

23 / 60 = Size 23 / 60mm

Sold & Serviced By:

 **ELECTROMATE**

Toll Free Phone (877) SERV098

Toll Free Fax (877) SERV098

www.electromate.com

sales@electromate.com

MICRON

©2003 Danaher Motion. Printed in the U.S.A. The specifications in this publication are believed to be accurate and reliable. However, it is the responsibility of the product user to determine the suitability of Micron products for a specific application. While defective products will be replaced without charge if promptly returned, no liability is assumed beyond such replacement.

NemaTRUE* True Planetary* Gearheads

Ready for Immediate Delivery

Precision: 13 arc-minutes
Frame Sizes: 17, 23/60mm, 34/90mm, and 42/115mm
Torque Capacity: up to 1600 in-lb

Ratio Availability: 3:1 thru 100:1
Radial load capacity: up to 840 lb
Mounting System: RediMount*

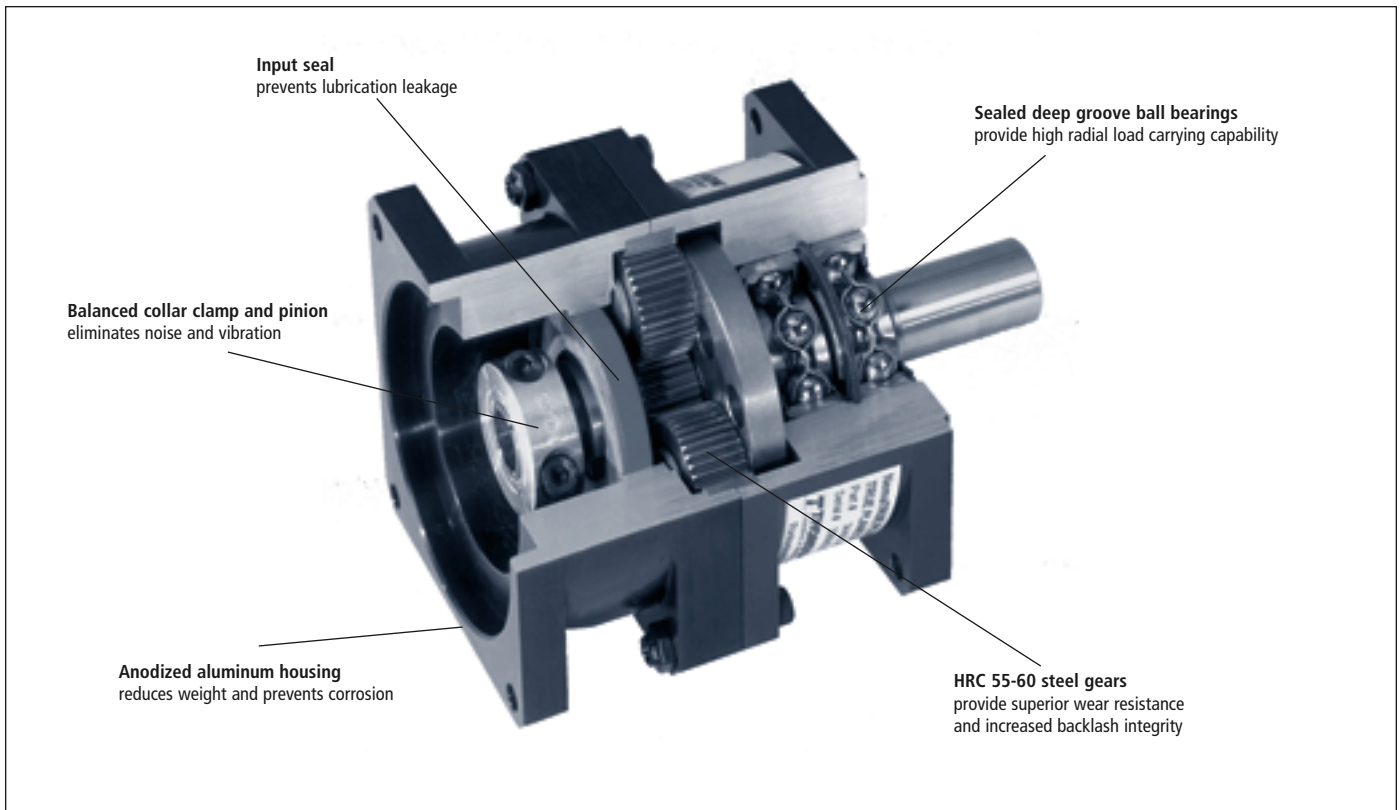

Index	Page
Sizing	12
NemaTRUE 17 Planetary Gearhead	13
NemaTRUE 23/60 Planetary Gearhead	14
NemaTRUE 34/90 Planetary Gearhead	15
NemaTRUE 42/115 Planetary Gearhead	16
Selection	10
Mounting Tools	84

Sold & Serviced By:

 **ELECTROMATE**

Toll Free Phone (877) SERV098

Toll Free Fax (877) 627-098

www.electromate.com

sales@electromate.com

MICRON

©2003 Danaher Motion. Printed in the U.S.A. The specifications in this publication are believed to be accurate and reliable. However, it is the responsibility of the product user to determine the suitability of Micron products for a specific application. While defective products will be replaced without charge if promptly returned, no liability is assumed beyond such replacement.

NemaTRUE* Size 17 True Planetary* Gearheads

English

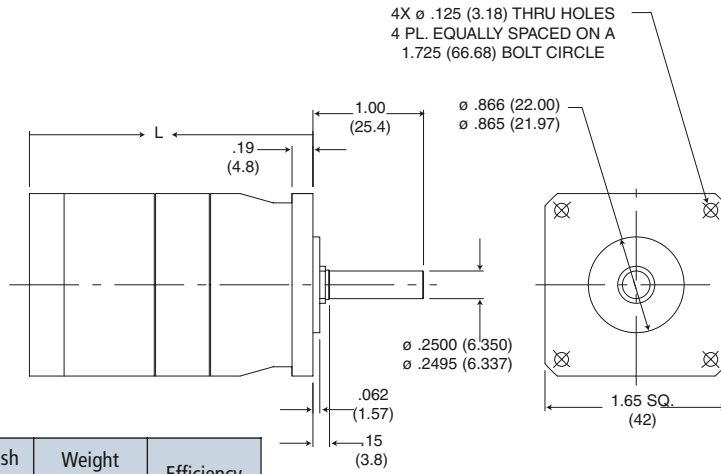

Ratio	Dimension 'L' in (mm)	Backlash (arc-min)	Weight lb (kg)	Efficiency
3:1 to 10:1	1.75 (44)	13 max	.75 (0.34)	90%
15:1 to 100:1	2.25 (57)	15 max	.95 (0.43)	85%

(TABLE 1) PERFORMANCE SPECIFICATIONS

Part Number	Ratio ¹	10,000 HOUR LIFE				T _{peak} in-lb (Nm)	J in-lb-sec ² x10 ⁻⁴ (kg-cm ²)	Torsional Stiffness in-lb/arc-min (Nm/arc-min)
		T _r (1000 rpm) in-lb (Nm)	T _r (2000 rpm) in-lb (Nm)	T _r (3000 rpm) in-lb (Nm)	T _r (4000 rpm) in-lb (Nm)			
NT17-003	3:1	41 (4.7)	34 (3.8)	29 (3.3)	27 (3.1)	170 (19.2)	0.115 (0.013)	2.36 (0.268)
NT17-005	5:1	44 (5.0)	37 (4.2)	33 (3.7)	30 (3.4)	170 (19.2)	0.040 (0.005)	2.36 (0.268)
NT17-010	10:1	30 (3.4)	28 (3.1)	25 (2.8)	23 (2.6)	170 (19.2)	0.030 (0.003)	2.36 (0.268)
NT17-015	15:1	47 (5.3)	47 (5.3)	47 (5.3)	42 (4.7)	170 (19.2)	0.037 (0.004)	2.36 (0.268)
NT17-025	25:1	78 (8.8)	58 (6.6)	53 (6.0)	48 (5.5)	170 (19.2)	0.037 (0.004)	2.36 (0.268)
NT17-030	30:1	57 (6.4)	52 (5.9)	48 (5.4)	46 (5.2)	170 (19.2)	0.026 (0.003)	2.36 (0.268)
NT17-050	50:1	91 (10.3)	78 (8.8)	65 (7.4)	60 (6.7)	170 (19.2)	0.026 (0.003)	2.36 (0.268)
NT17-100	100:1	40 (4.5)	38 (4.3)	35 (4.0)	33 (3.8)	170 (19.2)	0.026 (0.003)	2.36 (0.268)

¹ Ratios are exact, higher ratios are also available, consult factory.
 T_r = Rated output torque at rated speed for specific hours of life.
 J = Mass moment of inertia reflected to the input shaft (including pinion assembly)
 T_{peak} = Allowable momentary peak torque for emergency stop or heavy shock loading.
 See page 10 for gearhead selection criteria

(TABLE 2) RADIAL AND AXIAL LOAD RATINGS

This graph displays the allowable radial load at a given distance (X) from the mounting surface based on an L10 life of 10,000 hours for the mean output speed n_{mout}, as described on page 10.

NT17 Radial Loadings

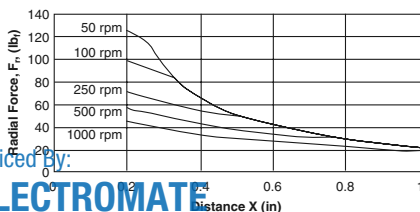

NT17 Axial Loadings

Speed (rpm)	Axial Load, F _a (lbf)	N
50	237	(1054)
100	188	(836)
250	138	(614)
500	110	(489)
1000	87	(387)

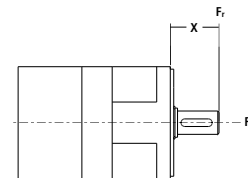

Sold & Serviced By:

 Toll Free Phone (877) SERV098
 Toll Free Fax (877) SERV099
 www.electromate.com
 sales@electromate.com

© 2009 Danaher Motion. Printed in the U.S.A. The specifications in this publication are believed to be accurate and reliable. However, it is the responsibility of the product user to determine the suitability of Micron products for a specific application. While defective products will be replaced without charge if promptly returned, no liability is assumed beyond such replacement.



* Trademark of Danaher Motion. DANAHER MOTION is registered in the U.S. Patent and Trademark Office and in other countries.

NemaTRUE* Size 23/60mm True Planetary* Gearheads

NemaTRUE* English

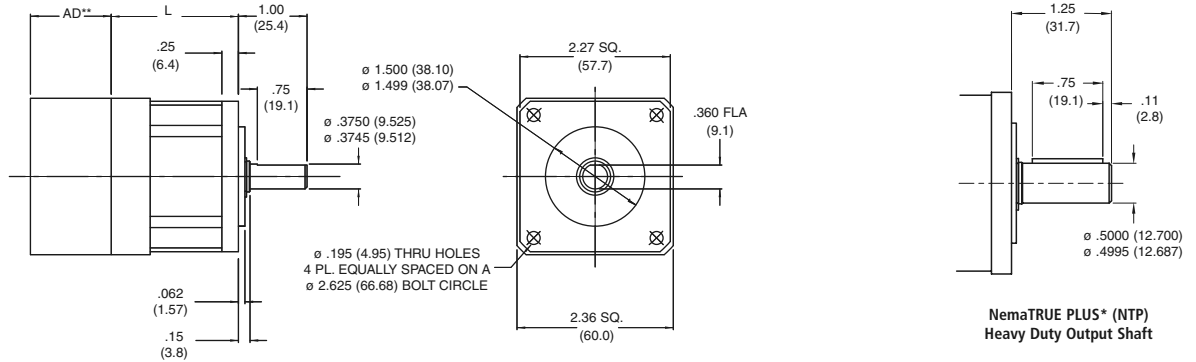

NemaTRUE* Metric

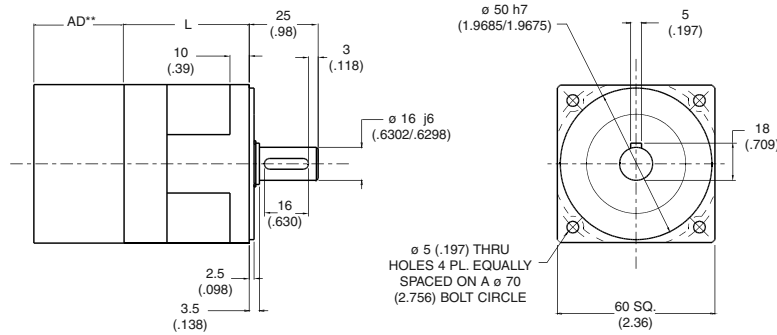

Ratio	NT23 Dimension 'L' in (in)	NT60 Dimension 'L' in (mm)	Backlash (arc-min)		Weight lb (Kg)	Efficiency
			Precision	High Precision		
3:1 to 10:1	1.92 (48.8)	2.07 (52.6)	13 max	8 max	1.5 (0.7)	90%
15:1 to 100:1	2.61 (66.3)	2.76 (70.1)	15 max	9 max	1.9 (0.9)	85%

All dimensions are: mm (inches)

AD** = Adapter length. Adapter length will vary depending on motor.

(TABLE 1) PERFORMANCE SPECIFICATIONS

Part Number		Ratio ¹	10,000 HOUR LIFE				T _{peak} in-lb (Nm)	J in-lb-sec ² x10 ⁻⁴ (kg-cm ²)	Torsional Stiffness in-lb/arc-min (Nm/arc-min)	
			T _r (1000 rpm) in-lb (Nm)	T _r (2000 rpm) in-lb (Nm)	T _r (3000 rpm) in-lb (Nm)	T _r (4000 rpm) in-lb (Nm)			NT	NTP
English	Metric									
NT23-003	NT60-003	3:1	98 (11.1)	80 (9.0)	70 (7.9)	65 (7.3)	150 (16.9)	0.67 (0.076)	6.3 (0.71)	15.8 (1.8)
NT23-004	NT60-004	4:1	107 (12.1)	90 (10.2)	80 (9.0)	73 (8.2)	250 (28.3)	0.22 (0.024)	6.3 (0.71)	15.8 (1.8)
NT23-005	NT60-005	5:1	105 (11.9)	88 (9.9)	78 (8.8)	71 (8.0)	250 (28.2)	0.22 (0.025)	6.3 (0.71)	15.8 (1.8)
NT23-007	NT60-007	7:1	100 (11.3)	83 (9.4)	74 (8.4)	66 (7.5)	250 (28.3)	0.22 (0.024)	6.3 (0.71)	15.8 (1.8)
NT23-010	NT60-010	10:1	163 (7.1)	58 (6.6)	54 (6.1)	52 (5.9)	250 (28.2)	0.14 (0.016)	6.3 (0.71)	15.8 (1.8)
NT23-015	NT60-015	15:1	124 (14.0)	110 (12.4)	105 (11.9)	100 (11.3)	250 (28.3)	0.21 (0.024)	6.3 (0.71)	15.8 (1.8)
NT23-020	NT60-020	20:1	180 (20.3)	147 (16.6)	130 (14.7)	120 (13.6)	275 (31.1)	0.21 (0.024)	6.3 (0.71)	15.8 (1.8)
NT23-025	NT60-025	25:1	175 (9.8)	142 (16.0)	125 (14.1)	115 (13.0)	250 (28.3)	0.21 (0.024)	6.3 (0.71)	15.8 (1.8)
NT23-030	NT60-030	30:1	207 (23.4)	182 (20.6)	157 (17.7)	147 (16.6)	275 (31.1)	0.13 (0.015)	6.3 (0.71)	15.8 (1.8)
NT23-040	NT60-040	40:1	207 (23.4)	182 (20.6)	157 (17.7)	147 (16.6)	275 (31.1)	0.13 (0.015)	6.3 (0.71)	15.8 (1.8)
NT23-050	NT60-050	50:1	202 (22.8)	175 (19.8)	152 (17.2)	142 (16.0)	275 (31.1)	0.13 (0.015)	6.3 (0.71)	15.8 (1.8)
NT23-070	NT60-070	70:1	197 (22.3)	172 (19.4)	147 (16.6)	137 (15.5)	275 (31.1)	0.13 (0.015)	6.3 (0.71)	15.8 (1.8)
NT23-100	NT60-100	100:1	85 (9.6)	79 (8.9)	74 (8.9)	73 (8.2)	275 (31.1)	0.13 (0.015)	6.3 (0.71)	15.8 (1.8)

¹ Ratios are exact, higher ratios are also available, consult factory.
² Rated output torque at rated speed for specific hours of life.

³ Mass moment of inertia reflected to the input shaft (including pinion assembly)

⁴ Allowable planetary peak torque for emergency stop or heavy shock loading.

See page 10 for gearhead selection criteria

Available in 24 hours through the Micron Gearhead Express program

Sold & Serviced By
ELECTROMATE

Toll Free Phone (877) SERV098

Toll Free Fax (877) SERV098

www.electromate.com

sales@electromate.com

MICRON

©2003 Danaher Motion. Printed in the U.S.A. The specifications in this publication are believed to be accurate and reliable. However, it is the responsibility of the product user to determine the suitability of Micron products for a specific application. While defective products will be replaced without charge if promptly returned, no liability is assumed beyond such replacement.

* Trademark of Danaher Motion. DANAHER MOTION is registered in the U.S. Patent and Trademark Office and in other countries.

NemaTRUE* Size 34/90mm True Planetary* Gearheads

NemaTRUE* English

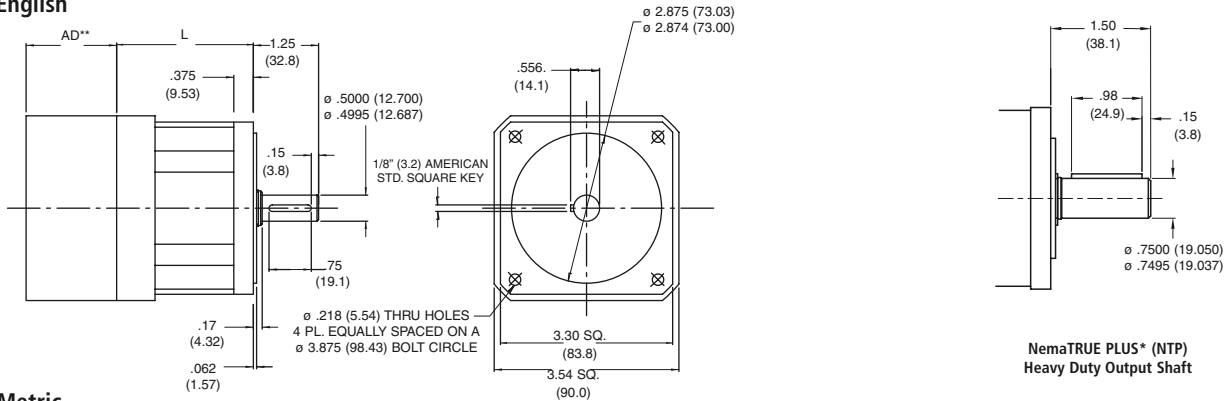

NemaTRUE PLUS* (NTP)
Heavy Duty Output Shaft

NemaTRUE* Metric

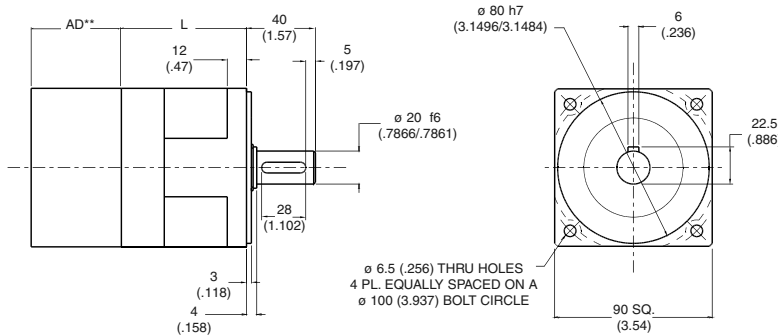

Ratio	NT34 Dimension 'L' in (in)	NT90 Dimension 'L' in (mm)	Backlash (arc-min)		Weight lb (Kg)	Efficiency
			Precision	High Precision		
3:1 to 10:1	2.68 (68.0)	2.63 (66.8)	13 max	8 max	4.2 (1.9)	90%
15:1 to 100:1	3.53 (89.6)	3.53 (89.7)	15 max	9 max	5.6 (2.5)	85%

All dimensions are: mm (inches)
AD** = Adapter length.
Adapter length will vary depending on motor.

(TABLE 1) PERFORMANCE SPECIFICATIONS

Part Number		Ratio ¹	10,000 HOUR LIFE				T _{peak} in-lb (Nm)	J in-lb-sec ² x10 ⁴ (kg-cm ²)	Torsional Stiffness in-lb/arc-min (Nm/arc-min)	
			T _r (1000 rpm) in-lb (Nm)	T _r (2000 rpm) in-lb (Nm)	T _r (3000 rpm) in-lb (Nm)	T _r (4000 rpm) in-lb (Nm)			NT	NTP
NT34-003	NT90-003	3:1	360 (40.7)	320 (36.2)	295 (33.3)	270 (30.5)	510 (57.6)	3.9 (0.44)	16.8 (1.9)	48 (5.4)
NT34-004	NT90-004	4:1	515 (58.2)	425 (48.0)	380 (42.9)	350 (39.6)	700 (79.1)	1.20 (0.140)	16.8 (1.9)	48 (5.4)
NT34-005	NT90-005	5:1	490 (55.4)	400 (45.2)	355 (40.1)	325 (36.7)	700 (79.1)	1.20 (0.140)	16.8 (1.9)	48 (5.4)
NT34-007	NT90-007	7:1	470 (53.1)	380 (42.9)	335 (37.9)	305 (34.5)	700 (79.1)	1.20 (0.140)	16.8 (1.9)	48 (5.4)
NT34-010	NT90-010	10:1	238 (26.9)	212 (24.0)	200 (22.6)	192 (21.7)	700 (79.1)	0.66 (0.075)	16.8 (1.9)	48 (5.4)
NT34-015	NT90-015	15:1	454 (51.3)	416 (47.0)	391 (44.2)	373 (42.1)	850 (96.0)	1.20 (0.140)	16.8 (1.9)	48 (5.4)
NT34-020	NT90-020	20:1	677 (76.5)	620 (70.1)	587 (66.3)	551 (62.3)	850 (96.1)	1.20 (0.140)	16.8 (1.9)	48 (5.4)
NT34-025	NT90-025	25:1	652 (73.7)	595 (67.2)	562 (63.5)	526 (59.4)	850 (96.0)	1.20 (0.140)	16.8 (1.9)	48 (5.4)
NT34-030	NT90-030	30:1	500 (56.5)	454 (51.3)	432 (48.8)	416 (47.0)	850 (96.0)	0.66 (0.075)	16.8 (1.9)	48 (5.4)
NT34-040	NT90-040	40:1	770 (87.0)	702 (79.3)	668 (75.5)	620 (70.1)	850 (96.1)	0.65 (0.074)	16.8 (1.9)	48 (5.4)
NT34-050	NT90-050	50:1	720 (81.4)	652 (73.7)	618 (69.8)	595 (67.2)	850 (96.0)	0.65 (0.074)	16.8 (1.9)	48 (5.4)
NT34-070	NT90-070	70:1	770 (87.0)	702 (79.3)	668 (75.5)	620 (70.1)	850 (96.1)	0.65 (0.074)	16.8 (1.9)	48 (5.4)
NT34-100	NT90-100	100:1	325 (36.7)	295 (33.3)	280 (31.6)	270 (30.5)	700 (79.1)	0.65 (0.074)	16.8 (1.9)	48 (5.4)

¹ Ratios are exact, higher ratios are also available, consult factory.

² Rated output torque at rated speed for specific hours of life.

J = Mass moment of inertia reflected to the input shaft (including pinion assembly)

T_{peak} = Allowable intermittent peak torque for emergency stop or heavy shock loading.

See page 10 for gearhead selection criteria

© 2006 Danaher Motion. Printed in the U.S.A. The specifications in this publication are believed to be accurate and reliable. However, it is the responsibility of the product user to determine the suitability of Micron products for a specific application.

While defective products will be replaced without charge if promptly returned, no liability is assumed beyond such replacement.

* Trademark of Danaher Motion. DANAHER MOTION is registered in the U.S. Patent and Trademark Office and in other countries.

Sold & Serviced By:

ELECTRONATE

Toll Free Phone (877) SERV098

Toll Free Phone (877) SERV099

www.electronate.com

sales@electronate.com

Available in 24 hours through the Micron Gearhead Express program

MICRON

NemaTRUE* Size 42/115mm True Planetary* Gearheads

NemaTRUE* English

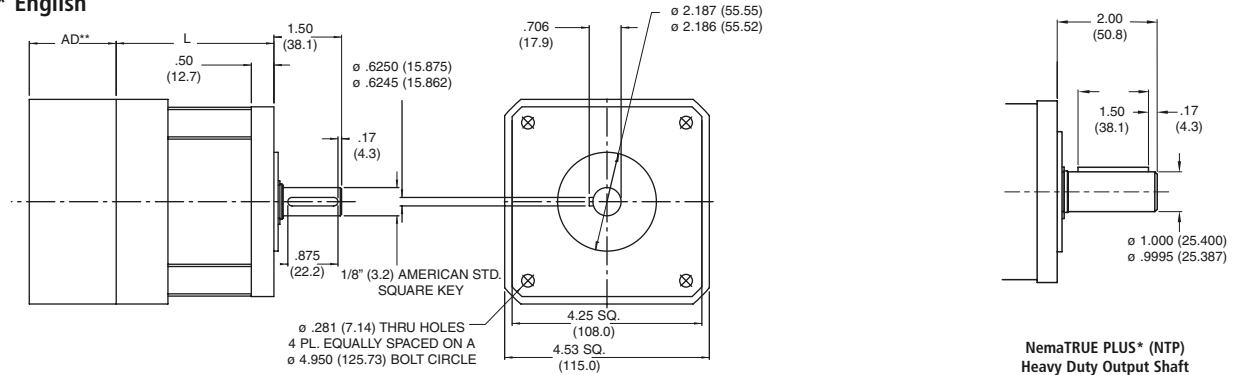

NemaTRUE* Metric

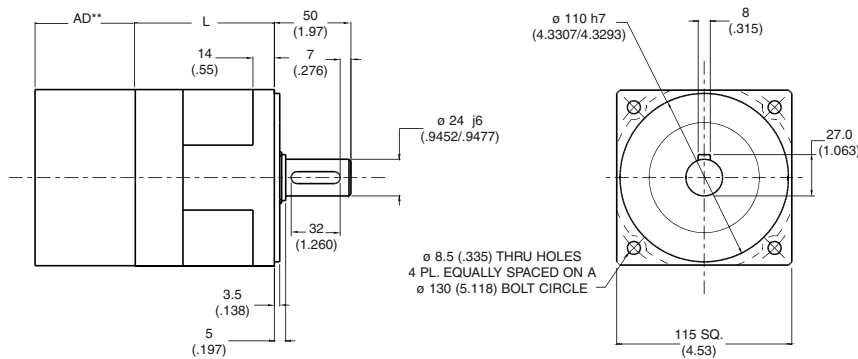

Ratio	NT42 Dimension 'L' in (in)	NT115 Dimension 'L' in (mm)	Backlash (arc-min)		Weight lb (Kg)	Efficiency
			Precision	High Precision		
3:1 to 10:1	3.49 (88.6)	3.46 (87.9)	13 max	8 max	8.9 (4.0)	90%
15:1 to 100:1	4.72 (119.9)	4.69 (119.1)	15 max	9 max	11.7 (5.3)	85%

All dimensions are: mm (inches)
AD** = Adapter length.
Adapter length will vary depending on motor.

(TABLE 1) PERFORMANCE SPECIFICATIONS

Part Number		Ratio ¹	10,000 HOUR LIFE				T _{peak} in-lb (Nm)	J in-lb-sec ² × 10 ⁻⁴ (kg-cm ²)	Torisional Stiffness in-lb/arc-min (Nm/arc-min)	
			T _r (1000 rpm) in-lb (Nm)	T _r (2000 rpm) in-lb (Nm)	T _r (3000 rpm) in-lb (Nm)	T _r (4000 rpm) in-lb (Nm)				
NT42-003	NT115-003	3:1	690 (78.0)	594 (67.1)	530 (59.9)	485 (54.8)	1000 (113.0)	14 (1.6)	31 (3.5)	154 (17.4)
NT42-004	NT115-004	4:1	850 (96.1)	698 (78.9)	622 (70.3)	570 (64.4)	1000 (113.0)	3.80 (0.43)	31 (3.5)	154 (17.4)
NT42-005	NT115-005	5:1	810 (55.4)	400 (45.2)	355 (40.1)	325 (36.7)	1000 (113.0)	3.80 (0.43)	31 (3.5)	154 (17.4)
NT42-007	NT115-007	7:1	790 (89.3)	638 (72.1)	562 (63.5)	510 (57.6)	1000 (113.0)	3.80 (0.43)	31 (3.5)	154 (17.4)
NT42-010	NT115-010	10:1	460 (52.0)	412 (46.6)	388 (43.8)	370 (41.8)	1000 (113.0)	1.9 (0.21)	31 (3.5)	154 (17.4)
NT42-015	NT115-015	15:1	454 (51.3)	416 (47.0)	391 (44.2)	373 (42.1)	1600 (180.8)	3.9 (0.44)	31 (3.5)	154 (17.4)
NT42-020	NT115-020	20:1	1290 (145.8)	1090 (123.2)	985 (111.3)	905 (102.3)	1600 (180.8)	3.70 (0.42)	31 (3.5)	154 (17.4)
NT42-025	NT115-025	25:1	1250 (141.2)	1050 (118.6)	945 (106.8)	865 (97.7)	1600 (180.8)	3.70 (0.42)	31 (3.5)	154 (17.4)
NT42-030	NT115-030	30:1	972 (109.8)	878 (99.2)	842 (95.1)	805 (91.0)	1600 (180.8)	1.9 (0.21)	31 (3.5)	154 (17.4)
NT42-040	NT115-040	40:1	1435 (162.2)	1290 (145.8)	1190 (134.5)	1090 (123.2)	1600 (180.8)	1.80 (0.20)	31 (3.5)	154 (17.4)
NT42-050	NT115-050	50:1	1395 (157.6)	1250 (141.2)	1150 (118.6)	1050 (118.6)	1600 (180.8)	1.80 (0.20)	31 (3.5)	154 (17.4)
NT42-070	NT115-070	70:1	1375 (155.4)	1230 (139.0)	1130 (127.7)	1030 (116.4)	1600 (180.8)	1.80 (0.20)	31 (3.5)	154 (17.4)
NT42-100	NT115-100	100:1	630 (71.2)	575 (65.0)	540 (61.0)	522 (59.0)	1200 (135.6)	1.80 (0.20)	31 (3.5)	154 (17.4)

¹ Ratios are exact, higher ratios are also available, consult factory.
² Rated output torque at rated speed for specific hours of life.

³ Mass moment of inertia reflected to the input shaft (including pinion assembly).
⁴ Allowable momentary peak torque for emergency stop or heavy shock loading.
See page 10 for gearhead selection criteria.

Available in 24 hours through the Micron Gearhead Express program

Sold & Serviced By
ELECTROMATE
Toll Free Phone (877) SERV098
Toll Free Fax (877) SERV098
www.electromate.com
sales@electromate.com

©2003 Danaher Motion. Printed in the U.S.A. The specifications in this publication are believed to be accurate and reliable. However, it is the responsibility of the product user to determine the suitability of Micron products for a specific application. While defective products will be replaced without charge if promptly returned, no liability is assumed beyond such replacement.

Radial and Axial Load Ratings

NT23, NTP23 and NT60

Allowable axial load $F_a = 310 \text{ lb}_f$ (1379N) at 250 rpm

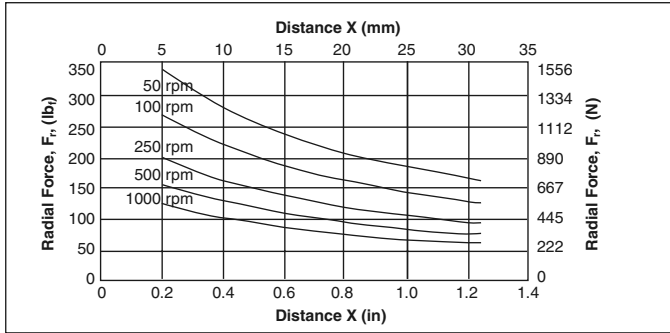
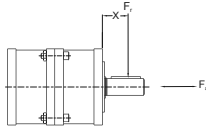

NT34, NTP34 and NT90

Allowable axial load $F_a = 510 \text{ lb}_f$ (2269N) at 250 rpm

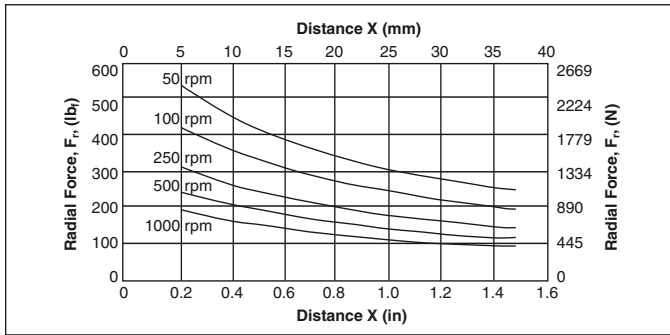
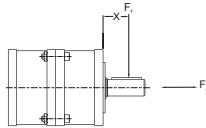

NT42, NTP42 and NT115

Allowable axial load $F_a = 760 \text{ lb}_f$ (3380N) at 250 rpm

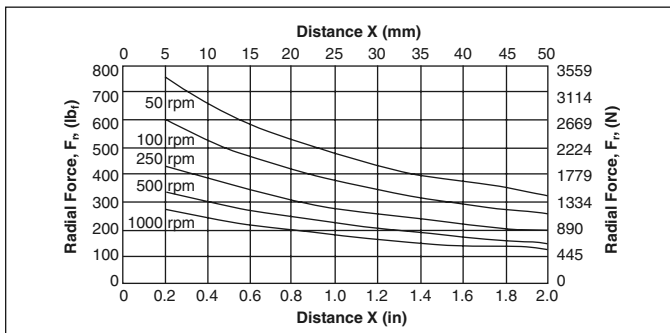
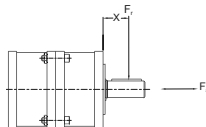

Sold & Serviced By:



These graphs display the allowable radial load at a given distance (X) from the mounting surface based on an MTBF of 10,000 hours for the mean output speed Ω_{out} , as described on page 10.

Toll Free Phone (877) SERV098

Toll Free Fax (877) SERV099

www.electromate.com

sales@electromate.com

© Danaher Motion. Printed in the U.S.A. The specifications in this publication are believed to be accurate and reliable. However, it is the responsibility of the product user to determine the suitability of Micron products for a specific application. Defective products will be replaced without charge if promptly returned, no liability is assumed beyond such replacement.

* Trademark of Danaher Motion. DANAHER MOTION is registered in the U.S. Patent and Trademark Office and in other countries.



Mounting Tools

Micrometer Adjustable Torque Wrench Series



Torque Wrench Ordering Information

To ensure that the proper torque is applied to the gearhead pinion assembly, Danaher Motion offers a complete line of easy to use torque wrenches. To order a torque wrench, ask for the corresponding part number along with your gearhead order.

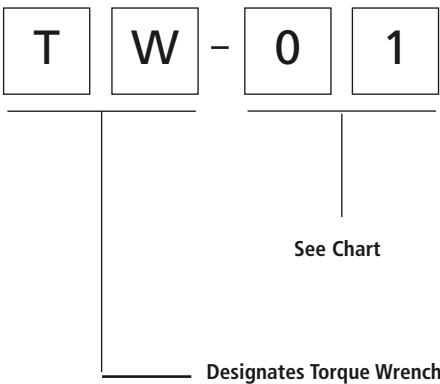

Gearhead Model	Gearhead Frame Size	Torque Wrench Part Number
NemaTRUE*	23 / 60	TW-060
	34 / 90	TW-090
	42 / 115	TW-115
NemaTRUE 90*	23	TW-060
	34	TW-090
	42	TW-115
DuraTRUE* DuraTRUE 90*	60	TW-060
	90	TW-090
	115	TW-115
	142	TW-142
UltraTRUE* UltraTRUE 90*	60	TW-006
	75	TW-075
	90	TW-075
	100	TW-010
	115	TW010
	140	TW-014
	180	TW-018
EverTRUE*	100	TW-010
	140	TW-014
	180	TW-018
EQ*	23 / 60	TW-060

Sold & Serviced By:



Toll Free Phone (877) SERV098

Toll Free Fax (877) SERV099

www.electromate.com

sales@electromate.com

© 2009 Danaher Motion. Printed in the U.S.A. The specifications in this publication are believed to be accurate and reliable. However, it is the responsibility of the product user to determine the suitability of Micron products for a specific application. While defective products will be replaced without charge if promptly returned, no liability is assumed beyond such replacement.



* Trademark of Danaher Motion. DANAHER MOTION is registered in the U.S. Patent and Trademark Office and in other countries.

True Planetary* Gearheads offer. . .

- **High Torque to Size Ratio** - allows compact design
- **Low Backlash** - eliminates positioning errors due to lost motion
- **Inertia Matching** - keeps servo system stable and in control
- **High Rigidity** - optimizes system response
- **Self Re-lubrication** - eliminates costly maintenance and downtime
- **High Radial Load Capacity** - mount pulleys and pinions directly on the output shaft



UltraTRUE* output cage assembly

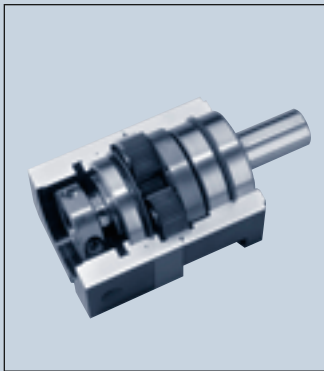

DuraTRUE* in-line planetary gearhead

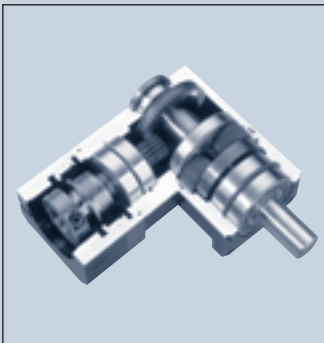

DuraTRUE 90* right angle planetary gearhead

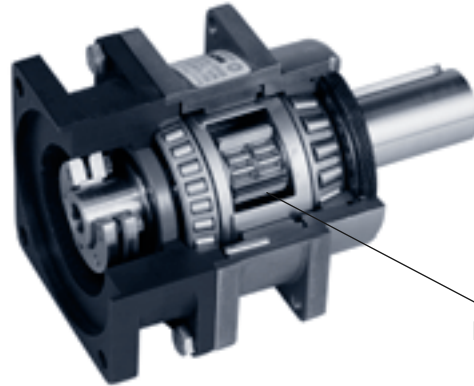

Planetary Gearing

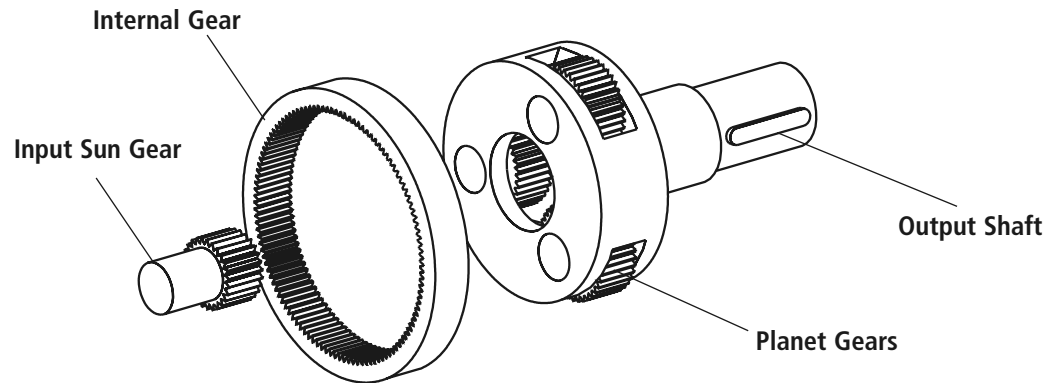

	Gearhead						
Product Feature	NemaTRUE*	NemaTRUE 90*	DuraTRUE*	DuraTRUE 90*	UltraTRUE*	UltraTRUE 90*	EverTRUE*
True Planetary gearing	●	●	●	●	●	●	●

Sold & Serviced By:



Toll Free Phone (877) SERV098

Toll Free Phone (877) SERV099

www.electromate.com

sales@electromate.com

Danaher Motion. Printed in the U.S.A. The specifications in this publication are believed to be accurate and reliable. However, it is the responsibility of the product user to determine the suitability of Micron products for a specific application. While defective products will be replaced without charge if promptly returned, no liability is assumed beyond such replacement.

* Trademark of Danaher Motion. DANAHER MOTION is registered in the U.S. Patent and Trademark Office and in other countries.



Helical Crowned True Planetary* Gearing offers.....

- High Torque Capacity
- Low Backlash
- Smooth Operation
- Greater Load Sharing
- Whisper Quiet



Output housing and helical internal gear are machined from a single piece of high strength steel

Helical gears are known for their quiet and smooth operation along with their ability to transmit higher loads than spur gears. Both of these features of helical gearing result from the improved contact ratio (effective teeth in mesh) over spur gears. Crowning is a modification to the gear tooth profile which optimizes gear mesh alignment. It also enhances distribution of loading on the tooth flank, thereby reducing high stress regions which can result in surface pitting.

Spur vs. Helical Gearing

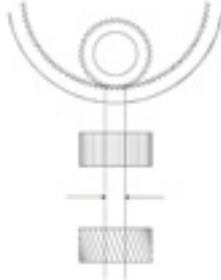

Typical contact ratio is 1.5 for spur gearing.

Contact ratio for equivalent helical gear is 3.3... more than double the contact ratio.

The Contact ratio is defined as the number of teeth in mesh at any given time. The higher the contact ratio, the higher the torque rating of the gearing. Helical gearing has more than 2X the contact ratio of spur gearing.

Crowned vs. Non-crowned

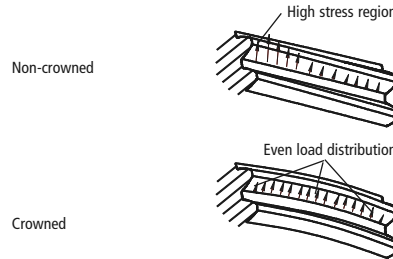

Crowning optimizes the gear mesh alignment within a gear train to increase the torque capacity and reduce noise. It also enhances load distribution on the tooth flank to reduce high stress regions.

UltraTRUE* in-line planetary gearhead

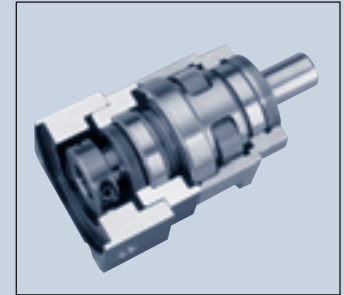

Planetary gearheads are often selected for high precision motion control applications which require a high torque to volume ratio, high torsional stiffness and low backlash. Until now, these attributes have been sufficient to meet the requirements of the market. Danaher Motion has designed a high torque, whisper quiet helical gearhead to meet the recent improvements in servo motor technology.

Danaher Motion engineers accomplished this by combining the positive attributes of gear crowning and helical gearing with the planetary construction to create the smoothest operating gearhead on the market.



UltraTRUE 90* right angle planetary gearhead

Product Feature	Gearhead						
	NemaTRUE*	NemaTRUE 90*	DuraTRUE*	DuraTRUE 90*	UltraTRUE*	UltraTRUE 90*	EverTRUE*
Helical crowned True Planetary gearing					●	●	

Sold & Serviced By:

ELECTROMATE

Toll Free Phone (877) SERV098

Toll Free Fax (877) SERV098

www.electromate.com

sales@electromate.com

*Trademark of Danaher Motion. DANAHER MOTION is registered in the U.S. Patent and Trademark Office and in other countries.

©2003 Danaher Motion. Printed in the U.S.A. The specifications in this publication are believed to be accurate and reliable. However, it is the responsibility of the product user to determine the suitability of Micron products for a specific application. While defective products will be replaced without charge if promptly returned, no liability is assumed beyond such replacement.

PowerTRUE* Right Angle Gearheads offer.....



PowerTRUE* right angle gearset

Right angle gear meshes are typically limited to ratios from 1:1 to 3:1 when using standard bevel gears. Compared to these designs, the PowerTRUE 90 gear increases the ratio range to 5:1.

The key to higher torque density is a unique tooth design, created by complex machining made practical with advanced CNC equipment and software. In the design, multiple teeth in the face gear simultaneously mesh with a standard involute pinion. The continuous tooth engagement yields a high contact ratio between the gear and the pinion, boosting torques to new levels and efficiency to 98%.

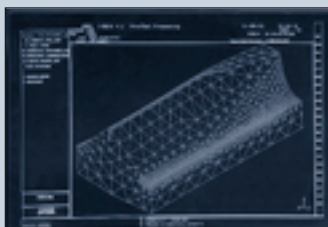

Advanced software enables stress analysis of PowerTRUE tooth profile

- Lower backlash accomplished through single axis mesh adjustment
- A compact right angle design utilizing a high-tech face gear
- Whisper quiet operation due to high contact ratio
- Mesh ratios from 1:1 to 5:1
- 98% efficiency

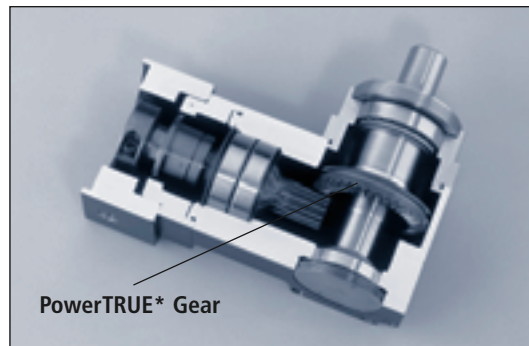

PowerTRUE* Gear



CNC Machining of a PowerTRUE* right angle gear



Computerized mapping of gear tooth profile

	Gearhead					
Product Feature	NemaTRUE*	NemaTRUE 90*	DuraTRUE*	DuraTRUE 90*	UltraTRUE*	EverTRUE*
PowerTRUE gearing	●		●		●	

Sold & Serviced By:

 **ELECTROMATE**

Toll Free Phone (877) SERV098

Toll Free Fax (877) SERV099

www.electromate.com

sales@electromate.com

Danaher Motion. Printed in the U.S.A. The specifications in this publication are believed to be accurate and reliable. However, it is the responsibility of the product user to determine the suitability of Micron products for a specific application. While defective products will be replaced without charge if promptly returned, no liability is assumed beyond such replacement.

*Trademark of Danaher Motion. DANAHER MOTION is registered in the U.S. Patent and Trademark Office and in other countries.

MICRON

RediMount* Motor Mounting System



Exploded view of RediMount mounting system

Mounting Instructions

1- Slide the provided sleeve into the hub and align the slot in the bushing with the slot in the hub.

2- Set the motor on a work surface or hold fixture with the output shaft facing straight up. If there is a key on the motor, remove it and align the keyway with the slot in the hub. Slide the gearhead down onto the motor shaft.

3- Rotate the hub to align the input housing access holes with the hub clamping bolts.

4 - Using a torque wrench tighten the hub bolts to the pre-torque value indicated in the table.

5 - Bolt the motor to the gearhead with the bolts provided.

6 - Gradually tighten the hub bolts in three steps, increasing the torque each time until reaching the final tightening torque in the table.



Close-up view of the bearing system and hub sleeve which accommodates various motor shaft diameters.

- **Self-aligning hub** - Maintains concentricity between motor shaft and gearhead
- **Pre-installed pinion** - Eliminates pinion setting procedure
- **Modular design** - Allows gearhead and input housing to be stocked separately
- **Flexibility** - Allows easy changeover to alternate motors
- **Interchangeability** - Same RediMount system is used throughout 7 product lines

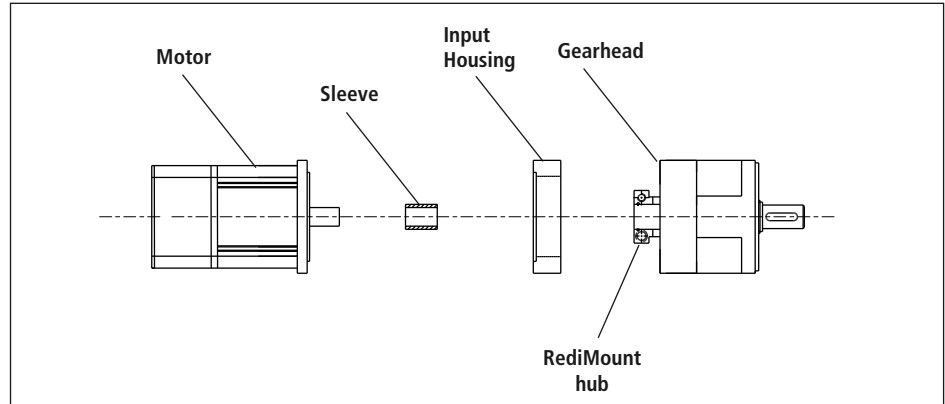

Hub Bolt Tightening Torques					
Gearhead Model	Gearhead Frame Size	Pre-Tightening Torque		Final Tightening Torque	
		in-lb	Nm	in-lb	Nm
NemaTRUE* NemaTRUE 90*	23	2	.2	39	4.4
	34	4	.4	76	8.5
	42	16	1.8	316	36.0
DuraTRUE* DuraTRUE 90*	60	2	.2	39	4.4
	90	4	.4	76	8.5
	115	16	1.8	316	36.0
	142	32	3.6	636	72.0
UltraTRUE* UltraTRUE 90*	60	2	.2	39	4.4
	75/90	4	.4	76	8.5
	10/115	16	1.8	316	36.0
	140	32	3.6	636	72.0
	180	55	6.3	1104	125.0

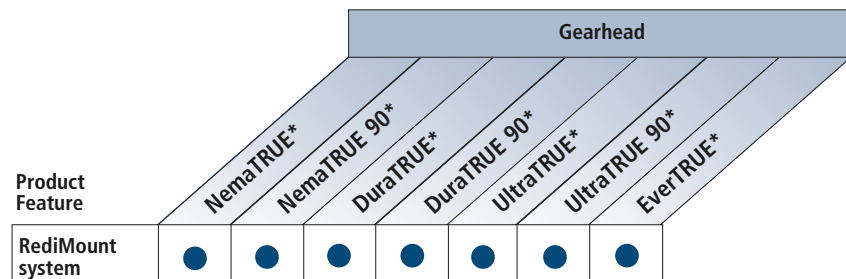

Sold & Serviced By:



Toll Free Phone (877) SERV098

Toll Free Fax (877) SERV098

www.electromate.com

sales@electromate.com



©2003 Danaher Motion. Printed in the U.S.A. The specifications in this publication are believed to be accurate and reliable. However, it is the responsibility of the product user to determine the suitability of Micron products for a specific application. While defective products will be replaced without charge if promptly returned, no liability is assumed beyond such replacement.

*Trademark of Danaher Motion. DANAHER MOTION is registered in the U.S. Patent and Trademark Office and in other countries.

Step 1: Select the required precision class and gearhead configuration (in-line or right angle).

Step 2: Select the proper gearhead using exact or general method.

For continuous duty applications, please contact Applications Engineering.

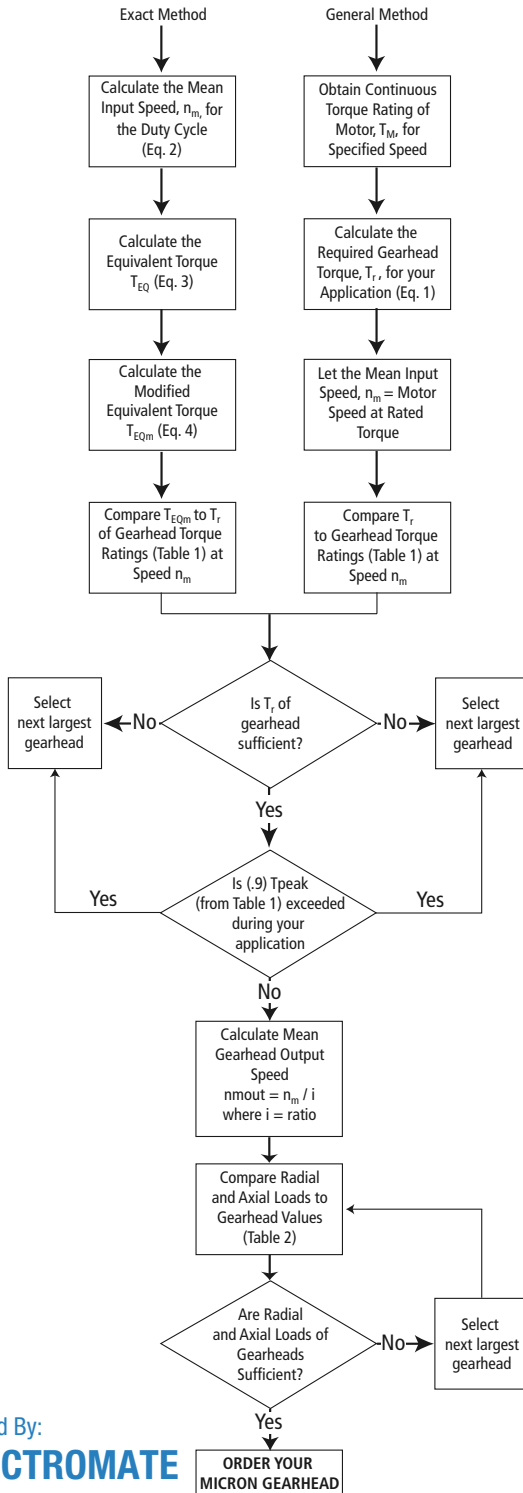

General Method:

Required Gearhead Torque (T_r)

(1) $T_r = T_M \times i \times e$

where: T_M = continuous torque of motor
 i = gearhead ratio
 e = efficiency of gearhead

* Since many motors are capable of exceeding their continuous torque rating for extended lengths of time, the value for T_M will only provide a starting point for gearhead selection. Only use the general method if the continuous motor rating is not exceeded in the application.

Exact Method

Motion Profile

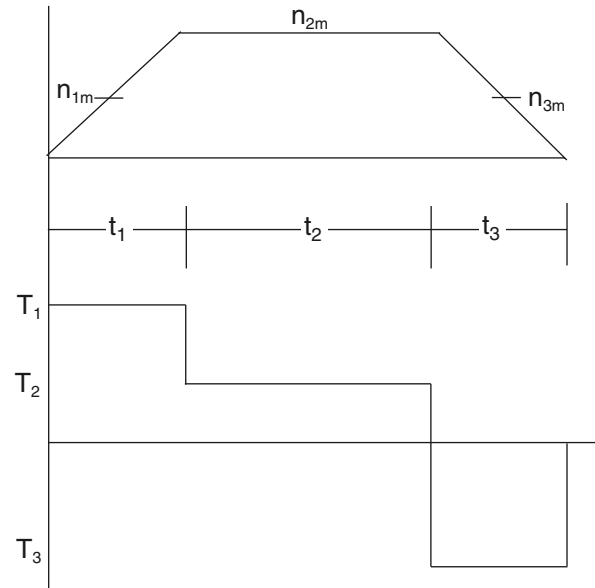

t_n = time period n
 n_{nm} = mean speed during time period t_n
 T_n = torque during time period t_n

Mean input speed (n_m)

(2) $n_m = \frac{n_{1m}t_1 + n_{2m}t_2 + n_{3m}t_3 + \dots + n_{nm}t_n}{t_t}$

where $t_t = t_1 + t_2 + t_3 + \dots + t_n$

Equivalent torque (T_{EQ})

(3) $T_{EQ} = \sqrt[8.7]{T_1^{8.7} \frac{n_{1m}t_1}{n_m t_t} + T_2^{8.7} \frac{n_{2m}t_2}{n_m t_t} + T_3^{8.7} \frac{n_{3m}t_3}{n_m t_t} + \dots + T_n^{8.7} \frac{n_{nm}t_n}{n_m t_t}}$

Modified equivalent torque (T_{EQm})

(4) $T_{EQm} = T_{EQ}^Q$

Q	# of cycles/hr
1	>0
.9	>1000
.7	>2500
.5	>5000

where Q is:

Sold & Serviced By:



Toll Free Phone (877) SERV098

Toll Free Phone (877) SERV099

www.electromate.com

sales@electromate.com

Copyright © Danaher Motion. Printed in the U.S.A. The specifications in this publication are believed to be accurate and reliable. However, it is the responsibility of the product user to determine the suitability of Micron products for a specific application. While defective products will be replaced without charge if promptly returned, no liability is assumed beyond such replacement.

* Trademark of Danaher Motion. DANAHER MOTION is registered in the U.S. Patent and Trademark Office and in other countries.

