

Table Top Robot **TTA Series**



Sold & Serviced By:
ELECTROMATE

Toll Free Phone (877) SERV098
Toll Free Fax (877) SERV099
www.electromate.com
sales@electromate.com

Improved Tabletop Robot for Cell Production Applications, Featuring Significantly Higher Payload, Maximum Speed and Rigidity!



1. Significantly Higher Payload and Maximum Speed

		Conventional model	TTA
Maximum payload (kg)	Work part side (X-axis)	10	20
	Tool side (Z-axis)	2	5
Maximum speed (mm/sec)	X-axis	300	800
	Y-axis	300	800
	Z-axis	300	400

➔ Up to **2.5** times

➔ Up to **2.6** times

2. Stores Much More Programs and Positions

The larger memory lets you store much more programs and positions.

The additional data recovery function makes sure the original data can be restored should writing to a FLASH drive fails due to a power failure.

	Conventional model	TTA
Number of programs	64	255
Number of program steps	6,000	9,999
Number of multi-tasking programs	16	16
Number of display languages	2 (Japanese/English)	2 (Japanese/English)
Number of positions	3,000	30,000 (*1)

➔ **4** times more programs

➔ **10** times more positions

*1: 10,000 points can be backed up in the system memory.

3. Three Times As Many I/O Points As Conventional Models

When the standard I/O slot isn't enough, up to two additional expansion I/O slots can be installed.

Inputs/outputs

16 points/16 points ➔ Up to 48 points/48 points (*)

(*)When the expansion I/O slot (coming soon) is added

3 times more

Supporting field networks

CC-Link

DeviceNet

PROFI BUS

EtherNet/IP
(Coming soon)

1

Sold & Serviced By:
ELECTROMATE

Toll Free Phone (877) SERV098
Toll Free Fax (877) SERV099
www.electromate.com
sales@electromate.com

4. More Variations

Four operating ranges are available to choose from.
 The 3-axis specification is available in two types of Z-axis strokes:
 100mm and 150mm.
 You can select a model ideal for the size of your work part.
 Additional options let you change the Y-axis height and position.
 (Refer to p. 3 for details.)

* You can also custom-order 4-axis robots.

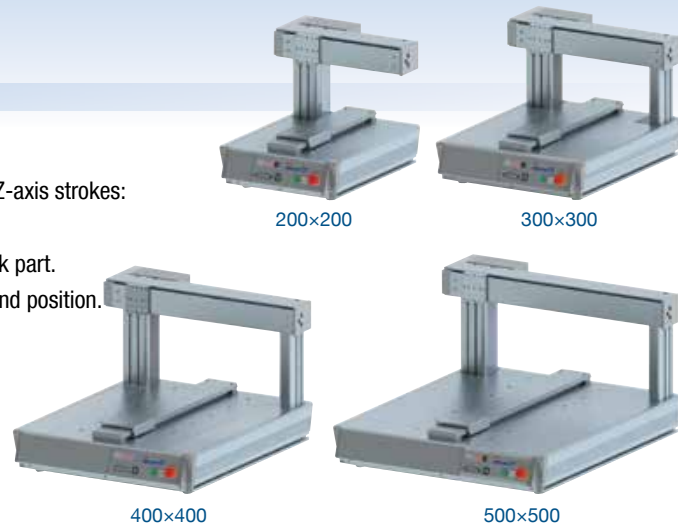

5. Greater Bending Rigidity is Achieved by Integrating the Structure of the Y-axis Base with the Mounting Bracket.

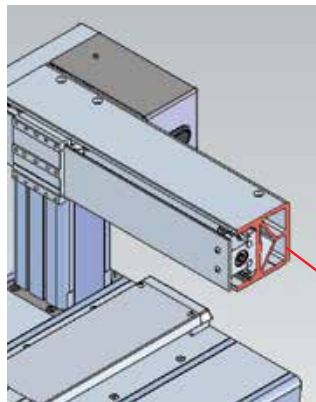
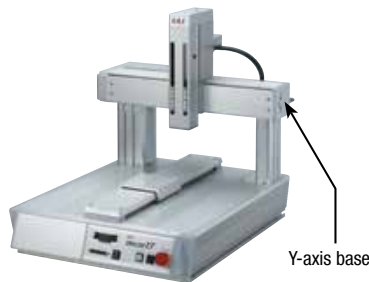

Bending rigidity
 at least **1.5** times
 higher than the
 conventional model

Y-axis base & mounting bracket in one
Integral Structure

6. Labyrinth Structure to Suppress Intrusion of Foreign Matter into X-axis

The X-axis opening is structured as a labyrinth in order to make it difficult for foreign matter dropping onto the actuator (such as screws, molten metal, dust, etc.) to enter the X-axis. This expands the types of work environment supported.

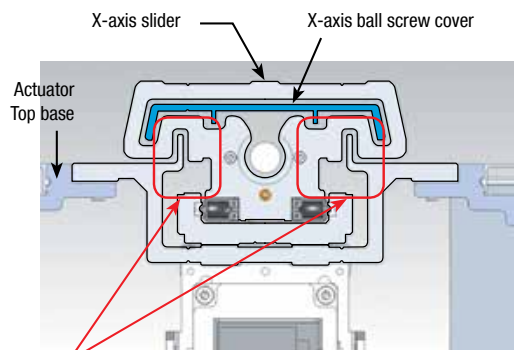

Labyrinth structure

TTA Series Lineup

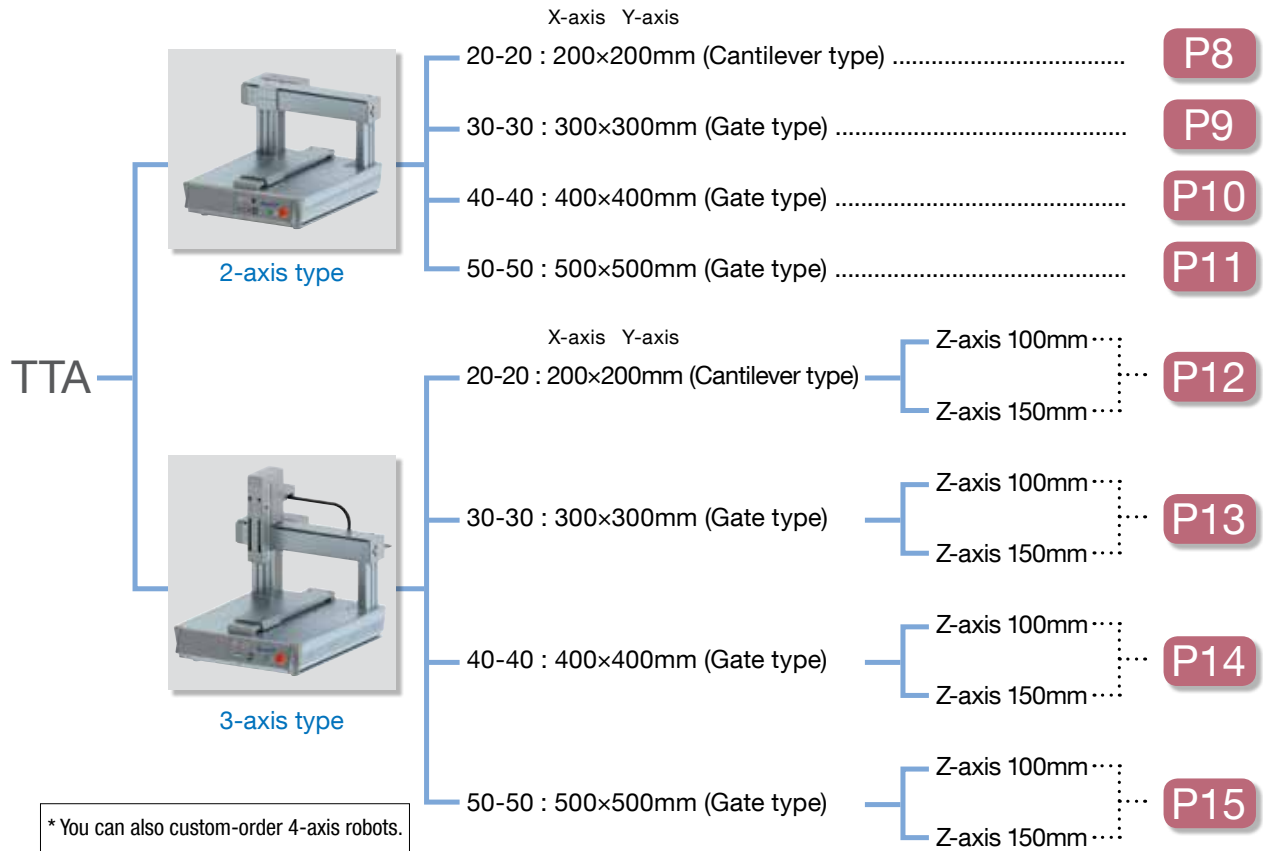

Additional options let you change the support height and horizontal position.

	Standard	Standard + 50mm up	Standard + 100mm up
Y-axis height is selectable	-	H1	H2

	Standard	Standard + 90mm forward	Standard + 180mm forward
Y-axis horizontal position is selectable	-	F1	F2

* To change both the Y-axis height and Y-axis horizontal position, specify the type codes in alphabetical order together with other option codes.
(Example: AP-F1-FT-H2-OS)

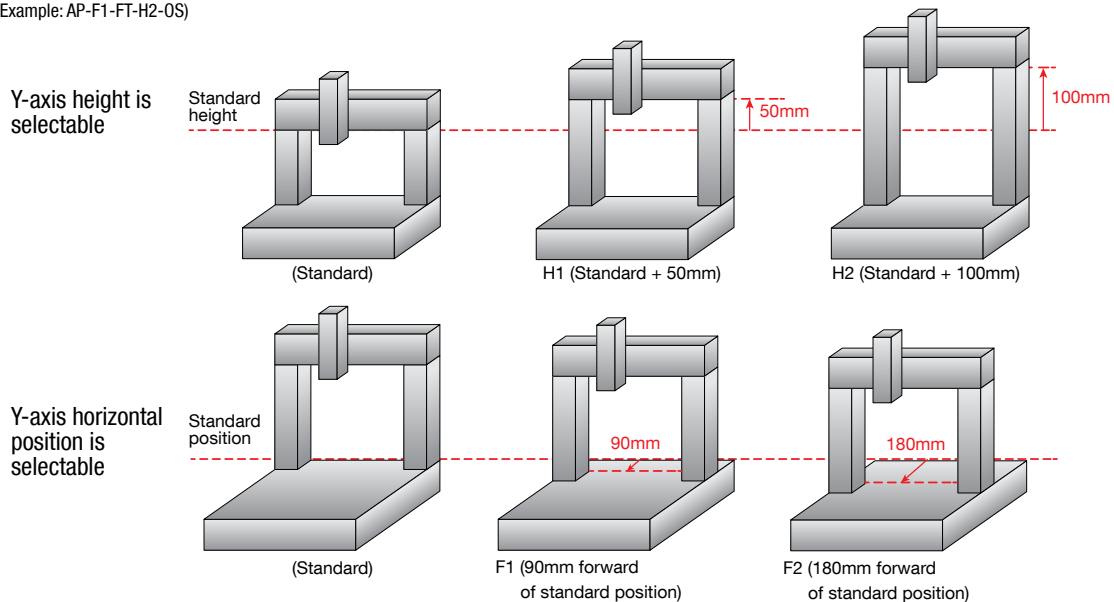

System Configuration

Front Panel Wiring Layout

Teaching Pendant (Option)
Model: TB-01



5m



5m/3m

PC Connection Cable
(Supplied with the PC Software)
Model: CB-ST-E1MW050 (5m)
CB-SEL-USB030 (3m)



PC Software (Option)
Model: IA-101-X-MW
IA-101-TTA-USB
IA-101-X-USBMW

Back Panel Wiring Layout

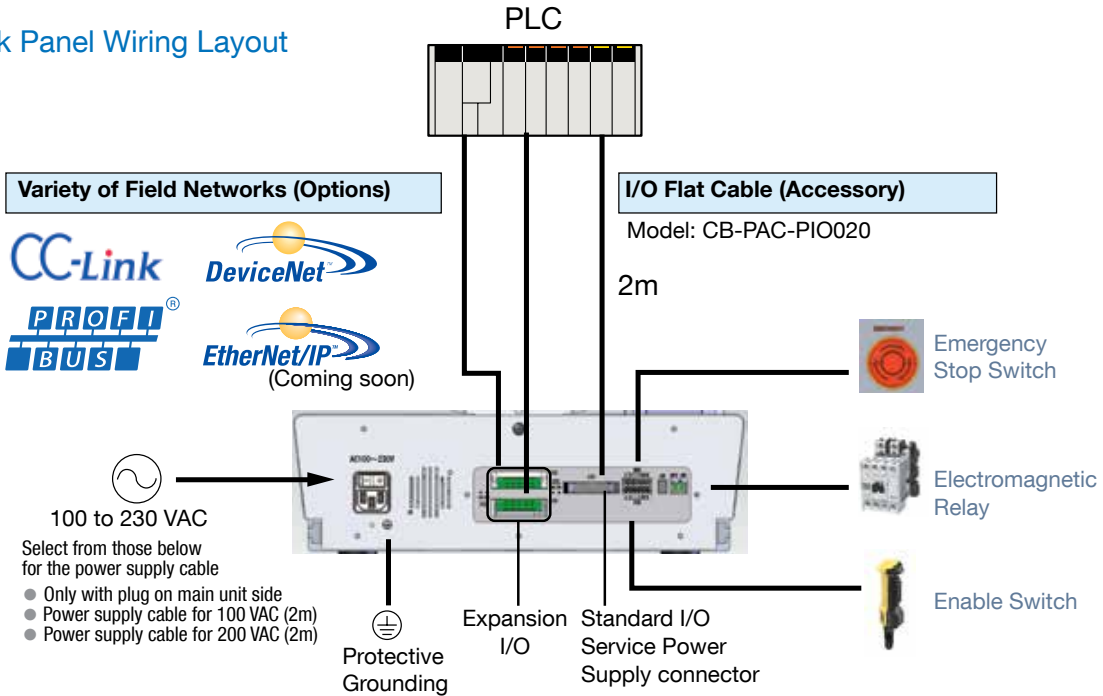

* Emergency stop switch, enable switch, electromagnetic relay, and other external devices may be connected and wired if necessary. If no devices are connected or wired, the robot will still operate properly. Connectors with jumper wires are supplied.

Optional Detachable Operation Console

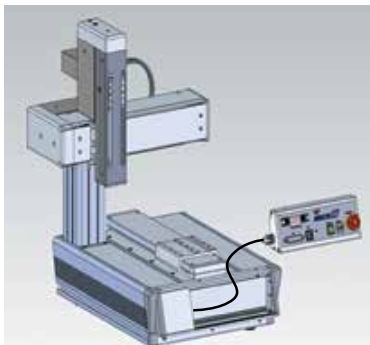

The operation console can be separated from the product for handy operation.
(Cable length: 900mm)

Explanation of Model Name

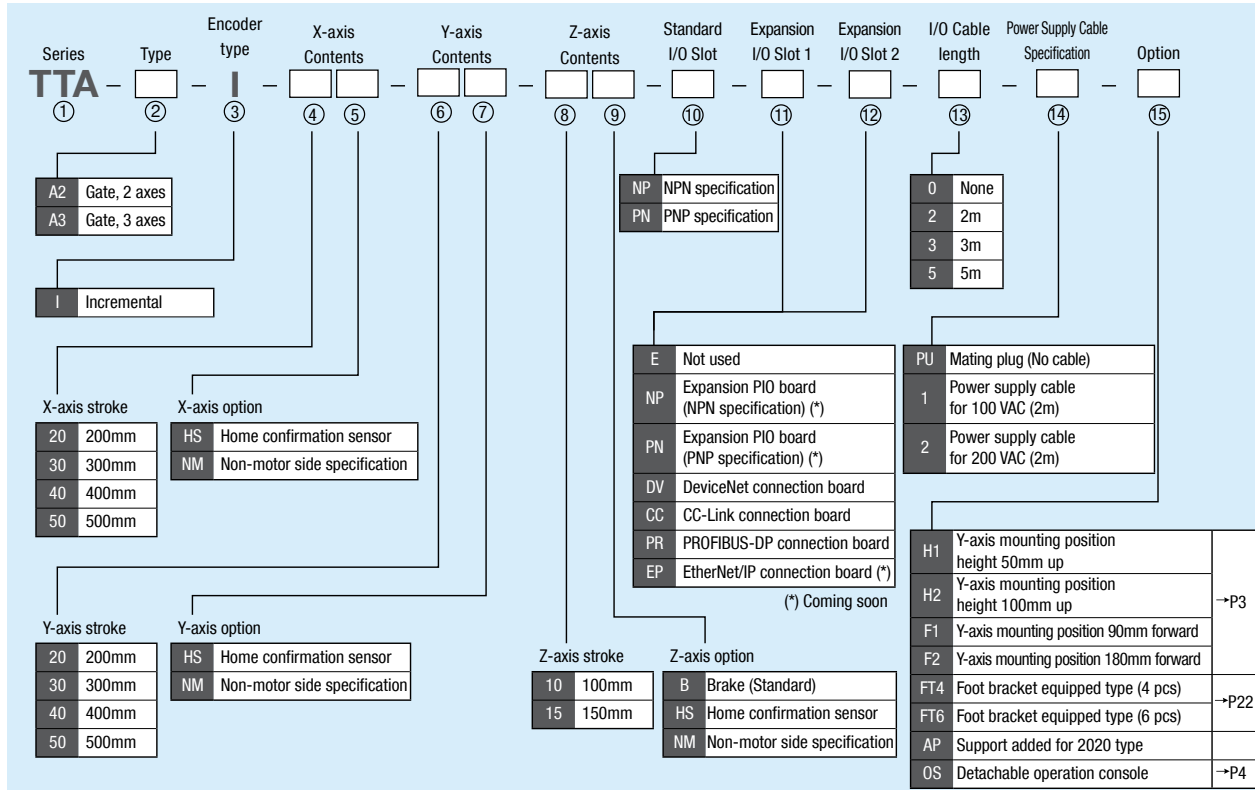

① Series

Name of the series

② Type

Type and number of axes

A2: Gate Type, 2 axes

A3: Gate Type, 3 axes

* The 2020 type is a cantilever type. (The gate type can be selected by specifying the option code [AP].)

③ Encoder type

Type of encoder installed in the actuator

I: Incremental

The slider position data is lost once the power is turned off, which means that home return will be required the next time the power is turned on.

④ X-axis stroke

Stroke of the X-axis

* The X-axis stroke and the Y-axis stroke must be the same.

⑤ X-axis options

The following options are selectable:

HS: Home confirmation sensor

NM: Non-motor side specification

⑥ Y-axis stroke

Stroke of the Y-axis

* The X-axis stroke and the Y-axis stroke must be the same.

⑦ Y-axis options

The following options are selectable:

HS: Home confirmation sensor

NM: Non-motor side specification

⑧ Z-axis stroke

Stroke of the Z-axis

* Two types of 100mm and 150mm are available to choose from.

⑨ Z-axis options

The following options are selectable:

B: Brake (standard accessory)

HS: Home confirmation sensor

NM: Non-motor side specification

⑩ Standard I/O slot

Type of PIO slot installed as standard accessory

NP: Standard PIO (NPN specification)

PN: Standard PIO (PNP specification)

⑪ Expansion I/O slot 1 / ⑫ Expansion I/O slot 2

The following interface boards can be added as options:

E: Not used

NP: Expansion PIO board (NPN specification)

PN: Expansion PIO board (PNP specification)

DV: DeviceNet connection board

CC: CC-Link connection board

PR: PROFIBUS-DP connection board

EP: EtherNet/IP connection board

* The EtherNet/IP connection board can be connected only in expansion slot one. If another board is also used, it is installed in expansion slot 2.

⑬ I/O Cable length

Select the length of the flat cable for the PIO board selected for the standard/expansion slot. (Unit: m)

⑭ Power cable length

Select the type of power cable to be installed.

PU: Mating plug (No cable)

1: Power supply cable for 100 VAC (2m)

2: Power supply cable for 200 VAC (2m)

⑮ Option

AP: Although the standard specification of the 2020 type is "Cantilever," it can be changed to "Gate" type by choosing this option.

5

Sold & Serviced By:

ELECTROMATE

Toll Free Phone (877) SERV098

Toll Free Fax (877) SERV099

www.electromate.com

sales@electromate.com

■ Correlation Diagram of Payload and Speed

All models in the TTA series use pulse motors. Due to the characteristics of the pulse motor, the payload decreases as the speed increases. Use the tables below to check if the desired speed and payload are met.

X-axis

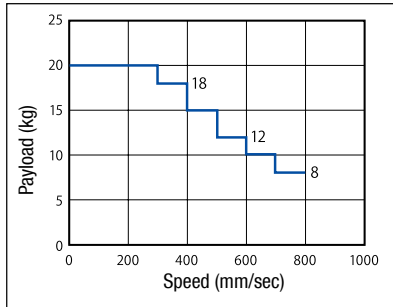

Payload and acceleration/deceleration

Payload	Acceleration/deceleration
20kg	0.2G or less
18kg	0.2G or less
15kg	0.3G or less
12kg	0.3G or less
10kg	0.4G or less
8kg	0.4G or less

Y-axis

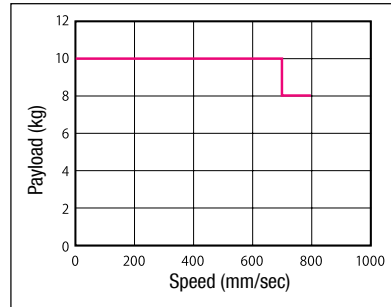

Payload and acceleration/deceleration

Payload	Acceleration/deceleration
10kg	0.4G or less
8kg	0.4G or less

Z-axis

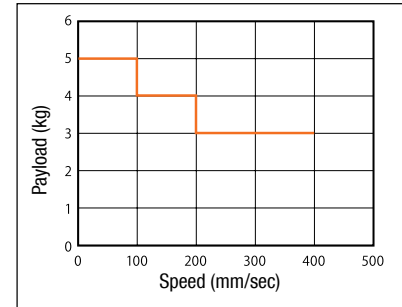

Payload and acceleration/deceleration

Payload	Acceleration/deceleration
5kg	0.2G or less
4kg	0.2G or less
3kg	0.2G or less

■ Correlation Graph of Push Force and Electric Current Limit

In the case of push-motion operation, the push force can be changed freely by changing the electric current limit of the controller.

Z-axis

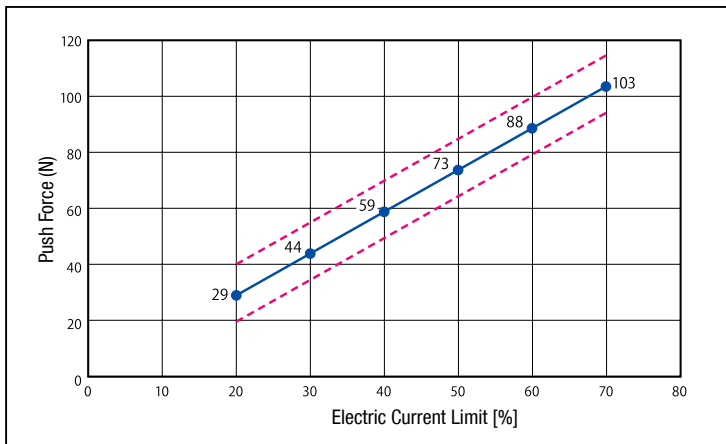

* The push force may vary by $\pm 10\%$ of the maximum push force.

Notes

Notes on Catalog Specifications

Speed

"Speed" refers to the set speed at which the actuator is moved. The slider accelerates from a stationary state. Once the set speed is reached, the slider will move at that speed until immediately before the target position (specified position), where the slider will decelerate to a stop.

Acceleration/Deceleration

"Acceleration" refers to the rate of change of speed from a stationary state until the set speed is reached. "Deceleration" refers to the rate of change of speed from the set speed until the slider stops. Acceleration and deceleration are set in "G" ($0.3G = 2940\text{mm/sec}^2$).

Duty

The tabletop robot can be operated at a duty of 100%.

$$\text{Duty (\%)} = \frac{\text{Operating time}}{\text{Operating time} + \text{Stopped time}} \times 100$$

Positioning repeatability

"Positioning repeatability" refers to the positioning accuracy when the actuator is repeatedly moved to a pre-stored position. It is different from "absolute positioning accuracy."

Home

The home is located on the motor side on the actuator for standard specification, or on the front side of the actuator in the non-motor side specification.

During home return the slider moves until it contacts the mechanical end, and then it reversed its direction. Be careful to prevent contact with surrounding parts.

Dynamic allowable moment (Ma, Mb, Mc)

The load moment is calculated by assuming a travel life of 5,000km. Note that if the specified moment value is exceeded, the service life of the guide will be reduced. The direction of each moment and applicable reference point are shown below:

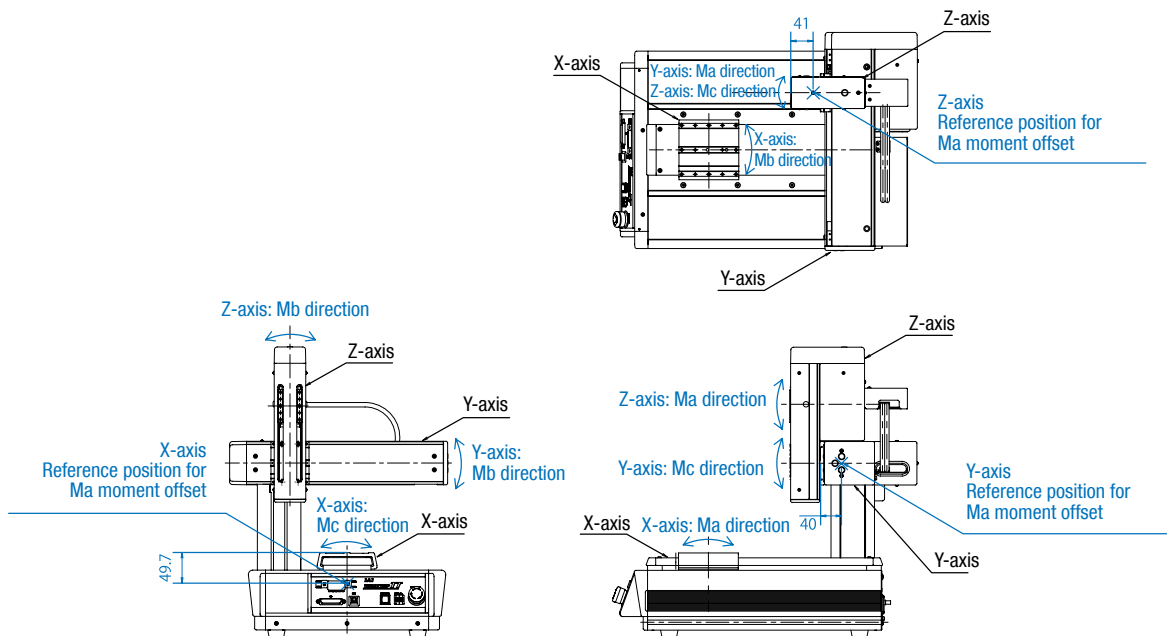

TTA-A2-20-20

Tabletop Robot/Cantilever type 2-axis specification
XY-axes: 200mm



Model Specification Items

Model	TTA - A2 - I - 20	□ - 20	□ - □ - □ - □ - □ - □ - □ - □	□ - □	□	□	□	□	□	□	□	□	□	□	□
Series	Type	Encoder type	X-axis stroke	X-axis option	Y-axis stroke	Y-axis option	Standard I/O Slot	Expansion I/O Slot 1	Expansion I/O Slot 2	I/O Cable length	Power Supply Cable Specification	Option			
A2: 2 axes	I: Incremental (Cantilever) specification	20: 200mm	20: 200mm	HS: Home confirmation sensor NM: Non-motor side specification	NP: NPN specification PN: PNP specification	Refer to the expansion I/O slot table below.	0: None 2.2m 3.3m 5.5m	1: Power supply cable for 100 VAC (2m) 2: Power supply cable for 200 VAC (2m)	Refer to P. 5.						

* If the expansion I/O slot is not used, enter "E".

* Refer to P. 5 for the details of model specification items.

Model/Specifications

Model number	Axis configuration	Encoder type	Motor type	Lead (mm)	Stroke (mm)	Speed (mm/sec)	Payload (kg) (Note 1)
TTA-A2-I-20 ①-②-③-④-⑤-⑥-⑦-⑧	X-axis	Incremental	Pulse motor	16	200	1~800	20
	Y-axis			16	200	1~800	10

* In the above model number, ① and ② indicate the XY-axis options, ③ indicates the standard slot, ④ and ⑤ indicate the expansion slots, ⑥ indicates the I/O cable length, ⑦ indicates the power supply cable specification, and ⑧ indicates the selected option(s).

Expansion I/O Slot

Name	Model	Reference page
Not used	E	-
Expansion PIO board (NPN specification)*	NP	-
Expansion PIO board (PNP specification)*	PN	-
DeviceNet connection board	DV	-
CC-Link connection board	CC	-
PROFIBUS-DP connection board	PR	-
EtherNet/IP connection board*	EP	-

* Coming soon

Common specifications

Drive system	Ball screw (ø12mm, rolled C10) Speed increased at 1.5:1 using a timing belt
Positioning repeatability	±0.02mm (Note 2)
Lost motion	0.1mm or less
Guide	Ball-circulation type linear guide
Dynamic allowable moment (Note 3)	X-axis: Ma: 15.9 N·m Mb: 15.9 N·m Mc: 32.0 N·m Y-axis: Ma: 12.6 N·m Mb: 12.6 N·m Mc: 37.4 N·m
Ambient temperature/humidity	0 to 40°C, 85% RH max. (non-condensing)
Actuator weight	24kg

Dimensions

* During home return, the slider moves to the ME, so be careful to prevent contact with surrounding parts.

SE: Stroke end
ME: Mechanical end

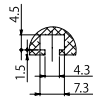

Profile of T-Groove on the Frame

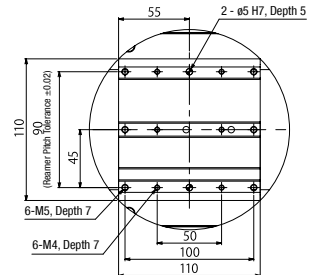
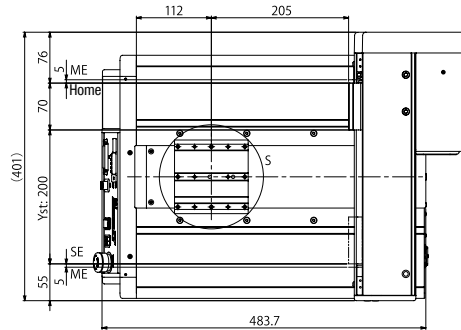

Detail Diagram S (Detail of X-axis Slider)

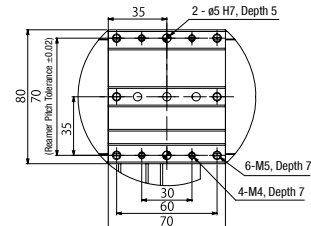

Detail Diagram U (Detail of Y-axis Slider)

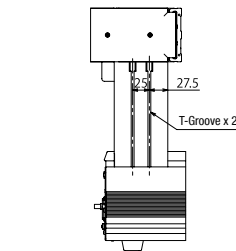
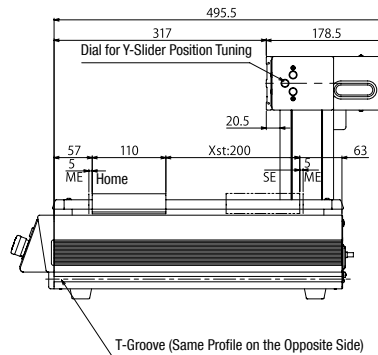
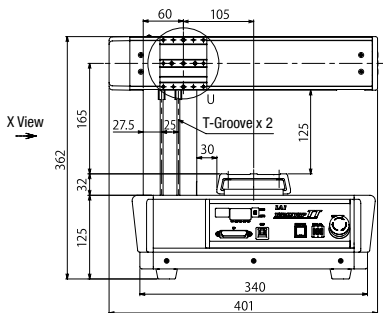

X View (T-Groove on the Side of the Main Unit)

Applicable Controller Specifications

Applicable controller	Maximum number of controlled axes	Compatible encoder type	Program operation	Power-supply voltage	Page
Built-in	2 axes	Incremental	Program	AC100V AC200V	→ P16



Caution

(Note 1) The maximum speed cannot be achieved based on the maximum payload setting. The payload decreases when the speed is increased. Also note that the maximum acceleration/deceleration varies depending on the payload. (Refer to P. 6.)

(Note 2) It is limited to when the actuator temperature is constant. It does not guarantee the absolute accuracy.

(Note 3) The dynamic allowable moment is a value of each axis assuming a traveling life of 5,000km. (Refer to P. 7 for the dynamic allowable moment.)

TTA-A2-30-30

Tabletop Robot/Gate type 2-axis specification
XY-axes: 300mm



Model Specification Items	Series	Type	Encoder type	X-axis stroke	X-axis option	Y-axis stroke	Y-axis option	Standard Slot	Expansion Slot 1	Expansion I/O Slot 2	I/O Cable length	Power Supply Cable Specification	Option
	TTA	A2	I	30	30	30	300mm						
	A2: 2 axes (Gate) I: Incremental specification 30: 300mm 30: 300mm NP: NPN specification PN: PNP specification I/O Slot 1: Refer to the expansion I/O slot table below. I/O Slot 2: Refer to the expansion I/O slot table below. 0: None 2.2m: 1: Power supply cable for 100 VAC (2m) 5.5m: 2: Power supply cable for 200 VAC (2m) PU: Mating plug (No cable) 1: Power supply cable for 100 VAC (2m) 2: Power supply cable for 200 VAC (2m) HS: Home confirmation sensor NM: Non-motor side specification * If the expansion I/O slot is not used, enter "E." Refer to P.5.												

* Refer to P. 5 for the details of model specification items.

Model/Specifications

Model number	Axis configuration	Encoder type	Motor type	Lead (mm)	Stroke (mm)	Speed (mm/sec)	Payload (kg) (Note 1)
TTA-A2-I-30 ①-②-③-④-⑤-⑥-⑦-⑧	X-axis Y-axis	Incremental	Pulse motor	16 16	300 300	1-800 1-800	20 10

* In the above model number, ① and ② indicate the XY-axis options, ③ indicates the standard slot, ④ and ⑤ indicate the expansion slots, ⑥ indicates the I/O cable length, ⑦ indicates the power supply cable specification, and ⑧ indicates the selected option(s).

Expansion I/O Slot

Name	Model	Reference page
Not used	E	-
Expansion PIO board (NPN specification)*	NP	-
Expansion PIO board (PNP specification)*	PN	-
DeviceNet connection board	DV	-
CC-Link connection board	CC	-
PROFIBUS-DP connection board	PR	-
EtherNet/IP connection board*	EP	-

* Coming soon

Common specifications

Drive system	Ball screw (ø12mm, rolled C10) Speed increased at 1.5:1 using a timing belt
Positioning repeatability	±0.02mm (Note 2)
Lost motion	0.1mm or less
Guide	Ball-circulation type linear guide
Dynamic allowable moment (Note 3)	X-axis: Ma: 15.9 N·m Mb: 15.9 N·m Mc: 32.0 N·m Y-axis: Ma: 12.6 N·m Mb: 12.6 N·m Mc: 37.4 N·m
Ambient temperature/humidity	0 to 40°C, 85% RH max.(non-condensing)
Actuator weight	31kg

Dimensions

* During home return, the slider moves to the ME, so be careful to prevent contact with surrounding parts.

SE: Stroke end
ME: Mechanical end



Profile of T-Groove on the Frame

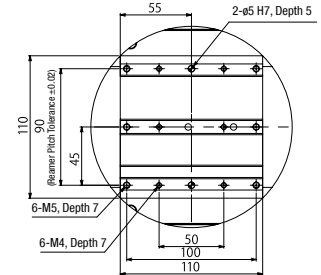
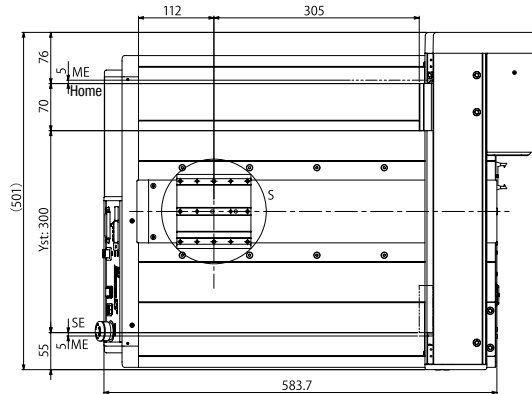

Detail Diagram S (Detail of X-axis Slider)

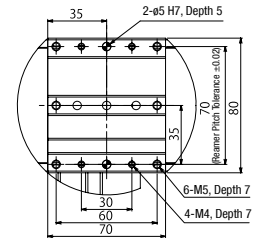

Detail Diagram U (Detail of Y-axis Slider)

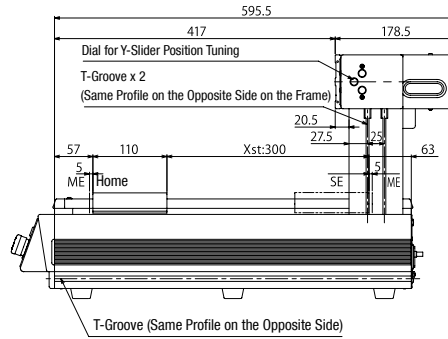
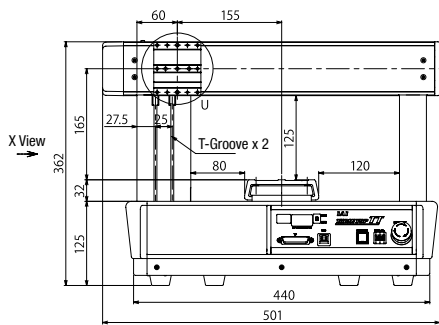

X View (T-Groove on the Side of the Main Unit)

Applicable Controller Specifications

Applicable controller	Maximum number of controlled axes	Compatible encoder type	Program operation	Power-supply voltage	Page
Built-in	2 axes	Incremental	Program	AC100V AC200V	→ P16

Caution

(Note 1) The maximum speed cannot be achieved based on the maximum payload setting. The payload decreases when the speed is increased. Also note that the maximum acceleration/deceleration varies depending on the payload. (Refer to P. 6.)

(Note 2) It is limited to when the actuator temperature is constant. It does not guarantee the absolute accuracy.

(Note 3) The dynamic allowable moment is a value of each axis assuming a traveling life of 5,000km. (Refer to P. 7 for the dynamic allowable moment.)

9 TTA-A2-30-30

TTA-A2-40-40

Tabletop Robot/Gate type 2-axis specification
XY-axes: 400mm



Model Specification Items

Model	TTA - A2 - I - 40	□ - 40	□ - □ - □ - □ - □ - □ - □ - □ - □	□ - □ - □ - □
Series	A2	40	Standard I/O Slot	Expansion I/O Slot 1
Type	I	40	Expansion I/O Slot 2	I/O Cable length
Encoder type	I: Incremental specification	40: 400mm	NP: NPN specification	0: None
X-axis stroke	40: 400mm	40: 400mm	PN: PNP specification	2.2m
X-axis option		HS: Home confirmation sensor	Refer to the expansion I/O slot table below.	3.3m
Y-axis stroke		NM: Non-motor side specification		5.5m
Y-axis option				
Standard I/O Slot				
Expansion I/O Slot 1				
Expansion I/O Slot 2				
I/O Cable length				
Power Supply Cable Specification				
Option				

* Refer to P. 5 for the details of model specification items.

Model/Specifications

Model number	Axis configuration	Encoder type	Motor type	Lead (mm)	Stroke (mm)	Speed (mm/sec)	Payload (kg) (Note 1)
TTA-A2-I-40 ①-④②-③-④-⑤-⑥-⑦-⑧	X-axis	Incremental	Pulse motor	16	400	1-800	20
	Y-axis			16	400	1-800	10

* In the above model number, ① and ② indicate the XY-axis options, ③ indicates the standard slot, ④ and ⑤ indicate the expansion slots, ⑥ indicates the I/O cable length, ⑦ indicates the power supply cable specification, and ⑧ indicates the selected option(s).

Expansion I/O Slot

Name	Model	Reference page
Not used	E	-
Expansion PIO board (NPN specification)*	NP	-
Expansion PIO board (PNP specification)*	PN	-
DeviceNet connection board	DV	-
CC-Link connection board	CC	-
PROFIBUS-DP connection board	PR	-
EtherNet/IP connection board*	EP	-

* Coming soon

Common specifications

Drive system	Ball screw (φ12mm, rolled C10) Speed increased at 1.5:1 using a timing belt
Positioning repeatability	±0.02mm (Note 2)
Lost motion	0.1mm or less
Guide	Ball-circulation type linear guide
Dynamic allowable moment (Note 3)	X-axis: Ma: 15.9 N·m Mb: 15.9 N·m Mc: 32.0 N·m Y-axis: Ma: 12.6 N·m Mb: 12.6 N·m Mc: 37.4 N·m
Ambient temperature/humidity	0 to 40°C, 85% RH max.(non-condensing)
Actuator weight	37kg

Dimensions

You can download CAD drawings from our website.



* During home return, the slider moves to the ME, so be careful to prevent contact with surrounding parts.

SE: Stroke end
ME: Mechanical end

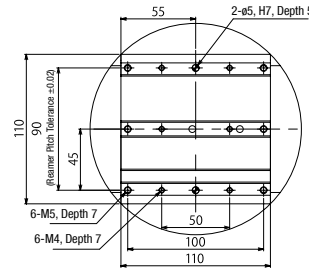
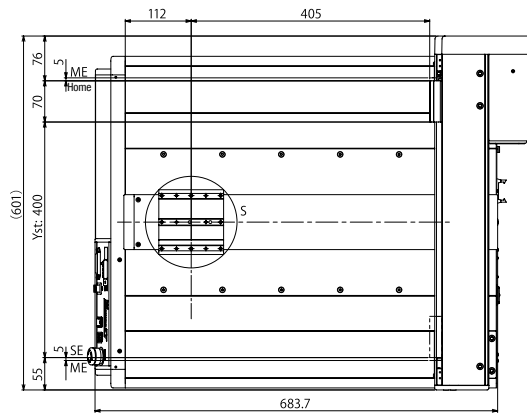
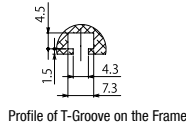

Detail Diagram S (Detail of X-axis Slider)

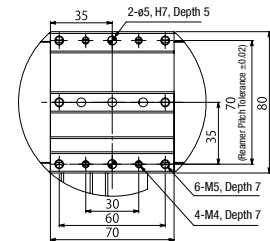

Detail Diagram U (Detail of Y-axis Slider)

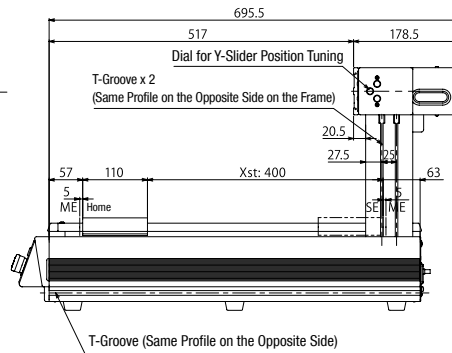
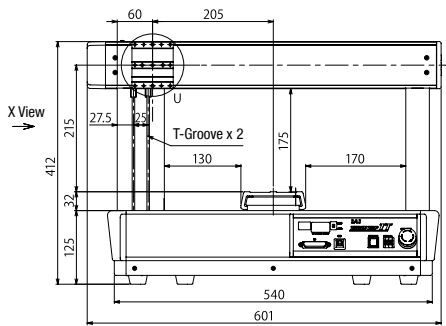

X View (T-Groove on the Side of the Main Unit)

Applicable Controller Specifications

Applicable controller	Maximum number of controlled axes	Compatible encoder type	Program operation	Power-supply voltage	Page
Built-in	2 axes	Incremental	Program	AC100V AC200V	→ P16



Caution

(Note 1) The maximum speed cannot be achieved based on the maximum payload setting. The payload decreases when the speed is increased. Also note that the maximum acceleration/deceleration varies depending on the payload. (Refer to P. 6.)

(Note 2) It is limited to when the actuator temperature is constant. It does not guarantee the absolute accuracy.

(Note 3) The dynamic allowable moment is a value of each axis assuming a traveling life of 5,000km. (Refer to P. 7 for the dynamic allowable moment.)

TTA-A2-40-40

10

Sold & Serviced By:

ELECTROMATE

Toll Free Phone (877) SERV098

Toll Free Fax (877) SERV099

www.electromate.com

sales@electromate.com

TTA-A2-50-50

Tabletop Robot/Gate type 2-axis specification
XY-axes: 500mm



Model Specification Items	TTA - A2 - I - 50	50	50											
Series	Type	Encoder type	X-axis stroke	X-axis option	Y-axis stroke	Y-axis option	Standard I/O Slot	Expansion I/O Slot 1	Expansion I/O Slot 2	I/O Cable length	Power Supply Cable Specification			Option
A2: 2 axes (Gate)	I: Incremental specification		50: 500mm		50: 500mm		NP: NPN specification PN: PNP specification			0: None 2: 2m 3: 3m 5: 5m	1: Power supply cable for 100 VAC (2m) 2: Power supply cable for 200 VAC (2m)			Refer to P. 5.

* Refer to P. 5 for the details of model specification items.

* If the expansion I/O slot is not used, enter "E".

Model/Specifications

Model number	Axis configuration	Encoder type	Motor type	Lead (mm)	Stroke (mm)	Speed (mm/sec)	Payload (kg) (Note 1)
TTA-A2-I-50 ①-② ③-④-⑤-⑥-⑦-⑧	X-axis Y-axis	Incremental	Pulse motor	16 16	500 500	1-800 1-800	20 10

* In the above model number, ① and ② indicate the XY-axis options, ③ indicates the standard slot, ④ and ⑤ indicate the expansion slots, ⑥ indicates the I/O cable length, ⑦ indicates the power supply cable specification, and ⑧ indicates the selected option(s).

Expansion I/O Slot

Name	Model	Reference page
Not used	E	-
Expansion PIO board (NPN specification)*	NP	-
Expansion PIO board (PNP specification)*	PN	-
DeviceNet connection board	DV	-
CC-Link connection board	CC	-
PROFIBUS-DP connection board	PR	-
EtherNet/IP connection board*	EP	-

* Coming soon

Common specifications

Drive system	Ball screw (ø12mm, rolled C10) Speed increased at 1.5:1 using a timing belt
Positioning repeatability	±0.02mm (Note 2)
Lost motion	0.1mm or less
Guide	Ball-circulation type linear guide
Dynamic allowable moment (Note 3)	X-axis: Ma: 15.9 N-m Mb: 15.9 N-m Mc: 32.0 N-m Y-axis: Ma: 12.6 N-m Mb: 12.6 N-m Mc: 37.4 N-m
Ambient temperature/humidity	0 to 40°C, 85% RH max.(non-condensing)
Actuator weight	44kg

Dimensions

* During home return, the slider moves to the ME, so be careful to prevent contact with surrounding parts.

SE: Stroke end
ME: Mechanical end

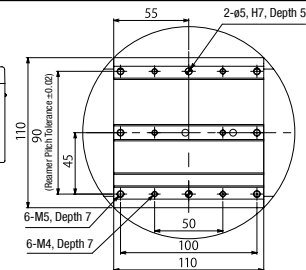
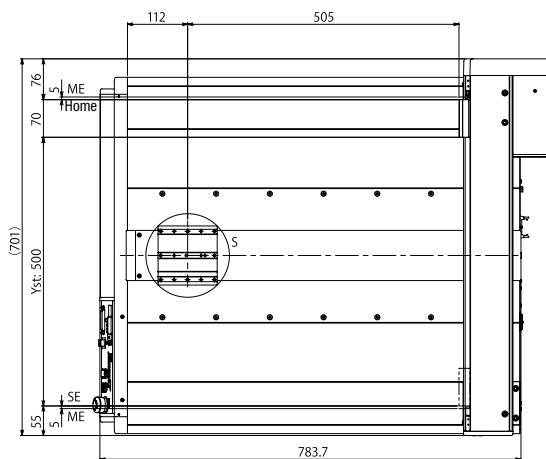
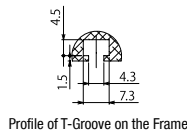

Detail Diagram S (Detail of X-axis Slider)

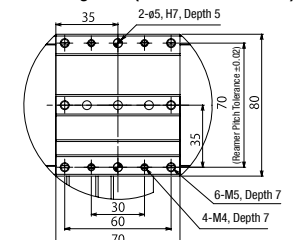

Detail Diagram U (Detail of Y-axis Slider)

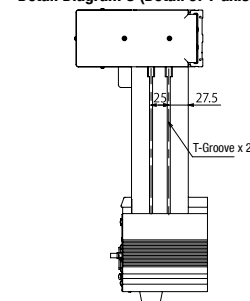
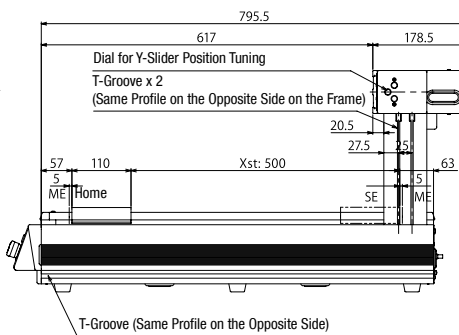
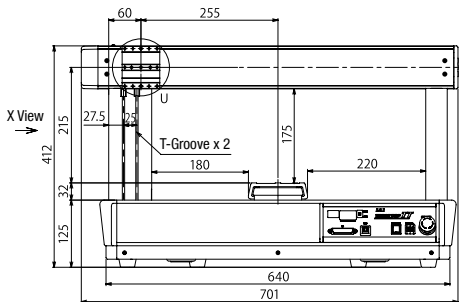

X View (T-Groove on the Side of the Main Unit)

Applicable Controller Specifications

Applicable controller	Maximum number of controlled axes	Compatible encoder type	Program operation	Power-supply voltage	Page
Built-in	2 axes	Incremental	Program	AC100V AC200V	→ P16

Caution

(Note 1) The maximum speed cannot be achieved based on the maximum payload setting. The payload decreases when the speed is increased. Also note that the maximum acceleration/deceleration varies depending on the payload. (Refer to P. 6.)

(Note 2) It is limited to when the actuator temperature is constant. It does not guarantee the absolute accuracy.

(Note 3) The dynamic allowable moment is a value of each axis assuming a traveling life of 5,000km. (Refer to P. 7 for the dynamic allowable moment.)

TTA-A3-20-20

Tabletop Robot/Cantilever type 3-axis specification
XY-axes: 200mm, Z-axis: 100mm/150mm



Model Specification Items	TTA - A3 - I - 20	□ - 20	□ - □	□ - □	□ - □	□ - □	□ - □	□ - □	□ - □	□ - □	□ - □	□ - □	□ - □	□ - □	□ - □	□ - □	□ - □
	Series	Type	Encoder type	X-axis stroke	X-axis option	Y-axis stroke	Y-axis option	Z-axis stroke	Z-axis option	Standard I/O Slot	Expansion I/O Slot 1	Expansion I/O Slot 2	I/O Cable length	Power Supply Cable Specification	Option		
	A3: 3-axis I: Incremental (Cantilever) specification	20: 200mm	20: 200mm	HS: Home confirmation sensor NM: Non-motor side specification	10: 100mm 15: 150mm	NP: NPN specification PN: PNP specification	Refer to the expansion I/O slot table below. * If the expansion I/O slot is not used, enter "E".	0: None 2: 2m 3: 3m 5: 5m	1: Power supply cable for 100 VAC (2m) 2: Power supply cable for 200 VAC (2m)	Refer to P.5.							

* Refer to P.5 for the details of model specification items.

Model/Specifications

Model number	Axis configuration	Encoder type	Motor type	Lead (mm)	Stroke (mm)	Speed (mm/sec)	Payload (kg) (Note 1)
TTA-A3-I-20 ①-② ③B ④-⑤ ⑥-⑦ ⑧-⑨ ⑩	X-axis	Incremental	Pulse motor	16	200	1~800	20
	Y-axis			16	200	1~800	-
	Z-axis			12	100/150	1~400	5

* In the above model number, ① and ② indicate the XY-axis options, ③ indicates the Z-axis stroke, ④ indicates the Z-axis option(s), ⑤ indicates the standard slot, ⑥ and ⑦ indicate the expansion slots, ⑧ indicates the I/O cable length, ⑨ indicates the power supply cable specification, and ⑩ indicates the selected option(s).

Expansion I/O Slot

Name	Model	Reference page
Not used	E	-
Expansion PIO board (NPN specification)*	NP	-
Expansion PIO board (PNP specification)*	PN	-
DeviceNet connection board	DV	-
CC-Link connection board	CC	-
PROFIBUS-DP connection board	PR	-
EtherNet/IP connection board*	EP	-

* Coming soon

Common specifications

Drive system	X/Y/Z-axis ball screw (X/Y-axis: ϕ 12mm, Z-axis: ϕ 10mm, rolled C10) X-axis and Y-axis speeds increased at 1.5:1 using a timing belt
Positioning repeatability	\pm 0.02mm (Note 2)
Lost motion	0.1mm or less
Guide	Ball-circulation type linear guide
Dynamic allowable moment (Note 3)	X-axis: Ma: 15.9 N·m Mb: 15.9 N·m Mc: 32.0 N·m Z-axis: Ma: 9.7 N·m Mb: 9.7 N·m Mc: 20.5 N·m
Ambient temperature/humidity	0 to 40°C, 85% RH max.(non-condensing)
Actuator weight	27kg

Dimensions

* During home return, the slider moves to the ME, so be careful to prevent contact with surrounding parts.

SE: Stroke end
ME: Mechanical end

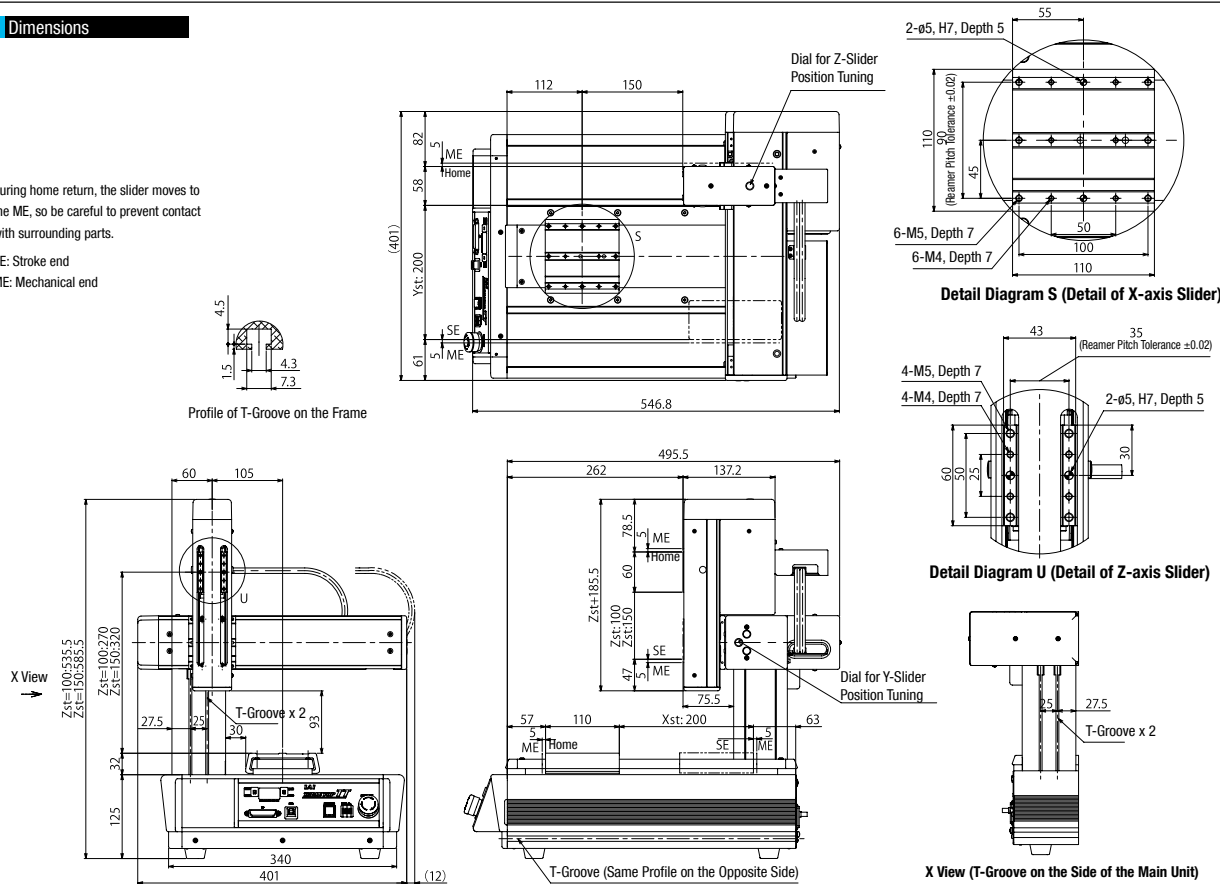

Applicable Controller Specifications

Applicable controller	Maximum number of controlled axes	Compatible encoder type	Program operation	Power-supply voltage	Page
Built-in	3 axes	Incremental	Program	AC100V AC200V	→ P16



Caution

(Note 1) The maximum speed cannot be achieved based on the maximum payload setting. The payload decreases when the speed is increased. Also note that the maximum acceleration/deceleration varies depending on the payload. (Refer to P.6.)

(Note 2) It is limited to when the actuator temperature is constant. It does not guarantee the absolute accuracy.

(Note 3) The dynamic allowable moment is a value of each axis assuming a traveling life of 5,000km. (Refer to P.7 for the dynamic allowable moment.)

TTA-A3-20-20

12

TTA-A3-30-30

Tabletop Robot/Gate type 3-axis specification
XY-axes: 300mm, Z-axis: 100mm/150mm



Model Specification Items	Series	Type	Encoder type	X-axis stroke	X-axis option	Y-axis stroke	Y-axis option	Z-axis stroke	Z-axis option	Standard I/O Slot	Expansion I/O Slot 1	Expansion I/O Slot 2	I/O Cable length	Power Supply Cable Specification	Option
	TTA - A3	I	30	30	30	30	30	10 : 100mm 15 : 150mm	10 : 100mm 15 : 150mm	NP: NPN specification PN: PNP specification	1	1	0: None 2.2m 3.5m 5.5m	1: Power supply cable for 100VAC (2m) 2: Power supply cable for 200VAC (2m)	Refer to P.5

HS: Home confirmation sensor
 NM: Non-motor side specification
 * If the expansion I/O slot table below * If the expansion I/O slot is not used, enter "E".

* Refer to P.5 for the details of model specification items.

Model/Specifications

Model number	Axis configuration	Encoder type	Motor type	Lead (mm)	Stroke (mm)	Speed (mm/sec)	Payload (kg) (Note 1)
TTA-A3-I-30 ① - ③ ② - ③ B ④ - ⑤ - ⑥ - ⑦ - ⑧ - ⑨ - ⑩	X-axis Y-axis Z-axis	Incremental	Pulse motor	16 16 12	300 300 100/150	1~800 1~800 1~400	20 - 5

* In the above model number, ① and ② indicate the XY-axis options, ③ indicates the Z-axis stroke, ④ indicates the Z-axis option(s), ⑤ indicates the standard slot, ⑥ and ⑦ indicate the expansion slots, ⑧ indicates the I/O cable length, ⑨ indicates the power supply cable specification, and ⑩ indicates the selected option(s).

Expansion I/O Slot

Name	Model	Reference page
Not used	E	-
Expansion PIO board (NPN specification)*	NP	-
Expansion PIO board (PNP specification)*	PN	-
DeviceNet connection board	DV	-
CC-Link connection board	CC	-
PROFIBUS-DP connection board	PR	-
EtherNet/IP connection board*	EP	-

* Coming soon

Common specifications

Drive system	X/Y/Z-axis ball screw (X/Y-axis: ϕ 12mm, Z-axis: ϕ 10mm, rolled C10) X-axis and Y-axis speeds increased at 1.5:1 using a timing belt
Positioning repeatability	\pm 0.02mm (Note 2)
Lost motion	0.1mm or less
Guide	Ball-circulation type linear guide
Dynamic allowable moment (Note 3)	X-axis: Ma: 15.9 N·m Mb: 15.9 N·m Mc: 32.0 N·m Z-axis: Ma: 9.7 N·m Mb: 9.7 N·m Mc: 20.5 N·m
Ambient temperature/humidity	0 to 40°C, 85% RH max.(non-condensing)
Actuator weight	34kg

Dimensions

You can download CAD drawings from our website.



* During home return, the slider moves to the ME, so be careful to prevent contact with surrounding parts.

SE: Stroke end
ME: Mechanical end

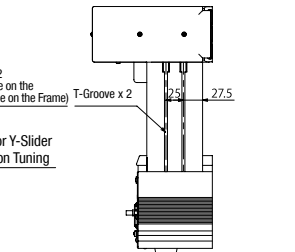
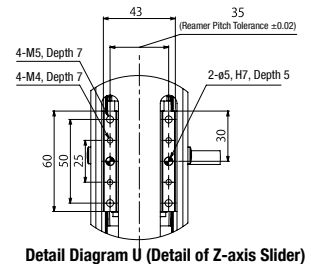
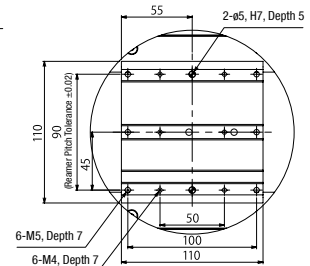
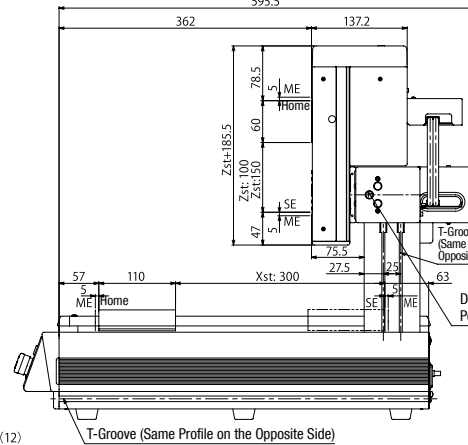
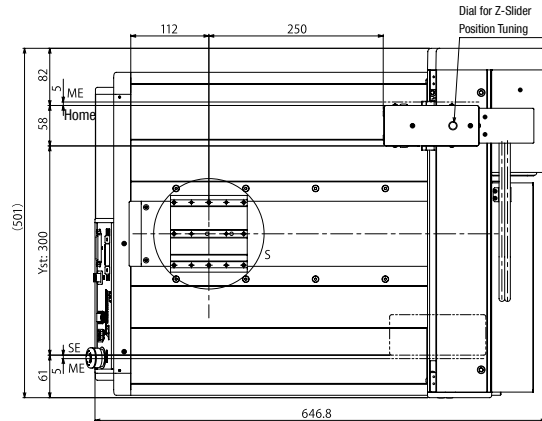
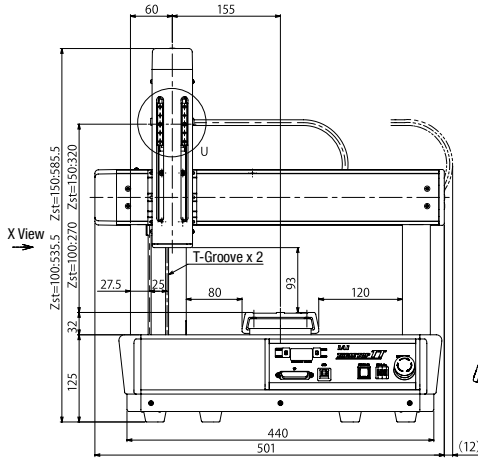
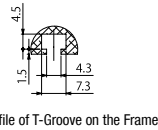

Applicable Controller Specifications

Applicable controller	Maximum number of controlled axes	Compatible encoder type	Program operation	Power-supply voltage	Page
Built-in	3 axes	Incremental	Program	AC100V AC200V	→ P16

 Caution	(Note 1) The maximum speed cannot be achieved based on the maximum payload setting. The payload decreases when the speed is increased. Also note that the maximum acceleration/deceleration varies depending on the payload. (Refer to P.6.)
	(Note 2) It is limited to when the actuator temperature is constant. It does not guarantee the absolute accuracy.
	(Note 3) The dynamic allowable moment is a value of each axis assuming a traveling life of 5,000km. (Refer to P.7 for the dynamic allowable moment.)

TTA-A3-40-40

Tabletop Robot/Gate type 3-axis specification
XY-axes: 400mm, Z-axis: 100mm/150mm



Model	TTA - A3 - I - 40	□ - 40	□ - □	□ - □	□ - □	□ - □	□ - □	□ - □	□ - □	□ - □	□ - □	□ - □	□ - □	□ - □	□ - □	□ - □	□ - □
Specification Items	Series	Type	Encoder type	X-axis stroke	X-axis stroke option	Y-axis stroke	Y-axis stroke option	Z-axis stroke	Z-axis stroke option	Standard I/O Slot	Expansion I/O Slot 1	Expansion I/O Slot 2	I/O Cable length	Power Supply Cable Specification	Option		
	A3: 3-axis (Gate)	I: Incremental specification	40: 400mm	40: 400mm	HS: Home confirmation sensor NM: Non-motor side specification	10: 100mm 15: 150mm	NP: NPN specification PN: PNP specification	Refer to the expansion I/O slot table below. * If the expansion I/O slot is not used, enter "E".	0: None 2.2m 3.3m 5.5m	1: Power supply cable for 100 VAC (2m) 2: Power supply cable for 200 VAC (2m)	Refer to P.5						

* Refer to P. 5 for the details of model specification items.

Model/Specifications

Model number	Axis configuration	Encoder type	Motor type	Lead (mm)	Stroke (mm)	Speed (mm/sec)	Payload (kg) (Note 1)
TTA-A3-I-40 ①-40 ②-③ B ④-⑤-⑥-⑦-⑧-⑨-⑩	X-axis	Incremental	Pulse motor	16	400	1-800	20
	Y-axis			16	400	1-800	-
	Z-axis			12	100/150	1-400	5

* In the above model number, ① and ② indicate the XY-axis options, ③ indicates the Z-axis stroke, ④ indicates the Z-axis options, ⑤ indicates the standard slot, ⑥ and ⑦ indicate the expansion slots, ⑧ indicates the I/O cable length, ⑨ indicates the power supply cable specification, and ⑩ indicates the selected option(s).

Expansion I/O Slot

Name	Model	Reference page
Not used	E	-
Expansion PIO board (NPN specification)*	NP	-
Expansion PIO board (PNP specification)*	PN	-
DeviceNet connection board	DV	-
CC-Link connection board	CC	-
PROFIBUS-DP connection board	PR	-
EtherNet/IP connection board*	EP	-

* Coming soon

Common specifications

Drive system	XY/Z-axis ball screw (X/Y-axis: ϕ 12mm, Z-axis: ϕ 10mm, rolled C10) X-axis and Y-axis speeds increased at 1.5:1 using a timing belt
Positioning repeatability	\pm 0.02mm (Note 2)
Lost motion	0.1mm or less
Guide	Ball-circulation type linear guide
Dynamic allowable moment (Note 3)	X-axis: Ma: 15.9 N·m Mb: 15.9 N·m Mc: 32.0 N·m Z-axis: Ma: 9.7 N·m Mb: 9.7 N·m Mc: 20.5 N·m
Ambient temperature/humidity	0 to 40°C, 85% RH max.(non-condensing)
Actuator weight	40kg

Dimensions

* During home return, the slider moves to the ME, so be careful to prevent contact with surrounding parts.

SE: Stroke end
ME: Mechanical end

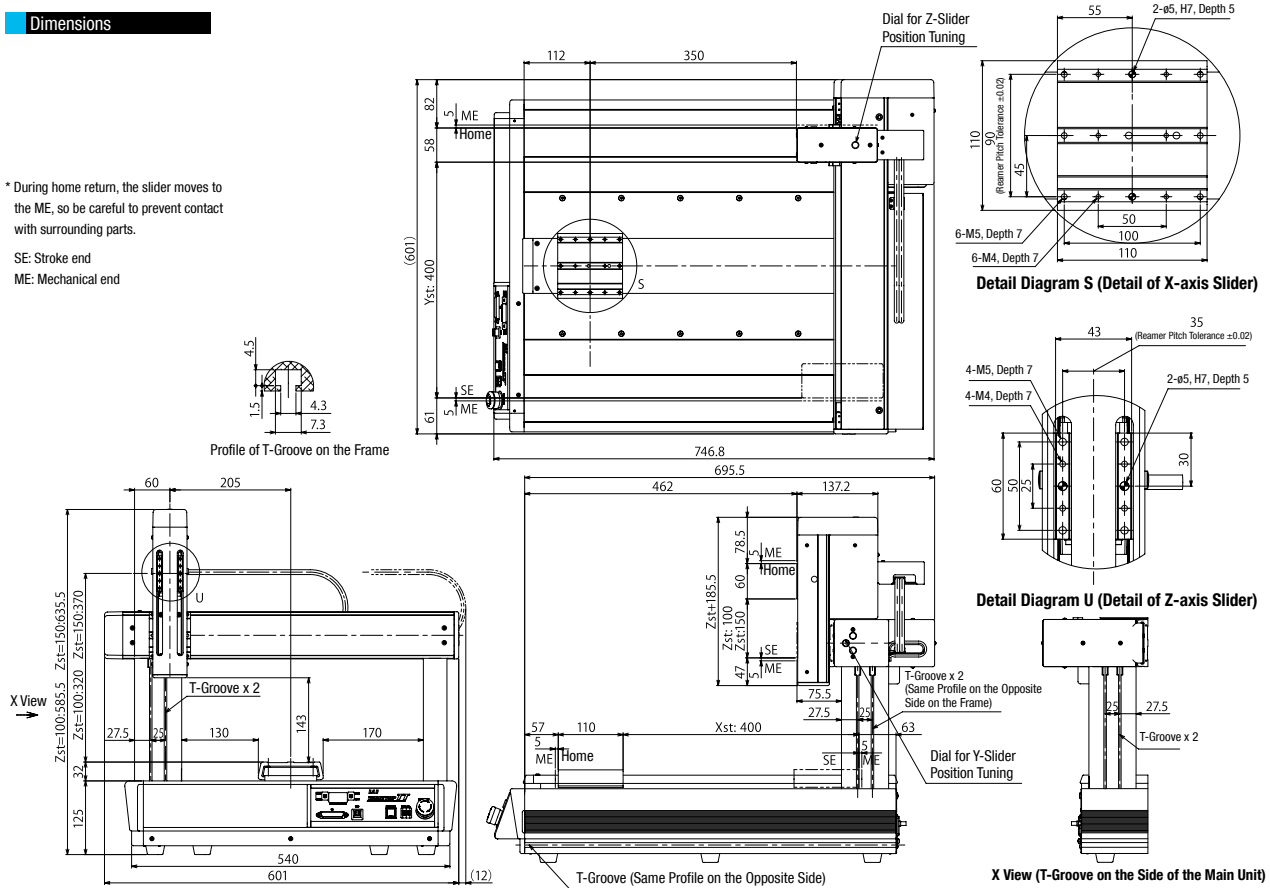

Applicable Controller Specifications

Applicable controller	Maximum number of controlled axes	Compatible encoder type	Program operation	Power-supply voltage	Page
Built-in	3 axes	Incremental	Program	AC100V AC200V	→ P16



Caution

(Note 1) The maximum speed cannot be achieved based on the maximum payload setting. The payload decreases when the speed is increased. Also note that the maximum acceleration/deceleration varies depending on the payload. (Refer to P. 6.)

(Note 2) It is limited to when the actuator temperature is constant. It does not guarantee the absolute accuracy.

(Note 3) The dynamic allowable moment is a value of each axis assuming a traveling life of 5,000km. (Refer to P. 7 for the dynamic allowable moment.)

TTA-A3-50-50

Tabletop Robot/Gate type 3-axis specification
XY-axes: 500mm, Z-axis: 100mm/150mm



Model Specification Items	TTA - A3 - I - 50	50																
	Series	Type	Encoder type	X-axis stroke	X-axis option	Y-axis stroke	Y-axis option	Z-axis stroke	Z-axis option	Standard I/O Slot	Expansion I/O Slot 1	Expansion I/O Slot 2	I/O Cable length	Power Supply Cable Specification	Option			
	A3: 3-axis (Gate)	I: Incremental specification	50: 500mm	50: 500mm		10: 100mm 15: 150mm		NP: NPN specification PN: PNP specification	HS: Home confirmation sensor NM: Non-motor side specification				D: None 2.2m 3.3m 5.5m	P1: Mating plug (No cable) 2: Power supply cable for 100 VAC (2 m) 2: Power supply cable for 200 VAC (2 m)	Refer to P.5			

* Refer to P.5 for the details of model specification items.

Model/Specifications

Model number	Axis configuration	Encoder type	Motor type	Lead (mm)	Stroke (mm)	Speed (mm/sec)	Payload (kg) (Note 1)
TTA-A3-I-50 ①-⑤②-③B④-⑤-⑥-⑦-⑧-⑨-⑩	X-axis	Incremental	Pulse motor	16	500	1~800	20
	Y-axis			16	500	1~800	-
	Z-axis			12	100/150	1~400	5

* In the above model number, ① and ② indicate the XY-axis options, ③ indicates the Z-axis stroke, ④ indicates the Z-axis option(s), ⑤ indicates the standard slot, ⑥ and ⑦ indicate the expansion slots, ⑧ indicates the I/O cable length, ⑨ indicates the power supply cable specification, and ⑩ indicates the selected option(s).

Expansion I/O Slot

Name	Model	Reference page
Not used	E	-
Expansion PIO board (NPN specification)*	NP	-
Expansion PIO board (PNP specification)*	PN	-
DeviceNet connection board	DV	-
CC-Link connection board	CC	-
PROFIBUS-DP connection board	PR	-
EtherNet/IP connection board*	EP	-

* Coming soon

Common specifications

Drive system	X/Y/Z-axis ball screw (X/Y-axis: ø12mm, Z-axis: ø10mm, rolled C10) X-axis and Y-axis speeds increased at 1.5:1 using a timing belt
Positioning repeatability	±0.02mm (Note 2)
Lost motion	0.1mm or less
Guide	Ball-circulation type linear guide
Dynamic allowable moment (Note 3)	X-axis: Ma: 15.9 N·m Mb: 15.9 N·m Mc: 32.0 N·m Z-axis: Ma: 9.7 N·m Mb: 9.7 N·m Mc: 20.5 N·m
Ambient temperature/humidity	0 to 40°C, 85% RH max.(non-condensing)
Actuator weight	47kg

Dimensions

* During home return, the slider moves to the ME, so be careful to prevent contact with surrounding parts.

SE: Stroke end
ME: Mechanical end

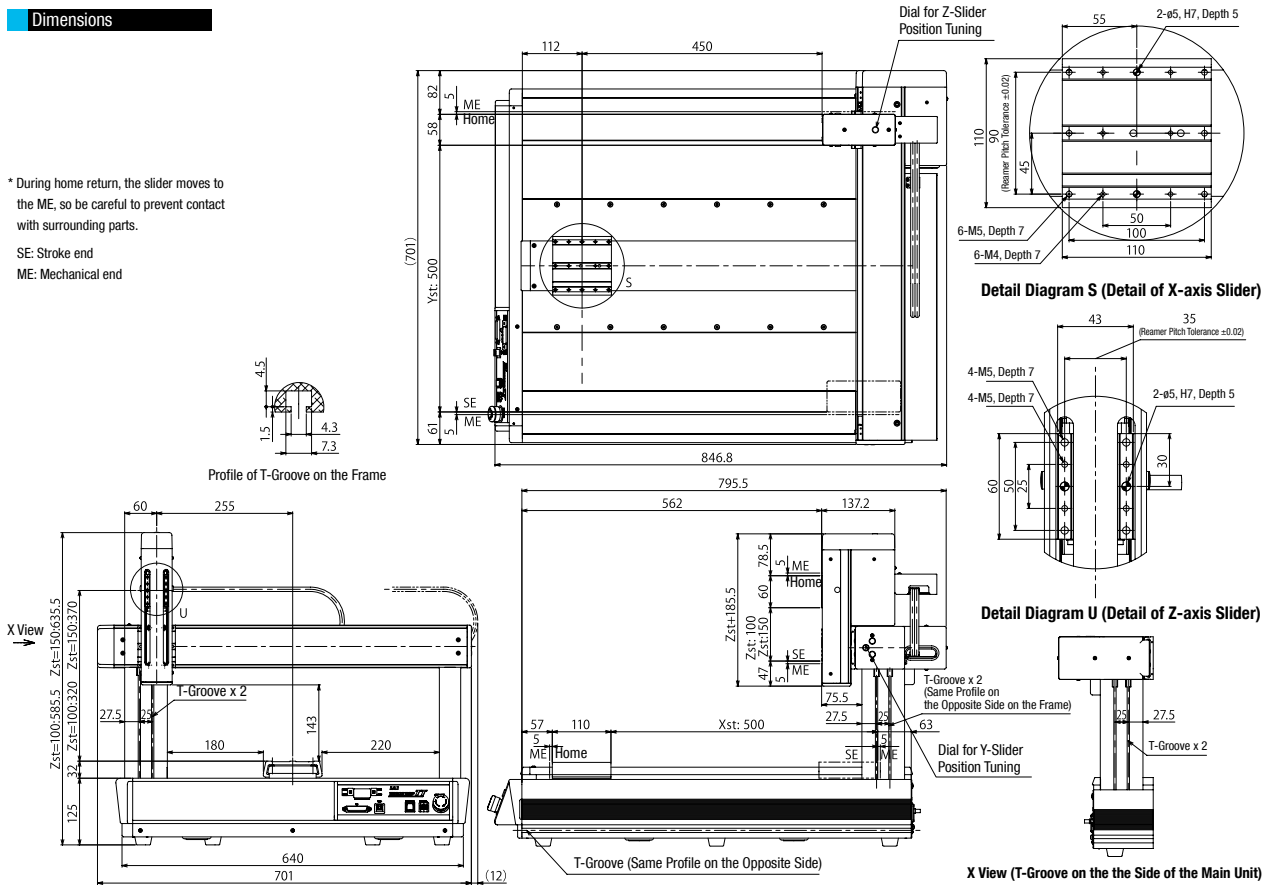

Applicable Controller Specifications

Applicable controller	Maximum number of controlled axes	Compatible encoder type	Program operation	Power-supply voltage	Page
Built-in	3 axes	Incremental	Program	AC100V AC200V	→ P16



(Note 1) The maximum speed cannot be achieved based on the maximum payload setting. The payload decreases when the speed is increased. Also note that the maximum acceleration/deceleration varies depending on the payload. (Refer to P.6.)

(Note 2) It is limited to when the actuator temperature is constant. It does not guarantee the absolute accuracy.

(Note 3) The dynamic allowable moment is a value of each axis assuming a traveling life of 5,000km. (Refer to P.7 for the dynamic allowable moment.)

15

TTA-A3-50-50

Sold & Serviced By:

ELECTROMATE

Toll Free Phone (877) SERV098

Toll Free Fax (877) SERV099

www.electromate.com

sales@electromate.com

Controller Specification

Item			
Motor type		Pulse motor (Servo control)	
Applicable encoder		Incremental encoder	
Data-storage device		Flash ROM/FRAM	
Number of program steps		9,999	
Number of positions		30,000	
Number of programs		255	
Number of multi-tasking programs		16	
Operation mode	Serial communication	○	
	Program	○	
	Positioner	×	
	Pulse train	×	
SIO interface	Communication method	RS232	
	Baud rate	9.6, 19.2, 38.4, 57.6, 76.8, 115.2kpps	
	Live wire insertion/removal	TP port	×
		USB	○
Standard I/O Interface	Input specification	Number of input	16 points
		Input voltage	DC24V±10%
		Input current	7 mA per circuit
		ON voltage	Min. DC16V
		OFF voltage	Max. DC5V
		Leak current	Allowable leak current: 1 mA max.
	Output specification	Number of output	16 points
		Load voltage	DC24V±10%
		Maximum current	100 mA per point, 400 mA per 8 points Note 1
		Saturated voltage	Max.3V
		Leak current	Max 0.1 mA
		Isolation method	Photocoupler isolation
Conforming expansion I/O interfaces	Expansion PIO NPN specification (16IN/16OUT)		
	Expansion PIO PNP specification (16IN/16OUT)		
	CC-Link (remote device)		
	DeviceNet		
	PROFIBUS-DP		
	EtherNet/IP		
Brake output voltage		DC24V±10%	
Connectable brake power		Max.5W	
Calendar/clock function	Retention time	Approx. 10 days	
	Charge time	Approx. 100 hours	
Protective functions		Monitoring of overcurrent, fan speed drop, etc.	

Note 1: The total load current for every 8 points from Standard I/O No. 316 is 400 mA. (The maximum value per point is 100 mA.)

PIO Signal Table

Standard PIO Connector Pin Layout

Pin No.	Classification	Assignment	Pin No.	Classification	Assignment
1A	24V *	P24	1B	Output	OUT0
2A	24V *	P24	2B		OUT1
3A	-	-	3B		OUT2
4A	-	-	4B		OUT3
5A	Input	IN0	5B		OUT4
6A		IN1	6B		OUT5
7A		IN2	7B		OUT6
8A		IN3	8B		OUT7
9A		IN4	9B		OUT8
10A		IN5	10B		OUT9
11A		IN6	11B		OUT10
12A		IN7	12B		OUT11
13A		IN8	13B		OUT12
14A		IN9	14B		OUT13
15A		IN10	15B		OUT14
16A		IN11	16B	OUT15	
17A		IN12	17B	-	-
18A		IN13	18B	-	-
19A	IN14	19B	0V *	N	
20A	IN15	20B	0V *	N	

* [24 V]/[0 V] indicates the 24-V power input when the service power output is OFF, or 24-V power output when the service power output is ON.

* [24 V]/[0 V] must not be connected to an external power supply when the service power output is ON.

Expansion PIO Connector Pin Layout

Pin No.	Classification	Assignment	Pin No.	Classification	Assignment
1A	24V *	P24	1B	Output	OUT0
2A	24V *	P24	2B		OUT1
3A	-	-	3B		OUT2
4A	-	-	4B		OUT3
5A	Input	IN0	5B		OUT4
6A		IN1	6B		OUT5
7A		IN2	7B		OUT6
8A		IN3	8B		OUT7
9A		IN4	9B		OUT8
10A		IN5	10B		OUT9
11A		IN6	11B		OUT10
12A		IN7	12B		OUT11
13A		IN8	13B		OUT12
14A		IN9	14B		OUT13
15A		IN10	15B		OUT14
16A		IN11	16B	OUT15	
17A		IN12	17B	-	-
18A		IN13	18B	-	-
19A	IN14	19B	0V *	N	
20A	IN15	20B	0V *	N	

* [24 V]/[0 V] (not connected to the service power) must be supplied with power even when the service power output is ON.

I/O cable (CB-PAC-PIO) * Enter the cable length (L) in Lengths up to 10 m are supported.
Example) 080 = 8 m

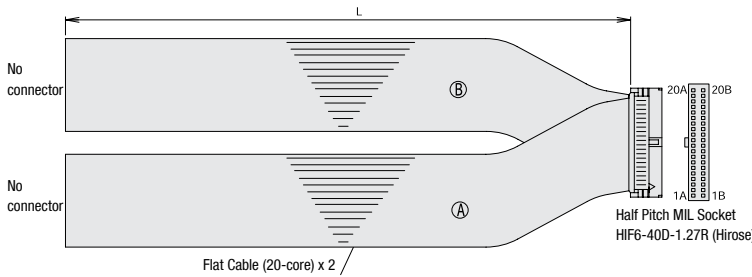

HIF6-40D-1.27R

No	Signal Name	Cable Color	Wiring	No	Signal Name	Cable Color	Wiring
1A	24V	Brown-1	Flat Cable (A) (Crimped)	1B	OUT0	Brown-3	Flat Cable (B) (Crimped) AWG28
2A	24V	Red-1		2B	OUT1	Red-3	
3A	-	Orange-1		3B	OUT2	Orange-3	
4A	-	Yellow-1		4B	OUT3	Yellow-3	
5A	IN0	Green-1		5B	OUT4	Green-3	
6A	IN1	Blue-1		6B	OUT5	Blue-3	
7A	IN2	Purple-1		7B	OUT6	Purple-3	
8A	IN3	Gray-1		8B	OUT7	Gray-3	
9A	IN4	White-1		9B	OUT8	White-3	
10A	IN5	Black-1		10B	OUT9	Black-3	
11A	IN6	Brown-2		11B	OUT10	Brown-4	
12A	IN7	Red-2		12B	OUT11	Red-4	
13A	IN8	Orange-2		13B	OUT12	Orange-4	
14A	IN9	Yellow-2		14B	OUT13	Yellow-4	
15A	IN10	Green-2		15B	OUT14	Green-4	
16A	IN11	Blue-2		16B	OUT15	Blue-4	
17A	IN12	Purple-2		17B	-	Purple-4	
18A	IN13	Gray-2		18B	-	Gray-4	
19A	IN14	White-2		19B	0V	White-4	
20A	IN15	Black-2		20B	0V	Black-4	

I/O Wiring Diagram (Standard PIO)

■ Input Part: External input specification (NPN specification)

Item	Specification
Input voltage	24 VDC + 10%
Input current	7 mA/circuit
ON/OFF voltages	ON voltage---16.0 VDC min., OFF voltage---5.0 VDC max.
Isolation method	Photocoupler isolation

* The circuit diagram below assumes that the power is input externally (the service power output is OFF).
 * In the circuit diagram below, the port numbers conform to the standard factory settings.
 * The allowable leak current is 1 mA when the input is OFF.

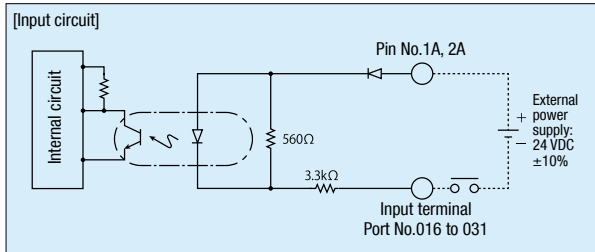

■ Output Part: External output specification (NPN specification)

Item	Specification
Load voltage	24 VDC
Maximum load current	100 mA/point, 400 mA/8 ports (Note)
Leak current	0.1 mA/point max.
Isolation method	Photocoupler isolation

TD62084
(or equivalent)

* The circuit diagram assumes that the power is input externally (the service power output is OFF).
 * In the circuit diagram below, the port numbers conform to the standard factory settings.
 Note: The total load current for every 8 points from Standard I/O No. 316 is 400 mA.
 (The maximum value per point is 100 mA.)

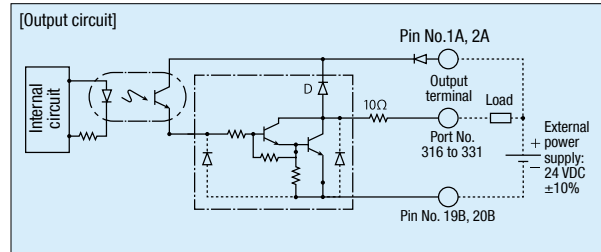

■ Input Part: External input specification (PNP specification)

Item	Specification
Input voltage	24 VDC + 10%
Input current	7 mA/circuit
ON/OFF voltages	ON voltage---8.0 VDC max., OFF voltage---19.0 VDC min.
Isolation method	Photocoupler isolation

* The circuit diagram below assumes that the power is input externally (the service power output is OFF).
 * In the circuit diagram below, the port numbers conform to the standard factory settings.
 * The allowable leak current is 1 mA when the input is OFF.

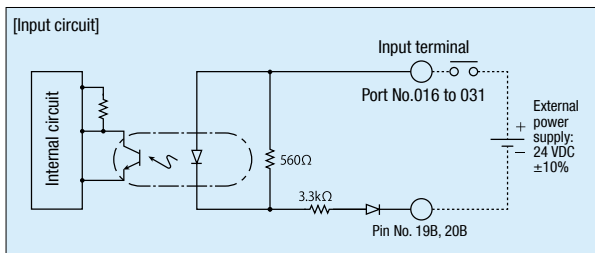

■ Output Part: External output specification (PNP specification)

Item	Specification
Load voltage	24 VDC
Maximum load current	100 mA/point, 400 mA/8 ports (Note)
Leak current	0.1 mA/point max.
Isolation method	Photocoupler isolation

TD62783
(or equivalent)

* The circuit diagram assumes that the power is input externally (the service power output is OFF).
 * In the circuit diagram below, the port numbers conform to the standard factory settings.
 Note: The total load current for every 8 points from Standard I/O No. 316 is 400 mA.
 (The maximum value per point is 100 mA.)

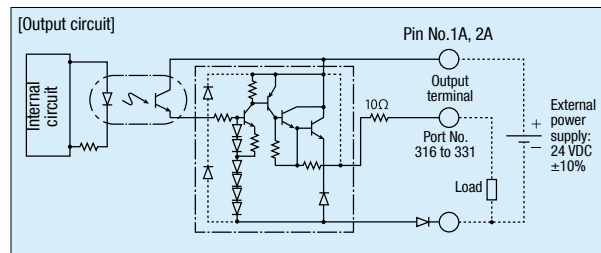

I/O Wiring Diagram (Expansion PIO)

Input Part: External input specification

Item	Specification
Number of input	16 points
Input voltage	24 VDC + 10%
Input current	4 mA/circuit
ON/OFF voltages	ON voltage---18.0 VDC min. (3.5 mA), OFF voltage---6.0 VDC max. (1 mA)
Isolation method	Photocoupler isolation

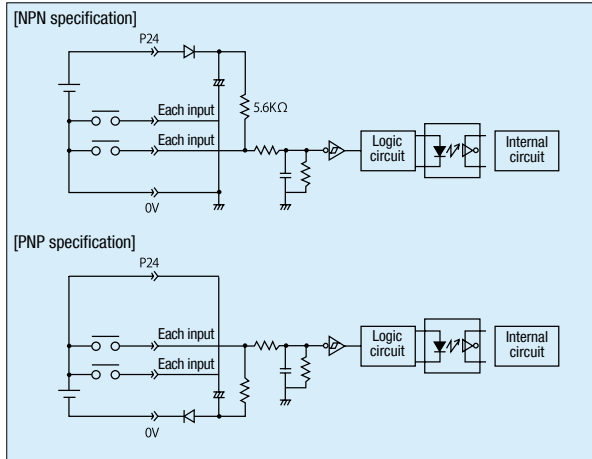

Output Part: External output specification

Item	Specification
Number of output	16 points
Rated load voltage	24 VDC
Maximum current	50 mA/circuit
Isolation method	Photocoupler isolation

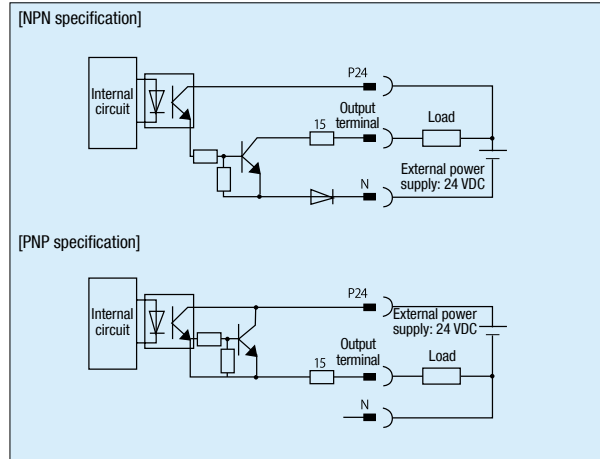

Front

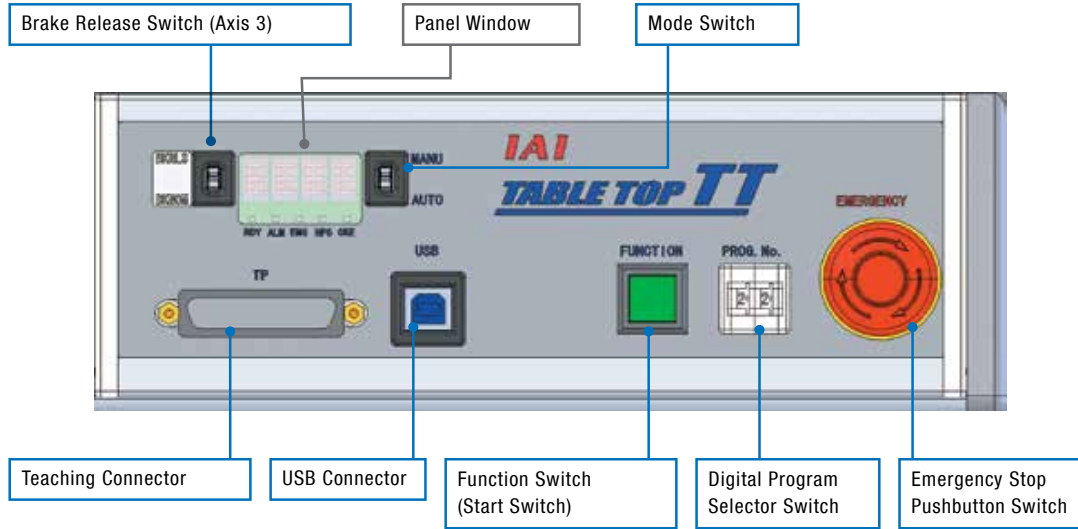

Rear

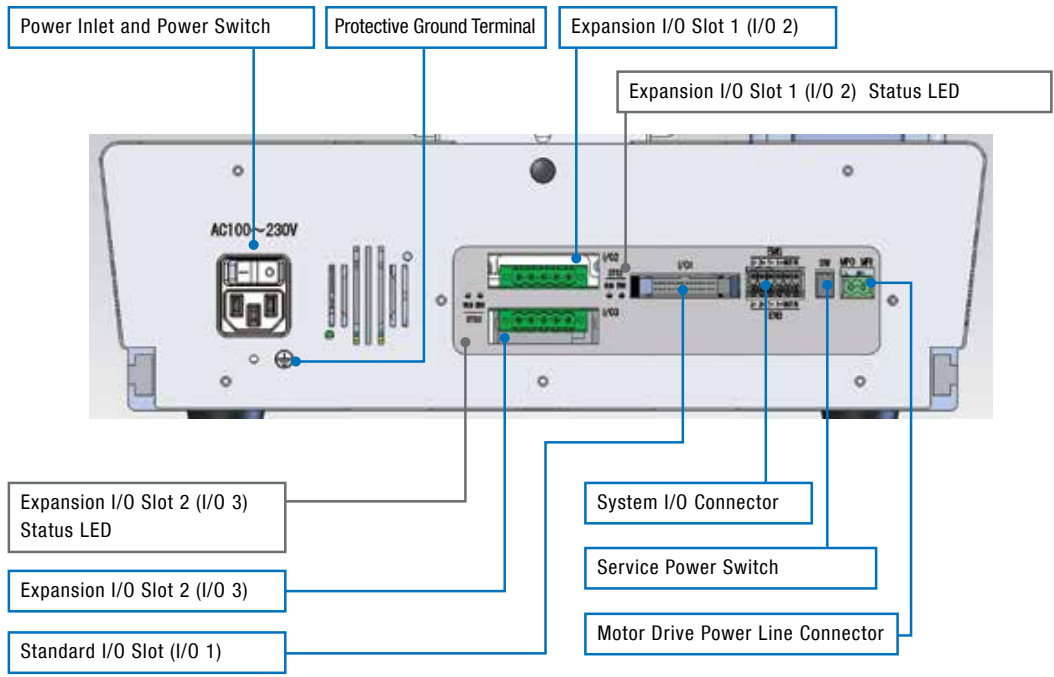

I/O Interface

Standard I/O slot	Standard PIO (Input 16 points/output 16 points)
Expansion I/O slot 1 [Option]	Expansion PIO (Input 16 points/output 16 points), or Field Network (*1)
Expansion I/O slot 2 [Option]	Expansion PIO (Input 16 points/output 16 points), or Field Network (*1)
System I/O slot	Emergency stop input 2 contacts, enable input 2 contacts
Motor power I/O connector	For cutting off external drive power

*1: For field network (CC-Link, DeviceNet, PROFIBUS-DP or EtherNet/IP) connection, the maximum number of input points is 240 and maximum number of output points is 240. EtherNet/IP + EtherNet/IP is not supported. Connect the vision system to EtherNet/IP.

Teaching Pendant

- Features** Supporting both programmable controllers and position controllers
 Easy-to-use design combining a touch panel and keys
 3.5" full-color touch panel
 SEL programs can be edited
 Programs/data can be saved to SD cards
 Calendar function



Specifications

Rated voltage	24V DC
Operating voltage range	21.6 to 26.4V DC
Power consumption	3.6W or less (150mA or less)
Ambient operating temperature	0 to 50°C
Ambient operating humidity	20 to 85% RH (non-condensing)
Ambient storage temperature	-20 to 60°C
Ambient storage humidity	10 to 85% RH (non-condensing)
Vibration durability	10 to 55Hz (1 minute periods), double amplitude 0.75mm, 10 minutes each in X/Y/Z directions
Impact durability	147m/s ² , 11msec, 4 times each in X/Y/Z directions
Environmental resistance	IP40 (in initial state)
Weight	507g (TB-01-N; teaching pendant only)

External Dimensions

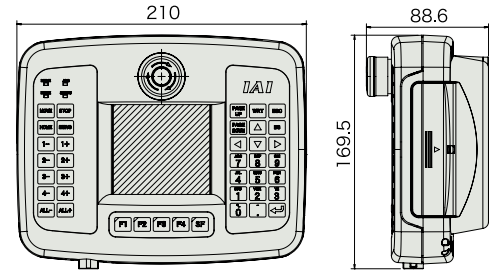

(Unit: mm)

PC Software (for Windows PCs only)

- Features** A startup support software program offering program/position input function, test operation function, monitoring function, and more. The functions needed for debugging have been enhanced to help reduce the startup time.

Note: The TTA series only supports Version 10.0.0.0 or later.

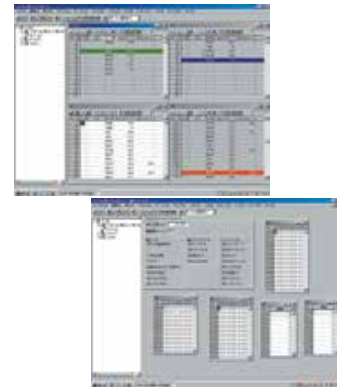

- Model number** **IA-101-X-MW** (RS232C Cable Included)

- Configuration**

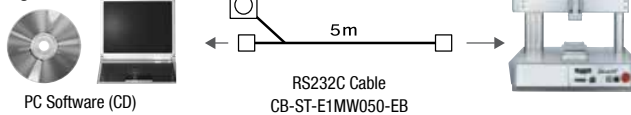

- Model number** **IA-101-TTA-USB** (USB Cable Included)

- Configuration**

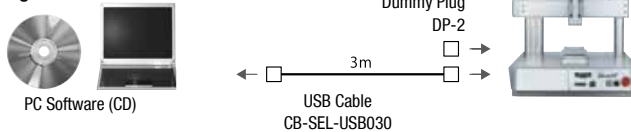

Note. IA-101-TT-USB can be used with the TTA series by updating the software version. To make the TTA series compatible with a safety category, the dummy plug DP-2 is required.

- Model number** **IA-101-X-USBMW** (USB Conversion adapter + Cable Included)

- Configuration**

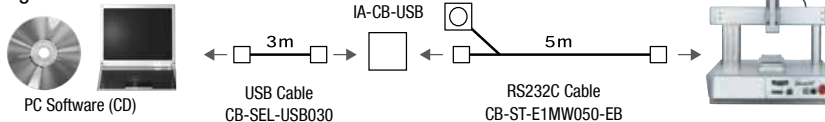

- **Features** Connect this plug to the teaching connector to cut off the enable circuit when the TTA series is linked to a PC using a USB cable.

- **Model number** **DP-2** The plug comes with the PC software (Model IA-101-TTA-USB).

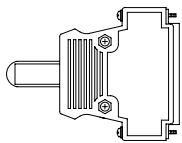

- The plug supports emergency stop/enable circuit redundancy (category 3 or higher).

I/O Conversion Cable

- **Features** This conversion cable is used to connect the I/O flat cable (CB-DS-PIO □□□) for conventional TT series to the standard I/O slot of the TTA series.

- **Model number** **CB-TTA-PIOJ005**

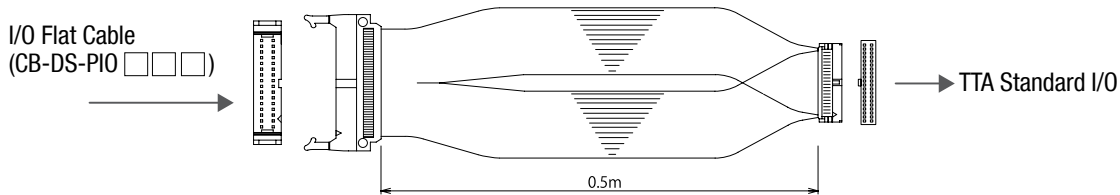

Actuator Mounting Brackets

(Comes with bolts/nuts for installing the bracket to the actuator)

- **Model number** **TTA-FT-4** for Stroke 20-20/30-30 (Foot bracket, Set of 4 pcs)
TTA-FT-6 for Stroke 40-40/50-50 (Foot bracket, Set of 6 pcs)

- **Dimensions**

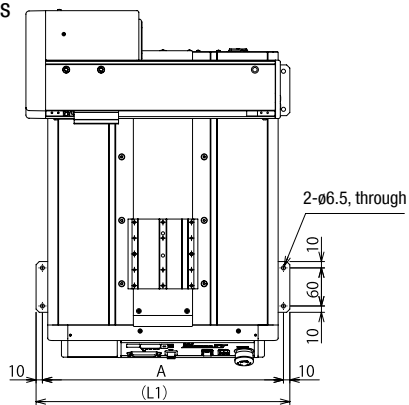

Model	L1	L2	A
2020	400	430	380
3030	500	530	480
4040	600	630	580
5050	700	730	680

