

Dimensions

For Special Orders P. A-9

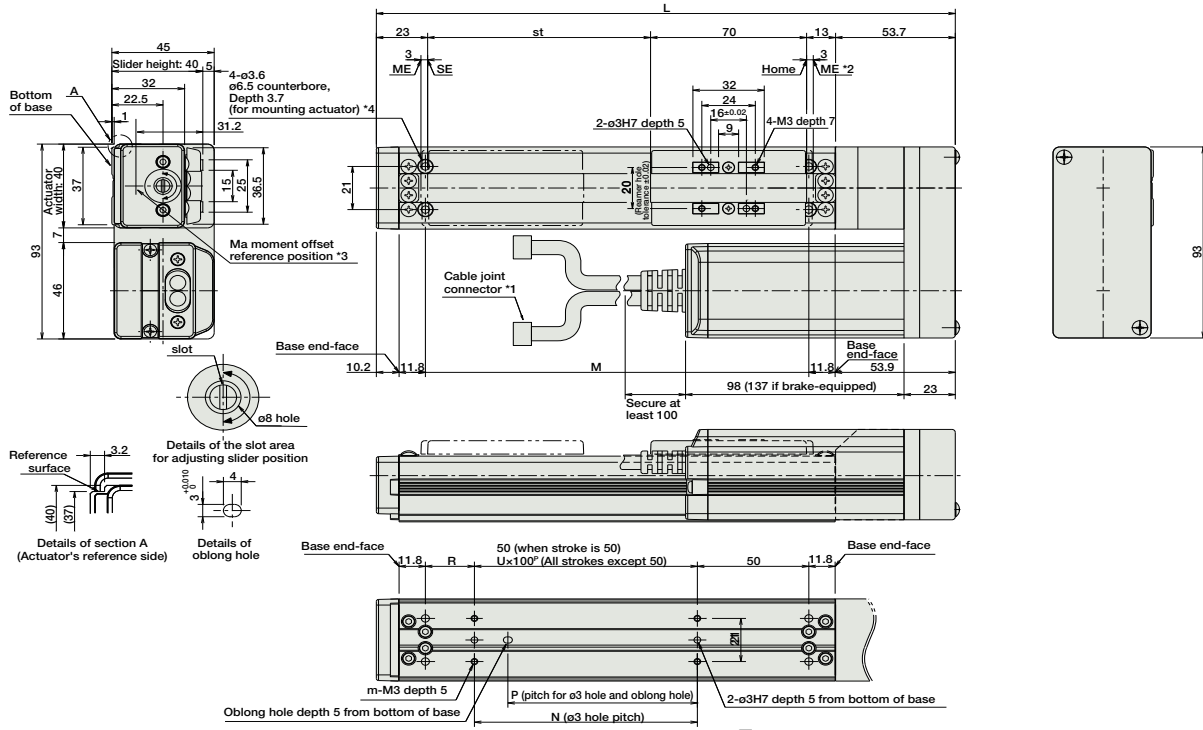

- *1 The motor-encoder cable is connected here. See page A-39 for details on cables.
- *2 When homing, the slider moves to the ME; therefore, please watch for any interference with the surrounding objects.
ME: Mechanical end SE: Stroke end
- *3 Reference position for calculating the moment Ma.
- *4 If the actuator is secured using only the mounting holes provided on the top surface of the base, the base may twist to cause abnormal sliding of the slider, or may produce abnormal noise. Therefore, when using the mounting holes on the top surface of the base, keep the stroke at 200mm or less.

■ Dimensions/Weight by Stroke * Brake-equipped models are heavier by 0.3kg.

Stroke	50	100	150	200	250	300	350	400
L	209.7	259.7	309.7	359.7	409.7	459.7	509.7	559.7
M	122	172	222	272	322	372	422	472
N	50	100	100	200	200	300	300	400
P	35	85	85	185	185	285	285	385
R	22	22	72	22	72	22	72	22
U	-	1	1	2	2	3	3	4
m	4	4	4	6	6	8	8	10
Weight (kg)	0.8	0.9	1.0	1.1	1.2	1.3	1.4	1.5

③ Compatible Controllers

The RCS2 series actuators can operate with the controllers below. Select the controller according to your usage.

Name	External View	Model	Description	Max. Positioning Points	Input Voltage	Power Supply Capacity	Standard Price	See Page
Positioner Mode		SCON-C-20①-NP-2-②	Positioning is possible for up to 512 points	512 points	Single-Phase AC 100V Single-Phase AC 200V 3-Phase AC 200V (XSEL-P/Q only)	360VA max. * When operating a 150W single-axis model	-	→ P547
Solenoid Valve Mode			Operable with same controls as solenoid valve.	7 points				
Serial Communication Type			Dedicated to serial communication	64 points				
Pulse Train Input Control Type			Dedicated to Pulse Train Input	(-)				
Program Control 1-2 Axis Type		SSEL-C-1-20①-NP-2-②	Programmed operation is possible Can operate up to 2 axes	20000 points			-	→ P577
Program Control 1-6 Axis Type		XSEL-③-1-20①-N1-EEE-2-④	Programmed operation is possible Can operate up to 6 axes	20000 points			-	→ P587

- * For SSEL and XSEL, only applicable to the single-axis model.
- * ① is a placeholder for the encoder type (I: incremental, A: absolute).
- * ② is a placeholder for the power supply voltage (1: 100V, 2: single-phase 200V, 3: 3-phase 200V).
- * ③ is a placeholder for the XSEL type name (J, K, P, or Q).
- * ④ is a placeholder for the power supply voltage (1: 100V, 2: single-phase 200V, 3: 3-phase 200V).

- Slider Type
- Mini
- Standard
- Controllers Integrated
- Rod Type
- Mini
- Standard
- Controllers Integrated
- Table/Arm /Flat Type
- Mini
- Standard
- Gripper/ Rotary Type
- Linear Servo Type
- Cleanroom Type
- Splash-Proof
- Controllers
- PMEC /AMEC
- PSEP /ASEP
- ROBO NET
- ERC2
- PCON
- ACON
- SCON
- PSEL
- ASEL
- SSEL
- XSEL
- Pulse Motor
- Servo Motor (24V)
- Servo Motor (200V)
- Linear Servo Motor