

RCS2-RGS4D

ROBO Cylinder Rod Type with Single Guide ø37mm Diameter 200V Servo Motor
Built-In Model

■ Configuration: **RCS2** — **RGS4D** — — — — — — — — —

Series — Type — Encoder — Motor — Lead — Stroke — Compatible Controllers — Cable Length — Option

I : Incremental
A : Absolute

60 : 60W Servo Motor
30 : 30W Servo Motor

12 : 12mm
6 : 6mm
3 : 3mm

50 : 50mm
300 : 300mm (50mm pitch increments)

T1 : XSEL-J/K
T2 : SCON
SSEL
XSEL-P/Q

N : None
P : 1m
S : 3m
M : 5m
X : Custom
R : Robot cable

* See page Pre-35 for an explanation of the naming convention.

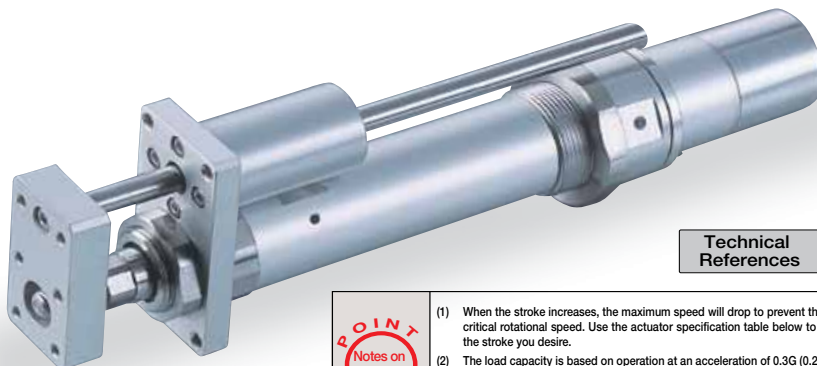

Technical References P. A-5

- 4 POINT Notes on Selection**
- (1) When the stroke increases, the maximum speed will drop to prevent the ball screw from reaching the critical rotational speed. Use the actuator specification table below to check the maximum speed at the stroke you desire.
 - (2) The load capacity is based on operation at an acceleration of 0.3G (0.2G for the 3mm-lead model). This is the upper limit of the acceleration.
 - (3) The values for the horizontal load capacity assume the use of an external guide, so that there is no external force from any direction other than the forward/backward direction of the rod. See the technical resources (page A-82) for the allowable weight using the supplied guide alone.

Actuator Specifications					
■ Lead and Load Capacity					
Model	Motor Output (W)	Lead (mm)	Max. Load Capacity		Rated Thrust (N)
			Horizontal (kg)	Vertical (kg)	
RCS2-RGS4D-①-20-12-②-③-④-⑤	20	12	3.0	0.5	18.9
RCS2-RGS4D-①-20-6-②-③-④-⑤		6	6.0	1.5	37.7
RCS2-RGS4D-①-20-3-②-③-④-⑤	30	3	12.0	3.5	75.4
RCS2-RGS4D-①-30-12-②-③-④-⑤		12	4.0	1.0	28.3
RCS2-RGS4D-①-30-6-②-③-④-⑤		6	9.0	2.5	56.6
RCS2-RGS4D-①-30-3-②-③-④-⑤		3	18.0	6.0	113.1

Legend: ① Encoder ② Stroke ③ Compatible controller ④ Cable length ⑤ Options

■ Stroke and Maximum Speed		
Stroke	50 ~ 300 (50mm increments)	
	Lead	50 ~ 300 (50mm increments)
12		600
6		300
3		150

(Unit: mm/s)

Encoder & Stroke List				
② Stroke (mm)	Standard Price			
	① Encoder			
	Incremental		Absolute	
	Motor Output (W)		Motor Output (W)	
	20W	30W	20W	30W
50	-	-	-	-
100	-	-	-	-
150	-	-	-	-
200	-	-	-	-
250	-	-	-	-
300	-	-	-	-

④ Cable List		
Type	Cable Symbol	Standard Price
Standard	P (1m)	-
	S (3m)	-
	M (5m)	-
Special Lengths	X06 (6m) ~ X10 (10m)	-
	X11 (11m) ~ X15 (15m)	-
	X16 (16m) ~ X20 (20m)	-
	R01 (1m) ~ R03 (3m)	-
Robot Cable	R04 (4m) ~ R05 (5m)	-
	R06 (6m) ~ R10 (10m)	-
	R11 (11m) ~ R15 (15m)	-
	R16 (16m) ~ R20 (20m)	-

* See page A-39 for cables for maintenance.

⑤ Option List			
Name	Option Code	See Page	Standard Price
Foot bracket	FT	→ A-29	-
Home sensor	HS	→ A-32	-
Reversed-home	NM	→ A-33	-
Trunnion bracket (back)	TRR	→ A-38	-

* The home sensor (HS) cannot be used on the reversed-home models.

Actuator Specifications	
Item	Description
Drive System	Ball screw ø10mm C10 grade
Positioning Repeatability	±0.02mm
Lost Motion	0.1mm or less
Guide	Single guide (guide rod diameter ø10mm, Ball bush type)
Rod Diameter	ø20mm
Non-rotating accuracy of rod	±0.05 deg
Ambient Operating Temp./Humidity	0 ~ 40°C, 85% RH or less (non-condensing)

253

RCS2-RGS4D

Dimensions

For Special Orders P. A-9

- *1. The motor-encoder cable is connected here. See page A-39 for details on cables.
- *2. When homing, the rod moves to the ME; therefore, please watch for any interference with the surrounding objects.
ME: Mechanical end SE: Stroke end

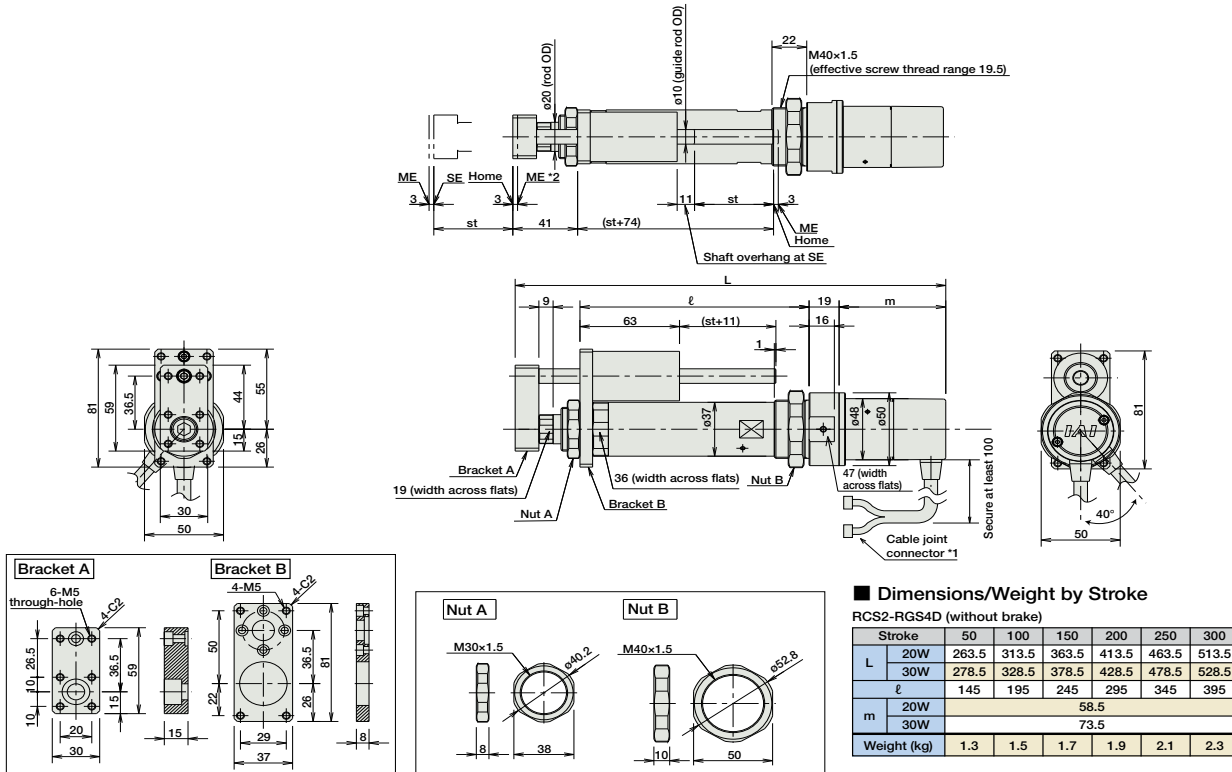

■ Dimensions/Weight by Stroke

RCS2-RGS4D (without brake)

Stroke	50	100	150	200	250	300	
L	20W	263.5	313.5	363.5	413.5	463.5	513.5
	30W	278.5	328.5	378.5	428.5	478.5	528.5
ℓ	145	195	245	295	345	395	
m	58.5						
	73.5						
Weight (kg)	1.3	1.5	1.7	1.9	2.1	2.3	

RCS2-RGS4D does not come in a brake-equipped configuration.

③ Compatible Controllers

The RCS2 series actuators can operate with the controllers below. Select the controller according to your usage.

Name	External View	Model	Description	Max. Positioning Points	Input Voltage	Power Supply Capacity	Standard Price	See Page
Positioner Mode		SCON-C-20①-NP-2-② SCON-C-30D①-NP-2-②	Positioning is possible for up to 512 points	512 points	Single-Phase AC 100V Single-Phase AC 200V 3-Phase AC 200V (XSEL-P/Q only)	Maximum 360VA * Single-axis model operated at 150W	-	→ P547
Solenoid Valve Mode			Operable with the same controls as the solenoid valve.	7 points				
Serial Communication Type			Dedicated to serial communication	64 points				
Pulse Train Input Control Type			Dedicated to Pulse Train Input	(-)				
Program Control 1-2 Axes Type		SSEL-C-1-20①-NP-2-② SSEL-C-1-30D①-NP-2-②	Programmed operation is possible Operation is possible on up to 2 axes	20000 points			-	→ P577
Program Control 1-6 Axes Type		XSEL-③-1-20①-N1-EEE-2-④ XSEL-③-1-30D①-N1-EEE-2-④	Programmed operation is possible Operation is possible on up to 6 axes	20000 points			-	→ P587

* For SSEL and XSEL, only applicable to the single-axis model.
 * ① is a placeholder for the encoder type (I: incremental / A: absolute).
 * ② is a placeholder for the power supply voltage (1: 100V, 2: single-phase 200V).
 * ③ is a placeholder for the XSEL type name ("J", "K", "P", or "Q").
 * ④ is a placeholder for the power supply voltage (1: 100V, 2: single-phase 200V, or 3: three-phase 200V).

- Slider Type
- Mini
- Standard
- Controllers Integrated
- ROD Type
- Mini
- Standard
- Controllers Integrated
- Table/Arm /Flat Type
- Mini
- Standard
- Gripper/ Rotary Type
- Linear Servo Type
- Cleanroom Type
- Splash Proof
- Controllers
- PMEC /AMEC
- PSEP /ASEP
- ROBO NET
- ERC2
- PCON
- ACON
- SCON
- PSEL
- ASEL
- SSEL
- XSEL
- Pulse Motor
- Servo Motor (24V)
- Servo Motor (200V)
- Linear Servo Motor