



Quality and Innovation

Medium High-force Gripper

Large High-force Gripper

RCP2-GRHM
RCP2-GRHB



Sold & Serviced By:
 **ELECTROMATE**

Toll Free Phone (877) SERV098
Toll Free Fax (877) SERV099
www.electromate.com
sales@electromate.com

A high-force gripper series offering much greater gripping force and moment rigidity is now available!

The full lineup includes models of various sizes from small to large.



Features

1 Greater gripping force
The maximum gripping force is 200 N (~45lb), meaning that even heavy work parts can be gripped without fail. It is also possible to adjust the gripping force for each work part, so difficult-to-handle work parts such as those that deform easily are also supported.

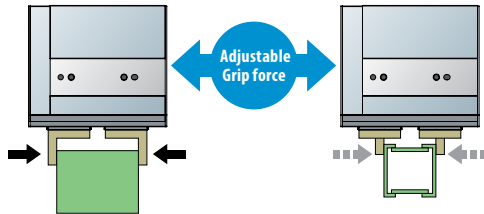

2 Higher rigidity
Moment rigidity is achieved using internal ball guides. Large work parts can be supported.

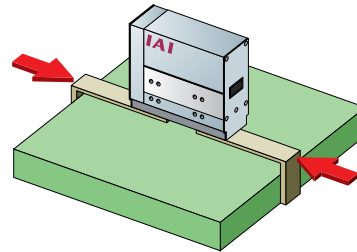

3 Longer stroke
Long strokes of up to 40 mm (20 mm per side) are supported, so work parts of different sizes can also be handled.

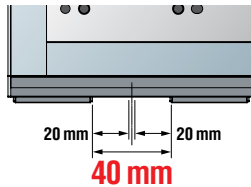

4 Cable exit direction (optional)
The cables can exit to one of four directions including top, bottom, left and right.

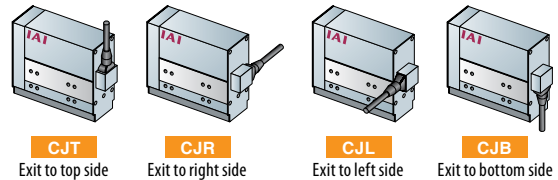

Gripper Lineup

Name	Smallest slide type	Smallest lever type	Small slide type	Small long-stroke type	Medium slide type	Medium high-force slide type	Large high-force slide type
Model number	GRSS	GRLS	GRS	GRST	GRM	GRHM	GRHB
External View							
Opening/closing stroke (total of both sides)	8mm	180°	10mm	100mm	14mm	32mm	40mm
Maximum gripping force (N)	14	6.4	21	20/40	80	125	200
Maximum opening/closing speed (mm/s)	78	600	33.3	75/34	36.7	100	100
Allowable static load moment (N·m)	Ma	—	6.3	2.93	6.3	15.2	20.4
	Mb	0.5	—	6.3	2.93	6.3	34.3
	Mc	1.5	—	7	5	8.3	60.5
External dimensions (mm)	W	42	42	69	190	74	116
	H	24	36	30	33	36	44
	D	71	73	71	53.5	79	105
Mass (kg)	0.2	0.2	0.36	0.66	0.5	1.14	1.5

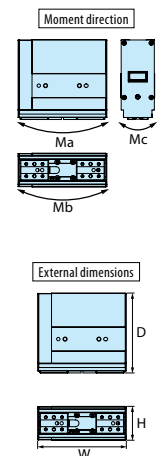

Model Specification Items

RCP2 - [] - 1 - [] - 2 - [] - [] - [] - []								
Series	Type	Encoder type	Motor type	Gear ratio	Opening/closing stroke	Applicable controller	Cable length	Options
	GRHM: Medium high-force type GRHB: Large high-force type	I: Incremental specification	3SP: Pulse motor, size 35□ 42P: Pulse motor, size 42□	2: Feed screw, lead 2	32: 32 mm (16 mm per side) 40: 40 mm (20 mm per side)	P1: PCON RPCON PSEL P3: PMEC PSEP	N: None P: 1 m S: 3 m M: 5 m X□□: Specified length	CJT: Optional cable exit direction (top) CJR: Optional cable exit direction (right) CJL: Optional cable exit direction (left) CJB: Optional cable exit direction (bottom) FB: Flange bracket SB: Shaft bracket

Actuators

Model number	Standard price
RCP2-GRHM-I-35P-2-32-□	—
RCP2-GRHB-I-42P-2-40-□	—

Options

Name	Option code	Standard price
Optional cable exit direction (top)	CJT	—
Optional cable exit direction (right)	CJR	—
Optional cable exit direction (left)	CJL	—
Optional cable exit direction (bottom)	CJB	—
Flange bracket	FB	—
Shaft bracket	SB	—

Cables

Type	Cable Symbol	Standard price
Standard type (robot cable)	P (1m)	—
	S (3m)	—
	M (5m)	—
Special length	X06 (6m) ~ X10 (10m)	—
	X11 (11m) ~ X15 (15m)	—
	X16 (16) ~ X20 (20m)	—

Applicable Controllers

Name	Model number	Standard price
Solenoid type (100-V specification)	PMEC-C-□-NP-2-1	—
Solenoid type (24-V specification)	PSEP-C-□-NP-2-0	—
Splash-proof solenoid type (24-V specification)	PSEP-CW-□-NP-2-0	—
Positioner type	PCON-C-□-NP-2-0	—
Field network type	RPCON-□	—
Program type	PSEL-C-1-□-NP-2-0	—

External Dimensions – Mounting Bracket

● RCP2-GRHM

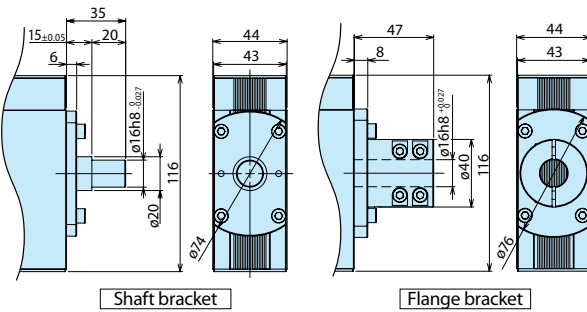

● RCP2-GRHB

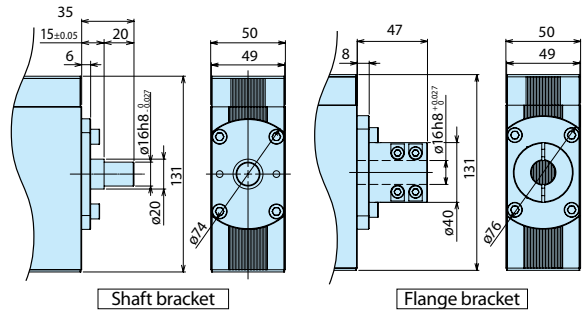

Selection Guideline

The maximum work part mass that can be transported varies depending on the coefficient of friction determined by the materials of the robot's finger and work part as well as on the shape of the work part. As a guide, the maximum work part mass should not be more than one-tenth to one-twentieth of the normal gripping force. Also, when a large acceleration/deceleration or impact is applied while the work part is transported, an allowance (one-thirtieth to one-fiftieth) must also be considered. The distance from the finger installation surface to the gripping point (L) shall conform to the applicable dimension shown to the right.

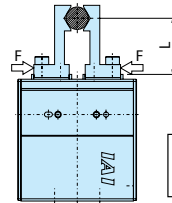

RCP2-GRHM ⇨ □ 90 mm max.
RCP2-GRHB ⇨ □ 90 mm max.

In push-motion operation, the gripping force (push force) can be adjusted within a range of 20 to 70% in current-limiting values of the controller.

● RCP2-GRHM

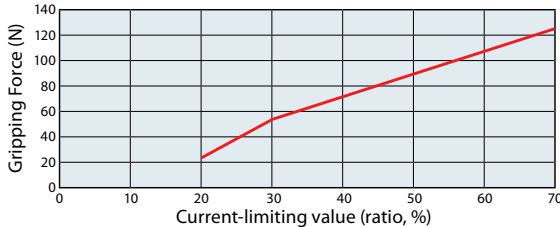

● RCP2-GRHB

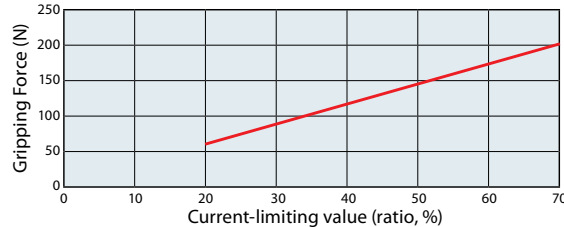

Caution

• Accuracy of the relationship between the push force (gripping force) and current-limiting value is not assured. The above graphs should only be used as a reference. Take note that if the push force is too small, the push force may vary or malfunction may result due to the slide resistance, etc. The current-limiting value should be at least 20%.

Note

• The finger should be as small and light as possible. If the finger is long, large or heavy, performance may drop or the guide may be negatively affected.

Specification Table

Type / Model number	Medium size high-force type GRHM	Large size high-force type GRHB
Opening/closing stroke	32 mm (16 mm per side)	40 mm (20 mm per side)
Maximum grip force (N)	125	200
Maximum opening/closing speed	100 mm/s (per side)	100mm/s (per side)
Positioning repeatability	±0.01mm	±0.01mm
Allowable static load moment (N·m)	Ma:15.2 Mb:21.7 Mc:60.5	Ma:20.4 Mb:34.3 Mc:77.8
Position detection method	Magnetic Encoder (incremental)	
Use environment	Temperature 0 to 40°C, humidity 20 to 85% RH or less (non-condensing)	
External dimensions (mm)	44 (D) × 116 (W) × 105 (L)	50 (D) × 131 (W) × 118 (H)
Mass (kg)	1.14	1.5

External Dimensions

