

- Slider Type
- Mini
- Standard
- Controllers Integrated
- Rod Type
- Mini
- Standard
- Controllers Integrated
- Table/Arm /Flat Type
- Mini
- Standard



**Program controller
For RCP3/RCP2 Series**

List of models

Program controller for operating RCP3 / RCP2 Series actuators. Various control functions are combined into a single unit.

Type	C	
Name	Program mode	Positioner Mode
External View		
Description	Both the actuator operation and communication with external equipment can be handled by a single controller. When two axes are connected, arc interpolation, path operations, and synchronization can be performed.	Up to 1500 positioning points are supported. Push-motion operation and teaching operation are also possible.
Position points	1500 points	
Maximum number of control axes	2	

- Gripper/ Rotary Type
- Linear Servo Type
- Cleanroom Type
- Splash-Proof
- Controllers**
- PMEC /AMEC
- PSEP /ASEP
- ROBO NET
- ERC2
- PCON
- ACON
- SCON

Model

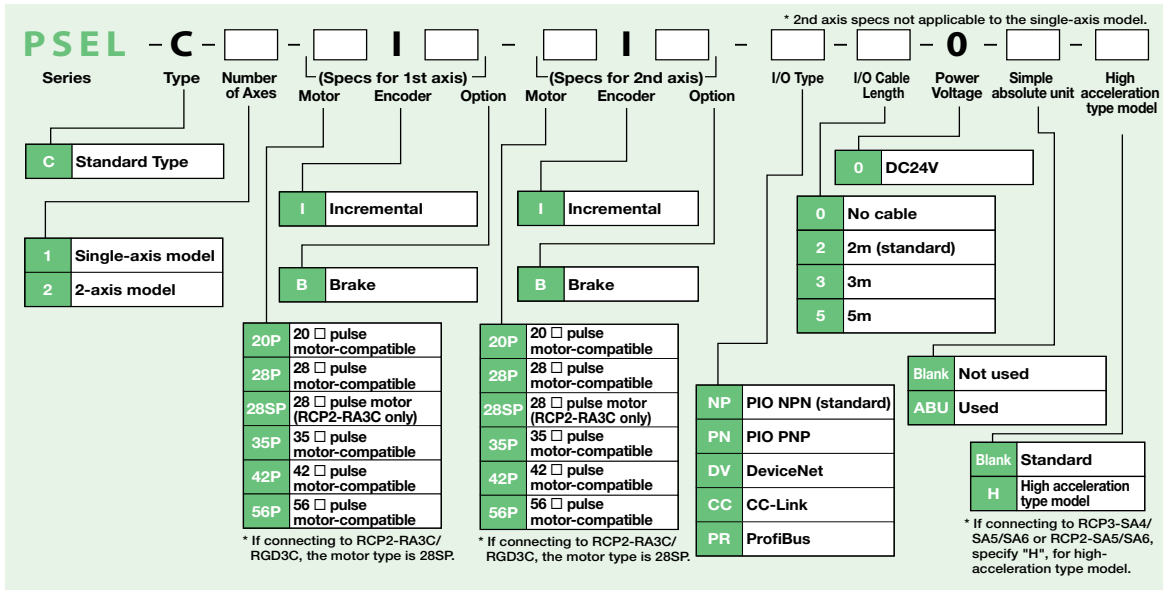

- Pulse Motor**
- Servo Motor (24V)
- Servo Motor (200V)
- Linear Servo Motor

557 PSEL

System configuration

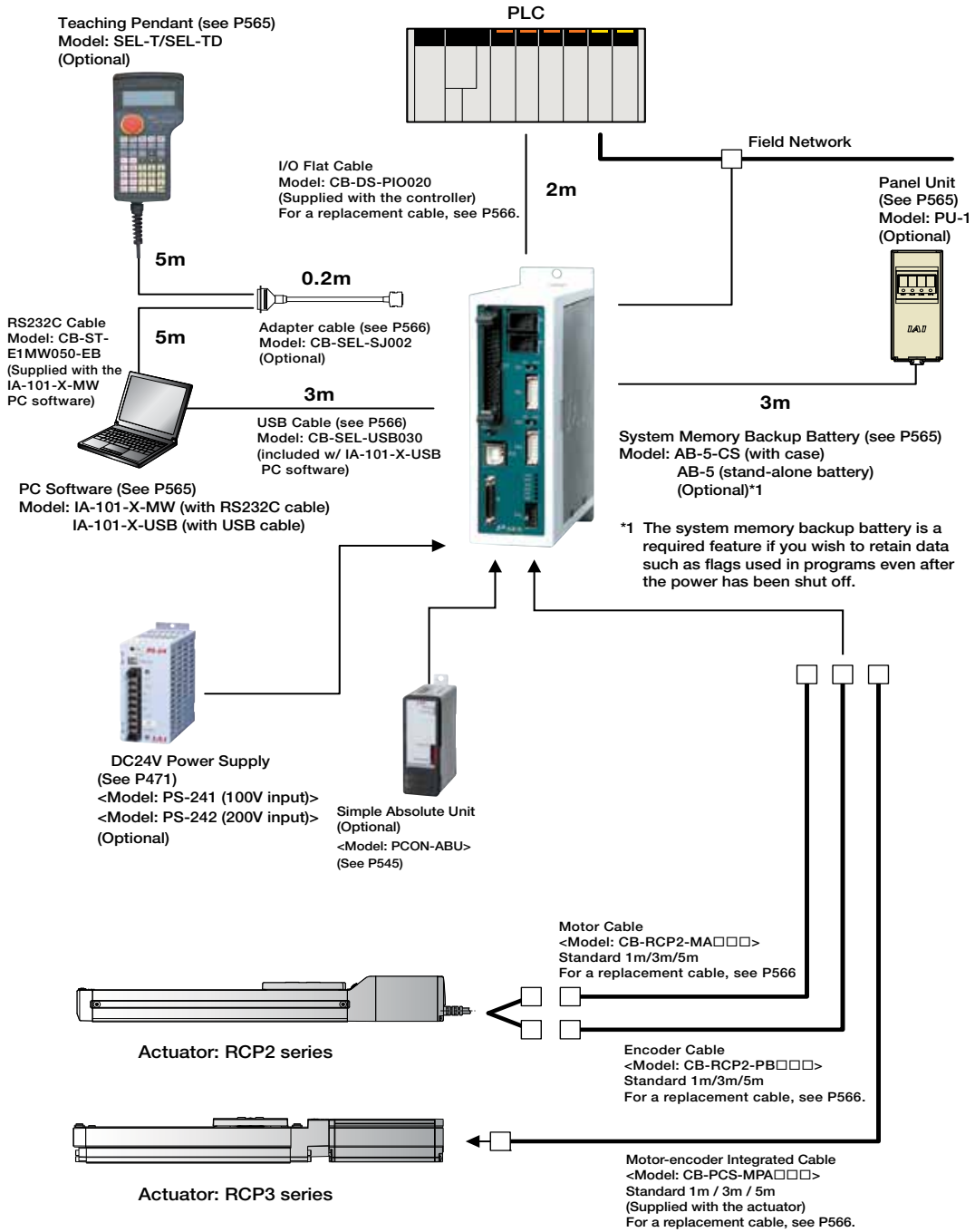

- Slider Type
- Mini
- Standard
- Controllers Integrated
- Rod Type
- Mini
- Standard
- Controllers Integrated
- Table/Arm /Flat Type
- Mini
- Standard
- Gripper/ Rotary Type
- Linear Servo Type
- Cleanroom Type
- Splash-Proof
- Controllers**
- PMEC /AMEC
- PSEP /ASEP
- ROBO NET
- ERC2
- PCON
- ACON
- SCON
- PSEL**
- ASEL
- SSEL
- XSEL
- Pulse Motor**
- Servo Motor (24V)
- Servo Motor (200V)
- Linear Servo Motor

I/O Specifications

Input section External input specifications

Item	Specifications
Input voltage	DC24V ±10%
Input current	7mA / circuit
ON/OFF voltage	ON voltage (min.) NPN : DC16V / PNP : DC8V OFF voltage (max.) NPN : DC5V / PNP : DC19V
Isolation method	Photocoupler

NPN Specifications

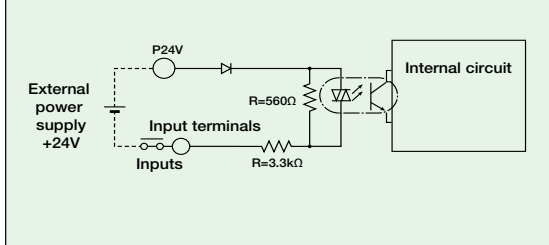

PNP Specifications

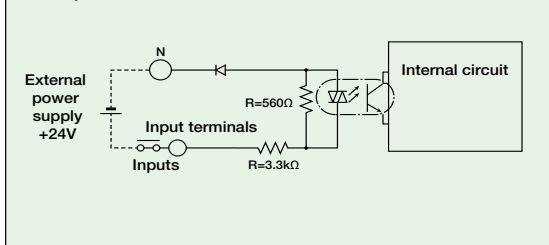

Output section External output specifications

Item	Specifications
Load Voltage	DC24V
Max. load current	100mA / 1 point 400mA / 8 points in total
Residual voltage (Max.)	Max 0.1mA / 1 point
Isolation method	Photocoupler

NPN Specifications

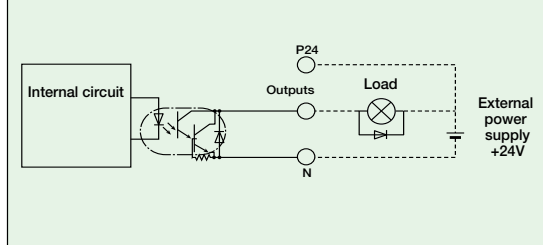

PNP Specifications

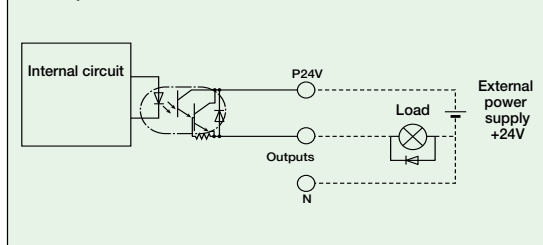

Explanation of I/O Signal Functions

Two modes can be selected for the SSEL controller: "Program Mode," in which the actuator is operated by entering a program, and "Positioner Mode," in which PLC signals are received and the actuator is moved to designated positions. The Positioner Mode has the five input patterns listed below to enable various applications.

Control Function by Type

Operation mode	Features
Program mode	Various operations including linear/arc interpolation operation, path operation ideal for coating processes, etc., arch-motion operation and palletizing operation can be performed using the Super SEL language that lets you program complex control actions using simple commands.
Positioner mode	Standard mode This is the basic mode from which operations can be conducted by designating position numbers and inputting the start signal. Push-motion operation and teaching operation are also possible.
	Product Change mode Multiple work parts of the same shape with slightly different hole positions can be handled using movement commands to the same position numbers by simply changing the product type number.
	2-axis independent mode With a 2-axis controller, each axis can be commanded and operated separately.
	Teaching mode In this mode, the slider (rod) moves based on an external signal, when the actuator is stopped, the current location can be registered as position data.
	DS-S-C1 Compatible mode If you were using a DS-S-C1 controller, you can replace it with a PSEL controller without having to change the host programs. *This mode does not ensure actuator compatibility.

- Slider Type
- Mini
- Standard
- Controllers Integrated
- Rod Type
- Mini
- Standard
- Controllers Integrated
- Table/Arm /Flat Type
- Mini
- Standard
- Gripper/ Rotary Type
- Linear Servo Type
- Cleanroom Type
- Splash-Proof
- Controllers
- PMEC /AMEC
- PSEP /ASEP
- ROBO NET
- ERC2
- PCON
- ACON
- SCON
- PSEL
- ASEL
- SSEL
- XSEL
- Pulse Motor
- Servo Motor (24V)
- Servo Motor (200V)
- Linear Servo Motor

Explanation of I/O Signal Functions

Program mode

Pin Number	Classification	Port No.	Program Mode	Functions	Wiring Diagram	
1A	P24	016	24V input	Connect 24V.		
1B			Select Program No. 1	Selects the program number to start. (Input as BCD values to ports 016 to 022)		
2A			Select Program No. 2			
2B			Select Program No. 4			
3A			Select Program No. 8			
3B			Select Program No. 10			
4A			Select Program No. 20			
4B			Select Program No. 40			
5A			CPU reset			Resets the system to the same state as when the power is turned on.
5B			Start			Starts the program selected by ports 016 to 022.
6A			General-purpose input			Waits for external input via program instructions.
6B			General-purpose input			
7A			General-purpose input			
7B	General-purpose input					
8A	General-purpose input					
8B	General-purpose input					
9A	General-purpose input					
9B	General-purpose input					
10A	General-purpose input					
10B	General-purpose input					
11A	General-purpose input	Turns off when an alarm occurs. (Contact B)				
11B	General-purpose input					
12A	General-purpose input					
12B	General-purpose input					
13A	General-purpose input					
13B	Alarm					
14A	Ready		Turns on when the controller starts up normally and is in an operable state.			
14B	General-purpose output	These outputs can be turned ON/OFF as desired via program instructions.				
15A	General-purpose output					
15B	General-purpose output					
16A	General-purpose output					
16B	General-purpose output					
17A	General-purpose output	Connect 0V.				
17B	0V input					

Note: This is for NPN. PNP will be different.

Positioner mode

Pin Number	Classification	Port No.	Positioner Standard Mode	Functions	Wiring Diagram	
1A	P24	016	24V input	Connect 24V.		
1B			Position input 10	Specifies the position numbers to move to, using port number 007 to 019. The number can be specified either as BCD or binary.		
2A			Position input 11			
2B			Position input 12			
3A			Position input 13			
3B			-			
4A			-			
4B			-			
5A			Error reset			Resets minor errors. (Severe errors require a restart.)
5B			Start			Starts moving to selected position.
6A			Home return			Performs home return.
6B			Servo ON			Switches between Servo ON and OFF.
7A			Push			Performs a push motion.
7B	Pause	Pauses the motion when turned OFF, and resumes when turned ON.				
8A	Cancel	Stops the motion when turned OFF. The remaining motion is canceled.				
8B	Interpolation settings	When this signal is turned ON for a 2-axis model, the actuator moves by linear interpolation.				
9A	Position input 1	Specifies the position numbers to move to, using ports 007 to 019. The number can be specified either as BCD or binary.				
9B	Position input 2					
10A	Position input 3					
10B	Position input 4					
11A	Position input 5					
11B	Position input 6					
12A	Position input 7					
12B	Position input 8	Turns off when an alarm occurs. (Contact B)				
13A	Position input 9					
13B	Alarm					
14A	Ready		Turns on when the controller starts up normally and is in an operable state.			
14B	Positioning complete		Turns on when the movement to the destination is complete.			
15A	Home return complete	Turns on when the home return operation is complete.				
15B	Servo ON output	Turns on when servo is ON.				
16A	Pushing complete	Turns on when a push motion is complete.				
16B	System battery error	Turns on when the system battery runs low (warning level).				
17A	-	Connect 0V.				
17B	0V input					

Note: This is for NPN. PNP will be different.

- Slider Type
- Mini
- Standard
- Controllers Integrated
- Rod Type
- Mini
- Standard
- Controllers Integrated
- Table/Arm /Flat Type
- Mini
- Standard
- Cripper/ Rotary Type
- Linear Servo Type
- Cleanroom Type
- Splash-Proof
- Controllers
- PMEC /AMEC
- PSEP /ASEP
- ROBO NET
- ERC2
- PCON
- ACON
- SCON
- PSEL
- ASEL
- SSEL
- XSEL
- Pulse Motor
- Servo Motor (24V)
- Servo Motor (200V)
- Linear Servo Motor

PSEL 560

Explanation of I/O Signal Functions

Positioner, Product-Type Change Mode

Pin Number	Classification	Port No.	Positioner Product Type Change Mode	Functions		
1A	P24	/	24V input	Connect 24V.		
1B			016	Position/Product Type Input 10	Specifies the position numbers to move to, and the product type numbers, using ports 007 to 022. The position and product type numbers are assigned by parameter settings. The number can be specified either as BCD or binary.	
2A			017	Position/Product Type Input 11		
2B			018	Position/Product Type Input 12		
3A			019	Position/Product Type Input 13		
3B			020	Position/Product Type Input 14		
4A			021	Position/Product Type Input 15		
4B			022	Position/Product Type Input 16		
5A			023	Error reset		Resets minor errors. (Severe errors require a restart.)
5B			000	Start		Starts moving to selected position.
6A			001	Home return		Performs home return.
6B			002	Servo ON		Switches between Servo ON and OFF.
7A			003	Push		Performs a push motion.
7B			004	Pause		Pauses the motion when turned OFF, and resumes when turned ON.
8A			005	Cancel		Stops the motion when turned OFF. The remaining motion is canceled.
8B			006	Interpolation settings		When this signal is turned ON for a 2-axis model, the actuator moves by linear interpolation.
9A	007	Position/Product Type Input 1	Specifies the position numbers to move to, and the product type numbers, using ports 007 to 022. The position and product type numbers are assigned by parameter settings. The number can be specified either as BCD or binary.			
9B	008	Position/Product Type Input 2				
10A	009	Position/Product Type Input 3				
10B	010	Position/Product Type Input 4				
11A	011	Position/Product Type Input 5				
11B	012	Position/Product Type Input 6				
12A	013	Position/Product Type Input 7				
12B	014	Position/Product Type Input 8				
13A	015	Position/Product Type Input 9				
13B	300	Alarm		Turns off when an alarm occurs. (Contact B)		
14A	301	Ready		Turns on when the controller starts up normally and is in an operable state.		
14B	302	Positioning complete		Turns on when the movement to the destination is complete.		
15A	303	Home return complete		Turns on when the home return operation is complete.		
15B	304	Servo ON output		Turns on when servo is ON.		
16A	305	Pushing complete		Turns on when a push motion is complete.		
16B	306	System battery error		Turns on when the system battery runs low (warning level).		
17A	307	-	-			
17B	N	/	0V input	Connect 0V.		

Wiring Diagram

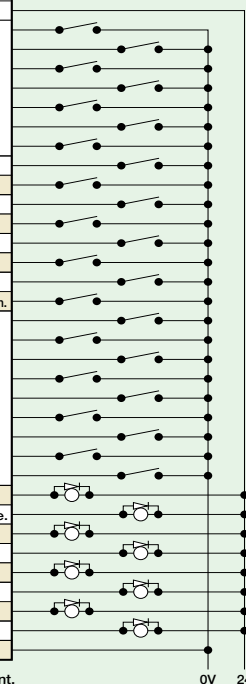

Note: This is for NPN. PNP will be different.

Positioner, 2-axis Independent Mode

Pin Number	Classification	Port No.	Positioner 2-axis Independent Mode	Functions		
1A	P24	/	24V input	Connect 24V.		
1B			016	Position input 7	Specifies the position numbers to move to, using ports 010 to 022. The position numbers on the 1st and 2nd axes are assigned by parameter settings. The number can be specified either as BCD or binary.	
2A			017	Position input 8		
2B			018	Position input 9		
3A			019	Position input 10		
3B			020	Position input 11		
4A			021	Position input 12		
4B			022	Position input 13		
5A			023	Error reset		Resets minor errors. (Severe errors require a restart.)
5B			000	Start 1		Starts the movement to the selected position number on the 1st axis.
6A			001	Home return 1		Performs home return on the 1st axis.
6B			002	Servo ON 1		Switches between servo ON and OFF for the 1st axis.
7A			003	Pause 1		Pauses the motion on 1st axis when turned OFF, and resumes when turned ON.
7B			004	Cancel 1		Cancels the movement on the 1st axis.
8A			005	Start 2		Starts the movement to the selected position number on the 2nd axis.
8B			006	Home return 2		Performs home return on the 2nd axis.
9A	007	Servo ON 2	Switches between servo ON and OFF for the 2nd axis.			
9B	008	Pause 2	Pauses the motion on 2nd axis when turned OFF, and resumes when turned ON.			
10A	009	Cancel 2	Cancels the movement on the 2nd axis.			
10B	010	Position input 1	Specifies the position numbers to move to, using ports 010 to 022. The position numbers on the 1st and 2nd axes are assigned by parameter settings. The number can be specified either as BCD or binary.			
11A	011	Position input 2				
11B	012	Position input 3				
12A	013	Position input 4				
12B	014	Position input 5				
13A	015	Position input 6				
13B	300	Alarm		Turns off when an alarm occurs. (Contact B)		
14A	301	Ready		Turns on when the controller starts up normally and is in an operable state.		
14B	302	Positioning complete 1		Turns on when the movement to the specified position on the 1st axis is complete.		
15A	303	Home return complete 1		Turns on when home return on the 1st axis is complete.		
15B	304	Servo ON output 1		Turns on when the 1st axis is in a servo ON state.		
16A	305	Positioning complete 2		Turns on when the movement to the specified position on the 2nd axis is complete.		
16B	306	Home return complete 2		Turns on when home return on the 2nd axis is complete.		
17A	307	Servo ON output 2		Turns on when the 2nd axis is in a servo ON state.		
17B	N	/		0V input	Connect 0V.	

Wiring Diagram

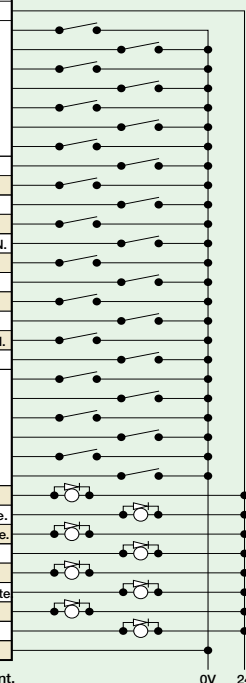

Note: This is for NPN. PNP will be different.

561 PSEL

- Slider Type
- Mini
- Standard
- Controllers Integrated
- Rod Type
- Mini
- Standard
- Controllers Integrated
- Table/Arm /Flat Type
- Mini
- Standard
- Gripper/ Rotary Type
- Linear Servo Type
- Cleanroom Type
- Splash-Proof
- Controllers
- PMEC /AMEC
- PSEP /ASEP
- ROBO NET
- ERC2
- PCON
- ACON
- SDON
- PSEL
- ASEL
- SSEL
- XSEL
- Pulse Motor
- Servo Motor (24V)
- Servo Motor (200V)
- Linear Servo Motor

Explanation of I/O Signal Functions

Positioner, Teaching Mode

Pin Number	Classification	Port No.	Positioner Teaching Mode	Functions	Wiring Diagram	
1A	P24		24V input	Connect 24V.		
1B		016	JOG- on 1st axis	While the signal is on, the 1st axis is moved in the - (negative) direction.		
2A		017	JOG+ on 2nd axis	While the signal is on, the 2nd axis is moved in the + (positive) direction.		
2B		018	JOG- on 2nd axis	While the signal is on, the 2nd axis is moved in the - (negative) direction.		
3A		019	Specify inching (0.01mm)	Specifies how much to move during inching. (Total of the values specified for ports 019 to 022)		
3B		020	Specify inching (0.1mm)			
4A		021	Specify inching (0.5mm)			
4B		022	Specify inching (1mm)			
5A		023	Error reset	Resets minor errors. (Severe errors require a restart.)		
5B		000	Start	Starts moving to selected position.		
6A		001	Servo ON	Switches between Servo ON and OFF.		
6B		002	Pause	Pauses the motion when turned OFF, and resumes when turned ON.		
7A		Input	003	Position input 1		Ports 003 to 013 are used to specify the position number to move, and the position number for inputting the current position. - When the teaching mode setting on port 014 is in the ON state, the current value is written to the specified position number.
7B			004	Position input 2		
8A			005	Position input 3		
8B			006	Position input 4		
9A			007	Position input 5		
9B	008		Position input 6			
10A	009		Position input 7			
10B	010		Position input 8			
11A	011		Position input 9			
11B	012		Position input 10			
12A	013		Position input 11			
12B	014	Teaching mode setting				
13A	015	JOG+ on 1st axis	While the signal is on, the 1st axis is moved in the + (positive) direction.			
13B	300	Alarm	Turns off when an alarm occurs. (Contact B)			
14A	301	Ready	Turns on when the controller starts up normally and is in an operable state.			
14B	302	Positioning complete	Turns on when the movement to the destination is complete.			
15A	303	Home return complete	Turns on when the home return operation is complete.			
15B	304	Servo ON output	Turns on when servo is ON.			
16A	305	-	-			
16B	306	System battery error	Turns on when the system battery runs low (warning level).			
17A	307	-	-			
17B	N		0V input	Connect 0V.		

Note: This is for NPN. PNP will be different.

Positioner, DS-S-C1 Compatible Mode

Pin Number	Classification	Port No.	Positioner DS-S-C1 Compatible Mode	Functions	Wiring Diagram
1A	P24		24V input	Connect 24V.	
1B		016	Position No. 1000	(Same as ports 004 through 015)	
2A		017	-	-	
2B		018	-	-	
3A		019	-	-	
3B		020	-	-	
4A		021	-	-	
4B		022	-	-	
5A		023	CPU reset	Resets the system to the same state as when the power is turned on.	
5B		000	Start	Starts moving to selected position.	
6A		001	Hold (Pause)	Pauses the motion when turned ON, and resumes when turned OFF.	
6B		002	Cancel	Stops the motion when turned ON. The remaining motion is canceled.	
7A		003	Interpolation settings	When this signal is turned ON for a 2-axis model, the actuator moves by linear interpolation.	
7B		004	Position No. 1	Ports 004 through 016 are used to specify the position number to move. The numbers are specified as BCD.	
8A		005	Position No. 2		
8B		006	Position No. 4		
9A		007	Position No. 8		
9B	008	Position No. 10			
10A	009	Position No. 20			
10B	010	Position No. 40			
11A	011	Position No. 80			
11B	012	Position No. 100			
12A	013	Position No. 200			
12B	014	Position No. 400			
13A	015	Position No. 800			
13B	300	Alarm	Turns off when an alarm occurs. (Contact A)		
14A	301	Ready	Turns on when the controller starts up normally and is in an operable state.		
14B	302	Positioning complete	Turns on when the movement to the destination is complete.		
15A	303	-	-		
15B	304	-	-		
16A	305	-	-		
16B	306	System battery error	Turns on when the system battery runs low (warning level).		
17A	307	-	-		
17B	N		0V input	Connect 0V.	

Note: This is for NPN. PNP will be different.

- Slider Type
- Mini
- Standard
- Controllers Integrated
- Rod Type
- Mini
- Standard
- Controllers Integrated
- Table/Arm /Flat Type
- Mini
- Standard
- Gripper/ Rotary Type
- Linear Servo Type
- Cleanroom Type
- Splash-Proof
- Controllers
- PMEC /AMEC
- PSEP /ASEP
- ROBO NET
- ERC2
- PCON
- ACON
- SCON
- PSEL
- ASEL
- SSEL
- XSEL
- Pulse Motor
- Servo Motor (24V)
- Servo Motor (200V)
- Linear Servo Motor

Table of specifications

	Item	Specifications
Basic Specifications	Connected actuator	RCP2 series actuator (Note 1)
	Input voltage	DC24V ±10%
	Power Supply Capacity	Control power (Max. 1.2A) + Motor power (See the table below)
	Dielectric strength voltage	DC500V 10MΩ or higher
	Withstand voltage	AC500V 1 min.
	Rush current	Max. 30A
Control specification	Vibration resistance	XYZ directions 10 to 57Hz, One side amplitude: 0.035mm (continuous), 0.075mm (intermittent) 58 to 150 Hz 4.9 m/s ² (continuous), 9.8 m/s ² (intermittent)
	Maximum total output of connected axis	-
Program	Position detection method	Incremental encoder
	Speed setting	From 1mm/s. The maximum limit varies depending on the actuator.
	Acceleration setting	From 0.01G. The maximum limit varies depending on the actuator.
	Operating method	Program operation / Positioner operation (switchable)
	Programming language	Super SEL language
	Number of programs	64 programs
	Number of program steps	2000 steps
	Number of multi-tasking programs	8 programs
	Positioning Points	1500 points
	Data memory device	FLASHROM (A system-memory backup battery can be added as an option)
Communication	Data input method	Teaching pendant or PC software
	Number of I/O	24 input points / 8 output points (NPN or PNP selectable)
	I/O power	Externally supplied 24VDC ± 10%
	PIO cable	CB-DS-PIO □□□ (supplied with the controller)
	Serial communications function	RS232C (Half-pitch connector) / USB connector
	Field Network	DeviceNet, CC-Link, ProfiBus
General specifications	Motor Cable	CB-RCP2-MA □□□ (Max. 20m)
	Encoder cable	CB-RCP2-PA □□□ (Max. 20m)
	Protection function	Motor driver temperature check, Encoder open-circuit check Soft limit over, system error, battery error, etc.
	Ambient operating humidity and temperature	0 to 40°C 10 to 95% (non-condensing)
	Ambient atmosphere	Free from corrosive gases. In particular, there shall be no significant powder dust.
	Protection class	IP20
Weight	Approx. 450g	
External dimension	43 mm (W) x 159 mm (H) x 110 mm (D)	

(Note 1) Cannot operate High-Thrust type (RA10C), High-Speed type (HS8C/HS8R), or Waterproof type (RCP2W-SA16).

Motorpower supply Capacity (Note2)	Motor type	1-Axis specifications		2-Axis specifications	
		Rated	Max.(Note 3)	Rated	Max.(Note 3)
	20P, 28P, 28SP motor	0.4A	2.0A	0.8A	4.0A
	35P, 42P, 56SP motor	1.2A		2.4A	

(Note 2) For both 1-axis and 2-axis specifications, approx. 30A inrush current flows for 5 ms when the control power supply is turned on.

(Note 3) After Servo ON, excitation detection is performed. In that case, the current is maximized. (Approx. 100 msec)

However, if motor drive power supply is turned on after a shut-down, approx. 6.0A and approx. 12.0A current flows to axis-1 and axis-2 respectively. (Approx. 1 to 2 msec)

Exterior dimensions

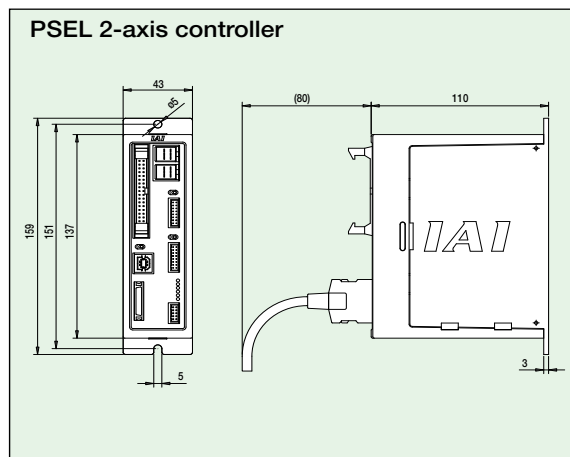
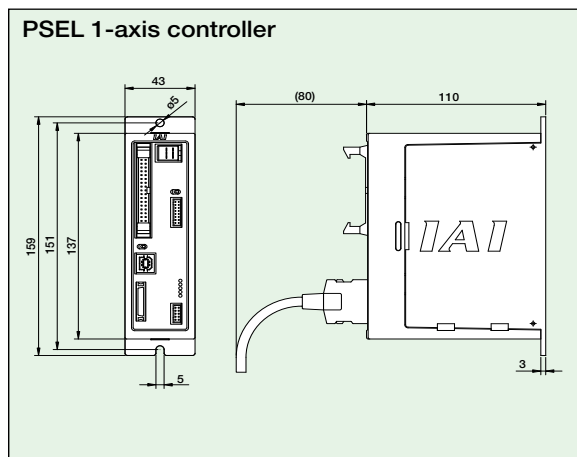

563 PSEL

- Slider Type
- Mini
- Standard
- Controllers Integrated
- Rod Type
- Mini
- Standard
- Controllers Integrated
- Table/Arm /Flat Type
- Mini
- Standard
- Gripper/ Rotary Type
- Linear Servo Type
- Cleanroom Type
- Splash-Proof
- Controllers
- PMEC /AMEC
- PSEP /ASEP
- ROBO NET
- ERC2
- PCON
- ACON
- SCON
- PSEL
- ASEL
- SSEL
- XSEL
- Pulse Motor
- Servo Motor (24V)
- Servo Motor (200V)
- Linear Servo Motor

Name of Each Part

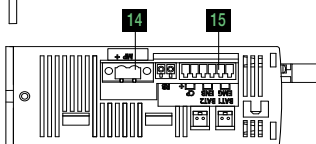
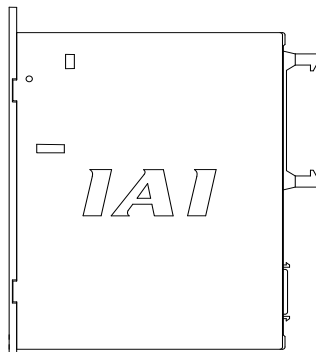
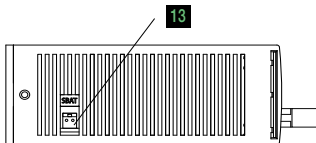
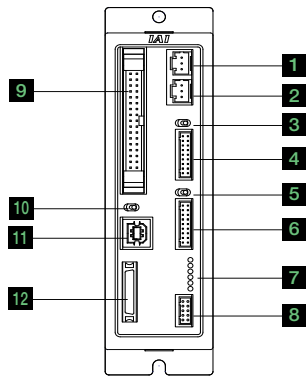

1 Motor connector for axis 1

Connects the motor cable of the axis 1 actuator.

2 Motor connector for axis 2

Connects the motor cable of the axis 2 actuator.

3 Brake switch for axis 1

This switch is used to release the axis brake. Setting it to the left position (RLS side) forcibly releases the brake, while setting it to the right position (NOM side) causes the controller to automatically control the brake.

4 Encoder connector for axis 1

Connect the encoder cable of the axis 1 actuator.

5 Brake switch for axis 2

This switch is used to release the axis brake. Setting it to the left position (RLS side) forcibly releases the brake, while setting it to the right position (NOM side) causes the controller to automatically control the brake.

6 Encoder connector for axis 2

Connect the encoder cable of the axis 2 actuator.

7 Status indicator LEDs

These LEDs are used to indicate the operating condition of the controller.

The LED status indicators are as follows:

- PWR : Power is input to controller.
- RDY : The controller is ready to perform program operation.
- ALM : The controller is abnormal.
- EMG : An emergency stop is actuated and the drive source is cut off.
- SV1 : The axis 1 actuator servo is on.
- SV2 : The axis 2 actuator servo is on.

8 Panel unit connector

A connector for the panel unit (optional) that displays the controller status and error codes.

9 I/O Connector

A connector for interface I/Os.

34-pin flat cable connector for DIO (24IN/8OUT) interface.

I/O power is also supplied to the controller via this connector (Pin No. 1 and No. 34).

10 Mode switch

This switch is used to specify the running mode of the controller. The left position indicates the MANU (manual operation) mode, while the right position indicates the AUTO (automatic operation) mode. Teaching can only be performed in manual operation, and automatic operation using external I/Os is not possible in the MANU mode.

11 USB connector

A connector for PC connection via USB. If the USB connector is connected, the TP connector is disabled and all communication inputs to the TP connector are cut off.

12 Teaching pendant connector

A half-pitch I/O 26-pin connector that connects a teaching pendant when the running mode is MANU. A special conversion cable is needed to connect a conventional D-sub, 25-pin connector.

13 System-memory backup battery connector

If you wish to retain the various data recorded in the SRAM of the controller even after the power is cut off, connect the necessary battery to this connector. This battery is installed externally to the unit. The controller does not come standard with the battery (Option).

14 Motor power input connector

This connector is used to input the motor power. It consists of a 2-pin, 2-piece connector by Phoenix Contact.

15 Control power/System input connector

This connector is used to connect the control power input, emergency stop switch, and enable switch. It consists of a Phoenix Contact 6-pin 2-piece connector.

- Slider Type
- Mini
- Standard
- Controllers Integrated
- Rod Type
- Mini
- Standard
- Controllers Integrated
- Table/Arm /Flat Type
- Mini
- Standard
- Cripper/ Rotary Type
- Linear Servo Type
- Cleanroom Type
- Splash-Proof
- Controllers
- PMEC /AMEC
- PSEP /ASEP
- ROBO NET
- ERC2
- PCON
- ACON
- SCON
- PSEL
- ASEL
- SSEL
- XSEL

- Pulse Motor
- Servo Motor (24V)
- Servo Motor (200V)
- Linear Servo Motor

Option

Teaching Pendant

Features This is a teaching device that provides information on functions such as position input, test runs, and monitoring.

Model

Model	Description
SEL-T-J	Standard type with adapter cable
SEL-TD-J	Equipped with a deadman switch and adapter cable

Configuration

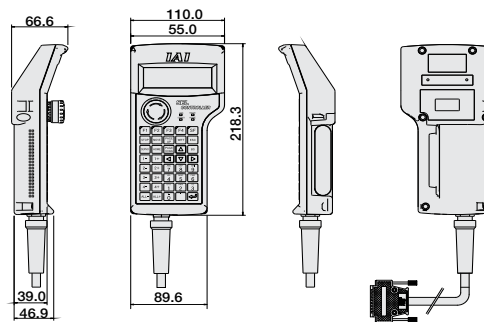
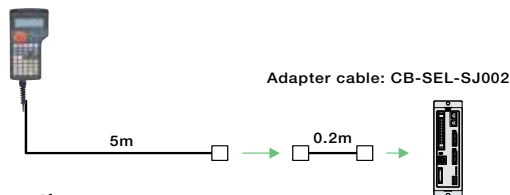

Specifications

Item	SEL-T-J	SEL-TD-J
3-position Enable Switch	No	Yes
ANSI/UL standards	Non-compliant	Compliant
CE mark	Compliant	
Display	20 char. x 4 lines	
Ambient Operating Temp./Humidity	0~40°C 10~90% RH (non-condensing)	
Protective structure	IP54	
Weight	Approx. 0.4kg (not incl. cable)	

SEL-T option

- Wall-mounting hook Model HK-1
- Strap Model STR-1

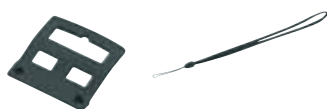

PC Software (Windows Only)

Features A startup support software for inputting programs/positions, performing test runs, and monitoring. More functions have been added for debugging, and improvements have been made to shorten the start-up time.

Model IA-101-X-MW-J (with RS232C cable + adapter cable)

Configuration

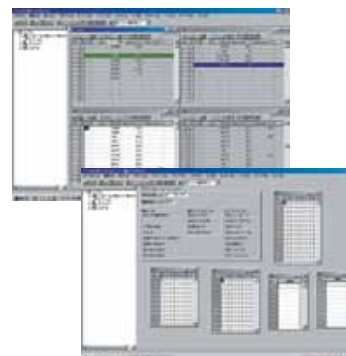
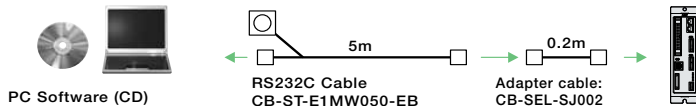

Model IA-101-X-USB (with USB cable)

Configuration

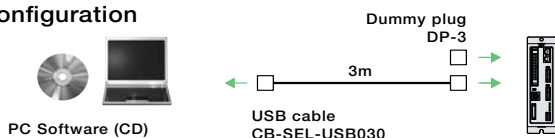

Note:
Only versions 7.0.0.0 and later can be used with the PSEL controller.

Panel Unit

Features Display device that shows the error code from the controller or the currently running program number.

Model PU-1 (Cable length: 3m)

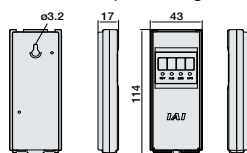

System Memory Backup Battery

Features This battery is required when you are using global flags in the program and you want to retain your data even after the power has been turned OFF.

Model AB-5-CS (with case)
AB-5 (stand-alone battery)



Dummy Plug

Features When connecting the PSEL controller to a computer with a USB cable, this plug is inserted in the teaching port to shut off the enable circuit. (Supplied with the PC software IA-101-X-USB)

Model DP-3



565 PSEL

Option

USB Cable

- Features** A cable for connecting the controller to the USB port to a computer. A controller with no USB port (e.g. XSEL) can be connected to the USB port of a computer by connecting an RS232C cable to the USB cable via a USB adapter. (See PC software IA-101-X-USBMW)
- Model** **CB-SEL-USB030** (Cable length: 3m)



Adapter Cable

- Features** An adapter cable to connect the D-sub 25-pin connector from the teaching pendant or a PC to the teaching connector (half-pitch) of the PSEL controller.
- Model** **CB-SEL-SJ002** (Cable length: 0.2m)



Spare Parts

When you need spare parts after purchasing the product, such as when replacing a cable, refer to the list of models below.

Motor cable

Model **CB-RCP2-MA** ** The standard cable for the motor cable is the robot cable. * Enter the cable length (L) into . Compatible to a maximum of 20 meters. Ex.: 080 = 8 m

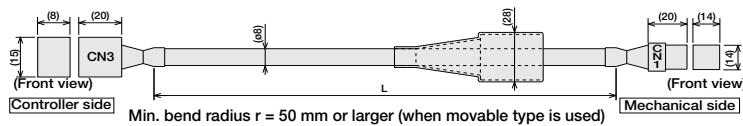

Wire	Color	Signal	Pin No.	Pin No.	Signal	Color	Wire
Orange	A	A1	1	A	Yellow	SLP-06V	(JST)
Gray	VMM	A2	2	VMM	Gray		
White	B	A3	3	A	Orange		
Yellow	A	B1	4	B	Orange (Black 3)		
Pink	VMM	B2	5	VMM	Pink		
Orange (Black 1)	B	B3	6	B	White		

Encoder cable/Encoder robot cable

Model **CB-RCP2-PB** / **CB-RCP2-PB** -**RB** * The standard cable for the encoder cable is a normal cable. * Enter the cable length (L) into . Compatible to a maximum of 20 meters. A robot cable can be specified as an option. Ex.: 080 = 8 m

Min. bend radius $r = 50$ mm or larger (when movable type is used)
* Only robot cable is to be used in a cable track.

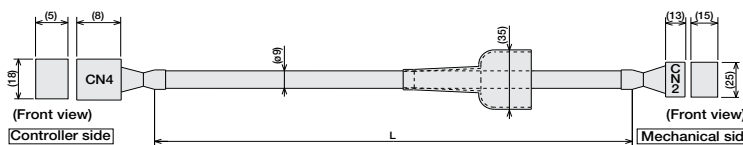

Cable color	Signal	Pin No.	Pin No.	Signal	Cable color	C N 2
Blue (Red 1)	Orange (Black 2), S +	16	1	E N A	Brown	Light Gray (Red 1)
White	Orange (Red 2), S -	15	2	E N A	Green	Light Gray (Red 1)
Red	Orange (Red 1), K +	14	3	E N B	Purple	White (Red 1)
Gray	Orange (Red 1), E N A	12	4	E N B	Pink	White (Red 1)
Green	Light Gray (Red 1), E N A	11	5	---	---	---
Purple	White (Black 1), E N B	10	6	---	---	---
Pink	White (Red 1), E N B	9	7	---	---	---
Yellow	White (Black 1), E N B	8	8	---	---	---
Orange	Pink (Red 1), V B B	6	9	---	---	---
Blue	Pink (Black 1), GND	5	10	V B B	Orange	Pink (Red 1)
---	---	---	11	V P S	Yellow	Yellow (Black 1)
---	---	---	12	---	---	---
---	---	---	13	LS +	Blue (Red 1)	Orange (Red 2)
---	---	---	14	LS -	White	Orange (Red 2)
---	---	---	15	BK +	Red	Orange (Black 1)
---	---	---	16	BK -	Gray	Orange (Red 1)
---	---	---	17	BK -	Gray	Orange (Red 1)
---	---	---	18	F.G.	Ground	Ground

Motor-Encoder Integrated Cable for RCP3

Model **CB-PCS-MPA** * Enter the cable length (L) into . Compatible to a maximum of 20 meters. Ex.: 080 = 8 m

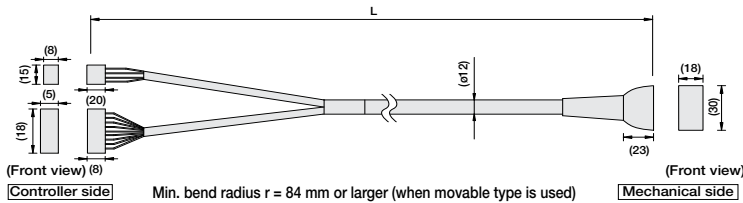

Signal	Pin Number	Wire color	Pin Number	Signal
A	B1	Black	A1	A
VMM	A2	White	B1	VMM
/A	A1	Red	A2	/A
B	B3	Green	B2	B
VMM	B2	Yellow	A3	VMM
/B	A3	Brown	B3	/B
---	---	---	B4	NC
---	---	---	A4	NC
BK+	14	Pink (Red +)	A5	BK+
BK-	15	Pink (Blue +)	B5	BK-
LS+	16	White (Red +)	A6	LS+
LS-	15	White (Blue +)	B6	LS-
A+	12	Orange (Red +)	A7	A+
A-	11	Orange (Blue +)	B7	A-
B+	10	Gray (Red +)	A8	B+
B-	9	Gray (Blue +)	B8	B-
NC	8	---	A9	NC
VCC	7	---	B9	VPS
GND	6	Orange (Blue + Contiguous)	A10	VCC
FG	5	Gray (Red + Contiguous)	B10	GND
---	---	---	A11	NC
---	---	---	B11	FG

I/O Flat Cable

Model **CB-DS-PIO** * Enter the cable length (L) into . Compatible to a maximum of 10 meters. Ex.: 080 = 8 m

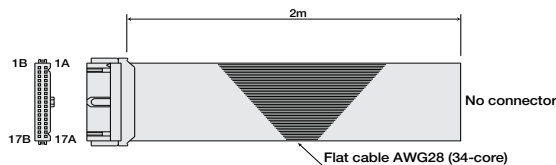

Pin No.	Color	Wire	Pin No.	Color	Wire
1A	Brown 1	---	9B	Gray 2	---
1B	Red 1	---	10A	White 2	---
2A	Orange 1	---	10B	Black 2	---
2B	Yellow 1	---	11A	Brown-3	---
3A	Green 1	---	11B	Red 3	---
3B	Blue 1	---	12A	Orange 3	---
4A	Purple 1	---	12B	Yellow 3	---
4B	Gray 1	---	13A	Green 3	---
5A	White 1	---	13B	Blue 3	---
5B	Black 1	---	14A	Purple 3	---
6A	Brown-2	---	14B	Gray 3	---
6B	Red 2	---	15A	White 3	---
7A	Orange 2	---	15B	Black 3	---
7B	Yellow 2	---	16A	Brown-4	---
8A	Green 2	---	16B	Red 4	---
8B	Blue 2	---	17A	Orange 4	---
9A	Purple 2	---	17B	Yellow 4	---

- Slider Type
- Mini
- Standard
- Controllers Integrated
- Robot Type
- Mini
- Standard
- Controllers Integrated
- Table/Arm /Flat Type
- Mini
- Standard
- Controller Integrated
- Gripper/ Rotary Type
- Linear Servo Type
- Cleanroom Type
- Splash-Proof
- Controllers
- PMEC /AMEC
- PSEP /ASEP
- ROBO NET
- ERC2
- PCON
- ACON
- SCON
- PSEL
- ASEL
- SSEL
- XSEL
- Pulse Motor
- Servo Motor (24V)
- Servo Motor (200V)
- Linear Servo Motor