

High-speed Cartesian Robot **CT4**

CT4
CARTESIAN 4

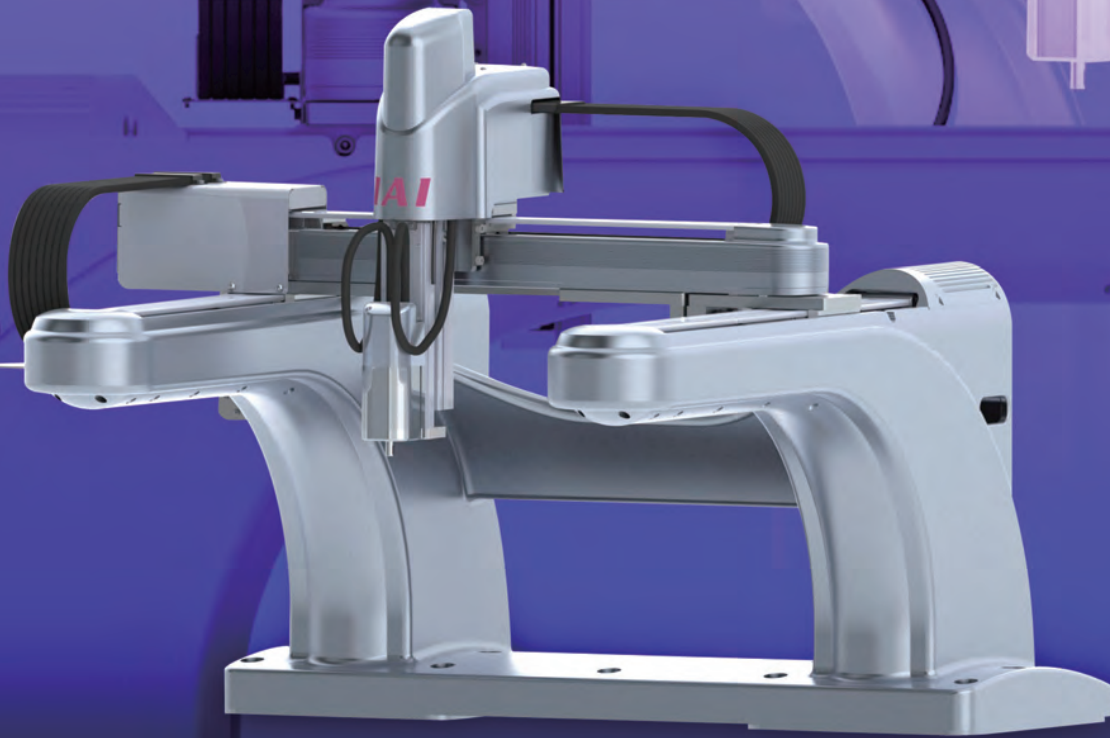

High-speed Cartesian Robot That Shortens Assembly/Inspection Cycle Times by Operating at High Speed, Ensuring High Rigidity and Demonstrating Excellent Straight Moving Performance

High-speed operation with commanded acceleration of up to **3.2 G**
(maximum instantaneous acceleration: 4.8 G)

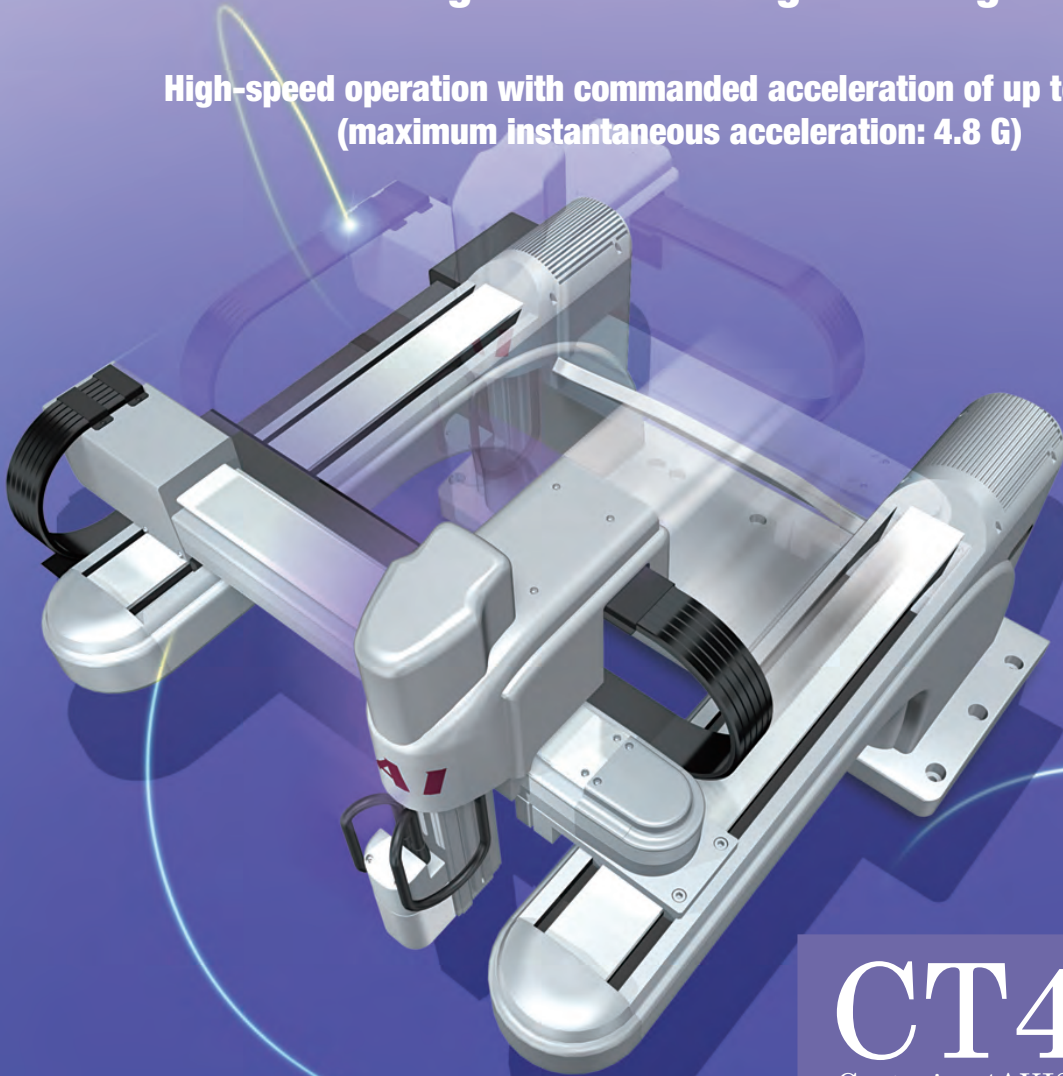

CT4
Cartesian4AXIS

Function Comparison Table of High-speed Cartesian Robot

	High-speed Cartesian Robot CT4	Multi-jointed robot	Parallel-link robot
1. Speed, acceleration/deceleration	◎	○	◎
2. Rigidity	◎	○	○
3. Robot size and operating range	◎	○	○
4. Straight moving performance	◎	△	△

1

Note) The evaluations under “Multi-jointed robot” and “Parallel-link robot” are based on IAI’s evaluations of standard robots.
◎: Good / ○: Average / △: Not very good

1 | Rotational Axis Specification: Newest Addition to the Series

You can now specify a CT4 robot having an ultra-compact rotational axis installed at the end of the vertical axis. The rotational axis lets you change the moving or aligning direction of the work, thereby expanding the scope of applications of the CT4 series further.

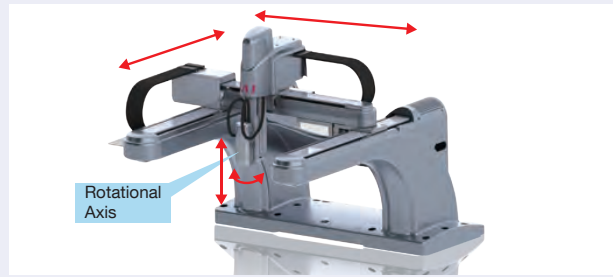

2 | High Speed & High Acceleration/Deceleration

Shorten the cycle time of your equipment by operating at the maximum speed of **2500 mm/s** and maximum acceleration of **3.2 G**.

The standard cycle time (Note) is 32% less than a conventional Cartesian robot.

(Note) The standard cycle time represents the time required for going back and forth along the path shown to the right, consisting of a vertical movement of 25 mm, horizontal movement of 200 mm and turning of 180 degrees.

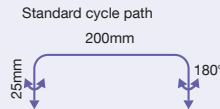

Comparison of Standard Cycle Times

IAI's Cartesian robot
Acceleration/
deceleration: 1.2 G

1 cycle: 0.558 sec

IAI's CT4
High-speed
Cartesian robot
Acceleration/
deceleration: 3.2 G

1 cycle: 0.379 sec

← 32% shorter

3 | Efficient Operation Range

A wide operation range of 400 mm (X-axis) x 300 mm (Y-axis) is ensured. Square operation ranges have no wasteful space and are more efficient compared to those of multi-jointed robots and parallel-link robots that can only operate in circles due to their structure.

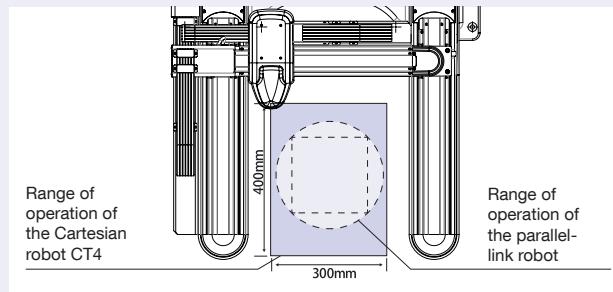

4 | High Rigidity, Easy to Install

Boasting high frame rigidity, the CT4 has great acceleration capabilities and is subject to less vibration. While the parallel-link robot is installed above the work part and thus normally requires a dedicated base, the CT4 can be installed easily on a plane at the same height as the work part.

Examples of Applications

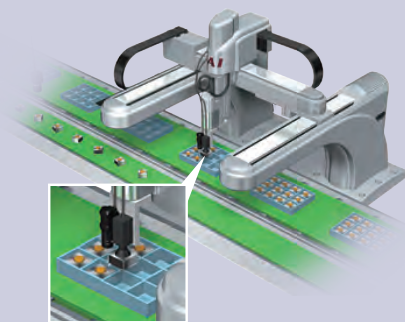

Packing electronic components in boxes

High-speed Cartesian robot
(rotational axis specification) + vision sensor

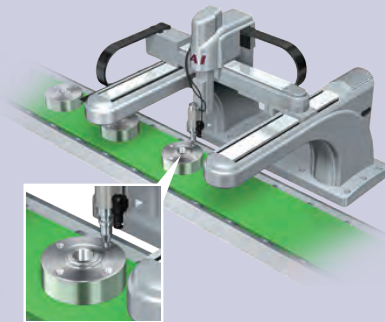

Screwing automobile parts

High-speed Cartesian robot
(standard specification) + vision sensor

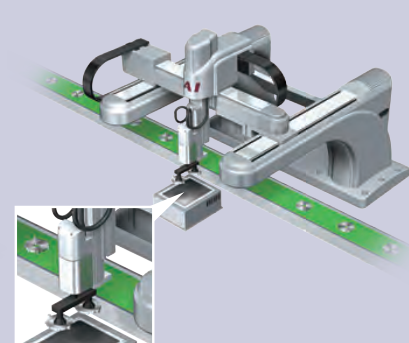

Feeding/taking out work parts to/from
a part inspection machine

High-speed Cartesian robot
(rotational axis specification)

CT4-G1RT-A-40-40-30-10B-36L-T2-□

Orthogonal 4 Axes with Rotational Axis Specification

Model	CT4	G1RT	A	40	40	30	10B	36L	T2	□
Specification Items	Series	Type	Encoder type	X1-axis stroke	X2-axis stroke	Y-axis stroke	Z-axis stroke	Range of operation of R-axis	Applicable controller	Cable length
	CT4: High-speed Cartesian Robot	G1RT: Gantry 4-axis with rotational axis	A: Absolute specification	40 : 400 mm	40 : 400 mm	30 : 300 mm	10B: 100 mm With brake	36L: 360 deg with limit switch	T2: XSEL-PCT XSEL-QCT	3L : 3 m 5L : 5 m □ L : Specified length

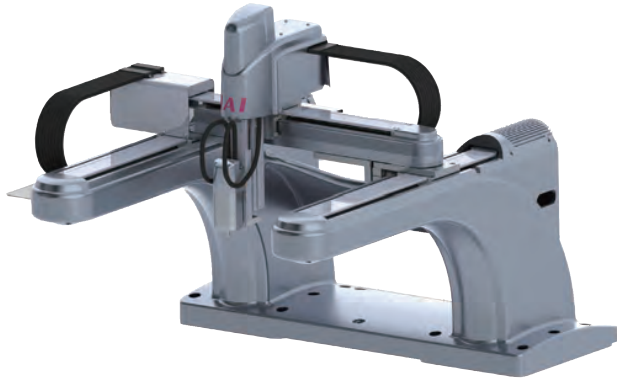

X-axis 400 mm
Y-axis 300 mm
Z-axis 100 mm
R-axis 360°

(Note 1) In the model number, the stroke is indicated in cm (centimeters). The range of operation of the R-axis is indicated in units of 10 degrees.

(Note 2) The cable length indicates the length from the connection point on the actuator's connector to the controller. The standard cable length is 3 m or 5 m, but any other length can be specified in units of meters. Lengths up to 30 m are supported.

Specifications

Model number		CT4-G1RT-A-40-40-30-10B-36L-T2-□				
		X1 (master) axis	X2 (slave) axis	Y-axis	Z-axis	R-axis
Specifications of each axis	Axis type	Slider	Slider	Slider	Table	Rotational axis
	Stroke (mm)	400	400	300	100	360°
	Maximum speed (mm/sec)	2,500	2,500	2,500	833	4500°/s
Combination specifications	Structure	Orthogonal 4 axes (X-axis synchronized operation) + rotational axis				
	Degrees of freedom	4				
	Range of operation X-Y-Z (mm)-R (deg)	400-300-100-360				
	Positioning repeatability (mm)	X direction : ±0.02 (mm), Y direction : ±0.02 (mm), Z direction : ±0.02 (mm), R direction : ±0.025 (deg)				
	Lost motion (mm)	X direction: 0.05 or less, Y direction: 0.05 or less, Z direction: -, R direction: -				
	Payload (kg)	0.5				
	Cycle time [arch motion] Measured value	200st : 0.379 sec, 300st : 0.468 sec				
	(Operating conditions)	Sigmoid control, 2,500 mm/sec, 3.2 G command (4.8 G max. instantaneously). Refer to Fig. A below for the operation pattern.				
	Travel life (km)	X/Y: 20,000, Z: 5,000 (90% probability of survival)				
	R-axis allowable load inertia (kg·m ²)	0.0002				
R-axis allowable moment (N·m)	1.2					
Installation orientation	Limited to horizontal installation					
Ambient temperature/humidity		Temperature: 0 to 40°C, Humidity: 85%RH max. (non-condensing)				

Structure

Item	X1 (master) axis	X2 (slave) axis	Y-axis	Z-axis	R-axis
Motor	AC Servo motor (200 V)				
Home detection	Absolute				
Drive method	Ball screw + coupling				Integrated with motor output shaft
Brake	Not set	Not set	Not set	Standard equipment	Not set
C frame	Aluminum casting				
Robot weight	83.0 kg				

Cycle Time Operation Pattern (Fig. A)

(Note) The standard cycle time represents the time required for going back and forth along the path shown to the right, consisting of a vertical movement of 25 mm, horizontal movement of 200 mm and turning of 180 degrees.

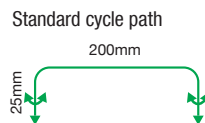

Dynamic Allowable Moment (R-axis)
Allowable moment of rotational axis 1.2 N·m



Direction of dynamic allowable moment

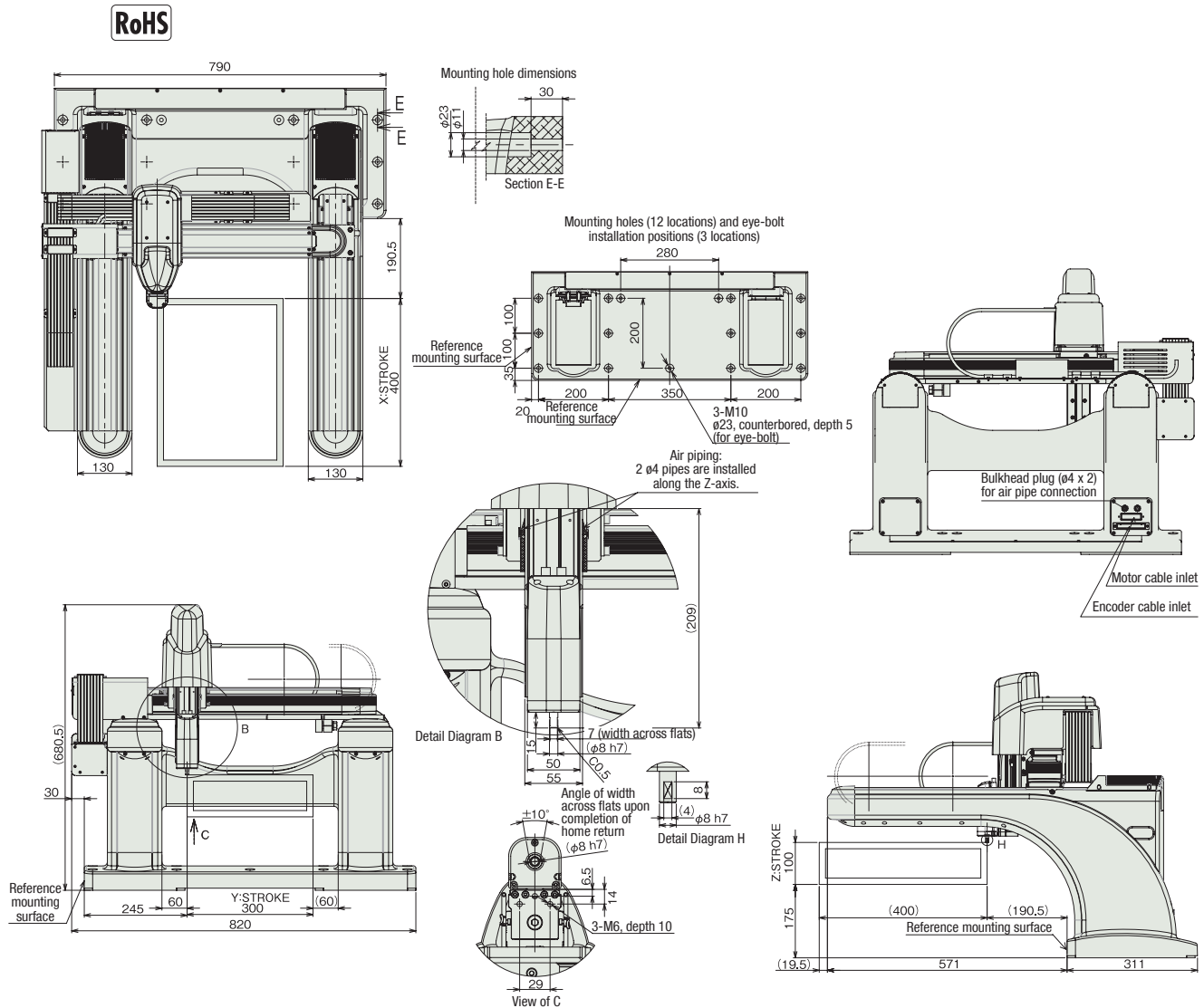

Applicable Controller

Applicable controller	Maximum number of controlled axes	Compatible encoder type	Number of programs	Number of positions	Power-supply voltage	Description
XSEL-PCT	6 axes	Absolute	128 programs	20,000 positions	3-phase, 200VAC	Dedicated standard controller for CT4
XSEL-QCT						Dedicated global controller for CT4 (Safety Category compliant)

[Rough Guide for Work Part Permitted on Rotational Axis]

Use the load inertia calculation formula below to check if the load inertia of the work part is equal to or less than the allowable value (0.0002 kg·m²).

$J = 1/8 \times M \times D^2$

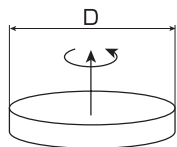

Mass: M

$J = 1/12 \times M \times (a^2 + b^2)$

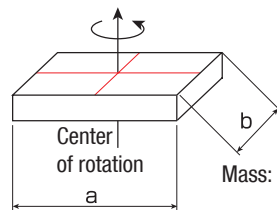

<Example of Permitted Work Part>

If the work part weighs 0.1 kg and is 50 mm wide and 140 mm long, the load inertia is calculated as follows:
 $1/12 \times 0.1 \times (0.14^2 + 0.05^2) \cong 0.00018 \text{ kg}\cdot\text{m}^2$
 Accordingly, this work part is permitted on the rotational axis.

※ Be careful not to let the center of gravity of the work part at the tip of the rotational axis be offset from the output shaft of the rotational axis.



CT4-G1-A-40-40-30-10B-T2-

4-axis Cartesian Specification

Model	CT4	G1	A	40	40	30	10B	T2	<input type="checkbox"/>	<input type="checkbox"/>
Specification	Series	Type	Encoder	X1-axis stroke	X2-axis stroke	Y-axis stroke	Z-axis stroke	Applicable controller	Cable length	Option
Items	CT4 : High-speed Cartesian Robot	G1 : Gantry 4-axis type	A : Absolute specification	40 : 400 mm	40 : 400 mm	30 : 300 mm	10B : 100 mm With brake	T2 : XSEL-PCT XSEL-QCT	3L : 3 m 5L : 5 m <input type="checkbox"/> L : Length designation	Blank: No option AC: Air pipe connection (Vacuum port)



X-axis 400 mm
Y-axis 300 mm
Z-axis 100 mm



(Note 1) Strokes are indicated in cm (centimeters) in the model names.
(Note 2) The cable length is from the connection point on the robot connector to the controller. The standard length is 3 m or 5 m, but other lengths can be specified in m. Lengths up to 30 m are supported.

Specifications

Type		CT4-G1-A-40-40-30-10B-T2- <input type="checkbox"/>			
		X1 (master) axis	X2 (slave) axis	Y-axis	Z-axis
Specifications of each axis	Axis type	Slider	Slider	Slider	Table
	Stroke (mm)	400	400	300	100
	Maximum speed (mm/sec)	2,500	2,500	2,500	833
Combination specifications	Structure	Orthogonal 4-axis (X-axis synchronizing operation)			
	Degrees of freedom	3			
	Operating range X-Y-Z (mm)	400-300-100			
	Positioning repeatability (mm)	X direction : ±0.02, Y direction : ±0.02, Z direction : ±0.02			
	Lost motion (mm)	X direction : 0.05 or less, Y direction : 0.05 or less, Z direction : -			
	Payload (kg)	1			
	Cycle time [arch motion] Measured value	200st : 0.379 sec, 300st : 0.468 sec			
	(Operating conditions)	Sigmoid control, 2,500 mm/sec, commanded acceleration up to 3.2 G (maximum instantaneous acceleration: 4.8 G)			
	Travel life (km)	X/Y : 20,000, Z : 5,000 (90% survival probability)			
	Dynamic allowable moment (Note 1) (N-m)	Ma = 6.4, Mb = 9.2, Mc = 14.2 (based on travel life of 5,000 km)			
Overhang load length (Note 1) (mm)	X direction : 50, Y direction : 50, Z direction : 50				
Installation orientation	Limited to horizontal installation				
Ambient temperature/humidity		Temperature: 0 to 40°C, humidity : 85% RH or less (non-condensing)			

(Note 1) Measured at the mounting point at the end of the Z-axis.

Structure

Item	X1 (master) axis	X2 (slave) axis	Y-axis	Z-axis
Motor	AC servo motor (200V)			
Home detection	Absolute			
Drive system	Ball screw + coupling			
Brake	Not set	Not set	Not set	Standard equipment
C type frame	Aluminum casting			
Robot weight	82.0 kg			

Dynamic allowable moment (Z-axis)

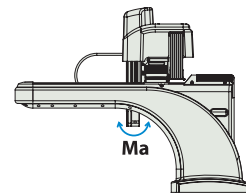
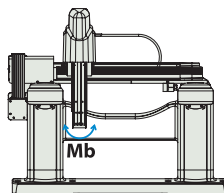
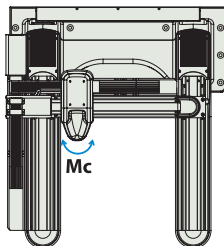

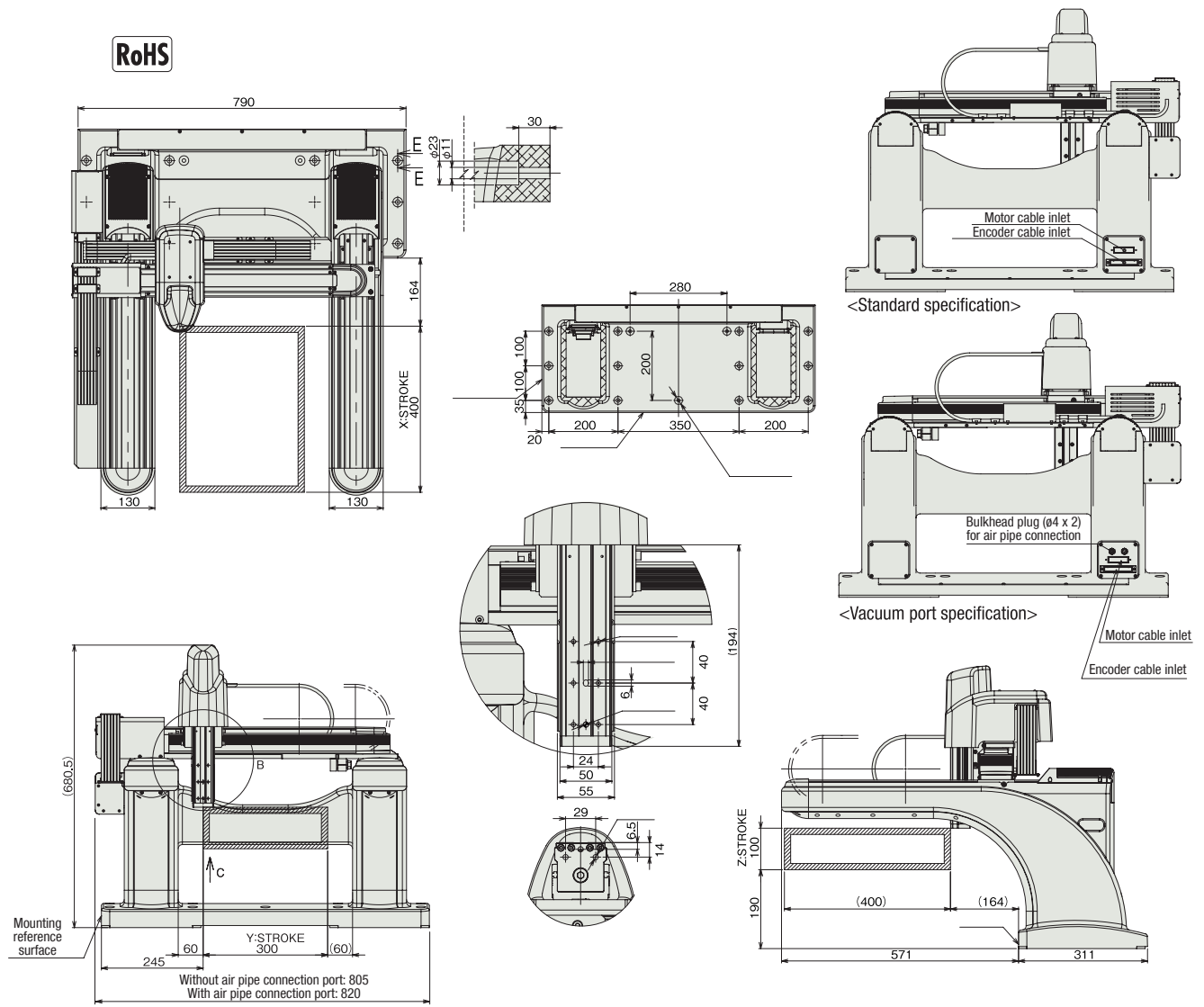

Applicable Controller

Applicable controller	Maximum number of controlled axes	Compatible encoder type	Number of programs	Number of positions	Power-supply voltage	Description
XSEL-PCT	6 axes	Absolute	128 programs	20,000 positions	3-phase, 200VAC	Dedicated standard controller for CT4
XSEL-QCT						Dedicated global controller for CT4 (Safety Category compliant)

[Calculation of Dynamic Allowable Moment]

With the CT4, the dynamic allowable moment is calculated based on a travel life of 20,000 km for the X-axis/Y-axis and travel life of 5,000 km for the Z-axis (both at a survival probability of 90%).

System configuration

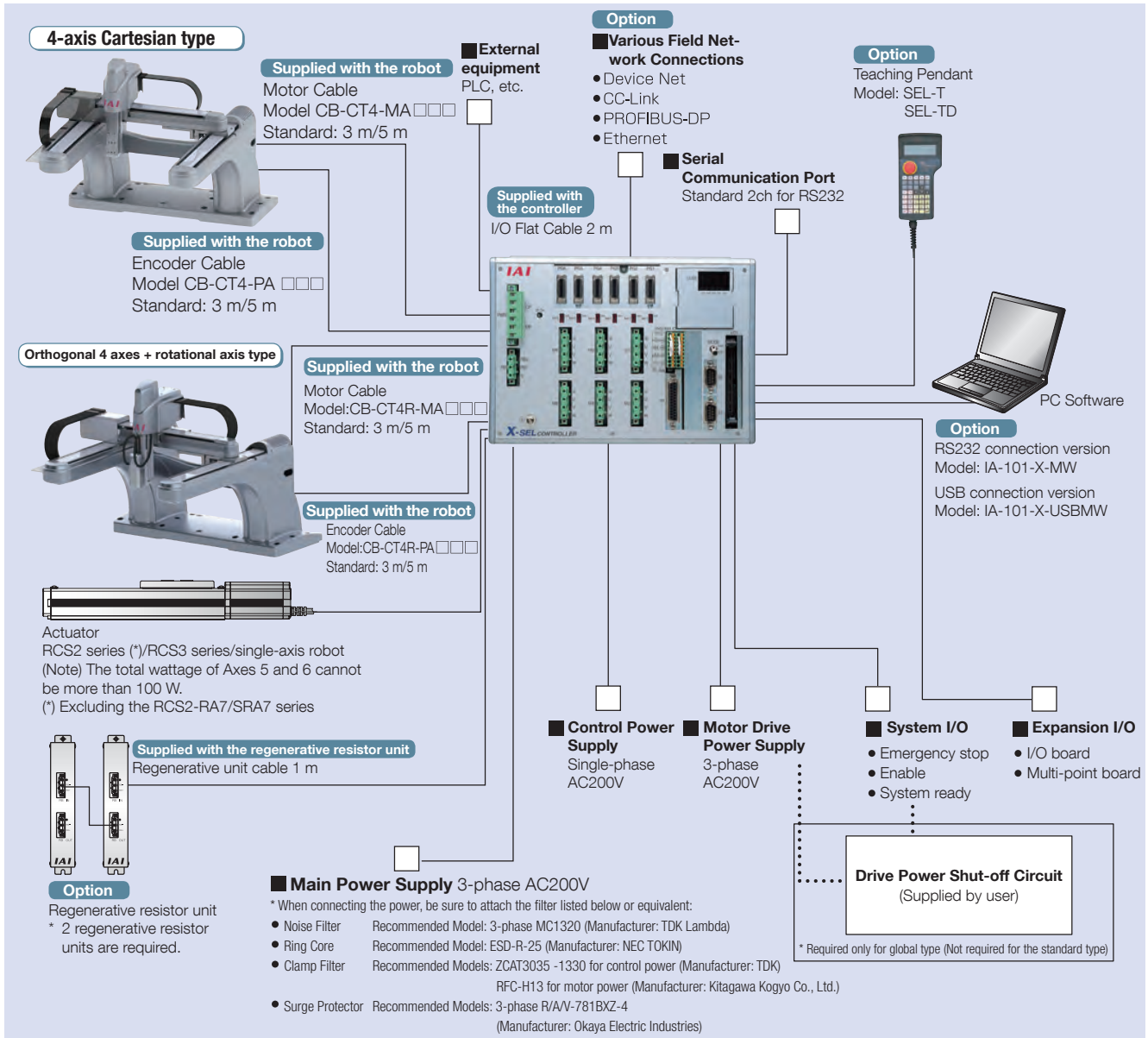

Regenerative Resistance Unit

- Model** REU-1 * Order two regenerative resistor units together with the robot.
- This unit converts to heat the regenerative current produced when the motor decelerates. Two regenerative units are needed to operate the CT4.

Specifications

Item	Specifications
Main Unit dimensions	W34mm x H195mm x D126mm
Main Unit Weight	0.9kg
Built-in regenerative resistor	220Ω 80W
Accessory	Controller Connection Cable (Model No. CB-ST-REU010) 1m

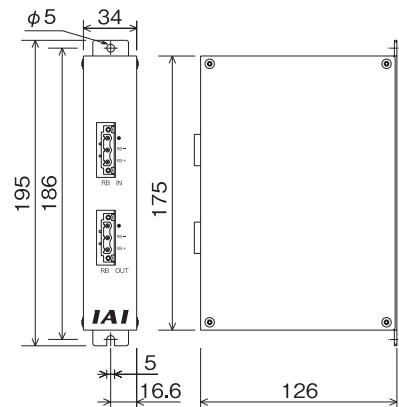

Part Names

<4-axis Cartesian type>

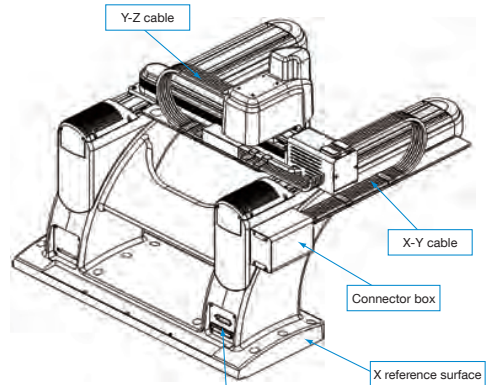
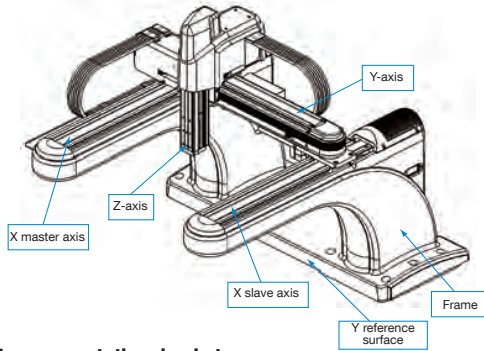

<Orthogonal 4 axes + rotational axis type>

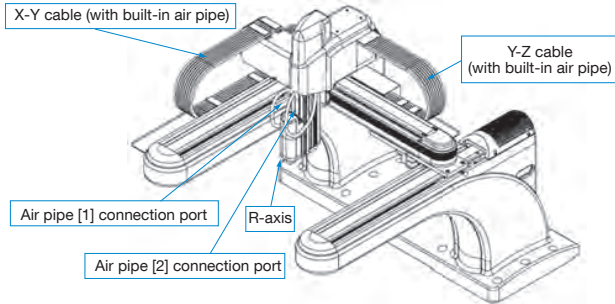

Detail of connector connection point

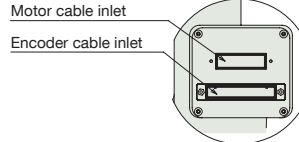

No air pipe specification

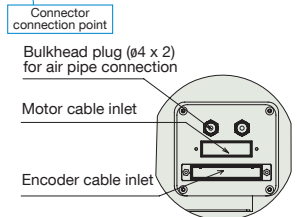

Specification with air pipes

<Air Pipe>
The orthogonal 4 axes + rotational axis type comes standard with an air pipe to the end of the Z-axis.
The orthogonal 4 axes type does not come standard with built-in air pipes, so specify the optional specification with air pipes (option code: AC) if necessary.

Notes

■ Installation Frame

- The mounting surface shall be a machined plane or flat plane of equivalent accuracy. The flatness shall be within 0.05 mm/m.
- The frame shall have a structure that allows the robot to be installed horizontally.
- The frame on which the robot is installed receives a large reactive force. The table below shows the maximum instantaneous reactive force (rough guide) received by each axis when the axis moves at the maximum speed and maximum acceleration carrying 1 kg of load. Provide a frame of sufficient rigidity. Secure the frame to the floor, etc., using anchor bolts, etc., so that the CT4 will not move as a result of robot operation.

Axis	Reactive force
X-axis	660N
Y-axis	235N
Z-axis	85N

- The natural vibration frequency of the frame shall be 75 Hz or more.

■ Example of the Installation Frame

An example of the installation frame is shown to the right. Fabricate the installation frame by referring to this example.

Use the hexagonal head bolt, as described below, for the mounting bolt, depending on the installation frame material.

Use high-strength bolts of ISO-10.9 or more.

<Frame Made of Steel>

Applicable bolt: M10 x 40 (effective engagement length: 10 or more), Applicable washer: M10 (10.5 x 18 x 2)

Tightening torque: 60 N·m

<Frame Made of Aluminum>

Applicable bolt: M10 x 50 (effective engagement length: 20 or more), Applicable washer: M10 (10.5 x 18 x 2)

Tightening torque: 60 N·m

□ 100 x 100mm x t6.0mm
(square steel material)

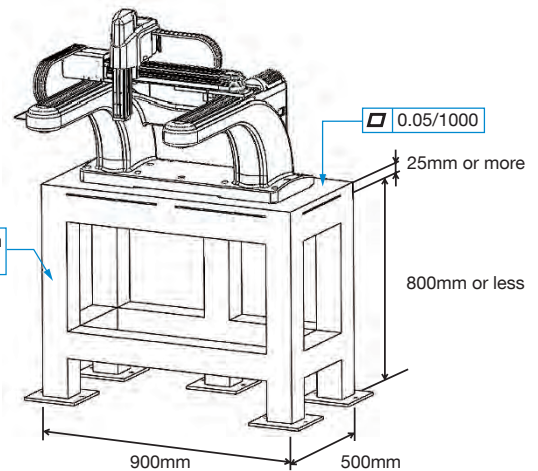

Use the specified type of bolt. Pay attention when selecting the bolt length. If bolts other than the specified type or of inappropriate lengths are used, the tapped holes may be damaged or sufficient mounting strength may not be achieved, potentially leading to noise/vibration, breakdown or shorter life. In the worst case, the CT4 may move suddenly and cause serious accidents such as damage to the work part and surrounding areas, injury or even death.

■ Operation Setting

When operating the high-speed Cartesian robot, the acceleration/deceleration setting for sigmoid motion, and vibration control, must be set in the program. For details, refer to the operation manual.

XSEL-PCT/QCT

Dedicated program controller for CT4 high-speed Cartesian robot



<Orthogonal 4 axes + rotational axis type>

XSEL - [] - [] - 400A - 400A - 400A - 60AB - 60AL - [] - [] - [] - [] - [] - [] - [] - 3

Series Type Number of connected axes Axis 1 Axis 2 Axis 3 Axis 4 Axis 5 Axis 6 Network Standard I/O Expansion I/O I/O Cable Length Power supply voltage

PCT	Dedicated CT4 type		400A	400-watt motor, absolute	400A	400-watt motor, absolute	60AL	60-watt motor, absolute, with limit switch								3	Three-phase 200 VAC
QCT	Dedicated CT4 global type (Safety Category compliant)		400A	400-watt motor, absolute	400A	400-watt motor, absolute	60AB	60-watt motor, absolute, with brake								0	No cable
		5	5-axis specification													2	2m (standard)
		6	6-axis specification													3	3m
																5	5m

* Same as the 5-axis specification if only the CT4 is operating.

Blank	Not used
DV	DeviceNet connection board
CC	CC-Link connection board
PR	Profibus connection board
ET	Ethernet connection board

12I	12-watt motor (incremental)
12A	12-watt motor (absolute)
20I	20-watt motor (incremental)
20A	20-watt motor (absolute)
30DI	RCS 30-watt motor (incremental)
30DA	RCS 30-watt motor (absolute)
30RI	RS 30-watt motor (incremental)
30RA	RS 30-watt motor (absolute)

* The maximum wattage of axis 6 is 30 W. (If the wattage is more than the above, the axis cannot operate due to the limitations of the power-supply capacity.)

E	Not used
N1	Input 32/Output 16 (NPN)
N2	Input 16/Output 32 (NPN)
N3	Input 48/Output 48 (NPN)
P1	Input 32/Output 16 (PNP)
P2	Input 16/Output 32 (PNP)
P3	Input 48/Output 48 (PNP)
S	With expansion I/O base

* If expansion I/O will not be used, enter E (Not used) for slots 2 to 4. If you are using expansion I/Os, enter the expansion I/O base specification code in the desired slot. If an expansion I/O is specified, the controller chassis will come with the expansion I/O base. If you will not be using the expansion I/O initially but will be adding it later, specify the chassis with I/O expansion board, but specify S for slots 2 to 4.

* If "E" (not used) or "S" (with expansion I/O base) is specified for all of standard and expansion I/Os slots, the I/O cable length will become "0" (no cable).

<4-axis Cartesian type>

XSEL - [] - [] - 400A - 400A - 400A - 60AB - [] - [] - [] - [] - [] - [] - [] - 3

Series Type Number of connected axes Axis 1 Axis 2 Axis 3 Axis 4 Axis 5 Axis 6 Network Standard I/O Expansion I/O I/O Cable Length Power supply voltage

PCT	Dedicated CT4 type		400A	400-watt motor, absolute	400A	400-watt motor, absolute											3	Three-phase AC200V
QCT	Dedicated CT4 global type (safety category-compliant specification)		400A	400-watt motor, absolute	400A	400-watt motor, absolute											0	No cable
		4	4-axis specification														2	2m (standard)
		5	5-axis specification														3	3m
		6	6-axis specification														5	5m

Blank	Not used
DV	DeviceNet board
CC	CC-Link board
PR	Profibus board
ET	Ethernet board

12I	12W motor (Incremental)
12A	12W motor (Absolute)
20I	20W motor (Incremental)
20A	20W motor (Absolute)
30DI	30W motor for RCS (Incremental)
30DA	30W motor for RCS (Absolute)
30RI	30W motor for RS (Incremental)
30RA	30W motor for RS (Absolute)
60I	60W motor (Incremental)
60A	60W motor (Absolute)
100I	100W motor (Incremental)
100A	100W motor (Absolute)

* The total wattage of Axes 5 and 6 must not be more than 100 W. (Take note that if the above wattage is exceeded, the robot will not operate due to power-supply capacity limitations.)

E	Not used
N1	Input 32/Output 16 (NPN)
N2	Input 16/Output 32 (NPN)
N3	Input 48/Output 48 (NPN)
P1	Input 32/Output 16 (PNP)
P2	Input 16/Output 32 (PNP)
P3	Input 48/Output 48 (PNP)
S	With expansion I/O base

* If expansion I/O will not be used, enter E (not used) for slots 2 to 4. If you are using expansion I/O, enter the expansion I/O code in the desired slot. If an expansion I/O is specified, the controller chassis will come with the expansion I/O base. If you will not be using the expansion I/O initially but will be adding it later, specify the chassis with I/O expansion board, but specify S for slots 2 to 4.

* If "E" (not used) or "S" (with expansion I/O base) is specified for all of standard and expansion I/O slots, the I/O cable length will become "0" (no cable).

Specifications

Model	Description					
Controller Series, Type	PCT (standard) type			QCT (global) type		
Connecting robots/actuators	CT4, RCS2, RCS3, single-axis robot					
Connectable motor output	CT4 + 100 W max.					
Number of Controlled Axes	4-axis	5-axis	6-axis	4-axis	5-axis	6-axis
Control power-supply input	200/230 AC, single-phase -15%, +10%					
Motor power-supply input	200/230 AC, three-phase -10%, +10%					
Power Supply Frequency	50/60Hz					
Insulation resistance	10 MΩ or more (between power-supply terminal and I/O terminal, or between all external terminals and case, at DC500V)					
Withstand voltage	AC1500V (1 minute)					
Power Supply Capacity (*1)	Max 4019VA	Max 4265VA	Max 4271VA	Max 4019VA	Max 4265VA	Max 4271VA
Position detection method	Incremental Encoder (serial encoder) Absolute encoder with a rotational data backup (serial encoder)					
Safety Circuit Configuration	Redundancy not supported			Redundancy supported		
Drive Source Breaker System	Cutoff by internal relay			External safety circuit		
Enable Input	Contact B input (internally powered)			Contact B input (externally powered, redundant)		
Speed setting	1 mm/sec or greater. The upper limit varies according to the actuator specification.					
Acceleration/Deceleration Setting	0.01 G or greater. The upper limit varies according to the actuator.					
Program language	Super SEL language					
Number of programs	128 Programs					
Number of program steps	9,999 Steps (total)					
Number of multi-tasking programs	16 Programs					
Number of Positions	20,000 Steps (total)					
Data memory device	Flash ROM + SRAM Battery Backup					
Data input method	Teaching pendant or PC software					
Standard Input/Output	48-I/O PIO board (NPN/PNP) or 96-I/O PIO board (NPN/PNP). Only 1 board can be installed.					
Expansion Input/Output	48-I/O PIO board (NPN/PNP) and/or 96-I/O PIO board (NPN/PNP). Up to 3 boards can be installed.					
Serial communication function	Teaching pendant port (D-sub 25-pin) + 2-channel RS232C port (D-sub, 9-pin x 2). Standard equipment.					
Protective function	Motor overcurrent, Overload, Motor driver temperature check, Overload check, Encoder open-circuit check, soft limit over, system error, battery error					
Ambient Operating Temperature / Humidity and Atmosphere	0 to 40°C, 10 to 95% (non-condensing). Free from corrosive gases. In particular, there shall be no significant dust.					
Robot weight (*2)	5.2kg		5.7kg		4.5kg	5kg
Accessory	I/O Flat Cable					

*1 When the connected axes represent the maximum wattage.

*2 Including the absolute-data backup battery, brake mechanism and expansion I/O box.

XSEL-PCT/QCT Controller

I/O Signal table

Standard I/O Signal Table (when N1 or P1 is selected)

Pin No.	Classification	Port No.	Standard Settings
1		-	(J/P/Q type: 24V connection / K type: NC)
2		000	Program start
3		001	General Purpose Input
4		002	General Purpose Input
5		003	General Purpose Input
6		004	General Purpose Input
7		005	General Purpose Input
8		006	General Purpose Input
9		007	Program Specification (PRG No.1)
10		008	Program Specification (PRG No.2)
11		009	Program Specification (PRG No.4)
12		010	Program Specification (PRG No.8)
13		011	Program Specification (PRG No.10)
14		012	Program Specification (PRG No.20)
15		013	Program Specification (PRG No.40)
16	Input	014	General Purpose Input
17		015	General Purpose Input
18		016	General Purpose Input
19		017	General Purpose Input
20		018	General Purpose Input
21		019	General Purpose Input
22		020	General Purpose Input
23		021	General Purpose Input
24		022	General Purpose Input
25		023	General Purpose Input
26		024	General Purpose Input
27		025	General Purpose Input
28		026	General Purpose Input
29		027	General Purpose Input
30		028	General Purpose Input
31		029	General Purpose Input
32		030	General Purpose Input
33	031	General Purpose Input	
34	Output	300	Alarm Output
35		301	Ready Output
36		302	Emergency Stop Output
37		303	General Purpose Output
38		304	General Purpose Output
39		305	General Purpose Output
40		306	General Purpose Output
41		307	General Purpose Output
42		308	General Purpose Output
43		309	General Purpose Output
44		310	General Purpose Output
45		311	General Purpose Output
46		312	General Purpose Output
47		313	General Purpose Output
48		314	General Purpose Output
49		315	General Purpose Output
50			-

Extension I/O Signal Table (when N1 or P1 is selected)

Pin No.	Classification	Standard Settings
1		(J/P/Q type: 24V connection / K type: NC)
2		General Purpose Input
3		General Purpose Input
4		General Purpose Input
5		General Purpose Input
6		General Purpose Input
7		General Purpose Input
8		General Purpose Input
9		General Purpose Input
10		General Purpose Input
11		General Purpose Input
12		General Purpose Input
13		General Purpose Input
14		General Purpose Input
15		General Purpose Input
16		General Purpose Input
17	Input	General Purpose Input
18		General Purpose Input
19		General Purpose Input
20		General Purpose Input
21		General Purpose Input
22		General Purpose Input
23		General Purpose Input
24		General Purpose Input
25		General Purpose Input
26		General Purpose Input
27		General Purpose Input
28		General Purpose Input
29		General Purpose Input
30		General Purpose Input
31		General Purpose Input
32		General Purpose Input
33		General Purpose Input
34	Output	General Purpose Output
35		General Purpose Output
36		General Purpose Output
37		General Purpose Output
38		General Purpose Output
39		General Purpose Output
40		General Purpose Output
41		General Purpose Output
42		General Purpose Output
43		General Purpose Output
44		General Purpose Output
45		General Purpose Output
46		General Purpose Output
47		General Purpose Output
48		General Purpose Output
49		General Purpose Output
50		

Extension I/O Signal Table (when N2 or P2 is selected)

Pin No.	Classification	Standard Settings
1		(J/P/Q type: 24V connection / K type: NC)
2		General Purpose Input
3		General Purpose Input
4		General Purpose Input
5		General Purpose Input
6		General Purpose Input
7		General Purpose Input
8		General Purpose Input
9	Input	General Purpose Input
10		General Purpose Input
11		General Purpose Input
12		General Purpose Input
13		General Purpose Input
14		General Purpose Input
15		General Purpose Input
16		General Purpose Input
17		General Purpose Input
18		General Purpose Output
19		General Purpose Output
20		General Purpose Output
21		General Purpose Output
22		General Purpose Output
23		General Purpose Output
24		General Purpose Output
25		General Purpose Output
26	General Purpose Output	
27	General Purpose Output	
28	General Purpose Output	
29	General Purpose Output	
30	General Purpose Output	
31	General Purpose Output	
32	General Purpose Output	
33	General Purpose Output	
34	Output	General Purpose Output
35		General Purpose Output
36		General Purpose Output
37		General Purpose Output
38		General Purpose Output
39		General Purpose Output
40		General Purpose Output
41		General Purpose Output
42		General Purpose Output
43		General Purpose Output
44		General Purpose Output
45		General Purpose Output
46		General Purpose Output
47		General Purpose Output
48		General Purpose Output
49		General Purpose Output
50		

External Dimensions

Controller Type	Encoder Brake I/O	Standard specification	With expansion I/O base	Side View Common
		Absolute	Absolute	
		Yes	Yes	
PCT	4 axis Specification			
	5 to 6 axis Specification			
QCT	4 axis Specification			
	5 to 6 axis Specification			

Option

Teaching Pendant

A teaching device that has program/position input, test operation, monitoring function, etc.

Model

Model	Description
SEL-T	Standard type
SEL-TD	With deadman switch

Configuration

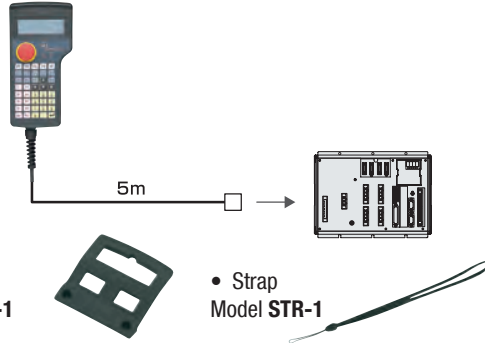

SEL-T Option

- Wall-mounting hook Model **HK-1**

- Strap Model **STR-1**

SEL-T
SEL-TD

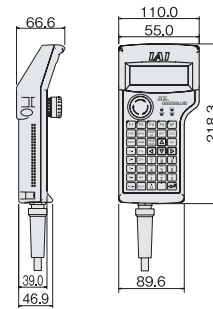

Specifications

Item	SEL-T	SEL-TD
3-position enable switch	Not available	Available
ANSI/UL standard	Not supported	Supported
CE mark	Supported	
Display	20 characters x 4 lines	
Ambient operating temperature/humidity	0 to 40°C 10 to 90% RH (non-condensing)	
Protective structure	IP54	
Mass	Approx. 0.4 kg (cable excluded)	

PC software (Windows dedicated)

- Features
- A startup support software program offering program/position input function, test operation function, monitoring function, and more.
 - The functions needed for debugging have been enhanced to help reduce the startup time.

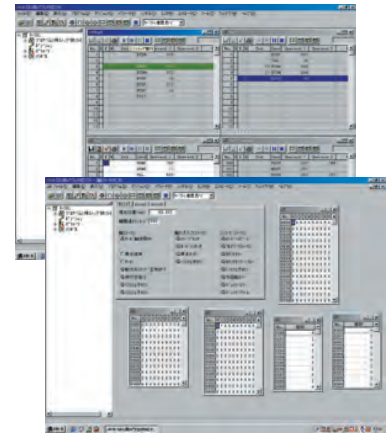

<XSEL-P/PX/PCT Type>

Model **IA-101-X-MW** (with RS232C cable)

Configuration

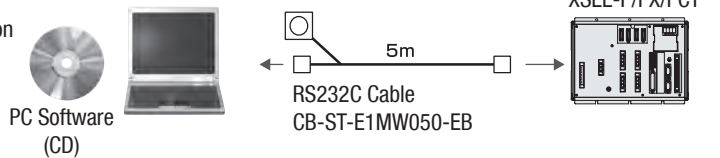

Model **IA-101-X-USBMW** (with USB Conversion Adapter + Cable)

Configuration

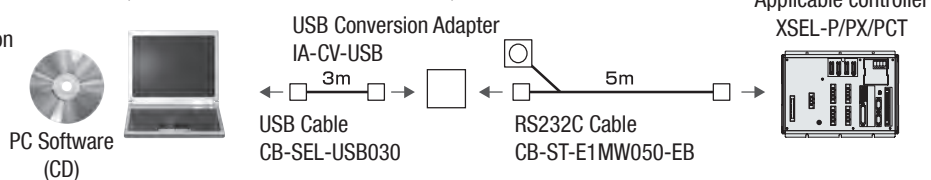

<XSEL-Q/QX/QCT Type>

Model **IA-101-XA-MW** (with safety category 4-compliant cable)

Configuration

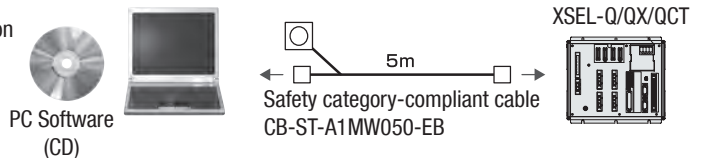

Note

Use the IA-101-X-MW or IA-101-X-USBMW for the XSEL-P/PX/PCT.
Use the IA-101-XA-MW for the XSEL-Q/QX/QCT.
Note that connecting a PC software cable to a controller not supporting the cable may damage the internal parts of the controller.

XSEL-PCT/QCT Controller

Service Parts

Motor Cable <Orthogonal 4 axes + rotational axis type>

Model: **CB-CT4R-MA**

[Minimum bending radius]

Flexible cable: 51 mm

Fixed cable: 34 mm

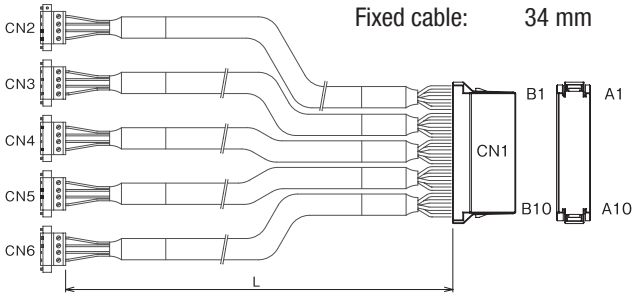

Enter the cable length (L) into (Maximum 30m). Ex.: 080 = 8m

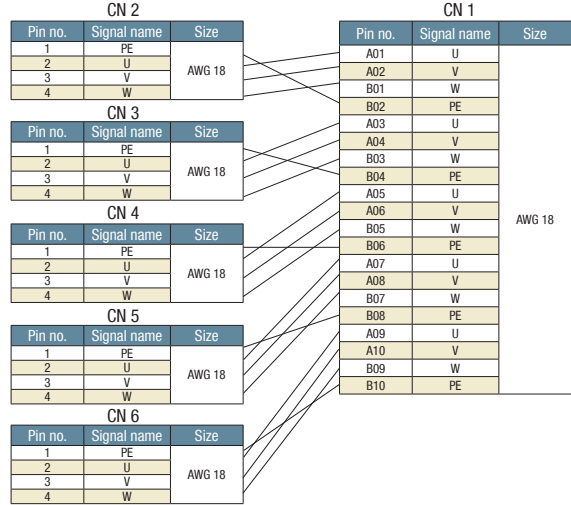

Encoder Cable <Orthogonal 4 axes + rotational axis type>

Model: **CB-CT4R-PA**

[Minimum bending radius]

Flexible cable: 44 mm

Fixed cable: 29 mm

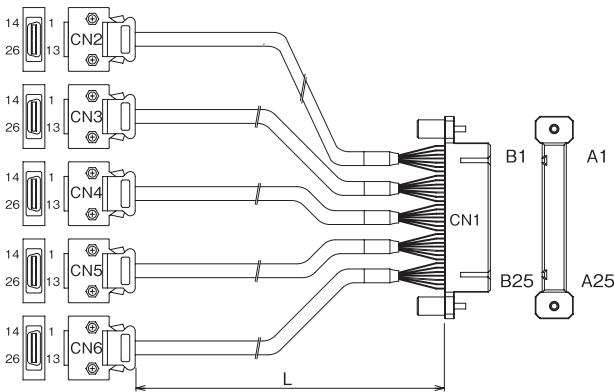

Enter the cable length (L) into (Maximum 30m). Ex.: 080 = 8m

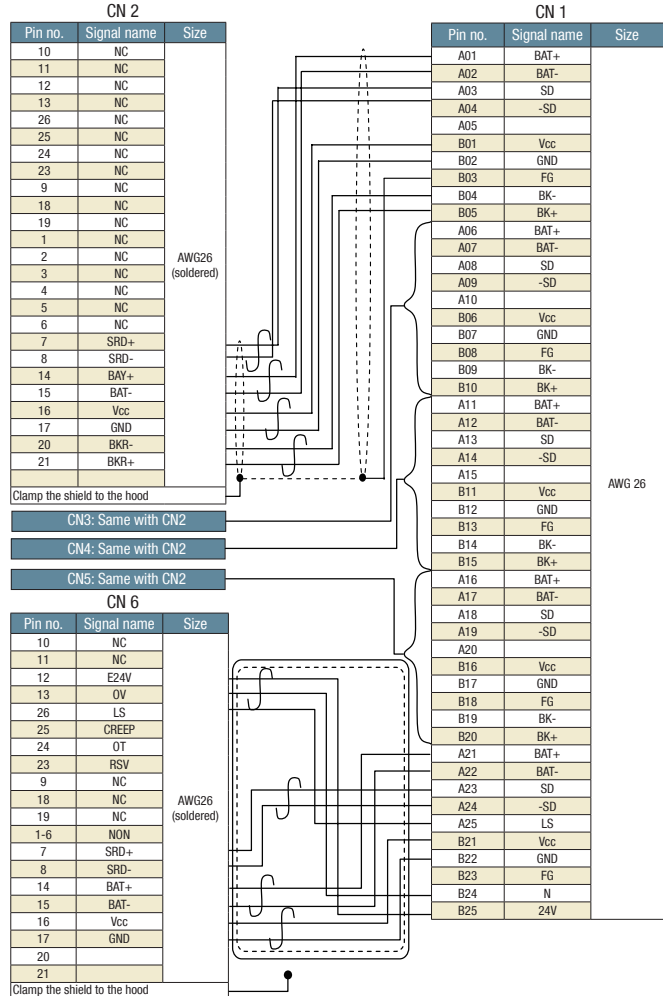

Motor cable < 4-axis Cartesian type >

Model **CB-CT4-MA**

[Minimum Bend Radius]
Movable: 51 mm
Fixed: 34 mm

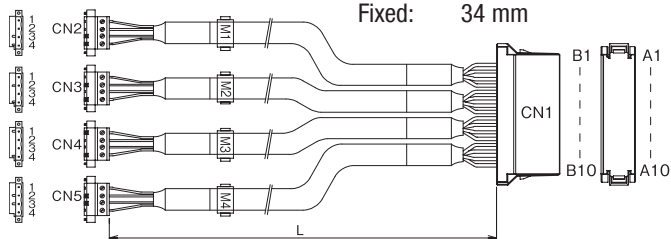

Enter the cable length (L) into (Maximum 30m). Ex.: 080 = 8m

CN 2			CN 1		
Pin no.	Signal name	Size	Pin no.	Signal name	Size
1	PE	AWG 18	A01	U	AWG 18
2	U		A02	V	
3	V		B01	W	
4	W		B02	PE	
CN 3			A03	U	
1	PE	AWG 18	A04	V	
2	U		B03	W	
3	V		B04	PE	
4	W		A05	U	
CN 4			A06	V	
1	PE	AWG 18	B05	W	
2	U		B06	PE	
3	V		A07	U	
4	W		A08	V	
CN 5			B07	W	
1	PE	AWG 18	B08	PE	
2	U		A09	NC	
3	V		A10	NC	
4	W		B09	NC	
			B10	NC	

Encoder cable < 4-axis Cartesian type >

Model **CB-CT4-PA**

[Minimum Bend Radius]
Movable: 44 mm
Fixed: 29 mm

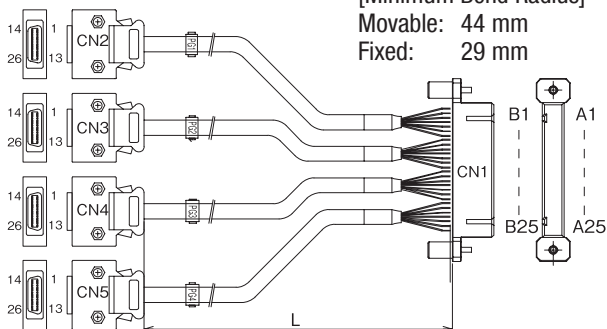

Enter the cable length (L) into (Maximum 30m). Ex.: 080 = 8m

CN 2			CN 1		
Pin no.	Signal name	Size	Pin no.	Signal name	Size
10	NC	AWG18 (soldered)	A01	BAT+	AWG 26
11	NC		A02	BAT-	
12	NC		A03	SD	
13	NC		A04	-SD	
26	NC		A05		
25	NC		B01	Vcc	
24	NC		B02	GND	
23	NC		B03	FG	
9	NC		B04	BK-	
18	NC		B05	BK+	
19	NC		A06	BAT+	
1	NC		A07	BAT-	
2	NC		A08	SD	
3	NC		A09	-SD	
4	NC		A10		
5	NC		B06	Vcc	
6	NC		B07	GND	
7	SRD+		B08	FG	
8	SRD-		B09	BK-	
14	BAY+		B10	BK+	
15	BAT-		A11	BAT+	
16	Vcc	A12	BAT-		
17	GND	A13	SD		
20	BJR+	A14	-SD		
21	BKR-	A15			
		B11	Vcc		
		B12	GND		
		B13	FG		
		B14	BK-		
		B15	BK+		
		A16	BAT+		
		A17	BAT-		
		A18	SD		
		A19	-SD		
		A20			
		B16	Vcc		
		B17	GND		
		B18	FG		
		B19	BK-		
		B20	BK+		
		A21			
		A22			
		A23			
		A24			
		A25			
		B21			
		B22			
		B23			
		B24			
		B25			

The shield is connected to the hood by a clamp.

CN3: Same with CN2
CN4: Same with CN2
CN5: Same with CN2

I/O flat cable (for XSEL-J/K/P/Q)

Model **CB-X-PIO**

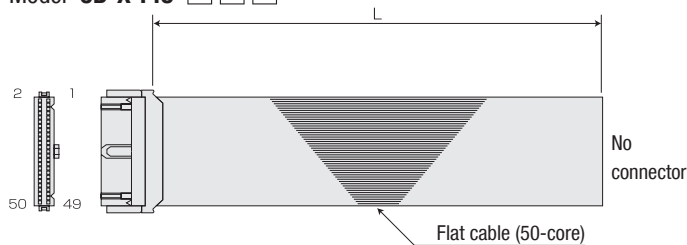

Enter the cable length (L) into (Maximum 10m). Ex.: 080 = 8m

Number	Color	Wire	Number	Color	Wire	Number	Color	Wire
1	Brown 1	Flat cable crimped	18	Gray 2	Flat cable crimped	35	Green 4	Flat cable crimped
2	Red 1		19	White 2		36	Blue 4	
3	Orange 1		20	Black 2		37	Purple 4	
4	Yellow 1		21	Brown-3		38	Gray 4	
5	Green 1		22	Red 3		39	White 4	
6	Blue 1		23	Orange 3		40	Black 4	
7	Purple 1		24	Yellow 3		41	Brown-5	
8	Gray 1		25	Green 3		42	Red 5	
9	White 1		26	Blue 3		43	Orange 5	
10	Black 1		27	Purple 3		44	Yellow 5	
11	Brown-2		28	Gray 3		45	Green 5	
12	Red 2		29	White 3		46	Blue 5	
13	Orange 2		30	Black 3		47	Purple 5	
14	Yellow 2		31	Brown-4		48	Gray 5	
15	Green 2		32	Red 4		49	White 5	
16	Blue 2		33	Orange 4		50	Black 5	
17	Purple 2		34	Yellow 4				