

Thrust-Speed Curve

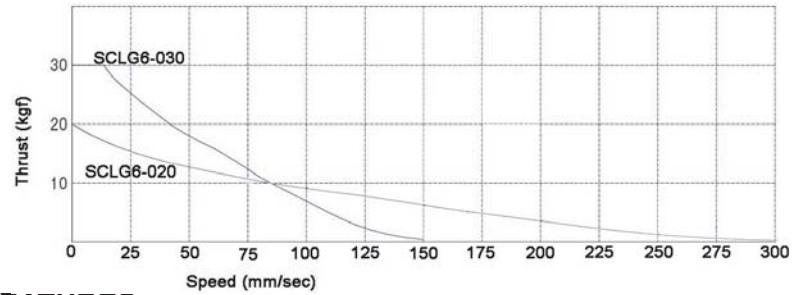

FEATURES

Unit includes:

- closed loop servo motor, external servo amplifier and control
- linear actuation mechanism with Aluminum extrusion housing
- Re-circulating ball type linear guide rail for heavier load
- positioning table and slider mounting slots with nuts
- exact replacement for SCLL6
- positioning table and slider mounting slots with nuts

Specifications

MODEL	SCLG6-020- XXX -AB							SCLG6-030- XXX -AB													
	300	400	500	600	700	800	1000	300	400	500	600	700	800	1000							
Stroke (mm)	300	400	500	600	700	800	1000	300	400	500	600	700	800	1000							
Max. Thrust (N)/(kgf)	200 / 20.4							300 / 30.6													
Push mode max. Thrust (N)/(kgf)	140 / 14.2							280 / 28.6													
Max. Speed (mm/s) * Typ. Data	300			280				220		150			150		140			110		75	
Max. Load weight (kgf)	20							20													
Max. vertical load (kgf)	10							20													
Load moment (N-m / kg-fcm)	Mp= 6 / 60, My= 6/60, Mr= 10 /100																				
Max. axial thrust at power ON (N)	25																				
Overhang length (mm)	150 or shorter																				
Actuator weight (kg)	3.7	4.7	5.7	6.7	7.7	8.7	10.7	3.7	4.7	5.7	6.7	7.7	8.7	10.7							
Servo amplifier weight (kg)	0.5																				

Dimensions

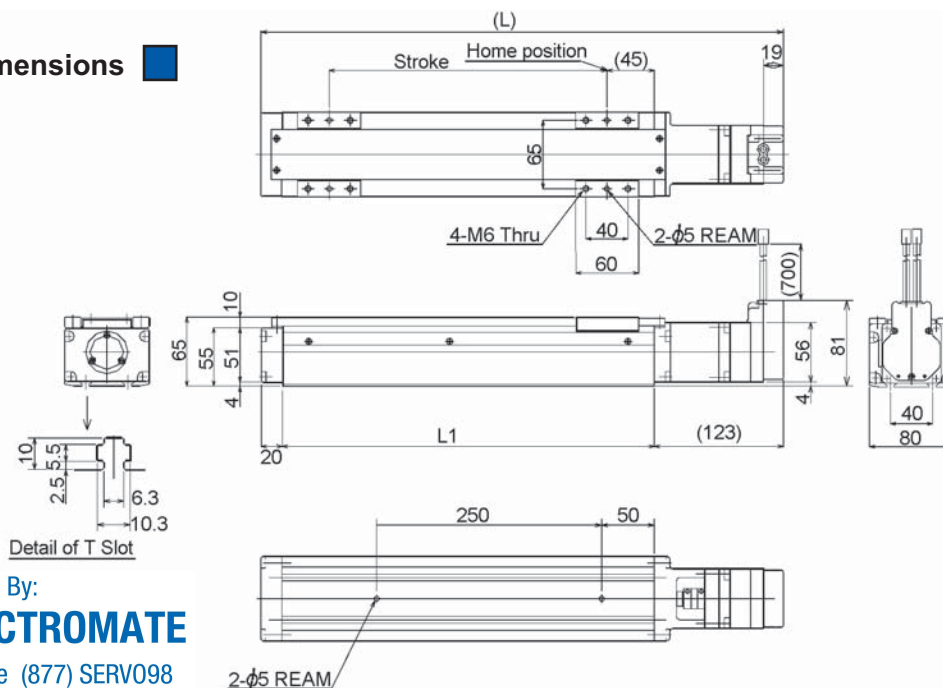

Quantity of M6 nut included for T slot:

Strokes	Quantity
200mm ~ 300mm	4 pcs
400mm ~ 700mm	6 pcs
800mm	8 pcs
900mm ~ 1000mm	10 pcs

MODEL	Stroke	L	L1
SCLG6-020/030-200	200	433	290
SCLG6-020/030-300	300	533	390
SCLG6-020/030-400	400	633	490
SCLG6-020/030-500	500	733	590
SCLG6-020/030-600	600	833	690
SCLG6-020/030-700	700	933	790
SCLG6-020/030-800	800	1033	890
SCLG6-020/030-900	900	1133	990
SCLG6-020/030-A00	1,000	1233	1090

(Unit in mm)

Sold & Serviced By:



Toll Free Phone (877) SERV098
www.electromate.com
sales@electromate.com