

Encoder Guide



Sold & Serviced By:

 **ELECTROMATE**

Toll Free Phone (877) SERV098

Toll Free Fax (877) SERV099

www.electromate.com

sales@electromate.com



ITT

ENGINEERED FOR LIFE

ENCODER GUIDE - ROTARY INCREMENTAL

At Torque Systems, we offer a wide selection of Rotary Incremental Encoders, providing you numerous solutions for a wide range of position and control application requirements.

The following encoder list includes our most current DataTorque™ Encoder Family. Each encoder display provides a brief capsule of capabilities as well as package dimensions.

DataTorque™ SM7



- SM7 Hollow Shaft
- Resolution to 2048CPR
- Input Voltage 5 to 26VDC
- Output A, B & Z
- Option of Line Driver
- Frequency 200KHz
- Miniature precision

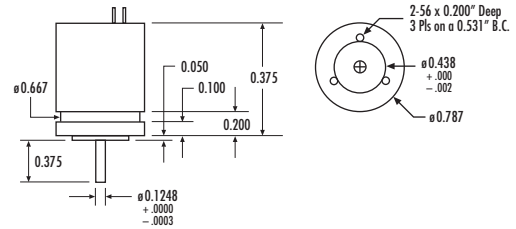

DataTorque™ HS15



- HS15 Hollow Shaft
- Resolution to 5000CPR
- Input Voltage 5 to 26VDC
- Output A, B & Z
- Option of Line Driver
- Frequency 500KHz
- Bore 0.25 in. to 10 mm
- Modular alternative

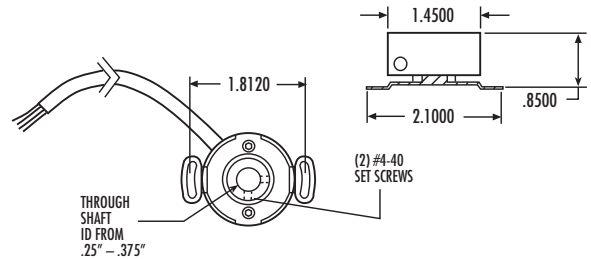

DataTorque™ SM15



- SM15 Shaft Encoder
- Resolution to 2500CPR
- Input Voltage 5 to 24VDC
- Output A, B & Z
- Option of Line Driver
- Frequency 200KHz
- CE Compliant
- Light Industrial

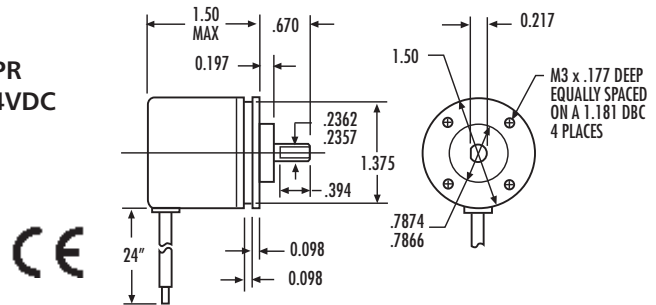

DataTorque™ SM16



- SM16 Shaft Encoder
- Resolution to 2500CPR
- Input Voltage 5 to 24VDC
- Output A, B & Z
- Option of Line Driver
- Frequency 200KHz
- Shaft loading 10 lbs.
- CE Compliant
- IP65 Rating

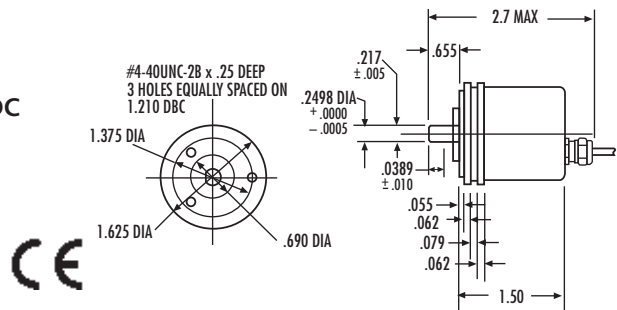

Sold & Serviced By:



Toll Free Phone (877) SERV098
 Toll Free Fax (877) SERV099
www.electromate.com
sales@electromate.com



ENCODER GUIDE - ROTARY INCREMENTAL

The DataTorque™ Encoder Guide will help you in your selection process by providing a general comparison. Please use it for reference only.

Be sure to consult with one of our Sales & Applications Specialists prior to selecting the exact DataTorque™ Encoder to match your specific application requirements.

DataTorque™ SM23



- SM23 Shaft Encoder
- Resolution to 2500CPR
- Input Voltage 5, 12 & 15VDC
- Output A, B & Z
- Option of Line Driver
- Frequency 200KHz
- Shaft Loading 10 lbs.
- Multi-purpose

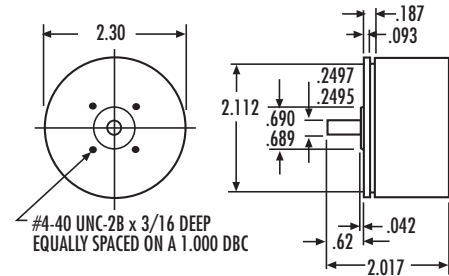

DataTorque™ RS23



- RS23 Shaft Encoder
- Resolution to 2500 CPR
- Input Voltage 5, 12 & 15VDC
- Output A, B & Z
- Option of Line Driver
- Frequency 200KHz
- CE Compliant
- Instrument Grade

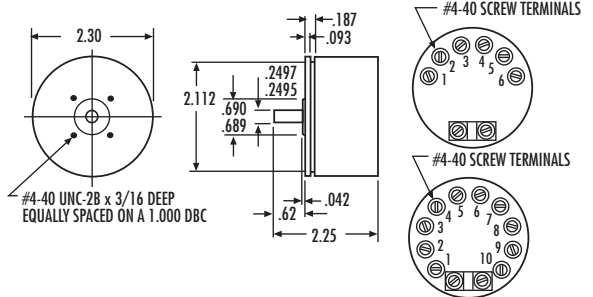

DataTorque™ DT20



- DT20 Shaft Encoder
- Resolution to 2500CPR
- Input Voltage 5 to 24VDC
- Output A, B & Z
- Option of Line Driver
- Frequency 200KHz
- Shaft Loading to 80 lbs.
- IP65 Rating
- CE Compliant
- Heavy Industrial

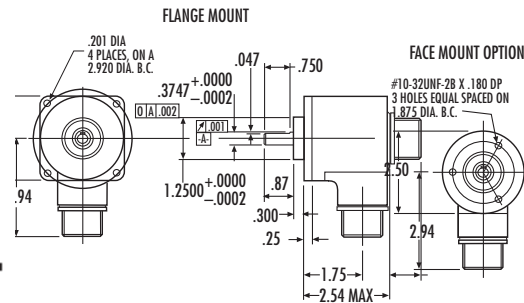

Sold & Serviced By:

 **ELECTROMATE**

Toll Free Phone (877) SERV098

Toll Free Fax (877) SERV099

www.electromate.com

sales@electromate.com



ENCODER GUIDE - ROTARY INCREMENTAL



- DT25 Shaft Encoder
- Resolution to 5400CPR
- Input Voltage 5, 12 & 15VDC
- Output A, B & Z
- Option of Line Driver
- Frequency 200KHz
- Servo or Face Mounting
- CE Compliant
- Heavy Industrial

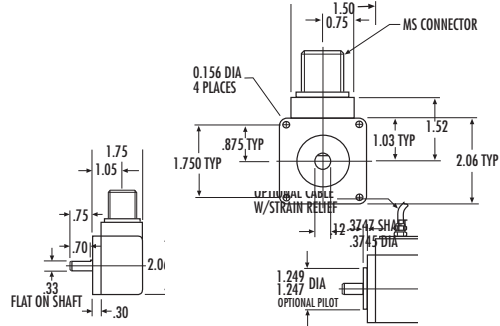

- OC25 or OS25 Shaft Encoder
- Resolution to 5400CPR
- Input Voltage 5, 12 & 15VDC
- Output A, B & Z
- Option of Line Driver
- Frequency 200KHz
- Servo or Face Mounting
- Industrial

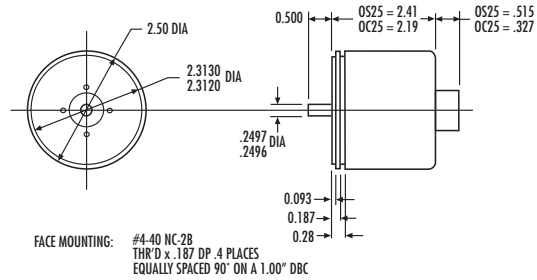

- ON25 Shaft Encoder
- Resolution to 5400CPR
- Input Voltage 5, 12 & 15VDC
- Output A, B & Z
- Option of Line Driver
- Frequency 200KHz
- Servo or Face Mounting
- Heavy Industrial

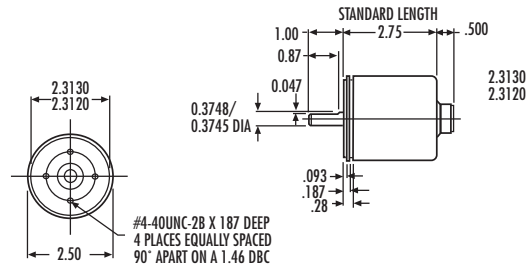

Sold & Serviced By:



Toll Free Phone (877) SERV098

Toll Free Fax (877) SERV099

www.electromate.com

sales@electromate.com