

RSA/RSM & GSA/GSM ELECTRIC ROD-STYLE ACTUATORS

 **ENDURANCE TECHNOLOGY**™



Sold & Serviced By:

 **ELECTROMATE**

Toll Free Phone (877) SERV098
Toll Free Fax (877) SERV099
www.electromate.com
sales@electromate.com



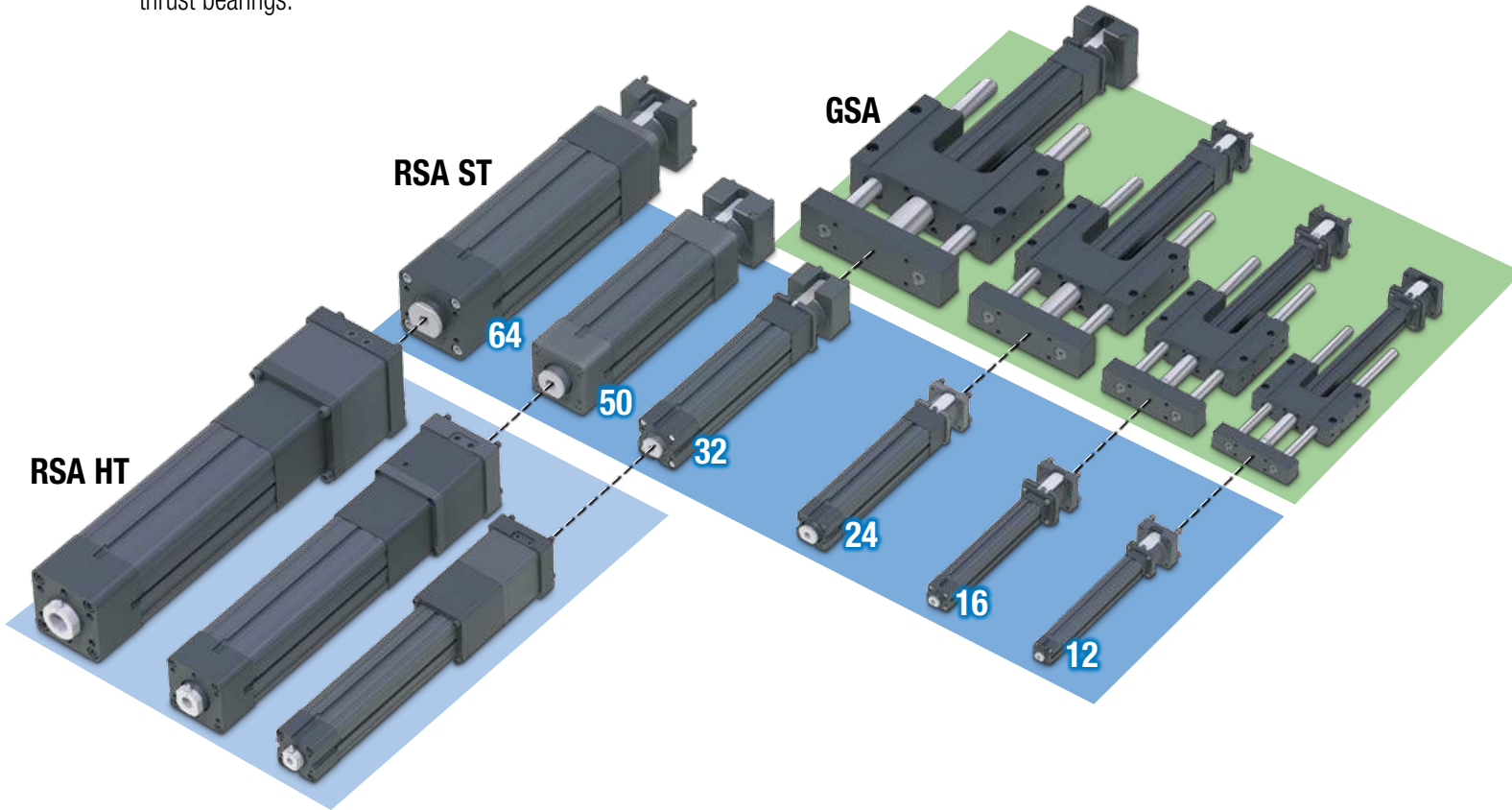

RSA & GSA Electric Rod-Style Actuator

WHAT ARE THE RSA & THE GSA?

The RSA is a flexible electric screw driven rod-style actuator. The standard (ST) model comes in six sizes. The guided RSA (GSA) adds guidance and load support to the design and is available in the 4 smaller sizes. The high force (HT) model is available in the 3 larger sizes, it incorporates stronger torque transmission components (couplers, pulleys, belts) and higher thrust bearings.



TOLOMATIC'S ELECTRIC ROD-STYLE ACTUATORS

| | ERD | ICR | RSA | GSA | IMA |
|-----------------------------|---|---|--|---|---|
| |  |  |  |  |  |
| | Rod-Style Actuator | Integrated Control Rod-Style Actuator | Rod-Style Actuator | Guided Rod-Style Actuator | Integrated Motor Rod-Style Actuator |
| Thrust up to: | 4,500 lbf [20,017 N] | 720 lbf [3,202.7 N] | 13,039 lbf [58,001 N] | 950 lbf [4,226 N] | 6,875 lbf [30,594 N] |
| Speed up to: | 58 in/sec [1473 mm/sec] | 25 in/sec [635 mm/sec] | 123 in/sec [3,124 mm/sec] | 123 in/sec [3,124 mm/sec] | 52.5 in/sec [1,334 mm/sec] |
| Stroke Length up to: | 39.4 in [1000 mm] | 24 in [609 mm] | 60 in [1,524 mm] | 36 in [914 mm] | 18 in [457 mm] |
| Screw/Nut Type | Solid, Ball & Roller | Ball | Solid, Ball & Roller | Solid & Ball | Ball & Roller |
| | <i>For complete information see</i> | | | <i>or literature number:</i> | |
| | 2190-4000 | 2100-4000 | 3600-4609 | 3600-4609 | 2700-4000 |

(Not all models deliver maximum values listed, i.e.: Maximum thrust may not be available with maximum speed)

Sold & Serviced By:



Toll Free Phone (877) SERV098

Toll Free Fax (877) SERV009

www.electromate.com

sales@electromate.com

Literature Number:

RSA & GSA Electric Rod-Style Actuator

Applications

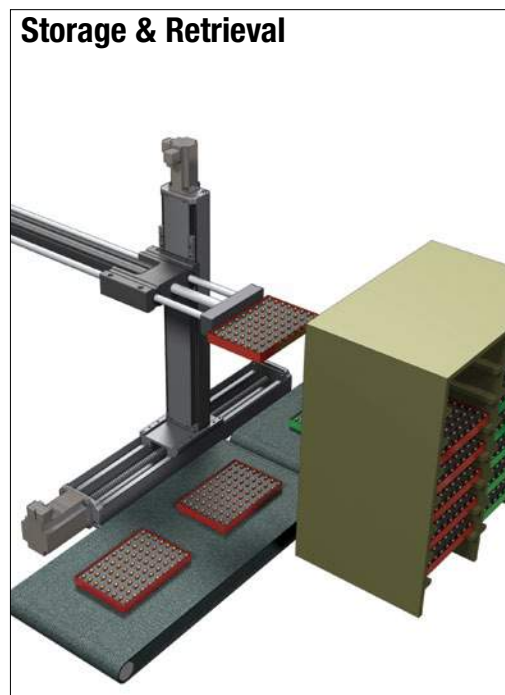
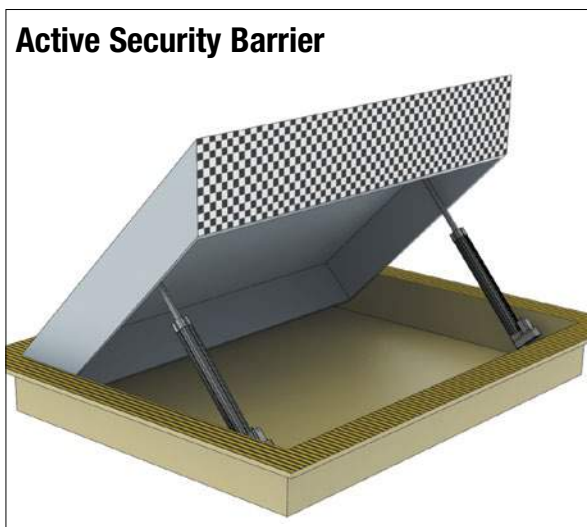
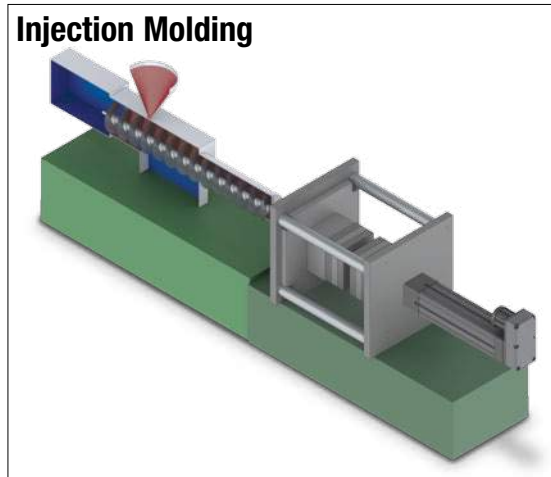
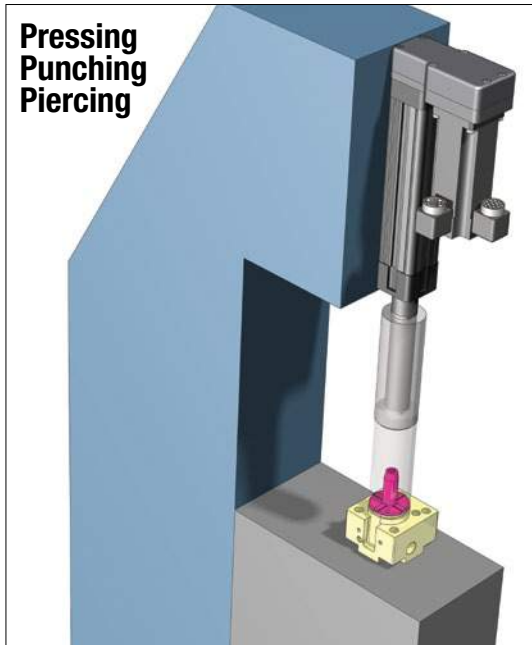

CONTENTS

What is RSA & GSA R/GSA_2
 Rod-Style Actuators R/GSA_2
 Applications R/GSA_3
 RSA ST Features R/GSA_4-5
 RSA HT Features R/GSA_6-7
 GSA Features R/GSA_8-9

SPECIFICATIONS

Critical Speed R/GSA_10-12
 PV Limits R/GSA_12-13
 Life Capacities R/GSA_14
 Buckling Load R/GSA_15
 RSA Screw/Nut R/GSA_17
 RSM Screw/Nut R/GSA_18
 GSA Screw/Nut R/GSA_19-20
 GSM Screw/Nut R/GSA_21-22
 Actuator R/GSA_23
 GSA Load & Defl R/GSA_24-27

DIMENSIONS

RSA Actuator R/GSA_28-29
 RSA & GSA R/GSA_30-31
 RSA Rod End Opt R/GSA_32-33
 RSA Mounting Opt R/GSA_34-37

SWITCHES R/GSA_38-39

Appl. Data Worksheet R/GSA_40
 Selection Guidelines R/GSA_41

ORDERING R/GSA_42-43

Other Applications:

- Animation
- Assembly machinery
- Automatic tool changers
- Automotive
- Clamping
- Converting
- Conveyors
- Cycle testing
- Filers
- Formers
- Hydraulic replacement
- Laser positioning
- Machine tools
- Material handling
- Medical equipment
- Molding
- Motion simulators
- Open / close doors
- Packaging equipment
- Parts clamping
- Patient lifts
- Pick & place
- Pneumatic replacement
- Precision grinders
- Product test simulations
- Riveting / fastening / joining
- Robot manipulator arms
- Sawmill equipment
- Semiconductor
- Stage motion control
- Stamping
- Table positioning
- Tension control
- Test stands
- Tube bending
- Volumetric pumps
- Water jet control
- Wave generation
- Web guidance
- Welding
- Wire winding
- and many more

Sold & Serviced By:
 ELECTROMATE

Toll Free Phone (877) SERV098
 Toll Free Fax (877) SERV099
 www.electromate.com
 sales@electromate.com

RSA-ST ROD-STYLE ACTUATOR

ENDURANCE TECHNOLOGYSM

Endurance Technology features are designed for maximum durability to provide extended service life.

The RSA rod screw actuator is ideal for medium to high thrust applications of guided loads. The compact design and cylinder style operation make this solution ideal for applications that were historically solved with pneumatic or hydraulic power. Many mounting options are available allowing the actuator to be installed in numerous applications. Built-to-order in stroke lengths up to 60 inches with your choice of screw technology.

• HIGH POSITIONAL ACCURACY •

SCREW ACCURACY

| | | |
|-----------------|-------------------|----------------------|
| Roller Nut | $\pm 0.0004"/ft.$ | $\pm 0.0102mm/300mm$ |
| Metric Ball Nut | $\pm 0.002"/ft.$ | $\pm 0.051mm/300mm$ |

• MULTIPLE SCREW TECHNOLOGIES

YOU CAN CHOOSE:

- Solid nuts of bronze or engineered resins offer quiet performance at the lowest cost; anti-backlash available
- Ball nuts offer efficiency at a cost effective price; low-backlash available
- Roller nuts provide the highest thrust and life ratings available (HT option)



• SCREW SUPPORT BEARING •

- Engineered resin bearing provides continuous support of screw

• INTERNAL BUMPERS •

- Bumpers protect the screw and nut assembly from damage at both ends of stroke

• THRUST TUBE •

- Steel thrust tube supports extremely high force capabilities
- Salt bath nitride treatment provides excellent corrosion resistance, surface hardness and is very resistant to adherence of potential contaminants

• THREADED ROD END •

- Provides a common interface to multiple rod end options

• ROD WIPER •

- Prevents contaminants from entering the housing for extended life of the actuator

• NOSE BEARING •

- Support the thrust tube and nut assembly through entire stroke length
- Unique nose bearing material allows for smooth operation and support of the thrust rod

Sold & Serviced By:

ELECTROMATE

Toll Free Phone (877) SERV098

Toll Free Fax (877) SERV099

www.electromate.com

sales@electromate.com

• **YOUR MOTOR HERE** •

YOU CAN CHOOSE:

- Specify the device to be installed and actuator ships with proper mounting hardware
- Specify and ship your device to Tolomatic for factory installation
- Motor or gearbox supplied and installed by Tolomatic

• **MOTOR ORIENTATION** •

YOU CAN CHOOSE:

- Inline option directly couples the driving shaft and is typically a one-piece housing construction for optimum alignment and support of the motor
- Reverse-parallel option minimizes the overall length and offers a belt reduction drive with a 1:1 or 2:1 ratio

HIGH THRUST BEARING

- Unique high thrust bearing assembly design eliminates runout and isolates the linear forces for the drive shaft

• **BREATHER / PURGE PORTS** •

- Standard feature on RSA 32,50,64 size actuators
- As seen in this view, located on both the bottom and the opposite side of the actuator

• Use as **Breather Port:**

allows air flow into the interior of the actuator. Prevents additional load on the motor caused by air buildup due to fast cycling of the RSA. Use as **Purge Port:** positive pressure with air lines and filters insure contaminants (*which could potentially shorten the actuator life*) do not enter the interior of the actuator.

LIGHTWEIGHT ALUMINUM DESIGN

- Black anodized extrusion design is optimized for rigidity and strength
- External switch channels on all sides allow easy placement of position indicating switches

• **INTERNAL NUT BEARINGS** •

- Engineered resin guide bearings provide anti-rotation of the thrust rod
- Support the thrust tube and nut assembly through entire stroke length

Sold & Serviced By:



Toll Free Phone (877) SERV098
Toll Free Fax (877) SERV099
www.electromate.com
sales@electromate.com



OPTIONS

See page 7 for a complete list of RSA options including the HT-high torque option

RSA-HT OPTION

ENDURANCE TECHNOLOGYSM

The HT option is a higher thrust option for the 32, 50 and 64 sizes of the RSA family. RSA actuators with roller nuts are always HT option actuators. Use Tolomatic's online sizing software to determine if the HT Option is right for your application

ACTUATOR



SIZING

REDESIGNED LMI & RP HOUSING

- Available on all inline and 64 size RP mounts. Specially designed to accommodate larger motors & gearboxes with higher torques and larger bolt circles (up to 6.5", 165mm)

DURABLE BELT MATERIAL

- High torque polyurethane timing belt with carbon tensile cords resists stretching

STANDARD FEATURES

See page 4 for a complete list of RSA standard features

Sold & Service by
 **ELECTROMATE**

Toll Free Phone (877) SERV098
Toll Free Fax (877) SERV099
www.electromate.com
sales@electromate.com

ENHANCED HIGH THRUST BEARING

- RSA HT actuators come with high thrust angular contact ball bearing in matched pair assembly design eliminates runout and isolates the linear forces for the drive shaft

WHY CHOOSE THE HT OPTION?

- Higher strength components transfer torque from the gearhead/motor through the actuator
- Grease zerks allows convenient relubrication for extended screw service life
- Allows convenient addition of gearbox to RP (Reverse Parallel mount) actuator
- Accommodates mounting large motors with up to 165mm bolt circle pattern

YOUR MOTOR HERE (Standard Feature) YOU CAN CHOOSE:

- Specify the device to be installed (keyed shaft required) and actuator ships with proper mounting hardware
- Specify and ship your device to Tolomatic for factory installation
- Motor or gearbox supplied and installed by Tolomatic

IP67 OPTION

- Resist water ingress 1m deep for up to 30 min

HEAVY DUTY INTERNAL BUMPERS

- Bumpers protect the screw and nut assembly from damage at both ends of stroke

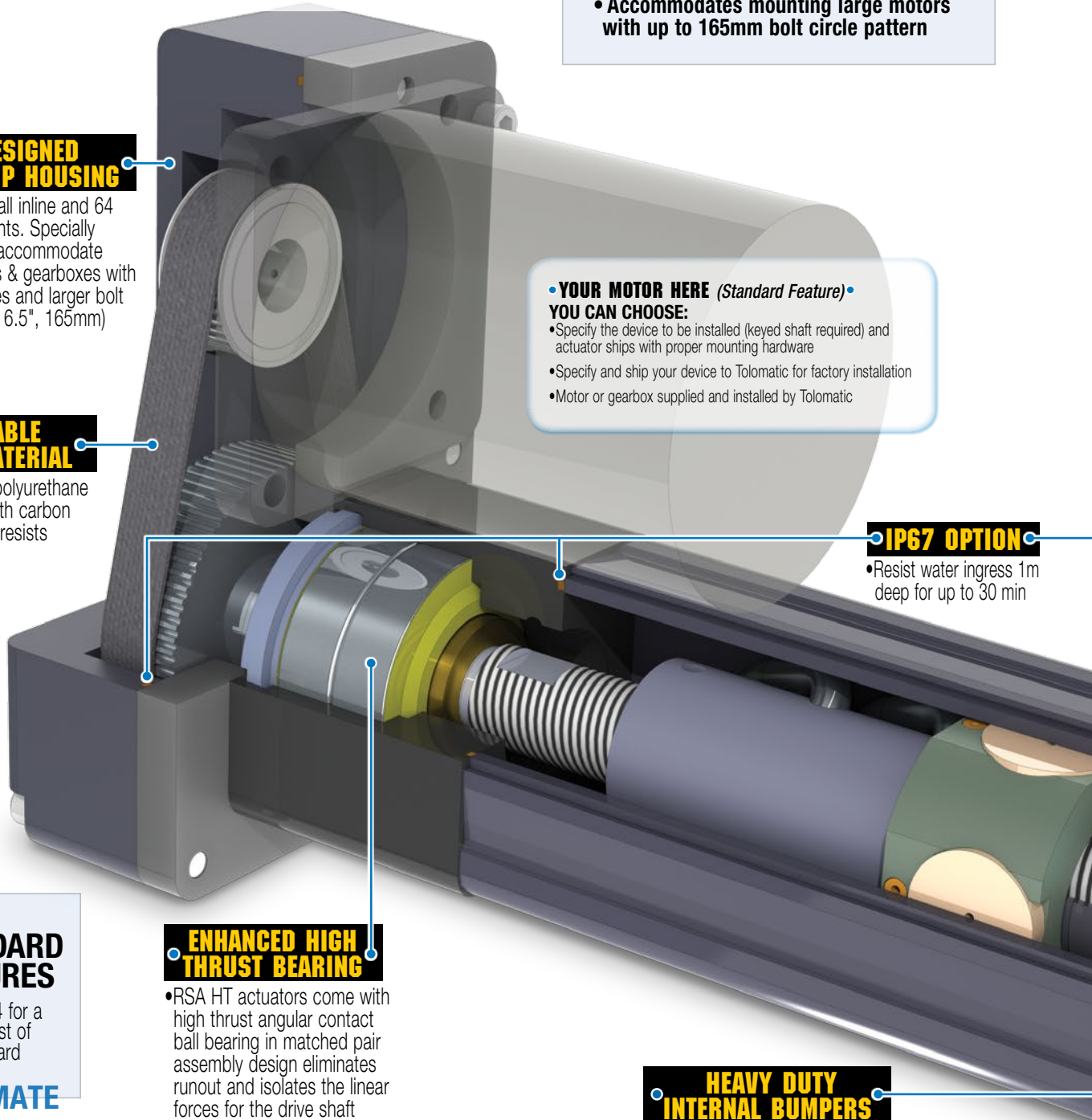

OPTIONS (Available for all RSA actuators unless noted)

• METRIC OPTION

Provides metric tapped holes for mounting of load to rod end and of actuator to mating surfaces



• SWITCHES

Choose from: Reed, Solid State PNP or NPN, all available normally open or normally closed

• IP67

Static: special gaskets for basic protection against water and dust ingress
32,50,64 sizes only: HT actuator (LMI and RP); ST actuator (RP motor mount only)

ROD END



• **MET: External Threads**
male threads

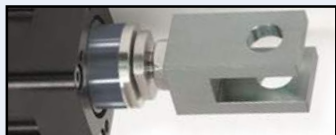

• **CLV: Clevis Rod End**
for pivoting mount



• **SRE: Spherical Rod End**
for pivoting mount



• **ALC: Alignment Coupler Rod End**
to compensate for mounting alignment



• **XR: Rod Extension**
to separate load from the actuator

MOUNTING



• **MP2: Mounting Plates**
for surface mounting



• **FFG: Front Flange**
for mounting near rod end



• **TRR: Trunnion Mount**
for pivoting mount

Below are for RP Motor mounting only



• **FM2: Foot Mount**
for surface or end mounting



• **BFG: Rear Flange**
for mounting opposite the rod end



• **PCD: Clevis**
• **PCS: Eye Mount**
for pivoting mount

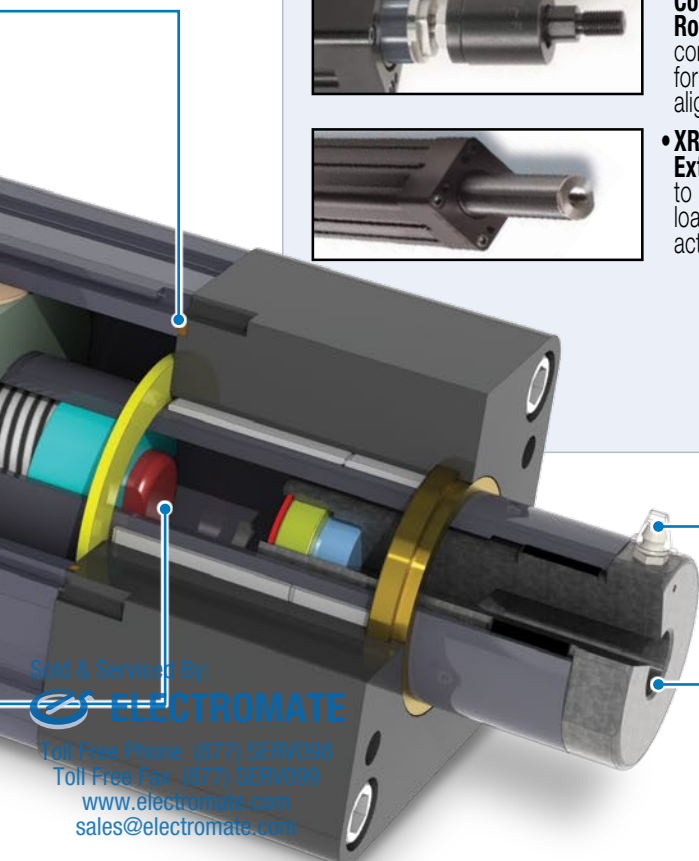

GREASE ZERK

• This relubrication system provides extended screw service life

• Convenient lubrication without disassembly

• Standard with all HT option RSA actuators



THREADED ROD END

• Provides a common interface to multiple rod end options

Sold & Serviced By:

ELECTROMATE

Toll Free Phone (877) SERV096

Toll Free Fax (877) SERV099

www.electromate.com

sales@electromate.com

GSA GUIDED ROD-STYLE ACTUATOR

ENDURANCE TECHNOLOGYSM

Endurance Technology features are designed for maximum durability to provide extended service life.

The GSA guided screw actuator is ideal for medium to high thrust applications. The self-contained guided rod design and cylinder slide style operation make this solution ideal for applications requiring guidance and support of the load. A robust, wide tooling plate allows easy mounting of the required end effectors for many applications. Built-to-order in stroke lengths up to 36 inches with your choice of screw technology.

MULTIPLE SCREW TECHNOLOGIES

YOU CAN CHOOSE:

- Solid nuts of bronze or engineered resins offer quiet performance at the lowest cost; anti-backlash available
- Ball nuts offer efficiency at a cost effective price; low-backlash available
- Roller nuts provide the highest thrust and life ratings available



LIGHTWEIGHT ALUMINUM DESIGN

- Black anodized bearing block provides solid structural support and multiple mounting options
- Black anodized tube extrusion design is optimized for rigidity and strength
- External switch channels on all sides allow easy placement of position indicating switches

ROD WIPER

- Prevents contaminants from entering the housing for extended life of the actuator

ANODIZED ALUMINUM THRUST TUBE

- Lightweight design directly provides thrust with minimal additional inertia
- Corrosion resistant plating provides excellent protection from many chemicals

INTEGRAL GUIDE RODS AND BEARINGS

- Hardened steel guide rods provide high rigidity and low deflection
- Four composite or linear ball bearings support the load for smooth, consistent motion

- Lubrication wick supplies lube for life of actuator
- Oversized rods available for higher load capacity

- Stainless steel shafting option available for corrosion resistance

Sold & Serviced By
ELECTROMATE

Toll Free Phone (877) SERV/098
Toll Free Fax (877) SERV/099
www.electromate.com
sales@electromate.com

YOUR MOTOR HERE

YOU CAN CHOOSE:

- Specify the device to be installed and actuator ships with proper mounting hardware
- Specify and ship your device to Tolomatic for factory installation
- Motor or gearbox supplied and installed by Tolomatic

MOTOR ORIENTATION

YOU CAN CHOOSE:

- Inline option directly couples the driving shafts and is typically a one-piece housing construction for optimum alignment and support of the motor
- Reverse-parallel option minimizes the overall length and offers a 1:1 or 2:1 belt ratio

SCREW SUPPORT BEARINGS

- Unique high thrust bearing assembly design eliminates runout and isolates the linear forces for the drive shaft
- Engineered resin bearing provides continuous support of screw

PRECISION MACHINED SURFACES

- Extruded bearing housing is precision machined on two surfaces for true and easily aligned linear motion
- Tooling plate is aligned and assembled to provide a precise mounting surface

OPTIONS



OVERSIZED GUIDE RODS

Available for increased load capacity or decreased deflection



STOP COLLARS

Provide a positive stop mechanism when required



CORROSION RESISTANCE

Includes 316 stainless steel guide rods and fasteners for better environmental protection

METRIC OPTION

Provides metric tapped holes for mounting of load to tooling plate and of actuator to mating surfaces



SWITCHES

Choose from: Reed, Solid State PNP or NPN, all available normally open or normally closed

Sold & Serviced By:

ELECTROMATE

Toll Free Phone (877) SERV098

Toll Free Fax (877) SERV099

www.electromate.com

sales@electromate.com

RSA & GSA Electric Rod-Style Actuator

SIZE: 12,16: **CRITICAL SPEED CAPACITIES**

PERFORMANCE

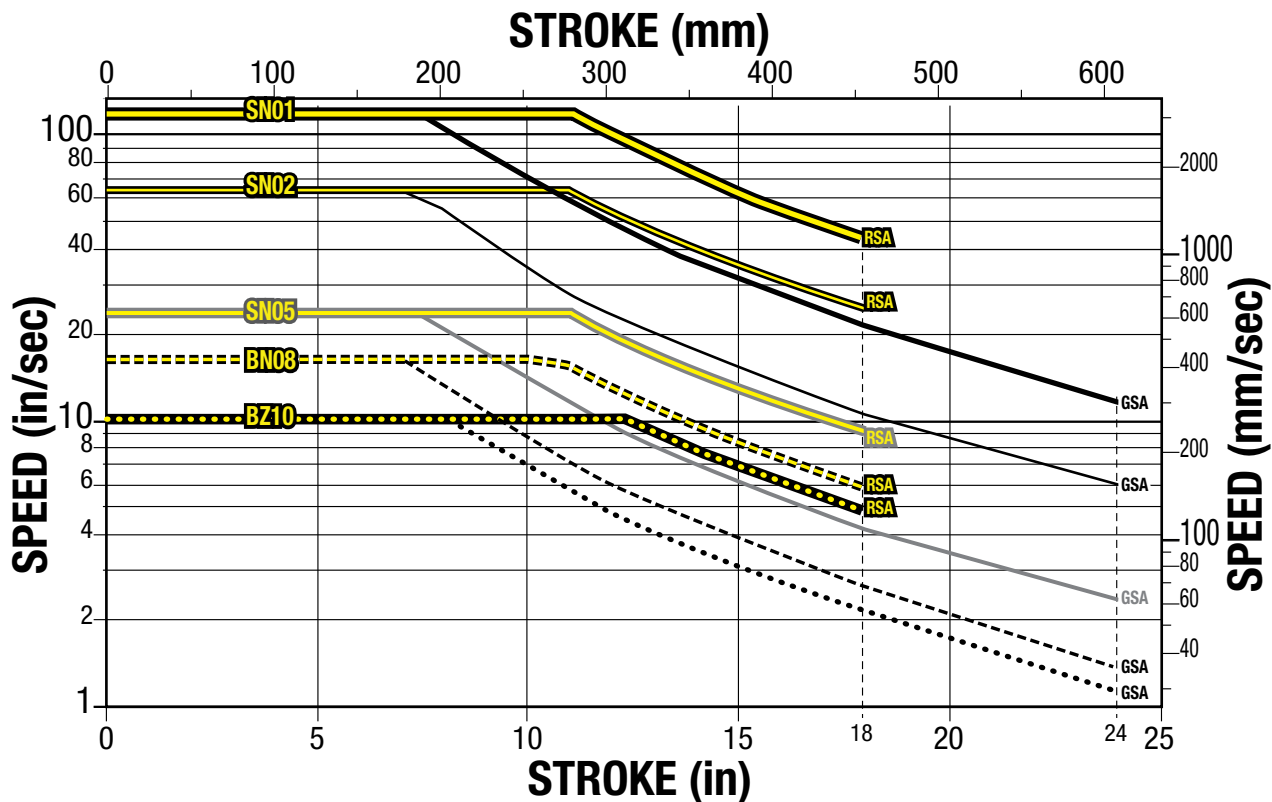

| SCREW CODE | DESCRIPTION |
|------------|-----------------------|
| BN | Ball Nut |
| BNH | Ball Nut H-series |
| BNL | Low-Backlash Ball Nut |
| BNM | Ball Nut Metric |
| BZ | Bronze Nut |
| RN | Roller Nut |
| SN | Solid Nut |

SIZE: 24: **CRITICAL SPEED CAPACITIES**

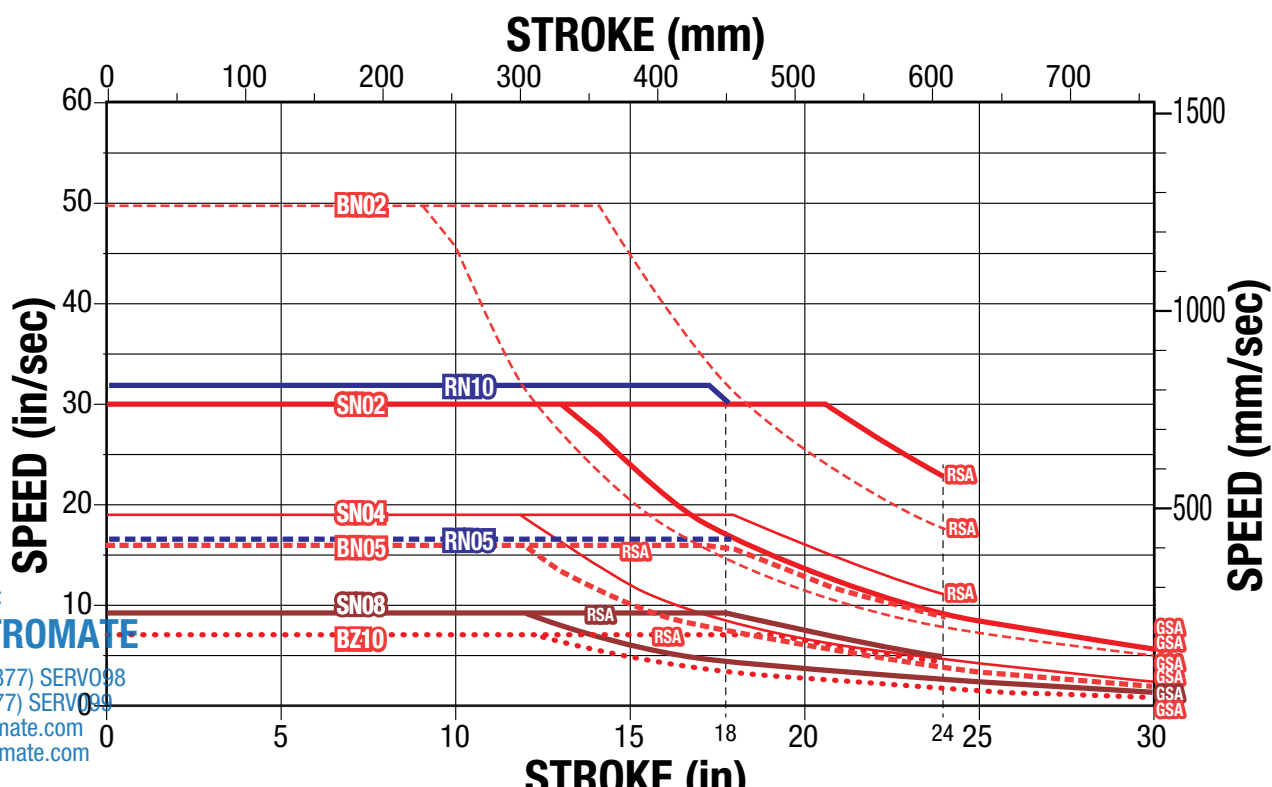

RSA & GSA Electric Rod-Style Actuator

SIZE: 32: **CRITICAL SPEED CAPACITIES**

PERFORMANCE

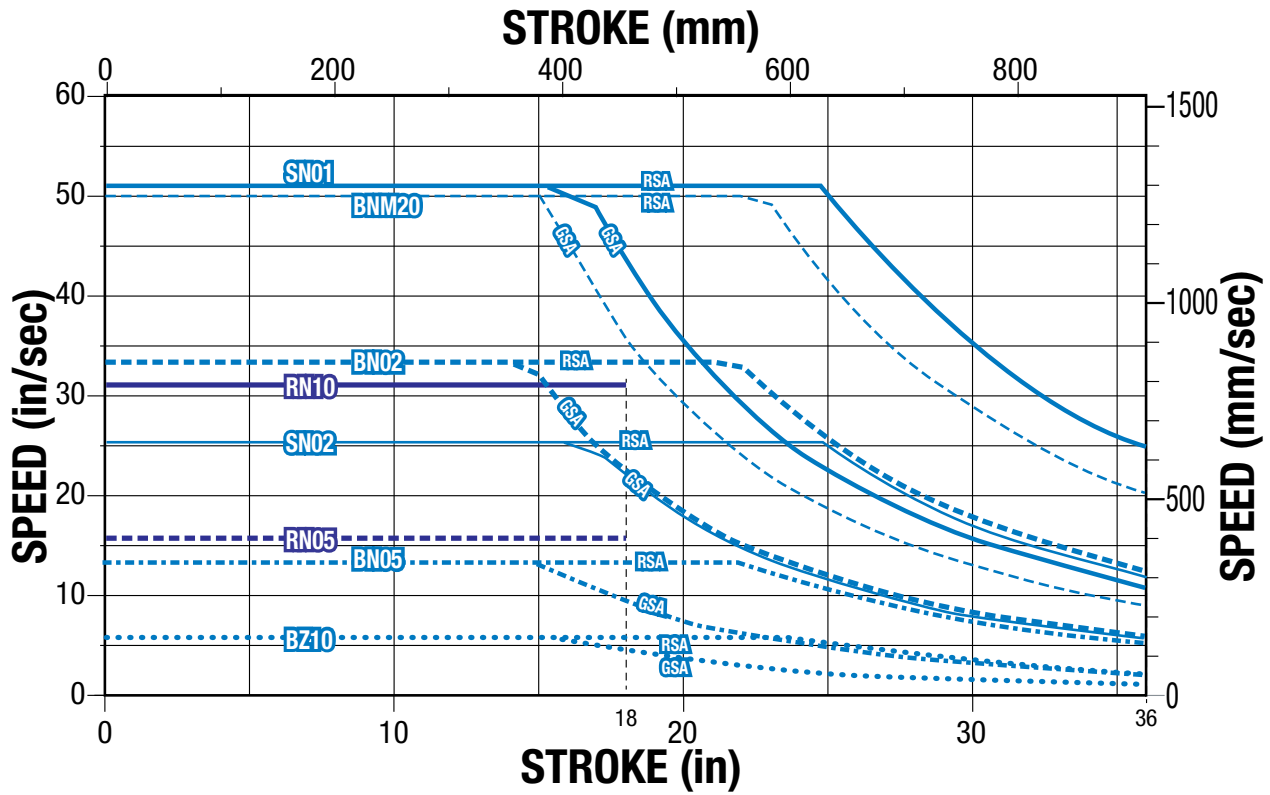

| SCREW CODE | DESCRIPTION |
|------------|-----------------------|
| BN | Ball Nut |
| BNH | Ball Nut H-series |
| BNL | Low-Backlash Ball Nut |
| BNM | Ball Nut Metric |
| BZ | Bronze Nut |
| RN | Roller Nut |
| SN | Solid Nut |

SIZE: 50: **CRITICAL SPEED CAPACITIES**

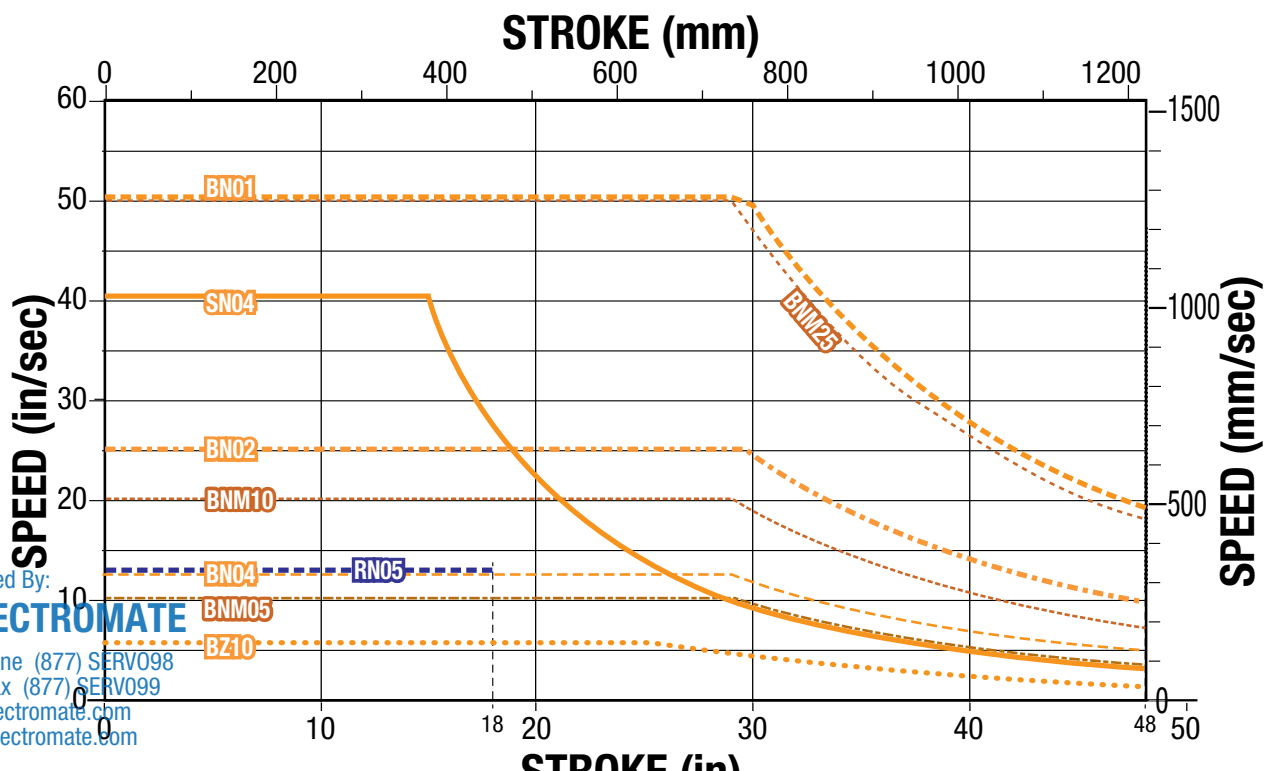

Sold & Serviced By:

 Toll Free Phone (877) SERV098
 Toll Free Fax (877) SERV099
www.electromate.com
sales@electromate.com

RSA & GSA Electric Rod-Style Actuator

SIZE: 64: **CRITICAL SPEED CAPACITIES**

PERFORMANCE

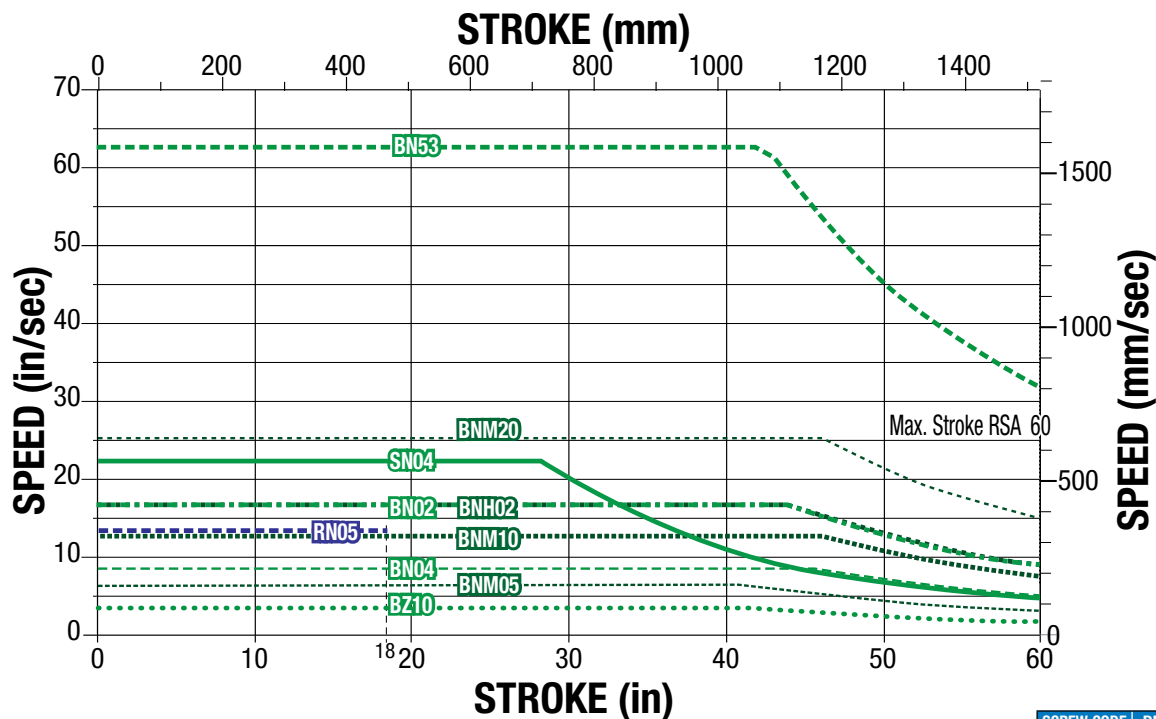

| SCREW CODE | DESCRIPTION |
|------------|-----------------------|
| BN | Ball Nut |
| BNH | Ball Nut H-series |
| BNL | Low-Backlash Ball Nut |
| BNM | Ball Nut Metric |
| BZ | Bronze Nut |
| RN | Roller Nut |
| SN | Solid Nut |

SIZE: 12,16: **PV LIMITS (Solid Nuts)**

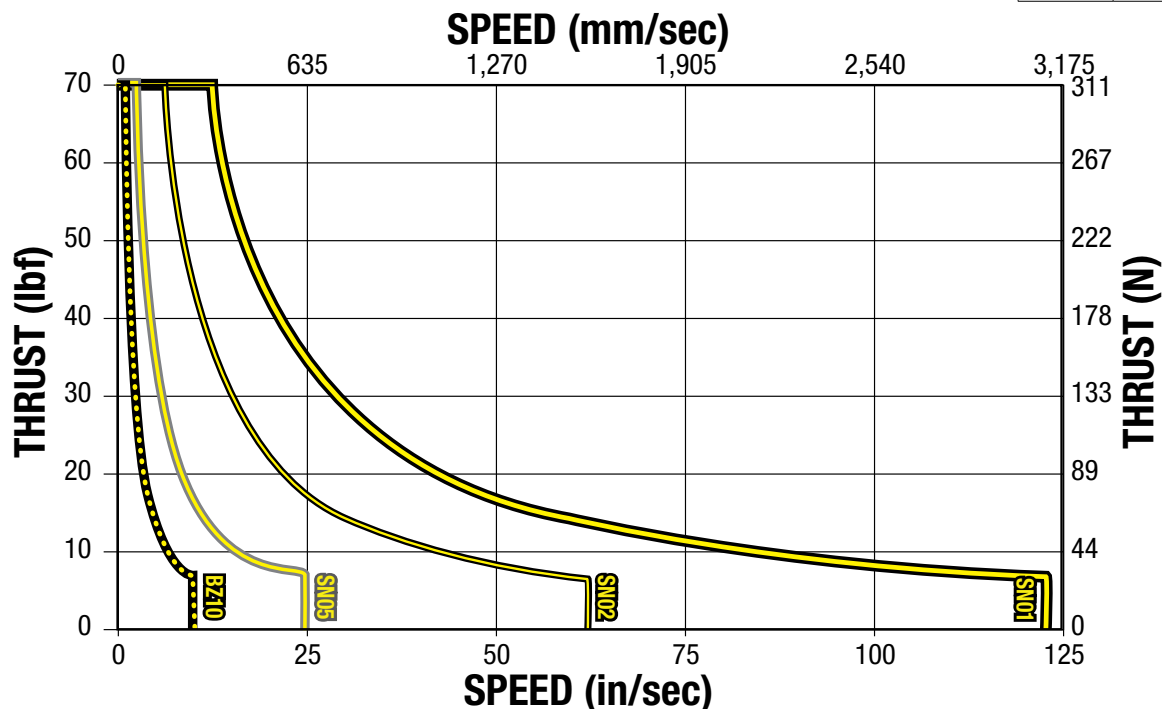

Sold & Serviced By:



Toll Free Phone (877) SERV098
Toll Free Fax (877) SERV099

www.electromate.com
sales@electromate.com

PV LIMITS: Any material which carries a sliding load is limited by heat buildup. The factors that affect heat generation rate in an application are the pressure on the nut in pounds per square inch and the surface velocity in feet per minute. The product of these factors provides a measure of the severity of an application.

$$P \times V \leq 0.1$$

$$\left(\frac{\text{Thrust}}{\text{Area}} \right) \times \left(\frac{\text{Speed}}{\text{ft/min}} \right) < 0.1$$

RSA & GSA Electric Rod-Style Actuator

SIZE: 24,32,50,64 (SN): PV LIMITS (Solid Nuts)

PERFORMANCE

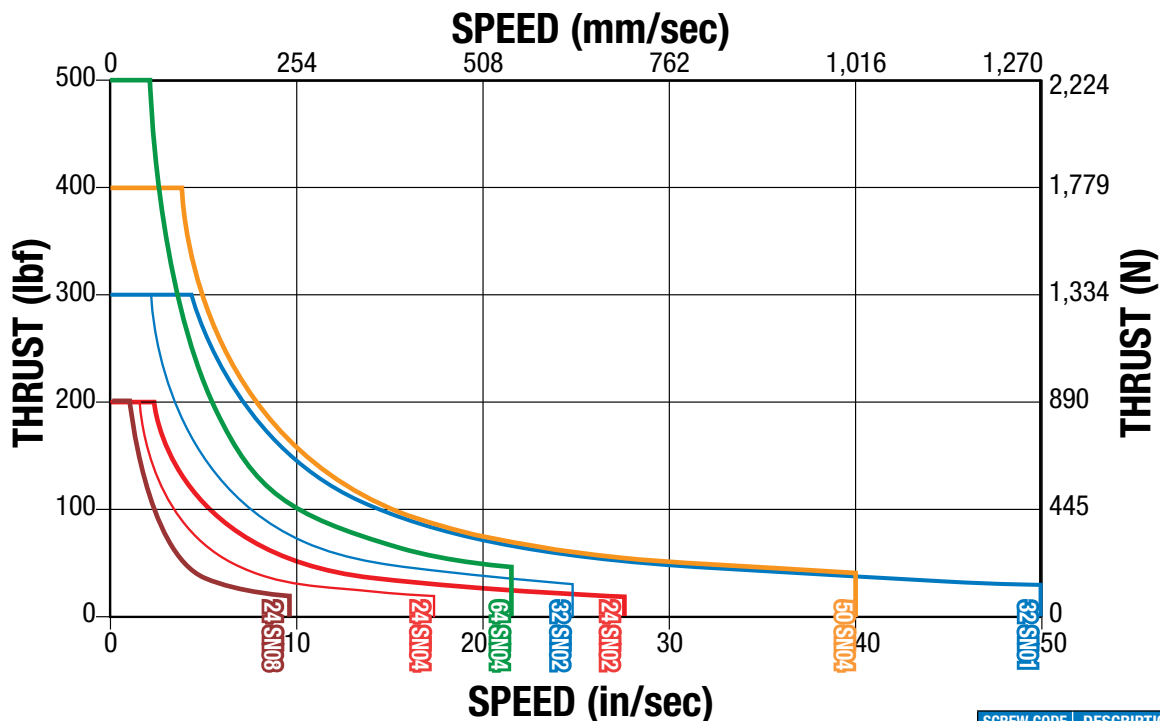

| SCREW CODE | DESCRIPTION |
|------------|-----------------------|
| BN | Ball Nut |
| BNH | Ball Nut H-series |
| BNL | Low-Backlash Ball Nut |
| BNM | Ball Nut Metric |
| BZ | Bronze Nut |
| RN | Roller Nut |
| SN | Solid Nut |

SIZE: 24,32,50,64 (BZ): PV LIMITS (Bronze Nuts)

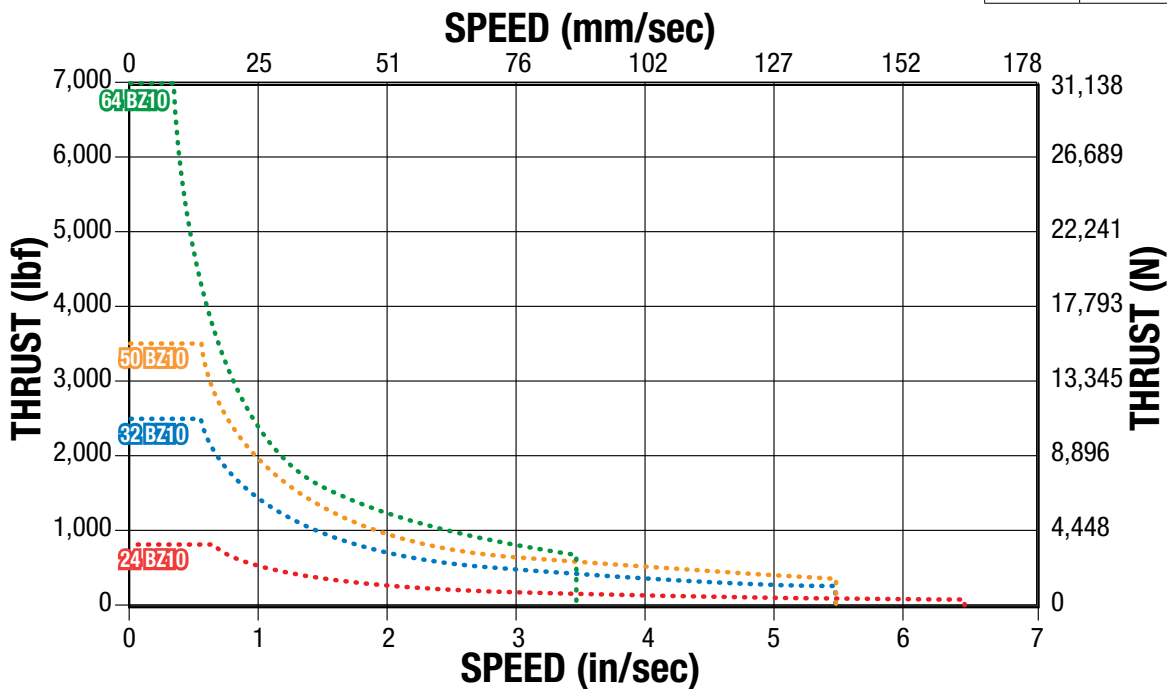

Sold & Serviced By:



Toll Free Phone (877) SERV098

Toll Free Fax (877) SERV099

www.electromate.com

sales@electromate.com

PV LIMITS: Any material which carries a sliding load is limited by heat buildup. The factors that affect heat generation rate in an application are the pressure on the nut in pounds per square inch and the surface velocity in feet per minute. The product of these factors provides a measure of the severity of an application.

$$P \times V \leq 0.1$$

$$\left(\frac{\text{Thrust}}{\text{Area}} \right) \times \left(\frac{\text{Speed}}{\text{Area}} \right) < 0.1$$

RSA & GSA Electric Rod-Style Actuator

BALL & ROLLER SCREW LIFE GRAPHS

SIZE: 12, 16, 24, 32

PERFORMANCE

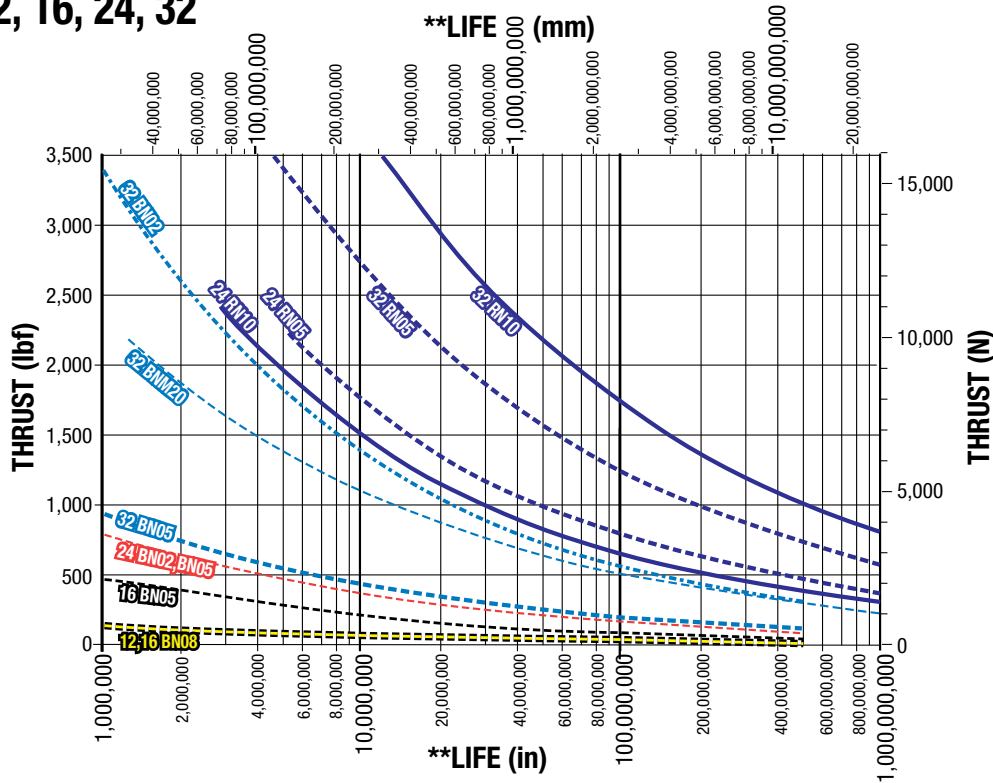

SIZE: 50, 64

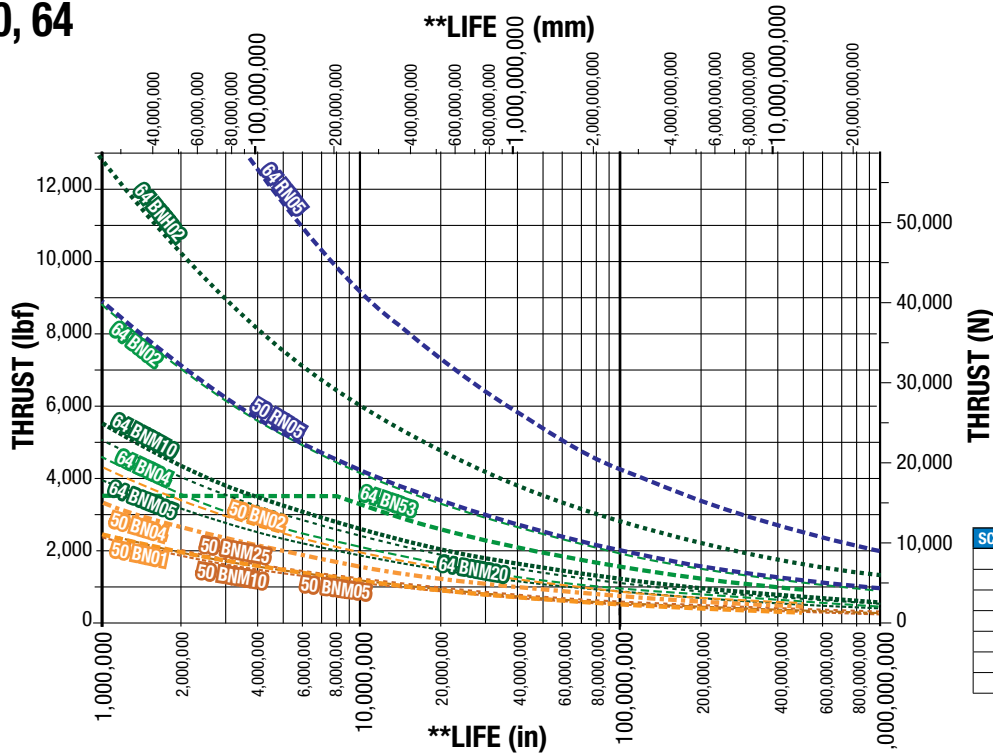

| SCREW CODE | DESCRIPTION |
|------------|-----------------------|
| BN | Ball Nut |
| BNH | Ball Nut H-series |
| BNL | Low-Backlash Ball Nut |
| BNM | Ball Nut Metric |
| BZ | Bronze Nut |
| RN | Roller Nut |
| SN | Solid Nut |



Sold & Serviced By
ELECTROMATE
 1775 SEAVILLE
 TOLL FREE PHONE (877) 537-6968
 TOLL FREE FAX (877) 537-6968
 www.electromate.com
 sales@electromate.com

The underlying formula that defines this value is:

$$L_{10} = \left(\frac{C}{P_e}\right)^3 \cdot l =$$

Travel life in millions of units (in or mm), where:

C = Dynamic load rating (lbf) or (N)

P_e = Equivalent load (lbf) or (N)

Use the "Equivalent Load" calculation below, when the load is not constant throughout the entire stroke. In cases where there is only minor variation in loading, use greatest load for life calculations.

$$P_e = \sqrt[3]{\frac{\% (P_1)^3 + \% (P_2)^3 + \% (P_3)^3 + \% (P_n)^3}{100}}$$

Where:

P_e = Equivalent load (lbs) or (N)

P_n = Each increment at different load (lbs) or (N)

RSA & GSA Electric Rod-Style Actuator

SCREW BUCKLING LOAD

PERFORMANCE

SIZE: 12, 16, 24, 32

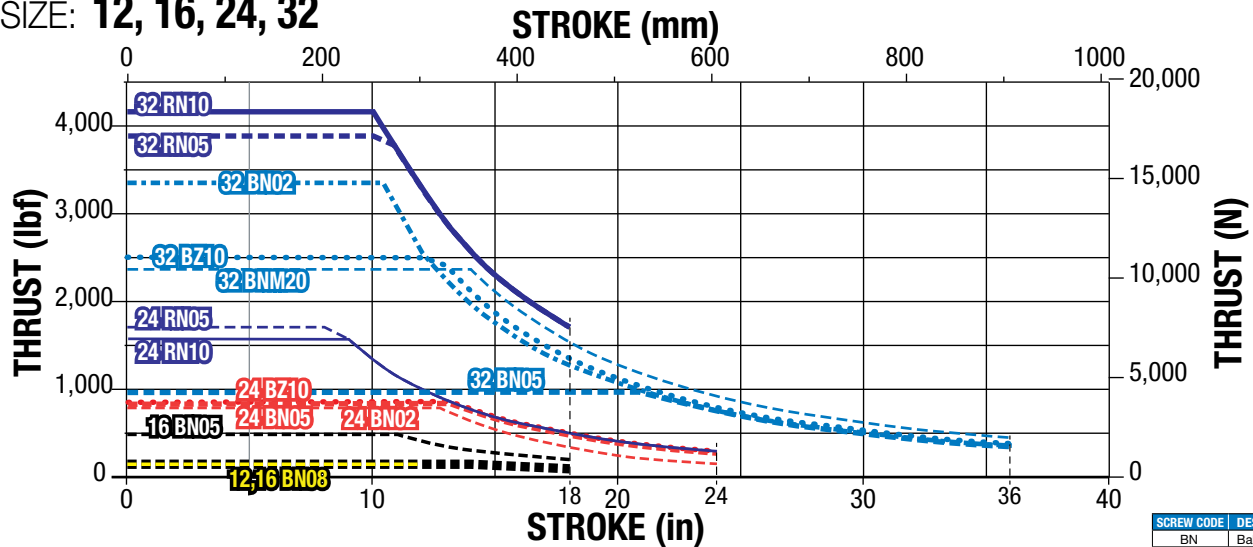

| SCREW CODE | DESCRIPTION |
|------------|-----------------------|
| BN | Ball Nut |
| BNH | Ball Nut H-series |
| BNL | Low-Backlash Ball Nut |
| BNM | Ball Nut Metric |
| BZ | Bronze Nut |
| RN | Roller Nut |
| SN | Solid Nut |

SIZE: 50

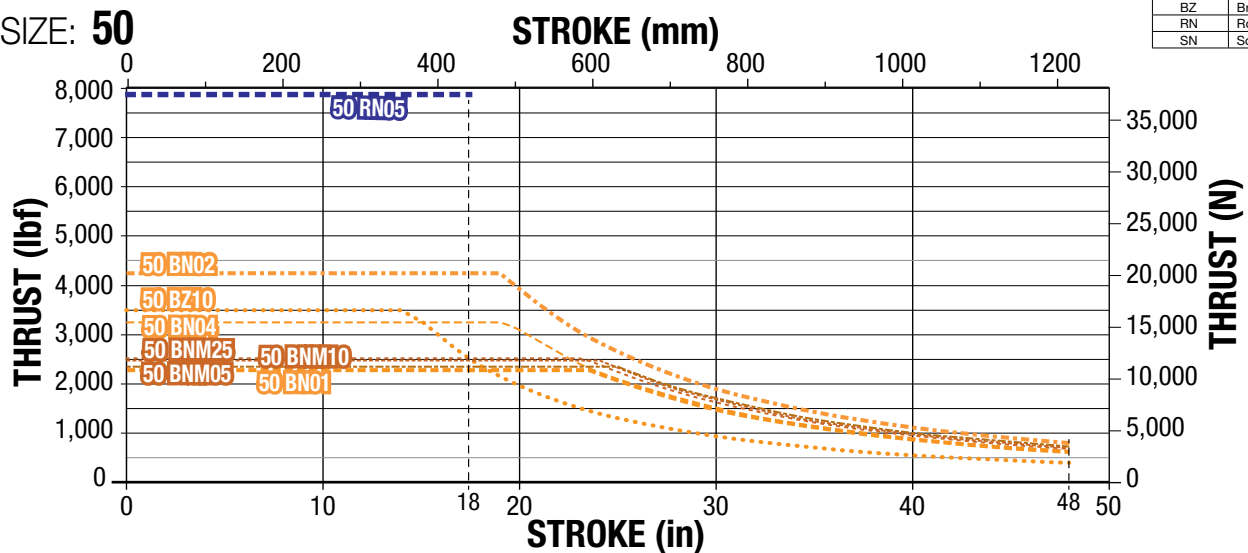

SIZE: 64

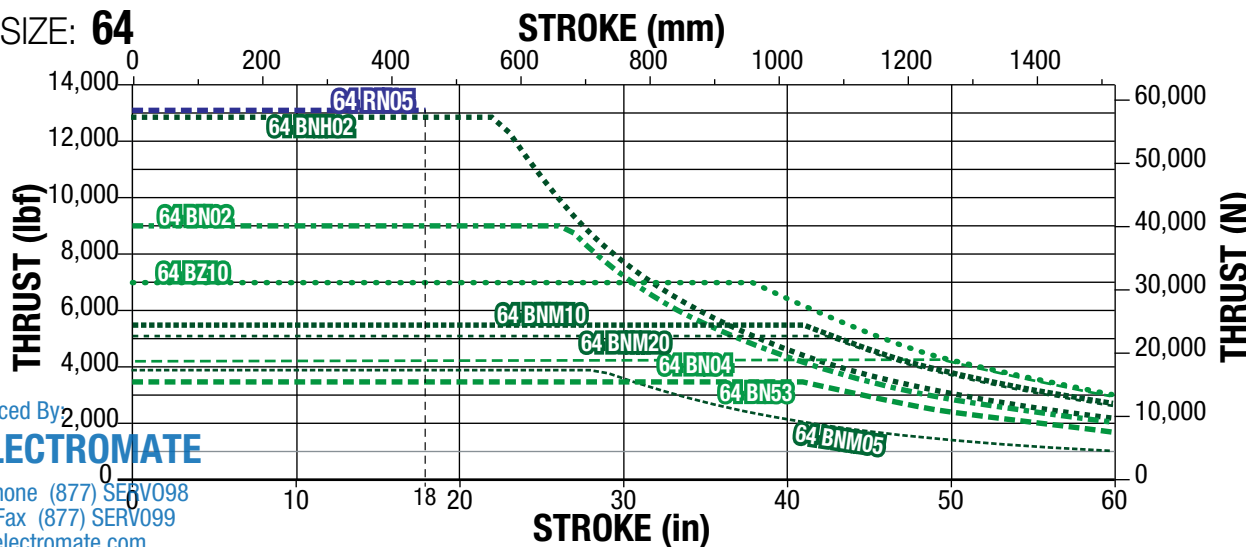

Sold & Serviced By **ELECTROMATE**

Toll Free Phone (877) SERV098
 Toll Free Fax (877) SERV099
 www.electromate.com
 sales@electromate.com

NOTE: Buckling load limits shown assume perfect alignment. It is recommended to use additional safety margin, particularly in high thrust applications.

RSA Electric Rod-Style Actuator

SIZE: 24, 32, 64

SPECIFICATIONS

SPEED vs THRUST, ROLLER SCREW/NUT

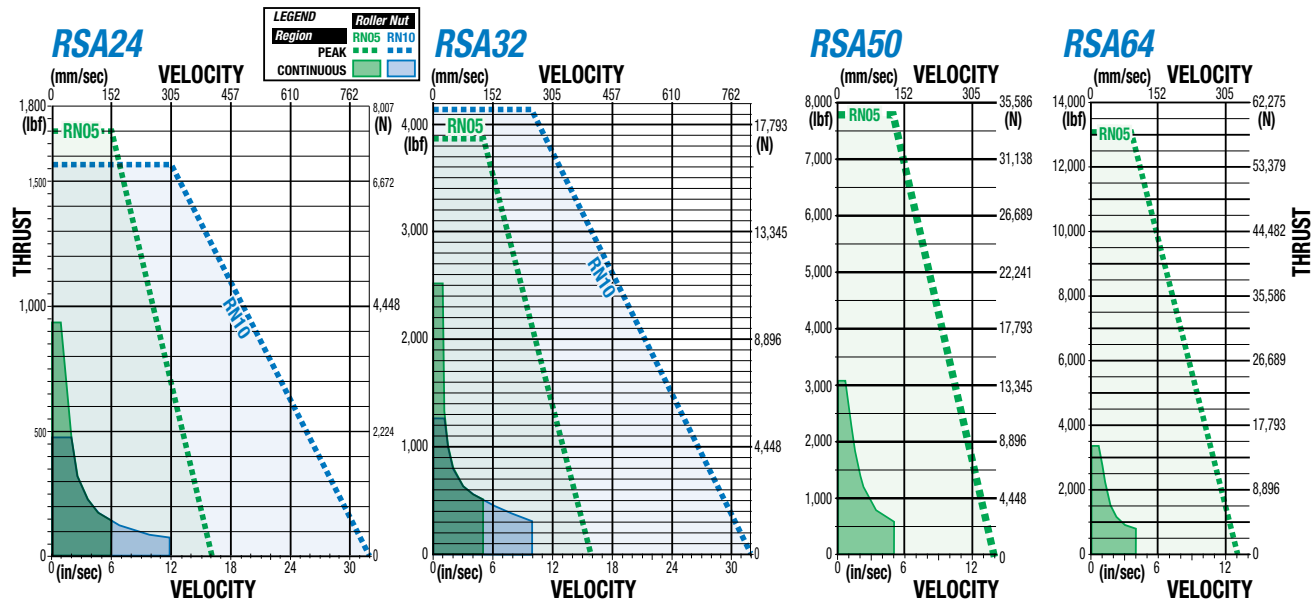

PEAK REGION is the maximum performance capabilities of the actuator system

CONTINUOUS DUTY REGION is defined as the RMS thrust and velocity limit that is derived from the thermal limits of the actuator system to achieve the dynamic load rating of the screw. (Example: Extend and retract under force 100% of the time with no dwells.)

CALCULATING RMS THRUST AND VELOCITY FOR CONTINUOUS DUTY

Roller screw actuator systems have two speed/thrust curves: one for continuous duty operation and another for intermittent (peak) duty. An actuator's roller screw can be selected according to the total thrust and maximum velocity indicated by the continuous duty curve. However, by calculating the root mean square (RMS) thrust based on the application duty cycle, you may be able to take advantage of the higher peak thrust available in the intermittent duty range. The RMS thrust must fall within the continuous duty region of the motor/drive and the application maximum thrust must fall under the peak thrust of the actuator. Use the following formulas when calculating the RMS thrust and velocity. When selecting a servo actuator motor, it is necessary to add a margin of safety to the thrust and velocity required to move the load.

$$T_{RMS} = \sqrt{\frac{\sum (T_i^2 \times t_i)}{\sum (t_i)}}$$

$$V_{RMS} = \sqrt{\frac{\sum (V_i^2 \times t_i)}{\sum (t_i)}}$$

Where:

T_{RMS} = RMS Thrust

V_{RMS} = RMS Velocity

T_i = Thrust during interval i

V_i = Velocity during interval i

t_i = Time interval i

LUBRICATION

RSA roller screw actuators require periodic re-lubrication to maintain optimal performance. Below are formulas to help determine lubrication interval. See parts sheets for formula definitions, complete instructions and examples.

STEP 1: $t_{BL} = 4500 \times (V_{RMS})^{-1.57}$ (hours)

STEP 2: $K_T = K_{Co} \left(\frac{T_{PEAK}}{T_{MAX}} \right) - 0.15$

STEP 3: $t_L = t_{BL} \times K_T$ (hours)

| | 24RN05 | 24RN10 | 32RN05 | 32RN10 | 50RN05 | 64RN05 |
|----------|--------|--------|--------|--------|--------|--------|
| K_{Co} | 0.24 | 0.44 | 0.26 | 0.40 | 0.31 | 0.31 |

Re-lubricate with Tolomatic Grease into the grease zerk located on the rod end.

| | RSA24 | RSA32 | RSA50 | RSA64 |
|----------|----------------|----------------|----------------|-----------------|
| Quantity | 0.11 oz (3.0g) | 0.18 oz (5.0g) | 0.28 oz (8.0g) | 0.35 oz (10.0g) |



In some applications oil may leak from the grease zerk. In contamination sensitive applications replace grease zerk with plug.

Where:

t_{BL} = Basic Lubrication Interval (hours)

V_{RMS} = RMS Velocity (in/sec)

K_T = Thrust Correction Factor

K_{Co} = Screw Static Load Factor

T_{PEAK} = Actuator Peak Thrust Rating

T_{MAX} = Maximum Cycle Thrust

t_L = Lubrication Interval (hours)

Sold & Serviced By:

ELECTROMATE

Toll Free Phone (877) SERV098

Toll Free Fax (877) SERV099

www.electromate.com

sales@electromate.com

RSA Electric Rod-Style Actuator

SIZE: **ALL**

units: **US standard**

SPECIFICATIONS

| RSA SIZE | MAX. STROKE in | SCREW DIA. in | SCREW CODE | TPI turns/in | LEAD ACCURACY in/ft | BACKLASH in | MAX. THRUST* lbf | DYNAMIC LOAD RATING** lbf | BASE ACTUATOR INERTIA | | INERTIA PER/in OF STROKE lb-in ² | BREAK-AWAY TORQUE lb-in | MOVING PARTS WEIGHT | |
|----------|-------------------|------------------|------------|-----------------|---------------------------|----------------|---------------------|------------------------------|-------------------------------|--|--|----------------------------|---------------------|----------------|
| | | | | | | | | | In Line lb-in ² | Reverse Parallel lb-in ² | | | Base lb | Per Inch lb |
| 12 | 18 | 0.375 | SN01 | 1.00 | 0.0100 | 0.0070 | 70 | NA | 0.004 | 0.005 | 0.002 | 0.63 | 0.11 | 0.04 |
| | 18 | 0.375 | SN02 | 2.00 | 0.0060 | 0.0070 | 70 | NA | 0.002 | 0.003 | 0.001 | 0.56 | 0.11 | 0.04 |
| | 18 | 0.375 | SN05 | 5.00 | 0.0060 | 0.0070 | 70 | NA | 0.002 | 0.002 | 0.001 | 0.50 | 0.11 | 0.04 |
| | 18 | 0.375 | BZ10 | 10.00 | 0.0060 | 0.0080 | 70 | NA | 0.002 | 0.002 | 0.001 | 0.50 | 0.11 | 0.04 |
| | 18 | 0.375 | BN08 | 8.00 | 0.0030 | 0.0150 | 130 | 260 | 0.002 | 0.002 | 0.001 | 0.50 | 0.19 | 0.04 |
| | 18 | 0.375 | BNL08 | 8.00 | 0.0030 | 0.0020 | 130 | 260 | 0.002 | 0.002 | 0.001 | 0.50 | 0.19 | 0.04 |
| 16 | 18 | 0.375 | SN01 | 1.00 | 0.0100 | 0.0070 | 70 | NA | 0.006 | 0.007 | 0.002 | 1.31 | 0.19 | 0.06 |
| | 18 | 0.375 | SN02 | 2.00 | 0.0060 | 0.0070 | 70 | NA | 0.003 | 0.003 | 0.001 | 1.13 | 0.19 | 0.06 |
| | 18 | 0.375 | SN05 | 5.00 | 0.0060 | 0.0070 | 70 | NA | 0.002 | 0.002 | 0.001 | 1.06 | 0.19 | 0.06 |
| | 18 | 0.375 | BZ10 | 10.00 | 0.0060 | 0.0080 | 70 | NA | 0.002 | 0.002 | 0.001 | 1.06 | 0.19 | 0.06 |
| | 18 | 0.375 | BN08 | 8.00 | 0.0030 | 0.0150 | 130 | 260 | 0.002 | 0.002 | 0.001 | 1.00 | 0.27 | 0.06 |
| | 18 | 0.375 | BNL08 | 8.00 | 0.0030 | 0.0020 | 130 | 260 | 0.002 | 0.002 | 0.001 | 1.00 | 0.27 | 0.06 |
| 24 | 24 | 0.625 | SN02 | 2.00 | 0.0050 | 0.0070 | 200 | NA | 0.022 | 0.023 | 0.005 | 1.81 | 0.75 | 0.14 |
| | 24 | 0.625 | SN04 | 4.00 | 0.0100 | 0.0070 | 200 | NA | 0.019 | 0.019 | 0.004 | 1.69 | 0.75 | 0.14 |
| | 24 | 0.625 | SN08 | 8.00 | 0.0100 | 0.0070 | 200 | NA | 0.018 | 0.018 | 0.004 | 1.63 | 0.75 | 0.14 |
| | 24 | 0.625 | BZ10 | 10.00 | 0.0060 | 0.0080 | 850 | NA | 0.018 | 0.018 | 0.004 | 1.63 | 0.75 | 0.14 |
| | 24 | 0.625 | BN05 | 5.00 | 0.0030 | 0.0150 | 825 | 1,411 | 0.021 | 0.021 | 0.004 | 2.19 | 1.01 | 0.14 |
| | 24 | 0.625 | BNL05 | 5.00 | 0.0030 | 0.0020 | 825 | 1,411 | 0.021 | 0.021 | 0.004 | 2.19 | 1.01 | 0.14 |
| | 24 | 0.500 | BN02 | 2.00 | 0.0030 | 0.0150 | 850 | 1,071 | 0.019 | 0.019 | 0.003 | 2.50 | 1.01 | 0.14 |
| | 24 | 0.500 | BNL02 | 2.00 | 0.0030 | 0.0020 | 850 | 1,071 | 0.019 | 0.019 | 0.003 | 2.50 | 1.01 | 0.14 |
| | 18 | 0.591 | RN05 | 5.08 | 0.0004 | 0.0012 | 1,700 | 5,577 | 0.221 | 0.041 | 0.004 | 5.30 | 1.64 | 0.14 |
| | 18 | 0.591 | RN10 | 2.54 | 0.0004 | 0.0012 | 1,556 | 5,577 | 0.227 | 0.047 | 0.004 | 5.30 | 1.64 | 0.14 |
| 32 | 36 | 0.750 | SN01 | 1.00 | 0.0050 | 0.0070 | 188 | NA | 0.077 | 0.073 | 0.013 | 3.13 | 0.97 | 0.15 |
| | 36 | 0.750 | SN02 | 2.00 | 0.0050 | 0.0070 | 300 | NA | 0.059 | 0.055 | 0.010 | 2.69 | 0.97 | 0.15 |
| | 36 | 0.750 | BZ10 | 10.00 | 0.0060 | 0.0080 | 2,500 | NA | 0.053 | 0.049 | 0.009 | 3.13 | 0.97 | 0.15 |
| | 36 | 0.750 | BN02 | 2.00 | 0.0040 | 0.0150 | 2,500 | 3,364 | 0.072 | 0.068 | 0.010 | 2.44 | 1.44 | 0.15 |
| | 36 | 0.750 | BNL02 | 2.00 | 0.0040 | 0.0020 | 2,500 | 3,364 | 0.072 | 0.068 | 0.010 | 2.44 | 1.44 | 0.15 |
| | 36 | 0.750 | BN05 | 5.00 | 0.0030 | 0.0150 | 950 | 1,624 | 0.065 | 0.060 | 0.009 | 2.31 | 1.44 | 0.15 |
| | 36 | 0.750 | BNL05 | 5.00 | 0.0030 | 0.0020 | 950 | 1,624 | 0.065 | 0.060 | 0.009 | 2.31 | 1.44 | 0.15 |
| | 36 | 0.787 | BNM20 | 1.27 | 0.0020 | 0.0050 | 2,364 | 2,560 | 0.080 | 0.075 | 0.011 | 5.60 | 1.44 | 0.15 |
| | 18 | 0.787 | RN05 | 5.08 | 0.0004 | 0.0012 | 3,878 | 13,114 | 1.250 | 1.351 | 0.011 | 6.20 | 3.15 | 0.15 |
| | 18 | 0.787 | RN10 | 2.54 | 0.0004 | 0.0012 | 4,159 | 12,729 | 1.263 | 1.363 | 0.011 | 6.20 | 3.15 | 0.15 |
| 50 | 48 | 1.000 | SN04 | 4.00 | 0.0100 | 0.0070 | 400 | NA | 0.206 | 0.203 | 0.028 | 4.25 | 2.62 | 0.30 |
| | 48 | 1.000 | BZ10 | 10.00 | 0.0060 | 0.0080 | 3,500 | NA | 0.319 | 0.316 | 0.035 | 4.13 | 2.62 | 0.30 |
| | 48 | 1.000 | BN01 | 1.00 | 0.0040 | 0.0150 | 2,300 | 2,300 | 0.319 | 0.316 | 0.035 | 4.13 | 3.55 | 0.30 |
| | 48 | 1.000 | BNL01 | 1.00 | 0.0040 | 0.0020 | 2,300 | 2,300 | 0.319 | 0.316 | 0.035 | 4.13 | 3.55 | 0.30 |
| | 48 | 1.000 | BN02 | 2.00 | 0.0040 | 0.0150 | 4,250 | 5,355 | 0.252 | 0.249 | 0.029 | 3.63 | 3.55 | 0.30 |
| | 48 | 1.000 | BNL02 | 2.00 | 0.0040 | 0.0020 | 4,250 | 5,355 | 0.252 | 0.249 | 0.029 | 3.63 | 3.55 | 0.30 |
| | 48 | 1.000 | BN04 | 4.00 | 0.0040 | 0.0150 | 3,250 | 5,159 | 0.235 | 0.232 | 0.028 | 4.25 | 3.55 | 0.30 |
| | 48 | 1.000 | BNL04 | 4.00 | 0.0040 | 0.0020 | 3,250 | 5,159 | 0.235 | 0.232 | 0.028 | 4.25 | 3.55 | 0.30 |
| | 48 | 0.984 | BNM05 | 5.08 | 0.0020 | 0.0040 | 2,347 | 4,035 | 0.215 | 0.210 | 0.026 | 7.50 | 3.55 | 0.30 |
| | 48 | 0.984 | BNM10 | 2.54 | 0.0020 | 0.0040 | 2,471 | 3,372 | 0.215 | 0.210 | 0.026 | 7.50 | 3.55 | 0.30 |
| | 48 | 0.984 | BNM25 | 1.02 | 0.0040 | 0.0050 | 2,524 | 2,537 | 0.215 | 0.210 | 0.026 | 7.50 | 3.55 | 0.30 |
| | 18 | 1.181 | RN05 | 5.08 | 0.0004 | 0.0012 | 7,868 | 15,736 | 1.950 | 1.846 | 0.060 | 8.50 | 6.77 | 0.30 |
| | 64 | 60 | 1.500 | SN04 | 4.00 | 0.0100 | 0.0070 | 500 | NA | 1.545 | 1.504 | 0.140 | 5.38 | 5.01 |
| 60 | | 1.500 | BZ10 | 10.00 | 0.0060 | 0.0080 | 7,000 | NA | 1.538 | 1.498 | 0.139 | 5.44 | 5.01 | 0.45 |
| 60 | | 1.500 | BN53 | 0.53 | 0.0040 | 0.0150 | 3,500 | 5,961 | 2.500 | 2.459 | 0.180 | 7.19 | 7.59 | 0.45 |
| 60 | | 1.500 | BNL53 | 0.53 | 0.0040 | 0.0020 | 3,500 | 5,961 | 2.500 | 2.459 | 0.180 | 7.19 | 7.59 | 0.45 |
| 60 | | 1.500 | BN02 | 2.00 | 0.0040 | 0.0150 | 9,050 | 11,402 | 1.863 | 1.823 | 0.142 | 5.31 | 7.59 | 0.45 |
| 60 | | 1.500 | BNL02 | 2.00 | 0.0040 | 0.0020 | 9,050 | 11,402 | 1.863 | 1.823 | 0.142 | 5.31 | 7.59 | 0.45 |
| 60 | | 1.500 | BN04 | 4.00 | 0.0040 | 0.0150 | 4,250 | 6,746 | 1.827 | 1.787 | 0.140 | 5.38 | 7.59 | 0.45 |
| 60 | | 1.500 | BNL04 | 4.00 | 0.0040 | 0.0020 | 4,250 | 6,746 | 1.827 | 1.787 | 0.140 | 5.38 | 7.59 | 0.45 |
| 60 | | 1.575 | BNM05 | 5.08 | 0.0020 | 0.0040 | 3,906 | 6,714 | 3.030 | 2.950 | 0.170 | 9.40 | 7.59 | 0.45 |
| 60 | | 1.575 | BNM10 | 2.54 | 0.0020 | 0.0040 | 5,479 | 7,476 | 3.030 | 2.950 | 0.170 | 9.40 | 7.59 | 0.45 |
| 60 | | 1.575 | BNM20 | 1.27 | 0.0020 | 0.0050 | 5,105 | 5,528 | 3.030 | 2.950 | 0.170 | 9.40 | 7.59 | 0.45 |
| 60 | | 1.500 | BNH02 | 2.00 | 0.0040 | 0.0150 | 12,900 | 16,253 | 2.875 | 2.800 | 0.140 | 9.40 | 7.59 | 0.45 |
| 60 | | 1.500 | BNHL02 | 2.00 | 0.0040 | 0.0020 | 12,900 | 16,253 | 2.875 | 2.800 | 0.140 | 9.40 | 7.59 | 0.45 |
| 18 | | 1.417 | RN05 | 5.08 | 0.0004 | 0.0012 | 13,039 | 21,973 | 2.590 | 2.520 | 0.125 | 9.40 | 12.88 | 0.45 |

Sold & Served By:



Toll Free Phone (877) 867V094
Toll Free Fax (877) 588V099

www.electromate.com
sales@electromate.com

| SCREW CODE | DESCRIPTION |
|------------|-------------|
| BZ | Bronze Nut |
| RN | Roller Nut |



Contact Tolomatic for higher accuracy and lower backlash options.
* For SN & BZ screws, maximum continuous dynamic thrust subject to Thrust x Velocity limitation.

** For BN, RN & RN rollers, maximum dynamic thrust is 90% of static thrust for 1 million operations.

RSM Electric Rod-Style Actuator

SIZE: **ALL** units: **metric****

SPECIFICATIONS

** RSM metric actuators use the same leadscrew as the RSA inch actuators. Threaded mounting and dowel pin holes are metric.

| RSA SIZE | MAX. STROKE mm | SCREW DIA. mm | SCREW CODE | LEAD mm/rev | LEAD ACCURACY mm/300mm | BACKLASH mm | MAX. THRUST* N | DYNAMIC LOAD RATING** N | BASE ACTUATOR INERTIA | | INERTIA PER/in OF STROKE kg-m ² x 10 ⁻⁶ | BREAK-AWAY TORQUE N-m | MOVING PARTS WEIGHT | |
|----------|-------------------|------------------|------------|----------------|---------------------------|----------------|-------------------|----------------------------|---|--|--|--------------------------|---------------------|---------------|
| | | | | | | | | | In Line kg-m ² x 10 ⁻⁶ | Reverse Parallel kg-m ² x 10 ⁻⁶ | | | Base N | Per 25mm N |
| 12 | 457 | 9.53 | SN01 | 25.40 | 0.25 | 0.18 | 311 | NA | 1.287 | 1.375 | 0.4388 | 0.071 | 0.49 | 0.18 |
| | 457 | 9.53 | SN02 | 12.70 | 0.15 | 0.18 | 311 | NA | 0.702 | 0.761 | 0.2340 | 0.064 | 0.49 | 0.18 |
| | 457 | 9.53 | SN05 | 5.08 | 0.15 | 0.18 | 311 | NA | 0.527 | 0.585 | 0.1463 | 0.056 | 0.49 | 0.18 |
| | 457 | 9.53 | BZ10 | 2.54 | 0.15 | 0.20 | 311 | NA | 0.497 | 0.556 | 0.1463 | 0.056 | 0.49 | 0.18 |
| | 457 | 9.53 | BN08 | 3.18 | 0.08 | 0.38 | 578 | 1,157 | 0.497 | 0.585 | 0.1463 | 0.056 | 0.85 | 0.18 |
| | 457 | 9.53 | BNL08 | 3.18 | 0.08 | 0.05 | 578 | 1,157 | 0.497 | 0.585 | 0.1463 | 0.056 | 0.85 | 0.18 |
| 16 | 457 | 9.53 | SN01 | 25.40 | 0.25 | 0.18 | 311 | NA | 1.872 | 1.901 | 0.5850 | 0.148 | 0.85 | 0.27 |
| | 457 | 9.53 | SN02 | 12.70 | 0.15 | 0.18 | 311 | NA | 0.819 | 0.848 | 0.2633 | 0.127 | 0.85 | 0.27 |
| | 457 | 9.53 | SN05 | 5.08 | 0.15 | 0.18 | 311 | NA | 0.527 | 0.556 | 0.1755 | 0.120 | 0.85 | 0.27 |
| | 457 | 9.53 | BZ10 | 2.54 | 0.15 | 0.20 | 311 | NA | 0.468 | 0.497 | 0.1463 | 0.120 | 0.85 | 0.27 |
| | 457 | 9.53 | BN08 | 3.18 | 0.08 | 0.38 | 578 | 1,157 | 0.497 | 0.527 | 0.1463 | 0.113 | 1.20 | 0.27 |
| | 457 | 9.53 | BNL08 | 3.18 | 0.08 | 0.05 | 578 | 1,157 | 0.497 | 0.527 | 0.1463 | 0.113 | 1.20 | 0.27 |
| 24 | 610 | 15.88 | SN02 | 12.70 | 0.13 | 0.18 | 890 | NA | 6.523 | 6.640 | 1.4918 | 0.205 | 3.34 | 0.62 |
| | 610 | 15.88 | SN04 | 6.35 | 0.25 | 0.18 | 890 | NA | 5.470 | 5.616 | 1.2870 | 0.191 | 3.34 | 0.62 |
| | 610 | 15.88 | SN08 | 3.18 | 0.25 | 0.18 | 890 | NA | 5.207 | 5.353 | 1.2285 | 0.184 | 3.34 | 0.62 |
| | 610 | 15.88 | BZ10 | 2.54 | 0.15 | 0.20 | 3,781 | NA | 5.177 | 5.324 | 1.2285 | 0.184 | 3.34 | 0.62 |
| | 610 | 15.88 | BN05 | 5.08 | 0.08 | 0.38 | 3,670 | 6,275 | 5.996 | 6.113 | 1.2578 | 0.247 | 4.49 | 0.62 |
| | 610 | 15.88 | BNL05 | 5.08 | 0.08 | 0.05 | 3,670 | 6,275 | 5.996 | 6.113 | 1.2578 | 0.247 | 4.49 | 0.62 |
| | 610 | 12.70 | BN02 | 12.70 | 0.08 | 0.38 | 3,781 | 4,764 | 5.411 | 5.528 | 0.7605 | 0.282 | 4.49 | 0.62 |
| | 610 | 12.70 | BNL02 | 12.70 | 0.08 | 0.05 | 3,781 | 4,764 | 5.411 | 5.528 | 0.7605 | 0.282 | 4.49 | 0.62 |
| | 457 | 15.01 | RN05 | 5.00 | 0.01 | 0.03 | 7,562 | 24,808 | 64.643 | 11.993 | 1.0530 | 0.599 | 7.30 | 0.64 |
| | 457 | 15.01 | RN10 | 10.00 | 0.01 | 0.03 | 6,921 | 24,808 | 66.485 | 13.806 | 1.1993 | 0.599 | 7.30 | 0.64 |
| 32 | 914 | 19.05 | SN01 | 25.40 | 0.13 | 0.18 | 836 | NA | 22.640 | 21.382 | 3.6563 | 0.353 | 4.31 | 0.67 |
| | 914 | 19.05 | SN02 | 12.70 | 0.13 | 0.18 | 1,334 | NA | 17.258 | 16.000 | 2.8080 | 0.304 | 4.31 | 0.67 |
| | 914 | 19.05 | BZ10 | 2.54 | 0.15 | 0.20 | 11,121 | NA | 15.532 | 14.274 | 2.5448 | 0.353 | 4.31 | 0.67 |
| | 914 | 19.05 | BN02 | 12.70 | 0.10 | 0.38 | 11,121 | 14,964 | 21.148 | 19.890 | 2.8080 | 0.275 | 6.41 | 0.67 |
| | 914 | 19.05 | BNL02 | 12.70 | 0.10 | 0.05 | 11,121 | 14,964 | 21.148 | 19.890 | 2.8080 | 0.275 | 6.41 | 0.67 |
| | 914 | 19.05 | BN05 | 5.08 | 0.08 | 0.38 | 4,226 | 7,226 | 18.925 | 17.667 | 2.5740 | 0.261 | 6.41 | 0.67 |
| | 914 | 19.05 | BNL05 | 5.08 | 0.08 | 0.05 | 4,226 | 7,226 | 18.925 | 17.667 | 2.5740 | 0.261 | 6.41 | 0.67 |
| | 914 | 20.00 | BNM20 | 20.00 | 0.05 | 0.13 | 10,516 | 11,388 | 23.400 | 21.938 | 3.2175 | 0.633 | 6.41 | 0.67 |
| | 457 | 19.99 | RN05 | 5.00 | 0.01 | 0.03 | 17,250 | 58,334 | 365.845 | 395.405 | 3.2175 | 0.701 | 14.01 | 0.66 |
| 457 | 19.99 | RN10 | 10.00 | 0.01 | 0.03 | 18,500 | 56,621 | 369.650 | 398.917 | 3.2175 | 0.701 | 14.01 | 0.66 | |
| 50 | 1219 | 25.40 | SN04 | 6.35 | 0.25 | 0.18 | 1,779 | NA | 60.255 | 59.290 | 8.1900 | 0.480 | 11.65 | 1.33 |
| | 1219 | 25.40 | BZ10 | 2.54 | 0.15 | 0.20 | 15,569 | NA | 93.395 | 92.430 | 10.2668 | 0.466 | 11.65 | 1.33 |
| | 1219 | 25.40 | BN01 | 25.40 | 0.10 | 0.38 | 10,231 | 10,231 | 93.395 | 92.430 | 10.2668 | 0.466 | 15.79 | 1.33 |
| | 1219 | 25.40 | BNL01 | 25.40 | 0.10 | 0.05 | 10,231 | 10,231 | 93.395 | 92.430 | 10.2668 | 0.466 | 15.79 | 1.33 |
| | 1219 | 25.40 | BN02 | 12.70 | 0.10 | 0.38 | 18,905 | 23,820 | 73.681 | 72.686 | 8.5995 | 0.410 | 15.79 | 1.33 |
| | 1219 | 25.40 | BNL02 | 12.70 | 0.10 | 0.05 | 18,905 | 23,820 | 73.681 | 72.686 | 8.5995 | 0.410 | 15.79 | 1.33 |
| | 1219 | 25.40 | BN04 | 6.35 | 0.10 | 0.38 | 14,457 | 22,949 | 68.738 | 67.772 | 8.1900 | 0.480 | 15.79 | 1.33 |
| | 1219 | 25.40 | BNL04 | 6.35 | 0.10 | 0.05 | 14,457 | 22,949 | 68.738 | 67.772 | 8.1900 | 0.480 | 15.79 | 1.33 |
| | 1219 | 25.00 | BNM05 | 5.00 | 0.05 | 0.10 | 10,440 | 17,947 | 62.888 | 61.425 | 7.6050 | 0.847 | 15.79 | 1.33 |
| | 1219 | 25.00 | BNM10 | 10.00 | 0.05 | 0.10 | 10,992 | 14,999 | 62.888 | 61.425 | 7.6050 | 0.847 | 15.79 | 1.33 |
| | 1219 | 25.00 | BNM25 | 25.00 | 0.10 | 0.13 | 11,227 | 11,285 | 62.888 | 61.425 | 7.6050 | 0.847 | 15.79 | 1.33 |
| 457 | 30.00 | RN05 | 5.00 | 0.01 | 0.03 | 34,999 | 69,998 | 570.375 | 539.955 | 17.5500 | 0.960 | 30.11 | 1.33 | |
| 64 | 1524 | 38.10 | SN04 | 6.35 | 0.25 | 0.18 | 2,224 | NA | 451.825 | 440.008 | 40.9208 | 0.607 | 22.29 | 2.00 |
| | 1524 | 38.10 | BZ10 | 2.54 | 0.15 | 0.20 | 31,138 | NA | 449.865 | 438.077 | 40.7453 | 0.614 | 22.29 | 2.00 |
| | 1524 | 38.10 | BN53 | 47.93 | 0.10 | 0.38 | 15,569 | 26,516 | 731.133 | 719.316 | 52.5623 | 0.812 | 33.76 | 2.00 |
| | 1524 | 38.10 | BNL53 | 47.93 | 0.10 | 0.05 | 15,569 | 26,516 | 731.133 | 719.316 | 52.5623 | 0.812 | 33.76 | 2.00 |
| | 1524 | 38.10 | BN02 | 12.70 | 0.10 | 0.38 | 40,257 | 50,719 | 544.986 | 533.198 | 41.5350 | 0.600 | 33.76 | 2.00 |
| | 1524 | 38.10 | BNL02 | 12.70 | 0.10 | 0.05 | 40,257 | 50,719 | 544.986 | 533.198 | 41.5350 | 0.600 | 33.76 | 2.00 |
| | 1524 | 38.10 | BN04 | 6.35 | 0.10 | 0.38 | 18,905 | 30,010 | 534.456 | 522.639 | 40.9208 | 0.607 | 33.76 | 2.00 |
| | 1524 | 38.10 | BNL04 | 6.35 | 0.10 | 0.05 | 18,905 | 30,010 | 534.456 | 522.639 | 40.9208 | 0.607 | 33.76 | 2.00 |
| | 1524 | 40.00 | BNM05 | 5.00 | 0.05 | 0.10 | 17,375 | 29,865 | 886.275 | 862.875 | 49.7250 | 1.062 | 33.76 | 2.00 |
| | 1524 | 40.00 | BNM10 | 10.00 | 0.05 | 0.10 | 24,372 | 33,253 | 886.275 | 862.875 | 49.7250 | 1.062 | 33.76 | 2.00 |
| | 1524 | 40.00 | BNM20 | 20.00 | 0.05 | 0.13 | 22,708 | 24,592 | 886.275 | 862.875 | 49.7250 | 1.062 | 33.76 | 2.00 |
| 1524 | 38.10 | BNH02 | 12.70 | 0.10 | 0.38 | 57,382 | 72,297 | 840.938 | 819.000 | 40.9500 | 1.062 | 33.76 | 2.00 | |
| 1524 | 38.10 | BNHL02 | 12.70 | 0.10 | 0.05 | 57,382 | 72,297 | 840.938 | 819.000 | 40.9500 | 1.062 | 33.76 | 2.00 | |
| 457 | 36.00 | RN05 | 5.00 | 0.01 | 0.03 | 58,001 | 97,741 | 757.575 | 737.100 | 36.5625 | 1.062 | 57.29 | 2.00 | |

Sold & Serviced By: **ELECTROMATIC**
 Toll Free Phone (877) 247-9889
 Toll Free Fax (877) 457-9098
 www.electromatic.com
 sales@electromatic.com

Contact Tolomatic for higher accuracy and lower backlash options.
 * For SN & BZ screws, maximum continuous dynamic thrust subject to Thrust x Velocity limitation.

GSA Electric Rod-Style Actuator

SIZE: **ALL**

units: **US standard**

SPECIFICATIONS

| SIZE | BEARING TYPE | GUIDE ROD in | MAX. STROKE in | SCREW DIA. in | SCREW TYPE | TPI turns/in | LEAD ACCURACY in/ft | BACKLASH in | MAX THRUST* lbf | DYNAMIC LOAD RATING** lbf | BASE ACTUATOR INERTIA | | INERTIA PER/in OF STROKE lb-in ² | BREAKAWAY TORQUE lb-in | MOVING PARTS WEIGHT | |
|------|--------------|-----------------|-------------------|------------------|------------|-----------------|------------------------|----------------|--------------------|------------------------------|-----------------------|--------------------|--|---------------------------|---------------------|----------|
| | | | | | | | | | | | In Line | Rev. Parallel | | | Base | Per Inch |
| | | | | | | | | | | | lb-in ² | lb-in ² | | | lb | lb |
| 12 | LINEAR | STANDARD 00.50 | 18 | 0.38 | SN01 | 1 | 0.010 | 0.007 | 70 | NA | 0.0324 | 0.0326 | 0.0040 | 2.938 | 1.21 | 0.14 |
| | | | 18 | 0.38 | SN02 | 2 | 0.006 | 0.007 | 70 | NA | 0.0095 | 0.0097 | 0.0014 | 1.500 | 1.21 | 0.14 |
| | | | 18 | 0.38 | SN05 | 5 | 0.006 | 0.007 | 70 | NA | 0.0030 | 0.0032 | 0.0006 | 0.563 | 1.21 | 0.14 |
| | | | 18 | 0.38 | BZ10 | 10 | 0.006 | 0.008 | 70 | NA | 0.0021 | 0.0023 | 0.0005 | 0.438 | 1.21 | 0.14 |
| | | | 18 | 0.38 | BN08 | 8 | 0.003 | 0.015 | 130 | 260 | 0.0023 | 0.0025 | 0.0006 | 0.500 | 1.29 | 0.14 |
| | | | 18 | 0.38 | BNL08 | 8 | 0.003 | 0.002 | 130 | 260 | 0.0023 | 0.0025 | 0.0006 | 0.500 | 1.29 | 0.14 |
| | COMPOSITE | STANDARD 00.50 | 18 | 0.38 | SN01 | 1 | 0.010 | 0.007 | 70 | NA | 0.0324 | 0.0326 | 0.0040 | 5.625 | 1.21 | 0.14 |
| | | | 18 | 0.38 | SN02 | 2 | 0.006 | 0.007 | 70 | NA | 0.0095 | 0.0097 | 0.0014 | 2.813 | 1.21 | 0.14 |
| | | | 18 | 0.38 | SN05 | 5 | 0.006 | 0.007 | 70 | NA | 0.0030 | 0.0032 | 0.0006 | 1.125 | 1.21 | 0.14 |
| | | | 18 | 0.38 | BZ10 | 10 | 0.006 | 0.008 | 70 | NA | 0.0021 | 0.0023 | 0.0005 | 0.813 | 1.21 | 0.14 |
| | | | 18 | 0.38 | BN08 | 8 | 0.003 | 0.015 | 130 | 260 | 0.0023 | 0.0025 | 0.0006 | 0.688 | 1.29 | 0.14 |
| | | | 18 | 0.38 | BNL08 | 8 | 0.003 | 0.002 | 130 | 260 | 0.0023 | 0.0025 | 0.0006 | 0.688 | 1.29 | 0.14 |
| | | OVERSIZED 00.63 | 18 | 0.38 | SN01 | 1 | 0.010 | 0.007 | 70 | NA | 0.0413 | 0.0415 | 0.0056 | 6.125 | 1.56 | 0.20 |
| | | | 18 | 0.38 | SN02 | 2 | 0.006 | 0.007 | 70 | NA | 0.0117 | 0.0119 | 0.0018 | 3.063 | 1.56 | 0.20 |
| | | | 18 | 0.38 | SN05 | 5 | 0.006 | 0.007 | 70 | NA | 0.0034 | 0.0036 | 0.0007 | 1.250 | 1.56 | 0.20 |
| | | | 18 | 0.38 | BZ10 | 10 | 0.006 | 0.008 | 70 | NA | 0.0022 | 0.0024 | 0.0006 | 0.938 | 1.56 | 0.20 |
| | | | 18 | 0.38 | BN08 | 8 | 0.003 | 0.015 | 130 | 260 | 0.0024 | 0.0026 | 0.0006 | 0.750 | 1.64 | 0.20 |
| | | | 18 | 0.38 | BNL08 | 8 | 0.003 | 0.002 | 130 | 260 | 0.0024 | 0.0026 | 0.0006 | 0.750 | 1.64 | 0.20 |
| 16 | LINEAR | STANDARD 00.63 | 24 | 0.38 | SN01 | 1 | 0.010 | 0.007 | 70 | NA | 0.0631 | 0.0633 | 0.0058 | 2.938 | 2.42 | 0.21 |
| | | | 24 | 0.38 | SN02 | 2 | 0.006 | 0.007 | 70 | NA | 0.0171 | 0.0173 | 0.0018 | 1.500 | 2.42 | 0.21 |
| | | | 24 | 0.38 | SN05 | 5 | 0.006 | 0.007 | 70 | NA | 0.0043 | 0.0045 | 0.0007 | 0.563 | 2.42 | 0.21 |
| | | | 24 | 0.38 | BZ10 | 10 | 0.006 | 0.008 | 70 | NA | 0.0024 | 0.0026 | 0.0006 | 0.438 | 2.42 | 0.21 |
| | | | 24 | 0.38 | BN08 | 8 | 0.003 | 0.015 | 130 | 260 | 0.0028 | 0.0030 | 0.0006 | 0.500 | 2.50 | 0.21 |
| | | | 24 | 0.38 | BNL08 | 8 | 0.003 | 0.002 | 130 | 260 | 0.0028 | 0.0030 | 0.0006 | 0.500 | 2.50 | 0.21 |
| | COMPOSITE | STANDARD 00.63 | 24 | 0.38 | SN01 | 1 | 0.010 | 0.007 | 70 | NA | 0.0631 | 0.0633 | 0.0058 | 6.125 | 2.42 | 0.21 |
| | | | 24 | 0.38 | SN02 | 2 | 0.006 | 0.007 | 70 | NA | 0.0171 | 0.0173 | 0.0018 | 3.063 | 2.42 | 0.21 |
| | | | 24 | 0.38 | SN05 | 5 | 0.006 | 0.007 | 70 | NA | 0.0043 | 0.0045 | 0.0007 | 1.250 | 2.42 | 0.21 |
| | | | 24 | 0.38 | BZ10 | 10 | 0.006 | 0.008 | 70 | NA | 0.0024 | 0.0026 | 0.0006 | 0.938 | 2.42 | 0.21 |
| | | | 24 | 0.38 | BN08 | 8 | 0.003 | 0.015 | 130 | 260 | 0.0028 | 0.0030 | 0.0006 | 0.688 | 2.50 | 0.21 |
| | | | 24 | 0.38 | BNL08 | 8 | 0.003 | 0.002 | 130 | 260 | 0.0028 | 0.0030 | 0.0006 | 0.688 | 2.50 | 0.21 |
| | | OVERSIZED 00.75 | 24 | 0.38 | SN01 | 1 | 0.010 | 0.007 | 70 | NA | 0.0763 | 0.0765 | 0.0078 | 6.625 | 2.94 | 0.29 |
| | | | 24 | 0.38 | SN02 | 2 | 0.006 | 0.007 | 70 | NA | 0.0204 | 0.0206 | 0.0023 | 3.313 | 2.94 | 0.29 |
| | | | 24 | 0.38 | SN05 | 5 | 0.006 | 0.007 | 70 | NA | 0.0048 | 0.0050 | 0.0008 | 1.313 | 2.94 | 0.29 |
| | | | 24 | 0.38 | BZ10 | 10 | 0.006 | 0.008 | 70 | NA | 0.0025 | 0.0027 | 0.0006 | 1.000 | 2.94 | 0.29 |
| | | | 24 | 0.38 | BN08 | 8 | 0.003 | 0.015 | 130 | 260 | 0.0030 | 0.0032 | 0.0006 | 0.750 | 3.02 | 0.29 |
| | | | 24 | 0.38 | BNL08 | 8 | 0.003 | 0.002 | 130 | 260 | 0.0030 | 0.0032 | 0.0006 | 0.750 | 3.02 | 0.29 |

Sold & Serviced By:

ELECTROMATE
 NEW ORLEANS, LOUISIANA
 Ball Nut
 Ball Nut Series
 Low Backlash Ball Nut
 Toll Free Phone (877) 611-1111
 Toll Free Fax (877) SERV099
 www.electromate.com
 sales@electromate.com

| SCREW CODE | DESCRIPTION |
|------------|-----------------|
| BNM | Ball Nut Metric |
| BZ | Bronze Nut |
| SN | Solid Nut |



Contact Tolomatic for higher accuracy and lower backlash options.
 * For SN & BZ screws, maximum continuous dynamic thrust subject to Thrust x Velocity limitation.
 ** For BN & BNL screws, dynamic load rating reflects 90% reliability for 1 million revolutions.

GSA Electric Rod-Style Actuator

SIZE: ALL

units: US standard

SPECIFICATIONS

| SIZE | BEARING TYPE | GUIDE ROD | MAX. STROKE | SCREW DIA. | SCREW TYPE | TPI | LEAD ACCURACY | BACKLASH | MAX THRUST* | DYNAMIC LOAD RATING** | BASE ACTUATOR INERTIA | | INERTIA PER/in OF STROKE | BREAKAWAY TORQUE | MOVING PARTS WEIGHT | | |
|------|--------------|----------------|----------------|------------|------------|--------|---------------|----------|-------------|-----------------------|-----------------------|--------------------|--------------------------|------------------|---------------------|----------|------|
| | | | | | | | | | | | In Line | Rev. Parallel | | | Base | Per Inch | |
| | | | | | | | | | | | lb-in ² | lb-in ² | | | lb | lb | |
| 24 | LINEAR | STANDARD Ø0.75 | 30 | 0.625 | SN02 | 2 | 0.0050 | 0.0070 | 200 | NA | 0.0399 | 0.0404 | 0.0060 | 1.875 | 4.49 | 0.33 | |
| | | | 30 | 0.625 | SN04 | 4 | 0.0100 | 0.0070 | 200 | NA | 0.0260 | 0.0265 | 0.0047 | 1.125 | 4.49 | 0.33 | |
| | | | 30 | 0.625 | SN08 | 8 | 0.0100 | 0.0070 | 200 | NA | 0.0225 | 0.0230 | 0.0043 | 1.563 | 4.49 | 0.33 | |
| | | | 30 | 0.625 | BZ10 | 10 | 0.0060 | 0.0080 | 850 | NA | 0.0220 | 0.0225 | 0.0043 | 2.000 | 4.49 | 0.33 | |
| | | | 30 | 0.625 | BN05 | 5 | 0.0030 | 0.0150 | 825 | 1,411 | 0.0244 | 0.0249 | 0.0045 | 1.563 | 4.75 | 0.33 | |
| | | | 30 | 0.625 | BNL05 | 5 | 0.0030 | 0.0020 | 825 | 1,411 | 0.0244 | 0.0249 | 0.0045 | 1.563 | 4.75 | 0.33 | |
| | | | 30 | 0.500 | BN02 | 2 | 0.0030 | 0.0150 | 850 | 1,071 | 0.0441 | 0.0446 | 0.0039 | 1.56 | 4.75 | 0.330 | |
| | | | 30 | 0.500 | BNL02 | 2 | 0.0030 | 0.0020 | 850 | 1,071 | 0.0441 | 0.0446 | 0.0039 | 1.56 | 4.75 | 0.330 | |
| | | | 30 | 0.625 | SN02 | 2 | 0.0050 | 0.0070 | 200 | NA | 0.0497 | 0.0502 | 0.0063 | 3.438 | 4.49 | 0.33 | |
| | | | 30 | 0.625 | SN04 | 4 | 0.0100 | 0.0070 | 200 | NA | 0.0284 | 0.0289 | 0.0047 | 2.188 | 4.49 | 0.33 | |
| | | | 30 | 0.625 | SN08 | 8 | 0.0100 | 0.0070 | 200 | NA | 0.0231 | 0.0236 | 0.0043 | 1.563 | 4.49 | 0.33 | |
| | | | 30 | 0.625 | BZ10 | 10 | 0.0060 | 0.0080 | 850 | NA | 0.0224 | 0.0229 | 0.0043 | 2.000 | 4.49 | 0.33 | |
| | | | 30 | 0.625 | BN05 | 5 | 0.0030 | 0.0150 | 825 | 1,411 | 0.0261 | 0.0266 | 0.0045 | 1.563 | 4.75 | 0.33 | |
| | | | 30 | 0.625 | BNL05 | 5 | 0.0030 | 0.0020 | 825 | 1,411 | 0.0261 | 0.0266 | 0.0045 | 1.563 | 4.75 | 0.33 | |
| | 30 | 0.500 | BN02 | 2 | 0.0030 | 0.0150 | 850 | 1,071 | 0.0441 | 0.0446 | 0.0039 | 1.56 | 4.75 | 0.330 | | | |
| | 30 | 0.500 | BNL02 | 2 | 0.0030 | 0.0020 | 850 | 1,071 | 0.0441 | 0.0446 | 0.0039 | 1.56 | 4.75 | 0.330 | | | |
| | 30 | 0.625 | SN02 | 2 | 0.0050 | 0.0070 | 200 | NA | 0.0597 | 0.0602 | 0.0076 | 3.875 | 6.06 | 0.53 | | | |
| | 30 | 0.625 | SN04 | 4 | 0.0100 | 0.0070 | 200 | NA | 0.0309 | 0.0314 | 0.0050 | 2.813 | 6.06 | 0.53 | | | |
| | 30 | 0.625 | SN08 | 8 | 0.0100 | 0.0070 | 200 | NA | 0.0237 | 0.0242 | 0.0044 | 1.875 | 6.06 | 0.53 | | | |
| | 30 | 0.625 | BZ10 | 10 | 0.0060 | 0.0080 | 850 | NA | 0.0228 | 0.0233 | 0.0043 | 2.188 | 6.06 | 0.53 | | | |
| | 30 | 0.625 | BN05 | 5 | 0.0030 | 0.0150 | 825 | 1,411 | 0.0277 | 0.0282 | 0.0047 | 1.875 | 6.32 | 0.53 | | | |
| | 30 | 0.625 | BNL05 | 5 | 0.0030 | 0.0020 | 825 | 1,411 | 0.0277 | 0.0282 | 0.0047 | 1.875 | 6.32 | 0.53 | | | |
| | 30 | 0.500 | BN02 | 2 | 0.0030 | 0.0150 | 850 | 1,071 | 0.0567 | 0.0572 | 0.0053 | 1.88 | 6.32 | 0.530 | | | |
| | 30 | 0.500 | BNL02 | 2 | 0.0030 | 0.0020 | 850 | 1,071 | 0.0567 | 0.0572 | 0.0053 | 1.88 | 6.32 | 0.530 | | | |
| | 32 | LINEAR | STANDARD Ø1.00 | 36 | 0.75 | SN01 | 1 | 0.0050 | 0.0070 | 188 | NA | 0.2903 | 0.2946 | 0.0239 | 4.375 | 9.03 | 0.60 |
| | | | | 36 | 0.75 | SN02 | 2 | 0.0050 | 0.0070 | 300 | NA | 0.1188 | 0.1231 | 0.0125 | 3.750 | 9.03 | 0.60 |
| | | | | 36 | 0.75 | BZ10 | 10 | 0.0060 | 0.0080 | 785 | NA | 0.0639 | 0.0682 | 0.0088 | 2.000 | 9.03 | 0.60 |
| | | | | 36 | 0.75 | BN02 | 2 | 0.0040 | 0.0150 | 534 | 3,364 | 0.1218 | 0.1261 | 0.0125 | 3.125 | 9.51 | 0.60 |
| 36 | | | | 0.75 | BNL02 | 2 | 0.0040 | 0.0020 | 534 | 3,364 | 0.1218 | 0.1261 | 0.0125 | 3.125 | 9.51 | 0.60 | |
| 36 | | | | 0.75 | BN05 | 5 | 0.0030 | 0.0150 | 950 | 1,624 | 0.0712 | 0.0755 | 0.0093 | 1.875 | 9.51 | 0.60 | |
| 36 | | | | 0.75 | BNL05 | 5 | 0.0030 | 0.0020 | 950 | 1,624 | 0.0712 | 0.0755 | 0.0093 | 1.875 | 9.51 | 0.60 | |
| 36 | | | | 0.787 | BNM20 | 1.27 | 0.0020 | 0.0050 | 339 | 2,560 | 0.0712 | 0.0755 | 0.0093 | 1.875 | 9.51 | 0.60 | |
| 36 | | | | 0.75 | SN01 | 1 | 0.0050 | 0.0070 | 188 | NA | 0.2903 | 0.2946 | 0.0239 | 8.688 | 9.03 | 0.60 | |
| 36 | | | | 0.75 | SN02 | 2 | 0.0050 | 0.0070 | 300 | NA | 0.1188 | 0.1231 | 0.0125 | 4.375 | 9.03 | 0.60 | |
| 36 | | | | 0.75 | BZ10 | 10 | 0.0060 | 0.0080 | 785 | NA | 0.0639 | 0.0682 | 0.0088 | 2.813 | 9.03 | 0.60 | |
| 36 | | | | 0.75 | BN02 | 2 | 0.0040 | 0.0150 | 534 | 3,364 | 0.1218 | 0.1261 | 0.0125 | 3.438 | 9.51 | 0.60 | |
| 36 | | | | 0.75 | BNL02 | 2 | 0.0040 | 0.0020 | 534 | 3,364 | 0.1218 | 0.1261 | 0.0125 | 3.438 | 9.51 | 0.60 | |
| 36 | | | | 0.75 | BN05 | 5 | 0.0030 | 0.0150 | 950 | 1,624 | 0.0712 | 0.0755 | 0.0093 | 2.188 | 9.51 | 0.60 | |
| 36 | | 0.75 | BNL05 | 5 | 0.0030 | 0.0020 | 950 | 1,624 | 0.0712 | 0.0755 | 0.0093 | 2.188 | 9.51 | 0.60 | | | |
| 36 | | 0.75 | BNM20 | 1.27 | 0.0020 | 0.0050 | 339 | 2,560 | 0.0712 | 0.0755 | 0.0093 | 2.188 | 9.51 | 0.60 | | | |
| 36 | | 0.75 | SN01 | 1 | 0.0050 | 0.0070 | 188 | NA | 0.3504 | 0.3547 | 0.0305 | 10.000 | 11.40 | 0.86 | | | |
| 36 | | 0.75 | SN02 | 2 | 0.0050 | 0.0070 | 300 | NA | 0.1338 | 0.1381 | 0.0141 | 5.625 | 11.40 | 0.86 | | | |
| 36 | | 0.75 | BZ10 | 10 | 0.0060 | 0.0080 | 785 | NA | 0.0645 | 0.0688 | 0.0089 | 3.438 | 11.40 | 0.86 | | | |
| 36 | | 0.75 | BN02 | 2 | 0.0040 | 0.0150 | 534 | 3,364 | 0.1368 | 0.1411 | 0.0141 | 4.063 | 11.88 | 0.86 | | | |
| 36 | | 0.75 | BNL02 | 2 | 0.0040 | 0.0020 | 534 | 3,364 | 0.1368 | 0.1411 | 0.0141 | 4.063 | 11.88 | 0.86 | | | |
| 36 | | 0.75 | BN05 | 5 | 0.0030 | 0.0150 | 950 | 1,624 | 0.0736 | 0.0779 | 0.0096 | 2.500 | 11.88 | 0.86 | | | |
| 36 | | 0.75 | BNL05 | 5 | 0.0030 | 0.0020 | 950 | 1,624 | 0.0736 | 0.0779 | 0.0096 | 2.500 | 11.88 | 0.86 | | | |
| 36 | | 0.75 | BNM20 | 1.27 | 0.0020 | 0.0050 | 339 | 2,560 | 0.0736 | 0.0779 | 0.0096 | 2.500 | 11.88 | 0.86 | | | |

Sold & Serviced By:



Toll Free Phone (877) SERV098

Toll Free 800-222-2222

www.electromate.com

sales@electromate.com

| SCREW CODE | DESCRIPTION |
|------------|-----------------|
| BNM | Ball Nut Metric |
| BZ | Bronze Nut |
| SN | Solid Nut |



Contact Tolomatic for higher accuracy and lower backlash options.

* For SN & BZ screws, maximum continuous dynamic thrust subject to Thrust x Velocity limitation.

** For BN & BNL screws, dynamic load rating reflects 90% reliability for 1 million revolutions.

GSM Electric Rod-Style Actuator

SIZE: **ALL**

units: **metric****

SPECIFICATIONS

** GSM metric actuators use the same leadscrew as the GSA inch actuators. Threaded mounting and dowel pin holes are metric.

| SIZE | BEARING TYPE | GUIDE ROD in | SCREW DIA. mm | SCREW TYPE | LEAD mm/rev | LEAD ACCURACY mm/300 | BACKLASH mm | MAX THRUST* N | DYNAMIC THRUST RATING** | BASE ACTUATOR INERTIA | | INERTIA PER/in OF STROKE kg-m ² x10 ⁻⁶ | BREAKAWAY TORQUE N-m | MOVING PARTS WEIGHT | |
|------|--------------|-----------------|------------------|------------|----------------|-------------------------|----------------|------------------|-------------------------|-------------------------------------|-------------------------------------|---|-------------------------|---------------------|----------|
| | | | | | | | | | | In Line | Rev. Parallel | | | Base | Per Inch |
| | | | | | | | | | | kg-m ² x10 ⁻⁶ | kg-m ² x10 ⁻⁶ | | | Kg | Kg |
| 12 | LINEAR | STANDARD Ø0.50 | 9.5 | SN01 | 25.40 | 0.25 | 0.18 | 311 | NA | 9.492 | 9.550 | 1.184 | 0.332 | 0.549 | 0.063 |
| | | | | SN02 | 12.70 | 0.15 | 0.18 | 311 | NA | 2.768 | 2.826 | 0.406 | 0.169 | 0.549 | 0.063 |
| | | | | SN05 | 5.08 | 0.15 | 0.18 | 311 | NA | 0.885 | 0.944 | 0.188 | 0.064 | 0.549 | 0.063 |
| | | | | BZ10 | 2.54 | 0.15 | 0.20 | 311 | NA | 0.616 | 0.675 | 0.157 | 0.049 | 0.549 | 0.063 |
| | | | | BN08 | 3.18 | 0.08 | 0.38 | 578 | 1,157 | 0.676 | 0.734 | 0.163 | 0.056 | 0.585 | 0.063 |
| | | | | BNL08 | 3.18 | 0.08 | 0.05 | 578 | 1,157 | 0.676 | 0.734 | 0.163 | 0.056 | 0.585 | 0.063 |
| | COMPOSITE | STANDARD Ø0.50 | 9.5 | SN01 | 25.40 | 0.25 | 0.18 | 311 | NA | 9.492 | 9.550 | 1.184 | 0.636 | 0.549 | 0.063 |
| | | | | SN02 | 12.70 | 0.15 | 0.18 | 311 | NA | 2.798 | 2.826 | 0.406 | 0.318 | 0.549 | 0.063 |
| | | | | SN05 | 5.08 | 0.15 | 0.18 | 311 | NA | 0.885 | 0.944 | 0.188 | 0.127 | 0.549 | 0.063 |
| | | | | BZ10 | 2.54 | 0.15 | 0.20 | 311 | NA | 0.616 | 0.675 | 0.157 | 0.092 | 0.549 | 0.063 |
| | | | | BN08 | 3.18 | 0.08 | 0.38 | 578 | 1,157 | 0.676 | 0.734 | 0.163 | 0.078 | 0.585 | 0.063 |
| | | | | BNL08 | 3.18 | 0.08 | 0.05 | 578 | 1,157 | 0.676 | 0.734 | 0.163 | 0.078 | 0.585 | 0.063 |
| | | OVERSIZED Ø0.63 | 9.5 | SN01 | 25.40 | 0.25 | 0.18 | 311 | NA | 12.085 | 12.143 | 1.628 | 0.692 | 0.707 | 0.09 |
| | | | | SN02 | 12.70 | 0.15 | 0.18 | 311 | NA | 3.416 | 3.475 | 0.517 | 0.346 | 0.707 | 0.09 |
| | | | | SN05 | 5.08 | 0.15 | 0.18 | 311 | NA | 0.989 | 1.047 | 0.206 | 0.141 | 0.707 | 0.09 |
| | | | | BZ10 | 2.54 | 0.15 | 0.20 | 311 | NA | 0.642 | 0.701 | 0.161 | 0.106 | 0.707 | 0.09 |
| | | | | BN08 | 3.18 | 0.08 | 0.38 | 578 | 1,157 | 0.716 | 0.775 | 0.169 | 0.085 | 0.744 | 0.09 |
| | | | | BNL08 | 3.18 | 0.08 | 0.05 | 578 | 1,157 | 0.716 | 0.775 | 0.169 | 0.085 | 0.744 | 0.09 |
| 16 | LINEAR | STANDARD Ø0.63 | 9.5 | SN01 | 25.40 | 0.25 | 0.18 | 311 | NA | 18.457 | 18.515 | 1.702 | 0.332 | 1.10 | 0.095 |
| | | | | SN02 | 12.70 | 0.15 | 0.18 | 311 | NA | 5.009 | 5.068 | 0.535 | 0.169 | 1.10 | 0.095 |
| | | | | SN05 | 5.08 | 0.15 | 0.18 | 311 | NA | 1.245 | 1.302 | 0.209 | 0.064 | 1.10 | 0.095 |
| | | | | BZ10 | 2.54 | 0.15 | 0.20 | 311 | NA | 0.706 | 0.764 | 0.162 | 0.049 | 1.10 | 0.095 |
| | | | | BN08 | 3.18 | 0.08 | 0.38 | 578 | 1,157 | 0.816 | 0.874 | 0.171 | 0.056 | 1.13 | 0.095 |
| | | | | BNL08 | 3.18 | 0.08 | 0.05 | 578 | 1,157 | 0.816 | 0.874 | 0.171 | 0.056 | 1.13 | 0.095 |
| | COMPOSITE | STANDARD Ø0.63 | 9.5 | SN01 | 25.40 | 0.25 | 0.18 | 311 | NA | 18.457 | 18.515 | 1.702 | 0.692 | 1.10 | 0.095 |
| | | | | SN02 | 12.70 | 0.15 | 0.18 | 311 | NA | 5.009 | 5.068 | 0.535 | 0.346 | 1.10 | 0.095 |
| | | | | SN05 | 5.08 | 0.15 | 0.18 | 311 | NA | 1.244 | 1.302 | 0.209 | 0.141 | 1.10 | 0.095 |
| | | | | BZ10 | 2.54 | 0.15 | 0.20 | 311 | NA | 0.706 | 0.764 | 0.162 | 0.106 | 1.10 | 0.095 |
| | | | | BN08 | 3.18 | 0.08 | 0.38 | 578 | 1,157 | 0.816 | 0.874 | 0.171 | 0.078 | 1.13 | 0.095 |
| | | | | BNL08 | 3.18 | 0.08 | 0.05 | 578 | 1,157 | 0.816 | 0.874 | 0.171 | 0.078 | 1.13 | 0.095 |
| | | OVERSIZED Ø0.75 | 9.5 | SN01 | 25.40 | 0.25 | 0.18 | 311 | NA | 22.309 | 22.368 | 2.295 | 0.749 | 1.33 | 0.132 |
| | | | | SN02 | 12.70 | 0.15 | 0.18 | 311 | NA | 5.972 | 6.031 | 0.683 | 0.374 | 1.33 | 0.132 |
| | | | | SN05 | 5.08 | 0.15 | 0.18 | 311 | NA | 1.398 | 1.456 | 0.232 | 0.148 | 1.33 | 0.132 |
| | | | | BZ10 | 2.54 | 0.15 | 0.20 | 311 | NA | 0.744 | 0.803 | 0.168 | 0.113 | 1.33 | 0.132 |
| | | | | BN08 | 3.18 | 0.08 | 0.38 | 578 | 1,157 | 0.876 | 0.935 | 0.180 | 0.085 | 1.37 | 0.132 |
| | | | | BNL08 | 3.18 | 0.08 | 0.05 | 578 | 1,157 | 0.876 | 0.935 | 0.180 | 0.085 | 1.37 | 0.132 |

Sold & Serviced By:



Toll Free Phone (877) SERV098

Toll Free Fax (877) SERV099

www.electromate.com

sales@electromate.com

| SCREW CODE | DESCRIPTION |
|------------|-----------------------|
| BN | Ball Nut |
| BZ | Bronze Nut |
| BNL | Low-Backlash Ball Nut |

| SCREW CODE | DESCRIPTION |
|------------|-----------------|
| BNM | Ball Nut Metric |
| BZ | Bronze Nut |
| SN | Solid Nut |



Contact Tolomatic for higher accuracy and lower backlash options.

* For SN & BZ screws, maximum continuous dynamic thrust subject to Thrust x Velocity limitation.

** For BN & BNL screws, dynamic load rating reflects 90% reliability for 1 million revolutions.

GSM Electric Rod-Style Actuator

SIZE: ALL units: metric**

SPECIFICATIONS

** GSM metric actuators use the same leadscrew as the GSA inch actuators. Threaded mounting and dowel pin holes are metric.

| SIZE | BEARING TYPE | GUIDE ROD in | SCREW DIA. mm | SCREW TYPE | LEAD mm/rev | LEAD ACCURACY mm/300 | BACKLASH mm | MAX THRUST* N | DYNAMIC THRUST RATING** | BASE ACTUATOR INERTIA | | INERTIA PER/in OF STROKE kg-m ² x10 ⁻⁶ | BREAKAWAY TORQUE N-m | MOVING PARTS WEIGHT | | | |
|-------|-----------------|-----------------|------------------|----------------|----------------|-------------------------|----------------|------------------|-------------------------|-------------------------------------|-------------------------------------|---|-------------------------|---------------------|----------|------|------|
| | | | | | | | | | | In Line | Rev. Parallel | | | Base | Per Inch | | |
| | | | | | | | | | | kg-m ² x10 ⁻⁶ | kg-m ² x10 ⁻⁶ | | | Kg | Kg | | |
| 24 | LINEAR | STANDARD Ø0.75 | 15.88 | SN02 | 12.70 | 0.13 | 0.18 | 890 | NA | 11.676 | 11.822 | 1.764 | 0.212 | 2.04 | 0.15 | | |
| | | | | SN04 | 6.35 | 0.25 | 0.18 | 890 | NA | 7.592 | 7.738 | 1.361 | 0.127 | 2.04 | 0.15 | | |
| | | | | SN08 | 3.18 | 0.25 | 0.18 | 890 | NA | 6.571 | 6.717 | 1.260 | 0.177 | 2.04 | 0.15 | | |
| | | | | BZ10 | 2.54 | 0.15 | 0.20 | 3,781 | NA | 6.448 | 6.594 | 1.248 | 0.226 | 2.04 | 0.15 | | |
| | | | | BN05 | 5.08 | 0.08 | 0.38 | 3,670 | 6,275 | 7.125 | 7.272 | 1.313 | 0.177 | 2.15 | 0.15 | | |
| | | | | BNL05 | 5.08 | 0.08 | 0.05 | 3,670 | 6,275 | 7.125 | 7.272 | 1.313 | 0.177 | 2.15 | 0.15 | | |
| | | 12.7 | BN02 | 12.70 | 0.08 | 0.38 | 3,781 | 4,764 | 12.905 | 13.051 | 1.144 | 0.176 | 2.15 | 0.15 | | | |
| | | | BNL02 | 12.70 | 0.08 | 0.05 | 3,781 | 4,764 | 12.905 | 13.051 | 1.144 | 0.176 | 2.15 | 0.15 | | | |
| | | | COMPOSITE | STANDARD Ø0.75 | 15.88 | SN02 | 12.70 | 0.13 | 0.18 | 890 | NA | 14.547 | 14.693 | 1.838 | 0.388 | 2.04 | 0.15 |
| | | | | | | SN04 | 6.35 | 0.25 | 0.18 | 890 | NA | 8.309 | 8.456 | 1.380 | 0.247 | 2.04 | 0.15 |
| | | | | | | SN08 | 3.18 | 0.25 | 0.18 | 890 | NA | 6.750 | 6.896 | 1.265 | 0.177 | 2.04 | 0.15 |
| | | | | | | BZ10 | 2.54 | 0.15 | 0.20 | 3,781 | NA | 6.563 | 6.709 | 1.251 | 0.226 | 2.04 | 0.15 |
| | BN05 | 5.08 | | | | 0.08 | 0.38 | 3,670 | 6,275 | 7.638 | 7.784 | 1.325 | 0.177 | 2.15 | 0.15 | | |
| | BNL05 | 5.08 | | | | 0.08 | 0.05 | 3,670 | 6,275 | 7.638 | 7.784 | 1.325 | 0.177 | 2.15 | 0.15 | | |
| | 12.7 | BN02 | 12.70 | 0.08 | 0.38 | 3,781 | 4,764 | 12.905 | 13.051 | 1.144 | 0.176 | 2.15 | 0.15 | | | | |
| | | BNL02 | 12.70 | 0.08 | 0.05 | 3,781 | 4,764 | 12.905 | 13.051 | 1.144 | 0.176 | 2.15 | 0.15 | | | | |
| | | OVERSIZED Ø1.00 | 15.88 | SN02 | 12.70 | 0.13 | 0.18 | 890 | NA | 17.455 | 17.601 | 2.209 | 0.438 | 2.75 | 0.24 | | |
| | | | | SN04 | 6.35 | 0.25 | 0.18 | 890 | NA | 9.037 | 9.183 | 1.472 | 0.318 | 2.75 | 0.24 | | |
| | | | | SN08 | 3.18 | 0.25 | 0.18 | 890 | NA | 6.932 | 7.078 | 1.288 | 0.212 | 2.75 | 0.24 | | |
| | | | | BZ10 | 2.54 | 0.15 | 0.20 | 3,781 | NA | 6.679 | 6.826 | 1.266 | 0.247 | 2.75 | 0.24 | | |
| | BN05 | | | 5.08 | 0.08 | 0.38 | 3,670 | 6,275 | 8.103 | 8.230 | 1.384 | 0.212 | 2.87 | 0.24 | | | |
| | BNL05 | | | 5.08 | 0.08 | 0.05 | 3,670 | 6,275 | 8.103 | 8.230 | 1.384 | 0.212 | 2.87 | 0.24 | | | |
| | 12.7 | BN02 | 12.70 | 0.08 | 0.38 | 3,781 | 4,764 | 16.588 | 16.734 | 1.541 | 0.212 | 2.87 | 0.24 | | | | |
| | | BNL02 | 12.70 | 0.08 | 0.05 | 3,781 | 4,764 | 16.588 | 16.734 | 1.541 | 0.212 | 2.87 | 0.24 | | | | |
| 32 | | LINEAR | STANDARD Ø1.00 | 19.1 | SN01 | 25.40 | 0.13 | 0.18 | 836 | NA | 84.922 | 86.180 | 6.987 | 0.494 | 4.10 | 0.27 | |
| | | | | | SN02 | 12.70 | 0.13 | 0.18 | 1,334 | NA | 34.744 | 36.002 | 3.653 | 0.424 | 4.10 | 0.27 | |
| | | | | | BZ10 | 2.54 | 0.15 | 0.20 | 3,492 | NA | 18.687 | 19.945 | 2.586 | 0.226 | 4.10 | 0.27 | |
| | | | | | BN02 | 12.70 | 0.10 | 0.38 | 2,375 | 14,964 | 35.633 | 36.891 | 3.653 | 0.353 | 4.31 | 0.27 | |
| | BNL02 | | | | 12.70 | 0.10 | 0.05 | 2,375 | 14,964 | 35.633 | 36.891 | 3.653 | 0.353 | 4.31 | 0.27 | | |
| | BN05 | | | | 5.08 | 0.08 | 0.38 | 4,226 | 7,226 | 20.836 | 22.094 | 2.720 | 0.212 | 4.31 | 0.27 | | |
| | 20.0 | BNL05 | 5.08 | 0.08 | 0.05 | 4,226 | 7,226 | 20.836 | 22.094 | 2.720 | 0.212 | 4.31 | 0.27 | | | | |
| | | BNM20 | 20.00 | 0.05 | 0.13 | 1,508 | 11,388 | 20.836 | 22.094 | 2.720 | 0.212 | 4.31 | 0.27 | | | | |
| | | COMPOSITE | STANDARD Ø1.00 | 19.1 | SN01 | 25.40 | 0.13 | 0.18 | 836 | NA | 84.922 | 86.180 | 6.987 | 0.982 | 4.10 | 0.27 | |
| | | | | | SN02 | 12.70 | 0.13 | 0.18 | 1,334 | NA | 34.744 | 36.002 | 3.653 | 0.494 | 4.10 | 0.27 | |
| | | | | | BZ10 | 2.54 | 0.15 | 0.20 | 3,492 | NA | 18.687 | 19.945 | 2.586 | 0.318 | 4.10 | 0.27 | |
| | | | | | BN02 | 12.70 | 0.10 | 0.38 | 2,375 | 14,964 | 35.633 | 36.891 | 3.653 | 0.388 | 4.31 | 0.27 | |
| BNL02 | 12.70 | | | | 0.10 | 0.05 | 2,375 | 14,964 | 35.633 | 36.891 | 3.653 | 0.388 | 4.31 | 0.27 | | | |
| BN05 | 5.08 | | | | 0.08 | 0.38 | 4,226 | 7,226 | 20.836 | 22.094 | 2.720 | 0.247 | 4.31 | 0.27 | | | |
| 19.1 | BNL05 | 5.08 | 0.08 | 0.05 | 4,226 | 7,226 | 20.836 | 22.094 | 2.720 | 0.247 | 4.31 | 0.27 | | | | | |
| | BNM20 | 20.00 | 0.05 | 0.13 | 1,508 | 11,388 | 20.836 | 22.094 | 2.720 | 0.212 | 4.31 | 0.27 | | | | | |
| | OVERSIZED Ø1.25 | 19.1 | SN01 | 25.40 | 0.13 | 0.18 | 836 | NA | 102.482 | 103.740 | 8.914 | 1.130 | 5.17 | 0.39 | | | |
| | | | SN02 | 12.70 | 0.13 | 0.18 | 1,334 | NA | 39.134 | 40.392 | 4.135 | 0.636 | 5.17 | 0.39 | | | |
| | | | BZ10 | 2.54 | 0.15 | 0.20 | 3,492 | NA | 18.863 | 20.120 | 2.606 | 0.388 | 5.17 | 0.39 | | | |
| | | | BN02 | 12.70 | 0.10 | 0.38 | 2,375 | 14,964 | 40.023 | 41.281 | 4.135 | 0.459 | 5.39 | 0.39 | | | |
| BNL02 | | | 12.70 | 0.10 | 0.05 | 2,375 | 14,964 | 40.023 | 41.281 | 4.135 | 0.459 | 5.39 | 0.39 | | | | |
| BN05 | | | 5.08 | 0.08 | 0.38 | 4,226 | 7,226 | 21.539 | 22.797 | 2.797 | 0.282 | 5.39 | 0.39 | | | | |
| 20.0 | BNL05 | 5.08 | 0.08 | 0.05 | 4,226 | 7,226 | 21.539 | 22.797 | 2.797 | 0.282 | 5.39 | 0.39 | | | | | |
| | BNM20 | 20.00 | 0.05 | 0.13 | 1,508 | 11,388 | 21.539 | 22.797 | 2.797 | 0.282 | 5.39 | 0.39 | | | | | |

Sold & Serviced By:



Toll Free Phone (877) SERV098
Toll Free Fax (877) SERV099

| SCREW CODE | DESCRIPTION |
|------------|-----------------------|
| BNM | Ball Nut Metric |
| BZ | Bronze Nut |
| SN | Solid Nut |
| BNL | Low-Backlash Ball Nut |



Contact Tolomatic for higher accuracy and lower backlash options.

* For SN & BZ screws, maximum continuous dynamic thrust subject to Thrust x Velocity limitation.

** For BN & BNL screws, dynamic load rating reflects 90% reliability for 1 million revolutions.

RSA & GSA Electric Rod-Style Actuator

SIZE: ALL

SPECIFICATIONS

ACTUATOR SPECIFICATIONS

| RSA (M) SIZE | | | 12 | 16 | 24 | | 32ST | 32HT | | 50ST | 50HT | | 64ST | 64HT | | |
|--------------|--------------------|----------|--------|--------|------------|------------|--------|------------|------------|--------|------------|------------|--------|------------|------------|-------|
| | | | | | All Others | Roller Nut | | All Others | Roller Nut | | All Others | Roller Nut | | All Others | Roller Nut | |
| WEIGHT | BASE MODEL | IN-LINE | lb | 1.73 | 3.73 | 3.98 | 5.81 | 6.11 | 12.76 | 17.29 | 14.21 | 20.58 | 22.08 | 23.01 | 38.10 | 40.06 |
| | | | kg | 0.78 | 1.68 | 1.79 | 2.61 | 2.75 | 5.79 | 7.84 | 6.39 | 9.33 | 10.01 | 10.35 | 17.28 | 18.17 |
| | REVERSE PARALLEL | lb | 2.40 | 4.00 | 6.25 | 7.64 | 10.40 | 12.01 | 20.36 | 19.66 | 25.32 | 26.82 | 29.69 | 44.43 | 46.39 | |
| | | kg | 1.08 | 1.80 | 2.81 | 3.44 | 4.68 | 5.45 | 9.17 | 8.85 | 11.40 | 12.08 | 13.36 | 20.15 | 21.04 | |
| | PER UNIT OF STROKE | lb/in | 0.128 | 0.300 | 0.330 | 0.321 | 0.460 | 0.460 | 0.473 | 0.860 | 0.860 | 0.950 | 1.380 | 1.380 | 1.325 | |
| | | kg/mm | 0.0023 | 0.0053 | 0.0058 | 0.0057 | 0.0081 | 0.0081 | 0.0084 | 0.0152 | 0.0152 | 0.0168 | 0.0244 | 0.0244 | 0.0234 | |
| MAX. STROKE | in | 18.0 | 18.0 | 24.0 | 18.0 | 36.0 | 36.0 | 18.0 | 48.0 | 48.0 | 18.0 | 60.0 | 60.0 | 18.0 | | |
| | mm | 457.2 | 457.2 | 609.6 | 457.2 | 914.4 | 914.4 | 457.2 | 1219.2 | 1219.2 | 457.2 | 1524 | 1524 | 457.2 | | |
| TEMP. RANGE* | °F | 40 - 130 | | | 50-122 | 40 - 130 | | 50-122 | 40 - 130 | | 50-122 | 40 - 130 | | 50-122 | | |
| | °C | 4 - 54 | | | 10-50 | 4 - 54 | | 10-50 | 4 - 54 | | 10-50 | 4 - 54 | | 10-50 | | |

Gasket Kit providing ingress protection against dust and splashing water available upon request

| GSA(M) SIZE | | | 12 | | | | 16 | | 24 | | 32 | | |
|--------------|--------------------|----------|----------|-------|----------|-------|-------|-------|-------|-------|-------|-------|-------|
| | | | 17 frame | | 23 frame | | | | | | | | |
| Guide Rod | | | STD | OVR | STD | OVR | STD | OVR | STD | OVR | STD | OVR | |
| WEIGHT | BASE MODEL | IN-LINE | lb | 3.65 | 4.44 | 3.68 | 4.47 | 7.25 | 7.54 | 16.48 | 17.35 | 27.34 | 28.65 |
| | | | kg | 1.65 | 2.01 | 1.67 | 2.03 | 3.29 | 3.42 | 7.48 | 7.87 | 12.40 | 13.00 |
| | REVERSE PARALLEL | lb | 3.92 | 4.72 | 4.05 | 4.85 | 7.59 | 7.88 | 17.09 | 17.96 | 28.81 | 30.12 | |
| | | kg | 1.78 | 2.14 | 1.84 | 2.20 | 3.44 | 3.57 | 7.75 | 8.15 | 13.07 | 13.66 | |
| | PER UNIT OF STROKE | lb/in | 0.21 | 0.27 | 0.21 | 0.27 | 0.30 | 0.38 | 0.54 | 0.74 | 0.93 | 1.19 | |
| | | kg/mm | 0.004 | 0.005 | 0.004 | 0.005 | 0.005 | 0.007 | 0.010 | 0.013 | 0.017 | 0.021 | |
| MAX. STROKE | in | 18 | | | | 24 | | 30 | | 36 | | | |
| | mm | 457 | | | | 609 | | 762 | | 914 | | | |
| TEMP. RANGE* | °F | 40 - 130 | | | | | | | | | | | |
| | °C | 4 - 54 | | | | | | | | | | | |

Gasket Kit providing ingress protection against dust and splashing water available upon request



*** Heat generated by the motor and drive should be taken into consideration as well as linear velocity and work cycle time. For applications that require operation outside of the recommended temperature range, contact Tolomatic.**

LARGE FRAME MOTORS AND SMALLER SIZE ACTUATORS: Cantilevered motors need to be supported, if subjected to continuous rapid reversing duty and/or under dynamic conditions.

SIDE LOADING CONSIDERATIONS: Rod screw actuators are designed to push guided and supported loads and are not meant for applications that require substantial side loading. Please contact Tolomatic for details regarding side loading capabilities.

Sold & Serviced By:



Toll Free Phone (877) SERV098
 Toll Free Fax (877) SERV099
 www.electromate.com
 sales@electromate.com

GSA/GSM Electric Rod-Style Actuator

SIZE: 12

PERFORMANCE

MAX. LOAD WEIGHT & GUIDE ROD DEFLECTION

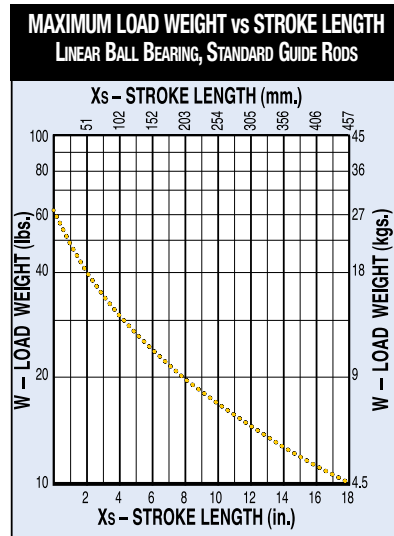

Linear ball bearings are not available with stainless steel guide rod option.

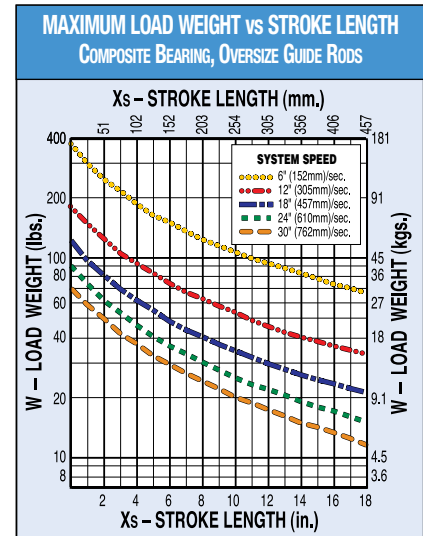
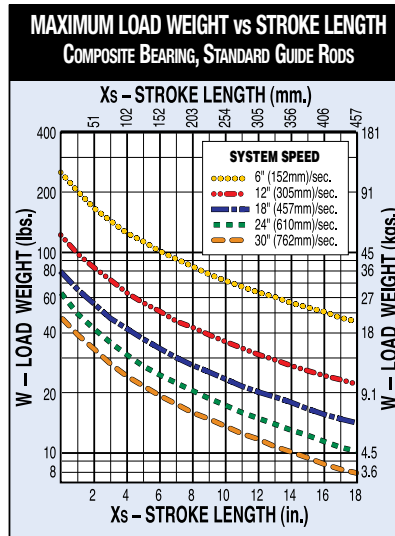

DO NOT EXCEED MAXIMUM LOAD CURVE

Maximum load values are based on 200 million linear inches of travel.

- To obtain most accurate results, stroke length should be adjusted by the distance between the center of mass of the load and tooling plate.

$$X_{adj} = X_s + X_{cm}$$

Then, use X_{adj} instead of X_s on the Maximum Load Weight vs. Stroke Length graph.

- For the off-center loads, calculate adjusted load weight using the following formula:

$$W_{adj} = W (1 + 0.67 Y_{cm})$$

where Y_{cm} is distance between center of mass of off-center load and center of tooling plate.

Then, use W_{adj} instead of W on Maximum Load Weight vs. Stroke Length graph.

- Using your stroke length and load weight, evaluate guide rod deflection. If the intersection point is above the highest curve (.064"), contact Tolomatic for assistance.

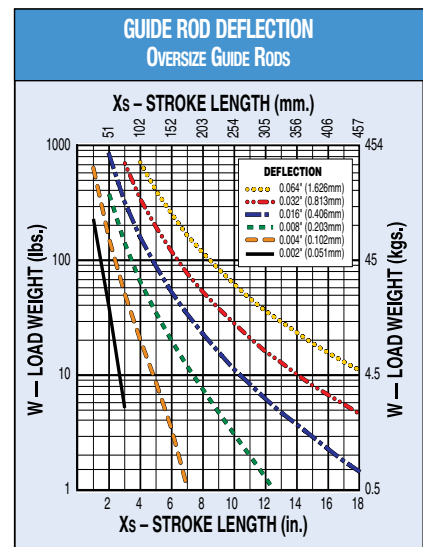
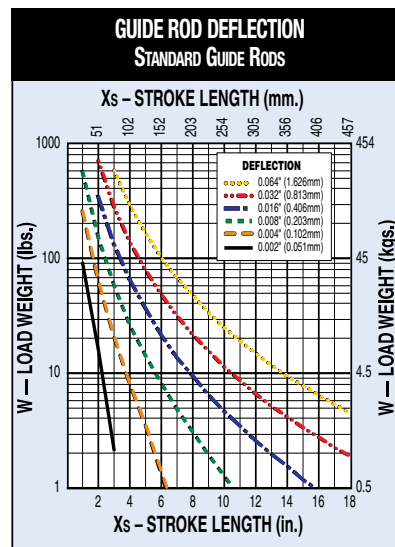

- Impact loading is not recommended for GSA/GSM actuators.
- Motor brakes may be required on vertically positioned actuators with plastic (solid) or ball nuts in applications with risk of load backdriving. (Actuators with bronze nuts will not backdrive for loads, thrusts within catalog specifications.)

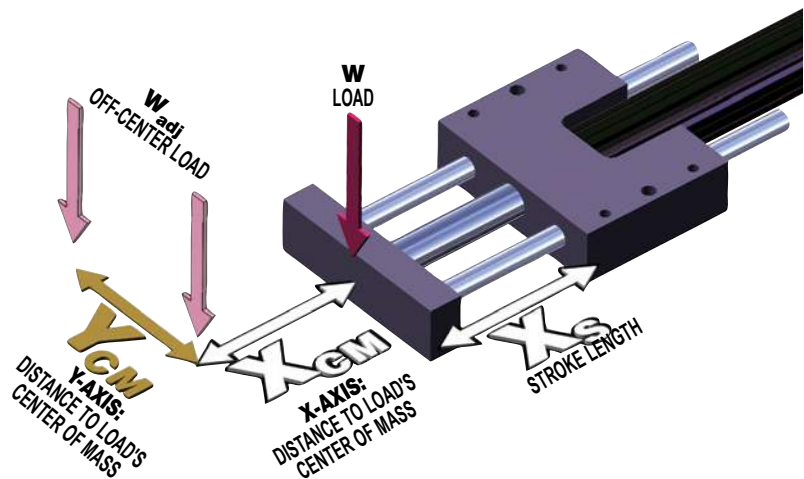

Sold & Serviced By:

ELECTROMATE

Toll Free Phone (877) 567-9398
Toll Free Fax (877) 567-9399

www.electromate.com
sales@electromate.com

Contact Tolomatic for assistance.

GSA/GSM Electric Rod-Style Actuator

SIZE: 16

PERFORMANCE

MAX. LOAD WEIGHT & GUIDE ROD DEFLECTION

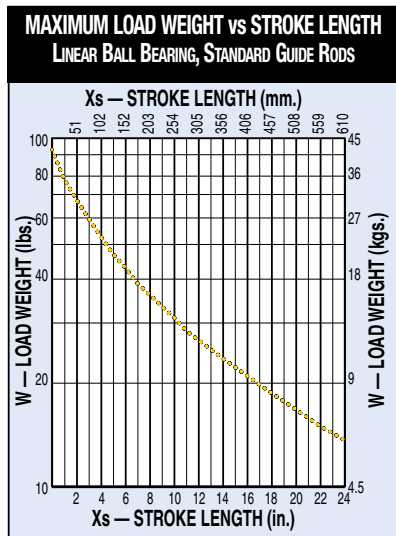

Linear ball bearings are not available with stainless steel guide rod option.

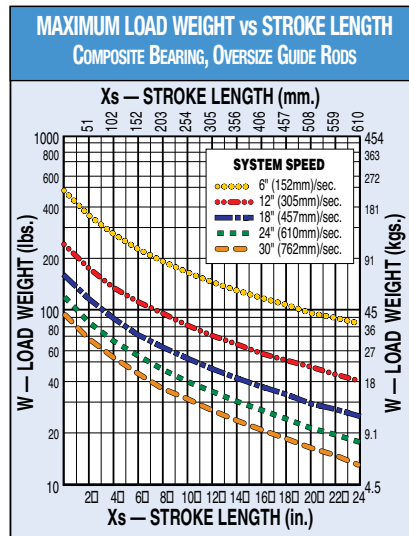
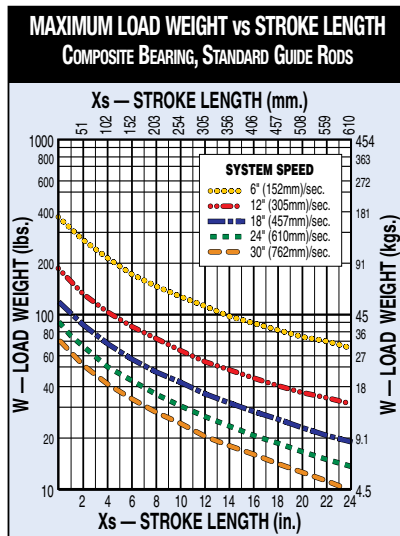

DO NOT EXCEED MAXIMUM LOAD CURVE

Maximum load values are based on 200 million linear inches of travel.

- To obtain most accurate results, stroke length should be adjusted by the distance between the center of mass of the load and tooling plate.

$$X_{adj} = X_s + X_{cm}$$

Then, use X_{adj} instead of X_s on the Maximum Load Weight vs. Stroke Length graph.

- For the off-center loads, calculate adjusted load weight using the following formula:

$$W_{adj} = W (1 + 0.53 Y_{cm})$$

where Y_{cm} is distance between center of mass of off-center load and center of tooling plate.

Then, use W_{adj} instead of W on Maximum Load Weight vs. Stroke Length graph.

- Using your stroke length and load weight, evaluate guide rod deflection. If the intersection point is above the highest curve (.064"), contact Tolomatic for assistance.

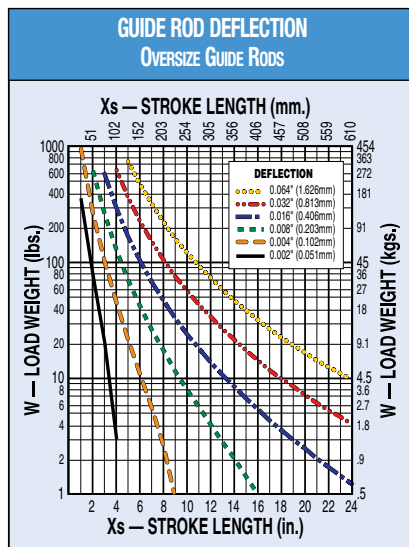
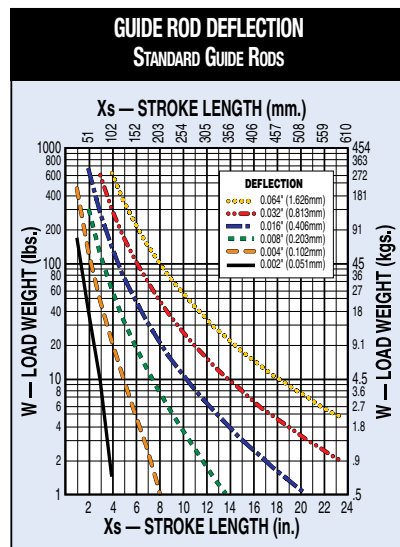

- Impact loading is not recommended for GSA/GSM actuators.
- Motor brakes may be required on vertically positioned actuators with plastic (solid) or ball nuts in applications with risk of load backdriving. (Actuators with bronze nuts will not backdrive for loads, thrusts within catalog specifications.)

Contact Tolomatic for assistance.

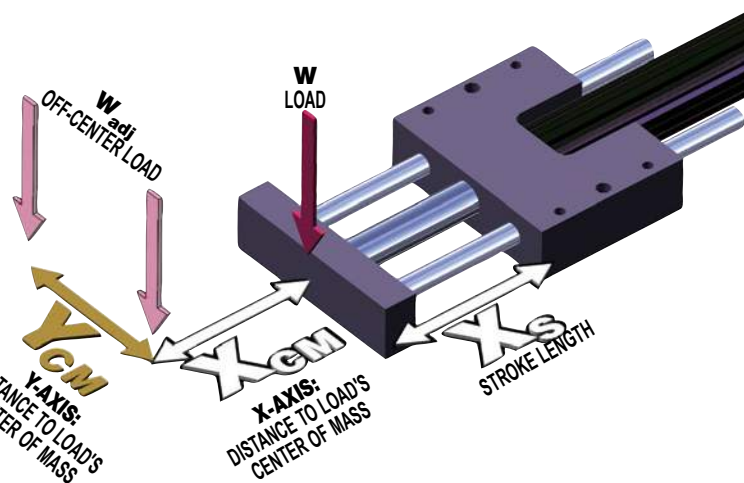

Sold & Serviced By:

ELECTROMATE

Toll Free Phone (877) 551-1198
Toll Free Fax (877) 551-1199

www.electromate.com
sales@electromate.com

GSA/GSM Electric Rod-Style Actuator

SIZE: 24

PERFORMANCE

MAX. LOAD WEIGHT & GUIDE ROD DEFLECTION

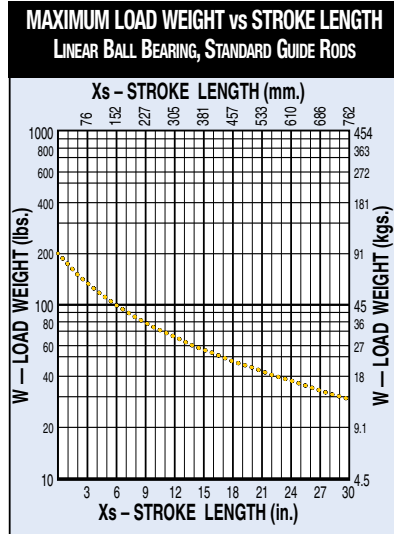

Linear ball bearings are not available with stainless steel guide rod option.

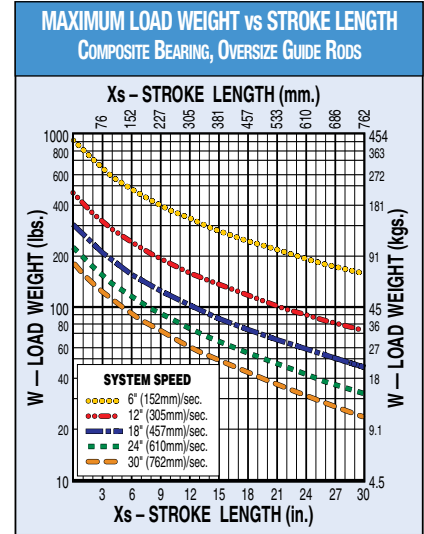
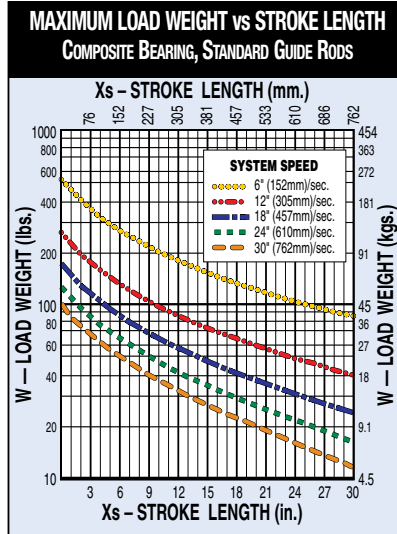

DO NOT EXCEED MAXIMUM LOAD CURVE

Maximum load values are based on 200 million linear inches of travel.

- To obtain most accurate results, stroke length should be adjusted by the distance between the center of mass of the load and tooling plate.

$$X_{adj} = X_s + X_{cm}$$

Then, use X_{adj} instead of X_s on the Maximum Load Weight vs. Stroke Length graph.

- For the off-center loads, calculate adjusted load weight using the following formula:

$$W_{adj} = W (1 + 0.40 Y_{cm})$$

where Y_{cm} is distance between center of mass of off-center load and center of tooling plate.

Then, use W_{adj} instead of W on Maximum Load Weight vs. Stroke Length graph.

- Using your stroke length and load weight, evaluate guide rod deflection. If the intersection point is above the highest curve (.064"), contact Tolomatic for assistance.

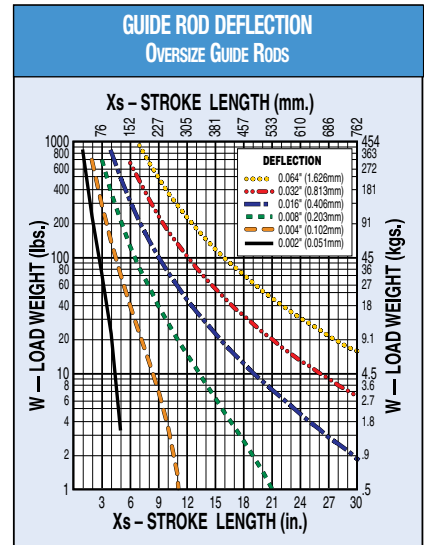
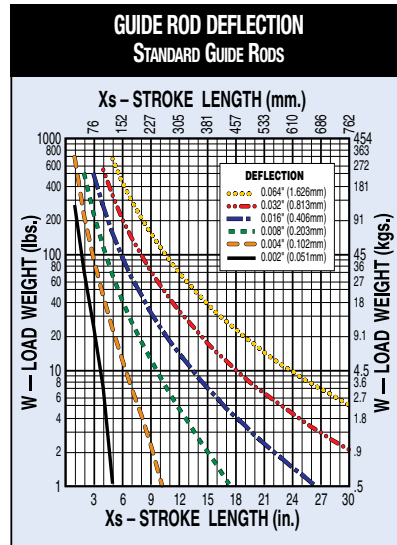

- Impact loading is not recommended for GSA/GSM actuators.
- Motor brakes may be required on vertically positioned actuators with plastic (solid) or ball nuts in applications with risk of load backdriving. (Actuators with bronze nuts will not backdrive for loads, thrusts within catalog specifications.)

Contact Tolomatic for assistance.

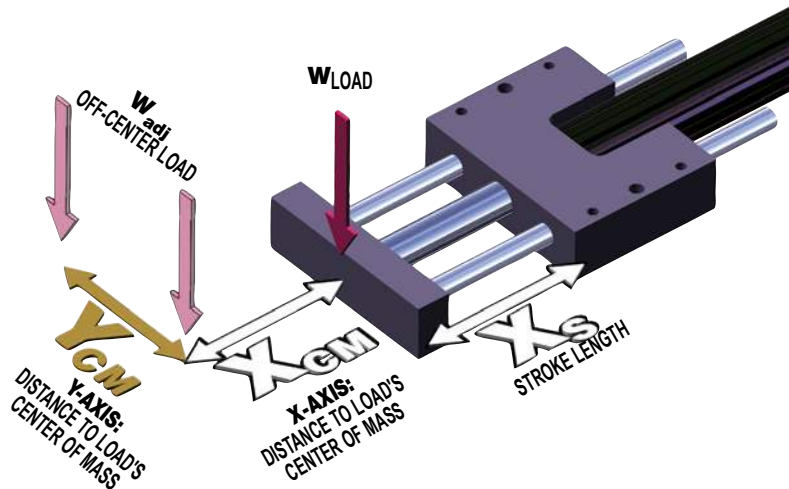

Sold & Serviced By:

ELECTROMATE

Toll Free Phone (877) SERVING

Toll Free Fax (877) SERVING

www.electromate.com

sales@electromate.com

GSA/GSM Electric Rod-Style Actuator

SIZE: 32

PERFORMANCE

MAX. LOAD WEIGHT & GUIDE ROD DEFLECTION

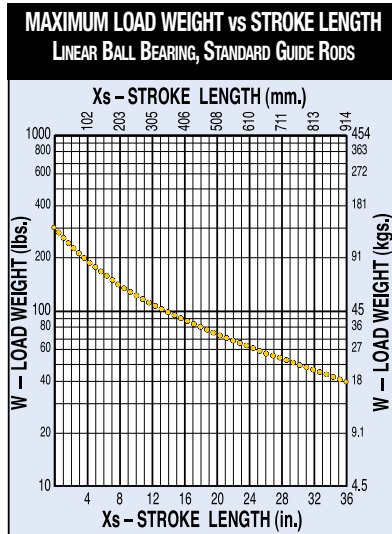

Linear ball bearings are not available with stainless steel guide rod option.

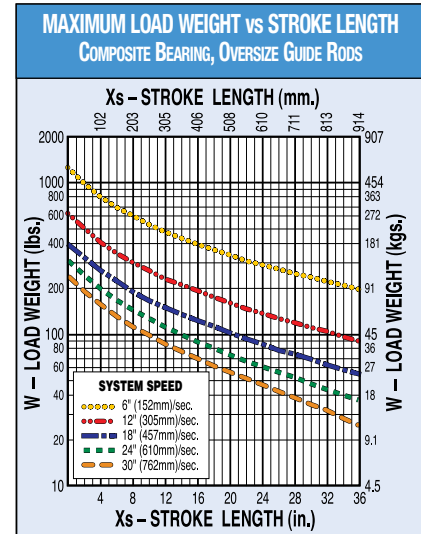
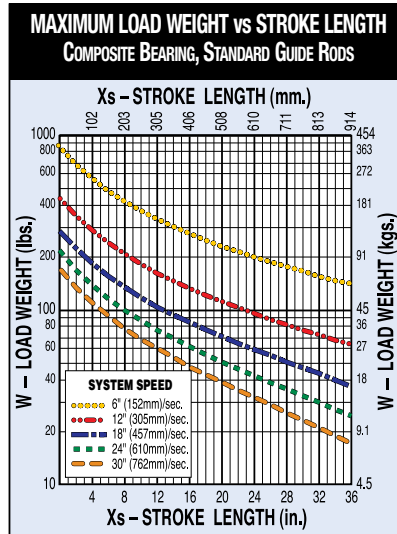

DO NOT EXCEED MAXIMUM LOAD

$$CURVE_{adj} = X_s + X_{cm} X_{adj}; X_s W_{adj} = W (1 + 0.30 Y_{cm}) Y_{cm} W_{adj} W$$

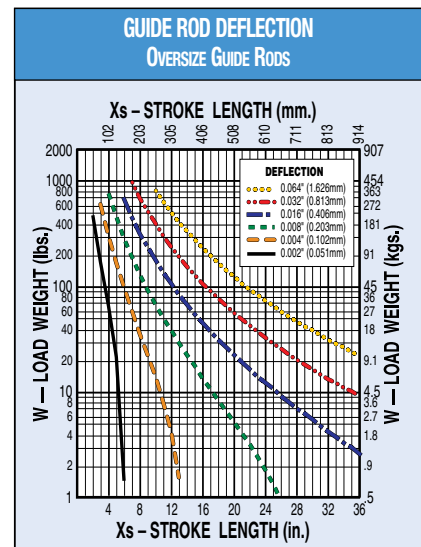
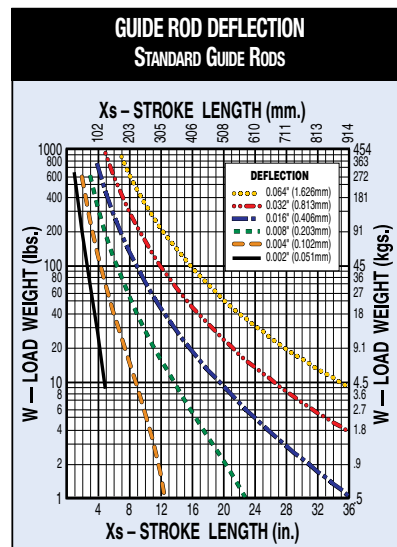

- Impact loading is not recommended for GSA/GSM actuators.
- Motor brakes may be required on vertically positioned actuators with plastic (solid) or ball nuts in applications with risk of load backdriving. (Actuators with bronze nuts will not backdrive for loads, thrusts within catalog specifications.)

Sold & Serviced By:

ELECTROMATE
Toll Free Phone (877) SERV098
Toll Free Fax (877) SERV099
www.electromate.com
sales@electromate.com

Contact Tolomatic for assistance.

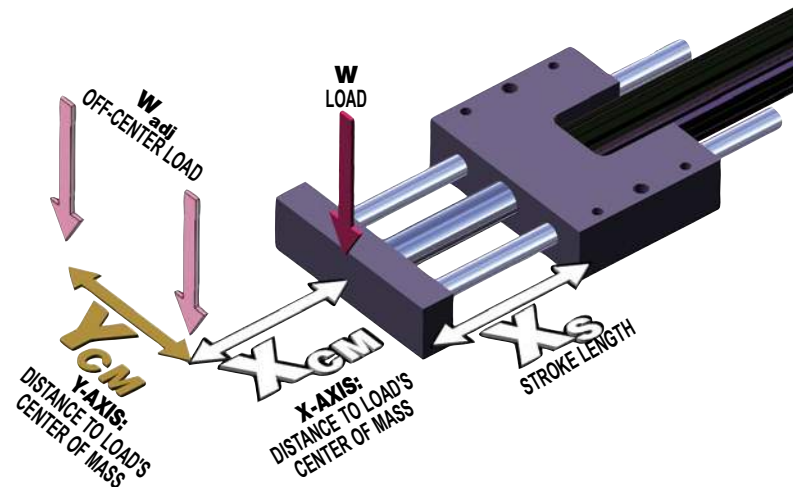

RSA Rod-Style Screw Driven Actuator

SIZE: ALL

ST ACTUATOR DIMENSIONS

3D CAD available at

Always use confi

to determine critical dimensions

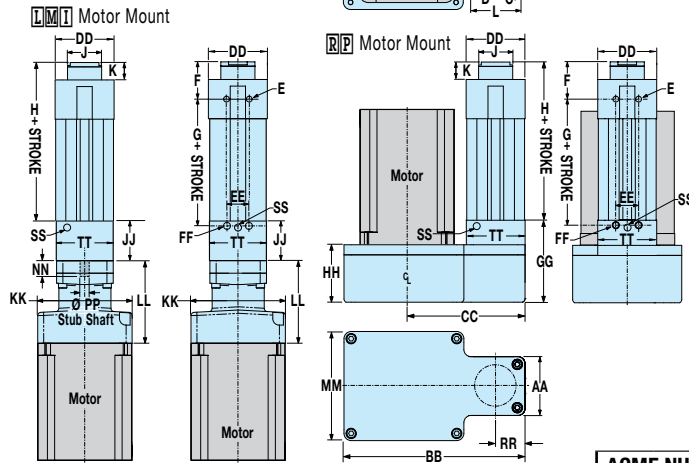

*NOTE: RSA64 HT (All Configurations) and RSA50 HT (Roller Nut Configuration ONLY) have 6 mounting holes, all other configurations have 4 mounting holes.



∞NOTE: YM code may change this dimension. Always use configured CAD model to determine critical dimensions

| | | | | | |
|-------------------------|--|---------|--------|------|------|
| *For BN08 & BNL08 only. | See table at right for BNML05 dimensions | Size 16 | BNML05 | | |
| | | | G | H | |
| | | | in | 2.51 | 3.37 |
| | | | mm | 63.8 | 85.6 |

| Size | | ACME NUT | | BALL NUT | | ROLLER NUT | | J Ø | K | RR | SS (2) | | | | | | |
|------|----|----------|-------|----------------------------|----------------------------|----------------------------|------|-------|-------|-------|--------|-------|-------|------|------|------|-------------|
| | | A | B | G | H | G | H | | | | | | | | | | |
| 12 | in | 0.906 | 0.391 | 5-40 \downarrow 0.50 | 1/4-28 \downarrow 0.75 | 8-32 \downarrow 0.25 | 0.81 | 2.17 | 2.76 | 2.17 | 2.76 | - | - | 0.56 | 0.31 | 0.56 | - |
| | mm | 23.01 | 9.93 | M3x0.5 \downarrow 12.7 | M6x1.0 \downarrow 19 | M4x0.7 \downarrow 6.3 | 20.7 | 55.1 | 70.1 | 55.1 | 70.1 | - | - | 14.2 | 7.8 | 14.3 | - |
| 16 | in | 0.500 | 1.063 | 8-32 \downarrow 0.50 | 5/16-24 \downarrow 0.75 | 8-32 \downarrow 0.25 | 1.06 | 2.13 | 2.99 | 2.13* | 2.99* | - | - | 0.69 | 0.43 | 0.69 | - |
| | mm | 12.70 | 27.00 | M4x0.7 \downarrow 12.7 | M8x1.25 \downarrow 19 | M4x0.7 \downarrow 6.3 | 26.9 | 54.2 | 75.9 | 54.2* | 75.9* | - | - | 17.5 | 10.9 | 17.5 | - |
| 24 | in | 0.875 | 1.603 | 10-24 \downarrow 0.79 | 7/16-20 \downarrow 1.00 | 1/4-20 \downarrow 0.33 | 1.11 | 2.90 | 3.84 | 3.36 | 4.30 | 4.54 | 5.21 | 1.18 | 0.43 | 1.96 | - |
| | mm | 22.23 | 40.72 | M5x0.8 \downarrow 20.0 | M10x1.25 \downarrow 25.0 | M6x1.0 \downarrow 8.6 | 28.2 | 73.7 | 97.5 | 85.4 | 109.2 | 115.2 | 132.3 | 30.0 | 10.9 | 49.8 | - |
| 32 | in | 1.181 | 1.969 | 1/4-20 \downarrow 0.70 | 7/16-20 \downarrow 1.13 | 5/16-18 \downarrow 0.47 | 1.43 | 3.87 | 5.05 | 5.05 | 6.23 | - | - | 1.25 | 0.50 | 1.29 | 1/16-27 NPT |
| | mm | 30.00 | 50.00 | M6x1.0 \downarrow 18.0 | M16x1.5 \downarrow 26.0 | M8x1.25 \downarrow 12.0 | 36.3 | 98.4 | 128.3 | 128.3 | 158.2 | - | - | 31.8 | 12.7 | 32.8 | 1/16-27 NPT |
| 50 | in | 1.969 | 3.000 | 5/16-18 \downarrow 1.00 | 3/4-16 \downarrow 1.50 | 3/8-16 \downarrow 0.75 | 1.95 | 4.78 | 6.44 | 5.78 | 7.44 | - | - | 1.75 | 0.70 | 1.86 | 1/8-27 NPT |
| | mm | 50.00 | 76.20 | M8x1.25 \downarrow 25.4 | M20x1.5 \downarrow 38.0 | M10x1.5 \downarrow 19.0 | 49.5 | 121.5 | 163.6 | 146.9 | 189.0 | - | - | 44.5 | 17.8 | 47.1 | 1/8-27 NPT |
| 64 | in | 1.969 | 3.500 | 7/16-14 \downarrow 1.50 | 3/4-16 \downarrow 1.50 | 7/16-14 \downarrow 0.88 | 2.37 | 6.94 | 8.90 | 8.94 | 10.90 | - | - | 2.25 | 0.68 | 2.29 | 1/8-27 NPT |
| | mm | 50.00 | 88.90 | M12x1.75 \downarrow 38.1 | M27x2.0 \downarrow 38.0 | M12x1.75 \downarrow 22.2 | 60.2 | 176.2 | 226.1 | 227.0 | 276.9 | - | - | 57.2 | 17.3 | 58.2 | 1/8-27 NPT |

| Size | Motor Frame | AA | BB | CC 1:1 | CC 2:1 | DD | EE | FF [2x] | ALL OTHER NUTS | | | | | ROLLER NUTS | | | | | MM∞ | NN | PP | |
|------|-------------|-------|-------|--------|--------|-------|-------|----------------------------|----------------------------|-------|------|-------|-------|-------------|-------|------|------|------|-------|-------|-------|-------|
| | | | | | | | | | GG | HH | JJ | KK∞ | LL∞ | GG | HH | JJ | KK∞ | LL∞ | | | | |
| 12 | 17 | in | 1.34 | 3.92 | 2.57 | NA | 1.13 | 0.500 | 8-32 \downarrow 0.25 | 1.66 | 1.66 | 0.72 | 1.66 | 1.85 | - | - | - | - | - | 2.26 | 0.61 | 0.188 |
| | | mm | 34.1 | 99.6 | 65.3 | NA | 28.6 | 12.70 | M4x0.7 \downarrow 6.3 | 42.1 | 42.1 | 18.3 | 42.0 | 47.0 | - | - | - | - | - | 57.3 | 15.5 | 4.78 |
| | 23 | in | 1.34 | 3.92 | 2.57 | NA | 1.13 | 0.500 | 8-32 \downarrow 0.25 | 1.66 | 1.66 | 0.72 | 2.00 | 2.49 | - | - | - | - | - | 2.26 | 0.61 | 0.188 |
| | | mm | 34.1 | 99.6 | 65.3 | NA | 28.6 | 12.70 | M4x0.7 \downarrow 6.3 | 42.1 | 42.1 | 18.3 | 50.8 | 63.2 | - | - | - | - | - | 57.3 | 15.5 | 4.78 |
| 16 | 23 | in | 1.34 | 4.04 | 2.64 | NA | 1.38 | 0.500 | 8-32 \downarrow 0.25 | 1.66 | 1.66 | 0.72 | 2.25 | 2.49 | - | - | - | - | - | 2.26 | 0.61 | 0.188 |
| | | mm | 34.1 | 102.7 | 67.0 | NA | 35.0 | 12.70 | M4x0.7 \downarrow 6.3 | 42.1 | 42.1 | 18.3 | 57.2 | 63.2 | - | - | - | - | - | 57.3 | 15.5 | 4.78 |
| 24 | 23 | in | 2.04 | 5.13 | 3.68 | 3.65 | 2.04 | 0.787 | 1/4-20 \downarrow 0.31 | 2.28 | 1.66 | 1.42 | 2.35 | 2.55 | 4.25 | 2.25 | 2.25 | 2.35 | 3.28 | 2.50 | 0.55 | 0.315 |
| | | mm | 51.8 | 130.2 | 93.4 | 92.6 | 51.8 | 19.98 | M6x1.0 \downarrow 8.6 | 57.9 | 42.2 | 36.0 | 59.7 | 64.8 | 107.8 | 57.2 | 57.2 | 59.7 | 83.3 | 63.5 | 14.0 | 8.00 |
| | 34 | in | 2.04 | 6.29 | 4.09 | 4.06 | 2.04 | 0.787 | 1/4-20 \downarrow 0.31 | 2.87 | 2.00 | 1.42 | 3.75 | 3.28 | 4.25 | 2.00 | 2.25 | 3.75 | 3.28 | 3.79 | 0.55 | 0.315 |
| | | mm | 51.8 | 159.8 | 103.9 | 103.2 | 51.8 | 19.98 | M6x1.0 \downarrow 8.6 | 72.8 | 50.7 | 36.0 | 95.3 | 83.3 | 107.8 | 50.7 | 57.2 | 95.3 | 83.3 | 96.3 | 14.0 | 8.00 |
| 32 | 23 | in | 2.58 | 5.89 | 4.18 | 4.20 | 2.58 | 0.950 | 5/16-18 \downarrow 0.50 | 3.19 | 2.00 | 1.79 | 3.00 | 2.63 | - | - | - | - | - | 2.58 | 0.69 | 0.394 |
| | | mm | 65.5 | 149.6 | 106.1 | 106.7 | 65.5 | 24.13 | M8x1.25 \downarrow 12.7 | 80.9 | 50.7 | 45.4 | 76.2 | 66.8 | - | - | - | - | - | 65.5 | 17.5 | 10.00 |
| | 34 | in | 2.58 | 7.52 | 5.03 | 5.00 | 2.58 | 0.950 | 5/16-18 \downarrow 0.50 | 3.19 | 2.00 | 1.79 | 3.75 | 2.38 | - | - | - | - | - | 4.25 | 0.69 | 0.394 |
| | | mm | 65.5 | 190.9 | 127.8 | 126.9 | 65.5 | 24.13 | M8x1.25 \downarrow 12.7 | 80.9 | 50.7 | 45.4 | 95.3 | 60.5 | - | - | - | - | - | 108.0 | 17.5 | 10.00 |
| 50 | 23 | in | 3.71 | 8.51 | 6.28 | 6.24 | 3.71 | 1.18 | 3/8-16 \downarrow 0.68 | 3.60 | 2.22 | 2.13 | 3.00 | 3.30 | - | - | - | - | - | 3.69 | 1.36 | 0.500 |
| | | mm | 94.2 | 216.2 | 159.6 | 158.5 | 94.1 | 30.0 | M10x1.5 \downarrow 17.5 | 91.3 | 56.3 | 54.0 | 76.2 | 83.8 | - | - | - | - | - | 93.7 | 34.5 | 12.70 |
| | 34 | in | 3.71 | 8.51 | 6.28 | 6.24 | 3.71 | 1.18 | 3/8-16 \downarrow 0.68 | 3.60 | 2.27 | 2.13 | 3.95 | 3.05 | - | - | - | - | - | 3.69 | 1.36 | 0.500 |
| | | mm | 94.2 | 216.2 | 159.6 | 158.5 | 94.1 | 30.0 | M10x1.5 \downarrow 17.5 | 91.3 | 57.5 | 54.0 | 100.2 | 63.5 | - | - | - | - | - | 93.7 | 34.5 | 12.70 |
| 64 | 34 | in | 3.71 | 9.50 | 6.78 | 6.73 | 3.71 | 1.18 | 3/8-16 \downarrow 0.68 | 3.60 | 2.52 | 2.13 | 5.00 | 4.48 | - | - | - | - | - | 5.58 | 1.36 | 0.500 |
| | | mm | 94.2 | 241.3 | 172.1 | 171.1 | 94.1 | 30.0 | M10x1.5 \downarrow 17.5 | 91.3 | 63.9 | 54.0 | 127.0 | 77.4 | - | - | - | - | - | 141.7 | 34.5 | 12.70 |
| | 56 | in | 4.73 | 8.84 | 6.72 | 6.82 | 4.58 | 1.97 | 7/16-14 \downarrow 0.88 | 4.73 | 2.75 | 3.48 | 3.75 | 3.05 | - | - | - | - | - | 4.48 | 1.36 | 0.750 |
| | | mm | 120.2 | 224.6 | 170.7 | 173.2 | 116.3 | 50.0 | M12x1.75 \downarrow 22.2 | 120.2 | 69.9 | 88.3 | 95.2 | 77.5 | - | - | - | - | - | 113.8 | 34.5 | 19.05 |
| 56 | in | 4.73 | 10.05 | 7.21 | 7.12 | 4.58 | 1.97 | 7/16-14 \downarrow 0.88 | 4.73 | 2.85 | 3.48 | 5.00 | 4.48 | - | - | - | - | - | 5.73 | 1.36 | 0.750 | |
| | mm | 120.2 | 255.3 | 183.1 | 180.8 | 116.3 | 50.0 | M12x1.75 \downarrow 22.2 | 120.2 | 72.4 | 88.3 | 127.0 | 113.8 | - | - | - | - | - | 145.5 | 34.5 | 19.05 | |

RSA Rod-Style Screw Driven Actuator

SIZE: 32,50,64

3D CAD available at
Always use confi
to determine critical dimensions



HT ACTUATOR DIMENSIONS

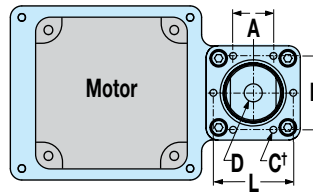

†NOTE: RSA64 HT (All Configurations) and RSA50 HT (Roller Nut Configuration ONLY) have 6 mounting holes, all other configurations have 4 mounting holes.

[LMI] Motor Mount

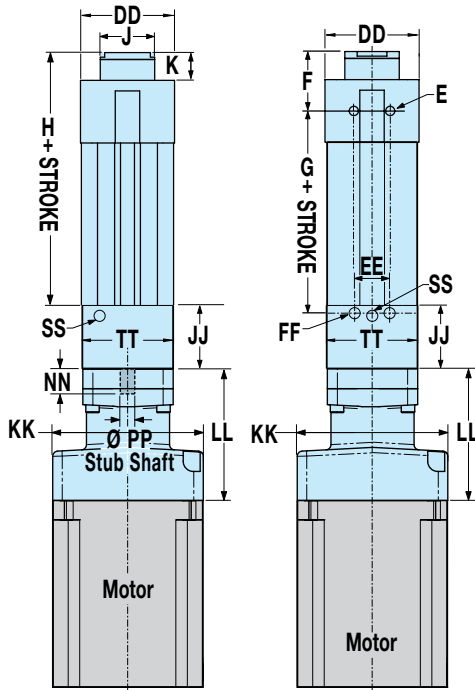

[RIP] Motor Mount

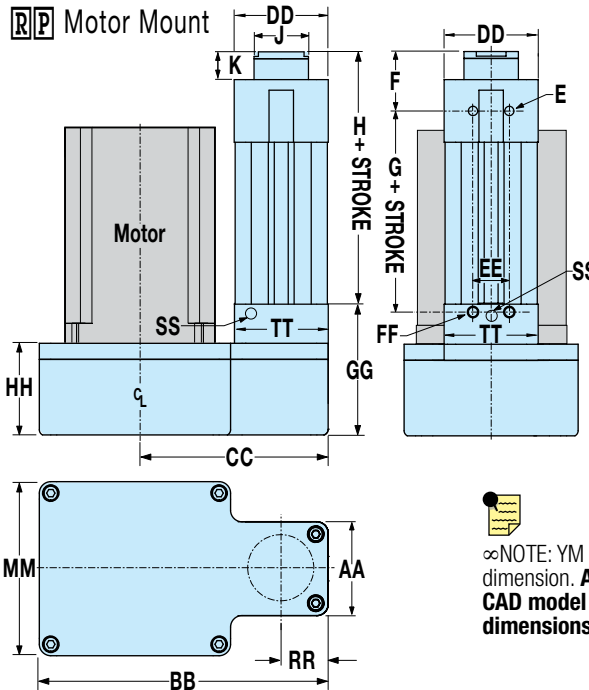

NOTE: See previous page for additional dimensions



∞NOTE: YM code may change this dimension. **Always use configured CAD model to determine critical dimensions**

| Size | | A | B | C† | D | E | F | J | K | EE | KK [Frame Size] ∞ | | | SS (2) |
|------|----|-------|-------|----------------|----------------|----------------|------|------|------|-------|-------------------|-------|-------|-------------|
| | | | | | | | | | | | 23 | 34 | 56 | |
| 32 | in | 1.181 | 1.969 | 1/4-20 ∓0.70 | 7/16-20 ∓1.13 | 1/4-20 ∓0.33 | 1.43 | 1.25 | 0.50 | 0.950 | 3.00 | 3.75 | NA | 1/16-27 NPT |
| | mm | 30.00 | 50.00 | M6x1.0 ∓18.0 | M16x1.5 ∓26.0 | M6x1.0 ∓8.6 | 36.3 | 31.8 | 12.7 | 24.13 | 76.2 | 95.3 | NA | 1/16-27 NPT |
| 50 | in | 1.969 | 3.000 | 5/16-18 ∓0.47 | 3/4-16 ∓1.50 | 5/16-18 ∓0.47 | 1.95 | 1.75 | 0.70 | 1.18 | 3.00 | 3.95 | 5.00 | 1/8-27 NPT |
| | mm | 50.00 | 76.20 | M8x1.25 ∓12.0 | M20x1.5 ∓38.0 | M8x1.25 ∓12.0 | 49.5 | 49.5 | 17.8 | 30.0 | 76.2 | 100.2 | 127.0 | 1/8-27 NPT |
| 64 | in | 1.969 | 3.500 | 1/2-13 ∓0.75 | 1-1/4-12 ∓2.50 | 7/16-14 ∓0.88 | 2.37 | 2.25 | 0.68 | 1.97 | NA | 3.75 | 5.00 | 1/8-27 NPT |
| | mm | 50.00 | 88.90 | M12x1.75 ∓18.0 | M27x2.0 ∓63.5 | M12x1.75 ∓22.2 | 60.2 | 57.2 | 17.3 | 50.0 | NA | 95.3 | 127.0 | 1/8-27 NPT |

| Size | BZ10 | | ROLLER NUTS | | | | | | | | | | | | | | | | | | | |
|------|------|-------|-------------|-------|-------|------|-------|--------|--------|-------|-------|-------|------|-----------------|-------|-------|-------|-------|------|-------|------|-------|
| | G | H | G | H | L | AA | BB | CC 1:1 | CC 2:1 | DD | GG | HH∞ | JJ | LL [Frame Size] | | | MM | NN | PP | RR | TT | |
| | | | | | | | | | | | | | | 23 | 34 | 56 | | | | | | |
| 32 | in | 3.87 | 5.05 | 5.92 | 5.74 | NA | 3.25 | 7.88 | 5.56 | 5.55 | 2.58 | 5.83 | 2.33 | 3.50 | 4.14 | 4.10 | NA | 4.38 | 1.69 | 0.625 | 1.63 | 3.25 |
| | mm | 98.4 | 128.3 | 150.4 | 145.7 | NA | 82.6 | 200.0 | 141.3 | 140.8 | 65.5 | 148.1 | 59.2 | 88.9 | 105.1 | 104.2 | NA | 111.1 | 43.0 | 15.9 | 41.3 | 82.6 |
| 50 | in | 4.78 | 6.44 | 7.21 | 8.41 | 3.00 | 5.88 | 11.00 | 7.85 | 7.92 | 3.71 | 6.80 | 3.00 | 3.80 | NA | 5.21 | 5.41 | 5.88 | 2.30 | 0.730 | 2.83 | 3.71 |
| | mm | 121.5 | 163.6 | 183.1 | 213.6 | 76.2 | 149.2 | 279.4 | 199.3 | 201.1 | 94.2 | 172.7 | 76.2 | 96.5 | NA | 132.4 | 137.4 | 149.2 | 58.4 | 18.54 | 71.8 | 94.2 |
| 64 | in | 7.80 | 9.29 | 7.80 | 9.29 | 3.50 | 6.88 | 12.10 | 8.81 | 8.75 | 4.58 | 7.75 | 3.50 | 4.50 | NA | 5.88 | 5.88 | 6.88 | 1.85 | 0.999 | 3.30 | 4.58 |
| | mm | 198 | 235.9 | 198.0 | 235.9 | 88.9 | 174.6 | 306.1 | 223.9 | 222.3 | 116.3 | 196.9 | 88.9 | 108.0 | NA | 149.3 | 149.3 | 174.6 | 47.1 | 25.37 | 83.8 | 116.3 |

| Size | BALL NUTS | | ALL OTHER NUTS | | | | | | | | | | | | | | | | | |
|------|-----------|-------|----------------|------|-------|--------|--------|-------|-------|-------|------|-----------------|-------|-------|-------|-------|------|-------|------|-------|
| | G | H | L | AA | BB | CC 1:1 | CC 2:1 | DD | GG | HH∞ | JJ | LL [Frame Size] | | | MM | NN | PP | RR | TT | |
| | | | | | | | | | | | | 23 | 34 | 56 | | | | | | |
| 32 | in | 5.05 | 6.23 | NA | 2.58 | 7.52 | 4.83 | 4.8 | 2.58 | 3.19 | 2.00 | 1.79 | 4.14 | 4.10 | NA | 4.25 | 1.75 | 0.531 | 1.29 | 2.58 |
| | mm | 128.3 | 158.2 | NA | 65.5 | 190.9 | 122.8 | 121.9 | 65.5 | 80.9 | 50.7 | 45.4 | 105.1 | 104.2 | NA | 108 | 44.5 | 13.49 | 32.8 | 65.5 |
| 50 | in | 6.78 | 7.87 | NA | 3.71 | 9.50 | 6.68 | 6.62 | 3.71 | 3.60 | 2.20 | 2.13 | NA | 5.36 | 5.41 | 5.58 | 2.30 | 0.730 | 1.85 | 3.71 |
| | mm | 172.1 | 200.0 | NA | 94.2 | 241.3 | 169.6 | 168.1 | 94.2 | 91.3 | 55.9 | 54.0 | NA | 136.2 | 137.4 | 141.7 | 58.4 | 18.54 | 47.1 | 94.2 |
| 64 | in | 9.29 | 11.7 | 3.50 | 6.88 | 12.1 | 8.81 | 8.75 | 4.58 | 7.75 | 3.50 | 4.50 | NA | 5.88 | 5.88 | 6.88 | 1.85 | 0.999 | 3.30 | 4.58 |
| | mm | 235.9 | 298.2 | 88.9 | 174.6 | 306.1 | 223.9 | 222.3 | 116.3 | 196.9 | 88.9 | 108.0 | NA | 149.3 | 149.3 | 174.6 | 47.1 | 25.37 | 83.8 | 116.3 |

GSA Electric Rod-Style Actuator

SIZE: ALL

3D CAD available at
Always use confi
to determine critical dimensions



| Size | | K | L | M Ø [2x] | N | P | R | S | T Ø [4x] | U | V | W | X Ø [4x] | Y |
|------|----|--------|-------|-------------------------|------|-------|------|-------|---------------------------|-------|-------|--------|-------------------------|-------|
| 12 | in | 4.500 | 2.000 | 0.375 \Downarrow 0.50 | 1.20 | 0.297 | 1.25 | 1.250 | 1/4-20 \Downarrow 0.50 | 0.750 | 1.500 | 3.406 | 0.250 \Downarrow 0.38 | 5.68 |
| | mm | 114.30 | 50.80 | 10.00 \Downarrow 12.7 | 30.5 | 7.54 | 31.8 | 31.75 | M6x1.0 \Downarrow 12.7 | 19.05 | 38.10 | 86.51 | 6.00 \Downarrow 9.5 | 144.1 |
| 16 | in | 5.438 | 2.500 | 0.375 \Downarrow 0.50 | 1.70 | 0.516 | 1.75 | 1.625 | 1/4-20 \Downarrow 0.50 | 1.000 | 1.750 | 3.969 | 0.250 \Downarrow 0.38 | 6.42 |
| | mm | 138.13 | 63.50 | 10.00 \Downarrow 12.7 | 43.2 | 13.11 | 44.5 | 41.28 | M6x1.0 \Downarrow 12.7 | 25.40 | 44.45 | 100.81 | 6.00 \Downarrow 9.5 | 163.1 |
| 24 | in | 7.000 | 3.000 | 0.500 \Downarrow 0.50 | 2.15 | 0.438 | 2.25 | 1.625 | 5/16-18 \Downarrow 0.63 | 1.250 | 2.750 | 5.125 | 0.313 \Downarrow 0.50 | 8.14 |
| | mm | 177.80 | 76.20 | 12.00 \Downarrow 12.7 | 54.6 | 11.13 | 57.2 | 41.28 | M8x1.25 \Downarrow 16.0 | 31.75 | 69.85 | 130.18 | 8.00 \Downarrow 9.5 | 206.6 |
| 32 | in | 9.000 | 3.500 | 0.500 \Downarrow 0.50 | 2.65 | 0.594 | 2.75 | 2.125 | 3/8-16 \Downarrow 0.75 | 1.750 | 2.750 | 5.812 | 0.375 \Downarrow 0.50 | 9.81 |
| | mm | 228.60 | 88.90 | 12.00 \Downarrow 12.7 | 67.3 | 15.09 | 69.9 | 53.98 | M10x1.5 \Downarrow 19.1 | 44.45 | 69.85 | 147.62 | 10.00 \Downarrow 12.7 | 249.0 |

| Size | Motor Frame | AA | BB | CC 1:1 | CC 2:1 | DD | EE | FF [2x] | GG | HH | JJ | KK ∞ | LL ∞ | MM ∞ | |
|------|-------------|----|------|--------|--------|-------|-------|-------------------------|---------------------------|------|------|-------------|-------------|-------------|-------|
| 12 | 17 | in | 1.34 | 3.92 | 2.63 | NA | 1.13 | 0.500 | 8-32 \Downarrow 0.25 | 1.66 | 0.72 | 1.66 | 1.85 | 2.26 | |
| | | mm | 34.1 | 99.5 | 66.9 | | 28.6 | 12.70 | M4x0.7 \Downarrow 6.3 | 42.1 | 18.3 | 42.0 | 47.0 | 57.3 | |
| | 23 | in | 1.34 | 3.92 | 2.63 | | 1.13 | 0.500 | 8-32 \Downarrow 0.25 | 1.66 | 0.72 | 2.00 | 2.49 | 2.26 | |
| | | mm | 34.1 | 99.5 | 66.9 | | 28.6 | 12.70 | M4x0.7 \Downarrow 6.3 | 42.1 | 18.3 | 50.8 | 63.2 | 57.3 | |
| 16 | 23 | in | 1.34 | 4.04 | 2.88 | 1.38 | 0.500 | 8-32 \Downarrow 0.25 | 1.66 | 0.72 | 2.25 | 2.49 | 2.26 | | |
| | | mm | 34.1 | 102.7 | 73.2 | 35.0 | 12.70 | M4x0.7 \Downarrow 6.3 | 42.1 | 18.3 | 57.2 | 63.2 | 57.3 | | |
| 24 | 23 | in | 2.04 | 5.13 | 3.78 | 3.75 | 2.04 | 0.787 | 1/4-20 \Downarrow 0.31 | 2.28 | 1.66 | 1.42 | 2.35 | 2.55 | 2.50 |
| | | mm | 51.8 | 130.2 | 96.1 | 95.3 | 51.8 | 20.00 | M6x1.0 \Downarrow 8.6 | 57.9 | 42.2 | 36.0 | 59.7 | 64.8 | 63.5 |
| | 34 | in | 2.04 | 6.29 | 4.20 | 4.17 | 2.04 | 0.787 | 1/4-20 \Downarrow 0.31 | 2.87 | 2.00 | 1.42 | 3.75 | 3.28 | 3.79 |
| | | mm | 51.8 | 159.8 | 106.6 | 105.9 | 51.8 | 20.00 | M6x1.0 \Downarrow 8.6 | 72.8 | 50.7 | 36.0 | 95.3 | 83.3 | 96.3 |
| 32 | 23 | in | 2.58 | 5.89 | 4.26 | 4.28 | 2.58 | 0.950 | 5/16-18 \Downarrow 0.50 | 3.19 | 2.00 | 1.79 | 3.00 | 2.63 | 2.58 |
| | | mm | 65.5 | 149.6 | 108.3 | 108.9 | 65.5 | 24.13 | M8x1.25 \Downarrow 12.7 | 80.9 | 50.7 | 45.4 | 76.2 | 66.8 | 65.5 |
| | 34 | in | 2.58 | 7.52 | 5.11 | 5.08 | 2.58 | 0.950 | 5/16-18 \Downarrow 0.50 | 3.19 | 2.00 | 1.79 | 3.75 | 2.38 | 4.25 |
| | | mm | 65.5 | 190.9 | 129.9 | 129.0 | 65.5 | 24.13 | M8x1.25 \Downarrow 12.7 | 80.9 | 50.7 | 45.4 | 95.3 | 60.5 | 108.0 |



∞ NOTE: YM code may change this dimension. Always use configured CAD to determine critical dimensions

Sold & Serviced By:



Toll Free Phone (877) SERV098
Toll Free Fax (877) SERV099
www.electromate.com
sales@electromate.com

RSA/RSM Rod End Options

SIZE: ALL

3D CAD available at
Always use confi
to determine critical dimensions



SRE SPHERICAL ROD END

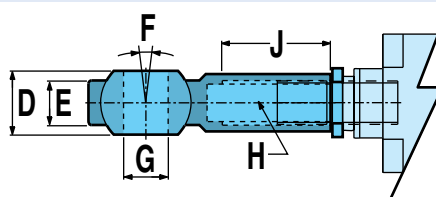
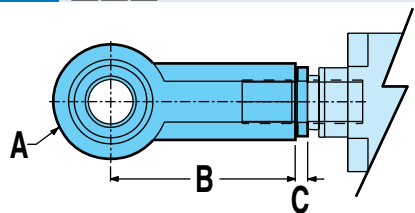

Allows for slight misalignment between the load and the actuator (radial and angular). Uses an industry-standard bearing.

| Size | | A Ø | B | C | D | E | F | G Ø | H | J |
|------|----|-------|--------|------|-------|-------|-------|----------|----------|------|
| 12 | in | 0.750 | 1.312 | 0.10 | 0.375 | 0.281 | 10° | 0.250 | 1/4-28 | 0.75 |
| | mm | 18.00 | 30.00 | 2.5 | 9.00 | 6.80 | | 6.00 | M6x1 | 12.0 |
| 16 | in | 0.875 | 1.375 | 0.10 | 0.437 | 0.344 | | 0.312 | 5/16-24 | 0.75 |
| | mm | 24.00 | 36.00 | 2.5 | 12.00 | 9.00 | | 8.00 | M8x1.25 | 16.0 |
| 24 | in | 1.125 | 1.812 | 0.15 | 0.560 | 0.437 | | 0.438 | 7/16-20 | 1.06 |
| | mm | 28.00 | 43.00 | 3.8 | 14.00 | 10.50 | | 10.00 | M10x1.25 | 20.0 |
| 32 | in | 1.125 | 1.812 | 0.15 | 0.560 | 0.437 | | 0.437 | 7/16-20 | 1.06 |
| | mm | 42.00 | 64.00 | 4.8 | 21.00 | 15.00 | | 16.00 | M16x1.5 | 28.0 |
| 50 | in | 1.750 | 2.875 | 0.19 | 0.875 | 0.687 | | 0.750 | 3/4-16 | 1.75 |
| | mm | 50.00 | 77.00 | 4.8 | 25.00 | 18.00 | | 20.00 | M20x1.5 | 33.0 |
| 64ST | in | 1.750 | 2.875 | 0.19 | 0.875 | 0.687 | | 0.750 | 3/4-16 | 1.75 |
| | mm | 70.00 | 110.00 | 6.4 | 37.00 | 25.00 | | 30.00 | M27x2.0 | 51.0 |
| 64HT | in | 2.750 | 4.125 | 0.19 | 1.375 | 1.000 | 1.00 | 1-1/4-12 | 2.13 | |
| | mm | 70.00 | 110.00 | 6.4 | 37.00 | 25.00 | 30.00 | M27x2.0 | 51.0 | |

CLV CLEVIS ROD END

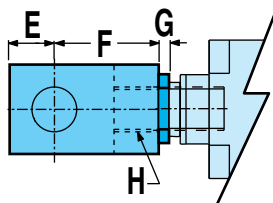
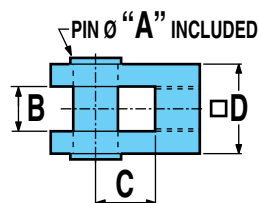

Used with the externally threaded rod end when the actuator has to compensate for misalignment or pivot about an axis.

| Size | | A Ø | B | C | D | E | F | G | H |
|------|----|-------------|-------------|------|------|------|--------|------|----------|
| 12 | in | 0.250 | 0.250 | 0.50 | 0.50 | 0.25 | 0.812 | 0.10 | 1/4-28 |
| | mm | 6.10 / 6.07 | 6.01 / 6.14 | 12.0 | 12.0 | 9.5 | 24.00 | 2.5 | M6x1.0 |
| 16 | in | 0.375 | 0.375 | 0.50 | 0.75 | 0.38 | 0.875 | 0.10 | 5/16-24 |
| | mm | 8.10 / 8.07 | 6.01 / 6.14 | 16.0 | 16.0 | 13.0 | 32.00 | 2.5 | M8x1.25 |
| 24 | in | 0.50 | 0.51 | 0.75 | 1.00 | 0.50 | 1.375 | 0.15 | 7/16-20 |
| | mm | 10.0 | 10.0 | 20.0 | 20.0 | 16.0 | 40.00 | 3.8 | M10x1.25 |
| 32 | in | 0.50 | 0.51 | 0.75 | 1.00 | 0.50 | 1.375 | 0.15 | 7/16-20 |
| | mm | 16.0 | 16.0 | 32.0 | 32.0 | 19.0 | 64.00 | 4.8 | M16x1.5 |
| 50 | in | 0.75 | 0.75 | 1.00 | 1.50 | 0.75 | 1.750 | 0.19 | 3/4-16 |
| | mm | 20.0 | 20.0 | 40.0 | 40.0 | 25.0 | 80.00 | 4.8 | M20x1.5 |
| 64ST | in | 0.75 | 0.75 | 1.00 | 1.50 | 0.75 | 1.750 | 0.19 | 3/4-16 |
| | mm | 30.0 | 30.0 | 54.0 | 55.0 | 45.0 | 110.00 | 6.4 | M27x2.0 |
| 64HT | in | 1.375 | 2.03 | 1.75 | 4.03 | 1.38 | 3.750 | 0.19 | 1-1/4-12 |
| | mm | 30.0 | 30.0 | 54.0 | 55.0 | 45.0 | 110.00 | 6.4 | M27x2.0 |

KEY TO SYMBOLS

▲ Indicates a note of high importance

⊗ Indicates incompatibility with option(s) or size(s)

📝 Make note of this item

RSA/RSM Rod End Options

SIZE: **ALL**

3D CAD available at
Always use confi
to determine critical dimensions



A I C ALIGNMENT COUPLER

INTERNALLY THREADED END

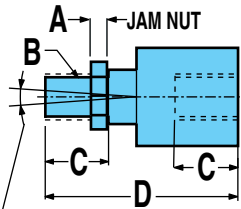

2 SPHERICAL MOTION,
0.0625 (1.6) RADIAL FLOAT

EXTERNALLY THREADED END

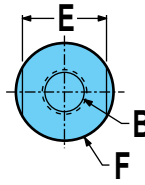
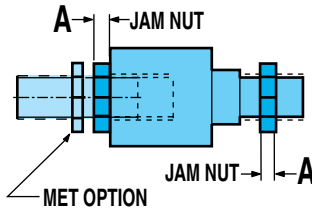

Used in combination with the externally threaded rod end to provide smooth motion and extends actuator life by preventing binding caused by angular or axial misalignment. Not available for use with clevis or trunnion mounts, as they must be rigidly mounted.

THE ALIGNMENT COUPLER COMES WITH AN INTERNAL THREAD. IF AN EXTERNAL THREAD IS PREFERRED, THE ADDITION OF THE "MET" OPTION IS REQUIRED.

If you need external thread, be sure to also order the **MET** external rod end

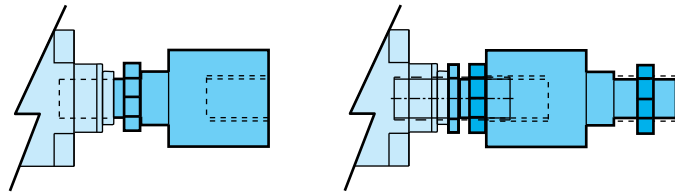

| Size | | A | B | C | D | E | F |
|------|----|------|----------|------|-------|------|------|
| 12 | in | 0.16 | 1/4-28 | 0.63 | 1.88 | 0.81 | 0.88 |
| | mm | — | — | — | — | — | — |
| 16 | in | 0.20 | 5/16-24 | 0.63 | 1.88 | 0.81 | 0.88 |
| | mm | — | — | — | — | — | — |
| 24 | in | 0.25 | 7/16-20 | 0.75 | 2.75 | 1.13 | 1.25 |
| | mm | 6.4 | M10x1.25 | 24.0 | 77.0 | 19.0 | 30.0 |
| 32 | in | 0.25 | 7/16-20 | 0.75 | 2.75 | 1.13 | 1.25 |
| | mm | 8.0 | M16x1.5 | 32.0 | 106.0 | 30.0 | 42.0 |
| 50 | in | 0.45 | 3/4-16 | 1.13 | 3.44 | 1.50 | 1.75 |
| | mm | 10.0 | M20x1.5 | 42.0 | 122.0 | 30.0 | 42.0 |
| 64ST | in | 0.45 | 3/4-16 | 1.13 | 3.44 | 1.50 | 1.75 |
| | mm | 13.5 | M27x2.0 | 54.0 | 147.0 | 32.0 | 55.0 |
| 64HT | in | 0.50 | 1-1/4-12 | 1.63 | 4.56 | 2.25 | 2.50 |
| | mm | 13.5 | M27x2.0 | 54.0 | 147.0 | 32.0 | 55.0 |

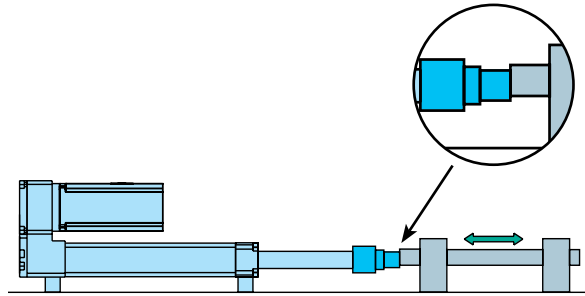

M E T EXTERNALLY THREADED ROD END



An alternative to the standard internally threaded end.

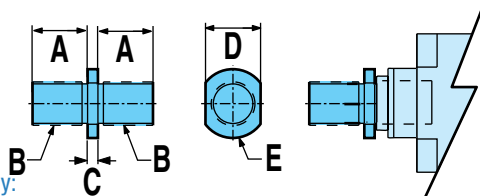

| Size | | A | B | C | D | E Ø |
|------|----|------|----------|------|-------|------|
| 12 | in | 0.50 | 1/4-28 | 0.10 | 0.315 | 0.42 |
| | mm | 12.7 | M6x1.0 | 2.5 | 8.00 | 10.7 |
| 16 | in | 0.50 | 5/16-24 | 0.10 | 0.375 | 0.48 |
| | mm | 12.7 | M8x1.25 | 2.5 | 10.00 | 12.2 |
| 24 | in | 0.87 | 7/16-20 | 0.15 | 0.750 | 0.97 |
| | mm | 22.1 | M10x1.25 | 3.8 | 19.00 | 24.6 |
| 32 | in | 0.87 | 7/16-20 | 0.15 | 0.750 | 0.97 |
| | mm | 28.0 | M16x1.5 | 4.8 | 19.00 | 24.6 |
| 50 | in | 1.50 | 3/4-16 | 0.19 | 1.250 | 1.48 |
| | mm | 38.1 | M-20x1.5 | 4.8 | 32.00 | 37.6 |
| 64ST | in | 1.50 | 3/4-16 | 0.19 | 1.250 | 1.48 |
| | mm | 38.1 | M27x2 | 6.4 | 32.00 | 38.1 |
| 64HT | in | 2.13 | 1-1/4-12 | 0.19 | 1.313 | 1.60 |
| | mm | 50.8 | M27x2 | 6.4 | 32.00 | 38.1 |

Sold & Serviced By:
ELECTROMATE

Toll Free Phone (877) SERV098
Toll Free Fax (877) SERV099
www.electromate.com
sales@electromate.com

RSA/RSM Mounting Options

SIZE: ALL

3D CAD available at
Always use confi
to determine critical dimensions



FFG FRONT FLANGE MOUNT



Used when a bottom-tapped mount is not an option or where bottom support mechanisms are

not feasible. Flange can be mounted directly to framework or a bulkhead

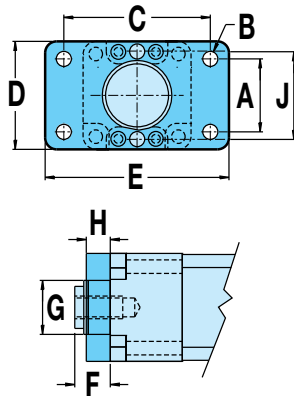

| Size | | A | B Ø | C | D | E | F | G Ø | H | J |
|---------|----|-------|-------|--------|-------|-------|------|------|------|------|
| 12 | in | 0.500 | 0.157 | 1.500 | 1.12 | 2.00 | 0.31 | 0.56 | 0.25 | – |
| | mm | 12.70 | 4.00 | 38.10 | 28.5 | 50.8 | 7.8 | 14.0 | 6.3 | – |
| 16 | in | 0.945 | 0.18 | 1.896 | 1.38 | 2.39 | 0.43 | 0.68 | 0.37 | – |
| | mm | 24.00 | 4.5 | 48.16 | 35.1 | 60.7 | 11.0 | 17.0 | 9.3 | – |
| 24 | in | 1.430 | 0.31 | 2.750 | 2.00 | 3.37 | 0.43 | 1.18 | 0.37 | – |
| | mm | 32.00 | 7.2 | 64.00 | 47.0 | 80.0 | 11.0 | 30.0 | 10.0 | – |
| 32 | in | 1.840 | 0.37 | 3.375 | 2.50 | 4.12 | 0.50 | 1.25 | 0.37 | – |
| | mm | 45.00 | 92.0 | 90.00 | 65.0 | 113.0 | 12.7 | 40.0 | 12.0 | – |
| 50ST | in | 2.760 | 0.43 | 4.687 | 3.75 | 5.50 | 0.70 | 1.75 | 0.62 | – |
| | mm | 63.00 | 12.2 | 126.00 | 97.0 | 153.0 | 17.7 | 50.0 | 16.0 | – |
| 50HT | in | 2.760 | 0.43 | 4.687 | 3.75 | 5.50 | 1.32 | 1.75 | 0.62 | – |
| | mm | 63.00 | 12.2 | 126.00 | 97.0 | 153.0 | 33.5 | 50.0 | 16.0 | – |
| 50HT RN | in | 2.760 | 0.43 | 7.000 | 3.75 | 8.00 | 1.32 | 1.75 | 0.62 | 3.00 |
| | mm | 63.00 | 12.2 | 177.80 | 97.0 | 203.2 | 33.5 | 50.0 | 16.0 | 76.2 |
| 64ST | in | 3.320 | 0.43 | 5.437 | 4.50 | 6.25 | 0.68 | 2.25 | 0.62 | – |
| | mm | 75.00 | 14.2 | 150.00 | 111.0 | 186.0 | 17.3 | 65.0 | 16.0 | – |
| 64HT | in | 3.320 | 0.58 | 8.000 | 4.50 | 9.00 | 0.86 | 2.25 | 0.80 | 3.50 |
| | mm | 75.00 | 14.7 | 203.2 | 114.3 | 228.6 | 21.8 | 65.0 | 20.3 | 88.9 |

M P 2 MOUNTING PLATE

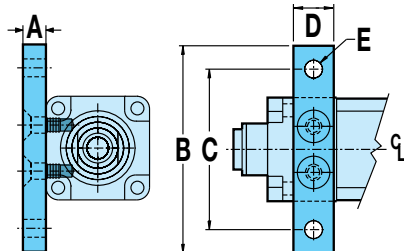

Used for mountings other than flush.

| Size | | A | B | C | D | E Ø |
|---------------------------------|----|------|-------|-------|-------|------|
| 12 | in | 0.50 | 2.25 | 1.75 | 0.40 | 0.19 |
| 17 FRAME | mm | 12.7 | 57.2 | 44.4 | 10.2 | 4.8 |
| 12 23 FRAME or YMH option | in | 0.63 | 2.50 | 2.00 | 0.40 | 0.19 |
| | mm | 16.0 | 63.5 | 50.8 | 10.2 | 4.8 |
| 16 | in | 0.63 | 2.50 | 2.00 | 0.40 | 0.19 |
| | mm | 16.0 | 63.5 | 50.8 | 10.2 | 4.8 |
| 24 | in | 0.50 | 3.50 | 2.75 | 1.50 | 0.44 |
| | mm | 12.0 | 78.0 | 62.0 | 25.4 | 6.7 |
| 32 | in | 0.50 | 4.00 | 3.25 | 1.50 | 0.44 |
| | mm | 12.0 | 104.0 | 84.0 | 31.80 | 8.70 |
| 50 | in | 0.75 | 5.75 | 4.75 | 1.75 | 0.56 |
| | mm | 20.0 | 146.1 | 120.7 | 44.5 | 14.2 |
| 50 RN | in | 1.25 | 5.75 | 4.75 | 1.75 | 0.56 |
| | mm | 31.8 | 146.1 | 120.7 | 44.5 | 14.2 |
| 64ST | in | 0.75 | 6.50 | 5.50 | 1.75 | 0.56 |
| | mm | 20.0 | 180.0 | 150.0 | 57.2 | 12.8 |
| 64HT | in | 1.25 | 6.50 | 5.50 | 1.75 | 0.56 |
| | mm | 31.8 | 180.0 | 150.0 | 44.5 | 12.8 |

KEY TO SYMBOLS

- ▲ Indicates a note of high importance
- ⊗ Indicates incompatibility with option(s) or size(s)
- 📄 Make note of this item

RSA/RSM Mounting Options

SIZE: **ALL**

3D CAD available at
Always use confi
to determine critical dimensions



T R R TRUNNION MOUNT



Used where space is limited in the rear of the actuator and when pivoting about an axis is required.

⊗ Not available with 12 or 16 size LMI (inline) motor mounting

RSA US standard
(Sizes: 24, 32, 50, 64)

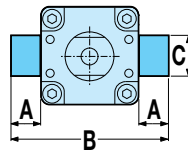

RSM Metric
(+RSA12, RSA16)

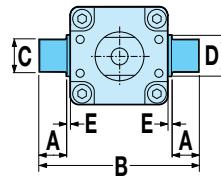

Both RSA US standard
RSM Metric

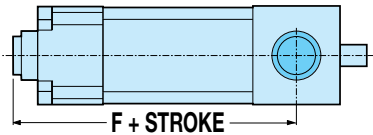

| RSA: US standard | Size | | A | B | C Ø | D Ø | E | F (LMI) | | | F (RP) | | |
|------------------|------|----|------|------|---------------|-------|-------|----------|----------|------------|----------|----------|------------|
| | | | | | | | | ACME NUT | BALL NUT | ROLLER NUT | ACME NUT | BALL NUT | ROLLER NUT |
| | | | | | | | | | | | | | |
| | 12 | in | 0.38 | 2.25 | 0.4374/0.4368 | 0.562 | 0.078 | NA | NA | NA | 3.09 | 3.09 | NA |
| | 16 | in | 0.38 | 2.25 | 0.4374/0.4368 | 0.562 | 0.078 | NA | NA | NA | 3.30 | 3.30 | NA |
| | 24 | in | 1.04 | 4.12 | 0.9999/0.9993 | NA | NA | 4.46 | 4.94 | 6.33 | 4.30 | 4.73 | 6.33 |
| | 32 | in | 1.00 | 4.58 | 0.9999/0.9993 | NA | NA | 6.06 | 7.24 | 7.42 | 5.65 | 6.83 | 7.42 |
| | 50ST | in | 1.06 | 5.83 | 0.9999/0.9993 | NA | NA | 7.44 | 8.44 | NA | 7.14 | 8.14 | NA |
| | 50HT | in | 1.06 | 5.83 | 0.9999/0.9993 | NA | NA | 7.44 | 8.44 | 9.07 | 7.14 | 8.14 | 9.07 |
| | 64ST | in | 1.06 | 6.70 | 0.9999/0.9993 | NA | NA | 9.90 | 11.90 | NA | 9.80 | 11.80 | NA |
| | 64HT | in | 1.25 | 7.92 | 0.9999/0.9993 | 1.50 | 0.42 | 10.29 | 12.74 | 10.29 | 10.29 | 12.74 | 10.29 |

| RSM: Metric | Size | | A | B | C Ø | D Ø | E | F (LMI) | | | F (RP) | | |
|-------------|------|----|------|-------|---------------|------|------|----------|----------|------------|----------|----------|------------|
| | | | | | | | | ACME NUT | BALL NUT | ROLLER NUT | ACME NUT | BALL NUT | ROLLER NUT |
| | | | | | | | | | | | | | |
| | 12 | mm | 9.5 | 57.2 | 12.000/11.981 | 14.2 | 2.0 | NA | NA | NA | 78.5 | 78.5 | NA |
| | 16 | mm | 9.5 | 57.2 | 12.000/11.980 | 14.2 | 2.0 | NA | NA | NA | 83.8 | 83.8 | NA |
| | 24 | mm | 8.6 | 75.7 | 11.999/11.981 | 18.0 | 3.3 | 113.4 | 125.5 | 160.8 | 109.1 | 120.2 | 160.8 |
| | 32 | mm | 16.0 | 107.0 | 15.999/15.981 | 25.0 | 4.74 | 153.8 | 183.8 | 188.5 | 143.5 | 173.5 | 188.5 |
| | 50ST | mm | 20.1 | 150.1 | 19.99/19.96 | 30.0 | 7.9 | 191.0 | 214.4 | NA | 181.3 | 206.7 | NA |
| | 50HT | mm | 20.1 | 150.1 | 19.99/19.96 | 30.0 | 7.9 | 191.0 | 214.4 | 230.3 | 181.3 | 206.7 | 230.3 |
| | 64ST | mm | 24.9 | 181.9 | 24.999/24.981 | 40.0 | 7.9 | 251.6 | 302.4 | NA | 248.9 | 299.7 | NA |
| | 64HT | mm | 24.9 | 181.9 | 24.999/24.981 | 40.0 | 7.9 | 261.3 | 323.6 | 261.3 | 261.3 | 323.6 | 261.3 |

B F G BACK FLANGE MOUNT

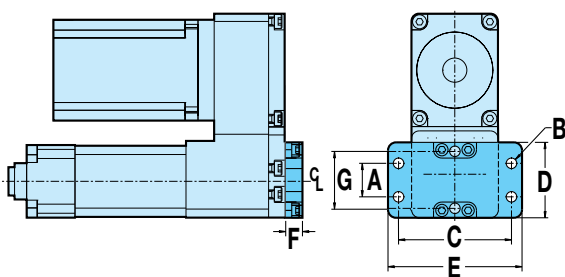

Used when a bottom-tapped mount is not an option or where bottom support mechanisms are not feasible. Flange can be mounted directly to framework or a bulkhead

⊗ Not available with LMI (inline) motor mounting

| Size | | A | B Ø | C | D | E | F | G |
|---------|----|-------|-------|--------|-------|-------|------|------|
| | | | | | | | | |
| 12 | in | 0.500 | 0.157 | 1.500 | 1.12 | 2.00 | 0.31 | – |
| | mm | 12.70 | 4.00 | 38.10 | 28.5 | 50.8 | 7.8 | – |
| 16 | in | 0.945 | 0.18 | 1.896 | 1.38 | 2.39 | 0.43 | – |
| | mm | 24.00 | 4.5 | 48.16 | 35.1 | 60.7 | 11.0 | – |
| 24 | in | 1.430 | 0.31 | 2.750 | 2.00 | 3.37 | 0.43 | – |
| | mm | 32.00 | 7.2 | 64.00 | 47.0 | 80.0 | 11.0 | – |
| 32 | in | 1.840 | 0.37 | 3.375 | 2.50 | 4.12 | 0.50 | – |
| | mm | 45.00 | 92.0 | 90.00 | 65.0 | 113.0 | 12.7 | – |
| 50ST | in | 2.760 | 0.43 | 4.687 | 3.75 | 5.50 | 0.70 | – |
| | mm | 63.00 | 12.2 | 126.00 | 97.0 | 153.0 | 17.7 | – |
| 50HT | in | 2.760 | 0.43 | 4.687 | 3.75 | 5.50 | 1.32 | – |
| | mm | 63.00 | 12.2 | 126.00 | 97.0 | 153.0 | 33.5 | – |
| 50HT RN | in | 2.760 | 0.43 | 7.000 | 3.75 | 8.00 | 1.32 | 3.00 |
| | mm | 63.00 | 12.2 | 177.80 | 97.0 | 203.2 | 33.5 | 76.2 |
| 64ST | in | 3.320 | 0.43 | 5.437 | 4.50 | 6.25 | 0.68 | – |
| | mm | 75.00 | 14.2 | 150.00 | 111.0 | 186.0 | 17.3 | – |
| 64HT | in | 3.320 | 0.58 | 8.000 | 4.50 | 9.00 | 0.86 | 3.50 |
| | mm | 75.00 | 14.7 | 203.2 | 114.3 | 228.6 | 21.8 | 88.9 |

Sold & Served By



Toll Free Phone (800) SERV098

Toll Free Fax (877) SERV099

www.electromate.com

sales@electromate.com

RSA Electric Rod-Style Actuator

SIZE: ALL

3D CAD available at
Always use confi
to determine critical dimensions



P C S EYE MOUNT & P C D CLEVIS MOUNT



Used when the actuator has to compensate for misalignment or pivot about an axis when free movement is available in the back of the actuator.

✗ Not available with LMI (inline) motor mounting



Used when the actuator has to compensate for misalignment or pivot about an axis when free movement is available in the back of the actuator.

✗ Not available with LMI (inline) motor mounting.

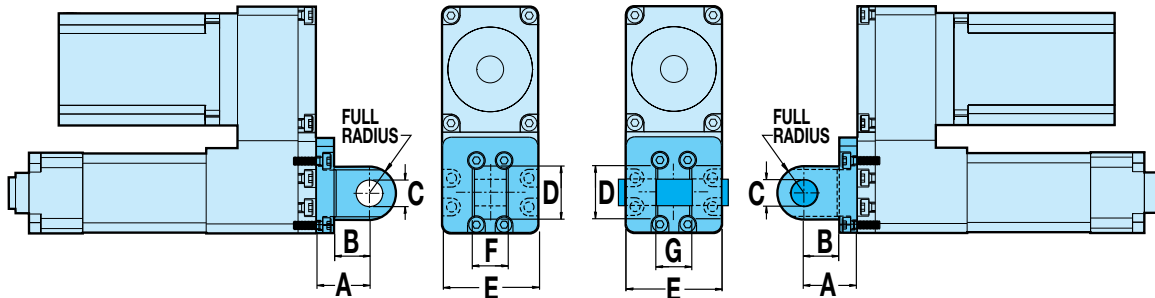

| Size | | A | B | C Ø | D | E | F | G |
|------|----|-------|-------|-----------------|------|-------|---------------|---------------|
| 12 | in | 0.750 | 0.500 | 0.3761 / 0.3751 | 0.75 | 1.34 | 0.447 / 0.442 | 0.453 / 0.448 |
| | mm | 19.05 | 12.70 | 10.018 / 10.000 | 19.0 | 34.0 | 11.35 / 11.22 | 11.51 / 11.38 |
| 16 | in | 0.750 | 0.500 | 0.3761 / 0.3751 | 0.75 | 1.34 | 0.447 / 0.442 | 0.453 / 0.448 |
| | mm | 19.05 | 12.70 | 10.018 / 10.000 | 19.0 | 34.0 | 11.35 / 11.22 | 11.51 / 11.38 |
| 24 | in | 1.062 | 0.687 | 0.501 / 0.500 | 1.00 | 1.98 | 0.750 / 0.745 | 0.755 / 0.751 |
| | mm | 22.00 | 12.00 | 10.03 / 10.00 | 20.0 | 50.2 | 25.80 / 25.60 | 26.12 / 26.01 |
| 32 | in | 1.062 | 0.687 | 0.501 / 0.500 | 1.00 | 2.58 | 0.750 / 0.745 | 0.755 / 0.751 |
| | mm | 27.00 | 15.00 | 12.03 / 12.00 | 26.0 | 65.5 | 31.80 / 31.60 | 32.12 / 32.01 |
| 50 | in | 1.875 | 1.375 | 0.751 / 0.750 | 1.50 | 3.60 | 1.250 / 1.245 | 1.255 / 1.251 |
| | mm | 36.00 | 20.00 | 16.03 / 16.00 | 40.0 | 91.5 | 49.80 / 49.60 | 50.12 / 50.01 |
| 64ST | in | 1.875 | 1.375 | 0.751 / 0.750 | 1.50 | 4.48 | 1.250 / 1.245 | 1.255 / 1.251 |
| | mm | 44.00 | 26.00 | 20.03 / 20.00 | 40.0 | 113.7 | 59.80 / 59.60 | 60.12 / 60.01 |
| 64HT | in | 2.335 | 1.535 | 1.003 / 1.002 | 2.00 | 4.48 | 1.500 / 1.495 | 1.505 / 1.501 |
| | mm | 59.31 | 38.99 | 28.03 / 28.00 | 50.8 | 113.7 | 39.90 / 39.80 | 40.10 / 40.00 |

X R OPTIONAL ROD EXTENSION

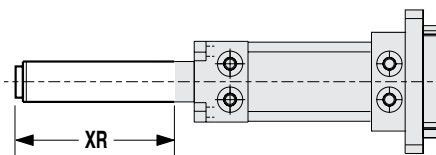

In **vertical applications only**, the thrust rod length can be extended by specifying the rod extension option. This does not increase the working stroke, only the length of the thrust rod.

NOTE: the XR dimension in the configurator string (extension + stroke) should not exceed the maximum stroke of the specific actuator. Consult Tolomatic for extensions greater than the maximum stroke length.

Maximum Stroke Length

| Size | | All Others | Roller Screws |
|------|----|------------|---------------|
| 12 | in | 18 | — |
| | mm | 457 | |
| 16 | in | 18 | — |
| | mm | 457 | |
| 24 | in | 24 | 18 |
| | mm | 610 | 457 |
| 32 | in | 36 | 18 |
| | mm | 914 | 457 |
| 50 | in | 48 | 18 |
| | mm | 1219 | 457 |
| 64 | in | 60 | 18 |
| | mm | 1524 | 457 |

Sold & Serviced By



Toll Free Phone (877) 957-9898
Toll Free Fax (877) 957-9898
www.electromate.com
sales@electromate.com

RSA Electric Rod-Style Actuator

SIZE: ALL

3D CAD available at
Always use confi
to determine critical dimensions



F M 2 FOOT MOUNTS



Used when mounting holes on bottom of actuator are not accessible.

⊗ Not available with LMI (inline) motor mounting

⊗ Not available with HT option

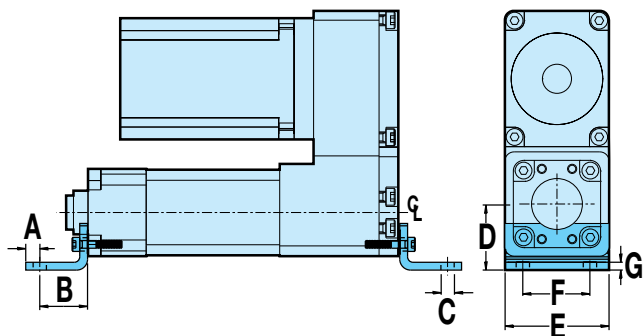

| Size | | A | B | C Ø | D | E | F | G |
|------|----|------|------|------|------|-------|------|------|
| 12 | in | 0.16 | 0.55 | 0.15 | 0.75 | 1.13 | 0.77 | 0.09 |
| | mm | 4.1 | 14.0 | 3.9 | 19.1 | 28.6 | 19.7 | 2.3 |
| 16 | in | 0.16 | 0.55 | 0.15 | 0.77 | 1.34 | 1.00 | 0.09 |
| | mm | 4.1 | 14.0 | 3.9 | 19.7 | 34.0 | 25.4 | 2.3 |
| 24 | in | 0.37 | 1.00 | 0.33 | 1.19 | 2.04 | 1.25 | 0.12 |
| | mm | 7.1 | 23.9 | 7.0 | 29.9 | 51.8 | 32.2 | 3.0 |
| 32 | in | 0.37 | 1.00 | 0.41 | 1.43 | 2.58 | 1.75 | 0.13 |
| | mm | 9.5 | 32.0 | 9.0 | 36.3 | 64.0 | 45.0 | 3.2 |
| 50 | in | 0.50 | 1.25 | 0.46 | 1.93 | 3.70 | 2.75 | 0.12 |
| | mm | 16.5 | 41.0 | 12.0 | 49.1 | 96.0 | 63.0 | 3.2 |
| 64 | in | 0.50 | 1.25 | 0.46 | 2.32 | 4.58 | 3.50 | 0.12 |
| | mm | 19.0 | 41.0 | 14.0 | 59.0 | 113.0 | 75.0 | 3.2 |

GSA Electric Rod-Style Actuator

SIZE: ALL

DIMENSIONS 3D CAD available at

C K & C K S STOP COLLARS



Provides a positive stop mechanism when required.

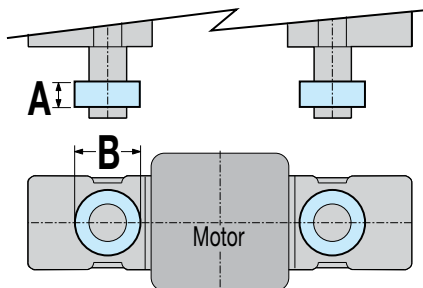

STANDARD GUIDE RODS

| Size | | A | B Ø |
|------|----|-------|-------|
| 12 | in | 0.406 | 1.125 |
| | mm | 10.31 | 28.58 |
| 16 | in | 0.438 | 1.313 |
| | mm | 11.13 | 33.35 |
| 24 | in | 0.500 | 1.500 |
| | mm | 12.70 | 38.10 |
| 32 | in | 0.500 | 1.750 |
| | mm | 12.70 | 44.45 |

OVERSIZED GUIDE RODS

| Size | | A | B Ø |
|------|----|-------|-------|
| 12 | in | 0.438 | 1.313 |
| | mm | 11.13 | 33.35 |
| 16 | in | 0.500 | 1.500 |
| | mm | 12.70 | 38.10 |
| 24 | in | 0.500 | 1.750 |
| | mm | 12.70 | 44.45 |
| 32 | in | 0.500 | 2.063 |
| | mm | 12.70 | 52.40 |

Sold & Serviced By:



Toll Free Phone (877) SERV098
Toll Free Fax (877) SERV099
www.electromate.com
sales@electromate.com

RSA & GSA Electric Rod-Style Actuator

SIZE: ALL

SWITCHES







RSA & GSA products offer a wide range of sensing choices. There are 12 switch choices: reed, solid state PNP (sourcing) or solid state NPN (sinking); in normally open or normally closed; with flying leads or quick-disconnect.

Commonly used for end-of-stroke positioning, these switches allow installation anywhere along the entire actuator length. The internal magnet is a standard feature. Switches can be installed in the field at any time.

Switches are used to send digital signals to PLC (programmable logic controller), TTL, CMOS circuit or other controller device. Switches contain reverse polarity protection. Solid state QD cables are shielded; shield should be terminated at flying lead end.

All switches are CE rated and are RoHS compliant. Switches feature bright red or yellow LED signal indicators; solid state switches also have green LED power indicators.

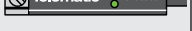

| | Order Code | Lead | Switching Logic | Power LED | Signal LED | Operating Voltage | **Power Rating (Watts) | Switching Current (mA max.) | Current Consumption | Voltage Drop | Leakage Current | Temp. Range | Shock / Vibration |
|-------------|-------------------|------|--------------------------------|---|------------|-------------------|------------------------|-----------------------------|---------------------|--------------|-----------------|---------------------------|-------------------|
| REED | R Y | 5m | SPST Normally Open | — | Red | 5 - 240 AC/DC | **10.0 | 100mA | — | 3.0 V max. | — | 14 to 158°F [-10 to 70°C] | 50 G / 9 G |
| | R K | QD* | |  | | | | | | | | | |
| | N Y | 5m | SPST Normally Closed | — | Yellow | 5 - 110 AC/DC | | | | | | | |
| | N K | QD* | |  | | | | | | | | | |
| SOLID STATE | T Y | 5m | PNP (Sourcing) Normally Open | Green | Yellow | 10 - 30 VDC | **3.0 | 100mA | 20 mA @ 24V | 2.0 V max. | 0.05 mA max. | | |
| | T K | QD* | |  | | | | | | | | | |
| | K Y | 5m | NPN (Sinking) Normally Open | Green | Red | | | | | | | | |
| | K K | QD* | |  | | | | | | | | | |
| | P Y | 5m | PNP (Sourcing) Normally Closed | Green | Yellow | | | | | | | | |
| | P K | QD* | |  | | | | | | | | | |
| | H Y | 5m | NPN (Sinking) Normally Closed | Green | Red | | | | | | | | |
| | H K | QD* | |  | | | | | | | | | |

*QD = Quick-disconnect Enclosure classification IEC 529 IP67 (NEMA 6)

CABLES: Robotic grade, oil resistant polyurethane jacket, PVC insulation

⚠️ **WARNING: Do not exceed power rating (Watt = Voltage x Amperage). Permanent damage to sensor will occur.

SWITCH INSTALLATION



Place switch bracket into one of the four slots that run the length of the extruded tube. Note that there is a cutout on the actuator head (RSA) or tube (GSA) to allow insertion of the bracket. Insert the switch with the word "Tolomatic" facing up and slide it under the bracket. Position the bracket with the switch to the exact location desired, then lock them securely into place by tightening both set screws on the bracket.

Sold & Serviced By:

 Toll Free Phone (877) SERV038
 Toll Free Fax (877) SERV099
www.electromate.com
sales@electromate.com

RSA & GSA Electric Rod-Style Actuator

SIZE: ALL

SWITCHES

WIRING DIAGRAMS

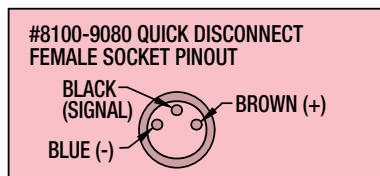
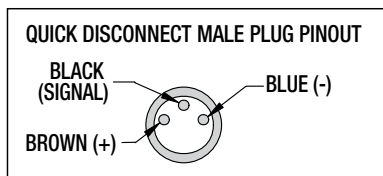
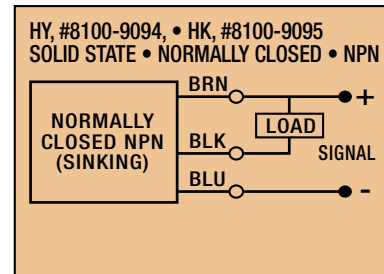
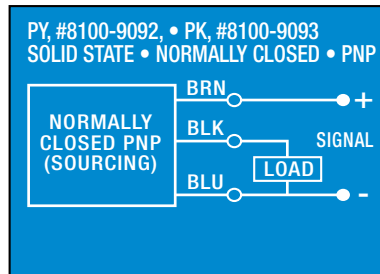
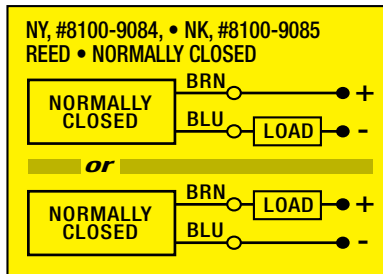
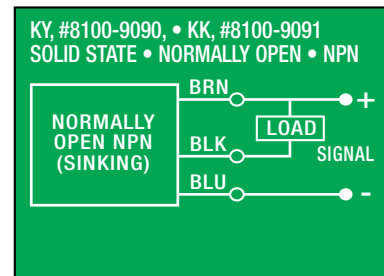
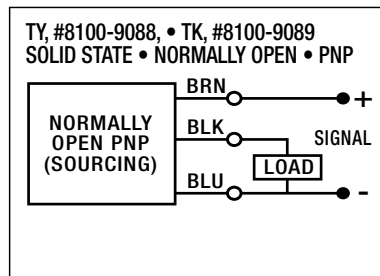
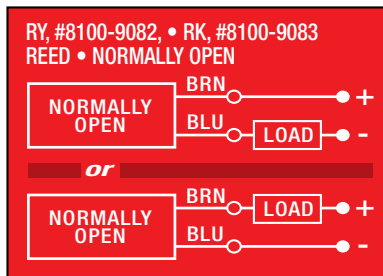

SWITCH DIMENSIONS

- direct connect

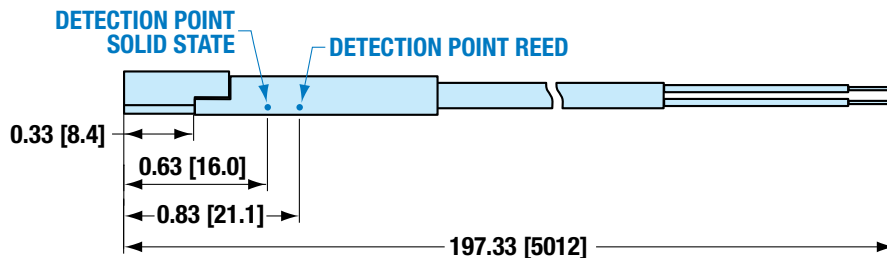

- QD (Quick-disconnect) switch

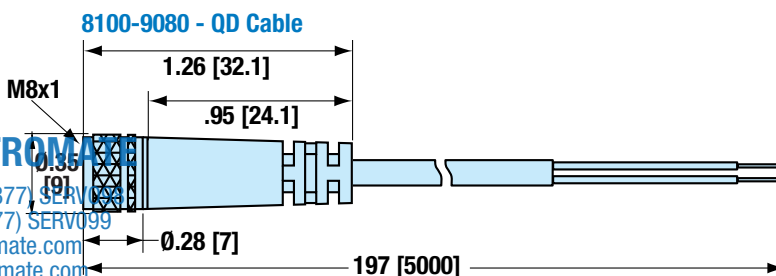
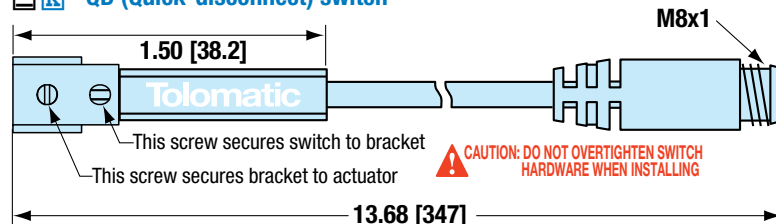

MOUNTING DIMENSIONS

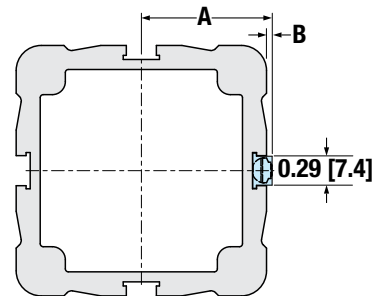

| Size | A | | B | |
|------|------|------|------|-----|
| | in | mm | in | mm |
| 12 | 0.68 | 17.2 | 0.13 | 3.3 |
| 16 | 0.77 | 19.6 | 0.11 | 2.9 |
| 24 | 1.06 | 26.9 | 0.06 | 1.5 |
| 32 | 1.31 | 33.2 | | |
| 50 | 1.87 | 47.5 | | |
| 64 | 2.31 | 58.6 | | |

Sold & Serviced By:



Toll Free Phone (877) SERV(99)
Toll Free Fax (877) SERV(99)
www.electromate.com
sales@electromate.com

APPLICATION DATA WORKSHEET

Fill in known data. Not all information is required for all applications

ORIENTATION

RSA

Horizontal

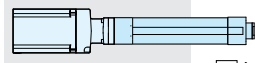

Vertical

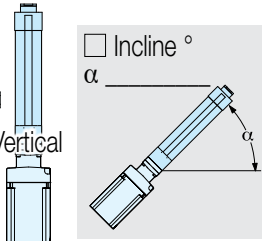

Incline °

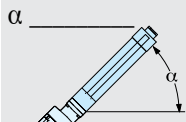

GSA

Horizontal

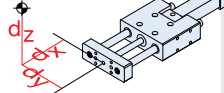

Horizontal Side

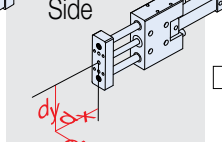

Vertical

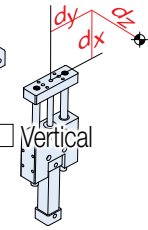

Incline °

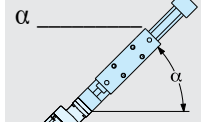

Load supported by actuator OR Load supported by other mechanism

MOVE PROFILE

EXTEND

Move Distance _____

inch (US Standard) millimeters (Metric)

Move Time _____ sec

Max. Speed _____

in/sec mm/sec

Dwell Time After Move _____ sec

RETRACT

Move Distance _____

inch millimeters

Move Time _____ sec

Max. Speed _____

in/sec mm/sec

Dwell Time After Move _____ sec

NO. OF CYCLES

per minute per hour

HOLD POSITION? Required

Not Required

After Move During Power Loss

NOTE: If load or force changes during cycle use the highest numbers for calculations

EXTEND

LOAD

lb. (U.S. Standard) kg. (Metric)

FORCE

lb. (U.S. Standard) kg. (Metric)

RETRACT

LOAD

lb. (U.S. Standard) kg. (Metric)

FORCE

lb. (U.S. Standard) kg. (Metric)

STROKE LENGTH

inch (US Standard)

millimeters (Metric)

DISTANCE FROM TOOLING PLATE TO LOAD CENTER OF GRAVITY*

inch

millimeters

NOTE: Use for GSA only, RSA requires external support and guidance for load

d_x _____

d_y _____

d_z _____

MOTION PROFILE

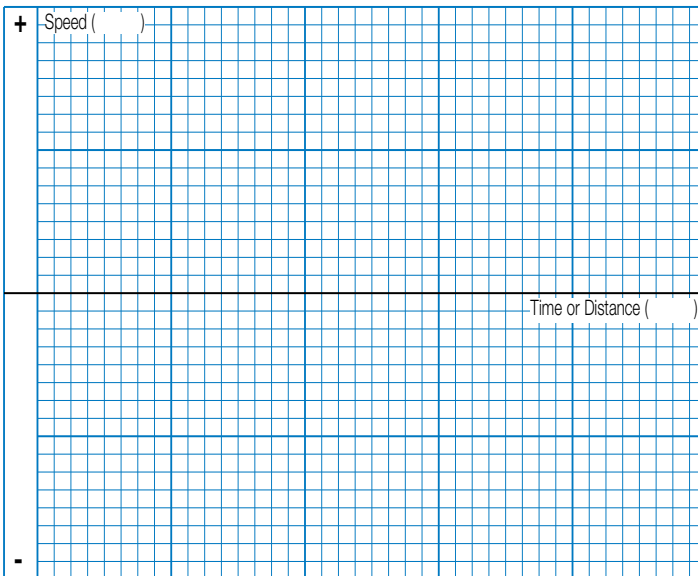

Graph your most demanding cycle, including accel/decel, velocity and dwell times. You may also want to indicate load variations and I/O changes during the cycle. Label axes with proper scale and units.

CONTACT INFORMATION

Name, Phone, Email
Co. Name, Etc.

Sold & Serviced By:



Toll Free Phone (877) SERV098

Toll Free Fax (877) SERV099

www.electromate.com

sales@electromate.com

RSA & GSA Electric Rod-Style Actuator

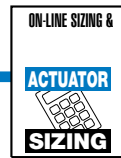

Selection Guidelines

1 ESTABLISH MOTION PROFILE

Using the application stroke length, desired cycle time, loads and forces, establish the motion profile details including linear velocity and thrust in each of its segments.

2 SELECT ACTUATOR TYPE

If side (radial) loads are present, select GSA.

3 SELECT ACTUATOR SIZE AND SCREW TYPE

Based on the required velocities and thrust select an actuator size and type and lead of screw drive.

4 VERIFY CRITICAL SPEED OF THE SCREW

Verify that the application's peak linear velocity does not exceed the critical speed value for the size and lead of the screw selected.

5 VERIFY AXIAL BUCKLING STRENGTH OF THE SCREW

Verify that the peak thrust does not exceed the critical buckling force for the size of the screw selected.

6 COMPARE APPLICATION'S PEAK PARAMETERS TO PEAK CAPACITY (PEAK REGION) OF SELECTED ACTUATOR (ROLLER SCREW)

When a roller screw is selected, calculate the application's required peak thrust and peak velocity and compare to the graphs on page R/GSA_12. The selection must satisfy the application's peak requirements.

7 COMPARE APPLICATION'S CONTINUOUS OPERATION PARAMETERS TO CONTINUOUS OPERATION CAPACITY (CONTINUOUS DUTY REGION) OF SELECTED ACTUATOR (ROLLER SCREW)

When a roller screw is selected, calculate the application's continuous operation thrust and velocity and compare to the graph on page R/GSA_12. The selection must satisfy the application's peak requirements.

8 CALCULATE LUBRICATION INTERVAL (ROLLER SCREW)

When a roller screw is selected, calculate the recommended lubrication interval. See page R/GSA_12 and parts sheets for complete lubrication information for the RSA24, RSA32 and RSA64.

9 TEMPERATURE CONSIDERATIONS

If the application's ambient temperature lies outside of the allowed range [roller screw: 50° to 122°F (10° to 50°C), all others 40° to 130°F (4° to 54°C), contact the factory. Note that in aggressive applications where roller screw is used, outside temperature of the actuator's body can approach 180°F (82°C), and adequate clearance to avoid overheating of other system components should be allowed.

10 ESTABLISH TOTAL TORQUE REQUIREMENTS

Calculate total system inertia, the peak and the RMS torque required from the motor to overcome internal friction, external forces and accelerate/decelerate the load.

11 SELECT A MOTOR AND A CONTROLLER

Use the obtained total torque value to select a motor and a reduction device (if required). Verify that the peak torque value is below the motor's peak torque curve, and that the continuous torque value is below the motor's continuous torque curve. Verify the minimum torque margin (15%). Verify the inertia match. Select a controller.

12 SELECT A MOTOR-ACTUATOR CONFIGURATION AND SENSORS IF REQUIRED

Select an inline or a reverse-parallel motor configuration. Select mounting and rod end options. Select position sensors (if required). 12 sensor choices include: reed, solid state PNP or NPN, all in normally open or normally closed, with flying leads or quick-disconnect couplers.

13 SELECT ROD END OPTIONS AND MOUNTING OPTIONS

Rod end options include: CLV clevis rod end, SRE spherical rod end, MET externally threaded rod end, ALC alignment coupler, XR rod extension. Mounting options include: TRN trunnion mount, FFG front flange mount, MP2 mounting plates, FM2 foot mount, PCD clevis mount, PCS eye mount, BFG back flange mount.

Sold & Serviced By:



The above guidelines are for reference only. Use Tolomatic online sizing software for best results.

Toll Free Phone (877) SERV098

Toll Free Fax (877) SERV099

www.electromate.com

sales@electromate.com

RSA & GSA Electric Rod-Style Actuator

SIZE: ALL

SERVICE PARTS ORDERING

RSA ACTUATOR MOUNTING REPLACEMENT KITS

| Code | Size | 12 | | 16 | | 24 | | 32 | | 50 | | 64ST | | 64HT | |
|-----------------------------------|--------------------|-------------|------------|---|-----------|-----------|-----------|-----------|-----------|-----------|-----------|-----------|-----------|-----------|-----------|
| | | Description | RSA | RSM | RSA | RSM | RSA | RSM | RSA | RSM | RSA | RSM | RSA | RSM | RSA |
| For all motor mounts | | | | | | | | | | | | | | | |
| FFG | Front Flange Mount | 1107-9013 | 2107-9013 | 1112-9013 | 2112-9013 | 1124-9022 | 2124-9032 | 1132-9022 | 2132-9042 | 1150-9022 | 2150-9042 | 1164-9022 | 2164-9022 | 1164-9384 | 2164-9384 |
| MP2 | Mounting Plate | 1107-9015 | 2107-9015 | 1112-9014 | 2112-9014 | 1124-9023 | 2124-9033 | 1132-9023 | 2132-9043 | 1150-9023 | 2150-9043 | 1164-9023 | 2164-9023 | 1164-9375 | 2164-9375 |
| | | 1112-9014* | 2112-9014* | *Mounting Plate with 23 frame motor or YMH Option (for RSA12 size only) | | | | | | | | | | | |
| For RP motor mounting only | | | | | | | | | | | | | | | |
| FM2 | Foot Mount | 1107-9010 | 2107-9009 | 1112-9010 | 2112-9010 | 1124-9020 | 2124-9030 | 1132-9020 | 2132-9040 | 1150-9020 | 2150-9040 | 1164-9020 | 2164-9020 | NA | NA |
| BFG | Back Flange Mount | 1107-9014 | 2107-9014 | 1112-9013 | 2112-9025 | 1124-9022 | 2124-9032 | 1132-9022 | 2132-9042 | 1150-9022 | 2150-9042 | 1164-9022 | 2164-9022 | 1164-9384 | 2164-9384 |
| PCS | Eye Mount | 1107-9016 | 2107-9016 | 1107-9016 | 2107-9016 | 1124-9024 | 2124-9034 | 1132-9024 | 2132-9044 | 1150-9024 | 2150-9044 | 1164-9024 | 2164-9024 | 1164-9344 | 2164-9344 |
| PCD | Clevis Mount | 1107-9017 | 2107-9017 | 1107-9017 | 2107-9017 | 1124-9025 | 2124-9035 | 1132-9025 | 2132-9045 | 1150-9025 | 2150-9045 | 1164-9025 | 2164-9025 | 1164-9345 | 2164-9345 |

⊗ FM2 Not available with HT option

RSA ROD END REPLACEMENT KITS

| Code | Size | 12 | | 16 | | 24 | | 32 | | 50 | | 64ST | | 64HT | |
|------|-------------------|-------------|-----------|-----------|-----------|-----------|-----------|-----------|-----------|-----------|-----------|-----------|-----------|-----------|-----------|
| | | Description | RSA | RSM | RSA | RSM | RSA | RSM | RSA | RSM | RSA | RSM | RSA | RSM | RSA |
| CLV | Clevis End | 1107-9021 | 2107-9021 | 1112-9020 | 2112-9020 | 1124-9029 | 2124-9039 | 1124-9029 | 2132-9049 | 1150-9029 | 2150-9049 | 1150-9029 | 2164-9029 | 1164-9386 | 2164-9386 |
| SRE | Spherical Rod Eye | 1107-9020 | 2107-9020 | 1112-9019 | 2112-9019 | 1124-9028 | 2124-9038 | 1124-9028 | 2132-9048 | 1150-9028 | 2150-9048 | 1150-9028 | 2164-9028 | 1164-9028 | 2164-9387 |
| MET | External Threaded | 1107-1073 | 2107-1073 | 1112-1058 | 2112-1058 | 1124-1057 | 2124-1067 | 1124-1057 | 2132-1057 | 1150-1057 | 2150-1057 | 1150-1057 | 2164-1057 | 1164-1035 | 2164-1546 |
| ALC* | Alignment Coupler | 1107-1076 | NA | 1112-1065 | NA | 1124-9004 | 2124-1070 | 1124-9004 | 2132-1060 | 1150-9009 | 2150-1060 | 1150-9009 | 2164-1060 | 1164-9385 | 2164-1060 |

📖 *NOTE: Alignment coupler is internally threaded, if external thread is desired order MET also

NA = Not Available

GSA OPTIONS REPLACEMENT KITS

| Description | SIZE | | | |
|-----------------------------|-----------|-----------|-----------|-----------|
| | 12 | 16 | 24 | 32 |
| Stop Collar | 2312-1005 | 2317-1005 | 2334-1005 | 2332-1005 |
| Stainless Steel Stop Collar | 2312-1056 | 2317-1056 | 2324-1056 | 2332-1056 |

| Description | SIZE | | | |
|--|-----------|-----------|-----------|-----------|
| | 12 | 16 | 24 | 32 |
| Over-Sized Stop Collar | 2317-1005 | 2324-1005 | 2332-1005 | 2348-1005 |
| Stainless Steel Over-Sized Stop Collar | 2317-1056 | 2324-1056 | 2332-1056 | 2348-1056 |

📖 Kits include one collar and required fasteners

RSA & GSA SWITCHES

To order switch kit use configuration code for switch preceded by SW and actuator code.

EXAMPLE: **SW** **RSA** **24** **KK**

K
I
T
S
W
R
S
A
2
4
K
K

KIT ACTUATOR SIZE SWITCH CODE

The example is for Solid State NPN, Normally Open Switch with Quick-disconnect couplers. Each switch kit is complete with Bracket, Set Screw, Switch and mating QD cable. Note that the bracket/switch size is common and may be used on any size RSA.

| Code | Switch & Bracket Part No. | **Switch ONLY Part No. | Lead | Normally | Sensor Type |
|-------------------|---------------------------|------------------------|------------------|----------|-----------------|
| R Y | 8100-9282 | 8100-9082 | 5m (197 in) | Open | Reed |
| R K | 8100-9283* | 8100-9083* | Quick-disconnect | | |
| N Y | 8100-9284 | 8100-9084 | 5m (197 in) | Closed | Reed |
| N K | 8100-9285* | 8100-9085* | Quick-disconnect | | |
| T Y | 8100-9288 | 8100-9088 | 5m (197 in) | Open | Solid State PNP |
| T K | 8100-9289* | 8100-9089* | Quick-disconnect | | |
| K Y | 8100-9290 | 8100-9090 | 5m (197 in) | Open | Solid State NPN |
| K K | 8100-9291* | 8100-9091* | Quick-disconnect | | |
| P Y | 8100-9292 | 8100-9092 | 5m (197 in) | Closed | Solid State PNP |
| P K | 8100-9293* | 8100-9093* | Quick-disconnect | | |
| H Y | 8100-9294 | 8100-9094 | 5m (197 in) | Closed | Solid State NPN |
| H K | 8100-9295* | 8100-9095* | Quick-disconnect | | |

**Also order bracket with set screw #1124-9007

*Also order mating QD cable #8100-9080

Sold & Serviced By:

ELECTROMATE see part number in table at right

Toll Free Phone (877) SERV098
Toll Free Fax (877) SERV099

NOTE: Refer to parts sheets to replace switches on actuators manufactured before 5-10-2010.

RSA & GSA Electric Rod-Style Actuator



ORDERING

ACTUATOR

RSA 50 BN02 SK35

MODEL & MOUNTING

- RSA** Rod-Style Screw-Drive Actuator, inch mounting
- RSM** metric mounting
- GSA** Guided Screw-Drive Actuator, inch mounting
- GSM** metric mounting

SIZE

12, 16, 24, 32, 50*, 64*

⊗ *GSA not available in 50 or 64 size

NUT/SCREW COMBINATIONS

| SIZE | CODE | TURNS/in (TPI) |
|------|---------|----------------|
| 12 | SN | 01,02,05 |
| | BZ | 10 |
| | BN, BNL | 08 |
| 16 | SN | 01,02,05 |
| | BZ | 10 |
| | BN, BNL | 08 |
| 24 | SN | 02,04,08 |
| | BZ | 10 |
| | BN,BNL | 02,05 |
| | RN* | 05,10 |
| 32 | SN | 01,02 |
| | BZ | 10 |
| | BN,BNL | 02,05 |
| | BNM | 20 |
| 50 | SN | 04 |
| | BZ | 10 |
| | BN,BNL | 01,02,04 |
| | BNM | 05,10,25 |
| 64 | SN | 04 |
| | BZ | 10 |
| | BN,BNL | 02,04,53 |
| | BNM | 05,10,20 |
| | BNH | 02 |
| | RN | 05 |

⊗ *RN is Non-standard for GSA/GSM

STROKE LENGTH

SK ___ Enter desired stroke length in decimal inches

MAXIMUM STROKE

| SIZE | RSA | | GSA | |
|------|-----|--------|-----|-------|
| | in | mm | in | mm |
| 12 | 18 | 457.2 | 18 | 457.2 |
| 16 | 18 | 457.2 | 24 | 609.6 |
| 24 | 24 | 609.6 | 30 | 762.0 |
| 32 | 36 | 914.4 | 36 | 914.4 |
| 50 | 48 | 1219.2 | | |
| 64 | 60 | 1524.0 | | NA |

OPTIONS

RP1 ST1 TRR FFG XR6 ALC MET KK2 YM

MOTOR MOUNTING

- LMI** In-line motor mount
- RP1** 1:1 ratio, reverse parallel motor mount
- RP2** 2:1 ratio, reverse parallel motor mount

⊗ RP2 not available on 12 or 16 size

STANDARD OR HIGH TORQUE

- ST1** Standard RS Actuator
- HT1*** High Torque Option
- HT2*** High Torque Roller Screw Opt. *requires keyed motor

⊗ HT not available on 12, 16 or 24 size

BEARINGS & GUIDE RODS (GSA ONLY)

- LB** Linear Bearings*
- CB** Composite Bearings, Standard Size Rods
- COB** Composite Bearings, Over Sized Rods
- CBS** Composite Bearings, Standard Size Stainless Steel Rods
- CBSO** Composite Bearings, Over-Sized Stainless Steel Rods

⊗ *Stainless steel guide rods not available with Linear Bearings

STOP COLLAR (GSA ONLY)

- CK** Steel Stop Collar
- CKS** Stainless Steel Stop Collar

NOTE: The correct Stop Collar will be automatically chosen based on the bearing and guide rod previously selected.

TRUNNION MOUNT (RSA ONLY)

- TRR** Trunnion mount

⊗ Not available on 12 or 16 size with LMI motor mount
NOTE: Trunnion mount is not available for field retrofit, contact Tolomatic for details

IP67 (RSA32, 50, 64 ONLY)

- IP67** Basic ingress protection

NOTE: *HT actuator (LMI & RP); ST actuator (RP motor mount only)

ACTUATOR MOUNTING (RSA ONLY)

For all motor mounts:

- FFG** Front Flange Mount
- MP2** Mounting Plates (2 required)

For RP motor mounting only:

- FM2*** Foot Mount (2 required)
- PCD** Clevis Mount
- PCS** Eye Mount
- BFG** Back Flange Mount

⊗ *FM2 not available with HT option

ROD EXTENSION (RSA ONLY)

XR ___ Enter desired rod extension in decimal inches

▲ For vertical applications only.

NOTE: The XR extension + stroke should not exceed the max. stroke of the specified actuator. (See MAX. STROKE table) Consult Tolomatic for extensions greater than the max. stroke length.

ROD END (RSA ONLY)

Internally threaded rod end is standard

- CLV** Clevis Rod End
- SRE** Spherical Rod End
- MET** Externally Threaded Rod End
- ALC** Alignment Coupler Rod End*

NOTE: Alignment coupler is internally threaded, if external thread is desired order MET also

SWITCHES

| | TYPE | LOGIC | NORMALLY | QUICK-DISCONNECT | CODE | QUANTITY | LEAD LENGTH |
|-------------|------|--------|----------|------------------|-----------------------------------|----------------------|-------------|
| REED | SPST | Open | no | RY | After code enter quantity desired | 5 meters (16.4 feet) | |
| | | | yes | RK | | | |
| SOLID STATE | PNP | Open | no | TY | | | |
| | | | yes | TK | | | |
| SOLID STATE | NPN | Open | no | KY | | | |
| | | | yes | KK | | | |
| SOLID STATE | PNP | Closed | no | PY | | | |
| | | | yes | PK | | | |
| SOLID STATE | NPN | Closed | no | HY | | | |
| | | | yes | HK | | | |

YOUR MOTOR HERE

YM ___ Motor mount for third party motor

Sold & Served By: **ELECTROMATE**

Toll Free Phone: 1-800-451-1000
Toll Free Fax: 1-800-451-1001
www.electromate.com
sales@electromate.com

ACTUATOR

Use Tolomatic On-line Sizing & Selection to determine available options and accessories based on your application requirements

The Tolomatic Difference Expect More From the Industry Leader:



INNOVATIVE PRODUCTS

Tolomatic designs and builds the best standard products, modified products & unique custom products for your challenging applications.



FAST DELIVERY

The fastest delivery of catalog products... Electric products are built-to-order in 15 days; Pneumatic & Power Transmission products in 5 days.



ACTUATOR SIZING

Online sizing that is easy to use, accurate and always up-to-date. Find a Tolomatic electric actuator to meet your requirements.



YOUR MOTOR HERE

Match your motor with compatible mounting plates that ship with any Tolomatic electric actuator.



LIBRARY

Easy to access CAD files available in the most popular formats to place directly into your assembly.



SUPERIOR SERVICE

Our people make the difference! Expect prompt, courteous replies to all of your application and product questions.

Also Consider These Other Tolomatic Products:

Electric Products

Rod & Guided Rod Style Actuators, High Thrust Actuators, Screw & Belt Drive Rodless Actuators, Motors, Drives and Controllers

"Foldout" Brochure #9900-9074



Pneumatic Products

Rodless Cylinders: Band Cylinders, Cable Cylinders, Magnetically Coupled Cylinders/Slides; Guided Rod Cylinder Slides

"Foldout" Brochure #9900-9075



Power Transmission Products

Gearboxes: Float-A-Shaft®, Slide-Rite®; Disc Cone Clutch; Caliper Disc Brakes

"Foldout" Brochure #9900-9076



Sold & Serviced By:



Toll Free Phone (877) SERV098

Toll Free Fax (877) SERV099

www.tolomatic.com

sales@tolomatic.com

All brand and product names are trademarks or registered trademarks of their respective owners. Information in this document is believed accurate at time of printing. However, Tolomatic assumes no responsibility for its use or for any errors that may appear in



this document. Tolomatic reserves the right to change the design or operation of the equipment described herein and any associated motion products without notice. Information in this document is subject to change without notice.