

IMA

INTEGRATED MOTOR ROD-STYLE ACTUATOR

 **ENDURANCE TECHNOLOGY**™

Patented



Sold & Serviced By:

 **ELECTROMATE**

Toll Free Phone (877) SERV098
Toll Free Fax (877) SERV099
www.electromate.com
sales@electromate.com

The longest lasting, high-force integrated actuator on the market!

The IMA is a compact, durable, high force rod-style actuator. The IMA integrates a servo motor into a ball or roller screw-driven actuator to provide efficient high force in a compact lightweight design envelope. Our patented* design allows for easy re-lubrication without disassembly for extremely long service life.



Tolomatic has over 50 years of experience manufacturing rodless and rod-style electric and pneumatic actuators. The IMA combines this experience and the power of servo motor technology into one actuator. The result: reliable, affordable power in a compact package.

*U.S. PATENT NO. 8,196,484

The IMA's unique integrated design

Features:

- Compact, lightweight design
- Long life
- High force
- High positional accuracy
- High efficiency
- Proven performance
- Ratings for extreme environments
- Compatibility
- Low inertia



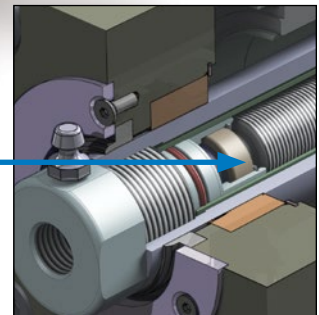

Eliminates:

- Couplers
- Adapters
- Belts
- Gears
- Unneeded assembly labor
- Forced air or water cooling
- Hydraulic systems
- Pneumatic systems
- Need for multiple vendors

**SCREW
LUBRICATION
SYSTEM FOR
EXTENDED
SERVICE LIFE**



TOLOMATIC'S ELECTRIC ROD-STYLE ACTUATORS

	ERD	ICR	RSA	GSA	IMA
					
	Rod-Style Actuator	Integrated Control Rod-Style Actuator	Rod-Style Actuator	Guided Rod-Style Actuator	Integrated Motor Rod-Style Actuator
Thrust up to:	4,500 lbf [20,017 N]	720 lbf [3,202.7 N]	13,039 lbf [58,001 N]	950 lbf [4,226 N]	6,875 lbf [30,594 N]
Speed up to:	58 in/sec [1473 mm/sec]	25 in/sec [635 mm/sec]	123 in/sec [3,124 mm/sec]	123 in/sec [3,124 mm/sec]	52.5 in/sec [1,334 mm/sec]
Stroke Length up to:	39.4 in [1000 mm]	24 in [609 mm]	60 in [1,524 mm]	36 in [914 mm]	18 in [457 mm]
Screw/Nut Type	Solid, Ball & Roller	Ball	Solid, Ball & Roller	Solid & Ball	Ball & Roller
	<i>For complete information see</i>			<i>or literature number:</i>	
	2190-4000	2100-4000	3600-4609	3600-4609	2700-4000

(Not all models deliver maximum values listed, i.e.: Maximum thrust may not be available with maximum speed)

IMA - Integrated Motor Actuator

IMA Applications

Press Fitting System

- High Force
- Long Life



Valve / Process Control

- Efficient
- Accurate Positioning
- Quick Response

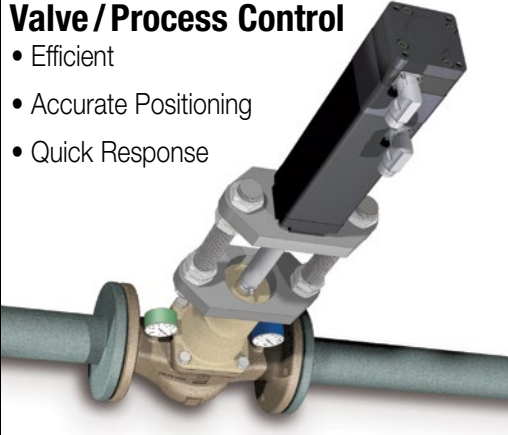

CONTENTS

- What is the IMA? 2
- IMA Applications 3
- IMA Features 4
- IMA Specs & Performance 8-14
- IMA Dimensions 15-18
- Application Data Worksheet 19
- Selection Guidelines 20
- Ordering 23

Fluid Dispensing

- Repeatabile Force
- Smooth Velocity



Spot Welding

- Compact, Lightweight
- Repeatabile, High Force

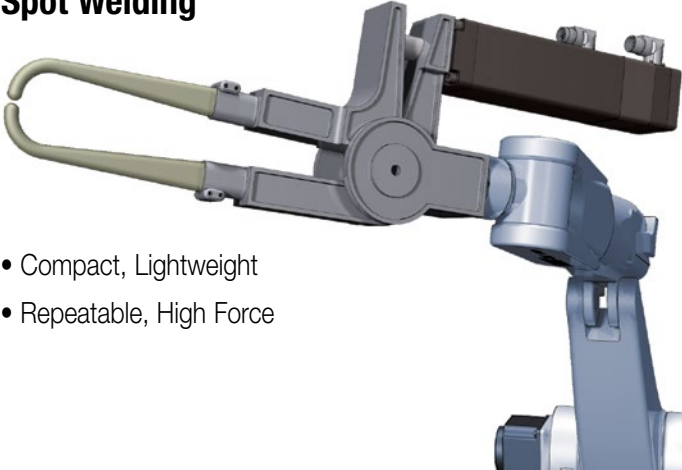

More Applications:

- | | | | |
|--|---|---|---|
| <ul style="list-style-type: none"> • Aerospace • Animation • Assembly • Automated assembly • Automatic tool changers • Automotive • Clamping • Converting • Converters • Cycle testing • Filers | <ul style="list-style-type: none"> • Formers • Hydraulic replacement • Laser positioning • Machine tools • Material handling systems • Medical equipment • Military • Molding • Motion simulators • Open/close doors • Packaging equipment | <ul style="list-style-type: none"> • Parts clamping • Patient lifts • Pick & place • Pneumatic replacement • Precision grinders • Product test simulations • Riveting / fastening / joining • Robot manipulator arms • Sawmill equipment | <ul style="list-style-type: none"> • Semiconductor • Stamping • Table positioning • Tension control • Test stands • Tube bending • Volumetric pumps • Water jet control • Wave generation • Web guidance • Welding • Wire winding |
|--|---|---|---|

IMA INTEGRATED MOTOR ACTUATOR

ENDURANCE TECHNOLOGYSM

Endurance Technology features are designed for maximum durability to provide extended service life.

The IMA is a compact, durable, high force rod-style actuator. The IMA integrates a servo motor into a ball or roller screw-driven actuator to provide efficient high force in a compact lightweight design envelope. Our patented design allows for easy re-lubrication without disassembly for extremely long service life. Built-to-order in stroke lengths up to 18 inches with your choice of screw technology.

MULTIPLE SCREW TECHNOLOGIES YOU CAN CHOOSE:

- Ball nuts offer efficiency at a cost effective price
- Roller nuts provide the highest thrust and life ratings available



HIGH POSITIONAL ACCURACY

SCREW ACCURACY

Roller Nut ± 0.0004 "/ft. ± 0.0102 mm/300mm

Ball Nut ± 0.002 "/ft. ± 0.051 mm/300mm

INTERNAL BUMPERS

- Bumpers protect the screw and nut assembly from damage at end of stroke

REPLACEABLE ROD WIPER

- Prevents contaminants from entering the actuator for extended life

GREASE PORT

- Screw re-lubrication system provides extended screw service life
- Convenient lubrication without disassembly (IMA22 is lubed for life and does not include grease port)

INTEGRAL MOUNTING

- Four metric threaded holes on front face are available for direct mounting or addition of customized options

THREADED ROD END

- Zinc plated alloy steel construction for corrosion resistance
- Provides a common interface to multiple rod end options

THRUST TUBE

- Steel thrust tube supports extremely high force capabilities
- Salt bath nitride treatment provides excellent corrosion resistance, surface hardness and is very resistant to adherence of weld slag, water and other potential contaminants

LIGHTWEIGHT ALUMINUM DESIGN

- Black anodized extrusion design is optimized for rigidity and strength

Sold & Serviced By:

 **ELECTROMATE**

Toll Free Phone (877) SERV098

Toll Free Fax (877) SERV099

www.electromate.com

sales@electromate.com

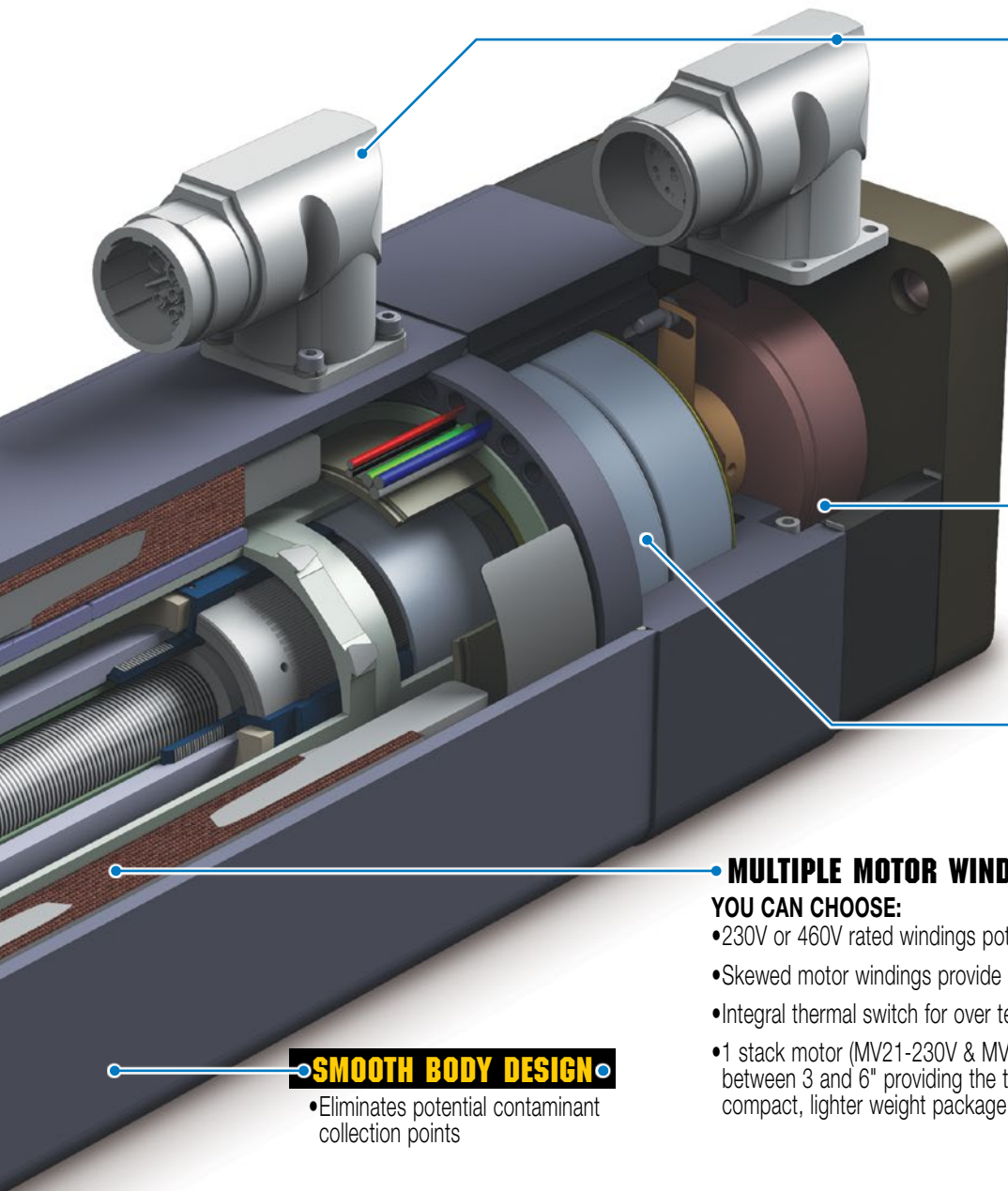

CONNECTORS YOU CAN CHOOSE FROM:

- Connector choice and wiring emulates popular motor manufacturers for compatibility:
 - Tolomatic Standard
 - Allen Bradley MP Series
 - Bosch Rexroth MSK Series
 - Emerson FM & NT Series
 - Lenze MCA Series
 - Others (see page 21)
- STAGGERED CONNECTORS for convenient installation
- 270° Rotatable & Box mount options available

HIGH RESOLUTION FEEDBACK YOU CAN CHOOSE:

- Digital encoder
- Multi-turn absolute encoder
- Resolver

HIGH THRUST BEARING

- Provides complete support of screw and protects the feedback device from linear forces

MULTIPLE MOTOR WINDINGS

YOU CAN CHOOSE:

- 230V or 460V rated windings potted directly into actuator housing
- Skewed motor windings provide minimal torque ripple for smooth linear motion
- Integral thermal switch for over temperature protection
- 1 stack motor (MV21-230V & MV41-460V) available for the IMA33, allows strokes between 3 and 6" providing the thrust needed for many applications in a more compact, lighter weight package

SMOOTH BODY DESIGN

- Eliminates potential contaminant collection points

OPTIONS

MOUNTING

- Front Face - Standard
- Side Mounting Holes, 2 sides & bottom (no photo)
- Mounting Plates
- Rear Clevis
- Front Flange
- Trunnion, Rear or Front

ROD END

- Internal Thread - Standard
- External Threads
- Clevis
- Spherical Eye
- Alignment Coupler

BRAKE

- 24V Spring held / electronically released

CABLES

- Signal Cable (6m)
- Power Cable (6m)

- IP67 For protection against water and dust ingress

- ARO • Anti-Rotate



Modifications:

- Contact Tolomatic for stainless steel, manual override, food grade or mil-spec versions of the IMA (See the white epoxy IMA on the next page)

FOOD GRADE IMA

ENDURANCE TECHNOLOGYSM

Endurance Technology features are designed for maximum durability to provide extended service life.

The standard production IMA is a highly capable actuator with an environmental rating of IP65. Yet the world of industrial automation places actuators in increasingly challenging environments. The white epoxy IMA has all the features of the IMA shown on the previous pages plus these features that are suited to challenging environments.

IP 67 RATED

- Static tested against ingress of dust and water for protection of internal components and long actuator life

300 SERIES STAINLESS STEEL ROD

- Corrosion resistant 316 stainless steel thrust rod

GREASE PORT

- Pictured with plug, grease zerk also available. Both made with corrosion resistant 316 stainless steel. Replace plug with zerk to lubricate
- Screw relubrication system provides extended screw service life
- Convenient lubrication without disassembly (IMA22 is lubed for life and does not include grease port)

FIELD SERVICEABLE VITON® WIPER

- State-of-the-art wiper prevents contaminants from entering the actuator for extended life

300 SERIES STAINLESS STEEL FASTENERS

- For corrosion resistance even if white epoxy is removed
- Hex bolts for fewer collection points for contaminants in wash-down environments

Sold & Serviced By:



Toll Free Phone (877) SERV098
Toll Free Fax (877) SERV099
www.electromate.com
sales@electromate.com

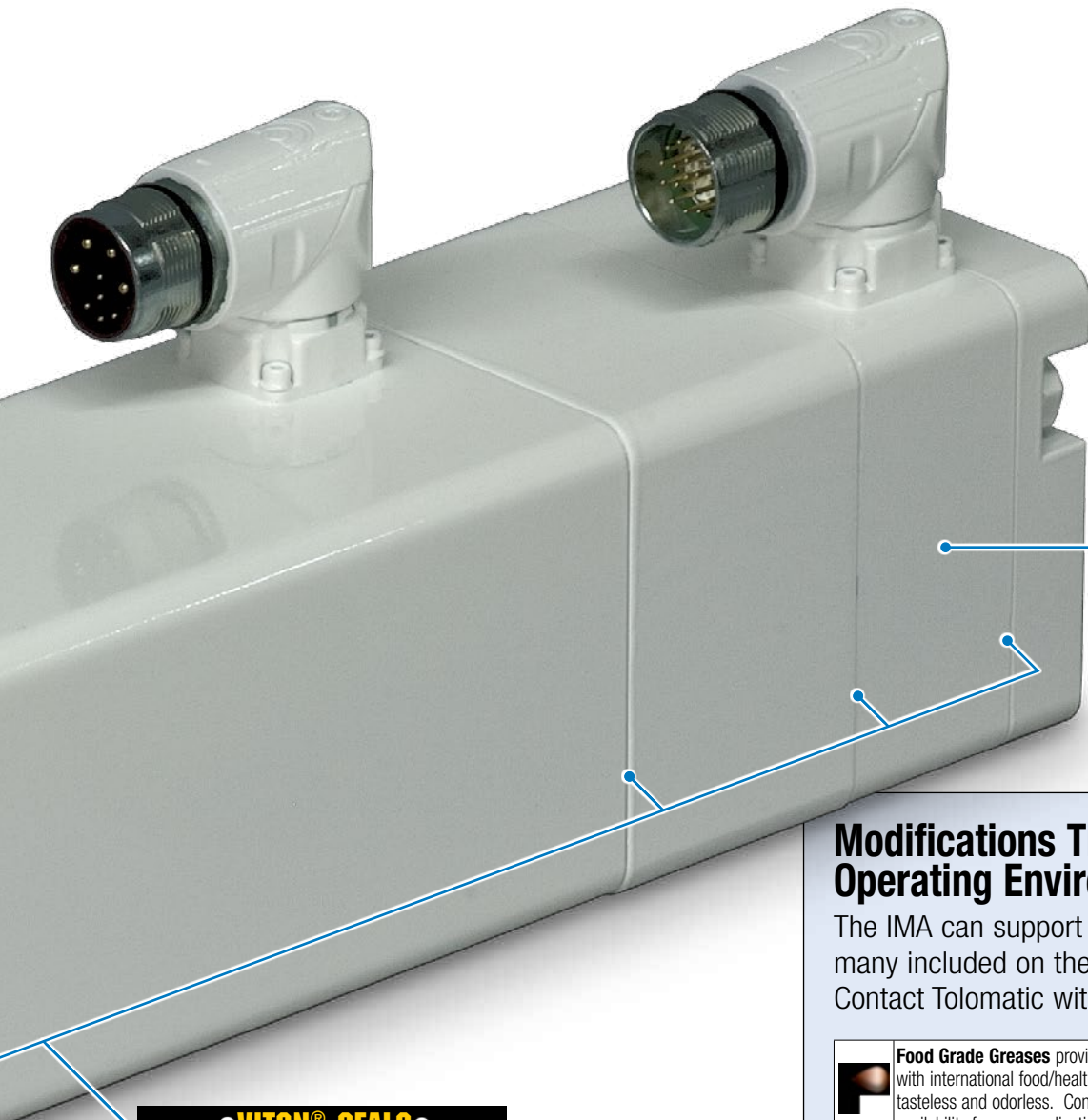

SMOOTH BODY DESIGN







- Fewer collection points for contaminants in wash-down environments

VITON® SEALS

- Viton®, a high performance elastomer, has a proven reputation for outstanding performance in hot and corrosive environments.

Modifications That Expand the Operating Environment of the IMA

The IMA can support the following modifications, many included on the white epoxy IMA featured. Contact Tolomatic with your requirements.

	Food Grade Greases provide the lubrication actuators require and comply with international food/health & safety regulations. They are nontoxic, inert, tasteless and odorless. Contact Tolomatic for specific grease options and availability for your application.
	Stainless Steel Fasteners for all external assembly and mounting on the IMA actuator.
	Stainless Steel Exterior Components provide corrosion resistance and may change the overall shape and external design of the Tolomatic actuator. Contact Tolomatic to determine the type of stainless steel to be used based on the application environment.
	Food-grade White Epoxy Paint applied to all external components for corrosion resistance. Contact Tolomatic for the best corrosion resistant option for the application environment.
	Purge Port: Through this port air is added into the Tolomatic electric actuator. Positive air pressure exhausts air out through the small entry points, minimizing the potential of particulate ingress into the actuator.
	IP67: INGRESS PROTECTION: FIRST DIGIT = Solids, 6 = Dust Tight (No ingress of dust; complete protection against contact) SECOND DIGIT = Liquids, 7 = Immersion up to 1 m (Ingress of water in harmful quantity shall not be possible when the enclosure is immersed in water under defined conditions of pressure and time up to 1 m of submersion).
	IP69K: INGRESS PROTECTION: German standard DIN 40050-9 extends the IEC 60529 rating system described above with an IP69K rating for high-pressure, high-temperature wash-down applications.[4] Such enclosures must not only be dust tight (IP6X), but also able to withstand high-pressure and steam cleaning.

OPTIONS

MOUNTING

- Front Face - Standard
- Side Mounting Holes
- 2 Sides & bottom
- Rear Clevis
- Front Flange
- Trunnion, Rear or Front



Sold & Serviced By:
 **ELECTROMATE**
 Toll Free Phone: (877) SERV098
 Toll Free Fax: (877) SERV099
 www.electromate.com
 sales@electromate.com

IMA - Integrated Motor Actuator

Performance & Mechanical Specifications:

SERIES	NUT/SCREW	IMA22	IMA22	IMA33 (1 Stack, MV21/41)					IMA33 (3 Stack, MV23/43)				
		(1 Stack, MV21/41)	(3 Stack, MV23/43)	BN05	BN10	BN20	RN05	RN10	BN05	BN10	BN20	RN05	RN10
SCREW LEAD	in	0.197	0.197	0.197	0.394	0.788	0.197	0.394	0.197	0.394	0.788	0.197	0.394
	mm	5	5	5	10	20	5	10	5	10	20	5	10
DYNAMIC LOAD RATING (1 mil revs)	lbf	1,286	1,286	1,958	1,214	2,560	10,211	6,805	1,958	1,214	2,560	10,211	6,805
	N	5,720	5,720	8,710	5,400	11,387	45,421	30,270	8,710	5,400	11,387	45,421	30,270
CONT. THRUST	lbf	200	325	365	183	92	350	175	900	450	225	850	425
	N	890	1,446	1,624	814	409	1,557	778	4,003	2,002	1,001	3,781	1,891
PEAK THRUST	lbf	325	325	1,000	549	276	1,050	525	1,000	900	675	1,700	850
	N	1,446	1,446	4,448	2,442	1,228	4,671	2,335	4,448	4,003	3,003	7,562	3,781
MAX. VELOCITY	in/sec	14	14	12	24	48	12	24	11.5	23	46	11.5	23
	mm/sec	356	356	305	610	1,219	305	610	292	584	1,168	292	584
**BASE INERTIA	lb-in ²	0.3078	0.5078	0.9464	0.9537	1.0253	0.9525	0.9618	1.6645	1.6717	1.7832	1.6723	1.6815
	kg-cm ²	0.9007	1.4859	2.7696	2.7908	3.0003	2.7874	2.8145	4.8709	4.8922	5.2184	4.8937	4.9208
INERTIA PER UNIT OF STROKE	lb-in ² /in	0.00123	0.00123	0.00266	0.00313	0.01211	0.00358	0.00413	0.00266	0.00313	0.01211	0.00358	0.00413
	kg-cm ² /mm	0.00014	0.00014	0.00031	0.00036	0.00140	0.00041	0.00048	0.00031	0.00036	0.00140	0.00041	0.00048
BREAKAWAY TORQUE	in-lb	3.0	3.0	4.8	4.8	4.8	5.3	5.3	4.8	4.8	4.8	5.3	5.3
	N-m	0.34	0.34	0.54	0.54	0.54	0.60	0.60	0.54	0.54	0.54	0.60	0.60
BACK DRIVE FORCE*	lbf	49	49	78	39	20	78	39	78	39	20	78	39
	N	218	218	347	173	89	347	173	347	173	89	347	173

SERIES	NUT/SCREW	IMA44					IMA55				
		BN05	BN10	BN25	RN05	RN10	BN05	BN10	BN20	RN05	RN10
SCREW LEAD	in	0.197	0.394	0.985	0.197	0.394	0.197	0.394	0.788	0.197	0.394
	mm	5	10	25	5	10	5	10	20	5	10
DYNAMIC LOAD RATING (1 mil revs)	lbf	4,035	3,372	2,537	12,703	12,703	6,714	7,476	5,528	21,973	11,750
	N	17,949	15,000	11,285	56,506	56,506	29,865	33,255	24,590	97,741	52,288
CONT. THRUST	lbf	1,750	875	350	1,650	825	2,950	1,475	738	2,750	1,375
	N	7,784	3,892	1,557	7,340	3,670	13,128	6,564	3,283	12,238	6,119
PEAK THRUST	lbf	2,000	1,750	700	3,300	1,650	3,000	2,950	1,845	6,875	2,750
	N	8,896	7,784	3,114	14,679	7,340	13,350	13,128	8,207	30,594	12,238
MAX. VELOCITY	in/sec	11.5	23	52.5	11.5	23	7.9	15.7	31.4	7.9	15.7
	mm/sec	292	584	1,334	292	584	201	399	797	201	399
**BASE INERTIA	lb-in ²	3.4193	3.4329	3.5276	3.3442	3.3602	26.6260	26.6684	26.8318	26.1949	26.2425
	kg-cm ²	10.0063	10.0459	10.3231	9.7864	9.8334	77.9185	78.0428	78.5208	76.6569	76.7962
INERTIA PER UNIT OF STROKE	lb-in ² /in	0.01811	0.01872	0.02303	0.00984	0.01056	0.15246	0.15385	0.15939	0.11051	0.11204
	kg-cm ² /mm	0.00209	0.00216	0.00265	0.00113	0.00122	0.01757	0.01773	0.01836	0.01273	0.01291
BREAKAWAY TORQUE	in-lb	5.6	5.6	5.6	6.2	6.2	9.4	9.4	9.4	10.3	10.3
	N-m	0.63	0.63	0.63	0.70	0.70	1.06	1.06	1.06	1.16	1.16
BACK DRIVE FORCE*	lbf	91	46	18	91	46	153	77	38	152	76
	N	405	205	80	405	205	681	343	169	676	338

Sold & Serviced By:



Toll Free Phone (877) 537-9098 Performance data was validated using an aluminum face mount plate: IMA22/33 (8.25" x 7.0" x 0.7"); IMA44 (9.0" x 9.0" x 0.7"); IMA55 (9.0" x 9.0" x 1.0")

Toll Free Fax (877) 537-9099 In vertical applications an unpowered IMA will require a brake to maintain position if the load on the actuator exceeds this value

www.electromate.com Value given is for a zero stroke actuator † To be determined, visit www.tolomatic.com for up-to-date information

sales@electromate.com

IMA - Integrated Motor Actuator

Performance & Mechanical Specifications:

SERIES		IMA22 (1 Stack, MV21/41)	IMA22 (3 Stack, MV23/43)	IMA33 (1 Stack, MV21/41)	IMA33 (3 Stack, MV23/43)	IMA44	IMA55
FACE SIZE	in	2.5		3.3		4.4	5.6
	mm	63.5		83		110	142
STROKE	in	3.0 to 12.0	6.0 to 12.0	3.0 to 18.0	6.0 to 18.0		6.0 to 18.0
	mm	76.2 to 304.8	152.4 to 304.8	76.2 to 457.2	152.4 to 457.2		152.4 to 457.2
**BASE WEIGHT	lb	5.3	6.4	11.4	14.1	28.6	54.5
	kg	2.4	2.9	5.2	6.4	13	24.8
WEIGHT PER UNIT OF STROKE	lb/in	0.2428		0.6603		1.1035	2.1115
	kg/mm	0.0073		0.0118		0.0197	0.03771
SCREW LEAD ACCURACY	BN	in/ft = 0.002 mm/300 = 0.051 (0.004 in/ft FOR IMA33BN20 AND IMA44BN25)					
	RN	in/ft = 0.0004 mm/300 = 0.0102					
SCREW LEAD BACKLASH	BN	in = 0.004 mm = 0.1					
	RN	in = 0.0012 mm = 0.03					
TEMP RANGE	°F	50 to 104 (Contact Tolomatic if higher temperature is required)					
	°C	10 to 40 (Contact Tolomatic if higher temperature is required)					
IP RATING	Standard IP65, Optional IP67 (Static)						
REL. HUMIDITY (NON-CONDENSING)	5 to 90%						
SHOCK	20g peak, 6 msec duration						
VIBRATION	2.5g 30...2,000 Hz						

*In vertical applications an unpowered IMA will require a brake to maintain position if the load on the actuator exceeds this value

**Value given is for a zero stroke actuator

Motor Specifications:

SERIES		IMA22				IMA33				IMA44		IMA55	
WINDING/MOTOR VOLTAGE		MV21	MV41	MV23	MV43	MV21	MV41	MV23	MV43	MV23	MV43	MV23	MV43
TORQUE CONSTANT (K _T)	in-lb/A Peak	3.3	6.6	4.3	8.2	5.4	10.7	5.5	10.7	5.4	10.6	6.7	13.4
	N-m/A Peak	0.37	0.74	0.49	0.93	0.61	1.21	0.62	1.21	0.61	1.20	0.76	1.51
VOLTAGE CONSTANT (K _e)	V/Krpm Peak	51	102	61	122	81	160	79.8	154	78.1	153.1	100	201
CONTINUOUS STALL TORQUE	in-lb	7.5		13.3		16		39	38	74	75	112	112
	N-m	0.85		1.50		1.8		4.4	4.3	8.4	8.5	12.7	12.7
CONTINUOUS STALL CURRENT	Arms	1.6	0.8	2.2	1.15	2.1	1.1	5	2.5	9.7	5	11.8	5.9
PEAK TORQUE	in-lb	22.5		39.9		48		117	114	222	225	280	280
	N-m	2.54		4.5		5.4		13.2	12.9	25.1	25.4	25.3	25.3
PEAK CURRENT	Arms	4.8	2.4	6.6	3.45	6.3	3.3	15	7.5	29.1	15	29.5	14.8
RESISTANCE	Ohms	18.1	72.4	7.1	28.3	10	40.1	2.07	8.3	0.58	2.32	0.57	2.93
INDUCTANCE	mH	10.7	42	4.5	18	13.6	54.1	3.8	15	2.75	11.5	1.4	5.8
NO. OF POLES	8												
BUS VOLTAGE	Vrms	230	460	230	460	230	460	230	460	230	460	230	460
	RPM	4,264						3,500				2,400	

Sold & Serviced By: 

Toll Free Phone: (877) SERV098
Toll Free Fax: (877) SERV099



Performance data was validated using an aluminum face mount plate: IMA22/33 (8.25" x 7.0" x 0.7"); IMA44 (9.0" x 9.0" x 0.7"); IMA55 (9.0" x 9.0" x 1.0"); Ambient Temperature = 77°F (25°C); Elevation < 3281' (1,000 m); Drive specifications: Sinusoidal Commutation and PWM Voltage Source

IMA - Integrated Motor Actuator

ON-LINE SIZING
AVAILABLE AT WWW.
TOLOMATIC.COM
ACTUATOR
SIZING

SPEED vs THRUST

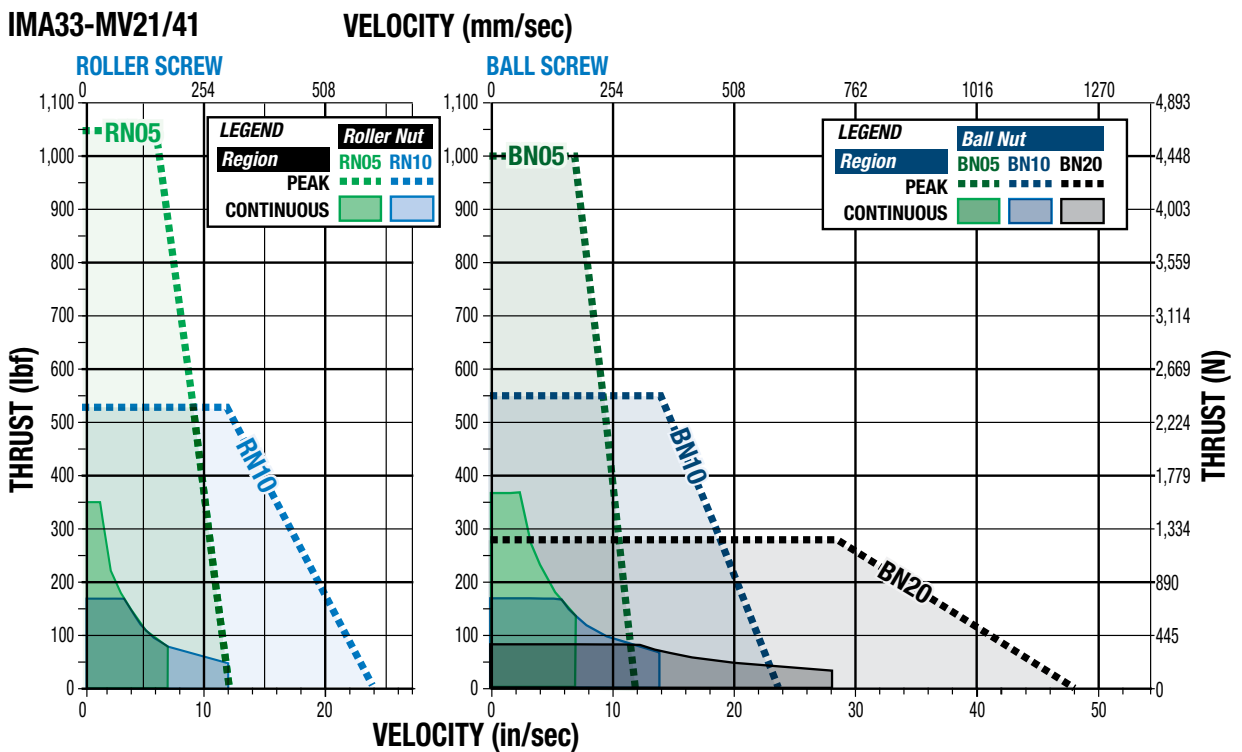
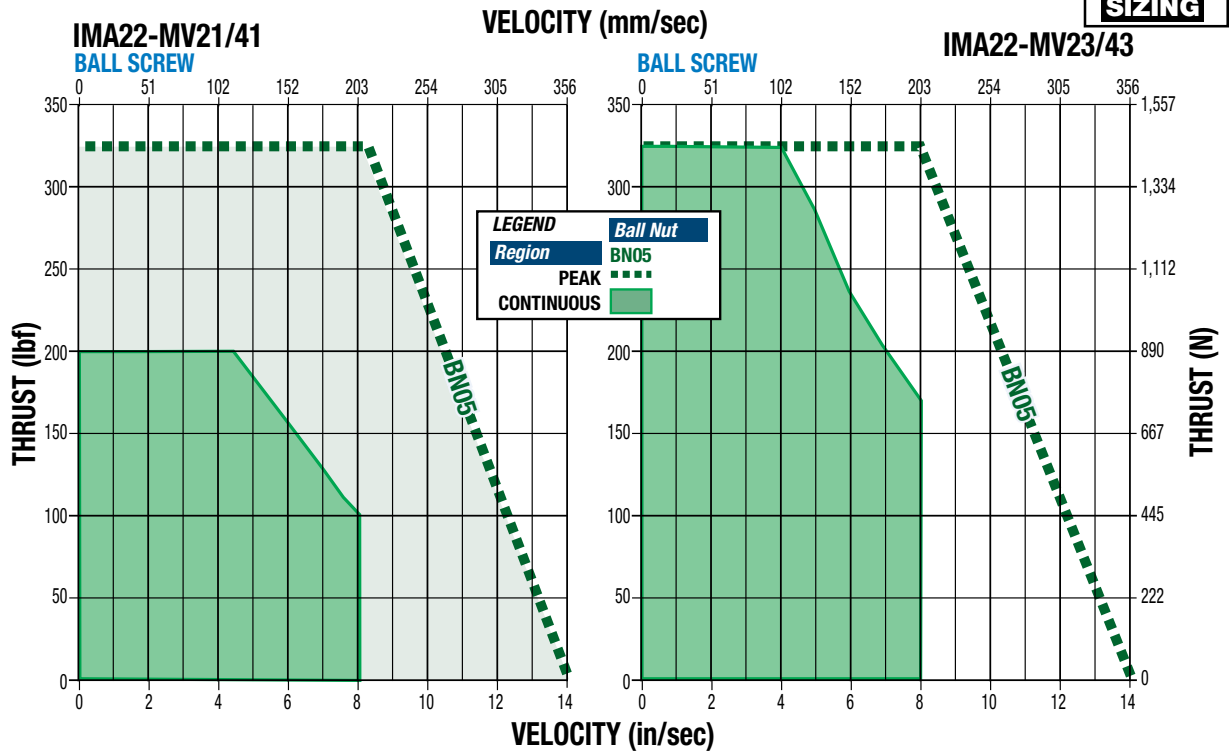

Sold & Serviced By:



Toll Free Phone (877) SERVING
Toll Free Fax (877) SERVING
www.electromate.com
sales@electromate.com

PEAK REGION is the maximum performance capabilities of the actuator system. Higher peak thrusts are achievable by servo motor actuator systems, so please consult Tolomatic before exceeding catalog rating.

CONTINUOUS REGION is defined as the RMS thrust and velocity limit that is derived from the thermal limits of the actuator system to achieve the dynamic load rating of the screw. (Example: Extend and retract under force 100% of the time with no dwells.)

IMA - Integrated Motor Actuator

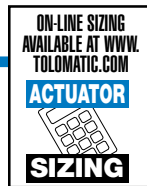

SPEED vs THRUST

IMA33-MV23/43

VELOCITY (mm/sec)

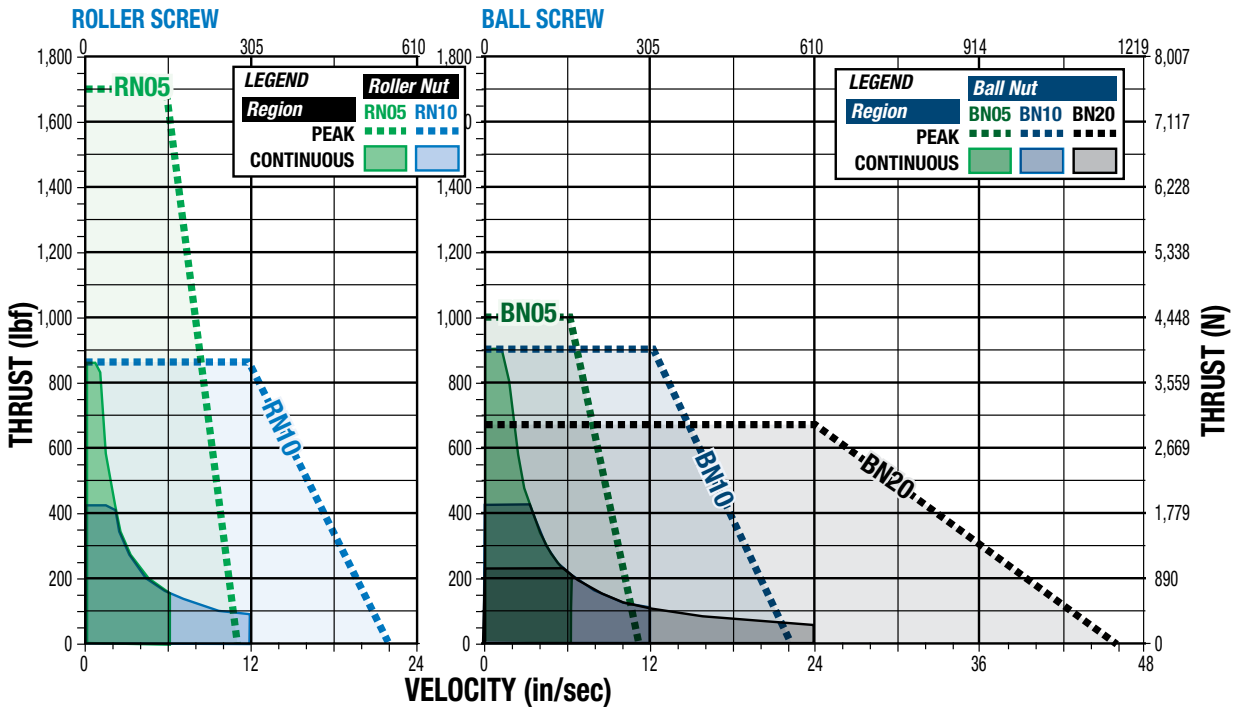

IMA44-MV23/43

VELOCITY (mm/sec)

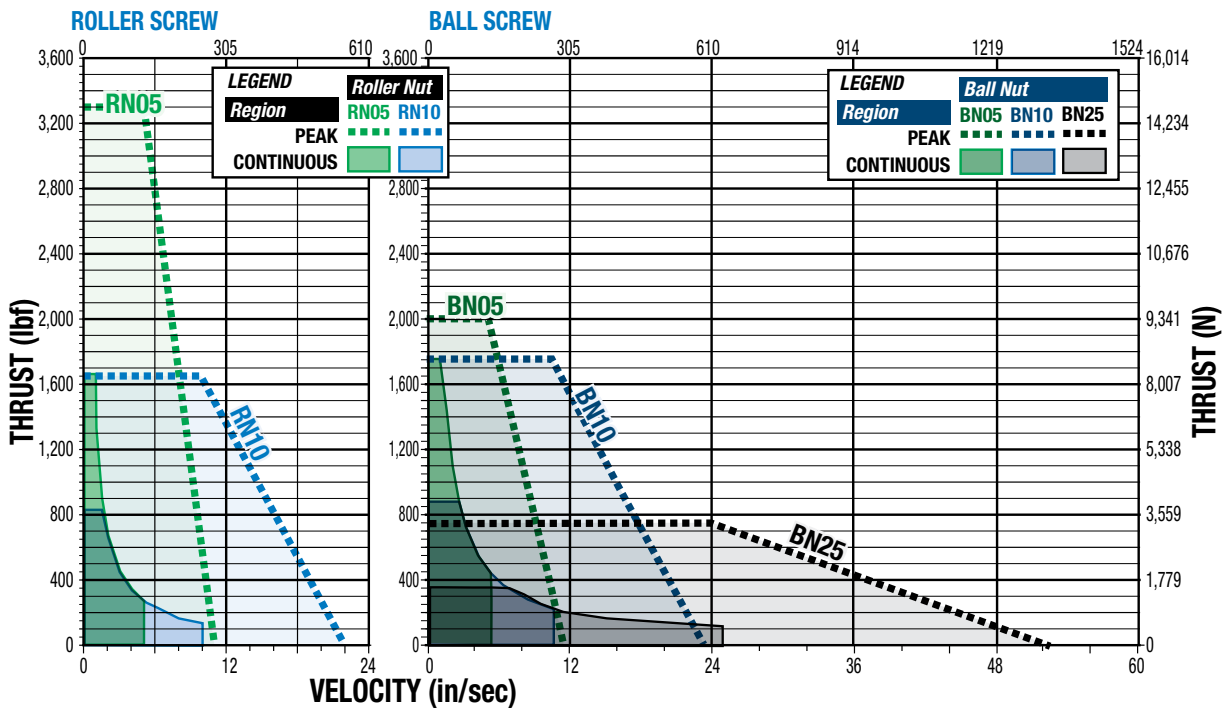

Sold & Serviced By:



PEAK REGION is the maximum performance capabilities of the actuator system. Higher peak thrusts are achievable by servo motor actuator systems, so please consult Tolomatic before exceeding catalog rating.

Toll Free Phone (877) SERV098

Toll Free Fax (877) 634-5133

www.electromate.com

sales@electromate.com

CONTINUOUS REGION is defined as the RMS thrust and velocity limit that is derived from the thermal limits of the actuator system to achieve the dynamic load rating of the screw. (Example: Extend and retract under force 100% of the time with no dwells.)

IMA - Integrated Motor Actuator



SPEED vs THRUST

IMA55-MV23/43

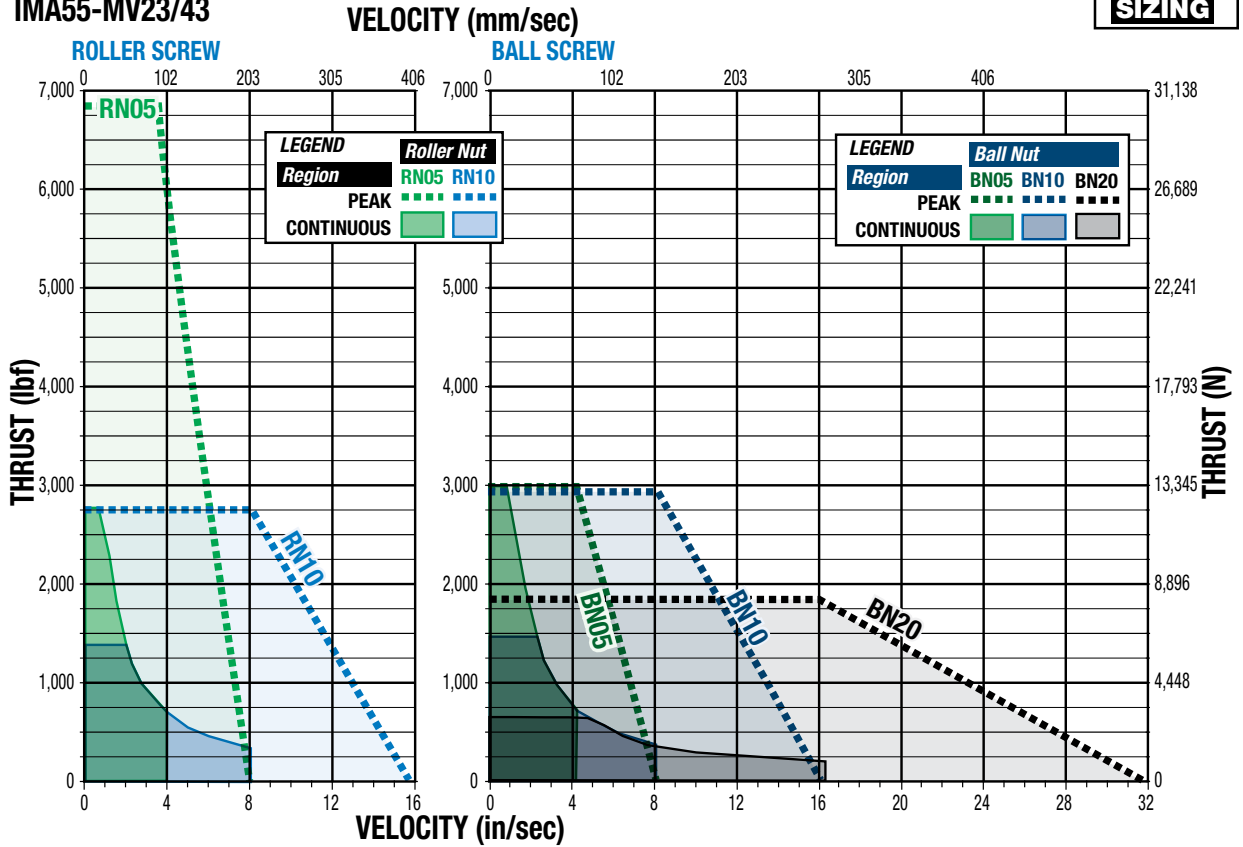

PEAK REGION is the maximum performance capabilities of the actuator system. Higher peak thrusts are achievable by servo motor actuator systems, so please consult Tolomatic before exceeding catalog rating.

CONTINUOUS REGION is defined as the RMS thrust and velocity limit that is derived from the thermal limits of the actuator system to achieve the dynamic load rating of the screw. (Example: Extend and retract under force 100% of the time with no dwells.)

CRITICAL SPEED

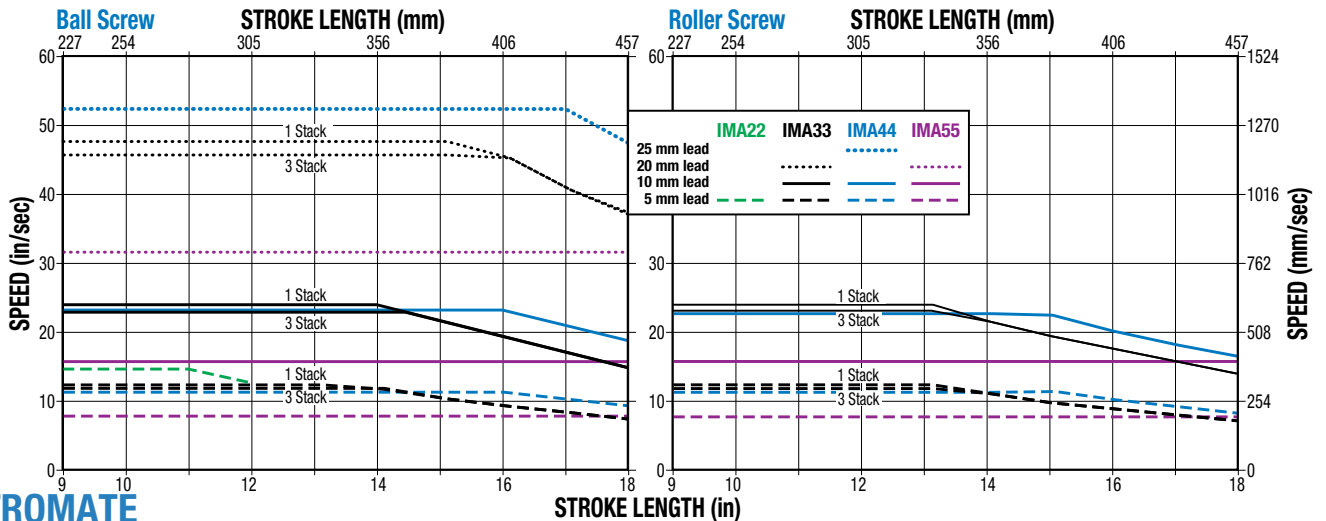

Sold & Serviced By:
ELECTROMATE

Toll Free Phone (877) SERV099 *All curves represent properly lubricated and maintained actuators.*

Toll Free Fax (877) SERV099

www.electromate.com

sales@electromate.com

IMA - Integrated Motor Actuator



ROLLER SCREW BUCKLING LOAD

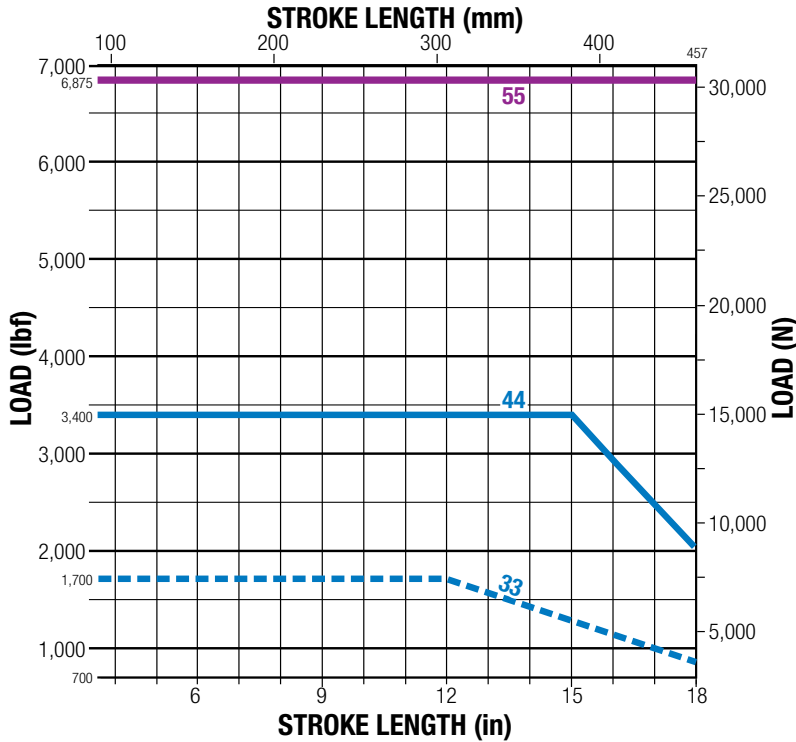

All curves represent properly lubricated and maintained actuators.

LIFE

BALL SCREW

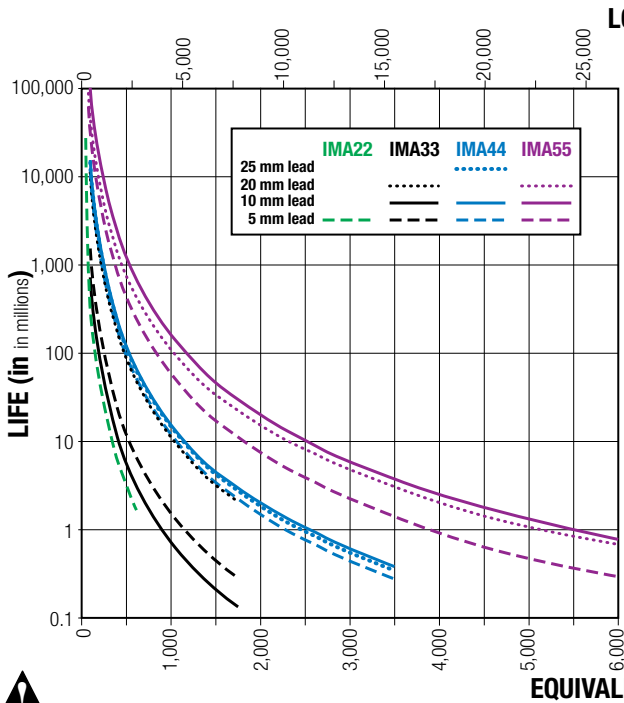

ROLLER SCREW

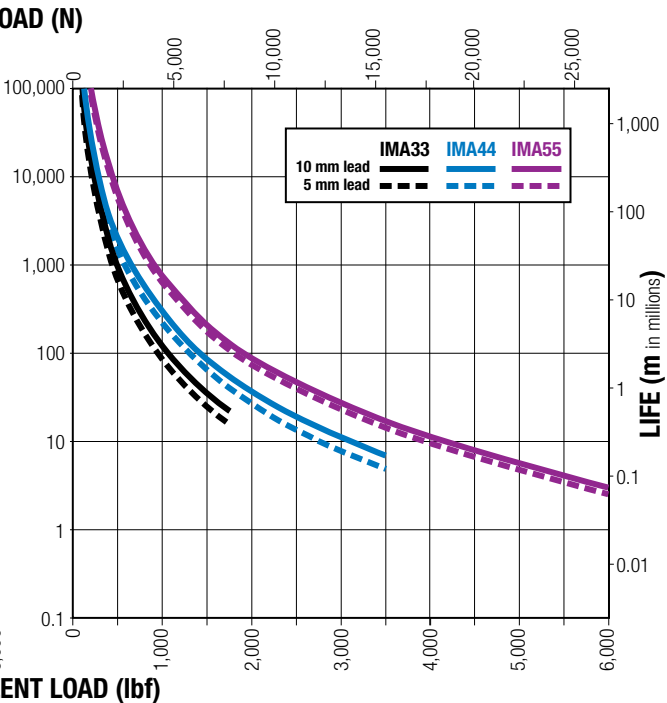

NOTE: The L_{10} expected life of a ball screw linear actuator is expressed as the linear travel distance that 90% of properly maintained ball screw actuators are expected to meet or exceed. This is not a guarantee and this graph should be used for estimation purposes only.

The underlying formula that defines this value is:

$$L_{10} = \left(\frac{C}{P_e} \right)^3 \cdot l =$$

Travel life in millions of units (in or mm), where:

- C = Dynamic load rating (lbf) or (N)
- P_e = Equivalent load (lbf) or (N)
- l = Screw lead (in/rev) or (mm/rev)

Use the "Equivalent Load" calculation below, when the load is not constant throughout the entire stroke. In cases where there is only minor variation in loading, use greatest load for life calculations.

$$P_e = \sqrt[3]{\frac{\% (P_1)^3 + \% (P_2)^3 + \% (P_3)^3 + \% (P_n)^3}{100}}$$

Where:

- P_e = Equivalent load (lbs) or (N)
- P_n = Each increment at different load (lbs) or (N)
- $\%n$ = Percentage of stroke at load increment

IMA - Integrated Motor Actuator

CALCULATING RMS THRUST AND VELOCITY FOR SEVERE DUTY

Servo motor actuator systems have two speed / thrust curves: one for severe duty (continuous) and another for operating region (intermittent or peak). The root mean square (RMS) thrust & velocity is based on the application duty cycle and must fall within the severe duty region of the actuator system. The application maximum thrust & velocity must fall within the operating region of the actuator system. Higher peak thrusts are achievable by the actuator system, so please consult Tolomatic before exceeding catalog ratings. Use the following formulas when calculating the RMS thrust & velocity. When selecting a servo motor actuator system, it is recommended to add a margin of safety of 15% to the thrust and velocity required to move the load.

$$T_{RMS} = \sqrt{\frac{\sum (T_i^2 \times t_i)}{\sum (t_i)}}$$

$$V_{RMS} = \sqrt{\frac{\sum (V_i^2 \times t_i)}{\sum (t_i)}}$$

Where:
 T_{RMS} = RMS Thrust
 V_{RMS} = RMS Velocity
 T_i = Thrust during interval i
 V_i = Velocity during interval i
 t_i = Time interval i

SIDE LOAD CONSIDERATIONS

The IMA integrated motor actuator is not meant to be used in applications where side loading occurs.

Loads must be guided and supported. Loads should be aligned with the line of motion of the thrust rod.

Side loading will affect the life of the actuator.

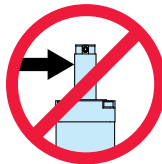

IMA SIDE LOAD SPECIFICATIONS

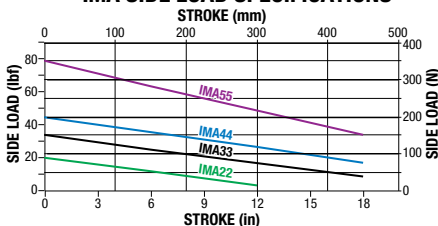

BRAKE CONSIDERATIONS

An un-powered IMA will require a brake to maintain its position if the force on the actuator exceeds Back Drive Force listed in the table on page IMA_8.

A brake can be used with the actuator to keep it from backdriving, typically in vertical applications. A brake may be used for safety reasons or for energy savings allowing the actuator to hold position when un-powered. See page IMA_23 for ordering information.

NOTE: The optional Spring-Applied, Electronically-Released Brake requires 24V power. Input current rating:

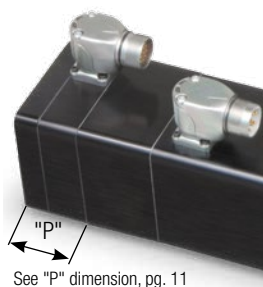

See "P" dimension, pg. 11

Sold & Serviced by:
ELECTROMATE
 Toll Free Phone: 1-877-527-0099
 Toll Free Fax: 1-877-527-0098
 www.electromate.com
 sales@electromate.com

IMA22: 0.35 Amps;
 IMA33: 0.43 Amps;
 IMA44: 0.67 Amps;
 IMA55: 0.66 Amps.

CALCULATING LUBRICATION INTERVAL

IMA actuators require periodic re-lubrication to maintain optimal performance. Below are formulas to help determine lubrication interval. See IMA User Guide (#2700-4001) for formula definitions, complete instructions and examples.

BALL SCREW

STEP 1: $P_{IMA} = V_{RMS} \times T_{RMS} \times 0.113$ (watts)

STEP 2. Select the appropriate actuator power level

P_c	33	44	55
P_c	105	185	240

STEP 3: $K_p = \frac{P_c}{P_{IMA}}$

STEP 4: $t_l = 1000$ (hours) = $K_p < 1$
 $t_l = 9000$ (hours) = $K_p > 1$

- Re-lubricate with Mobilith SHC220 Grease #2744-1016 (Quantity: IMA33: 3.0 g; IMA44: 5.0 g; IMA55: 7.0 g) into the grease zerk located on the rod end.
- IMA22 ballscrew does not require re-lubrication

ROLLER SCREW

STEP 1: $t_{BL} = 4500 \times (V_{RMS})^{-1.57}$ (hours)

STEP 2: $K_T = K_{Co} \left(\frac{T_{PEAK}}{P_e} \right) - 0.15$

	33RN05	33RN10	44RN05	44RN10	55RN05	55RN10
K_{Co}	0.24	0.44	0.26	0.40	0.31	0.84

STEP 3: $t_L = t_{BL} \times K_T$ (hours)

- Re-lubricate with Tolomatic Grease #2744-9099 (Quantity: IMA33: 3.0 g; IMA44: 5.0 g; IMA55: 7.0 g) into the grease zerk located on the rod end.

Brake Specifications:

	SERIES	IMA22	IMA33	IMA44	IMA55
ROTOR INERTIA	oz-in ²	0.052	0.112	0.656	0.587
	gm-cm ²	19	73	239	214
CURRENT	Amp	0.35	0.43	0.67	0.66
HOLDING TORQUE	in-lb	14	35	89	145
	N-m	1.6	4.0	9.0	16.4
ENGAGE TIME	mSec	75	40	25	15
DISENGAGE TIME	mSec	20	50	35	25
VOLTAGE	Vdc	24			

IMA - Integrated Motor Actuator



Dimensions: **All Sizes**

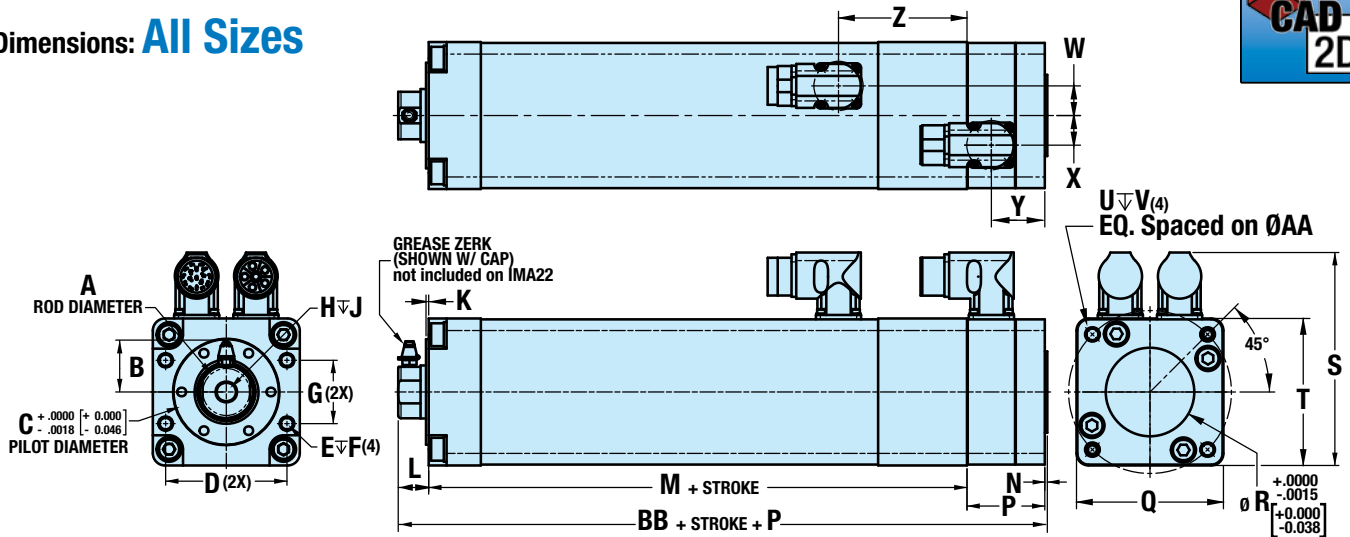

	IMA22	IMA33	IMA44	IMA55
A	0.999	1.186	1.499	2.249
mm	25.38	30.13	38.08	57.13
B	—	1.11	1.27	1.65
mm	—	28.3	32.3	41.9
C	1.8898	2.3622	2.8346	3.937
mm	48.000	60.000	72.000	100.000
D	2.126	2.717	3.346	4.331
mm	54.00	69.00	85.00	100.00
E	—	—	—	—
mm	M6 x 1.0	M8 x 1.25	M8 x 1.25	M12 x 1.75
F	0.52	0.57	0.68	0.89
mm	13.2	14.5	17.1	22.5
G	0.787	1.417	2.165	2.559
mm	20.00	36.00	55.00	65.00
H	—	—	—	—
mm	M8 x 1.25	M12 x 1.25	M20 x 1.5	M27 x 2.0
J	0.65	0.88	1.02	1.50
mm	16.5	22.2	25.9	38.1
K	0.06	0.06	0.06	0.06
mm	1.5	1.5	1.5	1.5
L	0.68	0.68	0.66	0.95
mm	17.3	17.3	16.8	24.1
M	4.32	6.05	7.88	10.48
mm	109.8	153.7	200.0	266.2
N	0.06	0.06	0.06	0.06
mm	1.5	1.5	1.5	1.5
P1	1.62	1.74	1.74	1.90
mm	41.2	44.2	44.2	48.2
P2	3.41	3.18	3.15	3.81
mm	86.7	80.8	80.0	96.8
P3	—	1.98	1.98	2.14
mm	—	50.3	50.3	54.3
P4	—	3.68	3.50	3.81
mm	—	93.5	89.0	96.8
P5	1.62	1.74	1.74	2.36
mm	41.2	44.2	44.2	59.9

	IMA22	IMA33	IMA44	IMA55
P6	3.41	3.18	3.15	3.81
mm	86.7	80.8	80.0	96.8
P7	2.31	2.33	2.33	2.66
mm	58.7	59.2	59.2	67.5
P8	3.79	3.96	3.90	4.39
mm	96.3	100.6	99.1	111.5
Q	2.50	3.29	4.35	5.66
mm	63.5	83.6	110.5	143.6
R	1.5748	1.9685	2.9528	3.937
mm	40.000	50.000	75.000	100.000
S1	4.11	4.91	5.96	7.26
mm	104.4	124.6	151.4	184.3
S2	4.02	4.81	5.87	7.16
mm	102.0	122.2	149.0	181.9
S3	4.11	4.91	5.96	7.26
mm	104.4	124.6	151.4	184.3
S4	4.11	4.91	5.96	7.26
mm	104.4	124.6	151.4	184.3
S5	—	4.47	5.53	6.82
mm	—	113.5	140.4	173.3
T	2.50	3.29	4.35	5.66
mm	63.5	83.6	110.5	143.6
U	—	—	—	—
mm	M6 x 1.0	M8 x 1.25	M8 x 1.25	M12 x 1.75
V	0.53	0.65	0.65	0.80
mm	13.5	16.5	16.5	20.5
W	0.38	0.66	0.88	0.88
mm	9.5	16.8	22.2	22.2
X	0.38	0.66	0.88	0.88
mm	9.5	16.8	22.2	22.2
Y	1.08	1.20	1.20	1.35
mm	27.3	30.4	30.4	34.4
Z	2.39	2.88	3.07	3.42
mm	60.6	73.1	77.9	86.9
AA	2.756	3.622	5.000	6.102
mm	70.00	92.00	127.00	155.00
BB	5.06	6.79	8.6	11.49
mm	128.6	172.5	218.3	291.8

KEY FEATURES: 1-STACK & 3-STACK MOTORS

IMA22

SERIES		MV21/41	MV23/43
STROKE	in	3.0 to 12.0	6.0 to 12.0
	mm	76.2 to 304.8	152.4 to 304.8
PEAK THRUST	lbf	up to 325	up to 325
	N	up to 1,446	up to 1,446

IMA33

SERIES		MV21/41	MV23/43
STROKE	in	3.0 to 18.0	6.0 to 18.0
	mm	76.2 to 457.2	152.4 to 457.2
PEAK THRUST	lbf	up to 1,050	up to 1,700
	N	up to 4,673	up to 7,562

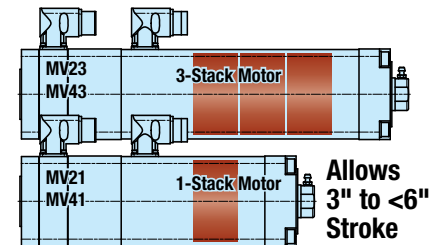

Sold & Serviced By:



Toll Free Phone (877) 468-6868
Toll Free Fax (877) 468-6868
www.electromate.com
sales@electromate.com

P6	= Resolver with Brake
P7	= Absolute Encoder
P8	= Absolute Encoder w/ Brake
S1	= Tolomatic Standard
S2	= Bosch MSK Motor Series

S3	= Emerson FM Series
S4	= Lenze MCS Motor Series
S5	= Emerson NT Series*
*Uses Box Mount Connectors (IP67 not available)	
*Not available as standard on IMA22	

IMA - Integrated Motor Actuator



Dimensions: Rod End Options

EXTERNAL THREADED ROD END (MET)

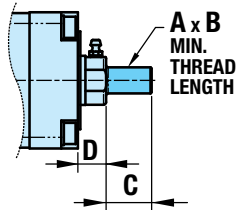
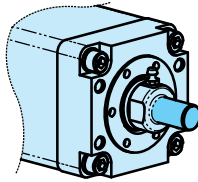

CLEVIS ROD END (RCL)

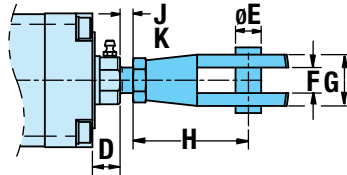
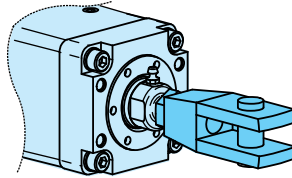

SPHERICAL ROD EYE (SRE)

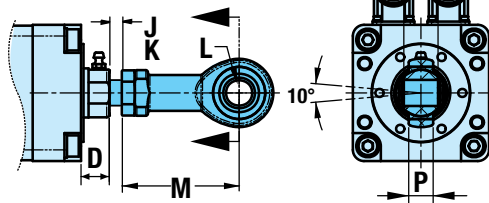
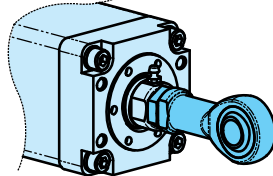

ALIGNMENT COUPLER (ALC + MET)

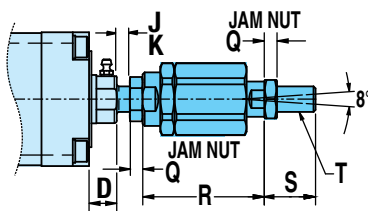
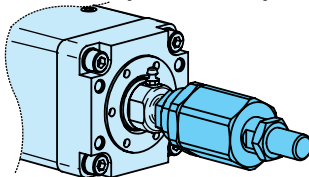

ALIGNMENT COUPLER FEMALE (ALC)

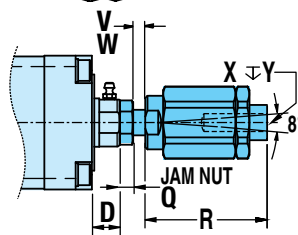
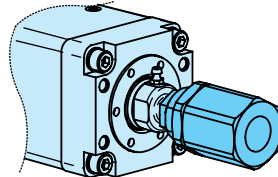

	IMA22	IMA33	IMA44	IMA55
A	—	—	—	—
mm	M10 x 1.25	M16 x 1.5	M20 x 1.5	M27 x 2.0
B	0.87	1.35	1.63	1.80
mm	22.1	34.3	41.4	38.1
C	0.97	1.47	1.75	2.00
mm	24.6	37.3	44.5	50.8
D	0.68	0.68	0.66	0.95
mm	17.3	17.3	16.8	24.1
E	0.394	0.630	0.787	1.181
mm	10.00	16.00	20.00	30.00
F	0.39	0.63	0.79	1.18
mm	10.0	16.0	20.0	30.0
G	0.79	1.26	1.57	2.17
mm	20.0	32.0	40.0	55.0
H	1.77	2.83	3.54	4.86
mm	45.0	72.0	90.0	123.5
J	0.36	0.52	0.56	0.40
mm	9.1	13.2	14.2	10.1
K	0.10	0.12	0.12	0.20
mm	2.5	3.0	3.0	5.1
L	0.394	0.630	0.787	1.181
mm	10.00	16.00	20.00	30.00
M	1.89	2.84	3.43	4.86
mm	48.0	72.0	87.0	123.5
N	0.55	0.83	0.98	1.46
mm	14.0	21.0	25.0	37.0
P	0.49	0.59	0.71	0.94
mm	12.5	15.0	18.0	25.0
Q	0.20	0.32	0.39	0.53
mm	5.0	8.0	10.0	13.5
R	2.09	2.99	3.23	3.66
mm	53.0	76.0	82.0	93.0
S	0.79	1.26	1.57	2.16
mm	20.0	32.0	40.0	54.0
T	—	—	—	—
mm	M10 x 1.25	M16 x 1.5	M20 x 1.5	M27 x 2.0
U	1.18	1.61	1.65	2.17
mm	30.0	41.0	42.0	55.0
V	—	—	0.43	0.43
mm	—	—	11.0	11.0
W	—	—	0.16	0.09
mm	—	—	4.1	2.4
X	—	—	—	—
mm	—	—	M20 x 1.5	M27 x 1.75
Y	—	—	1.65	2.13
mm	—	—	42.0	54.0

Sold & Serviced By:



Toll Free Phone (877) SEP 1333
 Toll Free Fax (877) SEP 1333
www.electromate.com
sales@electromate.com

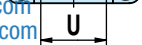

IMA - Integrated Motor Actuator



Dimensions: Mounting Options

FRONT FLANGE MOUNT (FFG)

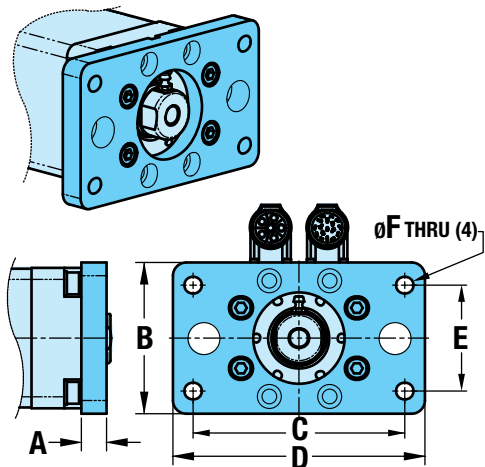

FRONT TRUNNION MOUNT (TRF)

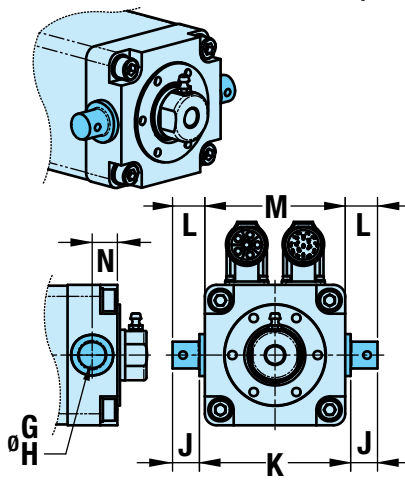

	IMA22	IMA33	IMA44	IMA55
A	0.44	0.59	0.63	0.70
mm	11.2	15.0	16.0	17.0
B	2.65	3.43	4.35	5.91
mm	67.3	87.0	110.5	150.0
C	3.937	4.961	5.906	9.055
mm	100.00	126.00	150.00	130.00
D	4.62	5.91	6.69	10.24
mm	117.3	150.0	170.0	260.0
E	1.969	2.480	2.953	4.528
mm	50.00	63.00	75.00	115.00
F	0.34	0.48	0.58	0.66
mm	8.7	12.3	14.7	16.7
G	0.472	0.629	0.787	0.984
mm	11.99	15.98	19.99	24.99
H	0.471	0.628	0.786	0.983
mm	11.96	15.95	19.96	24.97
J	0.34	0.63	0.79	0.98
mm	8.6	16.0	20.1	24.9
K	2.68	3.54	4.84	6.30
mm	68.0	90.0	123.0	160.0
L	0.43	0.76	1.04	1.30
mm	10.9	19.2	26.3	33.1
M	2.50	3.29	4.35	5.66
mm	63.5	83.6	110.5	143.6
N	0.59	0.59	0.83	1.10
mm	15.0	15.0	21.0	28.0

REAR CLEVIS MOUNT (PCD)

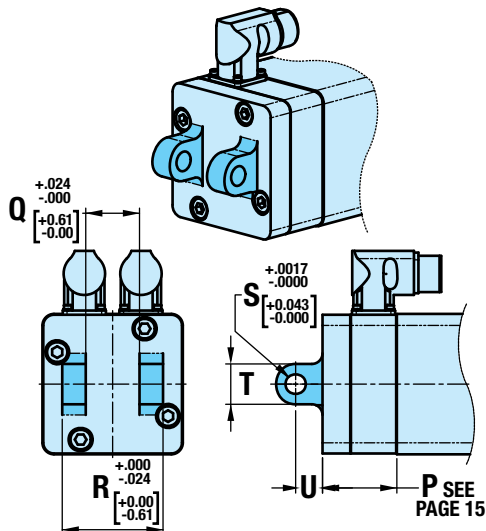

	IMA22	IMA33	IMA44	IMA55
Q	1.0236 ¹	1.2598	1.9685	2.3622
mm	26.000 ¹	32.000	50.000	60.000
R	1.7717 ²	2.3622	3.5433	4.3307 ⁴
mm	45.000 ²	60.000	90.000	110.000 ⁴
S	0.3937 ³	0.4724	0.6299	0.7874 ⁵
mm	10.000 ³	12.000	16.000	20.000 ⁵
T	0.787	0.945	1.417	1.575
mm	20.00	24.00	36.00	40.00
U	0.512	0.630	0.866	1.063
mm	13.00	16.00	22.00	27.00
V	0.472	0.629	0.787	0.984
mm	11.99	15.98	19.99	24.99
W	0.471	0.628	0.786	0.983
mm	11.96	15.95	19.96	24.97
X	0.34	0.63	0.79	0.98
mm	8.6	16.0	20.1	24.9
Y	2.68	3.54	4.84	6.30
mm	68.0	90.0	123.0	160.0
Z	0.43	0.76	1.04	1.30
mm	10.9	19.2	26.3	33.1
AA	2.50	3.29	4.35	5.66
mm	63.5	83.6	110.5	143.6
BB	0.59	0.79	0.98	1.26
mm	15.0	20.0	25.0	32.0

1	+0.0205"/-0.0000"
	+0.520mm/-0.000mm
2	+0.0000"/-0.0244"
	+0.000mm/-0.620mm
3	+0.0014"/-0.0000"
	+0.036mm/-0.000mm
4	+0.0000"/-0.0343"
	+0.000mm/-0.870mm
5	+0.0020"/-0.0000"
	+0.052mm/-0.000mm

REAR TRUNNION MOUNT (TRR)

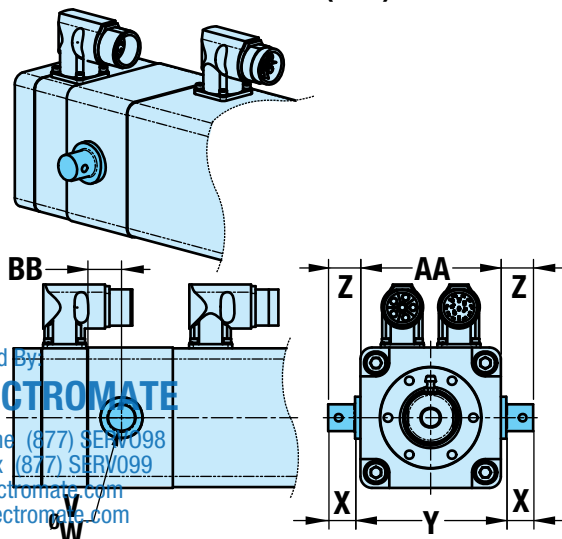

IMA - Integrated Motor Actuator



Dimensions: Options

SIDE MOUNTING (MST)

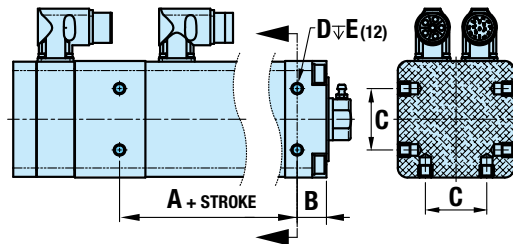
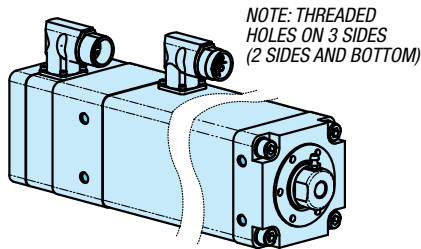

MOUNTING PLATES (MP2)

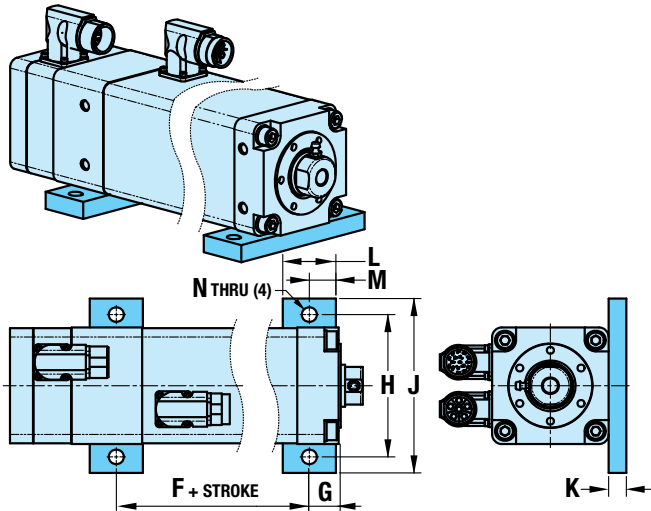

ANTI ROTATE (ARO)

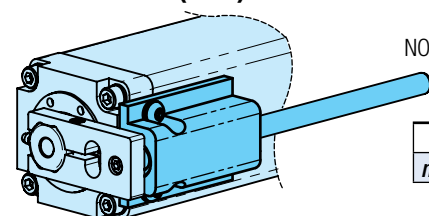

NOTE: When ARO is used together with FFG, stroke is reduced by dimension below

	IMA22	IMA33	IMA44	IMA55
in	0.30	0.45	0.51	0.44
mm	7.6	11.4	13.0	11.2

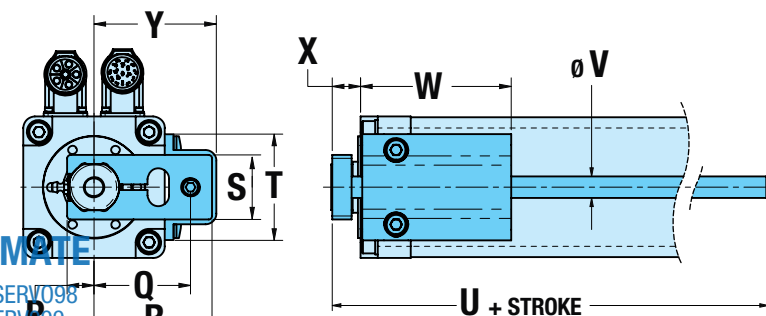

	IMA22	IMA33	IMA44	IMA55
A	2.67	3.97	5.63	7.53
mm	67.8	100.7	143.0	191.2
B	0.79	0.83	0.98	1.18
mm	20.0	21.0	25.0	30.0
C	1.339	1.732	1.969	3.346
mm	34.00	44.00	50.00	85.00
D	-	-	-	-
mm	M6 X 1.0	M8 x 1.25	M8 x 1.25	M12 x 1.75
E	0.52	0.57	0.68	0.89
mm	13.1	14.5	17.1	22.5
F	2.67	3.97	5.63	7.53
mm	67.8	100.7	143.0	191.2
G	0.79	0.83	0.98	1.18
mm	20.0	21.0	25.0	30.0
H	3.150	4.016	5.118	6.693
mm	80.00	102.00	130.00	170.00
J	3.94	4.92	6.10	7.87
mm	100.0	125.0	155.0	200.0
K	0.43	0.50	0.50	0.79
mm	11.0	12.7	12.7	20.0
L	1.18	1.50	1.50	1.97
mm	30.0	38.1	38.1	50.0
M	0.59	0.75	0.75	0.98
mm	15.0	19.1	19.1	25.0
N	0.34	0.42	0.42	0.59
mm	8.7	10.7	10.7	15.1

	IMA22	IMA33	IMA44	IMA55
P	0.50	0.63	0.78	1.25
mm	12.7	15.9	19.8	31.8
Q	1.71	2.24	2.78	3.74
mm	43.3	57.0	70.5	95.1
R	2.02	2.75	3.28	4.32
mm	51.2	69.7	83.2	109.7
S	1.37	1.50	1.81	2.69
mm	34.8	38.1	45.9	68.2
T	1.82	2.47	2.47	4.20
mm	46.2	62.7	62.7	106.7
U	3.19	4.14	4.27	5.60
mm	81.0	105.2	108.5	142.5
V	0.38	0.50	0.50	0.75
mm	9.5	12.7	12.7	19.1
W	2.56	3.50	3.66	4.55
mm	65.0	89.0	93.0	115.6
X	0.63	0.63	0.61	0.90
mm	16.1	16.1	15.5	22.8
Y	2.16	2.85	3.38	4.66
mm	54.9	72.3	85.7	118.3

Sold & Serviced By:



Toll Free Phone (877) SERV098
 Toll Free Fax (877) SERV099
 www.electromate.com
 sales@electromate.com

APPLICATION DATA WORKSHEET

Fill in known data. Not all information is required for all applications

ORIENTATION

Horizontal

Vertical

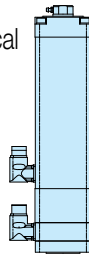
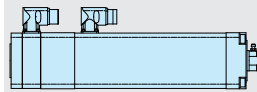

Incline °

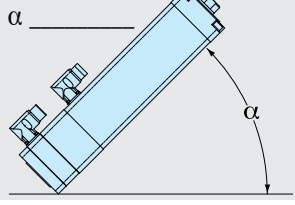

ACTUATOR FREE - On-line Sizing

SIZING

Or Call _____ for

Excellent Custom _____ nical Support

Load supported by actuator OR Load supported by other mechanism

MOVE PROFILE

EXTEND

Move Distance _____

inch millimeters

Move Time _____ sec

Max. Speed _____

in/sec mm/sec

Dwell Time After Move _____ sec

RETRACT

Move Distance _____

inch millimeters

Move Time _____ sec

Max. Speed _____

in/sec mm/sec

Dwell Time After Move _____ sec

NO. OF CYCLES

per minute per hour

HOLD POSITION?

Required

Not Required

After Move

During Power Loss

STROKE LENGTH

order in
mm ONLY

millimeters (S M)
(Metric)

NOTE: If load or force changes during cycle use the highest numbers for calculations

EXTEND

LOAD

lb. kg.
(U.S. Standard) (Metric)

FORCE

lb. kg.
(U.S. Standard) (Metric)

RETRACT

LOAD

lb. kg.
(U.S. Standard) (Metric)

FORCE

lb. kg.
(U.S. Standard) (Metric)

PRECISION

Repeatability _____

inch millimeters

OPERATING ENVIRONMENT

Temperature, Contamination, Water, etc.

MOTION PROFILE

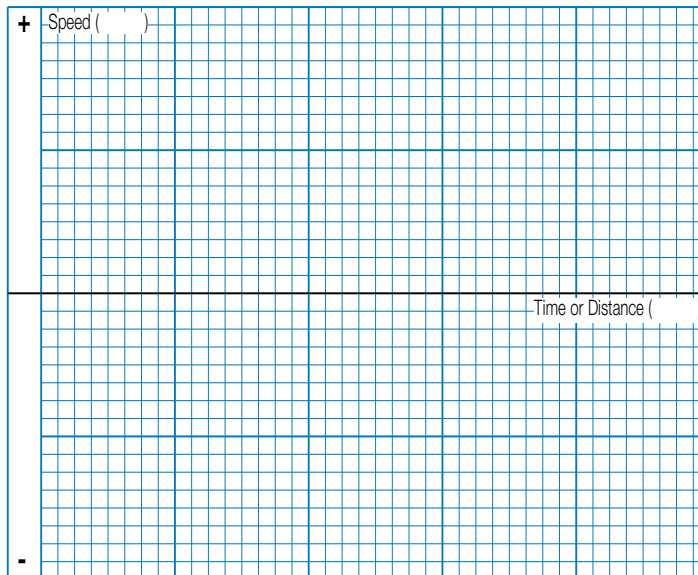

Graph your most demanding cycle, including accel/decel, velocity and dwell times. You may also want to indicate load variations and I/O changes during the cycle. Label axes with proper scale and units.

CONTACT INFORMATION

Name, Phone, Email
Co. Name, Etc.

Sold & Serviced By:



Toll Free Phone (877) SERV098

Toll Free Fax (877) SERV099

www.electromate.com

sales@electromate.com

FAX 1-763-478-8080

**SIZING AND SELECTION S
OR... CALL TOLOMATIC AT**

BLE ON-LINE AT

We will provide any

assistance needed to determine the proper actuator for the job.

EMAIL help@tolomatic.com

IMA - Integrated Motor Actuator

Selection Guidelines



1 ESTABLISH MOTION PROFILE

Using the application stroke length, desired cycle time and loads establish the motion profile details.

2 COMPARE OPERATING (PEAK) THRUST AND SPEED TO OPERATING REGION

Calculate the application required operating (peak) thrust and speed and compare to tables on pages IMA_8-9. The calculated thrust and speed must fall within the operating region of the actuator.

3 COMPARE SEVERE DUTY (CONTINUOUS) THRUST AND SPEED TO SEVERE DUTY REGION

Calculate the RMS thrust and speed required and compare to tables on pages IMA_8-9. The calculated thrust and speed must fall within the severe duty region. See complete instructions on page IMA_14 for help calculating continuous force.

$$T_{RMS} = \sqrt{\frac{\sum (T_i^2 \times t_i)}{\sum (t_i)}} \quad V_{RMS} = \sqrt{\frac{\sum (V_i^2 \times t_i)}{\sum (t_i)}}$$

4 CONSIDER SCREW/NUT CHOICES

Choose roller nuts for its longer life (see Life graph on page IMA_13) and higher peak loads (see graphs on pages IMA_10 & 11). Ball nuts are cost competitive and more efficient (see table on page IMA_8).

SCREW ACCURACY

Roller Nut	± 0.0004"/ft.	± 0.0102mm/300mm
Ball Nut	± 0.002"/ft.	± 0.051mm/300mm

5 VERIFY CRITICAL SPEED OF THE SCREW

Verify that the application's peak linear velocity does not exceed the critical speed value for the size and lead of the screw selected.

6 VERIFY AXIAL BUCKLING STRENGTH OF THE SCREW (ROLLER SCREW)

Verify that the peak thrust does not exceed the critical buckling force for the size of the screw selected (see graph on page IMA_13).

7 MOTOR WINDINGS & VOLTAGES

Choose motor windings optimized for 230 Vac and 460 Vac voltage busses. The 1 stack motor (MV21-230V & MV41-460V), available for the IMA22/33, allows strokes between 3 and 6" providing the thrust needed for many applications in a more compact, lighter weight package

8 CALCULATE LUBRICATION INTERVAL

See page IMA_14 for an overview and IMA Users Guide (#2700-4001) for complete instructions to calculate lubrication interval.

9 TEMPERATURE

The IMA is intended to operate in an environment with an ambient temperature between 50-104°F, (10-40°C). Performance should be de-rated if the ambient temperature is above 77°F (25°C). Contact the factory if the ambient tem-

perature does not fit within this range. NOTE: Temperature of the actuator's body can approach 180°F (82°C) in aggressive applications. Adequate clearance to ensure actuator's ambient conditions do not rise drastically should be allowed.

10 BRAKE CONSIDERATIONS

An un-powered IMA will require a brake to maintain its position if the force on the actuator exceeds Back Drive Force listed in the table on page IMA_8.

A brake can be used with the actuator to keep it from back-driving, typically in vertical applications. A brake may be used for safety reasons or for energy savings allowing the actuator to hold position when un-powered. See page IMA_23 for ordering information.

NOTE: The optional Spring-Applied / Electronically Released Brake requires 24V power. Input current rating: IMA22 - 0.35Amps; IMA33 - 0.43 Amps; IMA44 - 0.67 Amps; IMA55 - 0.66 Amps.

11 CHOOSE MOTOR CONNECTORS & FEEDBACK DEVICE

Connector choice and wiring emulates popular motor manufacturers for compatibility.

Current connector choices include:

- Bosch Rexroth MSK Series
- Emerson FM & NT Series
- Lenze MCA Series

Current feedback choices include:

- Digital Encoder
- Absolute Encoder
- Resolver

Contact Tolomatic for additional motor connectors, feedback combinations and motor files for third party drives.

12 CONSIDER MOUNTING & ROD END OPTIONS

Examine mounting options dimensional drawings on page IMA_15-18. Standard mounting on the IMA are 4 tapped holes on the front rod end face of the actuator. The Side Mount option (MST) includes 12 tapped holes, 4 on each side and 4 on the bottom of the actuator. Other fixed mounting options are the Front Flange Mount (FFG) and Mounting Plates (MP2). Pivoting mount options are Front Trunnion (TRF), Rear Trunnion (TRR) and Rear Clevis Mount (PCD).

Rod End Options include: External Threaded Rod End (MET), Clevis Rod End (RCL), Spherical Rod Eye (SRE) and Alignment Coupler (ALC).

NOTE: Regardless of the mounting option chosen, care must be taken to ensure that the load is guided and in-line with the thrust rod's line of motion. Misalignment of the thrust rod's line of motion will cause degradation in the actuator's expected life.

13 CONSIDER ENVIRONMENTAL RATING AND ANTI-ROTATE OPTIONS

The environmental rating for a standard IMA is IP65, choose IP67 for protection against water and dust ingress. Choose the Anti-Rotate Option (ARO) if required. Call Tolomatic at _____ for help in determining the best actuator for your application.

Sold & Serviced By:



Toll Free Phone (877) SERV098

Toll Free Fax (877) SERV099

www.electromate.com

sales@electromate.com

The IMA is matched to your drive/controller choice

The IMA has been successfully integrated with the following servo drive/controller and robot companies:

Controller/ Drive Manufacturers

- Allen Bradley
- Bosch Rexroth
- Copley
- Elmo
- Emerson
- Kollmorgen
- Lenze
- Omron
- Parker

Robot Manufacturers

- ABB
- Fanuc
- Kawasaki
- Kuka
- Motoman
- Nachi

Contact Tolomatic if your preferred servo drive/controller or robot supplier is not listed above.



Licensed Partner

For additional information regarding the integration of the IMA to an Allen Bradley/Rockwell drive see tech note linked below:
3600-4187_01_TN_IMA-AB-servo.pdf



The IMA is the most vigorously tested Tolomatic product yet

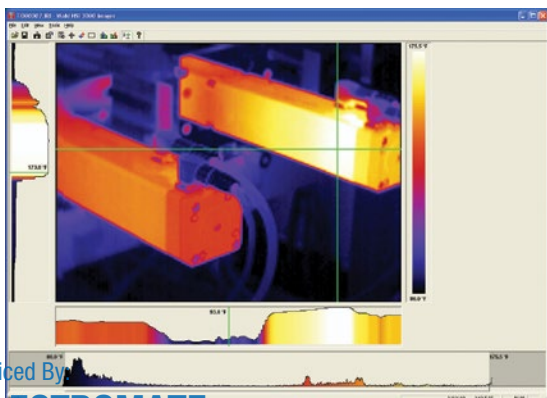

Cutting edge products like the IMA don't just fall into place. Over 20,000 hours of testing were required to prove the design that ships today. Thermal imaging, dynamic loading and other state-of-the-art techniques give us the confidence to stand behind our published performance data.

Sold & Serviced By
 **ELECTROMATE**

Toll Free Phone (877) SERV098
Toll Free Fax (877) SERV099
www.electromate.com
sales@electromate.com

IMA - Integrated Motor Actuator

Replacement Option Parts Ordering

PART NO.	DESCRIPTION
2722-9014	Spherical Rod Eye Kit, IMA22
2733-9014	Spherical Rod Eye Kit, IMA33
2744-9014	Spherical Rod Eye Kit, IMA44
2755-9014	Spherical Rod Eye Kit, IMA55
2722-9015	Clevis Rod End Kit, IMA22
2733-9015	Clevis Rod End Kit, IMA33
2744-9015	Clevis Rod End Kit, IMA44
2755-9015	Clevis Rod End Kit, IMA55
2124-1070	Alignment Coupler Kit, IMA22
2132-1060	Alignment Coupler Kit, IMA33
2150-1060	Alignment Coupler Kit, IMA44
2164-1060	Alignment Coupler Kit, IMA55
2722-9010	Mounting Plate Kit, IMA22
2733-9010	Mounting Plate Kit, IMA33
2744-9010	Mounting Plate Kit, IMA44
2755-9010	Mounting Plate Kit, IMA55
2722-9018	Front Flange Mount Kit, IMA22
2733-9018	Front Flange Mount Kit, IMA33
2744-9018	Front Flange Mount Kit, IMA44
2755-9018	Front Flange Mount Kit, IMA55
2722-2045	Rear Clevis Mount, IMA22
2733-1045	Rear Clevis Mount, IMA33
2744-1045	Rear Clevis Mount, IMA44
2755-1045	Rear Clevis Mount, IMA55
2722-9075	Anti Rotate, Bearing Assy, IMA22
2733-9075	Anti Rotate, Bearing Assy, IMA33 & 44
2755-9075	Anti Rotate, Bearing Assy, IMA55

PART NO.	DESCRIPTION
2722-9074	Anti Rotate, Shaft Clamp Assy, IMA22
2722-2211	Anti Rotate, Shaft, IMA22 - Indicate Stroke
2733-9074	Anti Rotate, Shaft Clamp Assy, IMA33
2733-1211	Anti Rotate, Shaft, IMA33 - Indicate Stroke
2744-9074	Anti Rotate, Shaft Clamp Assy, IMA44
2744-1211	Anti Rotate, Shaft, IMA44 - Indicate Stroke
2755-9074	Anti Rotate, Shaft Clamp Assy, IMA55
2755-1211	Anti Rotate, Shaft, IMA55 - Indicate Stroke
2733-1221	Motor Power Cable, NO Brake, 460 Vac, MV4
2733-1222	Motor Power Cable, w/ Brake, 460 Vac, MV4
2744-1221	Motor Power Cable, NO Brake, 230 Vac, MV2
2744-1222	Motor Power Cable, w/ Brake, 230 Vac, MV2
2733-1223	Feedback Cable, 12 pin (Resolver & Stegmann), flying leads
2733-1224	Feedback Cable, 17 pin (Digital Encoder), flying leads
2744-1016	Mobilith SHC220 Grease (Ball nut/screw)
2744-9099	Grease (Roller nut/screw)
2552-1132	Wiper, IMA22
2115-1030	Wiper, IMA33
2744-1003	Wiper, IMA44
2140-1030	Wiper, IMA55
2744-1213	Zerk Cap
2744-9092	Kit, Zerk with Cap
2744-1214	Grease Ftg. Plug

All parts are listed for REPLACEMENT ONLY. If not ordered on original unit the IMA may require additional tapped holes or replacement rod end. Contact Tolomatic.

Sold & Serviced By:



Toll Free Phone (877) SERV098
Toll Free Fax (877) SERV099
www.electromate.com
sales@electromate.com

IMA - Integrated Motor Actuator

Ordering

MODEL SELECTION (MUST BE IN THIS ORDER)

IMA 44 BN05 SM304.8 MV23 DT1D1N

OPTIONS (IN ANY ORDER)

ALC MP2 IP67 CR6

MODEL
IMA Integrated Motor Actuator

SIZE

22	22 Series Actuator
33	33 Series Actuator
44	44 Series Actuator
55	55 Series Actuator

NUT/SCREW
Screw/Nut combinations available

22	33	44	55	Description
BN05	BN05	BN05	BN05	Ball Nut, 5 mm lead
—	BN10	BN10	BN10	Ball Nut, 10 mm lead
—	BN20	—	BN20	Ball Nut, 20 mm lead
—	—	BN25	—	Ball Nut, 25 mm lead
—	RN05	RN05	*RN05	Roller Nut, 5 mm lead
—	RN10	RN10	*RN10	Roller Nut, 10 mm lead

*IMA55: Extended Catalog product, lead time may vary from standard 15 day delivery, contact Tolomatic

STROKE LENGTH
SM _____ Stroke, (76.2 to 457.2) enter stroke length in millimeters
NOTE: Maximum stroke for IMA22 is 12" (304.8mm)

MOTOR VOLTAGE

MV21*	230 Vac, Motor Voltage, 1 Stack Winding
MV41*	460 Vac, Motor Voltage, 1 Stack Winding
MV23	230 Vac, Motor Voltage, 3 Stack Winding
MV43	460 Vac, Motor Voltage, 3 Stack Winding

MOTOR CONNECTORS

DT1	Tolomatic Standard Motor
DA1	Allen Bradley MP Motor Series
DB1	Bosch Rexroth MSK Motor
DE1	Emerson FM Motor series
DE2**	Emerson NT Motor series
DL1	Lenze MCS Motor series

**NOTE: IP67 is not available with DE2 (Emerson NT connectors) Not available standard on IMA22

Some feedback devices are not compatible with some connectors
Contact Tolomatic for complete motor connector & feedback combination information

FEEDBACK DEVICE

A1	Stegmann Hiperface® Multi-turn ABS MT
D1	Digital Quadrature 2000 Line Encoder
R1	Resolver, BRX

BRAKE OPTION

N	NO Brake
B	Brake

Not all codes listed are compatible with all options.

Call Tolomatic available options to determine your application requirements.

ROD END OPTIONS

- **Standard**, female, internally threaded rod end
- MET** Male Externally Threaded Rod End
- SRE** Spherical Eye Rod End
- RCL** Clevis Rod End
- ALC** Alignment Coupler

NOTE: ALC (Alignment Coupler) requires ARO (Anti-Rotate) for proper operation

MOUNTING OPTIONS

- Standard Face Mount
- MP2** Mounting Plates - 2 req.
- FFG** Front Flange Mount
- TRF** Trunnion Mount, Front
- TRR** Trunnion Mount, Rear
- PCD** Clevis Mount, Rear
- MST** Side Mount (tapped holes on 3 sides)

OTHER OPTIONS

- IP67** Ingress Protection Rating
- ARO** Anti Rotate

CABLES

CR6 Tolomatic standard 6m flying lead cables, power and feedback

For custom cable lengths please contact Tolomatic. Lead times will vary.

NOTE: only use these cable options with DT1 motor connector, use cables from drive manufacturer for all others.

For IP rated cables contact Tolomatic

Sold & Serviced By:

ELECTROMATE

Toll Free Phone (877) SERV098

Toll Free Fax (877) SERV099

www.electromate.com

sales@electromate.com

NOTE: 22, 33, 44, 55 actuators only

The Tolomatic Difference Expect More From the Industry Leader:



Tolomatic designs and builds the best standard products, modified products & unique custom products for your challenging applications.



The fastest delivery of catalog products... Electric products are built-to-order in 15 days; Pneumatic & Power Transmission products in 5 days.



Online sizing that is easy to use, accurate and always up-to-date. Find a Tolomatic electric actuator to meet your requirements.



Match your motor with compatible mounting plates that ship with any Tolomatic electric actuator.



Easy to access CAD files available in the most popular formats to place directly into your assembly.



Our people make the difference! Expect prompt, courteous replies to all of your application and product questions.

Also Consider These Other Tolomatic Products:

Electric Products

Rod & Guided Rod Style Actuators, High Thrust Actuators, Screw & Belt Drive Rodless Actuators, Motors, Drives and Controllers

"Foldout" Brochure #9900-9074



Pneumatic Products

Rodless Cylinders: Band Cylinders, Cable Cylinders, Magnetically Coupled Cylinders/Slides; Guided Rod Cylinder Slides

"Foldout" Brochure #9900-9075

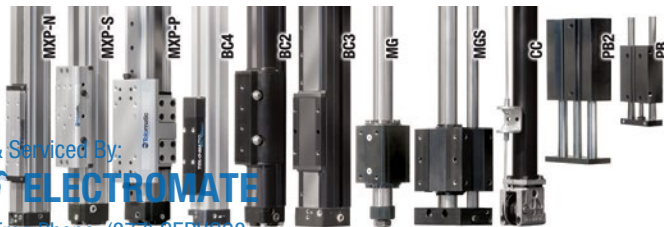

Power Transmission Products

Gearboxes: Float-A-Shaft®, Slide-Rite®; Disc Cone Clutch; Caliper Disc Brakes

"Foldout" Brochure #9900-9076

Sold & Serviced By:

 Toll Free Phone (877) SERV098
 Toll Free Fax (877) SERV099
www.electromate.com
sales@electromate.com