

# MXB RODLESS BELT DRIVE ACTUATORS

**ENDURANCE TECHNOLOGY<sup>SM</sup>**

**U** UNGUIDED

**P** PROFILED RAIL



**LINEAR SOLUTIONS MADE EASY**

Sold & Serviced By:

 **ELECTROMATE**

Toll Free Phone (877) SERV098

Toll Free Fax (877) SERV099

[www.electromate.com](http://www.electromate.com)

[sales@electromate.com](mailto:sales@electromate.com)

# MXB Rodless Belt Drive Actuators







DESIGNED TO OUTLAST EVERY BELT DRIVE ACTUATOR ON THE MARKET



The MXB belt drive electric actuator is exactly what you would expect from the industry's number one rodless supplier. Designed with our exclusive **ENDURANCE TECHNOLOGY™** features, the MXB delivers superior performance to meet the most demanding applications. Nobody knows rodless like Tolomatic, and the MXB proves it.

- MXB-**U** & MXB-**P**: Low profile to fit your application
- MXB-**P**: High precision bearings feature smooth, low breakaway motion
- MXB-**P**: Durable profiled rail design uses recirculating ball technology to reduce friction and extend actuator life.
- MXB-**P**: High load and bending moment capacities

## Choose from our broad line of MX products:

ELECTRIC				PNEUMATIC		
MXB		MXE		MXP		
Belt Drive		Screw Drive		Rodless Cylinder		
						
<b>P</b> Profiled Rail	<b>U</b> Unguided	<b>P</b> Profiled Rail	<b>S</b> Solid Bearing	<b>P</b> Profiled Rail	<b>S</b> Solid Bearing	<b>N</b> Internal Bearing
MXB16P	MXB16U	MXE16P	MXE16S	MXP16P	MXP16S	MXP16N
MXB25P	MXB25U	MXE25P	MXE25S	MXP25P	MXP25S	MXP25N
MXB32P	MXB32U	MXE32P	MXE32S	MXP32P	MXP32S	MXP32N
MXB40P	MXB40U	MXE40P	MXE40S	MXP40P	MXP40S	MXP40N
MXB50P	MXB50U	MXE50P	MXE50S	MXP50P	MXP50S	MXP50N
MXB63P	MXB63U	MXE63P	MXE63S	MXP63P	MXP63S	MXP63N

Sold & Serviced By:

 **ELECTROMATE**

Toll Free Phone (877) SERV098

Toll Free Fax (877) SERV099

[www.electromate.com](http://www.electromate.com)



[sales@electromate.com](mailto:sales@electromate.com)

# A Comparison of Tolomatic Belt Drive Actuators

## All Tolomatic belt drive actuators feature:

- High linear velocity
- High acceleration rate
- Long stroke lengths
- Excellent repeatability
- High duty cycles
- Low profile

## Unique features include:

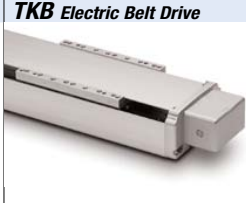
<i>MXB-U Electric Belt Drive</i>	<i>MXB-P Electric Belt Drive</i>	<i>B3W Electric Belt Drive</i>	<i>TKB Electric Belt Drive</i>
			
<ul style="list-style-type: none"> <li>• Requires external guidance and support</li> </ul>	<ul style="list-style-type: none"> <li>• High load and bending moment capacities</li> <li>• High precision bearings feature smooth, low breakaway motion</li> <li>• Durable profiled rail design uses recirculating ball technology to reduce friction and extend actuator life</li> </ul>		<ul style="list-style-type: none"> <li>• Superior rigidity, high moment loads</li> <li>• Straightness and flatness within 0.0002 inches per inch of stroke</li> <li>• Wide stable platform for XY applications</li> <li>• Lowest carrier deflection of any Tolomatic actuator</li> </ul>
<i>www.tolomatic.com</i> for complete information, search by literature number:			
#8500-4000	#8500-4000	#3600-4148	#3600-4609

## CONTENTS

MXB Belt Drive Actuator..	2
MX Products.....	2
Belt Drive Comparison.....	3
Belt Drive Advantages .....	4
Belt Construction .....	4
Applications .....	5
MXB-U Features.....	6
MXB-P Features .....	8
Specifications .....	10
Acceleration .....	11
Mounting Plate Requirements .....	11
Moment & Load Capacity.....	12
Load Deflection .....	13
MXB-U Actuator Dimensions.....	14
MXB-U Option Dimensions.....	14
MXB-P Actuator Dimensions.....	15
MXB-P Option Dimensions.....	16
Direct Drive Motor Mounting .....	17
Reduction Drive Motor Mounting.....	17
Switches .....	18
Application Data Worksheet .....	20
Selection Guidelines .....	21
Service Parts Ordering... ..	22
Ordering .....	23
Other Tolomatic Products.....	24



**World class performance,  
built-to-order and legendary  
customer service ...**

***what you expect from the  
rodless leader ...***



Sold & Serviced By:



Toll Free Phone (877) SERV098  
Toll Free Fax (877) SERV099  
www.electromate.com  
sales@electromate.com

# MXB Rodless Belt Drive Actuators

## ADVANTAGES OF BELT SOLUTIONS

The use of synchronous belts, often referred to as timing belts, have become a standard in the automated motion industry as an alternate to screw drive mechanisms for producing linear motion. MXB-**U** and MXB-**P** belt drive actuators are an excellent solution for applications that require:

- High linear velocities
- High acceleration rates
- Long stroke lengths
- Excellent repeatability
- High duty cycles

Tolomatic rodless belt drive actuators can achieve linear acceleration up to 1200 in/sec<sup>2</sup>, MXB-U velocity of up to 200 in/sec (5 m/sec) and MXB-P velocity of up to 150 in/sec (3.8 m/sec).

## BELT CONSTRUCTION

Tolomatic's standard belt is a polyurethane material reinforced with steel tension members to produce high carrier thrusts without belt stretch.

Tolomatic uses an HTD synchronous belt that features a curvilinear tooth profile. The HTD tooth profile distributes tooth load more evenly and provides greater tooth shear strength, allowing for higher thrust loading.

The deep teeth of the HTD profile are cogging-resistant, preventing potentially damaging positioning errors.

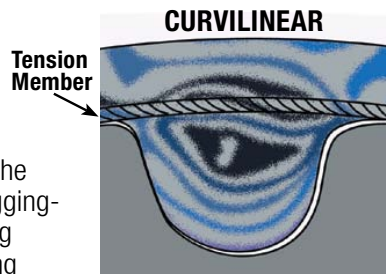

*Tolomatic's belt tooth profile distributes thrust force evenly*

## BELT DRIVE APPLICATIONS

Tolomatic MXB-**U** and MXB-**P** rodless belt drive actuators are:

- Easy to size and order
- Quick to install and maintain
- Simple to integrate and control

Both MXB-U and MXB-P are available in multiple frame sizes. The MXB-P belt drive actuator integrates the advantages of a linear belt solution with a load support and guidance system. This combination allows you to install a pre-assembled and compact solution, often without the need of external guide rails or load support systems. MXB-P offers options such as dual carriers for twice the load and moment capacity.

## **U** APPLICATION: Workcenter Positioning

- +Positioning
- +Assembly
- +Milling

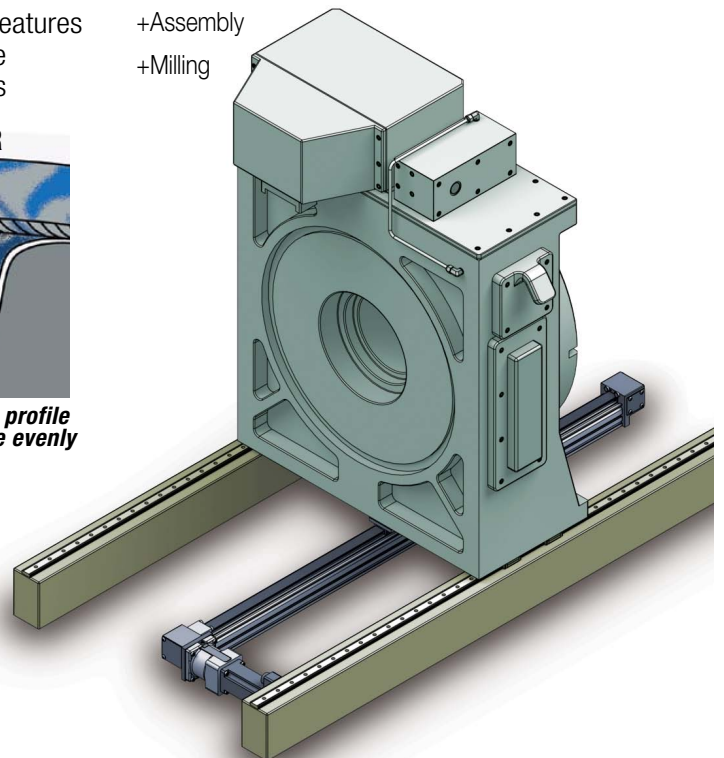

Sold & Serviced By:

 **ELECTROMATE**

Toll Free Phone (877) SERV098

Toll Free Fax (877) SERV099

[www.electromate.com](http://www.electromate.com)

[sales@electromate.com](mailto:sales@electromate.com)

# MXB Rodless Belt Drive Actuators

## **P** APPLICATION: High Speed Flying Cut Off

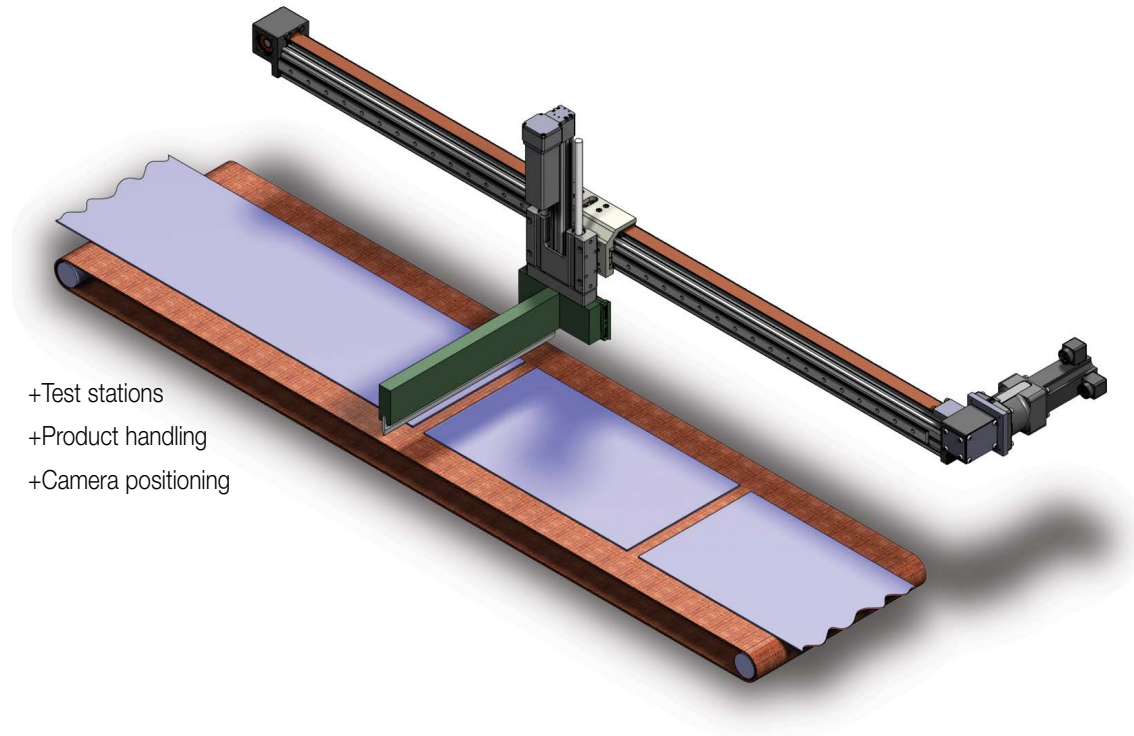

- +Test stations
- +Product handling
- +Camera positioning

## **P** APPLICATION: X-Y Multi-Axis

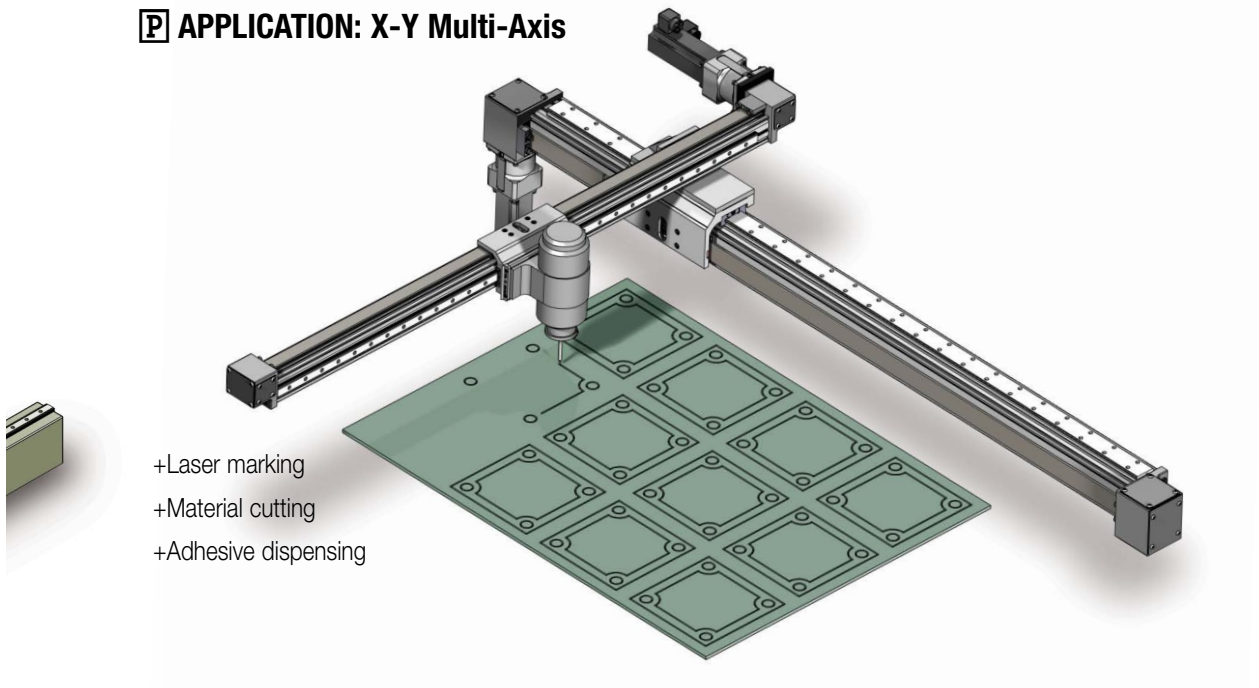

- +Laser marking
- +Material cutting
- +Adhesive dispensing

Sold & Serviced By:

**ELECTROMATE**

Toll Free Phone (877) SERV098

Toll Free Fax (877) SERV099

[www.electromate.com](http://www.electromate.com)

[sales@electromate.com](mailto:sales@electromate.com)

# MXB-U UNGUIDED BELT DRIVE ACTUATOR

**ENDURANCE TECHNOLOGY<sup>SM</sup>**

*Endurance Technology<sup>SM</sup> features are designed for maximum durability to provide extended service life.*

The MXB-U rodless style actuator is a pre-assembled compact linear belt solution for use in applications with existing guides & supports. This economical actuator features speeds up to 200 in/sec and thrusts up to 418 lbf. Built-to-order in stroke lengths up to 200 inches.

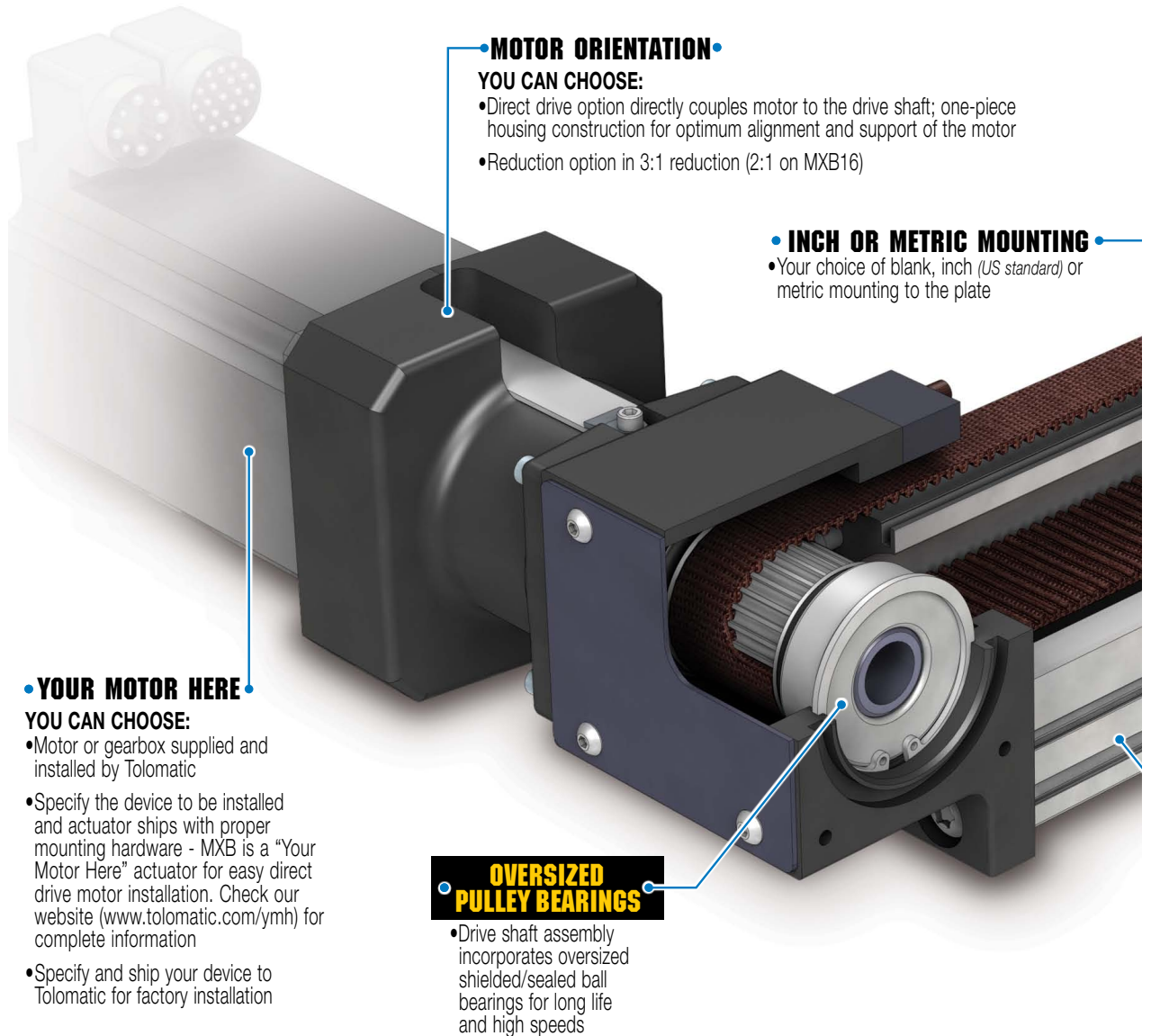

## • MOTOR ORIENTATION •

### YOU CAN CHOOSE:

- Direct drive option directly couples motor to the drive shaft; one-piece housing construction for optimum alignment and support of the motor
- Reduction option in 3:1 reduction (2:1 on MXB16)

## • INCH OR METRIC MOUNTING •

- Your choice of blank, inch (*US standard*) or metric mounting to the plate

## • YOUR MOTOR HERE •

### YOU CAN CHOOSE:

- Motor or gearbox supplied and installed by Tolomatic
- Specify the device to be installed and actuator ships with proper mounting hardware - MXB is a "Your Motor Here" actuator for easy direct drive motor installation. Check our website ([www.tolomatic.com/ymh](http://www.tolomatic.com/ymh)) for complete information
- Specify and ship your device to Tolomatic for factory installation

## • OVERSIZED PULLEY BEARINGS •

- Drive shaft assembly incorporates oversized shielded/sealed ball bearings for long life and high speeds

Sold & Serviced By:

**ELECTROMATE**

Toll Free Phone (877) SERV098

Toll Free Fax (877) SERV099

[www.electromate.com](http://www.electromate.com)

[sales@electromate.com](mailto:sales@electromate.com)

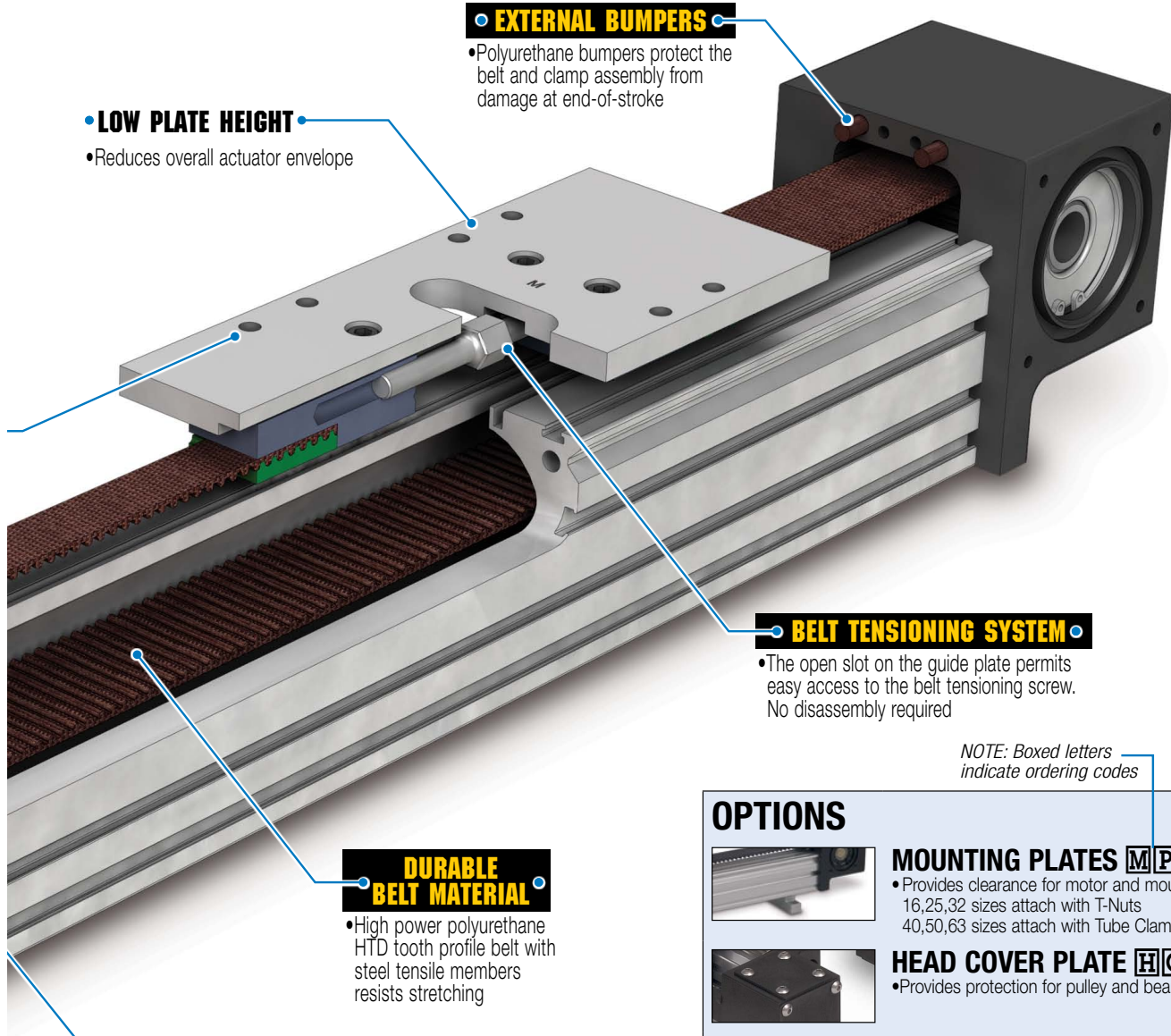

**• LOW PLATE HEIGHT**

• Reduces overall actuator envelope

**• EXTERNAL BUMPERS**

• Polyurethane bumpers protect the belt and clamp assembly from damage at end-of-stroke

**DURABLE BELT MATERIAL**

• High power polyurethane HTD tooth profile belt with steel tensile members resists stretching

**LIGHTWEIGHT ALUMINUM DESIGN**

• Clear anodized extrusion design is optimized for rigidity and strength

**BELT TENSIONING SYSTEM**

• The open slot on the guide plate permits easy access to the belt tensioning screw. No disassembly required

NOTE: Boxed letters indicate ordering codes

**OPTIONS**

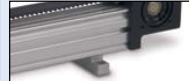

**MOUNTING PLATES MP**

• Provides clearance for motor and mount  
16,25,32 sizes attach with T-Nuts  
40,50,63 sizes attach with Tube Clamps



**HEAD COVER PLATE HCP**

• Provides protection for pulley and bearing



**TUBE CLAMPS TC**

• Used for intermediate support  
• Flush with bottom of actuator to retain low profile  
• Drop-in, adjustable mounting locations (Not available on the MXB16U)



**SWITCHES**

• Wide variety of sensing choices: Reed, Solid State PNP or NPN, available normally open or normally closed  
• Flush mount, drop-in installation  
• Bright LEDs, power & signal indication  
• CE rated, RoHS compliant

# MXB-P PROFILED RAIL BELT DRIVE ACTUATOR

**ENDURANCE TECHNOLOGY**<sup>SM</sup>

*Endurance Technology<sup>SM</sup> features are designed for maximum durability to provide extended service life.*

The MXB-P rodless electric belt-drive actuator is designed for applications requiring moderate to heavy load carrying and guidance. The MXB-P actuator features a profiled rail system with recirculating ball linear guides for optimal performance. The MXB-P belt-driven actuator features speeds up to 150 in/sec and thrusts up to 418 lbf. Built-to-order in stroke lengths up to 200 inches.

## • LOW CARRIER HEIGHT •

- Reduces overall actuator envelope
- Large mounting pattern for excellent load stability

## • DURABLE BELT MATERIAL •

- High power polyurethane HTD tooth profile belt with steel tensile members resists stretching

## • OVERSIZED PULLEY BEARINGS •

- Drive shaft assembly incorporates oversized shielded/sealed ball bearings for long life and high speeds

## • MOTOR ORIENTATION •

### YOU CAN CHOOSE:

- Direct drive option directly couples motor to the drive shaft; one-piece housing construction for optimum alignment and support of the motor
- Reduction option in 3:1 reduction (2:1 on MXB16)

## • YOUR MOTOR HERE •

### YOU CAN CHOOSE:

- Motor or gearbox supplied and installed by Tolomatic
- Specify the device to be installed and actuator ships with proper mounting hardware - MXB is a "Your Motor Here" actuator for easy direct drive motor installation. Check our website ([www.tolomatic.com/ymh](http://www.tolomatic.com/ymh)) for complete information
- Specify and ship your device to Tolomatic for factory installation

## • INCH OR METRIC MOUNTING •

- Your choice of inch (*US standard*) or metric mounting to the carrier

Sold & Serviced By:

**ELECTROMATE**

Toll Free Phone (877) SERV098

Toll Free Fax (877) SERV099

[www.electromate.com](http://www.electromate.com)

[sales@electromate.com](mailto:sales@electromate.com)



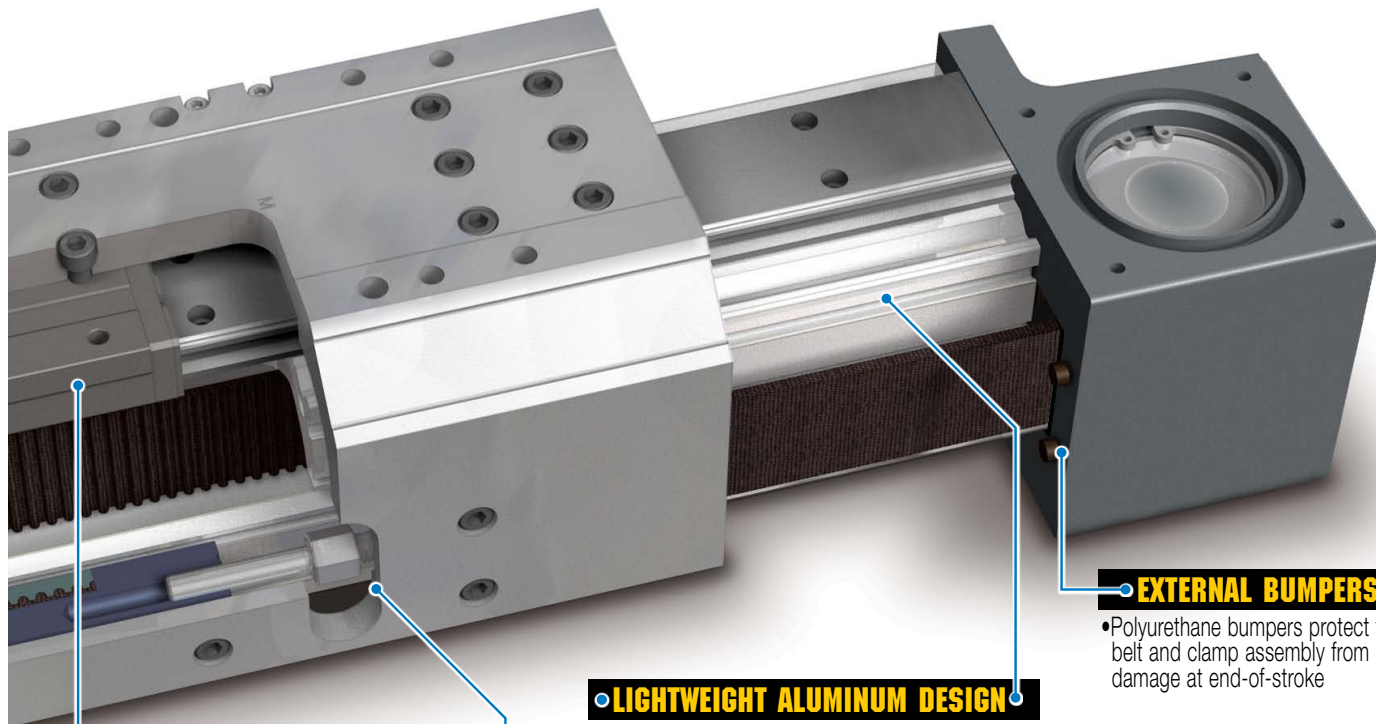

**BELT TENSIONING SYSTEM**

- The open slot on the carrier side permits easy access to the belt tensioning screw. No disassembly required and no need to remove the load from the carrier

**LIGHTWEIGHT ALUMINUM DESIGN**

- Clear anodized extrusion design is optimized for rigidity and strength

**EXTERNAL BUMPERS**

- Polyurethane bumpers protect the belt and clamp assembly from damage at end-of-stroke

**RECIRCULATING BALL BEARINGS**

- Recirculating ball bearings are used to reduce friction and extend actuator life
- Designed with a grease pocket between ball elements to reduce friction, noise and maintenance
- Large permissible moment loads
- High speed operation, low heat generation
- High precision, smooth, low friction motion

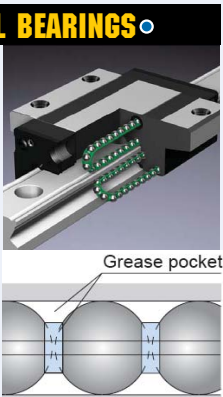

NOTE: Boxed letters indicate ordering codes

**OPTIONS**



**AUXILIARY CARRIER DC**

- 2X higher Fz & Fy (load) capacity
- High bending moment capacity



**MOUNTING PLATES MP**

- Provides clearance for motor and mount
- 16,25,32 sizes attach with T-Nuts
- 40,50,63 sizes attach with Tube Clamps



**TUBE CLAMPS TC**

- Used for intermediate support
  - Flush with bottom of actuator to retain low profile
  - Drop-in adjustable mounting locations
- (Not available on the 16, 25 or 32 MXB-P sizes)



**HEAD COVER PLATE HCP**

- Provides protection for pulley and bearing



**SWITCHES**

- Wide variety of sensing choices: Reed, Solid State PNP or NPN, available normally open or normally closed
- Flush mount, drop-in installation
- Bright LEDs, power & signal indication
- CE rated, RoHS compliant

Sold & Serviced By:



Toll Free Phone (877) SERV098  
Toll Free Fax (877) SERV099  
www.electromate.com  
sales@electromate.com

# MXB Rodless Belt Drive Actuators

SIZING SOFTWARE  
AVAILABLE AT WWW.  
TOLOMATIC.COM

## ACTUATOR SPECIFICATIONS AND BREAKAWAY TORQUE

U & P MXB SIZE	BELT WIDTH		BELT DEAD LENGTH		PULLEY PITCH DIAMETER		STROKE PER REVOLUTION		*MAXIMUM STROKE		BREAKAWAY TORQUE			
											SINGLE CARRIER		AUXILIARY CARRIER OPT. (MXB-P ONLY)	
	in	mm	in	mm	in	mm	in	mm	in	mm	lb-in	N-m	lb-in	N-m
16	0.39	10	14.29	363.0	0.753	19.1	2.366	60.1	230	5842	4.0	0.452	6.0	0.678
25	0.71	18	18.72	475.5	1.003	25.5	3.151	80.0	204	5181	5.0	0.565	7.0	0.791
32	0.98	25	21.89	556.0	1.253	31.8	3.936	100.0	203	5156	8.0	0.904	10.0	1.130
40	1.18	30	24.95	633.7	1.504	38.2	4.725	120.0	202	5130	10.0	1.130	12.0	1.356
50	1.57	40	27.25	692.2	1.754	44.6	5.510	140.0	202	5130	15.0	1.695	18.0	2.034
63	1.97	50	36.11	917.2	2.130	54.1	6.692	170.0	102	2590	20.0	2.260	25.0	2.825

\*Longer lengths may be possible with use of tube couplers - Contact Tolomatic

U MXB-U SIZE	WEIGHT								INERTIA					
	PLATE ASSEMBLY		BELT TENSIONER ASSEMBLY		BASE ACTUATOR		PER UNIT OF STROKE		DRIVE/IDLE PULLEY ASSEMBLIES		PLATE ASSEMBLY (INCLUDING BELT TENSIONER ASSEMBLY)		PER UNIT OF STROKE	
	lb	kg	lb	kg	lb	kg	lb/in	kg/cm	lb-in <sup>2</sup>	kg-cm <sup>2</sup>	lb-in <sup>2</sup>	kg-cm <sup>2</sup>	lb-in <sup>2</sup>	kg-cm <sup>2</sup>
16	0.11	0.05	0.10	0.05	1.59	0.72	0.084	0.0150	0.0085	0.0250	0.0335	0.0980	0.0005	0.0006
25	0.27	0.12	0.15	0.07	2.59	1.17	0.138	0.0246	0.0259	0.0759	0.1201	0.3515	0.0017	0.0020
32	0.48	0.22	0.30	0.13	4.17	1.89	0.237	0.0423	0.1416	0.4143	0.3451	1.0099	0.0037	0.0043
40	0.90	0.41	0.46	0.21	7.83	3.55	0.352	0.0629	0.3719	1.0884	0.8487	2.4836	0.0065	0.0075
50	1.03	0.47	0.72	0.33	9.93	4.50	0.472	0.0843	0.7243	2.1196	1.5103	4.4198	0.0117	0.0135
63	2.54	1.15	0.83	0.38	16.44	7.46	0.833	0.1488	1.9512	5.7101	4.2168	12.3401	0.0216	0.0249

P MXB-P SIZE	WEIGHT								INERTIA							
	CARRIER ASSEMBLY		BELT TENSIONER ASSEMBLY		BASE ACTUATOR		PER UNIT OF STROKE		DRIVE/IDLE PULLEY ASSEMBLIES		CARRIER ASSEMBLY (INCLUDING BELT TENSIONER ASSEMBLY)					
	lb	kg	lb	kg	lb	kg	lb/in	kg/cm	lb-in <sup>2</sup>	kg-cm <sup>2</sup>	SINGLE CARRIER		AUXILIARY CARRIER OPT.		PER UNIT OF STROKE	
16	0.39	0.18	0.10	0.05	2.38	1.08	0.102	0.0183	0.0085	0.0250	0.4856	1.4211	0.8716	2.5506	0.0005	0.0006
25	0.84	0.38	0.15	0.07	4.36	1.98	0.195	0.0348	0.0259	0.0759	0.9914	2.9013	1.8353	5.3708	0.0017	0.0020
32	1.64	0.74	0.30	0.13	7.83	3.55	0.318	0.0569	0.1416	0.4143	1.9356	5.6642	3.5757	10.4641	0.0037	0.0043
40	2.51	1.14	0.46	0.21	14.07	6.38	0.537	0.0959	0.3719	1.0884	2.9693	8.6893	5.4832	16.0460	0.0065	0.0075
50	5.03	2.28	0.72	0.33	20.84	9.45	0.749	0.1337	0.7243	2.1196	5.7498	16.8263	10.7770	31.5378	0.0117	0.0135
63	9.36	4.25	0.83	0.38	37.24	16.89	1.110	0.1981	1.9512	5.7101	10.1930	29.8288	19.5537	57.2221	0.0216	0.0249

**MAXIMUM VELOCITY** 200 in/sec 5080 mm/sec

**MAXIMUM VELOCITY** 150 in/sec 3810 mm/sec

**MAXIMUM ACCELERATION** 1200 in/sec<sup>2</sup> 30.48 m/sec<sup>2</sup>

**REPEATABILITY** ± 0.002 in ± 0.051 mm

**TEMPERATURE RANGE** 10 to 130 °F -12 to 54 °C

Heat generated by the motor and drive should be taken into consideration as well as linear velocity and work cycle time. For applications that require operation outside of the recommended temperature range, contact the factory.

**STRAIGHTNESS, FLATNESS** 0.00067 L in 0.01702 L mm

Actuator mounted on a flat surface and fully restrained (see Mounting Plate Requirements, page mxB\_11) L = Maximum distance between supports

The listed values relating to straightness/flatness are intended for reference purposes only, and not as an engineering standard of absolute tolerance for a given actuator. Appropriate installation is the single most important factor in reducing variation, so good engineering practices such as measurement, mapping, etc. must be employed in applications with stringent straightness/flatness requirements.

Sold & Serviced By:

ELECTROMATE

Toll Free Phone (877) SERV098

Toll Free Fax (877) SERV099

www.electromate.com

sales@electromate.com

# MXB Rodless Belt Drive Actuators

SIZING SOFTWARE  
AVAILABLE AT WWW.  
TOLOMATIC.COM

## MAXIMUM ACCELERATION AS A FUNCTION OF LOAD WEIGHT (U & P)

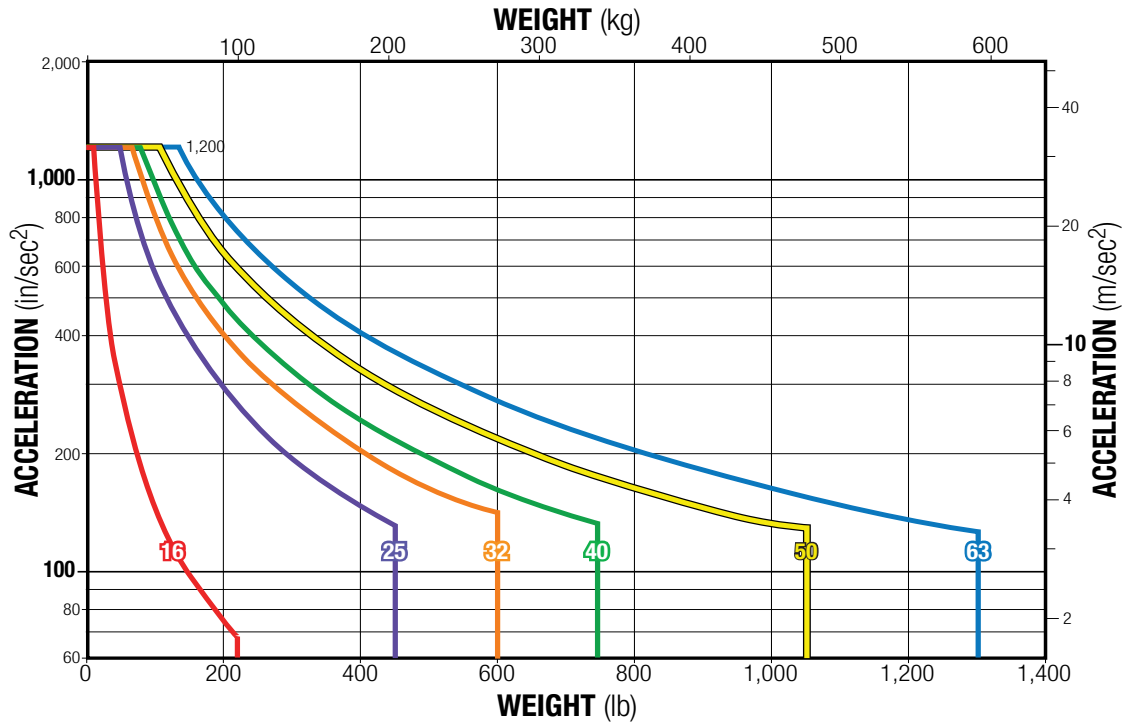

## MOUNTING PLATE REQUIREMENTS (P ONLY)

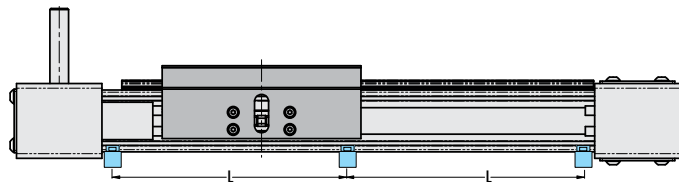
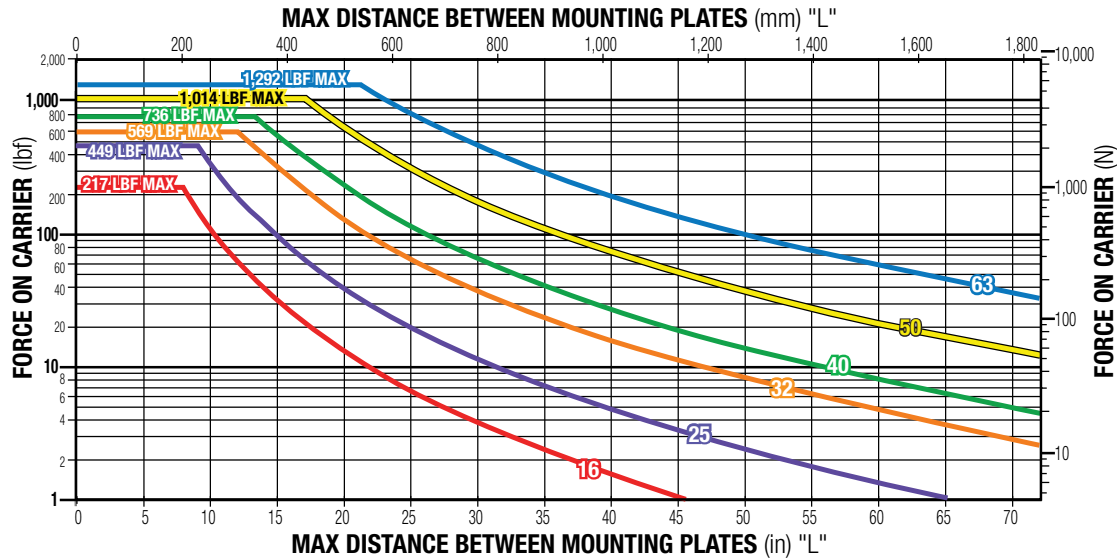

Sold & Serviced By:

**ELECTROMATE**

Toll Free Phone (877) SERV098

Toll Free Fax (877) SERV099

www.electromate.com

sales@electromate.com

# MXB-P Rodless Belt Drive Actuator

## MOMENT AND LOAD CAPACITY

⚠ Mating surface of mounted component must maintain a flatness of at least .0015" [0.040 mm]

### STANDARD CARRIER

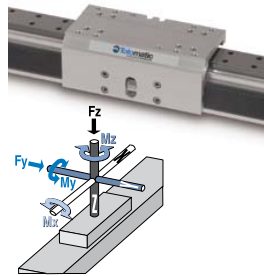

SIZE	MAXIMUM BENDING MOMENTS						MAXIMUM LOAD				MAXIMUM THRUST	
	Mx		My		Mz		Fy		Fz			
	in-lbs	N-m	in-lbs	N-m	in-lbs	N-m	lbf	N	lbf	N	lbf	N
16	39	4.5	339	38.3	339	38.3	217	966	217	966	38	169
25	126	14.3	502	56.7	377	42.6	449	1,996	449	1,996	151	672
32	226	25.6	1,344	152	1,344	152	569	2,531	569	2,531	209	930
40	604	68.2	1,913	216	1,913	216	736	3,274	736	3,274	250	1,112
50	811	91.7	3,483	394	3,483	394	1,014	4,510	1,014	4,510	325	1,446
63	1,019	115	5,339	603	5,339	603	1,292	5,745	1,292	5,745	418	1,859

### AUXILIARY CARRIER

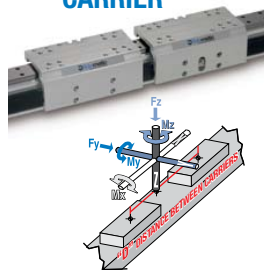

SIZE	"D" MINIMUM		MAXIMUM BENDING MOMENTS*						MAXIMUM LOAD			
	in	mm	Mxa		Mya		Mza		Fya		Fza	
			in-lbs	N-m	in-lbs	N-m	in-lbs	N-m	lbf	N	lbf	N
16	5.0	127	79	8.9	620	70.0	620	70.0	434	1,932	434	1,932
25	6.0	152	252	28.5	1,610	182	1,610	182	898	3,993	898	3,993
32	7.0	178	453	51.1	2,202	249	2,202	249	1,138	5,063	1,138	5,063
40	8.5	216	1,208	136	3,601	407	3,601	407	1,472	6,549	1,472	6,549
50	8.6	218	1,623	183	4,966	561	4,966	561	2,028	9,020	2,028	9,020
63	13.0	330	2,038	230	9,508	1,074	9,508	1,074	2,583	11,490	2,583	11,490

\*At minimum "D" distance - see page MXB\_13 for bending moments at greater distances

⚠ **The above ratings are the maximum values for shock-free, vibration-free operation in a typical industrial environment, which must not be exceeded even in dynamic operation. Contact Tolomatic for assistance in selecting the most appropriate actuator for your application.**

### SPEED FACTOR

FOR APPLICATIONS WITH HIGH SPEED OR SIGNIFICANT SHOCK AND VIBRATION: Calculated values of loads and bending moments must be increased by speed factor from the graph at right to obtain full rated life of profiled rail bearing system.

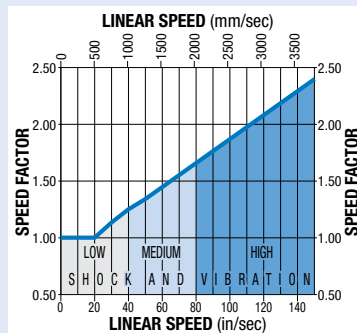

### PROFILED RAIL LUBRICATION

Proper lubrication of profiled rail bearing system is essential for normal operation and achievement of full rated life of MX--P actuators. Lubrication should be performed at intervals of 4,000,000 inches of travel or once every year, whichever occurs first. **However, operating conditions such as high speed or significant shock and vibration may require more frequent lubrication.** Please consult Tolomatic for recommendations.

#### Recommended grease types:

1. Refined mineral oil-based multi-purpose grease with lithium thickening agent.
2. High-grade synthetic oil-based grease with urea thickening agent.

The moment and load capacity of the actuator's bearing system is based on an L10 life of 200,000,000 linear inches of travel. Life of the actuator will vary for each application depending on the combined loads, motion parameters and operating conditions. The load factor ( $L_F$ ) for each application must not exceed a value of 1 (as calculated below). Exceeding a load factor of 1 will diminish the actuator's rated life.

$$L_F = \frac{M_x}{M_{x_{max}}} + \frac{M_y}{M_{y_{max}}} + \frac{M_z}{M_{z_{max}}} + \frac{F_y}{F_{y_{max}}} + \frac{F_z}{F_{z_{max}}} \leq 1$$

With combined loads,  $L_F$  must not exceed the value 1.

Sold & Serviced By:

**ELECTROMATE**

Toll Free Phone (877) SERV098

Toll Free Fax (877) SERV099

www.electromate.com

sales@electromate.com

# MXB-P Rodless Belt Drive Actuator

SIZING SOFTWARE  
AVAILABLE AT WWW.  
TOLOMATIC.COM

## LOAD DEFLECTION

### DEFLECTION TESTING WAS DONE UNDER THESE CRITERIA:

- 1.) Actuator was properly mounted with distance between mounting plates within recommendations
- 2.) Deflection was measured at 12" from center of carrier as shown (see Mounting Plate Requirements page mx\_11)

### DEFLECTION ABOUT X AXIS

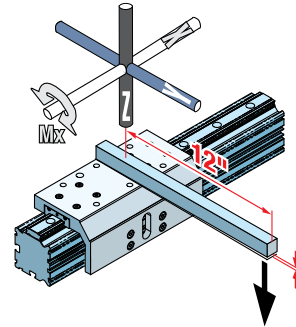
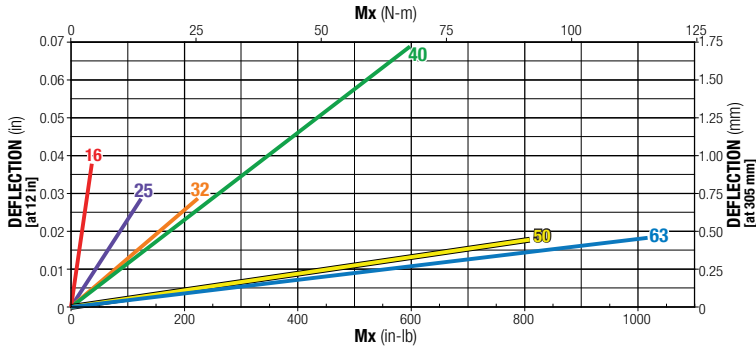

### DEFLECTION ABOUT Y AXIS

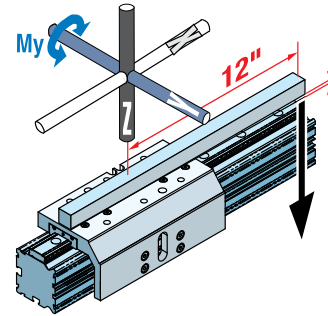
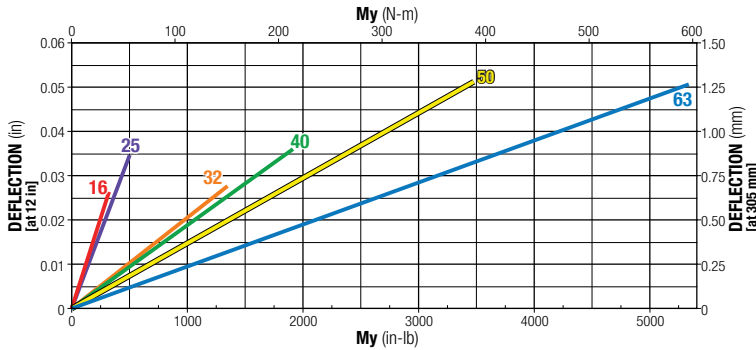

### DEFLECTION ABOUT Z AXIS

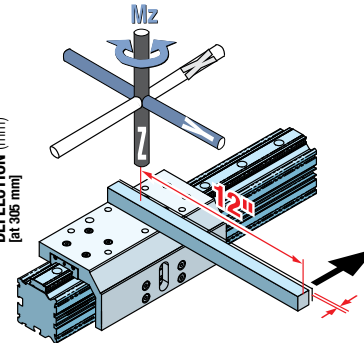
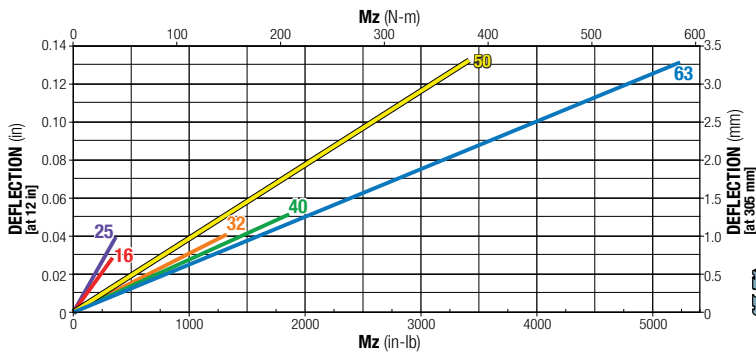

### AUXILIARY CARRIER BENDING MOMENTS WITH INCREASED "D" DISTANCE BETWEEN CARRIERS

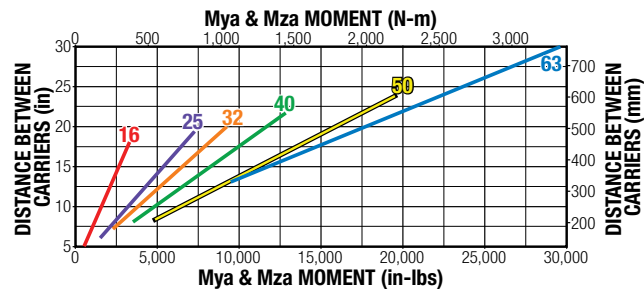

### RATINGS WERE CALCULATED UNDER THESE CRITERIA:

- 1.) Coupling between carriers is rigid.
- 2.) Load is equally distributed between carriers.
- 3.) Coupling device applies no misalignment loads to carriers.

Sold & Serviced By:

**ELECTROMATE**

Toll Free Phone (877) SERV098

Toll Free Fax (877) SERV099

www.electromate.com

sales@electromate.com

# MXB-U Rodless Belt Drive Actuator

## ACTUATOR & OPTION DIMENSIONS

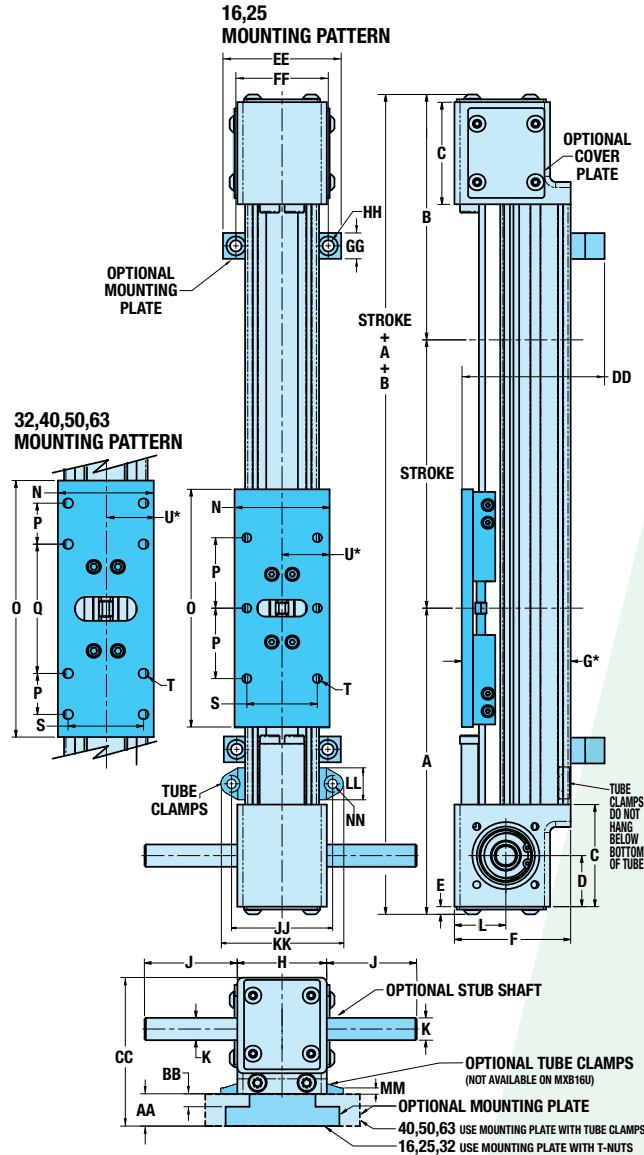

**▲** \*In order for the actuator to operate properly, dimensions "G" and "U" must not vary more than ±0.020 in [0.51mm] over the entire length of the stroke.

** MXB16	
(LMI) J	0.59
mm	15.0
(RP) J	1.83
mm	46.6

### OPTIONAL TUBE CLAMPS

JJ	-	2.24	2.92	3.26	3.84	5.19
mm	-	57.0	74.1	82.7	97.5	131.7
KK	-	2.72	3.44	3.81	4.39	5.93
mm	-	69.0	87.4	96.7	111.5	150.7
LL	-	0.71	0.63	0.55	0.55	0.75
mm	-	18.0	16.0	14.0	14.0	19.0
MM	-	0.14	0.17	0.15	0.15	0.24
mm	-	3.6	4.3	3.8	3.8	6.1
NN	-	0.20	0.28	0.28	0.28	0.42
mm	-	5.2	7.1	7.1	7.1	10.7

	MXB16	MXB25	MXB32	MXB40	MXB50	MXB63
A	5.33	6.85	7.39	8.53	8.85	10.83
mm	135.3	173.9	187.8	216.6	224.7	275.1
B	4.69	5.49	6.09	7.59	8.07	10.33
mm	119.0	139.3	154.7	192.7	205.0	262.1
C	2.00	2.28	2.20	3.10	3.25	3.79
mm	50.8	58.0	55.9	78.7	82.6	96.1
D	1.00	1.14	1.00	1.55	1.58	1.79
mm	25.4	29.0	25.4	39.4	40.0	45.3
E	0.15	0.17	0.17	0.17	0.17	0.17
mm	3.8	4.4	4.4	4.4	4.4	4.4
F	2.08	2.60	3.05	3.69	4.35	5.48
mm	52.8	66.0	77.5	93.8	110.6	139.3
G*	1.77	2.44	3.05	3.48	4.31	5.34
mm	45.3	61.9	77.4	88.3	109.6	135.5
H	1.75	2.00	2.75	3.25	3.88	4.38
mm	44.5	50.8	69.9	82.6	98.4	111.1
J	**	2.27	2.27	1.87	1.87	1.87
mm	**	57.7	57.7	47.5	47.5	47.5
K	0.375	0.500	0.500	0.500	0.500	0.500
mm	09.53	012.70	012.70	012.70	012.70	012.70
L	1.04	1.15	1.10	1.56	1.63	2.06
mm	26.4	29.2	27.9	39.7	41.5	52.2
N	1.38	2.13	2.50	3.50	3.75	4.50
mm	34.9	54.0	63.5	88.9	95.3	114.3
O	4.33	5.31	6.69	7.87	8.50	12.00
mm	110.0	135.0	170.0	200.0	216.0	304.8
P	1.57	1.57	1.07	1.00	1.00	1.57
mm	40.0	40.0	27.1	25.4	25.4	40.0
Q	-	-	3.37	4.50	2.75	5.12
mm	-	-	87.7	114.3	69.8	130.0
S	1.10	1.57	1.97	2.83	3.13	3.87
mm	28.0	40.0	50.0	72.0	79.4	98.3
T	#8-32(6)	1/4-20(6)	5/16-18(8)	5/16-18(8)	5/16-18(8)	3/8-16(8)
mm	M4x0.7	M6x1.0	M8x1.25	M8x1.25	M8x1.25	M10x1.5
U*	0.69	1.07	1.25	1.75	1.88	2.25
mm	17.5	27.0	31.8	44.5	47.7	57.2
<b>OPTIONAL MOUNTING PLATES</b>						
AA	0.63	0.63	0.75	1.00	1.25	1.00
mm	15.9	15.9	19.1	25.4	31.8	25.4
BB	0.25	0.25	0.30	-	-	-
mm	6.4	6.4	7.6	-	-	-
CC	2.71	3.22	3.80	4.70	5.60	6.48
mm	68.7	81.9	96.5	119.4	119.4	164.6
DD	2.4	3.06	3.75	4.18	5.01	6.04
mm	60.9	77.7	95.2	106.1	127.4	153.3
EE	2.36	2.50	3.40	5.00	5.60	8.00
mm	60.0	63.5	86.4	127.0	142.2	203.2
FF	1.75	2.00	2.75	4.41	5.00	7.00
mm	44.5	50.8	59.9	112.0	127.0	177.8
GG	1.00	1.00	1.00	0.79	0.79	1.00
mm	25.4	25.4	25.4	20.1	20.1	25.4
HH	0.22 THRU □0.37 ▽22 (2)	0.22 THRU □0.37 ▽22 (2)	0.28 THRU □0.44 ▽28 (2)	0.28 THRU (2)	0.28 THRU (2)	0.28 THRU (2)
mm	05.6 THRU □09.4 ▽5.6 (2)	05.6 THRU □09.4 ▽5.6 (2)	07.1 THRU □11.2 ▽7.1 (2)	07.1 THRU (2)	07.1 THRU (2)	07.1 THRU (2)

Sold & Serviced By:

**ELECTROMATE**

Toll Free Phone (877) SERV098

Toll Free Fax (877) SERV099

www.electromate.com

sales@electromate.com

# MXB-P Rodless Belt Drive Actuator

## ACTUATOR DIMENSIONS

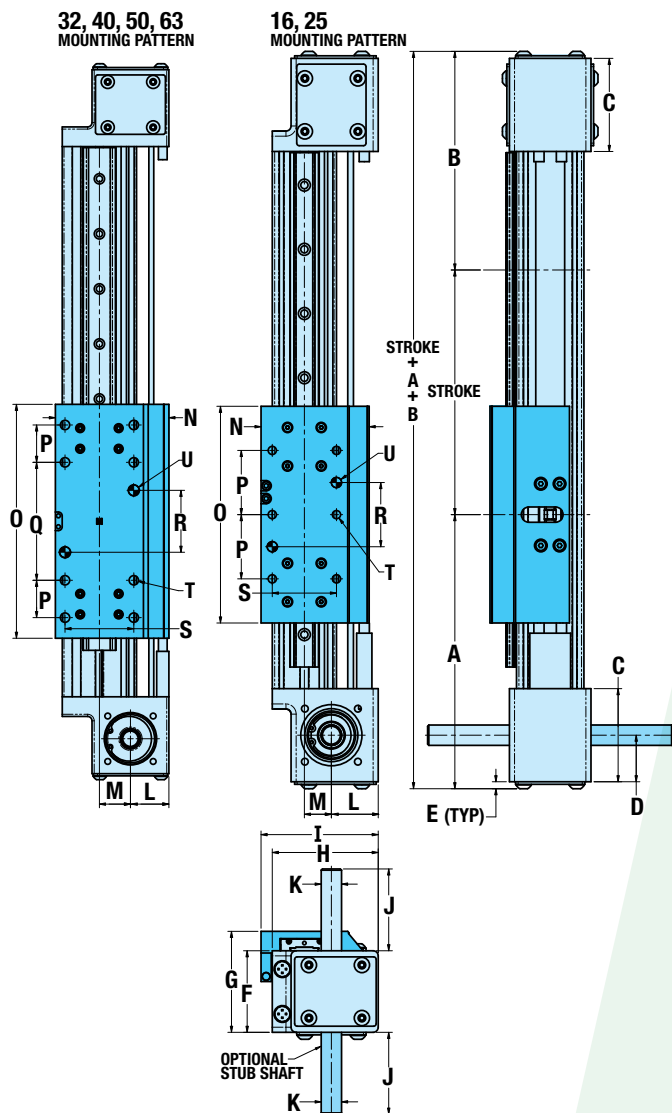

	MXB16	MXB25	MXB32	MXB40	MXB50	MXB63
A	5.33	6.85	7.39	8.53	8.85	10.83
mm	135.3	173.9	187.8	216.6	224.7	275.1
B	4.69	5.49	6.09	7.59	8.07	10.33
mm	119.0	139.3	154.7	192.7	205.0	262.1
C	2.00	2.28	2.20	3.10	3.25	3.79
mm	50.8	58.0	55.9	78.7	82.6	96.1
D	1.00	1.14	1.00	1.55	1.58	1.79
mm	25.4	29.0	25.4	39.4	40.0	45.3
E	0.15	0.17	0.17	0.17	0.17	0.17
mm	3.8	4.4	4.4	4.4	4.4	4.4
F	1.75	2.00	2.75	3.25	3.88	4.38
mm	44.5	50.8	69.9	82.6	98.4	111.1
G	2.10	2.48	3.33	3.88	5.10	5.73
mm	53.2	62.9	84.6	98.7	129.6	145.6
H	2.08	2.60	3.05	3.69	4.35	5.48
mm	52.8	66.0	77.5	93.8	110.6	139.3
I	2.16	2.87	3.25	4.09	4.64	5.79
mm	54.8	73.0	82.5	103.9	117.9	147.1
J	**	2.27	2.27	1.87	1.87	1.87
mm	**	57.7	57.7	47.5	47.5	47.5
K	0.375	0.500	0.500	0.500	0.500	0.500
mm	09.53	012.70	012.70	012.70	012.70	012.70
L	1.04	1.15	1.10	1.56	1.63	2.06
mm	26.4	29.2	27.9	39.7	41.5	52.2
M	0.45	0.66	0.89	0.87	1.17	1.46
mm	11.4	16.8	22.6	22.2	29.8	37.1
N	1.78	2.65	3.25	3.85	4.62	5.93
mm	45.3	67.4	82.5	97.8	117.4	150.6
O	4.33	5.31	6.69	7.87	8.50	12.00
mm	110.0	135.0	170.0	200.0	216.0	304.8
P	1.57	1.57	1.07	1.00	1.00	1.57
mm	40.0	40.0	27.1	25.4	25.4	40.0
Q	—	—	3.37	4.50	2.75	5.12
mm	—	—	87.7	114.3	69.8	130.0
R	1.575	1.575	1.772	2.500	1.500	2.559
mm	40.00	40.00	45.00	63.50	38.10	65.00
S	1.102	1.575	1.969	2.835	3.125	3.870
mm	28.00	40.00	50.00	72.00	79.38	98.30
T	#8-32(6)	1/4-20(6)	5/16-18(8)	5/16-18(8)	5/16-18(8)	3/8-16(8)
mm	M4x0.7	M6x1.0	M8x1.25	M8x1.25	M8x1.25	M10x1.5
U	0.1583 / .1573 (2) ↓.250	0.2520 / .2510 (2) ↓.250	0.3145 / .3135 (2) ↓.375	0.3145 / .3135 (2) ↓.500	0.3145 / .3135 (2) ↓.500	0.3770 / .3760 (2) ↓.500
mm	04.045 / 4.020 ↓ 6.35	06.045 / 6.020 ↓ 6.35	08.045 / .8.020 ↓ 9.53	08.045 / .8.020 ↓ 12.70	08.045 / .8.020 ↓ 12.70	010.045 / 10.020 ↓ 12.70

** MXB16
(LMI) J 0.59
mm 15.0
(RP) J 1.83
mm 46.6

Sold & Serviced By:

**ELECTROMATE**

Toll Free Phone (877) SERV098

Toll Free Fax (877) SERV099

www.electromate.com

sales@electromate.com

# MXB-P Rodless Belt Drive Actuator

## OPTION DIMENSIONS

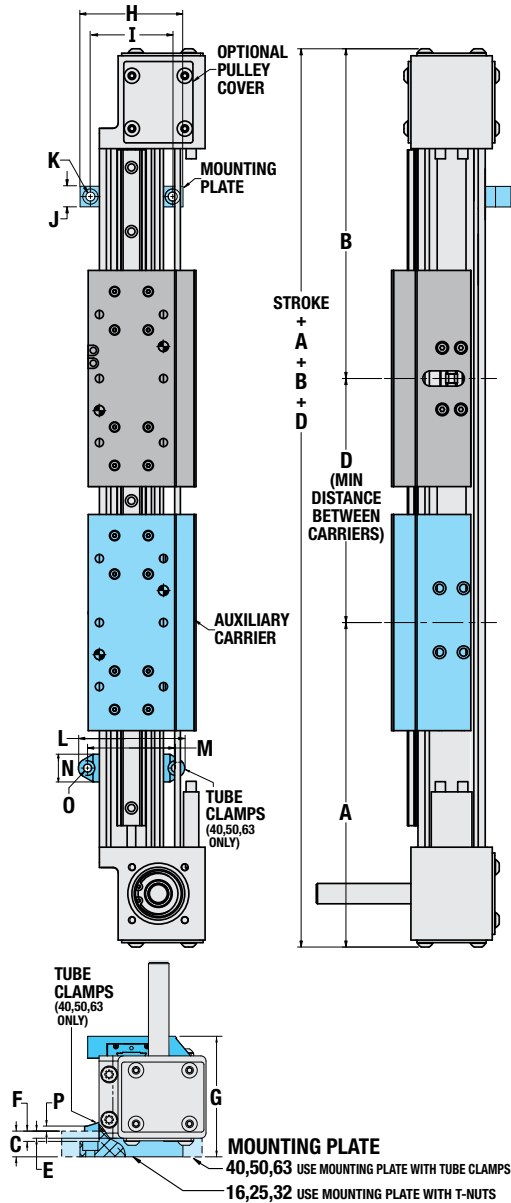

	MXB16	MXB25	MXB32	MXB40	MXB50	MXB63
A	5.33	6.85	7.39	8.53	8.85	10.83
mm	135.3	173.9	187.8	216.6	224.7	275.1
B	4.69	5.49	6.09	7.59	8.07	10.33
mm	119.0	139.3	154.7	192.7	205.0	262.1
<b>AUXILIARY CARRIER</b>						
D	5.00	6.00	7.00	8.50	8.60	13.00
mm	127.0	152.4	177.0	215.9	216.4	330.2
<b>MOUNTING PLATE</b>						
C	0.63	0.63	0.75	1.00	1.25	1.00
mm	15.9	15.9	19.1	25.4	31.8	25.4
E	0.28	0.17	0.29	0.37	0.39	0.22
mm	7.2	4.4	7.2	9.3	9.8	5.6
F	0.25	0.25	0.30	–	–	–
mm	6.4	6.4	7.6	–	–	–
G	2.44	2.93	3.80	4.52	5.96	6.51
mm	61.9	74.4	96.5	114.8	151.4	165.4
H	2.36	2.50	3.40	5.00	5.60	8.00
mm	60.0	63.5	86.4	127.0	142.2	203.2
I	1.75	2.00	2.75	4.41	5.00	7.00
mm	44.5	50.8	69.9	112.0	127.0	177.8
J	1.00	1.00	1.00	0.79	0.79	1.00
mm	25.4	25.4	25.4	20.1	20.1	25.4
K	0.22 THRU └┘ 0.37 ┆ 0.22 (2)	0.22 THRU └┘ 0.37 ┆ 0.22 (2)	0.28 THRU └┘ 0.44 ┆ 0.28 (2)	0.28 THRU (2)	0.28 THRU (2)	0.28 THRU (2)
mm	05.6 THRU └┘ 09.4 ┆ 5.6 (2)	05.6 THRU └┘ 09.4 ┆ 5.6 (2)	07.1 THRU └┘ 11.2 ┆ 7.1 (2)	07.1 THRU (2)	07.1 THRU (2)	07.1 THRU (2)
<b>TUBE CLAMPS</b>						
L	–	–	–	3.81	4.39	5.93
mm	–	–	–	96.8	111.5	150.6
M	–	–	–	3.26	3.84	5.19
mm	–	–	–	82.8	97.5	131.8
N	–	–	–	0.55	0.55	0.75
mm	–	–	–	14.0	14.0	19.1
O	–	–	–	0.28	0.28	0.42
mm	–	–	–	7.1	7.1	10.7
P	–	–	–	0.15	0.15	0.24
mm	–	–	–	3.8	3.8	6.1

Sold & Serviced By:

**ELECTROMATE**

Toll Free Phone (877) SERV098

Toll Free Fax (877) SERV099

www.electromate.com

sales@electromate.com



# MXB Rodless Belt Drive Actuators

## DIRECT DRIVE MOTOR MOUNTING



### MXB-U

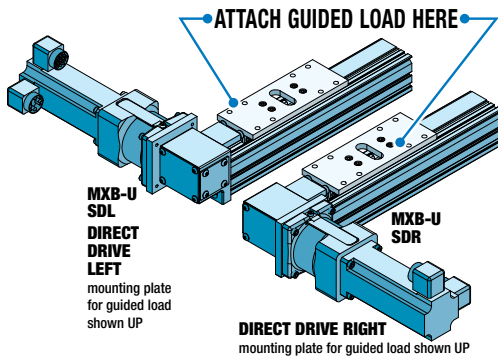

### MXB-P

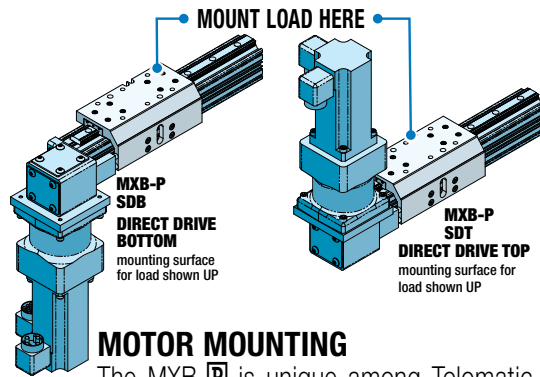

### MOTOR MOUNTING

The MXB-P is unique among Tolomatic belt drive actuators. The mounting surface of the carrier is located 90° from the motion of the belt. The side opposite the belt is reserved for switch placement. The bottom of the actuator is reserved for mounting. If the motor is mounted in the SDT (direct drive top orientation), be sure the load mounted to the carrier does not interfere with the motor.



**LARGE FRAME MOTORS AND SMALLER SIZE ACTUATORS:** Cantilevered motors need to be supported if subjected to continuous rapid reversing duty and/or under dynamic conditions.

## REDUCTION DRIVE MOTOR MOUNTING

### MXB-U

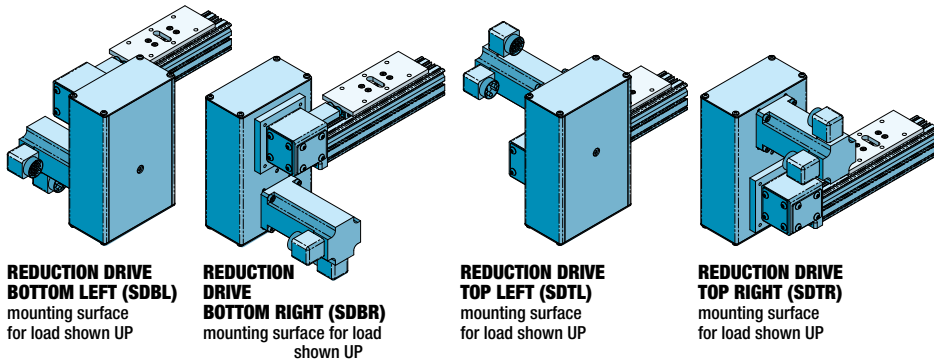

### MXB-P

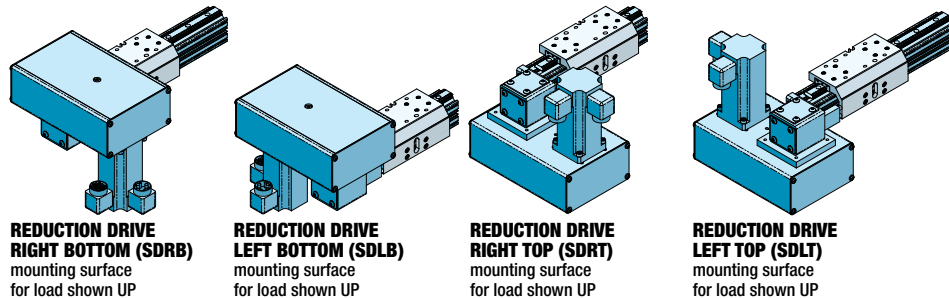

Sold & Serviced By:



Toll Free Phone (877) SERV098  
 Toll Free Fax (877) SERV099  
[www.electromate.com](http://www.electromate.com)  
[sales@electromate.com](mailto:sales@electromate.com)

# MXB-P Rodless Belt Drive Actuator

## SWITCHES SPECIFICATIONS



MX products offer a wide range of sensing choices. There are 12 switch choices: reed, solid state PNP (sourcing) or solid state NPN (sinking); in normally open or normally closed; with flying leads or quick-disconnect.

Commonly used for end-of-stroke positioning, these switches allow drop-in installation anywhere along the entire actuator length. The one-piece design includes the retained fastening hardware. The magnet and magnet hardware are located on the carrier. See the dimensional drawings on page MXB\_19 for details of magnet and switch locations. Switches and magnets can be installed in the field at any time.

Switches are used to send digital signals to PLC (programmable logic controller), TTL, CMOS circuit or other controller device. Switches contain reverse polarity protection. Solid state QD cables are shielded; shield should be terminated at flying lead end.

All switches are CE rated and are RoHS compliant. Switches feature bright red or yellow LED signal indicators; solid state switches also have green LED power indicators.



	Order Code	Part Number	Lead	Switching Logic	Power LED	Signal LED	Operating Voltage	**Power Rating (Watts)	Switching Current (mA max.)	Current Consumption	Voltage Drop	Leakage Current	Temp. Range	Shock / Vibration
REED	R Y	8100-9082	5m	SPST Normally Open	—	Red	5 - 240 AC/DC	**10.0	100mA	—	3.0 V max.	—	14 to 158°F [-10 to 70°C]	50 G / 9 G
	R K	8100-9083	QD*											
	N Y	8100-9084	5m	SPST Normally Closed	—	Yellow	5 - 110 AC/DC							
	N K	8100-9085	QD*											
SOLID STATE	T Y	8100-9088	5m	PNP (Sourcing) Normally Open	Green	Yellow	10 - 30 VDC	**3.0	100mA	20 mA @ 24V	2.0 V max.	0.05 mA max.		
	T K	8100-9089	QD*											
	K Y	8100-9090	5m	NPN (Sinking) Normally Open	Green	Red								
	K K	8100-9091	QD*											
	P Y	8100-9092	5m	PNP (Sourcing) Normally Closed	Green	Yellow								
	P K	8100-9093	QD*											
	H Y	8100-9094	5m	NPN (Sinking) Normally Closed	Green	Red								
	H K	8100-9095	QD*											

\*QD = Quick-disconnect

Enclosure classification IEC 529 IP67 (NEMA 6)

CABLES: Robotic grade, oil resistant polyurethane jacket, PVC insulation

**⚠ \*\*WARNING:** Do not exceed power rating (Watt = Voltage x Amperage). Permanent damage to sensor will occur.

## SWITCH INSTALLATION AND REPLACEMENT

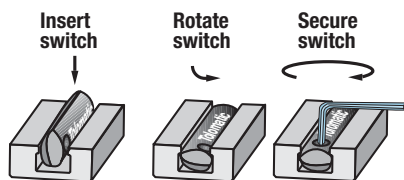

Place switch in side groove on tube at desired location with "Tolomatic" facing outward. While applying light pressure to the switch, rotate the switch halfway into the groove. Maintaining light pressure, rotate the switch in the opposite direction until it is fully inside the groove with "Tolomatic" visible. Re-position the switch to the exact location and lock the switch securely into place by tightening the screw on the switch.

Sold & Serviced By:

**ELECTROMATE**

Toll Free Phone (877) SERV098

Toll Free Fax (877) SERV099

www.electromate.com

sales@electromate.com

# MXB-P Rodless Belt Drive Actuator

## SWITCHES

### WIRING DIAGRAMS

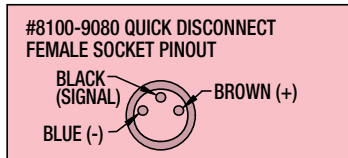
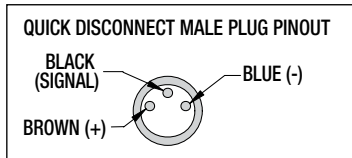
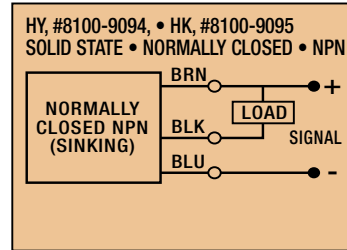
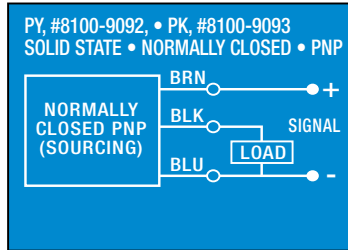
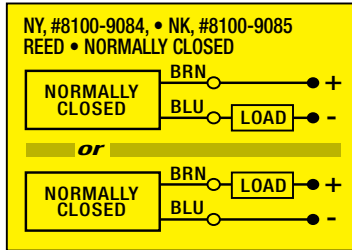
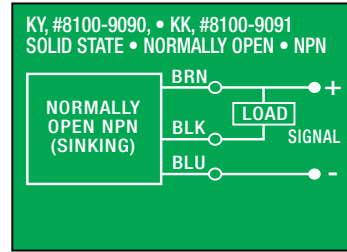
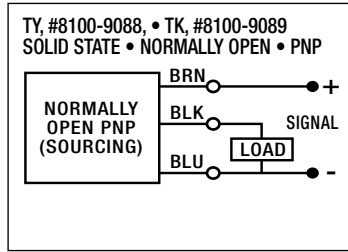
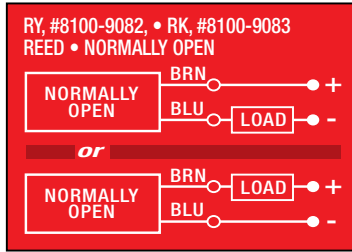

### SWITCH DIMENSIONS

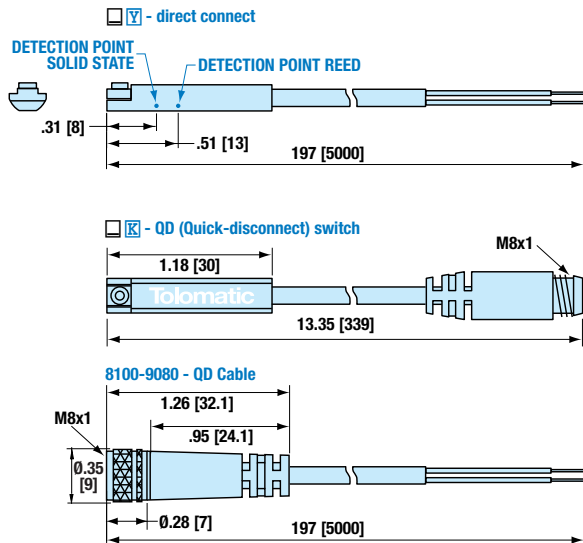

Dimensions in inches [brackets indicate dimensions in millimeters]

### MOUNTING DIMENSIONS

#### MXB-P

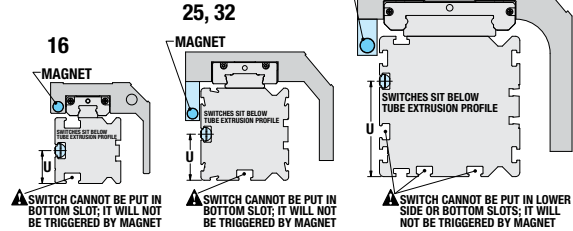

#### MXB-U

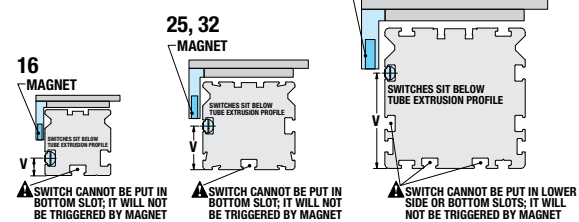

### SWITCH MOUNTING

	16	25	32	40	50	63
U	0.59	0.83	1.09	1.71	2.02	2.44
mm	15.0	21.0	27.7	43.5	51.4	62.0
V	0.31	0.79	1.06	1.71	2.02	2.44
mm	7.9	20.0	27.0	43.5	51.4	62.0

⚠ NOTE: When ordering switches as a service part, Magnet Housing Kit (light blue in drawings) is required if actuator was not originally ordered with switches.

Sold & Serviced By:

**ELECTROMATE**

Toll Free Phone (877) SERV098

Toll Free Fax (877) SERV099

www.electromate.com

sales@electromate.com

# APPLICATION DATA WORKSHEET Fill in known data. Not all information is required for all applications

## ORIENTATION

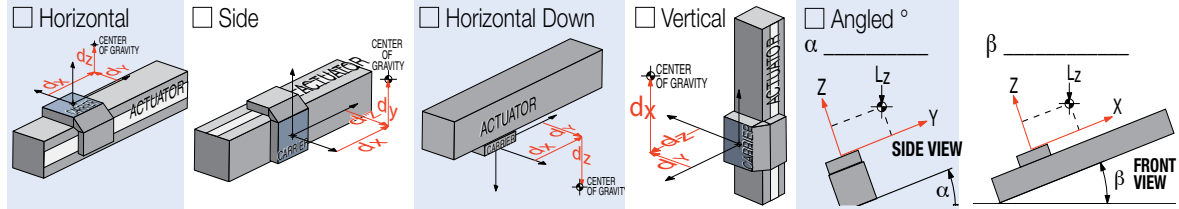

Load attached to carrier OR  Load supported by other mechanism

## DISTANCE FROM CENTER OF CARRIER TO LOAD CENTER OF GRAVITY

$d_x$  \_\_\_\_\_  
 $d_y$  \_\_\_\_\_  
 $d_z$  \_\_\_\_\_

inch (U.S. Standard)  millimeters (Metric)

## STROKE LENGTH

inch (S/I) (U.S. Standard)  millimeters (S/M) (Metric)

**▲** NOTE: If load or force on carrier changes during cycle use the highest numbers for calculations

## LOAD

lb. (U.S. Standard)  kg. (Metric)

## FORCES APPLIED TO CARRIER

lbf. (U.S. Standard)  N (Metric)

$F_z$  \_\_\_\_\_  
 $F_y$  \_\_\_\_\_

## BENDING MOMENTS APPLIED TO CARRIER

$M_x$  \_\_\_\_\_  
 $M_y$  \_\_\_\_\_  
 $M_z$  \_\_\_\_\_  
 in.-lbs. (U.S. Standard)  N-m (Metric)

## PRECISION

Repeatability \_\_\_\_\_  
 inch  millimeters

## OPERATING ENVIRONMENT

Temperature, Contamination, etc.

## MOVE PROFILE

Move Distance \_\_\_\_\_

inch  millimeters

Dwell Time After Move \_\_\_\_\_

Max. Speed \_\_\_\_\_

in/sec  mm/sec

## MOVE TIME

sec

## NO. OF CYCLES

per minute  per hour

## MOTION PROFILE

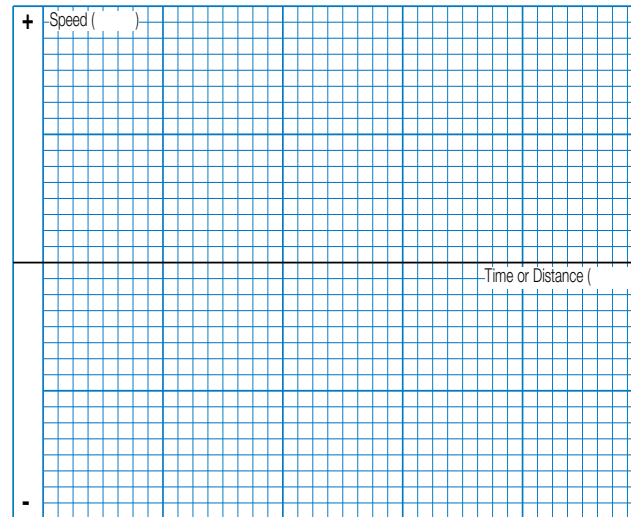

Graph your most demanding cycle, including accel/decel, velocity and dwell times. You may also want to indicate load variations and I/O changes during the cycle. Label axes with proper scale and units.

## CONTACT INFORMATION

Name, Phone, Email  
Co. Name, Etc.

Sold & Serviced By:



Toll Free Phone (877) SERV098

Toll Free Fax (877) SERV099

www.electromate.com

sales@electromate.com

# SELECTION GUIDELINES

The process of selecting a belt drive actuator for a given application can be complex. **It is highly recommended that you contact Tolomatic or a Tolomatic distributor for assistance in selecting the best actuator for your application.** The following overview of the selection guidelines are for educational purposes only.

## 1 CHOOSE ACTUATOR SIZE

Choose an actuator that has the thrust, speed and moment load capacity to move the load.

- A) For maximum thrust use the table below.
- B) Maximum speed of MXB-U 200 in/sec (5 m/sec); Maximum speed of MXB-P 150 in/sec (3.8 m/sec).
- C) For MXB-P moment and load capacities see tables on page [MXB\\_12](#).

SIZE	MAXIMUM THRUST	
	lbf	N
16	38	169
25	151	672
32	209	930
40	250	1112
50	325	1446
63	418	1859

## 2 COMPARE LOAD TO MAXIMUM LOAD CAPACITIES

Calculate the application load (combination of load mass and forces applied to the carrier) and application bending moments (sum of all moments  $M_x$ ,  $M_y$ , and  $M_z$  applied to the carrier). Be sure to evaluate the magnitude of dynamic inertia moments. When a rigidly attached load mass is accelerated or decelerated, its inertia induces bending moments on the carrier. Careful attention to how the load is decelerated at the end of the stroke is required for improved actuator performance and application safety. If either load or any of the moments exceed figures indicated in the Moment and Load Capacity tables (page [MXB\\_12](#)) for the actuator consider:

- 1) A larger actuator size
- 2) Auxiliary carrier
- 3) External guide system (if the load is externally supported and guided, consider using MXB-U)

## 3 CALCULATE LOAD FACTOR (LF)

For loads with a center of gravity offset from the carrier account for both applied (static) and dynamic loads. The load factor (LF) must not exceed the value of 1.

$$L_f = \frac{M_x}{M_{x_{max}}} + \frac{M_y}{M_{y_{max}}} + \frac{M_z}{M_{z_{max}}} + \frac{F_y}{F_{y_{max}}} + \frac{F_z}{F_{z_{max}}} \leq 1$$

If  $L_f$  does exceed the value of 1, consider the three choices listed in step #2.

## 4 ESTABLISH YOUR MOTION PROFILE AND CALCULATE ACCELERATION RATE

Using the application stroke length and maximum carrier velocity (or time to complete the linear motion), establish the motion profile. Select either triangular (accel-decel) or trapezoidal (accel-constant speed-decel) profile. Now calculate the maximum acceleration and deceleration rates of the move. Acceleration/deceleration should not exceed 1200 in/sec<sup>2</sup> (30.48 m/sec<sup>2</sup>). Also, do not exceed safe rates of dynamic inertia moments determined in step #3.

## 5 SELECT MOTOR (GEARHEAD IF NECESSARY) AND DRIVE

To help select a motor and drive, use the sizing equations located in the Engineering Resources section of the Tolomatic Electric Products Catalog (#3600-4609) to calculate the application thrust and torque requirements. Refer to Motor sections to determine the motor and drive.

## 6 DETERMINE MOUNTING PLATE REQUIREMENTS

- Consult the Mounting Plate Requirements graph for the model selected (page [MXB\\_11](#))
- Cross reference the application load and maximum distance between supports
- Select the appropriate number of mounting plates

## 7 CONSIDER OPTIONS

- Choose metric or inch (U.S. standard) load mounting. When ordering use **SIX** for inch and **SIM** for metric.
- Switches - Reed, Solid State PNP or NPN, all available normally open or normally closed

### SPEED FACTOR

FOR APPLICATIONS WITH HIGH SPEED OR SIGNIFICANT SHOCK AND VIBRATION: Calculated values of loads and bending moments must be increased by speed factor from the graph below to obtain full rated life of profiled rail bearing system.

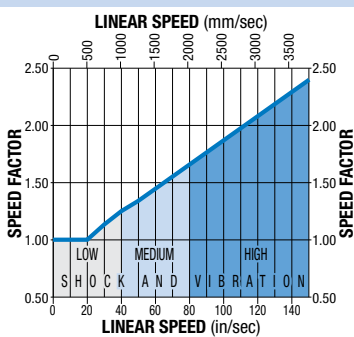

Sold & Serviced By:

**ELECTROMATE**

Toll Free Phone (877) SERV098

Toll Free Fax (877) SERV099

[www.electromate.com](http://www.electromate.com)

[sales@electromate.com](mailto:sales@electromate.com)

# MXB Rodless Belt Drive Actuators

## SERVICE PARTS ORDERING

### SWITCHES

Switches for MXB include retained mounting hardware and are the same for all actuator sizes and bearing styles

Code	Part Number	Lead	Normally	Sensor Type
<b>R</b> <b>Y</b>	8100-9082	5m (197 in)	Open	Reed
<b>R</b> <b>K</b>	8100-9083*	Quick-disconnect		
<b>N</b> <b>Y</b>	8100-9084	5m (197 in)	Closed	Reed
<b>N</b> <b>K</b>	8100-9085*	Quick-disconnect		
<b>T</b> <b>Y</b>	8100-9088	5m (197 in)	Open	Solid State PNP
<b>T</b> <b>K</b>	8100-9089*	Quick-disconnect		
<b>K</b> <b>Y</b>	8100-9090	5m (197 in)	Open	Solid State NPN
<b>K</b> <b>K</b>	8100-9091*	Quick-disconnect		
<b>P</b> <b>Y</b>	8100-9092	5m (197 in)	Closed	Solid State PNP
<b>P</b> <b>K</b>	8100-9093*	Quick-disconnect		
<b>H</b> <b>Y</b>	8100-9094	5m (197 in)	Closed	Solid State NPN
<b>H</b> <b>K</b>	8100-9095*	Quick-disconnect		

\*Also order mating QD cable #8100-9080

	8100-9080	Mating QD (Quick-disconnect) cable 197 in. (5m)
--	-----------	---

**▲** NOTE: When ordering switches as service part, Magnet Housing Kit is required if actuator was not originally ordered with switches

### OPTIONS

ACTUATOR SIZE	Mounting Plate Kit	**MXB-U Magnet Housing Kit	**MXB-P Magnet Housing Kit
16	8316-9016	8516-9024	8340-1008
25	8525-9030	8525-9024	8525-9009
32	8532-9030	8525-9024	8532-9009
40	8340-9017	8525-9024	8540-9009
50	8350-9016	8550-9024	8550-9009
63	8363-9016	8550-9024	8563-9009

\*\*\*Magnet Housing Kit is required if actuator was not originally ordered with switches

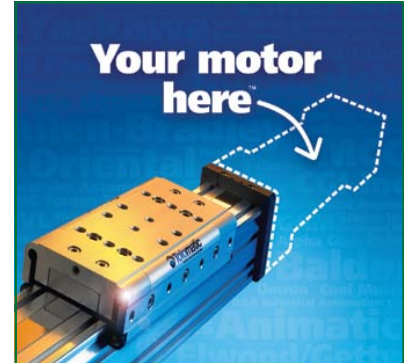

### CUSTOM MOTOR MOUNTS. FIFTEEN DAYS. NO CHARGE.

• Select a high-performance Tolomatic electric actuator and we'll provide a motor-specific interface for YOUR motor - at NO EXTRA CHARGE. With our online database, you can select from over 60 motor manufacturers and hundreds of models.

Visit [www.tolomatic.com/ymh](http://www.tolomatic.com/ymh) today to find your motor/actuator match!

OR

### Select a complete system from tolomatic



• Motors • Drives • Controllers • Gearboxes

*Tolomatic offers digital servo or stepper drives with motors matched to provide optimal performance with Tolomatic actuators.*

**CONFIGURE AN ACTUATOR AND A COMPLETE MOTION CONTROL SYSTEM TODAY USING TOLOMATIC'S EASY-TO-USE ON-LINE SIZING & SELECTION**

Sold & Serviced By:

**ELECTROMATE**

Toll Free Phone (877) SERV098

Toll Free Fax (877) SERV099

[www.electromate.com](http://www.electromate.com)

[sales@electromate.com](mailto:sales@electromate.com)

# MXB Rodless Belt Drive Actuators

## ORDERING

MODEL SELECTION (MUST BE IN THIS ORDER)

**MXB** **40** **P** **BWS** **30** **SM** **2007** **02**

OPTIONS (IN ANY ORDER)

**SDB** **DC** **215** **9** **MP** **8** **HC** **2** **TK** **2**

**MODEL**  
MXB MX Rodless Belt Drive Actuators

**SERIES**

16 Series actuator	40 Series actuator
25 Series actuator	50 Series actuator
32 Series actuator	63 Series actuator

**BEARING**

**U** Unguided Carrier  
**P** Profiled Rail

**BELT MATERIAL AND WIDTH**

**BWS10** 10 mm Urethane Steel (MXB16)  
**BWS18** 18 mm Urethane Steel (MXB25)  
**BWS25** 25 mm Urethane Steel (MXB32)  
**BWS30** 30 mm Urethane Steel (MXB40)  
**BWS40** 40 mm Urethane Steel (MXB50)  
**BWS50** 50 mm Urethane Steel (MXB63)

**STROKE LENGTH & MOUNTING TYPE**

**SK** \_\_\_\_\_ Stroke, enter desired stroke length in **inches**

**SM** \_\_\_\_\_ Stroke, enter desired stroke length in **millimeters**

**GPB** Blank Plate (MXB-U only)  
NO MOUNTING HOLES allowing user to drill and tap as needed

**NOTE: Actuator mounting threads and mounting fasteners will be either inch or metric, depending on how stroke length is indicated**

**SK=inch mounting**  
**SM= metric mounting**

### U MOTOR MOUNTING / REDUCTION

(must choose one)

**SDL, SDLD\*** Direct Drive on Left  
**SDR, SDRD\*** Direct Drive on Right

**▲** A motor size and code must be selected when specifying a 3:1 reduction. Reference the motor ordering pages in Electric Products Catalog #3600-4609.

**SDTL, SDTLD\*** 3:1 Reduction on Top Left  
**SDTR, SDTRD\*** 3:1 Reduction on Top Right  
**SDBL, SDBLD\*** 3:1 Reduction on Left Bottom  
**SDBR, SDBRD\*** 3:1 Reduction on Right Bottom  
*\*For Dual Stub Shaft Option*

### P MOTOR MOUNTING / REDUCTION

(must choose one)

**SDT, SDTD\*** Direct Drive on Top  
**SDB, SDBD\*** Direct Drive on Bottom

**▲** A motor size and code must be selected when specifying a 3:1 reduction. Reference the motor ordering pages in Electric Products Catalog #3600-4609.

**SDLT, SDLTD\*** 3:1 Reduction on Left Top  
**SDRT, SDRTD\*** 3:1 Reduction on Right Top  
**SDLB, SDLBD\*** 3:1 Reduction on Left Bottom  
**SDRB, SDRBD\*** 3:1 Reduction on Right Bottom  
*\*For Dual Stub Shaft Option*

### AUXILIARY CARRIER

**DC** \_\_\_\_\_ Auxiliary Carrier, (MXB-P only) enter center-to-center spacing desired in **inches** (SK) or **millimeters** (SM)

(Same unit of measure as stroke length is required)  
**▲** Center-to-center spacing between carriers adds to overall length of the actuator, this distance will not be subtracted from stroke length specified in the previous step

### HEAD COVER PLATES

**HC2** Head Cover Plates

### MOUNTING

**MP** \_ Mounting Plates, & quantity  
**TC** \_ Tube Clamps, & quantity  
*NOTE: The MXB requires Mounting Plates to allow clearance for motor when mounted flush to surface. 16,25,32 sizes use T-Nuts with Mounting Plates. 40,50,63 sizes use Tube Clamps with Mounting Plates.*

### MOTOR / DRIVE / CONTROLLER / PLANETARY GEARBOX

**▲** Reference the ordering pages in Electric Products Catalog #3600-4609 Stepper Products Brochure #3600-4160 & Planetary Gearbox Doc. #3600-4161

### SWITCHES

TYPE	LOGIC	NORMALLY	QUICK-DISCONNECT	CODE	QUANTITY	LEAD LENGTH
REED	SPST	Open	no	<b>RY</b>	After code enter quantity desired	5 meters (16.4 feet)
			QD	<b>RK</b>		
		Closed	no	<b>NY</b>		
			QD	<b>NK</b>		
SOLID STATE	PNP	Open	no	<b>TY</b>		
			QD	<b>TK</b>		
	NPN	Open	no	<b>KY</b>		
			QD	<b>KK</b>		
PNP	Closed	no	<b>PY</b>			
		QD	<b>PK</b>			
NPN	Closed	no	<b>HY</b>			
		QD	<b>HK</b>			

Sold & Serviced By:



Toll Free Phone (877) SERV098  
Toll Free Fax (877) SERV099  
www.electromate.com  
sales@electromate.com