

MXB RODLESS BELT DRIVE ACTUATORS

ENDURANCE TECHNOLOGYSM

U UNGUIDED

S SOLID BEARING

P PROFILED RAIL



LINEAR SOLUTIONS MADE EASY

MXB Rodless Belt Drive Actuators

DESIGNED TO OUTLAST EVERY BELT DRIVE ACTUATOR ON THE MARKET



The MXB belt drive electric actuator is exactly what you would expect from the industry's number one rodless supplier. Designed with our exclusive **ENDURANCE TECHNOLOGY** features, the MXB delivers superior performance to meet the most demanding applications. Nobody knows rodless like Tolomatic, and the MXB proves it.

- MXB-**U**, MXB-**S** & MXB-**P**: Low profile to fit your application
- MXB-**S**: Engineered bearing material in trapezoidal shape for less wear, low static & dynamic friction
- MXB-**P**: High precision bearings feature smooth, low breakaway motion
- MXB-**P**: Durable profiled rail design uses recirculating ball technology to reduce friction and extend actuator life.
- MXB-**P**: High load and bending moment capacities

TOLOMATIC'S ELECTRIC RODLESS BELT-DRIVE ACTUATORS

	MXB-U	MXB-S	MXB-P	B3W	TKB
Speed up to:	200 in/sec [5,080 mm/sec]	100 in/sec [2,540 mm/sec]	150 in/sec [3,810 mm/sec]	200 in/sec [5,080 mm/sec]	100 in/sec [2,540 mm/sec]
Stroke Length up to:	200 in [5,080 mm]	200 in [5,080 mm]	200 in [5,080 mm]	207 in [5,258 mm]	96 in [2,438 mm]
Load up to:	NA	520 lb [236 kg; 2,313 N]	1,292 lb [586 kg; 5,745 N]	2,008 lb [911 kg; 8,932 N]	750 lb [340 kg; 8,932 N]
Thrust up to:	418 lbf [1,859 N]	418 lbf [1,859 N]	418 lbf [1,859 N]	325 lbf [1,446 N]	245 lbf [1,090 N]
Literature Number:	8500-4000	8500-4000	8500-4000	3600-4609	2700-4000

(Not all models deliver maximum values listed, i.e.: Maximum thrust may not be available with maximum speed)

MXB Rodless Belt Drive Actuators

APPLICATIONS

X-Y Multi-Axis

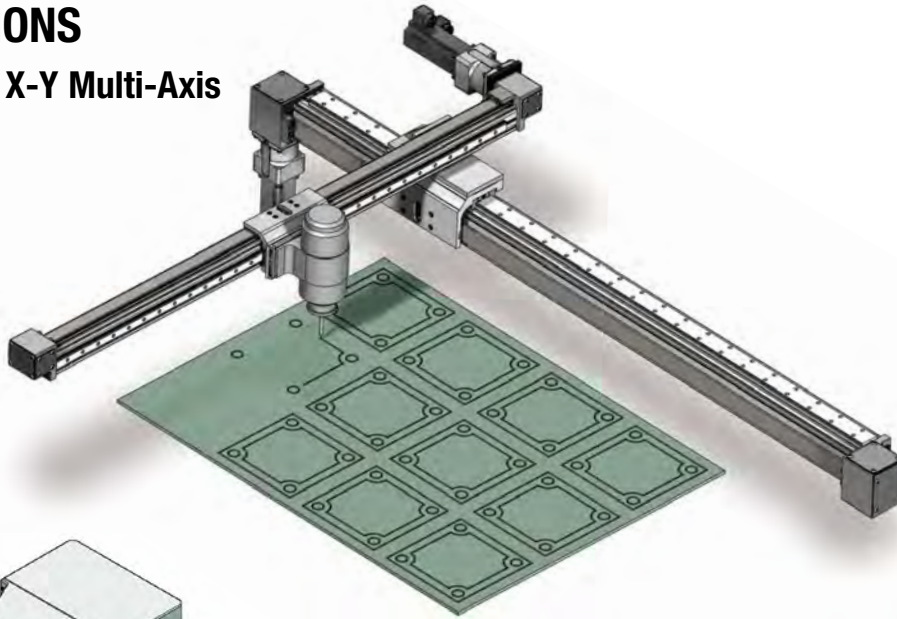

Workcenter Positioning

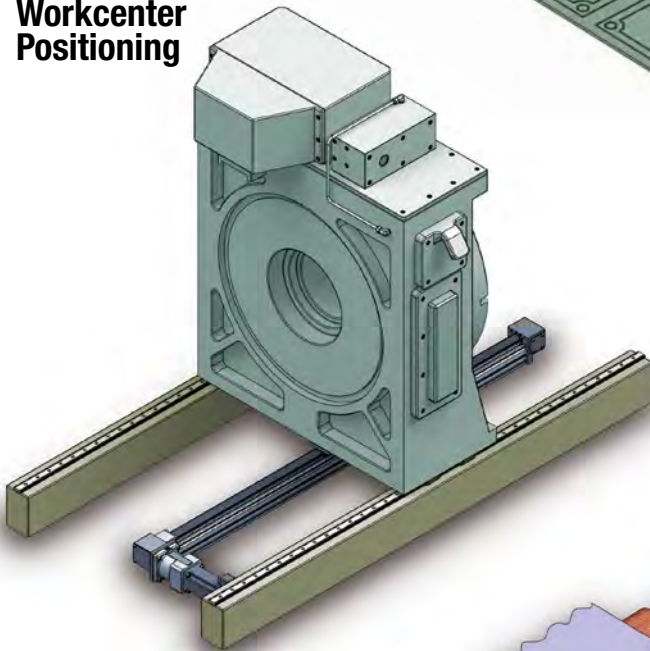

High Speed Flying Cut Off

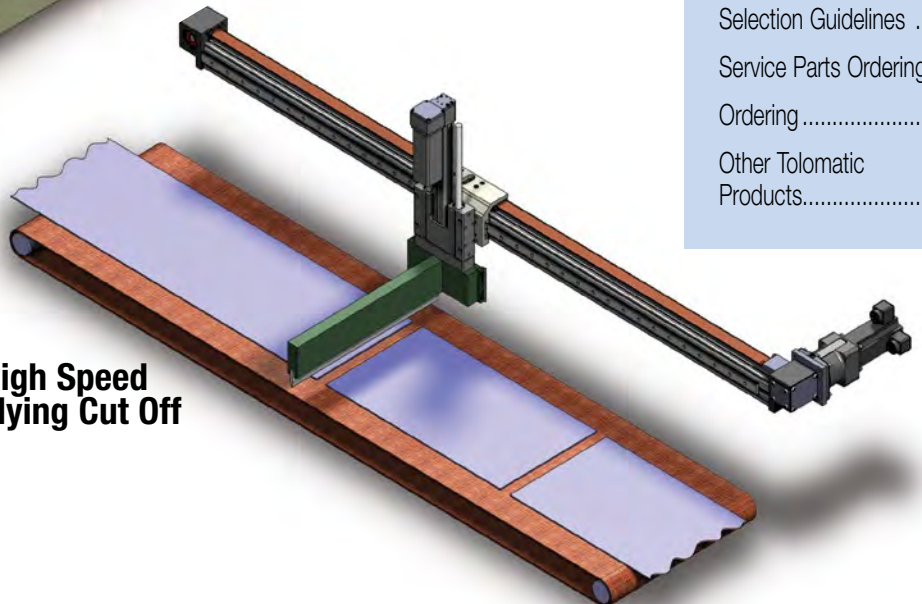

CONTENTS

- MXB Belt Drive Actuator.. 2
- Applications..... 3
- MXB-U Features..... 4
- MXB-S Features 6
- MXB-P Features 8
- Specifications 10
- MXB-U Actuator and Options Dimensions 15
- MXB-S Actuator Dimensions..... 16
- MXB-S Option Dimensions..... 17
- MXB-P Actuator Dimensions..... 18
- MXB-P Option Dimensions..... 19
- Motor Mounting 20
- Switches 22
- Application Data Worksheet 24
- Selection Guidelines 25
- Service Parts Ordering... 26
- Ordering 27
- Other Tolomatic Products..... 28

- Adhesive dispensing
- Camera positioning
- Laser marking
- Pick & place
- Spraying
- Aligning
- Conveyors
- Material cutting
- Positioning
- Stacking
- Animation
- Cutting
- Milling
- Product handling
- Table positioning
- Assembly
- Diverters
- Packaging equipment
- Slitting
- Test stations
- Automotive
- Inspection
- Parts transfer
- Sorting
- Wire winding

MXB-U UNGUIDED BELT DRIVE ACTUATOR

ENDURANCE TECHNOLOGYSM

Endurance TechnologySM features are designed for maximum durability to provide extended service life.

The MXB-U rodless style actuator is a pre-assembled compact linear belt solution for use in applications with existing guides & supports. This economical actuator features speeds up to 200 in/sec and thrusts up to 418 lbf. Built-to-order in stroke lengths up to 200 inches.

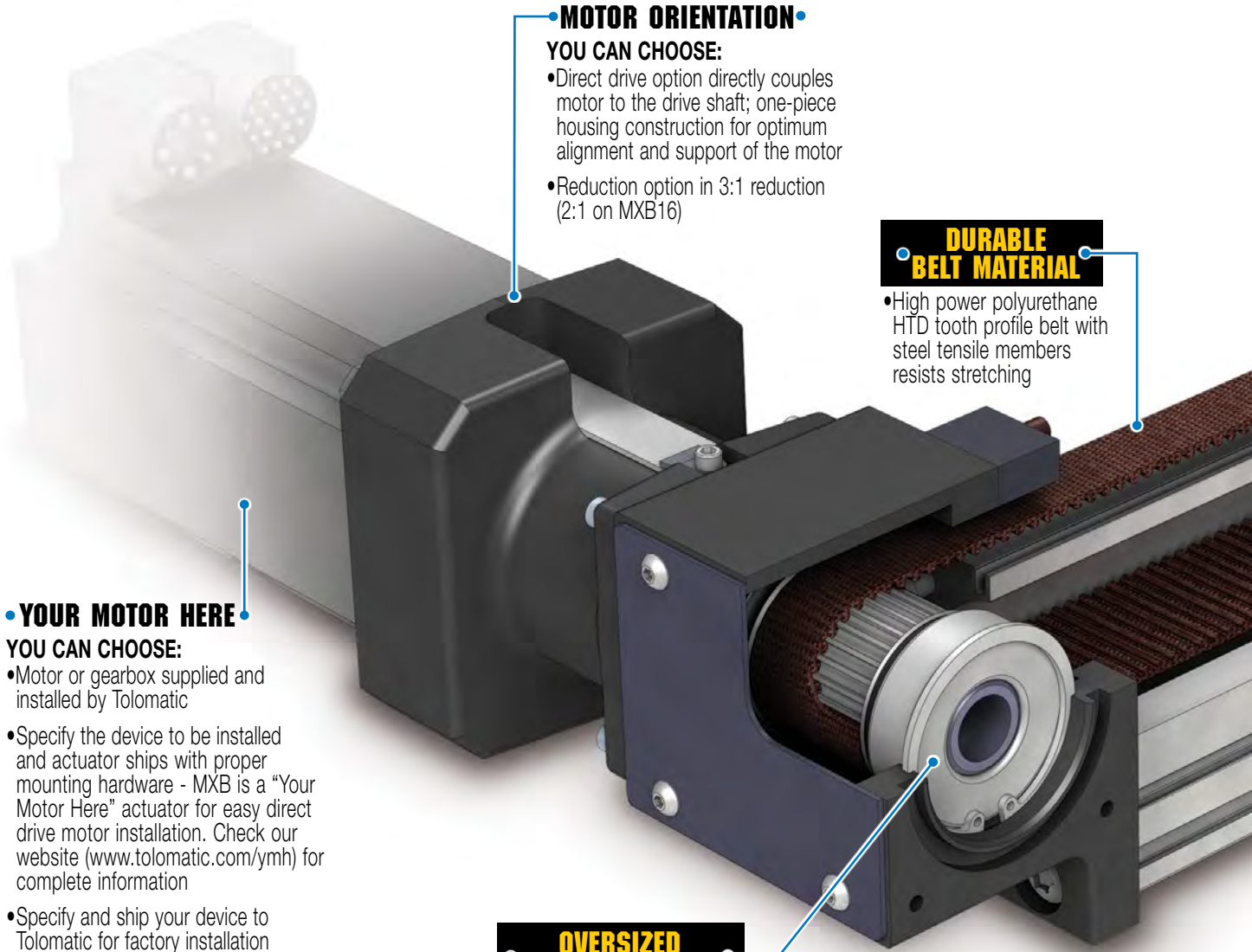

MOTOR ORIENTATION

YOU CAN CHOOSE:

- Direct drive option directly couples motor to the drive shaft; one-piece housing construction for optimum alignment and support of the motor
- Reduction option in 3:1 reduction (2:1 on MXB16)

DURABLE BELT MATERIAL

- High power polyurethane HTD tooth profile belt with steel tensile members resists stretching

OVERSIZED PULLEY BEARINGS

- Drive shaft assembly incorporates oversized shielded/sealed ball bearings for long life and high speeds

YOUR MOTOR HERE

YOU CAN CHOOSE:

- Motor or gearbox supplied and installed by Tolomatic
- Specify the device to be installed and actuator ships with proper mounting hardware - MXB is a "Your Motor Here" actuator for easy direct drive motor installation. Check our website (www.tolomatic.com/ymh) for complete information
- Specify and ship your device to Tolomatic for factory installation

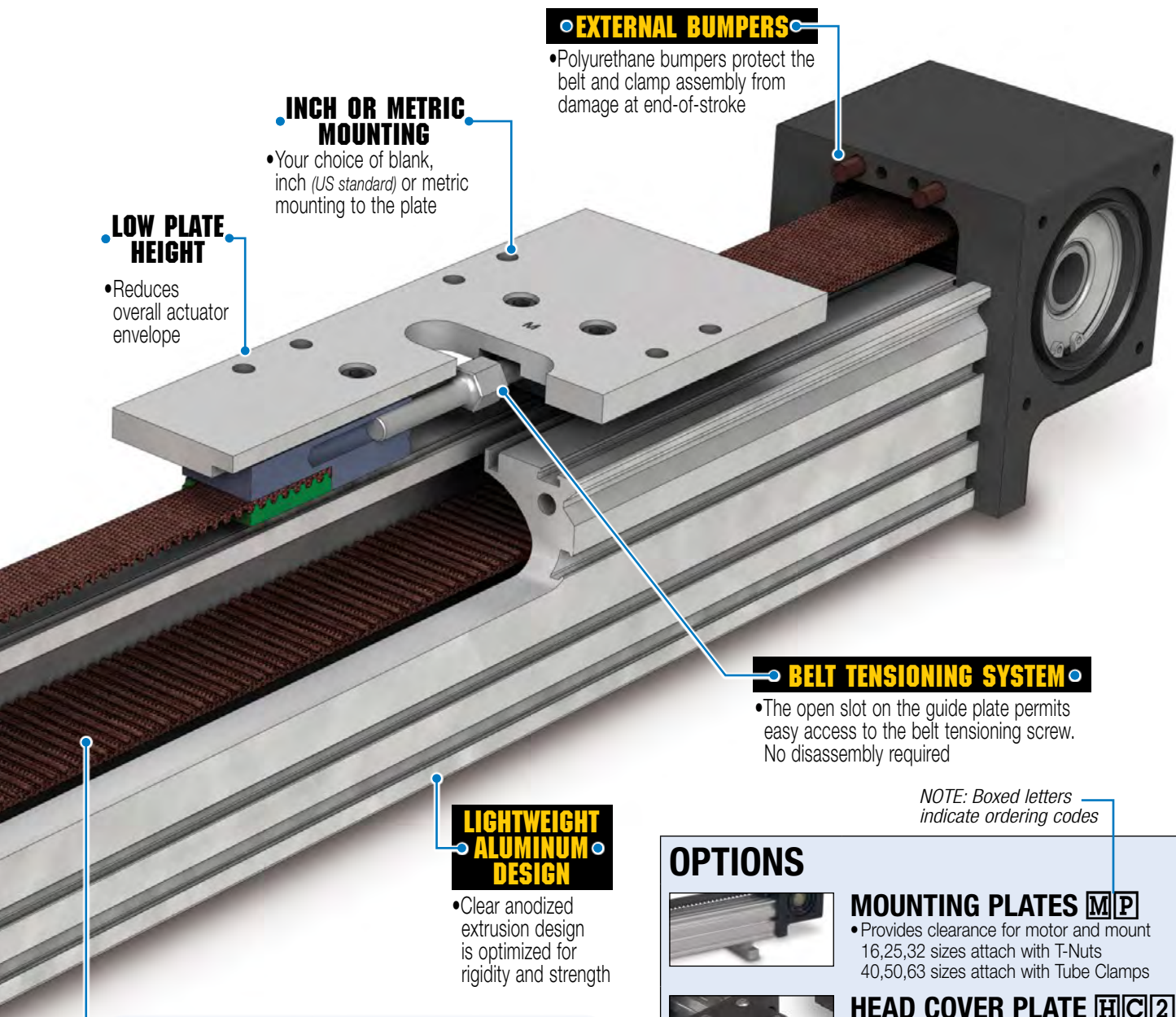

EXTERNAL BUMPERS

- Polyurethane bumpers protect the belt and clamp assembly from damage at end-of-stroke

INCH OR METRIC MOUNTING

- Your choice of blank, inch (US standard) or metric mounting to the plate

LOW PLATE HEIGHT

- Reduces overall actuator envelope

BELT TENSIONING SYSTEM

- The open slot on the guide plate permits easy access to the belt tensioning screw. No disassembly required

LIGHTWEIGHT ALUMINUM DESIGN

- Clear anodized extrusion design is optimized for rigidity and strength

NOTE: Boxed letters indicate ordering codes

STEEL REINFORCED/HTD BELT PROFILE

- Belt of polyurethane material reinforced with steel tension members to produce high carrier thrusts without belt stretch.
- HTD tooth profile distributes tooth load more evenly and provides greater tooth shear strength, allowing for higher thrust loading.
- The deep teeth of the HTD profile are cogging-resistant, preventing potentially damaging positioning errors.

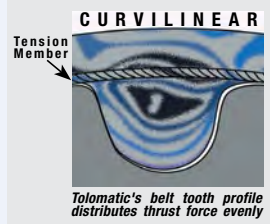

OPTIONS



MOUNTING PLATES **M**P****

- Provides clearance for motor and mount
- 16,25,32 sizes attach with T-Nuts
- 40,50,63 sizes attach with Tube Clamps



HEAD COVER PLATE **H**C****2****

- Provides protection for pulley and bearing



TUBE CLAMPS **T**C****

- Used for intermediate support
- Flush with bottom of actuator to retain low profile
- Drop-in, adjustable mounting locations (Not available on the MXB16U)



SWITCHES

- Wide variety of sensing choices: Reed, Solid State PNP or NPN, available normally open or normally closed
- Flush mount, drop-in installation
- Bright LEDs, power & signal indication
- CE rated, RoHS compliant

MXB-S SOLID BEARING BELT DRIVE

ENDURANCE TECHNOLOGYSM

Endurance TechnologySM features are designed for maximum durability to provide extended service life.

The MXB-S rodless style actuator is a compact linear belt solution for use in applications requiring light to moderate load carrying and guidance. The MXB-S actuator utilizes two field replaceable solid bearings that optimize stress distribution for optimal performance, rigidity and life. This economical actuator features speeds up to 100 in/sec and thrusts up to 418 lbf. Built-to-order in stroke lengths up to 200 inches.

LIGHTWEIGHT ALUMINUM DESIGN

- Clear anodized extrusion design is optimized for rigidity and strength

EXTERNAL BUMPERS

- Polyurethane bumpers protect the belt and clamp assembly from damage at end-of-stroke

BELT TENSIONING SYSTEM

- The open slot on the guide plate permits easy access to the belt tensioning screw. No disassembly required

LARGE FLEXIBLE MOUNTING PATTERN

- Carrier gives more load stability
- Directly compatible with existing BCS & BC2 applications
- More fastening options

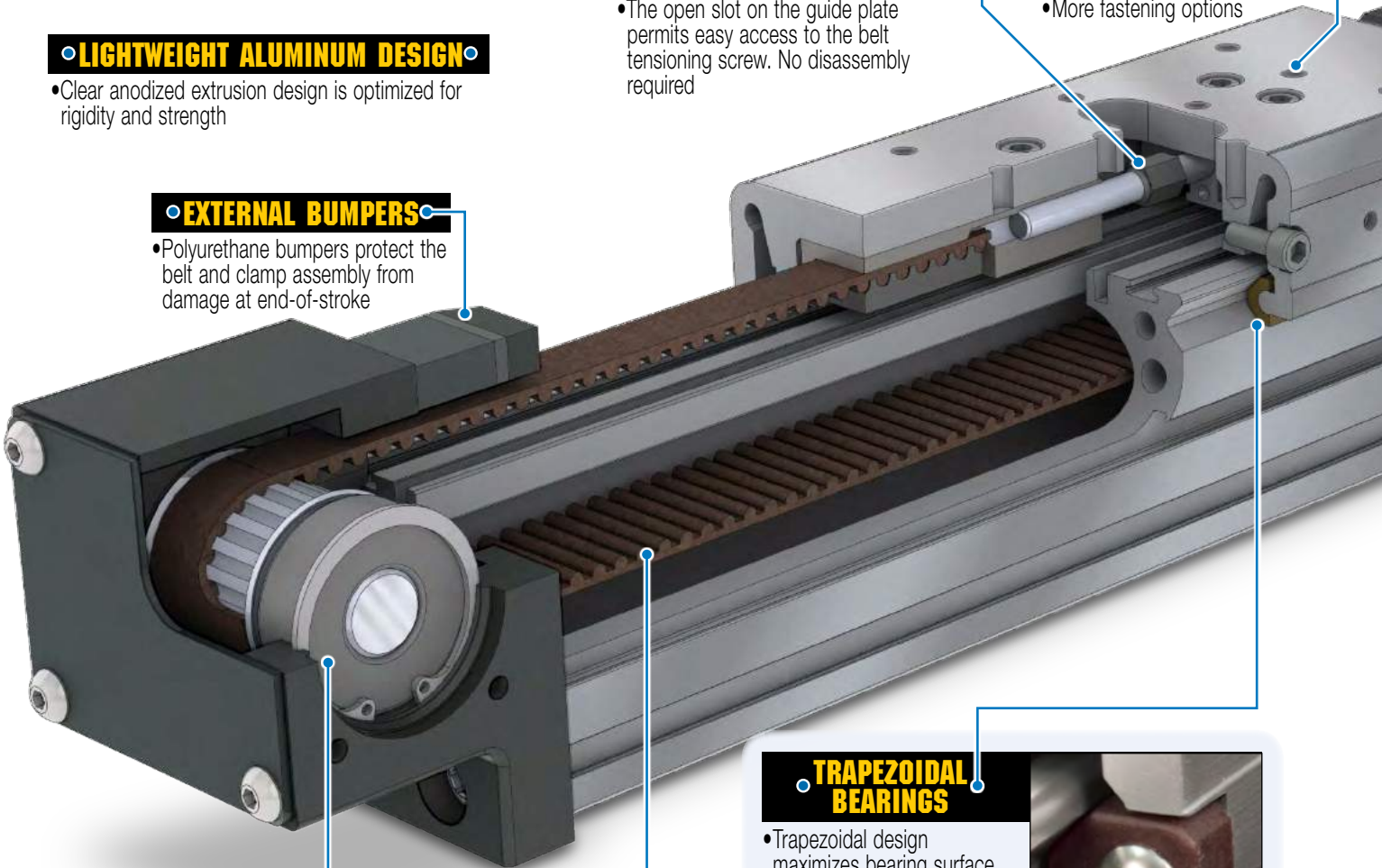

OVERSIZED PULLEY BEARINGS

- Drive shaft assembly incorporates oversized shielded/sealed ball bearings for long life and high speeds

DURABLE BELT MATERIAL

- High power polyurethane HTD tooth profile belt with steel tensile members resists stretching

TRAPEZOIDAL BEARINGS

- Trapezoidal design maximizes bearing surface area for less pressure on bearing surfaces; less pressure results in less wear
- Engineered bearing material has low static and dynamic friction with low wear properties for long lasting, smooth operation
- Bearings are field replaceable for extended service life

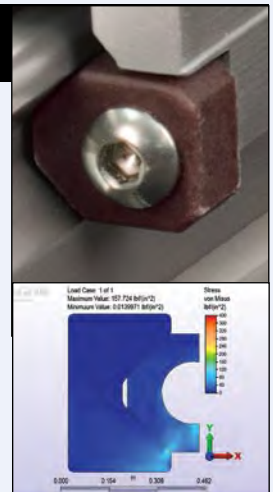

• INCH OR METRIC MOUNTING •

- Your choice of inch (US standard) or metric mounting to the carrier

• MOTOR ORIENTATION •

YOU CAN CHOOSE:

- Direct drive option directly couples motor to the drive shaft; one-piece housing construction for optimum alignment and support of the motor
- Reduction option in 3:1 reduction (2:1 on MXB16)

• YOUR MOTOR HERE •

YOU CAN CHOOSE:

- Motor or gearbox supplied and installed by Tolomatic
- Specify the device to be installed and actuator ships with proper mounting hardware - MXB is a "Your Motor Here" actuator for easy direct drive motor installation. Check our website (www.tolomatic.com/ymh) for complete information
- Specify and ship your device to Tolomatic for factory installation

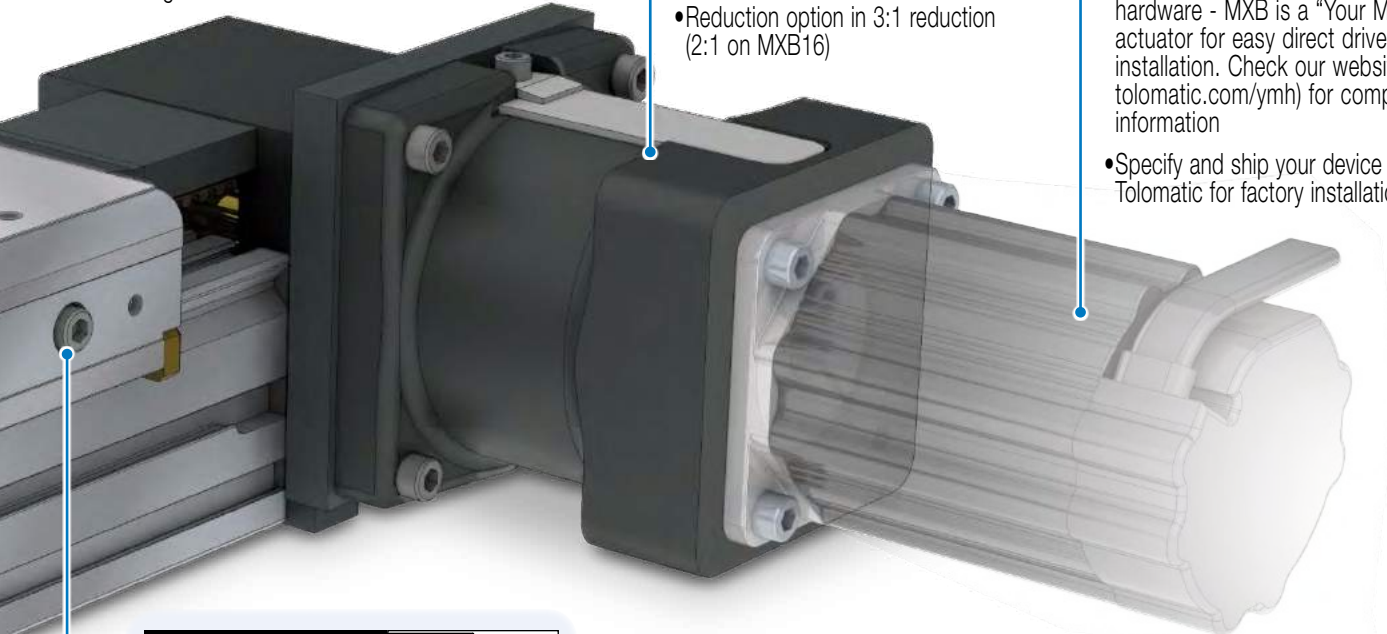

NON-BINDING BEARING ARMS

- Bearings are tensioned indirectly, providing bind free adjustment

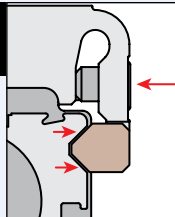

OPTIONS

NOTE: Boxed letters indicate ordering codes



AUXILIARY CARRIER DC

- 2X higher Fz (load) capacity
- High bending moment capacity



FLOATING MOUNT FL

- Compensates for non-parallelism between MX actuator and externally guided load



TUBE CLAMPS TC

- Used for intermediate support
- Flush with bottom of actuator to retain low profile
- Drop-in, adjustable mounting locations (MXB16 uses T-nuts with mounting plates)



MOUNTING PLATES MP

- Provides clearance for motor and mount
- 16,25,32 sizes attach with T-Nuts
- 40,50,63 sizes attach with Tube Clamps



HEAD COVER PLATE HC2

- Provides protection for pulley and bearing



SWITCHES

- Wide variety of sensing choices: Reed, Solid State PNP or NPN, available normally open or normally closed
- Flush mount, drop-in installation
- Bright LEDs, power & signal indication
- CE rated, RoHS compliant

MXB-P PROFILED RAIL BELT DRIVE ACTUATOR

ENDURANCE TECHNOLOGYSM

Endurance TechnologySM features are designed for maximum durability to provide extended service life.

The MXB-P rodless electric belt-drive actuator is designed for applications requiring moderate to heavy load carrying and guidance. The MXB-P actuator features a profiled rail system with recirculating ball linear guides for optimal performance. The MXB-P belt-driven actuator features speeds up to 150 in/sec and thrusts up to 418 lbf. Built-to-order in stroke lengths up to 200 inches.

• LOW CARRIER HEIGHT •

- Reduces overall actuator envelope
- Large mounting pattern for excellent load stability

• DURABLE BELT MATERIAL •

- High power polyurethane HTD tooth profile belt with steel tensile members resists stretching

• OVERSIZED PULLEY BEARINGS •

- Drive shaft assembly incorporates oversized shielded/sealed ball bearings for long life and high speeds

• MOTOR ORIENTATION •

YOU CAN CHOOSE:

- Direct drive option directly couples motor to the drive shaft; one-piece housing construction for optimum alignment and support of the motor
- Reduction option in 3:1 reduction (2:1 on MXB16)

• YOUR MOTOR HERE •

YOU CAN CHOOSE:

- Motor or gearbox supplied and installed by Tolomatic
- Specify the device to be installed and actuator ships with proper mounting hardware - MXB is a "Your Motor Here" actuator for easy direct drive motor installation. Check our website (www.tolomatic.com/ymh) for complete information
- Specify and ship your device to Tolomatic for factory installation

• INCH OR METRIC MOUNTING •

- Your choice of inch (US standard) or metric mounting to the carrier

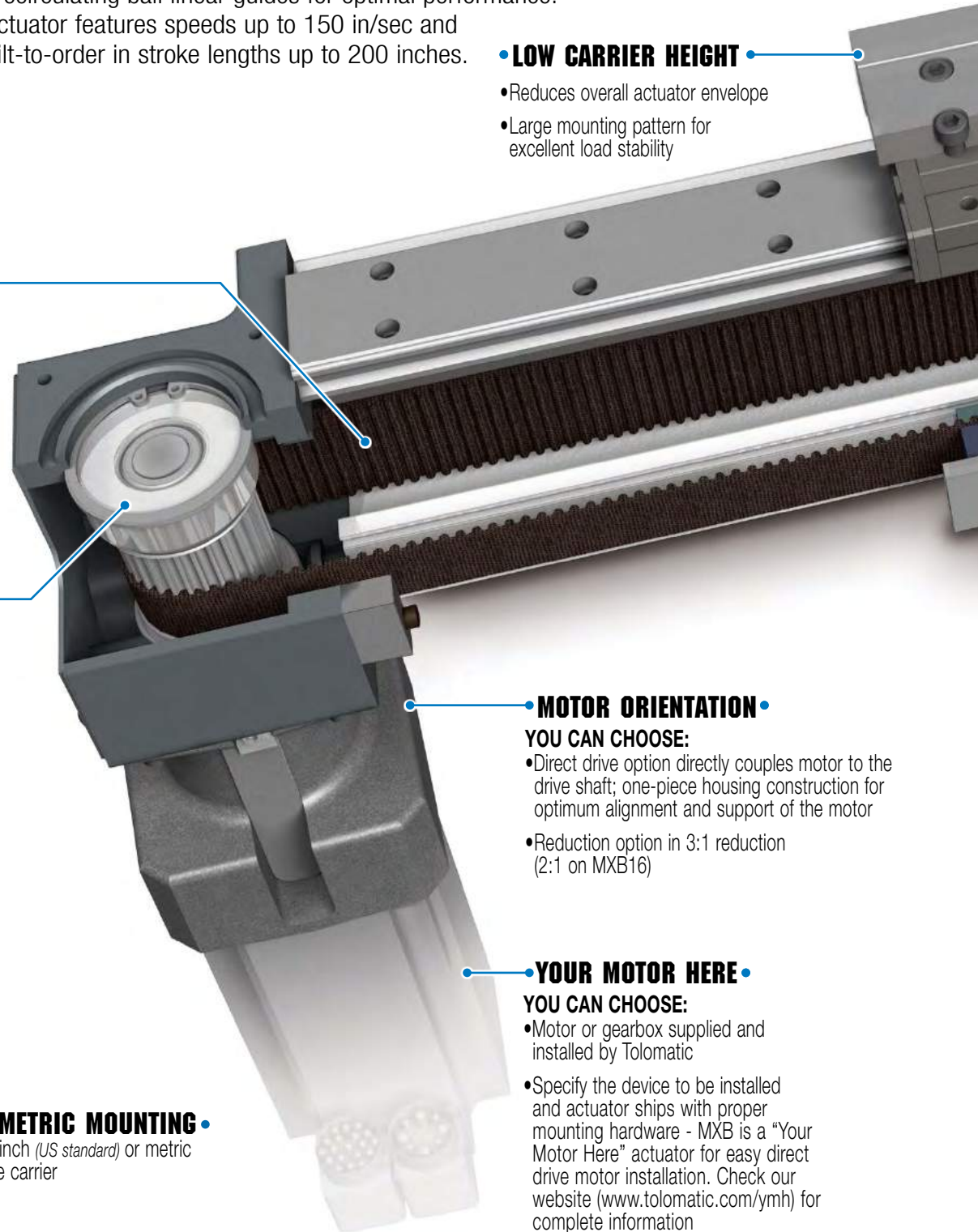

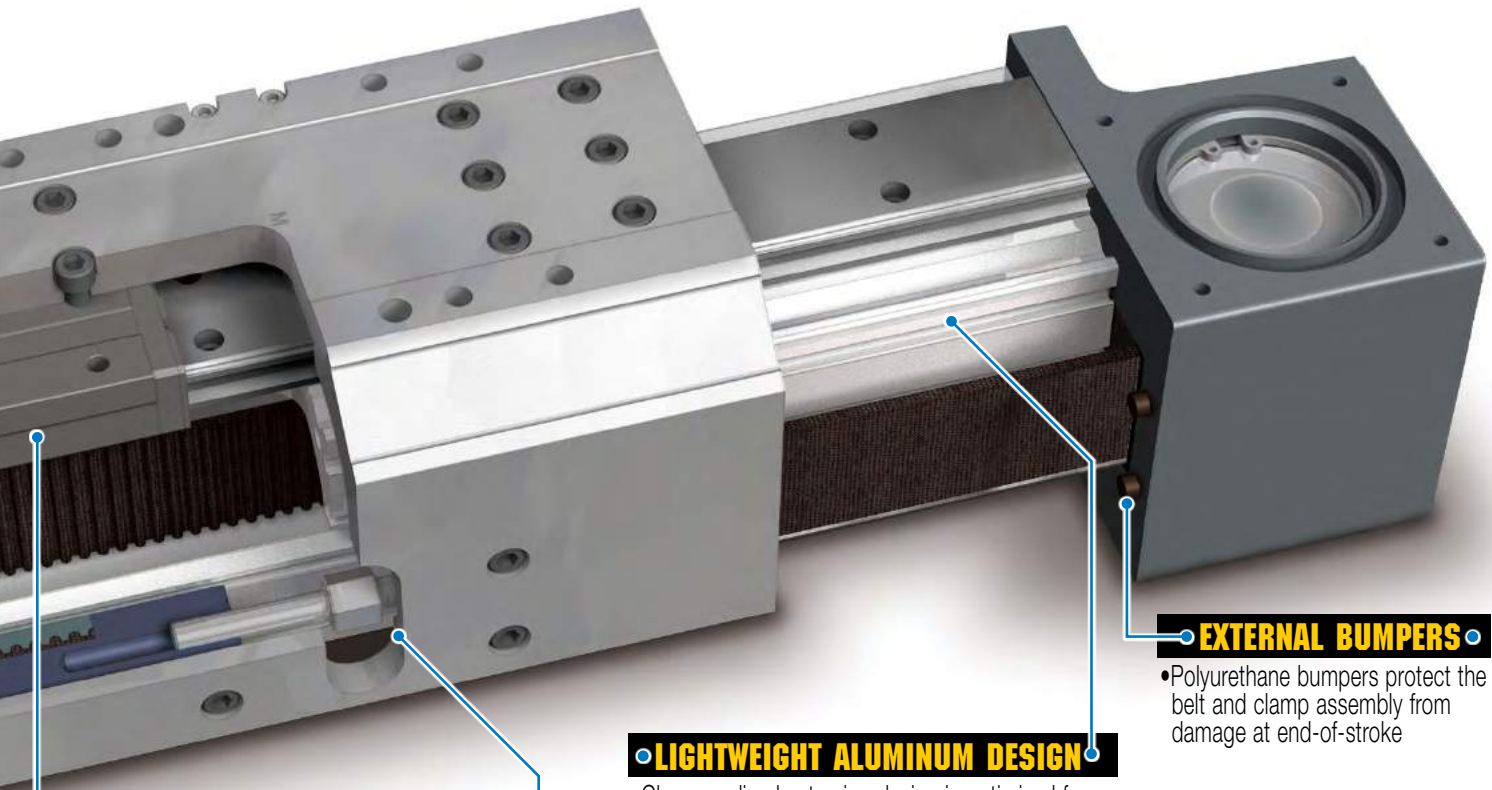

EXTERNAL BUMPERS

- Polyurethane bumpers protect the belt and clamp assembly from damage at end-of-stroke

LIGHTWEIGHT ALUMINUM DESIGN

- Clear anodized extrusion design is optimized for rigidity and strength

BELT TENSIONING SYSTEM

- The open slot on the carrier side permits easy access to the belt tensioning screw. No disassembly required and no need to remove the load from the carrier

RECIRCULATING BALL BEARINGS

- Recirculating ball bearings are used to reduce friction and extend actuator life
- Designed with a grease pocket between ball elements to reduce friction, noise and maintenance
- Large permissible moment loads
- High speed operation, low heat generation
- High precision, smooth, low friction motion

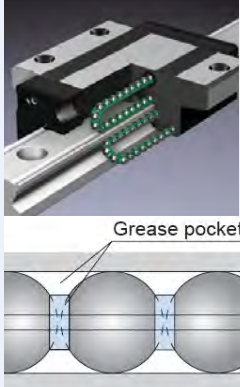

NOTE: Boxed letters indicate ordering codes

OPTIONS







AUXILIARY CARRIER DC

- 2X higher Fz & Fy (load) capacity
- High bending moment capacity

MOUNTING PLATES MP

- Provides clearance for motor and mount
- 16,25,32 sizes attach with T-Nuts
- 40,50,63 sizes attach with Tube Clamps

TUBE CLAMPS TC

- Used for intermediate support
- Flush with bottom of actuator to retain low profile
- Drop-in adjustable mounting locations
- (Not available on the 16, 25 or 32 MXB-P sizes)

HEAD COVER PLATE HC2

- Provides protection for pulley and bearing

SWITCHES

- Wide variety of sensing choices: Reed, Solid State PNP or NPN, available normally open or normally closed
- Flush mount, drop-in installation
- Bright LEDs, power & signal indication
- CE rated, RoHS compliant

MXB Rodless Belt Drive Actuators

ACTUATOR SPECIFICATIONS AND BREAKAWAY TORQUE

MXB U , S & P											BREAKAWAY TORQUE			
MXB SIZE	BELT WIDTH		BELT DEAD LENGTH		PULLEY PITCH DIAMETER		STROKE PER REVOLUTION		*MAXIMUM STROKE		SINGLE CARRIER		AUXILIARY CARRIER OPT. (MXB-P)	
	in	mm	in	mm	in	mm	in	mm	in	mm	lb-in	N-m	lb-in	N-m
16	0.39	10	14.29	363.0	0.753	19.1	2.366	60.1	230	5842	4.0	0.452	6.0	0.678
25	0.71	18	18.72	475.5	1.003	25.5	3.151	80.0	204	5181	5.0	0.565	7.0	0.791
32	0.98	25	21.89	556.0	1.253	31.8	3.936	100.0	203	5156	8.0	0.904	10.0	1.130
40	1.18	30	24.95	633.7	1.504	38.2	4.725	120.0	202	5130	10.0	1.130	12.0	1.356
50	1.57	40	27.25	692.2	1.754	44.6	5.510	140.0	202	5130	15.0	1.695	18.0	2.034
63	1.97	50	36.11	917.2	2.130	54.1	6.692	170.0	102	2590	20.0	2.260	25.0	2.825

*Longer lengths may be possible with use of tube couplers - Contact Tolomatic

MXB-U SIZE	WEIGHT								INERTIA							
	PLATE ASSEMBLY		BELT TENSIONER ASSEMBLY		BASE ACTUATOR		PER UNIT OF STROKE		DRIVE/IDLE PULLEY ASSEMBLIES		PLATE ASSEMBLY (INCLUDING BELT TENSIONER ASSEMBLY)		PER UNIT OF STROKE			
	lb	kg	lb	kg	lb	kg	lb/in	kg/cm	lb-in ²	kg-cm ²	lb-in ²	kg-cm ²	lb-in ²	kg-cm ²		
16	0.11	0.05	0.10	0.05	1.59	0.72	0.084	0.0150	0.0085	0.0250	0.0335	0.0980	0.0005	0.0006		
25	0.27	0.12	0.15	0.07	2.59	1.17	0.138	0.0246	0.0259	0.0759	0.1201	0.3515	0.0017	0.0020		
32	0.48	0.22	0.30	0.13	4.17	1.89	0.237	0.0423	0.1416	0.4143	0.3451	1.0099	0.0037	0.0043		
40	0.90	0.41	0.46	0.21	7.83	3.55	0.352	0.0629	0.3719	1.0884	0.8487	2.4836	0.0065	0.0075		
50	1.03	0.47	0.72	0.33	9.93	4.50	0.472	0.0843	0.7243	2.1196	1.5103	4.4198	0.0117	0.0135		
63	2.54	1.15	0.83	0.38	16.44	7.46	0.833	0.1488	1.9512	5.7101	4.2168	12.3401	0.0216	0.0249		

MXB-P SIZE	WEIGHT								INERTIA							
	CARRIER ASSEMBLY		BELT TENSIONER ASSEMBLY		BASE ACTUATOR		PER UNIT OF STROKE		DRIVE/IDLE PULLEY ASSEMBLIES		CARRIER ASSEMBLY (INCLUDING BELT TENSIONER ASSEMBLY)		PER UNIT OF STROKE			
	lb	kg	lb	kg	lb	kg	lb/in	kg/cm	lb-in ²	kg-cm ²	lb-in ²	kg-cm ²	lb-in ²	kg-cm ²		
16	0.33	0.15	0.10	0.05	1.86	0.84	0.102	0.0183	0.0085	0.0250	0.131	0.383	0.255	0.746	0.0005	0.0006
25	0.54	0.24	0.15	0.07	3.64	1.65	0.195	0.0348	0.0259	0.0759	0.375	1.097	0.739	2.163	0.0017	0.0020
32	1.00	0.45	0.30	0.14	5.80	2.63	0.318	0.0569	0.1416	0.4143	1.113	3.257	2.198	6.432	0.0037	0.0043
40	1.77	0.80	0.46	0.21	11.16	5.06	0.537	0.0959	0.3719	1.0884	2.872	8.405	5.644	16.517	0.0065	0.0075
50	2.57	1.17	0.72	0.33	16.20	7.35	0.749	0.1337	0.7243	2.1196	6.220	18.202	12.216	35.749	0.0117	0.0135
63	7.54	3.42	0.83	0.38	32.10	14.56	1.110	0.1981	1.9512	5.7101	31.285	91.552	62.259	182.195	0.0216	0.0249

MXB-P SIZE	WEIGHT								INERTIA							
	CARRIER ASSEMBLY		BELT TENSIONER ASSEMBLY		BASE ACTUATOR		PER UNIT OF STROKE		DRIVE/IDLE PULLEY ASSEMBLIES		CARRIER ASSEMBLY (INCLUDING BELT TENSIONER ASSEMBLY)		PER UNIT OF STROKE			
	lb	kg	lb	kg	lb	kg	lb/in	kg/cm	lb-in ²	kg-cm ²	lb-in ²	kg-cm ²	lb-in ²	kg-cm ²		
16	0.39	0.18	0.10	0.05	2.38	1.08	0.102	0.0183	0.0085	0.0250	0.4856	1.4211	0.8716	2.5506	0.0005	0.0006
25	0.84	0.38	0.15	0.07	4.36	1.98	0.195	0.0348	0.0259	0.0759	0.9914	2.9013	1.8353	5.3708	0.0017	0.0020
32	1.64	0.74	0.30	0.13	7.83	3.55	0.318	0.0569	0.1416	0.4143	1.9356	5.6642	3.5757	10.4641	0.0037	0.0043
40	2.51	1.14	0.46	0.21	14.07	6.38	0.537	0.0959	0.3719	1.0884	2.9693	8.6893	5.4832	16.0460	0.0065	0.0075
50	5.03	2.28	0.72	0.33	20.84	9.45	0.749	0.1337	0.7243	2.1196	5.7498	16.8263	10.7770	31.5378	0.0117	0.0135
63	9.36	4.25	0.83	0.38	37.24	16.89	1.110	0.1981	1.9512	5.7101	10.1930	29.8288	19.5537	57.2221	0.0216	0.0249

MAXIMUM VELOCITY **U** 200 in/sec 5080 mm/sec

MAXIMUM VELOCITY **S** 100 in/sec 2540 mm/sec

MAXIMUM VELOCITY **P** 150 in/sec 3810 mm/sec

MAXIMUM ACCELERATION 1200 in/sec² 30.48 m/sec²

REPEATABILITY ± 0.002 in ± 0.051 mm

TEMPERATURE RANGE 10 to 130 °F -12 to 54 °C

⚠ Heat generated by the motor and drive should be taken into consideration as well as linear velocity and work cycle time. For applications that require operation outside of the recommended temperature range, contact the factory.

STRAIGHTNESS, FLATNESS 0.00067 L in 0.01702 L mm
Actuator mounted on a flat surface and fully restrained (see Mounting Plate Requirements, page mx_b_11) L = Maximum distance between supports

⚠ The listed values relating to straightness/flatness are intended for reference purposes only, and not as an engineering standard of absolute tolerance for a given actuator. Appropriate installation is the single most important factor in reducing variation, so good engineering practices such as measurement, mapping, etc. must be employed in applications with stringent straightness/flatness requirements.

MXB Rodless Belt Drive Actuators

sizeit.tolomatic.com for fast, accurate actuator selection

S & P TUBE CLAMP REQUIREMENTS

S SOLID BEARING

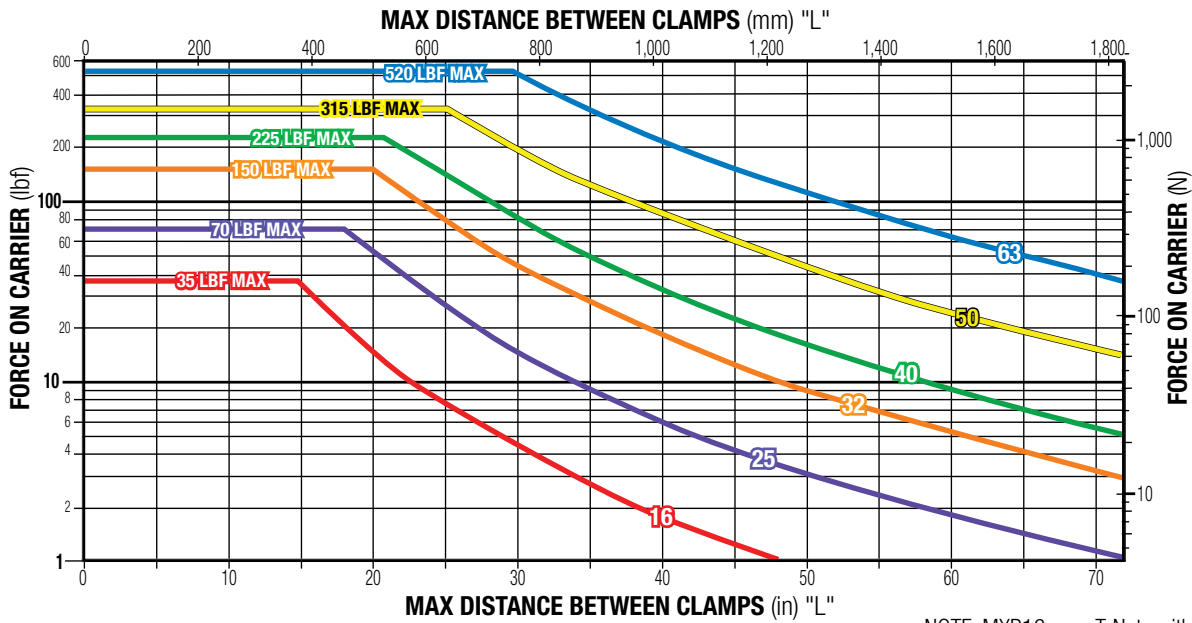

NOTE: MXB16 uses T-Nuts with mounting plates

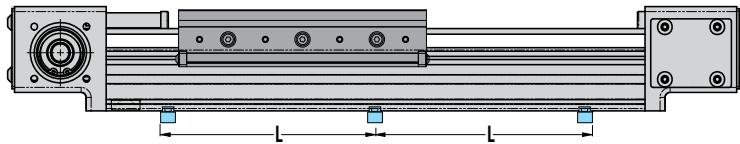

P PROFILE RAIL BEARING

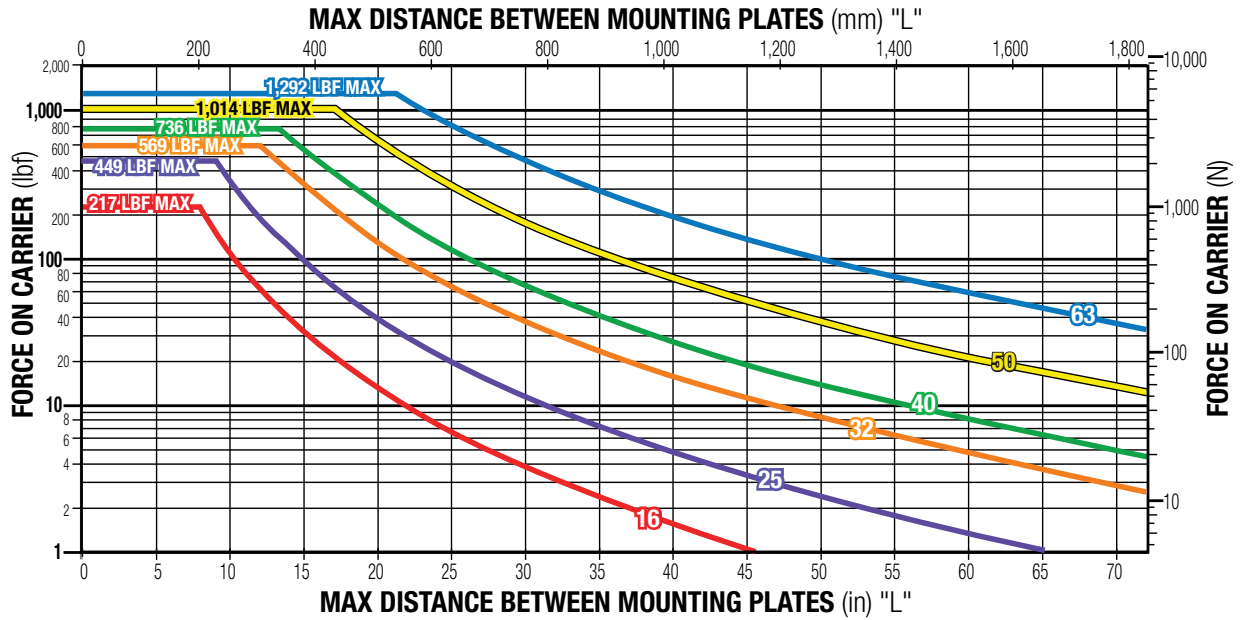

NOTE: MXB16 uses T-Nuts with mounting plates

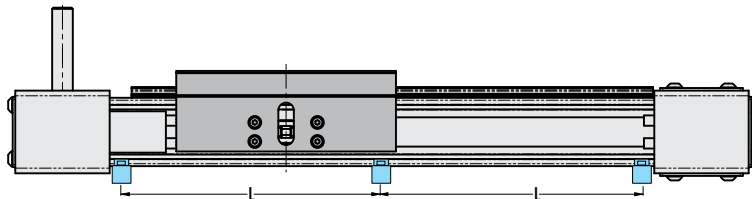

MXB-S Rodless Belt Drive Actuators

S SOLID BEARING MOMENT AND LOAD CAPACITY

STANDARD CARRIER

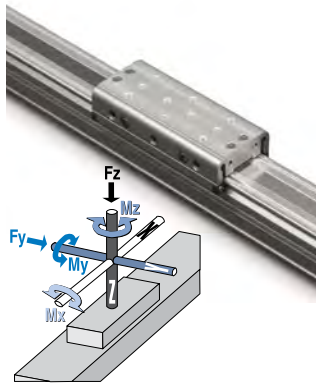

SIZE	MAXIMUM BENDING MOMENTS						MAX. LOAD	
	Mx		My		Mz		Fz	
	in-lbs	N-m	in-lbs	N-m	in-lbs	N-m	lbf	N
16	22	2.5	19	2.1	25	2.8	35	156
25	60	6.8	110	12.4	34	3.8	70	311
32	100	11.3	350	39.5	140	15.8	150	667
40	275	31.1	600	67.8	220	24.9	225	1,001
50	315	35.6	1,155	131	341	38.5	315	1,401
63	585	66.1	2,340	264	520	58.8	520	2,313

D/AUXILIARY CARRIER

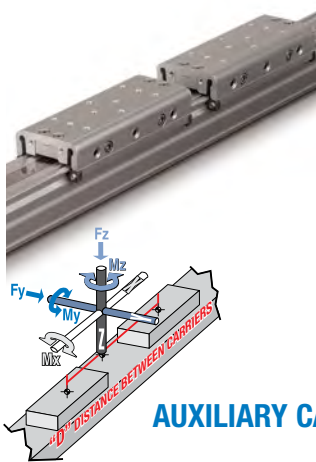

SIZE	"D" MINIMUM		MAXIMUM BENDING MOMENTS*						MAX. LOAD	
	in	mm	Mxa		Mya		Mza		Fza	
			in-lbs	N-m	in-lbs	N-m	in-lbs	N-m	lbf	N
16	5.0	127	44	5.0	175	19.8	175	19.8	70	311
25	6.0	152	120	13.6	420	47.5	420	47.5	140	623
32	7.0	178	200	22.6	1,050	119	1,050	119	300	1,334
40	8.5	216	550	62.1	1,913	216	1,913	216	450	2,002
50	8.6	218	630	71.2	2,709	306	2,709	306	630	2,802
63	13.0	330	1,170	132	6,760	764	6,760	764	1,040	4,626

*At minimum "D" distance see graph below for complete information

AUXILIARY CARRIER BENDING MOMENTS WITH INCREASED "D" DISTANCE BETWEEN CARRIERS

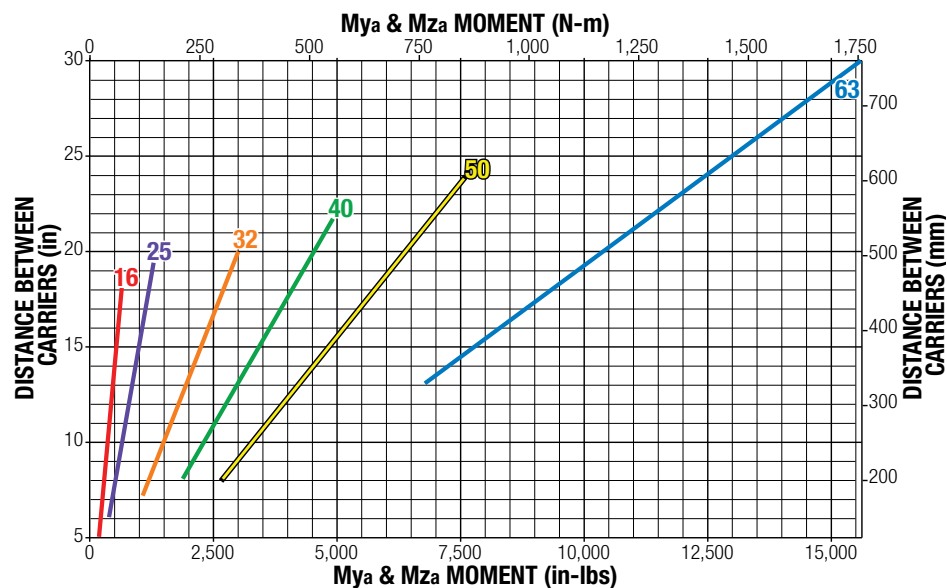

Ratings were calculated with the following conditions:

- 1.) Coupling between carriers is rigid.
- 2.) Load is equally distributed between carriers.
- 3.) Coupling device applies no misalignment loads to carriers.

⚠ The above ratings are the maximum values for shock-free, vibration-free operation in a typical industrial environment, which must not be exceeded even in dynamic operation. Contact Tolomatic for assistance in selecting the most appropriate actuator for your application.

The moment and load capacity of the actuator bearing system is based on an L10 life of 200,000,000 linear inches of travel. Life of the actuator will vary for each application depending on the combined loads, motion parameters and operating conditions. The load factor (L_f) for each application must not exceed a value of 1, as calculated below. Exceeding a load factor of 1 will diminish the actuator rated life.

$$L_f = \frac{M_x}{M_{x_{max}}} + \frac{M_y}{M_{y_{max}}} + \frac{M_z}{M_{z_{max}}} + \frac{F_y}{F_{y_{max}}} + \frac{F_z}{F_{z_{max}}} \leq 1$$

With combined loads, L_f must not exceed the value 1.

MXB-P Rodless Belt Drive Actuators

PROFILED RAIL BEARING MOMENT AND LOAD CAPACITY

⚠ Mating surface of mounted component must maintain a flatness of at least .0015" [0.040 mm]

STANDARD CARRIER

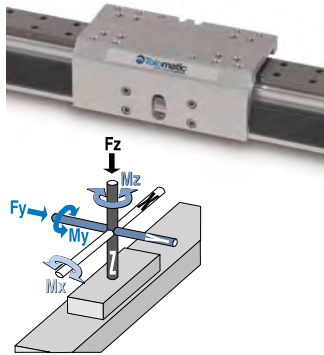

SIZE	MAXIMUM BENDING MOMENTS						MAXIMUM LOAD				MAXIMUM THRUST	
	Mx		My		Mz		Fy		Fz			
	in-lbs	N-m	in-lbs	N-m	in-lbs	N-m	lbf	N	lbf	N	lbf	N
16	39	4.5	339	38.3	339	38.3	217	966	217	966	38	169
25	126	14.3	502	56.7	377	42.6	449	1,996	449	1,996	151	672
32	226	25.6	1,344	152	1,344	152	569	2,531	569	2,531	209	930
40	604	68.2	1,913	216	1,913	216	736	3,274	736	3,274	250	1,112
50	811	91.7	3,483	394	3,483	394	1,014	4,510	1,014	4,510	325	1,446
63	1,019	115	5,339	603	5,339	603	1,292	5,745	1,292	5,745	418	1,859

AUXILIARY CARRIER

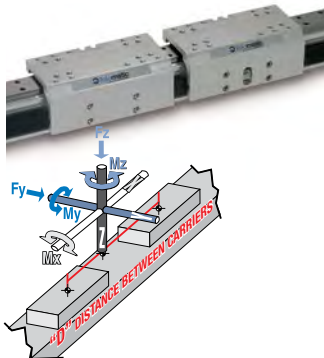

SIZE	"D" MINIMUM		MAXIMUM BENDING MOMENTS*						MAXIMUM LOAD			
	in	mm	Mxa		Mya		Mza		Fya		Fza	
			in-lbs	N-m	in-lbs	N-m	in-lbs	N-m	lbf	N	lbf	N
16	5.0	127	79	8.9	620	70.0	620	70.0	434	1,932	434	1,932
25	6.0	152	252	28.5	1,610	182	1,610	182	898	3,993	898	3,993
32	7.0	178	453	51.1	2,202	249	2,202	249	1,138	5,063	1,138	5,063
40	8.5	216	1,208	136	3,601	407	3,601	407	1,472	6,549	1,472	6,549
50	8.6	218	1,623	183	4,966	561	4,966	561	2,028	9,020	2,028	9,020
63	13.0	330	2,038	230	9,508	1,074	9,508	1,074	2,583	11,490	2,583	11,490

*At minimum "D" distance - see graph below for bending moments at greater distances

AUXILIARY CARRIER BENDING MOMENTS WITH INCREASED "D" DISTANCE BETWEEN CARRIERS

Ratings were calculated with the following conditions:

- 1.) Coupling between carriers is rigid.
- 2.) Load is equally distributed between carriers.
- 3.) Coupling device applies no misalignment loads to carriers.

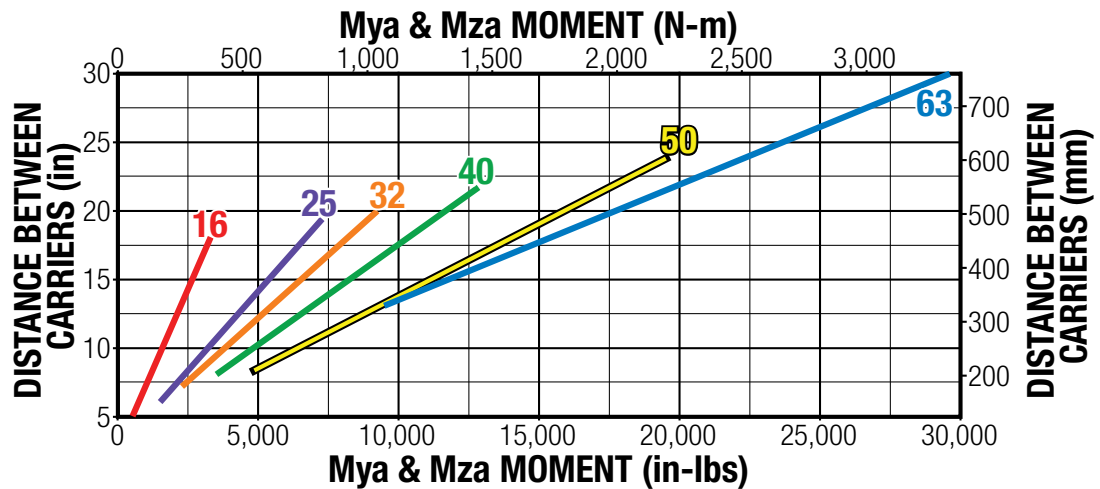

⚠ The above ratings are the maximum values for shock-free, vibration-free operation in a typical industrial environment, which must not be exceeded even in dynamic operation. Contact Tolomatic for assistance in selecting the most appropriate actuator for your application.

The moment and load capacity of the actuator bearing system is based on an L10 life of 200,000,000 linear inches of travel. Life of the actuator will vary for each application depending on the combined loads, motion parameters and operating conditions. The load factor (L_f) for each application must not exceed a value of 1, as calculated below. Exceeding a load factor of 1 will diminish the actuator rated life.

$$L_f = \frac{M_x}{M_{x_{max}}} + \frac{M_y}{M_{y_{max}}} + \frac{M_z}{M_{z_{max}}} + \frac{F_y}{F_{y_{max}}} + \frac{F_z}{F_{z_{max}}} \leq 1$$

With combined loads, L_f must not exceed the value 1.

MXB-P Rodless Belt Drive Actuator

sizeit.tolomatic.com for fast, accurate actuator selection

LOAD DEFLECTION

DEFLECTION TESTING WAS DONE UNDER THESE CRITERIA:

- 1.) Actuator was properly mounted with distance between mounting plates within recommendations (see Mounting Plate Requirements page me_11)
- 2.) Deflection was measured at 12" from center of carrier as shown

DEFLECTION ABOUT X AXIS

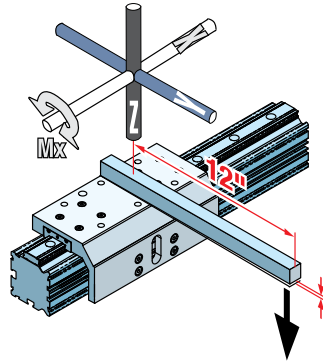
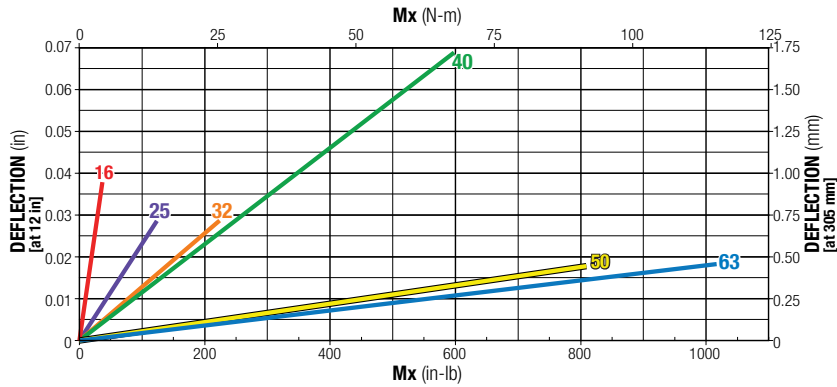

DEFLECTION ABOUT Y AXIS

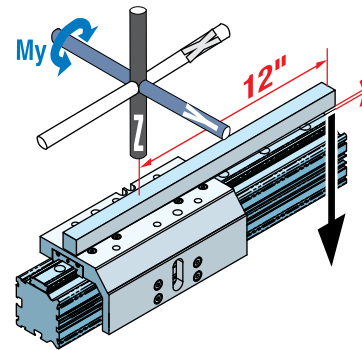
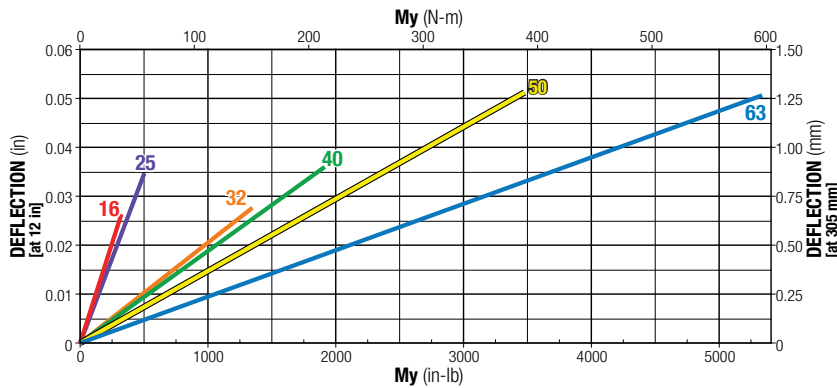

DEFLECTION ABOUT Z AXIS

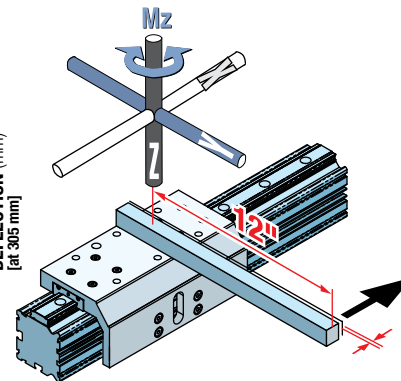
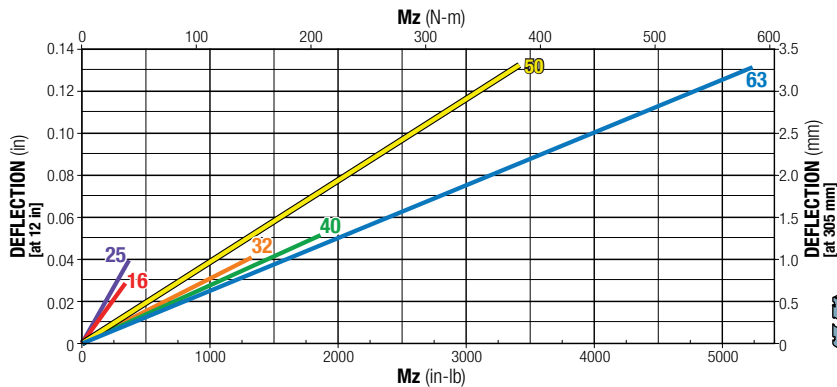

SPEED FACTOR

FOR APPLICATIONS WITH HIGH SPEED OR SIGNIFICANT SHOCK AND VIBRATION: Calculated values of loads and bending moments must be increased by speed factor from the graph at right to obtain full rated life of profiled rail bearing system.

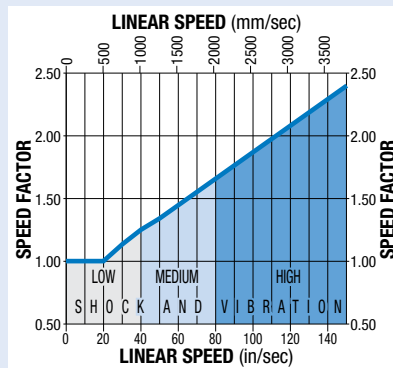

PROFILLED RAIL LUBRICATION

Proper lubrication of profiled rail bearing system is essential for normal operation and achievement of full rated life of MX-P actuators. Lubrication should be performed at intervals of 4,000,000 inches of travel or once every year, whichever occurs first. **However, operating conditions such as high speed or significant shock and vibration may require more frequent lubrication.** Please consult Tolomatic for recommendations.

Recommended grease types:

1. Refined mineral oil-based multi-purpose grease with lithium thickening agent.
2. High-grade synthetic oil-based grease with urea thickening agent.

MXB-U Rodless Belt Drive Actuator

3D CAD available at www.tolomatic.com Toll Free Phone (877) SERV098
 Always use configured CAD solid model to determine critical dimensions. www.tolomatic.com

ACTUATOR & OPTION DIMENSIONS

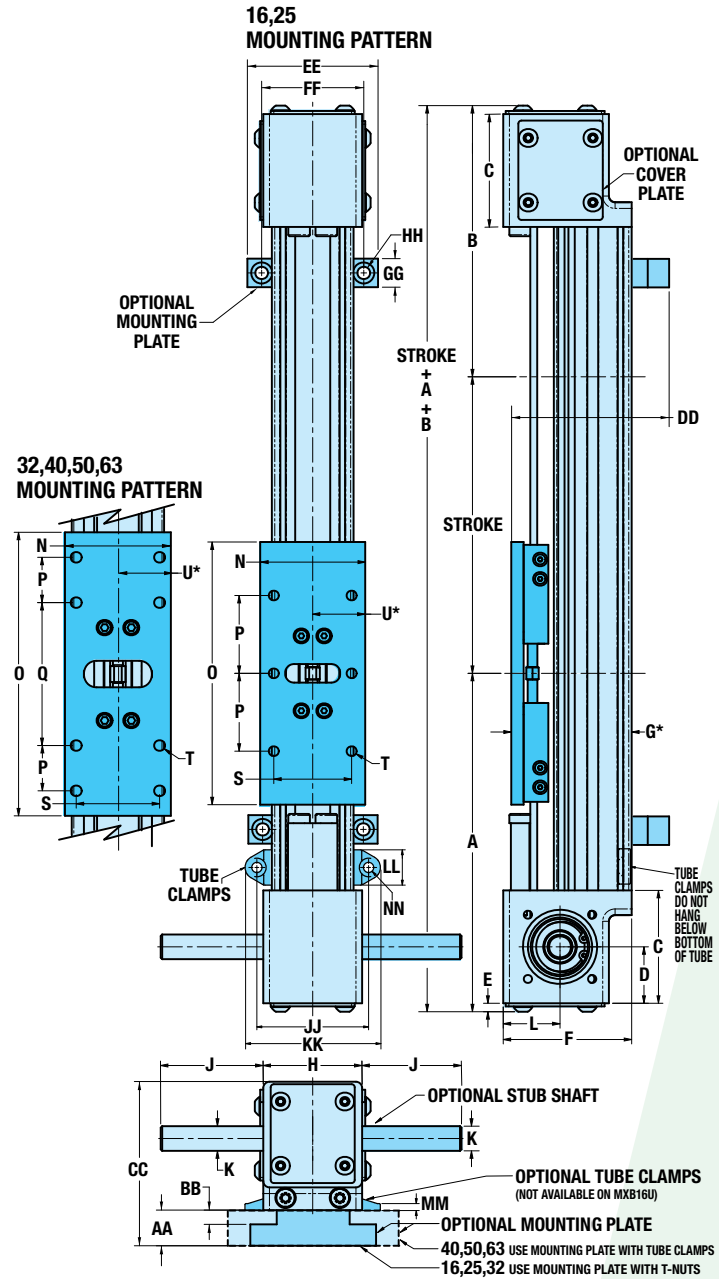

	MXB16	MXB25	MXB32	MXB40	MXB50	MXB63
A	5.33	6.85	7.39	8.53	8.85	10.83
mm	135.3	173.9	187.8	216.6	224.7	275.1
B	4.69	5.49	6.09	7.59	8.07	10.33
mm	119.0	139.3	154.7	192.7	205.0	262.1
C	2.00	2.28	2.20	3.10	3.25	3.79
mm	50.8	58.0	55.9	78.7	82.6	96.1
D	1.00	1.14	1.00	1.55	1.58	1.79
mm	25.4	29.0	25.4	39.4	40.0	45.3
E	0.15	0.17	0.17	0.17	0.17	0.17
mm	3.8	4.4	4.4	4.4	4.4	4.4
F	2.08	2.60	3.05	3.69	4.35	5.48
mm	52.8	66.0	77.5	93.8	110.6	139.3
G*	1.77	2.44	3.05	3.48	4.31	5.34
mm	45.3	61.9	77.4	88.3	109.6	135.5
H	1.75	2.00	2.75	3.25	3.88	4.38
mm	44.5	50.8	69.9	82.6	98.4	111.1
J	**	2.27	2.27	1.87	1.87	1.87
mm	**	57.7	57.7	47.5	47.5	47.5
K	0.375	0.500	0.500	0.500	0.500	0.500
mm	09.53	012.70	012.70	012.70	012.70	012.70
L	1.04	1.15	1.10	1.56	1.63	2.06
mm	26.4	29.2	27.9	39.7	41.5	52.2
N	1.38	2.13	2.50	3.50	3.75	4.50
mm	34.9	54.0	63.5	88.9	95.3	114.3
O	4.33	5.31	6.69	7.87	8.50	12.00
mm	110.0	135.0	170.0	200.0	216.0	304.8
P	1.57	1.57	1.07	1.00	1.00	1.57
mm	40.0	40.0	27.1	25.4	25.4	40.0
Q	-	-	3.37	4.50	2.75	5.12
mm	-	-	87.7	114.3	69.8	130.0
S	1.10	1.57	1.97	2.83	3.13	3.87
mm	28.0	40.0	50.0	72.0	79.4	98.3
T	#8-32(6)	1/4-20(6)	5/16-18(8)	5/16-18(8)	5/16-18(8)	3/8-16(8)
mm	M4x0.7	M6x1.0	M8x1.25	M8x1.25	M8x1.25	M10x1.5
U*	0.69	1.07	1.25	1.75	1.88	2.25
mm	17.5	27.0	31.8	44.5	47.7	57.2

OPTIONAL MOUNTING PLATES						
AA	0.63	0.63	0.75	1.00	1.25	1.00
mm	15.9	15.9	19.1	25.4	31.8	25.4
BB	0.25	0.25	0.30	-	-	-
mm	6.4	6.4	7.6	-	-	-
CC	2.71	3.22	3.80	4.70	5.60	6.48
mm	68.7	81.9	96.5	119.4	119.4	164.6
DD	2.4	3.06	3.75	4.18	5.01	6.04
mm	60.9	77.7	95.2	106.1	127.4	153.3
EE	2.36	2.50	3.40	5.00	5.60	8.00
mm	60.0	63.5	86.4	127.0	142.2	203.2
FF	1.75	2.00	2.75	4.41	5.00	7.00
mm	44.5	50.8	59.9	112.0	127.0	177.8
GG	1.00	1.00	1.00	0.79	0.79	1.00
mm	25.4	25.4	25.4	20.1	20.1	25.4
HH	0.22 THRU └┘ 0.37 └┘ 22 (2)	0.22 THRU └┘ 0.37 └┘ 22 (2)	0.28 THRU └┘ 0.44 └┘ 28 (2)	0.28 THRU (2)	0.28 THRU (2)	0.28 THRU (2)
mm	05.6 THRU └┘ 09.4 └┘ 5.6 (2)	05.6 THRU └┘ 09.4 └┘ 5.6 (2)	07.1 THRU └┘ 011.2 └┘ 7.1 (2)	07.1 THRU (2)	07.1 THRU (2)	07.1 THRU (2)

▲ *In order for the actuator to operate properly, dimensions "G" and "U" must not vary more than ±0.020 in [0.51mm] over the entire length of the stroke.

** MXB16
(LMI) J 0.59
mm 15.0
(RP) J 1.83
mm 46.6

OPTIONAL TUBE CLAMPS

	MXB16	MXB25	MXB32	MXB40	MXB50	MXB63
JJ	-	2.24	2.92	3.26	3.84	5.19
mm	-	57.0	74.1	82.7	97.5	131.7
KK	-	2.72	3.44	3.81	4.39	5.93
mm	-	69.0	87.4	96.7	111.5	150.7
LL	-	0.71	0.63	0.55	0.55	0.75
mm	-	18.0	16.0	14.0	14.0	19.0
MM	-	0.14	0.17	0.15	0.15	0.24
mm	-	3.6	4.3	3.8	3.8	6.1
NN	-	0.20	0.28	0.28	0.28	0.42
mm	-	5.2	7.1	7.1	7.1	10.7

MXB-S Rodless Belt Drive Actuator

SOLID BEARING DIMENSIONS

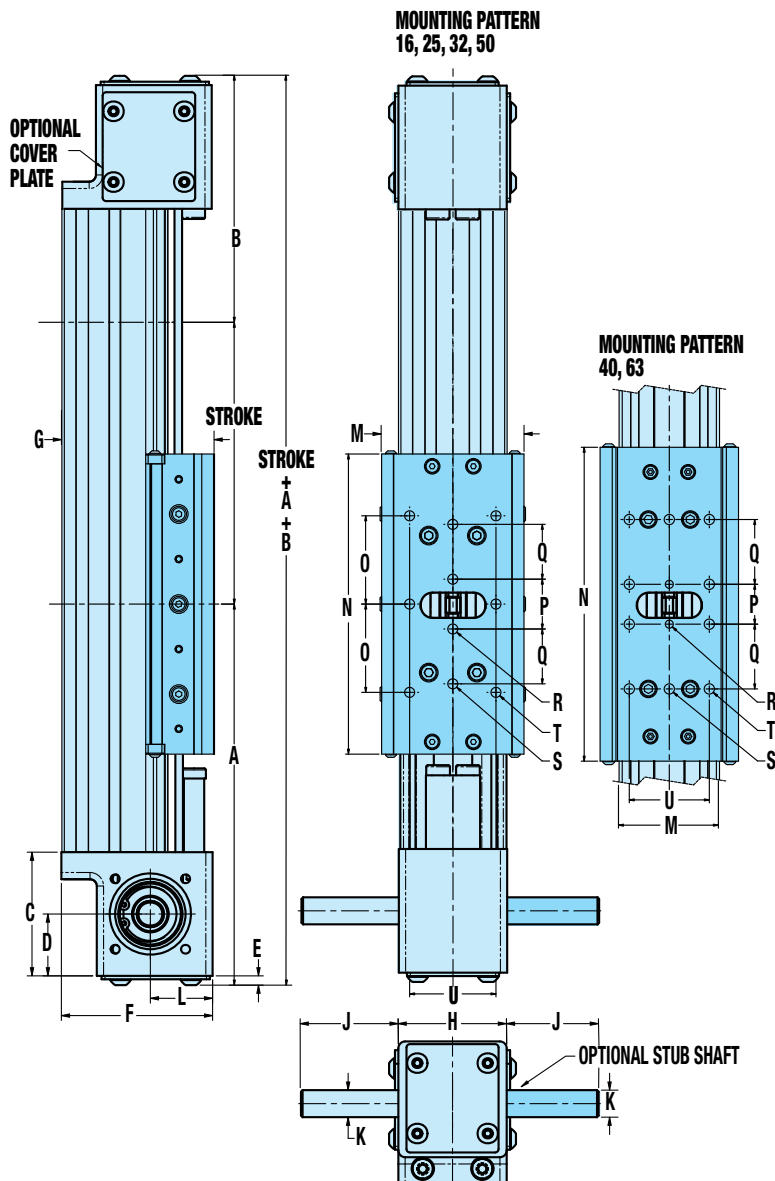

	MXB16	MXB25	MXB32	MXB40	MXB50	MXB63
A	5.33	6.85	7.06	8.53	8.57	10.83
mm	135.3	173.9	179.3	216.6	217.8	275.1
B	4.69	5.49	6.43	7.59	8.34	10.33
mm	119.0	139.3	163.2	192.7	212.0	262.1
C	2.00	2.28	2.20	3.10	3.25	3.79
mm	50.8	58.0	55.9	78.7	82.6	96.1
D	1.00	1.14	1.00	1.55	1.58	1.79
mm	25.4	29.0	25.4	39.4	40.0	45.3
E	0.15	0.17	0.17	0.17	0.17	0.17
mm	3.8	4.4	4.4	4.4	4.4	4.4
F	2.08	2.60	3.05	3.69	4.35	5.48
mm	52.8	66.0	77.5	93.8	110.6	139.3
G*	1.80	2.30	3.06	3.51	4.44	5.50
mm	45.8	58.4	77.8	89.2	112.8	139.7
H	1.75	2.00	2.75	3.25	3.88	4.38
mm	44.5	50.8	69.9	82.6	98.4	111.1
(LMI) J	0.59	2.27	2.27	1.87	1.87	1.87
mm	15.0	57.7	57.7	47.5	47.5	47.5
(RP) J	1.83	2.27	2.27	1.87	1.87	1.87
mm	46.6	57.7	57.7	47.5	47.5	47.5
K	Ø.375	Ø.500	Ø.500	Ø.500	Ø.500	Ø.500
mm	Ø9.53	Ø12.70	Ø12.70	Ø12.70	Ø12.70	Ø12.70
L	1.04	1.15	1.10	1.56	1.63	2.06
mm	26.4	29.2	27.9	39.7	41.5	52.2
M	1.58	2.18	2.86	3.47	4.1	5.59
mm	40.1	55.4	72.6	88.2	104.1	142
N	4.33	5.31	6.02	7.87	7.91	12.11
mm	110.0	134.9	153	200	200.9	307.6
O	1.18	1.57	1.77	-	1.88	-
mm	30	39.9	45	-	47.8	-
P	-	1.00	1.00	1.00	2.50	3.00
mm	-	25.4	25.4	25.4	63.5	76.2
Q	-	1.07	1.10	1.63	1.25	1.50
mm	-	27.2	28	41.3	31.8	38.1
R	-	1/4-20 (2)	1/4-20 (2)	1/4-20 (2)	3/8-16 (2)	3/8-16 (2)
mm	-	M6x1.0 (2)	M8x1.25 (2)	M8x1.25 (2)	M10x1.5 (2)	M10x1.5 (2)
S	-	#10-32 (2)	1/4-20 (2)	5/16-18 (2)	3/8-16 (2)	3/8-16 (2)
mm	-	M6x1.0 (2)	M8x1.25 (2)	M8x1.25 (2)	M10x1.5 (2)	M10x1.5 (2)
T	#8-32 (6)	1/4-20 (6)	1/4-20 (6)	5/16-18 (8)	3/8-16 (6)	3/8-16 (8)
mm	M4x0.7 (6)	M6x1.0 (6)	M8x1.25 (6)	M8x1.25 (8)	M10x1.5 (6)	M10x1.5 (8)
U*	1.18	1.18	1.73	2.00	2.59	3.25
mm	30.0	30.0	44.0	51.0	65.8	82.6

MXB-S Rodless Belt Drive Actuator

3D CAD available at www.tolomatic.com Toll Free Phone (877) SERV098
 Always use configured CAD solid model www.tolomatic.com to determine critical dimensions. (877) SERV099

SOLID BEARING OPTION DIMENSIONS

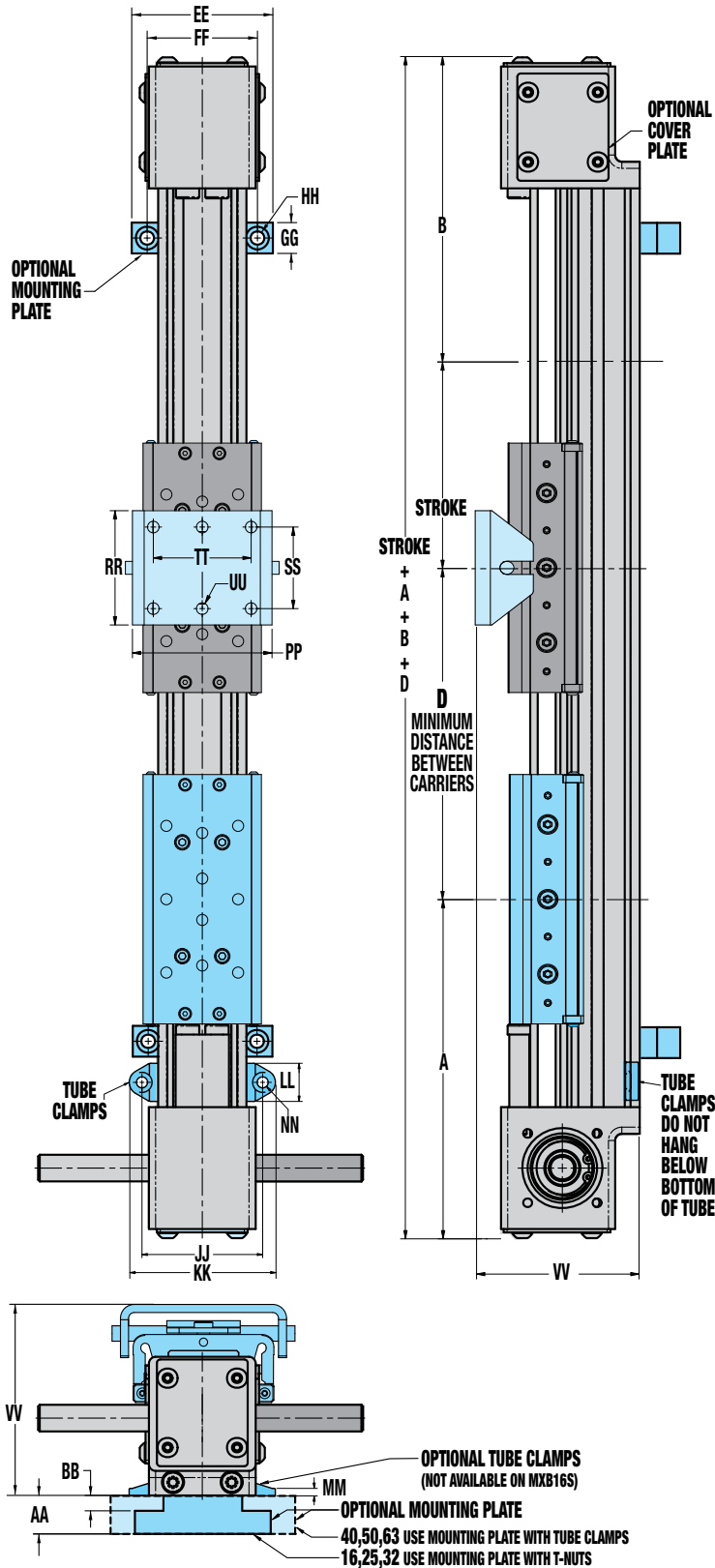

	MXB16	MXB25	MXB32	MXB40	MXB50	MXB63
A	5.33	6.85	7.06	8.53	8.57	10.83
mm	135.3	173.9	179.3	216.6	217.8	275.1
B	4.69	5.49	6.43	7.59	8.34	10.33
mm	119.0	139.3	163.2	192.7	212.0	262.1
D	5.00	6.00	7.00	8.50	8.60	13.00
mm	127.0	152.4	177.0	215.9	216.4	330.2

OPTIONAL MOUNTING PLATES

	MXB16	MXB25	MXB32	MXB40	MXB50	MXB63
AA	0.63	0.63	0.75	1.00	1.25	1.00
mm	15.9	15.9	19.1	25.4	31.8	25.4
BB	0.25	0.25	0.30	-	-	-
mm	6.4	6.4	7.6	-	-	-
DD	2.4	3.06	3.75	4.18	5.01	6.04
mm	60.9	77.7	95.2	106.1	127.4	153.3
EE	2.36	2.50	3.40	5.00	5.60	8.00
mm	60.0	63.5	86.4	127.0	142.2	203.2
FF	1.75	2.00	2.75	4.41	5.00	7.00
mm	44.5	50.8	59.9	112.0	127.0	177.8
GG	1.00	1.00	1.00	0.79	0.79	1.00
mm	25.4	25.4	25.4	20.1	20.1	25.4
HH	Ø.22 THRU └┘0.37 └┘.22 (2)	Ø.22 THRU └┘0.37 └┘.22 (2)	Ø.28 THRU └┘0.44 └┘.28 (2)	Ø.28 THRU (2)	Ø.28 THRU (2)	Ø.28 THRU (2)
mm	Ø5.6 THRU └┘09.4 └┘5.6 (2)	Ø5.6 THRU └┘09.4 └┘5.6 (2)	Ø7.1 THRU └┘11.2 └┘7.1 (2)	Ø7.1 THRU (2)	Ø7.1 THRU (2)	Ø7.1 THRU (2)

OPTIONAL TUBE CLAMPS

	MXB16	MXB25	MXB32	MXB40	MXB50	MXB63
JJ	-	2.24	2.92	3.26	3.84	5.19
mm	-	57.0	74.1	82.7	97.5	131.7
KK	-	2.72	3.44	3.81	4.39	5.93
mm	-	69.0	87.4	96.7	111.5	150.7
LL	-	0.71	0.63	0.55	0.55	0.75
mm	-	18.0	16.0	14.0	14.0	19.0
MM	-	0.14	0.17	0.15	0.15	0.24
mm	-	3.6	4.3	3.8	3.8	6.1
NN	-	0.20	0.28	0.28	0.28	0.42
mm	-	5.2	7.1	7.1	7.1	10.7

OPTIONAL FLOATING MOUNT

	MXB16	MXB25	MXB32	MXB40	MXB50	MXB63
PP	1.86	2.52	3.37	4.32	5.04	6.10
mm	47.2	64.1	93.3	109.7	128.0	154.9
RR	0.98	1.25	2.76	3.94	3.94	5.00
mm	24.9	31.8	70.1	100.0	100.0	127.0
SS	0.47	0.63	1.97	2.95	3.15	3.94
mm	11.9	15.9	50.0	74.9	80.0	100.1
TT	-	-	-	2.17	-	2.76
mm	-	-	-	55.1	-	70.1
UU	Ø.18 (2)	Ø.24 (2)	Ø.28 (2)	Ø.28 (4)	Ø.36 (2)	Ø.34 (4)
mm	Ø4.6 (2)	Ø6.1 (2)	Ø7.1 (2)	Ø7.1 (4)	Ø9.1 (2)	Ø8.6 (4)
VV	2.30	2.79	3.67	4.26	5.24	6.18
mm	58.5	70.9	93.3	108.2	133.1	156.8

MXB-P Rodless Belt Drive Actuator

PROFILED RAIL BEARING DIMENSIONS

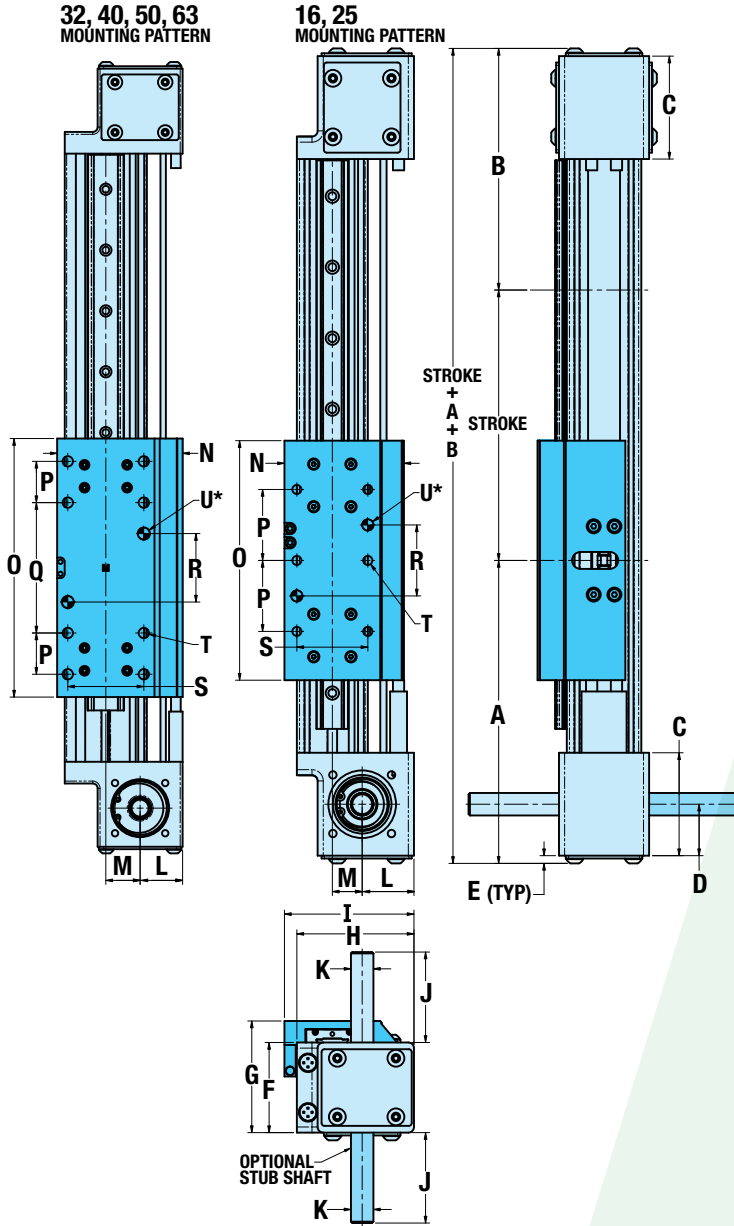

	MXB16	MXB25	MXB32	MXB40	MXB50	MXB63
A	5.33	6.85	7.39	8.53	8.85	10.83
mm	135.3	173.9	187.8	216.6	224.7	275.1
B	4.69	5.49	6.09	7.59	8.07	10.33
mm	119.0	139.3	154.7	192.7	205.0	262.1
C	2.00	2.28	2.20	3.10	3.25	3.79
mm	50.8	58.0	55.9	78.7	82.6	96.1
D	1.00	1.14	1.00	1.55	1.58	1.79
mm	25.4	29.0	25.4	39.4	40.0	45.3
E	0.15	0.17	0.17	0.17	0.17	0.17
mm	3.8	4.4	4.4	4.4	4.4	4.4
F	1.75	2.00	2.75	3.25	3.88	4.38
mm	44.5	50.8	69.9	82.6	98.4	111.1
G	2.10	2.48	3.33	3.88	5.10	5.73
mm	53.2	62.9	84.6	98.7	129.6	145.6
H	2.08	2.60	3.05	3.69	4.35	5.48
mm	52.8	66.0	77.5	93.8	110.6	139.3
I	2.16	2.87	3.25	4.09	4.64	5.79
mm	54.8	73.0	82.5	103.9	117.9	147.1
J	**	2.27	2.27	1.87	1.87	1.87
mm	**	57.7	57.7	47.5	47.5	47.5
K	0.375	0.500	0.500	0.500	0.500	0.500
mm	09.53	012.70	012.70	012.70	012.70	012.70
L	1.04	1.15	1.10	1.56	1.63	2.06
mm	26.4	29.2	27.9	39.7	41.5	52.2
M	0.45	0.66	0.89	0.87	1.17	1.46
mm	11.4	16.8	22.6	22.2	29.8	37.1
N	1.78	2.65	3.25	3.85	4.62	5.93
mm	45.3	67.4	82.5	97.8	117.4	150.6
O	4.33	5.31	6.69	7.87	8.50	12.00
mm	110.0	135.0	170.0	200.0	216.0	304.8
P	1.57	1.57	1.07	1.00	1.00	1.57
mm	40.0	40.0	27.1	25.4	25.4	40.0
Q	—	—	3.37	4.50	2.75	5.12
mm	—	—	87.7	114.3	69.8	130.0
R	1.575	1.575	1.772	2.500	1.500	2.559
mm	40.00	40.00	45.00	63.50	38.10	65.00
S	1.102	1.575	1.969	2.835	3.125	3.870
mm	28.00	40.00	50.00	72.00	79.38	98.30
T	#8-32(6)	1/4-20(6)	5/16-18(8)	5/16-18(8)	5/16-18(8)	3/8-16(8)
mm	M4x0.7	M6x1.0	M8x1.25	M8x1.25	M8x1.25	M10x1.5
U*	0.1583 / .1573 (2) ↓.250	0.2520 / .2510 (2) ↓.250	0.3145 / .3135 (2) ↓.375	0.3145 / .3135 (2) ↓.500	0.3145 / .3135 (2) ↓.500	0.3770 / .3760 (2) ↓.500
mm	04.045 / 4.020 ↓6.35	06.045 / 6.020 ↓6.35	08.045 / 8.020 ↓9.53	08.045 / 8.020 ↓12.70	08.045 / 8.020 ↓12.70	010.045 / 10.020 ↓12.70

** MXB16
(LMI) J 0.59
mm 15.0
(RP) J 1.83
mm 46.6

*DOWEL HOLES

⊕	0.003 in (M)
⊕	0.08 mm (M)

MXB-P Rodless Belt Drive Actuator

3D CAD available at www.tolomatic.com Toll Free Phone (877) SERV098
 Always use configured CAD solid model to determine critical dimensions. www.tolomatic.com

PROFILED RAIL BEARING OPTION DIMENSIONS

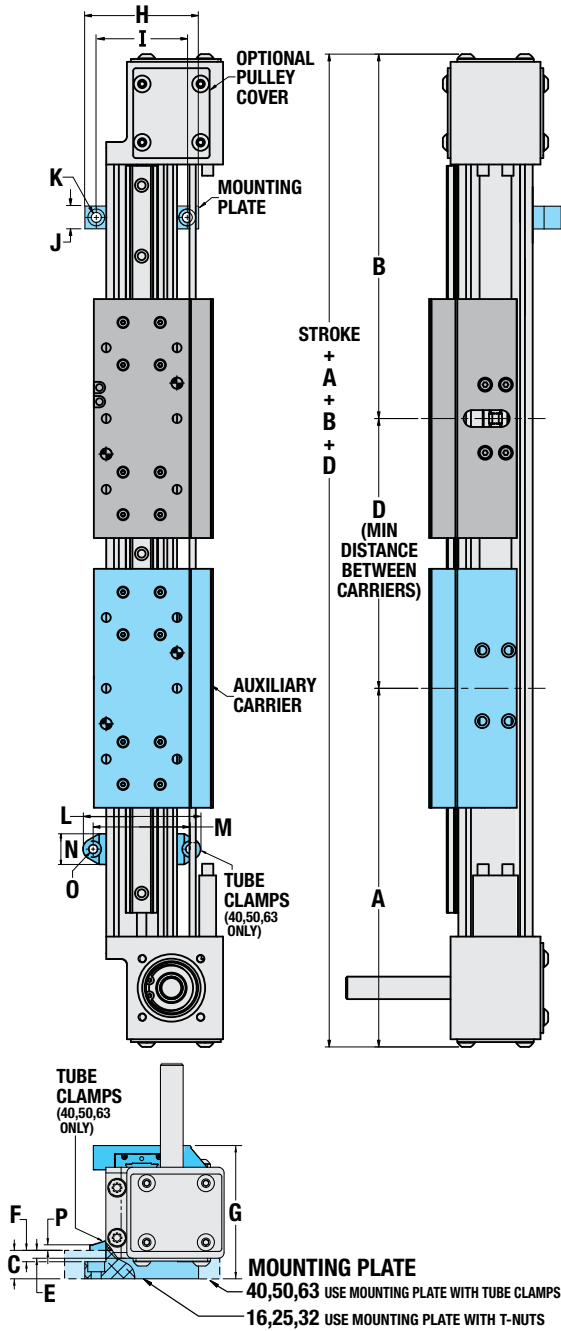

	MXB16	MXB25	MXB32	MXB40	MXB50	MXB63
A	5.33	6.85	7.39	8.53	8.85	10.83
<i>mm</i>	<i>135.3</i>	<i>173.9</i>	<i>187.8</i>	<i>216.6</i>	<i>224.7</i>	<i>275.1</i>
B	4.69	5.49	6.09	7.59	8.07	10.33
<i>mm</i>	<i>119.0</i>	<i>139.3</i>	<i>154.7</i>	<i>192.7</i>	<i>205.0</i>	<i>262.1</i>
AUXILIARY CARRIER						
D	5.00	6.00	7.00	8.50	8.60	13.00
<i>mm</i>	<i>127.0</i>	<i>152.4</i>	<i>177.0</i>	<i>215.9</i>	<i>216.4</i>	<i>330.2</i>
MOUNTING PLATE						
C	0.63	0.63	0.75	1.00	1.25	1.00
<i>mm</i>	<i>15.9</i>	<i>15.9</i>	<i>19.1</i>	<i>25.4</i>	<i>31.8</i>	<i>25.4</i>
E	0.28	0.17	0.29	0.37	0.39	0.22
<i>mm</i>	<i>7.2</i>	<i>4.4</i>	<i>7.2</i>	<i>9.3</i>	<i>9.8</i>	<i>5.6</i>
F	0.25	0.25	0.30	-	-	-
<i>mm</i>	<i>6.4</i>	<i>6.4</i>	<i>7.6</i>	-	-	-
G	2.44	2.93	3.80	4.52	5.96	6.51
<i>mm</i>	<i>61.9</i>	<i>74.4</i>	<i>96.5</i>	<i>114.8</i>	<i>151.4</i>	<i>165.4</i>
H	2.36	2.50	3.40	5.00	5.60	8.00
<i>mm</i>	<i>60.0</i>	<i>63.5</i>	<i>86.4</i>	<i>127.0</i>	<i>142.2</i>	<i>203.2</i>
I	1.75	2.00	2.75	4.41	5.00	7.00
<i>mm</i>	<i>44.5</i>	<i>50.8</i>	<i>69.9</i>	<i>112.0</i>	<i>127.0</i>	<i>177.8</i>
J	1.00	1.00	1.00	0.79	0.79	1.00
<i>mm</i>	<i>25.4</i>	<i>25.4</i>	<i>25.4</i>	<i>20.1</i>	<i>20.1</i>	<i>25.4</i>
K	Ø.22 THRU └┘0.37 ┆.22 (2)	Ø.22 THRU └┘0.37 ┆.22 (2)	Ø.28 THRU └┘0.44 ┆.28 (2)	Ø.28 THRU (2)	Ø.28 THRU (2)	Ø.28 THRU (2)
<i>mm</i>	<i>Ø5.6 THRU</i> <i>└┘Ø9.4</i> <i>┆5.6 (2)</i>	<i>Ø5.6 THRU</i> <i>└┘Ø9.4</i> <i>┆5.6 (2)</i>	<i>Ø7.1 THRU</i> <i>└┘Ø11.2</i> <i>┆7.1 (2)</i>	<i>Ø7.1</i> <i>THRU (2)</i>	<i>Ø7.1</i> <i>THRU (2)</i>	<i>Ø7.1</i> <i>THRU (2)</i>
TUBE CLAMPS						
L	-	-	-	3.81	4.39	5.93
<i>mm</i>	-	-	-	<i>96.8</i>	<i>111.5</i>	<i>150.6</i>
M	-	-	-	3.26	3.84	5.19
<i>mm</i>	-	-	-	<i>82.8</i>	<i>97.5</i>	<i>131.8</i>
N	-	-	-	0.55	0.55	0.75
<i>mm</i>	-	-	-	<i>14.0</i>	<i>14.0</i>	<i>19.1</i>
O	-	-	-	0.28	0.28	0.42
<i>mm</i>	-	-	-	<i>7.1</i>	<i>7.1</i>	<i>10.7</i>
P	-	-	-	0.15	0.15	0.24
<i>mm</i>	-	-	-	<i>3.8</i>	<i>3.8</i>	<i>6.1</i>

MXB Rodless Belt Drive Actuator

DIRECT DRIVE MOTOR MOUNTING

MXB-U

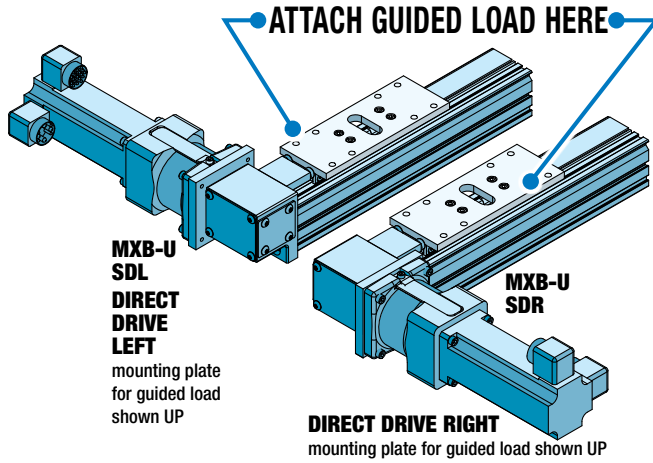

MXB-S

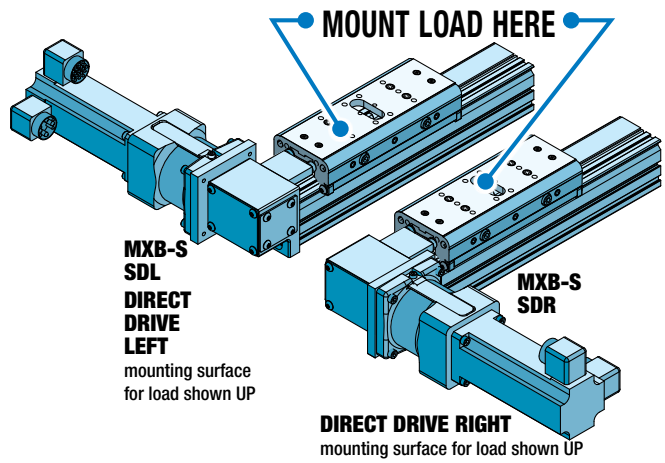

MXB-P

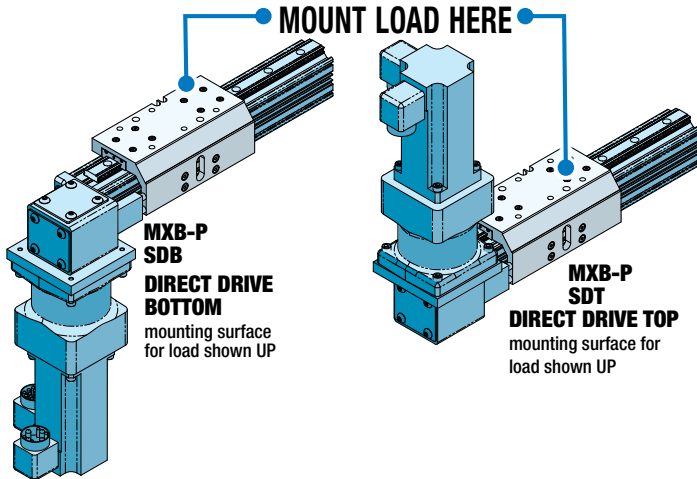

MOTOR MOUNTING

The MXB-P is unique among Tolomatic belt drive actuators. The mounting surface of the carrier is located 90° from the motion of the belt. The side opposite the belt is reserved for switch placement. The bottom of the actuator is reserved for mounting. If the motor is mounted in the SDT (direct drive top orientation), be sure the load mounted to the carrier does not interfere with the motor.



LARGE FRAME MOTORS AND SMALLER SIZE ACTUATORS: Cantilevered motors need to be supported if subjected to continuous rapid reversing duty and/or under dynamic conditions.

MXB Rodless Belt Drive Actuator

3D CAD available at www.tolomatic.com
 Toll Free Phone (877) SERV098
 Always use configured CAD solid model to determine critical dimensions.
 Fax (7) SERV099
www.tolomatic.com

REDUCTION DRIVE MOTOR MOUNTING

MXB-U

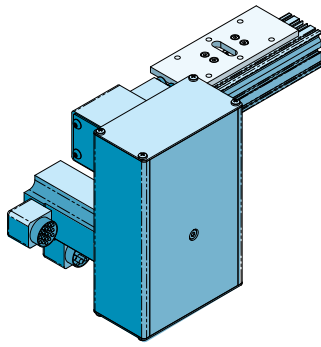

**REDUCTION DRIVE
BOTTOM LEFT (SDBL)**
mounting plate
for guided load shown UP

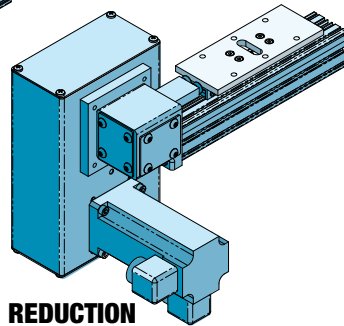

**REDUCTION
DRIVE
BOTTOM RIGHT (SDBR)**
mounting plate for
guided load shown UP

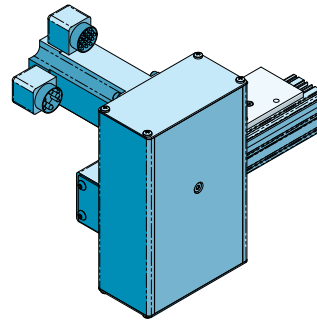

**REDUCTION DRIVE
TOP LEFT (SDTL)**
mounting plate for
guided load shown UP

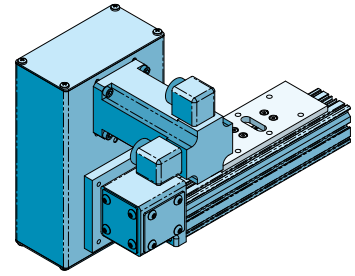

**REDUCTION DRIVE
TOP RIGHT (SDTR)**
mounting plate for
guided load shown UP

MXB-S

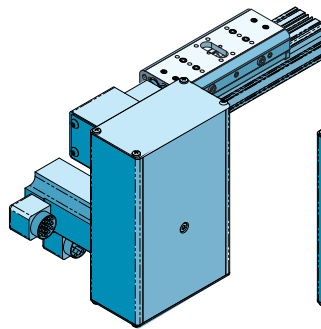

**REDUCTION DRIVE
BOTTOM LEFT (SDBL)**
mounting surface
for load shown UP

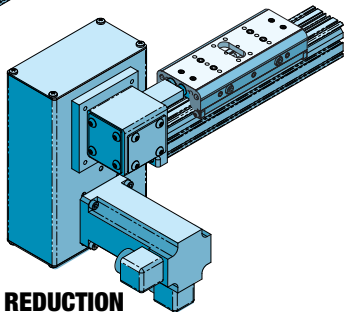

**REDUCTION
DRIVE
BOTTOM RIGHT (SDBR)**
mounting surface for load
shown UP

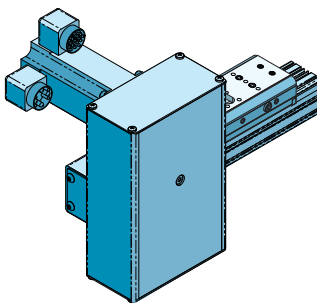

**REDUCTION DRIVE
TOP LEFT (SDTL)**
mounting surface
for load shown UP

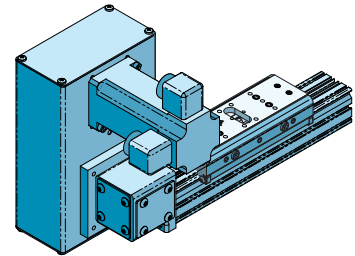

**REDUCTION DRIVE
TOP RIGHT (SDTR)**
mounting surface
for load shown UP

MXB-P

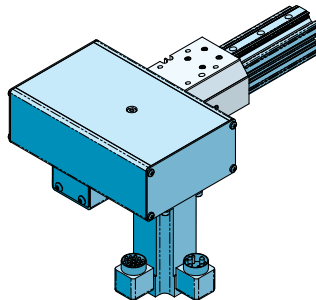

**REDUCTION DRIVE
RIGHT BOTTOM (SDBR)**
mounting surface
for load shown UP

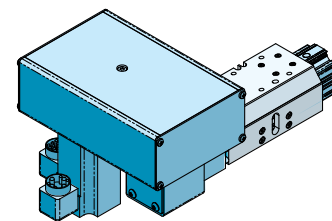

**REDUCTION DRIVE
LEFT BOTTOM (SDLB)**
mounting surface
for load shown UP

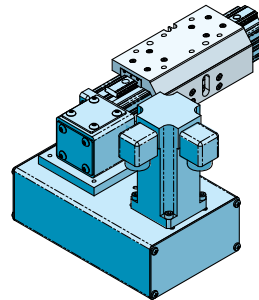

**REDUCTION DRIVE
RIGHT TOP (SDRT)**
mounting surface
for load shown UP

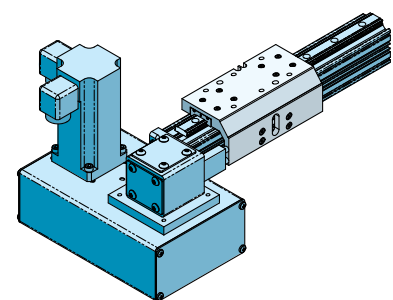

**REDUCTION DRIVE
LEFT TOP (SDLT)**
mounting surface
for load shown UP

See tolomatic.com for 3D solid model(s) with motor mounting dimensions

MXB Rodless Belt Drive Actuator

SWITCHES SPECIFICATIONS



MX products offer a wide range of sensing choices. There are 12 switch choices: reed, solid state PNP (sourcing) or solid state NPN (sinking); in normally open or normally closed; with flying leads or quick-disconnect.

Commonly used for end-of-stroke positioning, these switches allow drop-in installation anywhere along the entire actuator length. The one-piece design includes the retained fastening hardware. The magnet and magnet hardware are located on the carrier. See the dimensional drawings on page MXB_23 for details of magnet and switch locations. Switches and magnets can be installed in the field at any time.

Switches are used to send digital signals to PLC (programmable logic controller), TTL, CMOS circuit or other controller device. Switches contain reverse polarity protection. Solid state QD cables are shielded; shield should be terminated at flying lead end.

All switches are CE rated and are RoHS compliant. Switches feature bright red or yellow LED signal indicators; solid state switches also have green LED power indicators.

	Order Code	Part Number	Lead	Switching Logic	Power LED	Signal LED	Operating Voltage	**Power Rating (Watts)	Switching Current (mA max.)	Current Consumption	Voltage Drop	Leakage Current	Temp. Range	Shock / Vibration
REED	R Y	8100-9082	5m	SPST Normally Open	—	Red	5 - 240 AC/DC	**10.0	100mA	—	3.0 V max.	—	14 to 158°F [-10 to 70°C]	50 G / 9 G
	R K	8100-9083	QD*											
	N Y	8100-9084	5m	SPST Normally Closed	—	Yellow	5 - 110 AC/DC							
	N K	8100-9085	QD*											
SOLID STATE	T Y	8100-9088	5m	PNP (Sourcing) Normally Open	Green	Yellow	10 - 30 VDC	**3.0	100mA	20 mA @ 24V	2.0 V max.	0.05 mA max.		
	T K	8100-9089	QD*											
	K Y	8100-9090	5m	NPN (Sinking) Normally Open	Green	Red								
	K K	8100-9091	QD*											
	P Y	8100-9092	5m	PNP (Sourcing) Normally Closed	Green	Yellow								
	P K	8100-9093	QD*											
	H Y	8100-9094	5m	NPN (Sinking) Normally Closed	Green	Red								
	H K	8100-9095	QD*											

*QD = Quick-disconnect

Enclosure classification IEC 529 IP67 (NEMA 6)

CABLES: Robotic grade, oil resistant polyurethane jacket, PVC insulation

WARNING: Do not exceed power rating (Watt = Voltage x Amperage). Permanent damage to sensor will occur.

SWITCH INSTALLATION AND REPLACEMENT

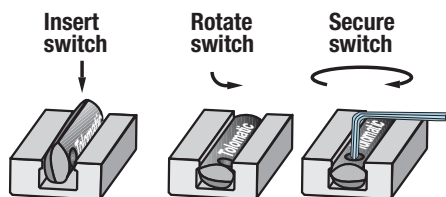

Place switch in side groove on tube at desired location with "Tolomatic" facing outward. While applying light pressure to the switch, rotate the switch halfway into the groove. Maintaining light pressure, rotate the switch in the opposite direction until it is fully inside the groove with "Tolomatic" visible. Re-position the switch to the exact location and lock the switch securely into place by tightening the screw on the switch.

MXB Rodless Belt Drive Actuator

SWITCHES

WIRING DIAGRAMS

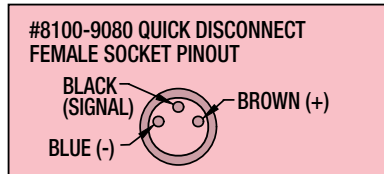
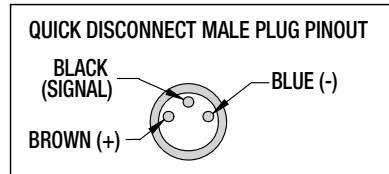
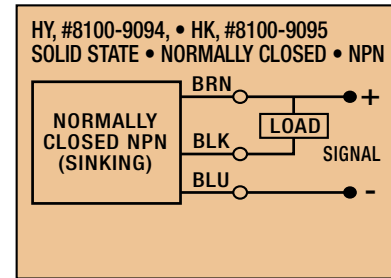
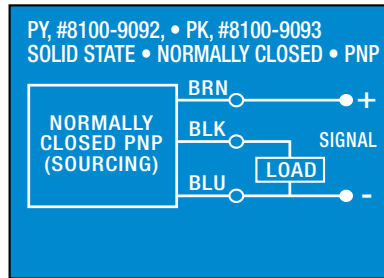
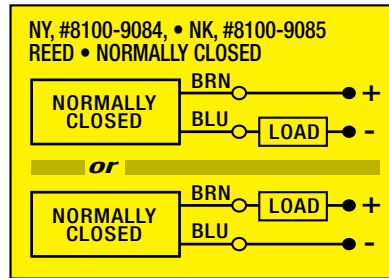
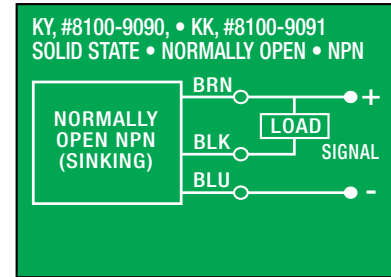
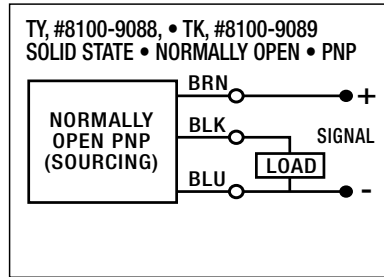
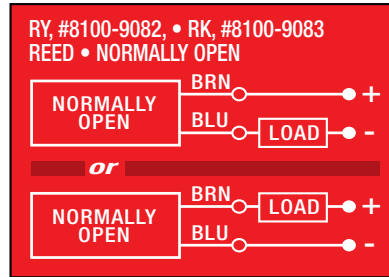

MOUNTING DIMENSIONS

MXB-U

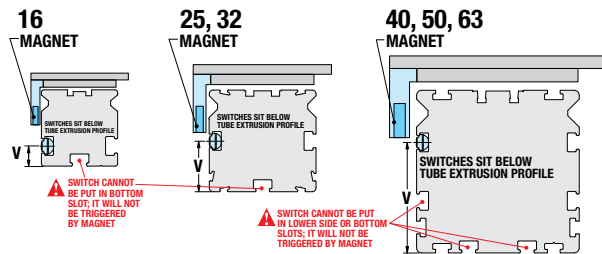

MXB-S

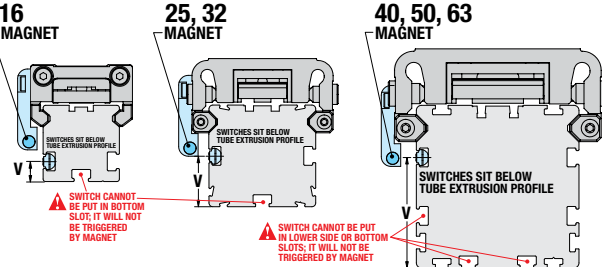

MXB-P

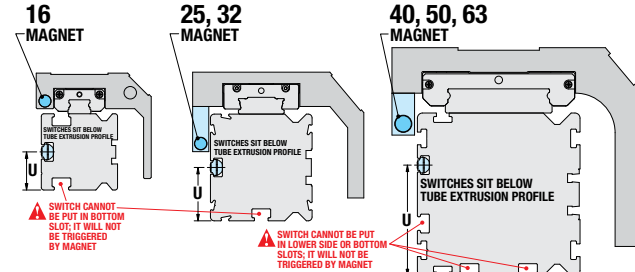

SWITCH DIMENSIONS

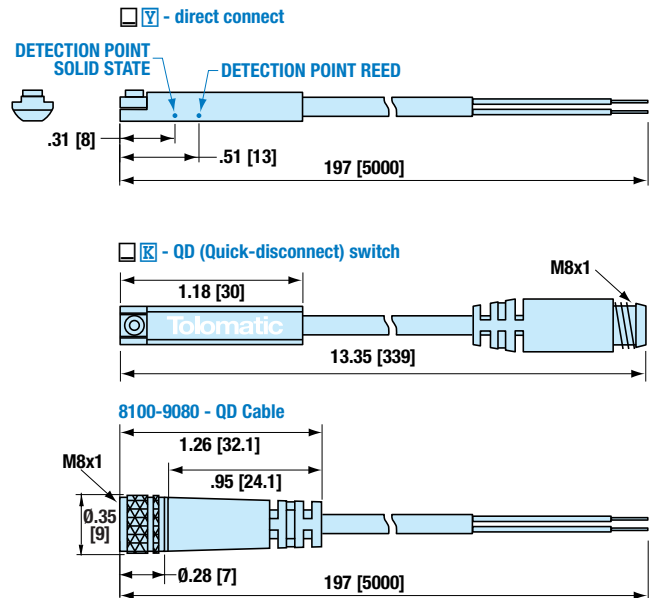

Dimensions in inches [brackets indicate dimensions in millimeters]

SWITCH MOUNTING

	16	25	32	40	50	63
U	0.59	0.83	1.09	1.71	2.02	2.44
<i>mm</i>	15.0	21.0	27.7	43.5	51.4	62.0
V	0.31	0.79	1.06	1.71	2.02	2.44
<i>mm</i>	7.9	20.0	27.0	43.5	51.4	62.0

NOTE: When ordering switches as a service part, Magnet Housing Kit (light blue in drawings) is required if actuator was not originally ordered with switches.

APPLICATION DATA WORKSHEET

Fill in known data. Not all information is required for all applications

ORIENTATION

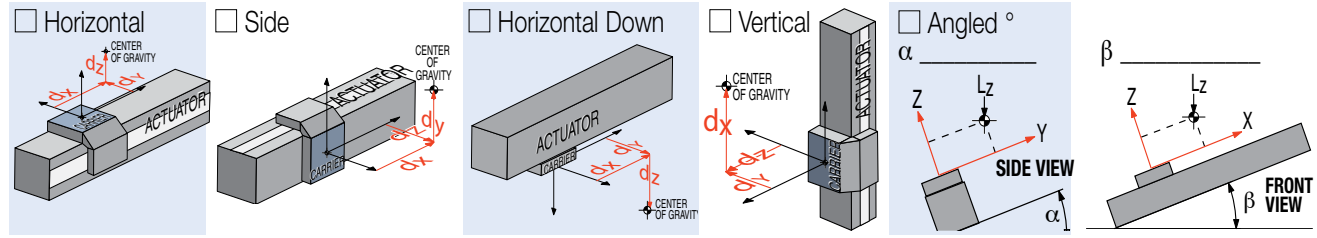

Load attached to carrier OR Load supported by other mechanism

DISTANCE FROM CENTER OF CARRIER TO LOAD CENTER OF GRAVITY

d_x _____
 d_y _____
 d_z _____

inch (U.S. Standard) millimeters (Metric)

STROKE LENGTH

inch (S&K) (U.S. Standard) millimeters (S&M) (Metric)

NOTE: If load or force on carrier changes during cycle use the highest numbers for calculations

LOAD

lb. (U.S. Standard) kg. (Metric)

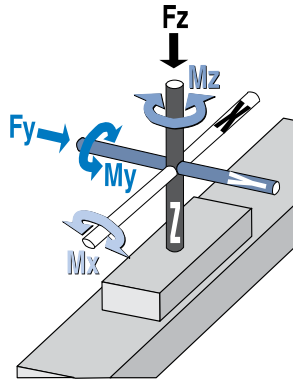

FORCES APPLIED TO CARRIER

lbf. (U.S. Standard) N (Metric)

F_z _____
 F_y _____

BENDING MOMENTS APPLIED TO CARRIER

in.-lbs. (U.S. Standard) N-m (Metric)

M_x _____
 M_y _____
 M_z _____

PRECISION

Repeatability _____
 inch millimeters

OPERATING ENVIRONMENT

Temperature, Contamination, etc.

MOVE PROFILE

Move Distance _____

inch millimeters

Dwell Time After Move _____

Max. Speed _____

in/sec mm/sec

MOVE TIME

sec

NO. OF CYCLES

per minute per hour

MOTION PROFILE

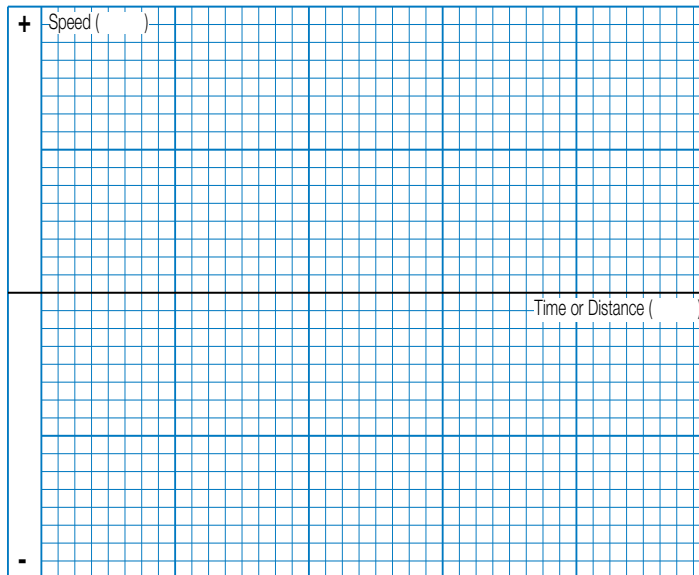

Graph your most demanding cycle, including accel/decel, velocity and dwell times. You may also want to indicate load variations and I/O changes during the cycle. Label axes with proper scale and units.

CONTACT INFORMATION

Name, Phone, Email _____
 Co. Name, Etc. _____

STOP USE THE TOLOMATIC ON-LINE SIZING AND SELECTION AT www.tolomatic.com OR... CALL TOLOMATIC AT 1-800-328-2174.

We will provide any assistance needed to determine the proper MX actuator for the job.

FAX 1-763-478-8080

EMAIL help@tolomatic.com

SELECTION GUIDELINES

The process of selecting a belt drive actuator for a given application can be complex. It is highly recommended that you contact Tolomatic or a Tolomatic distributor for assistance in selecting the best actuator for your application. The following overview of the selection guidelines are for educational purposes only.

1 CHOOSE ACTUATOR SIZE

Choose an actuator that has the thrust, speed and moment load capacity to move the load.

- A) For maximum thrust use the table below.
- B) Max. speed of MXB-U 200 in/sec (5 m/sec); Max. speed of MXB-S 100 in/sec (2.5 m/sec) Max. speed of MXB-P 150 in/sec (3.8 m/sec).
- C) For MXB-S moment and load capacities see tables on page MXB_12. For MXB-P moment and load capacities see tables on page MXB_13.

SIZE	MAXIMUM THRUST	
	lbf	N
16	38	169
25	151	672
32	209	930
40	250	1112
50	325	1446
63	418	1859

2 COMPARE LOAD TO MAXIMUM LOAD CAPACITIES

Calculate the application load (combination of load mass and forces applied to the carrier) and application bending moments (sum of all moments M_x , M_y , and M_z applied to the carrier). Be sure to evaluate the magnitude of dynamic inertia moments. When a rigidly attached load mass is accelerated or decelerated, its inertia induces bending moments on the carrier. Careful attention to how the load is decelerated at the end of the stroke is required for improved actuator performance and application safety. If either load or any of the moments exceed figures indicated in the Moment and Load Capacity tables (page MXB_12 & 13) for the actuator consider:

- 1) A higher capacity carrier (ie. **S** to **P**)
- 2) A larger actuator size

3) Auxiliary carrier

4) External guide system (if the load is externally supported and guided, consider using MXB-U)

3 CALCULATE LOAD FACTOR (LF)

For loads with a center of gravity offset from the carrier account for both applied (static) and dynamic loads. The load factor (LF) must not exceed the value of 1.

$$L_f = \frac{M_x}{M_{x_{max}}} + \frac{M_y}{M_{y_{max}}} + \frac{M_z}{M_{z_{max}}} + \frac{F_y}{F_{y_{max}}} + \frac{F_z}{F_{z_{max}}} \leq 1$$

If L_f does exceed the value of 1, consider the four choices listed in step #2.

4 ESTABLISH YOUR MOTION PROFILE AND CALCULATE ACCELERATION RATE

Using the application stroke length and maximum carrier velocity (or time to complete the linear motion), establish the motion profile. Select either triangular (accel-decel) or trapezoidal (accel-constant speed-decel) profile. Now calculate the maximum acceleration and deceleration rates of the move. Acceleration/ deceleration should not exceed 1200 in/sec² (30.48 m/sec²). Also, do not exceed safe rates of dynamic inertia moments determined in step #3.

SPEED FACTOR

FOR APPLICATIONS WITH HIGH SPEED OR SIGNIFICANT SHOCK AND VIBRATION: Calculated values of loads and bending moments must be increased by speed factor from the graph below to obtain full rated life of profiled rail bearing system.

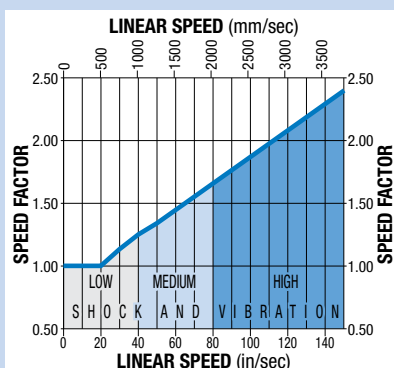

5 SELECT MOTOR (GEARHEAD IF NECESSARY) AND DRIVE

To help select a motor and drive, use the sizing equations located in the Engineering Resources section of the Tolomatic Electric Products Catalog (#3600-4609) to calculate the application thrust and torque requirements. Refer to Motor sections to determine the motor and drive.

6 DETERMINE MOUNTING PLATE REQUIREMENTS

- Consult the Mounting Plate Requirements graph for the model selected (page MXB_11)
- Cross reference the application load and maximum distance between supports
- Select the appropriate number of mounting plates

7 CONSIDER OPTIONS

- Choose metric or inch (U.S. standard) load mounting. When ordering use **SIX** for inch and **SIM** for metric.
- Switches - Reed, Solid State PNP or NPN, all available normally open or normally closed
- **FIL** Floating mount bracket - used when lack of parallelism occurs between the actuator and an externally guided and supported load (available for **S** Solid bearing style MXB actuators)



USE THE TOLOMATIC SIZING AND SELECTION SOFTWARE AVAILABLE ON-LINE AT www.tolomatic.com OR... CALL TOLOMATIC AT 1-800-328-2174. We will provide any assistance needed to determine the proper MX actuator for the job.

S SOLID BEARING 2:1 RULE

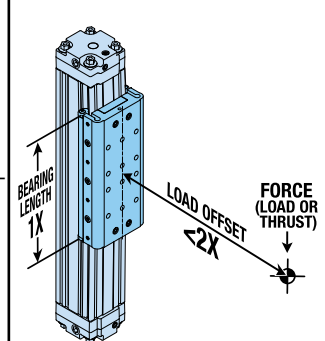

For applications using **S** solid bearings, binding or interrupted motion may occur if the load offset is equal to or greater than twice the bearing length (1X). **LOAD OFFSET** is defined as: the distance from the applied force (or the load center of gravity) to the centerline of the carrier.

If the load offset cannot be changed consider:













- 1.) Higher capacity bearing style, i.e. **S** to **P**
- 2.) Larger actuator size
- 3.) Auxiliary carrier
- 4.) Add external guides

MXB Rodless Belt Drive Actuators

SERVICE PARTS ORDERING

SWITCHES

Switches for MXB include retained mounting hardware and are the same for all actuator sizes and bearing styles



Code	Part Number	Lead	Normally	Sensor Type
	8100-9082	5m (197 in)	Open	Reed
	8100-9083*	Quick-disconnect		
	8100-9084	5m (197 in)	Closed	Reed
	8100-9085*	Quick-disconnect		
	8100-9088	5m (197 in)	Open	Solid State PNP
	8100-9089*	Quick-disconnect		
	8100-9090	5m (197 in)	Open	Solid State NPN
	8100-9091*	Quick-disconnect		
	8100-9092	5m (197 in)	Closed	Solid State PNP
	8100-9093*	Quick-disconnect		
	8100-9094	5m (197 in)	Closed	Solid State NPN
	8100-9095*	Quick-disconnect		

*Also order mating QD cable #8100-9080

	8100-9080	Mating QD (Quick-disconnect) cable 197 in. (5m)
---	-----------	---

⚠ NOTE: When ordering switches as service part, Magnet Housing Kit is required if actuator was not originally ordered with switches

OPTIONS

MXB SIZE	Mounting Plate Kit	 (inch) Floating Mount Kit	 (metric) Floating Mount Kit	**MXB-U Magnet Housing Kit	**MXB-S Magnet Housing Kit	**MXB-P Magnet Housing Kit
16	8516-9030	8116-9536	8116-9036	8516-9024	8516-9074	8340-1008
25	8525-9030	8525-9536	8525-9136	8525-9024	8525-9074	8525-9009
32	8532-9030	8132-9536	8132-9036	8525-9024	8532-9074	8532-9009
40	8540-9030	8140-9536	8140-9036	8525-9024	8540-9074	8540-9009
50	8550-9030	8550-9536	8550-9036	8550-9024	8550-9074	8550-9009
63	8563-9030	8163-9536	8163-9036	8550-9024	8563-9074	8563-9009

***Magnet Housing Kit is required if actuator was not originally ordered with switches

⚠ [Click here for a video of MX_-S carrier adjustment procedures](#)

ACS SERVO & STEPPER DRIVES WITH ETHERNET



STEPPER & BRUSHLESS SERVO MOTORS

- Motors • Drives • Gearboxes

Tolomatic offers digital servo or stepper drives with motors matched to provide optimal performance with Tolomatic actuators.

SELECT A COMPLETE SYSTEM FROM TOLOMATIC OR ADD ANY MOTION SYSTEM TO OUR ACTUATORS

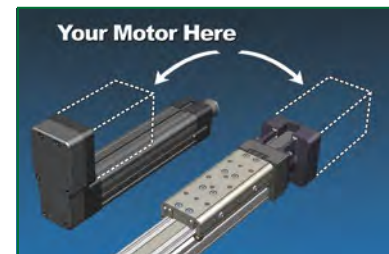

"YOUR MOTOR HERE" MADE-TO-ORDER MOTOR MOUNTS. 15 DAYS.

- Select a high-performance Tolomatic electric actuator and we'll provide a motor-specific interface for your motor. With our online database, you can select from over 60 motor manufacturers and hundreds of models.

Visit www.tolomatic.com/yhm to find your motor/actuator match!

Configure an actuator and a complete motion control system today using Tolomatic's easy-to-use on-line sizing & selection



Available FREE at www.tolomatic.com

MXB Rodless Belt Drive Actuators

ORDERING

MODEL SELECTION (MUST BE IN THIS ORDER)

MXB 40 P BWS30 SM2007-02

OPTIONS (IN ANY ORDER)

SDB DC215-9 MP8 HC2 TK2

MODEL
MXB MX Rodless Belt Drive Actuators

SERIES
16 Series actuator 40 Series actuator
25 Series actuator 50 Series actuator
32 Series actuator 63 Series actuator

BEARING
U Unguided Carrier
S Solid Bearing Carrier
P Profiled Rail Bearing Carrier

BELT MATERIAL AND WIDTH
BWS10 10 mm Urethane Steel (MXB16)
BWS18 18 mm Urethane Steel (MXB25)
BWS25 25 mm Urethane Steel (MXB32)
BWS30 30 mm Urethane Steel (MXB40)
BWS40 40 mm Urethane Steel (MXB50)
BWS50 50 mm Urethane Steel (MXB63)

STROKE LENGTH & MOUNTING TYPE
SK _____ Stroke, enter desired stroke length in **inches**
SM _____ Stroke, enter desired stroke length in **millimeters**
GPB Blank Plate (MXB-U only)
NO MOUNTING HOLES allowing user to drill and tap as needed
NOTE: Actuator mounting threads and mounting fasteners will be either inch or metric, depending on how stroke length is indicated
SK=inch mounting
SM= metric mounting

U & S MOTOR MOUNTING/REDUCTION
(must choose one)
SDL, SDL D* Direct Drive on Left
SDR, SDR D* Direct Drive on Right
▲ A motor size and code must be selected when specifying a 3:1 reduction. Reference the motor ordering pages in Electric Products Catalog #3600-4609.
SDTL, SDTLD* 3:1 Reduction on Top Left
SDTR, SDTRD* 3:1 Reduction on Top Right
SDBL, SDBLD* 3:1 Reduction on Left Bottom
SDBR, SDBRD* 3:1 Reduction on Right Bottom
***For Dual Stub Shaft Option**

P MOTOR MOUNTING / REDUCTION
(must choose one)
SDT, SDTD* Direct Drive on Top
SDB, SDBD* Direct Drive on Bottom
▲ A motor size and code must be selected when specifying a 3:1 reduction. Reference the motor ordering pages in Electric Products Catalog #3600-4609.
SDLT, SDLTD* 3:1 Reduction on Left Top
SDRT, SDRTD* 3:1 Reduction on Right Top
SDLB, SDLBD* 3:1 Reduction on Left Bottom
SDRB, SDRBD* 3:1 Reduction on Right Bottom
***For Dual Stub Shaft Option**

AUXILIARY CARRIER
DC _____ Auxiliary Carrier, (MXB-P only) enter center-to-center spacing desired in **inches (SK)** or **millimeters (SM)**
(Same unit of measure as stroke length is required)
▲ Center-to-center spacing between carriers adds to overall length of the actuator, this distance will not be subtracted from stroke length specified in the previous step

HEAD COVER PLATES
HC2 Head Cover Plates

MOUNTING
MP_ Mounting Plates, & quantity
TC_ Tube Clamps, & quantity
NOTE: The MXB requires Mounting Plates to allow clearance for motor when mounted flush to surface. 16,25,32 sizes use T-Nuts with Mounting Plates. 40,50,63 sizes use Tube Clamps with Mounting Plates.

P CARRIER ORIENTATION
BIR Mirrored Carrier Design

MOTOR / DRIVE / CONTROLLER / PLANETARY GEARBOX
▲ Reference the ordering pages in Tolomatic Electric Product Brochures Stepper Products Brochure #3600-4160 & Planetary Gearbox Doc. #3600-4161

		SWITCHES					
TYPE	LOGIC	NORMALLY	QUICK-DISCONNECT	CODE	QUANTITY	LEAD LENGTH	
REED	SPST	Open	no	RY	After code enter quantity desired	5 meters (16.4 feet)	
			QD	RK			
	Closed	no	NY				
		QD	NK				
SOLID STATE	PNP	Open	no	TY			
			QD	TK			
	NPN	Open	no	KY			
			QD	KK			
	PNP	Closed	no	PY			
			QD	PK			
NPN	Closed	no	HY				
		QD	HK				



▲ Not all codes listed are compatible with all options.

Call Tolomatic 1-800-328-2174 to determine available options and accessories based on your application requirements.

VISIT www.tolomatic.com/mxb FOR COMPLETE, UP-TO-DATE INFORMATION

The Tolomatic Difference Expect More From the Industry Leader



INNOVATIVE PRODUCTS

Tolomatic designs and builds the best standard products, modified products & unique custom products for your challenging applications.



FAST DELIVERY

The fastest delivery of catalog products... Electric products are built-to-order in 15 days; Pneumatic & Power Transmission products in 5 days.



ACTUATOR SIZING

Online sizing that is easy to use, accurate and always up-to-date. Find a Tolomatic electric actuator to meet your requirements.



YOUR MOTOR HERE

Match your motor with compatible mounting plates that ship with any Tolomatic electric actuator.



LIBRARY

Easy to access CAD files available in the most popular formats to place directly into your assembly.



SUPERIOR SERVICE

Our people make the difference! Expect prompt, courteous replies to all of your application and product questions.

Also Consider These Other Tolomatic Products:

Electric Products

Rod & Guided Rod Style Actuators, High Thrust Actuators, Screw & Belt Drive Rodless Actuators, Motors, Drives and Controllers

"Foldout" Brochure #9900-9074



Pneumatic Products

Rodless Cylinders: Band Cylinders, Cable Cylinders, Magnetically Coupled Cylinders/Slides; Guided Rod Cylinder Slides

"Foldout" Brochure #9900-9075



Power Transmission Products

Gearboxes: Float-A-Shaft®, Slide-Rite®, Disc Cone Clutch; Caliper Disc Brakes

"Foldout" Brochure #9900-9076



3800 County Road 116 • Hamel, MN 55340, USA
Phone: (763) 478-8000 • Fax: (763) 478-8080
Toll-Free: 1-800-328-2174
sales@tolomatic.com • www.tolomatic.com

EUROPEAN OFFICE

Tolomatic Europe GmbH
Herriotstraße 1
60528 Frankfurt am Main
Germany
Phone: +49 69-6773-3143
EuropeSales@tolomatic.com

CHINA FACILITY

Tolomatic Automation Products (Suzhou) Co. Ltd.
(ServoWeld® inquiries only)
No. 60 Chuangye Street, Building 2
Huqiu District, SND Suzhou
Jiangsu 215011 - P.R. China
Phone: +86 (512) 6750-8506
Fax: +86 (512) 6750-8507
ServoWeldChina@tolomatic.com

All brand and product names are trademarks or registered trademarks of their respective owners. Information in this document is believed accurate at time of printing. However, Tolomatic assumes no responsibility for its use or for any errors that may appear in



this document. Tolomatic reserves the right to change the design or operation of the equipment described herein and any associated motion products without notice. Information in this document is subject to change without notice.

Visit www.tolomatic.com for the most up-to-date technical information