

## Metric Precision Ball Screws

High load capacity in a range of package sizes,  
providing precise, smooth and quiet performance

Sold & Serviced By:

 **ELECTROMATE**

Toll Free Phone (877) SERV098  
[www.electromate.com](http://www.electromate.com)  
[sales@electromate.com](mailto:sales@electromate.com)

 **THOMSON**<sup>®</sup>

*Linear Motion. Optimized.™*

## Metric Precision Ball Screw Overview (10 - 12 mm)

The ideal solution for laboratory, medical and mechatronic applications, Thomson's miniature metric rolled ball screws deliver smooth and quiet operation and best-in-class load capacity.

### Bigger Load Capacity

- Design maximizes load capacity by optimizing return system
- Quiet and smooth performance
- Enables flexible ball nut mounting configurations and rapid prototyping

### Improved Value

- Screws are precision rolled to T7 accuracy class standard
- State-of-the-art manufacturing
- Higher load capacity equates to longer life

### Genuine Thomson Quality and Innovation

- Proprietary thread form and processing equal quality and performance
- Expert technical and application support

### Ball Nut Types

| Styles  | Nominal Diameter Size Range (mm) |
|---|----------------------------------|
| Flanged Single Nut Internal Return System (FSI)     | 10 - 50                          |
| Threaded Single Nut Internal Return System (TSI)    | 10 - 12                          |
| Cylindrical Single Nut Internal Return System (RSI) | 10 - 12                          |



### Materials

| Part  | Material         |                            | Strength             |                      | Heat treatment                    | Standard Surface Finish                    |
|-------|------------------|----------------------------|----------------------|----------------------|-----------------------------------|--|
|       | 16 - 50 mm (FSI) | 10 - 12 mm (FSI, TSI, RSI) | R <sub>m</sub>       | R <sub>e</sub>       |                                   |  |
|       |                  |                            | [N/mm <sup>2</sup> ] | [N/mm <sup>2</sup> ] |                                   |  |
| Screw | Cf53             | SAE1045                    | ≥ 610                | ≥ 380                | 60 ± 2 HRC<br>Inductive hardening | Polished & Oiled                           |
| Nut   | 16MnCr5          | SAE8620                    | > 800                | > 600                | 60 ± 2 HRC<br>hardened            | Polished & Oiled<br>(optional black oxide) |
| Wiper | NBR 33           |                            |                      |                      |                                   |  |
| Ball  | 100Cr6           | SAE52100                   |                      |                      | 64 ± 2 HRC                        |  |

Special materials and heat or surface treatment on request.

Permitted temperature in continuous operation -22°F (-30°C) to 212°F (100°C). Please inquire for other applications.  
Nuts with plastic ball returns only to 176°F (80°C); briefly 230°F (110°C).

Sold & Serviced By:



Toll Free Phone (877) SERV098

[www.electromate.com](http://www.electromate.com)

[sales@electromate.com](mailto:sales@electromate.com)

### Miniature Metric Styles Ball Screws – Product Availability

| Nominal Diameter | Screw Leads |      |      |      |       |       |       |       |
|------------------|-------------|------|------|------|-------|-------|-------|-------|
|                  | [mm]        | 2 mm | 3 mm | 5 mm | 10 mm | 20 mm | 25 mm | 40 mm |
| 10               |             | •    | •    |      | •     |       |       |       |
| 12               |             | •    |      |      |       |       |       |       |

### Standard Metric Ball Screws - Product Availability

|    |  |  |   |   |   |   |   |
|----|--|--|---|---|---|---|---|
| 16 |  |  | • | • |   |   |   |
| 20 |  |  | • |   |   |   |   |
| 25 |  |  | • | • | • | • |   |
| 32 |  |  | • | • | • |   |   |
| 40 |  |  | • | • | • |   | • |
| 50 |  |  |   | • |   |   |   |

## Standard Flanged Style (16 - 50 mm)

Flanged style metric ball screw assemblies combine the engineering and performance of high-quality, German ball screws with North American manufacturing and logistics. Only 2% of all ball screws sold in North America are manufactured here, so you'll be able to take advantage of shorter lead times, reduced shipping costs, and enhanced communication with support and service. The flanged style provides the best in quality, performance and delivery at a competitive price.

- DIN 69051 compliant (flanged style 16 - 50 mm only)
- Patented Precision Screw Forming (PST) technology
- Smooth performance due to unique ball return systems
- Regionally stocked/machined/assembled product in Marengo, Illinois
- P5 accuracy screws standard
- Ground quality ball nuts



Sold & Serviced By:

 **ELECTROMATE**

Toll Free Phone (877) SERV098

[www.electromate.com](http://www.electromate.com)  
[sales@electromate.com](mailto:sales@electromate.com)

## Flanged Style Application Examples

Thomson's ball screw assemblies provide the smooth motion and positional accuracy typically found only in a ground product. These qualities, combined with the economical precision rolled solution, make them ideal for large 3-axis structures.

### Gantry

Thomson's unique ball return systems and preload capabilities reduce the effect of critical screw speed on a long slender axis (see X-axis above). Combined with the Thomson profile rail, this solution provides stiffness and accuracy to the overall system.

Smooth motion is necessary to prevent reflected inertia from causing structural vibration in large structures. The illustrated Y-axis below combines a precision flanged ball screw assembly with the alignment compensation of Thomson linear rails.



### Engraver / Laser / Waterjet Cutting

Machine tool applications have primarily been the domain of ground ball screw assemblies. The introduction of high-precision P3/P5 accuracy rolled ball screws has eliminated the need for ground product where a less expensive solution that still meets high performance standards is required.

These types of applications typically require P3/P5 accuracy, 75-100% duty cycle, harsh environments, and reversing loads or dithering issues. Flanged ball screw assemblies have molded rubber (NBR) seals as standard in sizes  $\varnothing 16$  mm and above and are ideal for these demanding parameters.

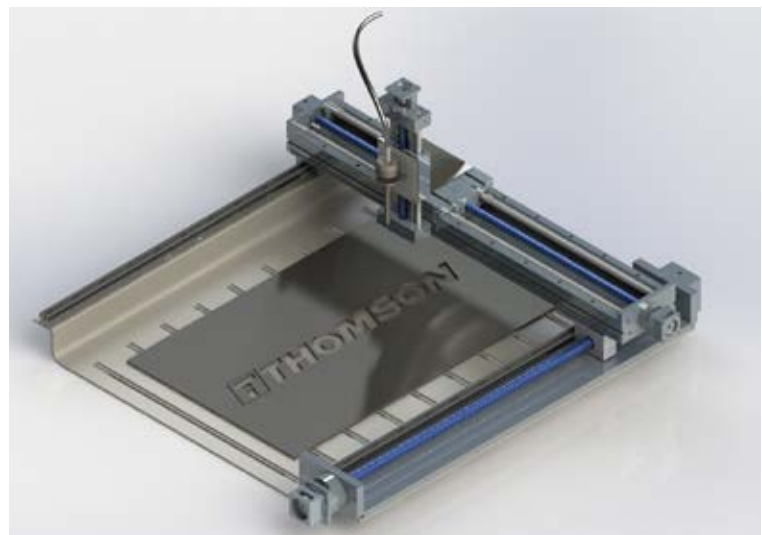

Sold & Serviced By:

 **ELECTROMATE**

Toll Free Phone (877) SERV098  
[www.electromate.com](http://www.electromate.com)  
[sales@electromate.com](mailto:sales@electromate.com)

## Metric Ball Nut Return System Overview

All ball screws require a recirculation system for the ball bearings. Thomson return systems are optimized for each diameter and lead combination to maximize load capacity, minimize footprint and guarantee smooth operation.

### Single Return (E = Single Liner, M = Multi Liner)

#### For single-start ball screws

After each turn, the balls are lifted from the shaft raceway and set back by a single turn. Thomson NEFF return systems made from glass-fiber reinforced plastic or steel guarantee a faultless and gentle recirculation of the balls.

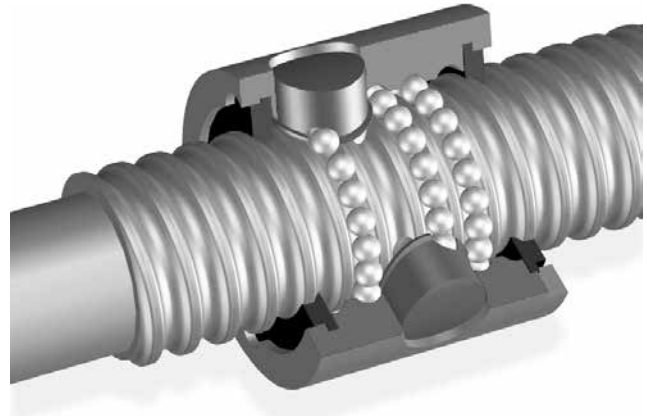

### Internal Return (K = Channel)

#### For single-start and multiple-start ball screws.

After several turns, the balls are returned either by a patented plastic recirculation system integrated into the nut or through recirculation channels also integrated into the nut using steel recirculation inserts.

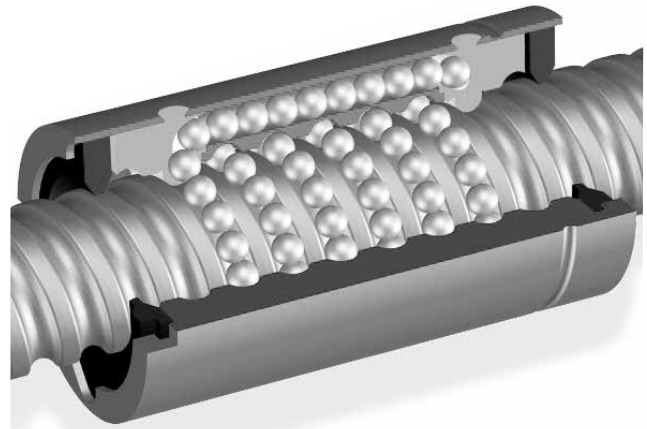

### External Return (D = End Cap)

#### For multiple-start ball screws.

The balls are recirculated via two special end caps and return channels integrated into the nut.

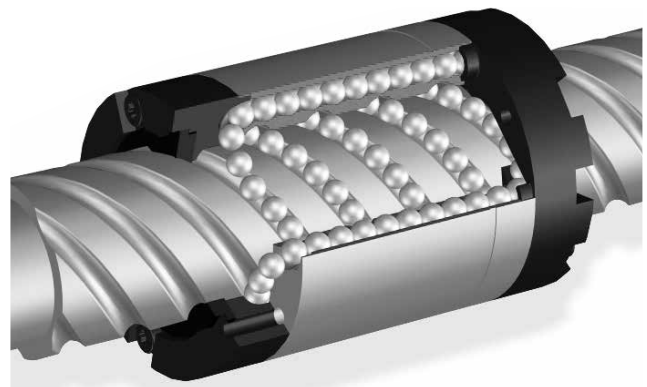

Sold & Serviced By:



Toll Free Phone (877) SERV098

[www.electromate.com](http://www.electromate.com)

[sales@electromate.com](mailto:sales@electromate.com)

# Bearing Supports Product Overview

## Metric Ball Screws

| Diameter | BK      | BF      | FK      | FF      | MK      | WK      |
|----------|---------|---------|---------|---------|---------|---------|
| 12       | 7833391 | 7833398 | 7833405 | 7833411 | 7833700 | -       |
| 16       | 7833392 | 7833399 | 7833406 | 7833412 | 7833701 | -       |
| 20       | 7833393 | 7833400 | 7833407 | 7833413 | 7833702 | -       |
| 25       | 7833394 | 7833401 | 7833408 | 7833414 | 7833703 | 7833614 |
| 32       | 7833395 | 7833402 | 7833409 | 7833415 | -       | 7833615 |
| 40       | 7833396 | 7833403 | 7833410 | 7833416 | -       | 7833617 |
| 50       | 7833397 | 7833404 | -       | -       | -       | 7833621 |



### BK Bearing Support <sup>(1), (2)</sup>

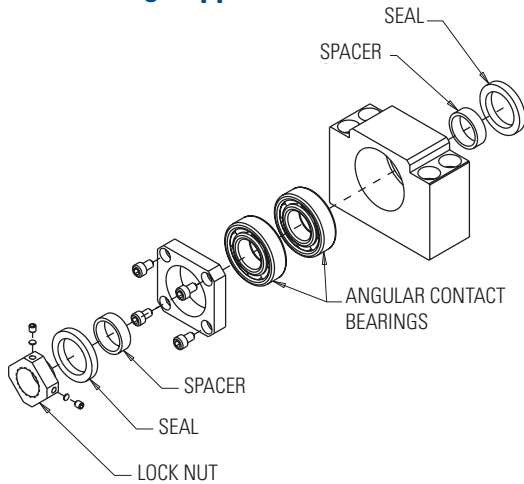

The base mounted BK Bearing Support contains an angular contact bearing pair for increased stiffness and axial load capacity. Design dimensions fit standard Type BK or BK1 end machining.

### FK Bearing Support <sup>(1), (2)</sup>

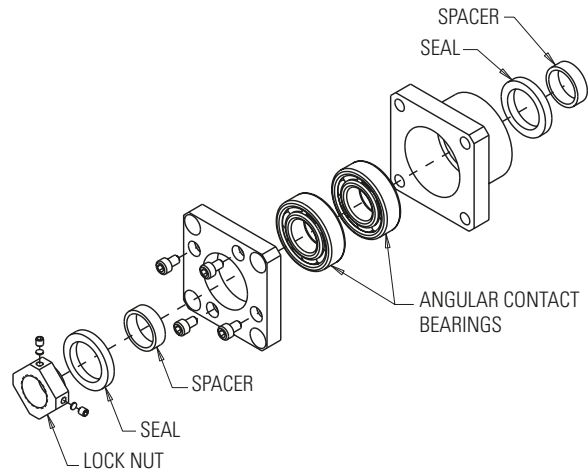

The flange-mounted FK Bearing Support contains an angular contact bearing pair for increased stiffness and axial load capacity. Design dimensions fit standard Type FK or FK1 end machining.

Sold & Serviced By:



Toll Free Phone (877) SERV098

[www.electromate.com](http://www.electromate.com)

[sales@electromate.com](mailto:sales@electromate.com)

### BF Bearing Support <sup>(1),(3)</sup>

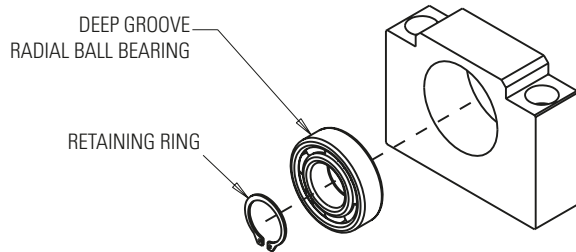

Base-mounted BF Bearing Support contains a floating radial bearing to allow axial shaft movement. Design dimensions fit standard Type BF or BF1 end machining.

### FF Bearing Support <sup>(1),(3)</sup>

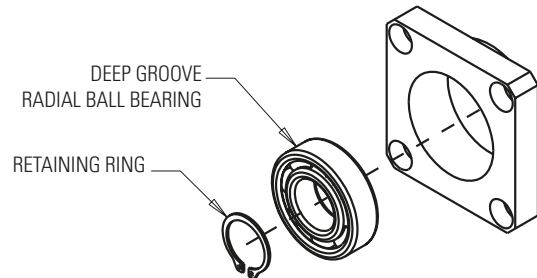

The flange-mounted FF Bearing Support contains a floating radial bearing to allow axial shaft movement. Design dimensions fit standard Type FF or FF1 end machining.

### MK Bearing Support <sup>(2)</sup>

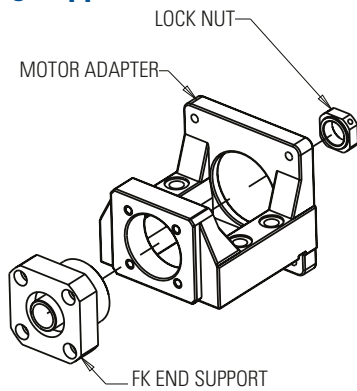

Base-mounted NEMA 23 or 34 motor mount. Design dimensions fit standard Type FK end machining.

### WK Bearing Support <sup>(2)</sup>

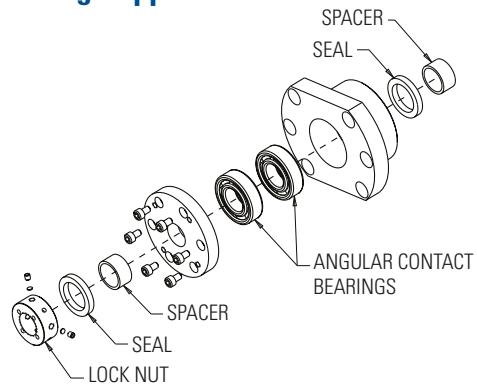

Heavy duty, flange-mounted WK support contains higher load capacity bearings. Design dimensions fit standard WK or WK1 end machining.

(1) BK, FK, MK and WK supports are classified as "fixed," and BF and FF supports are classified as "simple" for purposes of critical speed and column strength calculations.

(2) Locknut included in assembly

(3) Retaining ring included in assembly

Sold & Serviced By:



Toll Free Phone (877) SERV098

[www.electromate.com](http://www.electromate.com)

[sales@electromate.com](mailto:sales@electromate.com)

## Flanged Style Ball Nuts – Technical Specifications



### Standard Lead Accuracy

10-12 mm:  $\pm 52 \mu\text{m} / 300 \text{ mm}$

$\geq 16 \text{ mm}$ :  $\pm 23 \mu\text{m} / 300 \text{ mm}$ <sup>(1)</sup>

Note: Some sizes only available with round flange; check L8 dimension for flange style.

### Internal Return Flanged Ball Nut and Screw

- Flexible solution for standard mounting
- Integral wiper ( $\geq 16 \text{ mm}$ ) and flange included as standard
- Available in three preload classes (Type Z1, Z2, Z3)
  - Z1 – light preload to 1-2% (16 - 50 mm only)
  - Z2 – no preload, clearance held to max indicated in table (standard unless specified)
  - Z3 – no preload, clearance held to max 0.05 mm (16 - 50 mm only)

### Technical Specifications

| Nom. Dia-<br>meter | Lead | Nut<br>Form | Return<br>System | Ball Nut<br>P/N     | Ball<br>Screw<br>P/N | Performance Data         |       |                         |       |                       | Screw Specifications |                   |               |               |                 |
|--------------------|------|-------------|------------------|---------------------|----------------------|--------------------------|-------|-------------------------|-------|-----------------------|----------------------|-------------------|---------------|---------------|-----------------|
|                    |      |             |                  |                     |                      | Dynamic Load<br>Capacity |       | Static Load<br>Capacity |       | Max Axial<br>Backlash | Major<br>Diameter    | Minor<br>Diameter | Std<br>Length | Max<br>Length | Screw<br>Weight |
|                    |      |             |                  |                     |                      | [kN]                     | [lbs] | [kN]                    | [lbs] |                       |                      |                   |               |               |                 |
| 10                 | 2    | M           | M                | <b>8103-448-039</b> | 190-9680             | 2.0                      | 440   | 3.4                     | 769   | 0.05                  | 9.8                  | 8.3               | 1800          | 1800          | 0.59            |
| 10                 | 3    | M           | M                | <b>8103-448-040</b> | 190-9681             | 4.8                      | 1076  | 8.6                     | 1941  | 0.05                  | 9.7                  | 8.0               | 1800          | 1800          | 0.58            |
| 10                 | 10   | M           | K                | <b>8103-448-042</b> | 190-9689             | 2.9                      | 659   | 5.2                     | 1176  | 0.05                  | 9.7                  | 7.9               | 1900          | 1800          | 0.58            |
| 12                 | 2    | M           | M                | <b>8105-448-043</b> | 190-9690             | 6.8                      | 1550  | 13.1                    | 2945  | 0.05                  | 11.8                 | 10.3              | 1800          | 1800          | 0.86            |
| 16                 | 5    | E           | E                | <b>7106-448-061</b> | 195-9698             | 9.3                      | 2091  | 13.1                    | 2945  | 0.08                  | 15.3                 | 12.9              | 4000          | 6000          | 1.30            |
| 16                 | 10   | E           | K                | <b>7106-448-062</b> | 195-9699             | 15.4                     | 3462  | 26.5                    | 5958  | 0.08                  | 15.2                 | 13.0              | 4000          | 6000          | 1.30            |
| 20                 | 5    | E           | K                | <b>7107-448-063</b> | 195-9700             | 10.5                     | 2361  | 16.6                    | 3732  | 0.08                  | 19.3                 | 16.9              | 4000          | 6000          | 2.00            |
| 25                 | 5    | E           | E                | <b>7110-448-064</b> | 195-9701             | 12.3                     | 2765  | 22.5                    | 5058  | 0.08                  | 24.3                 | 21.9              | 4000          | 6000          | 3.30            |
| 25                 | 10   | E           | K                | <b>7110-448-065</b> | 195-9702             | 13.2                     | 2968  | 25.3                    | 5688  | 0.08                  | 24.3                 | 21.9              | 4000          | 6000          | 3.30            |
| 25                 | 20   | S           | D                | <b>7110-448-066</b> | 195-9703             | 13.0                     | 2923  | 23.3                    | 5238  | 0.15                  | 24.4                 | 22.0              | 4000          | 6000          | 3.30            |
| 25                 | 25   | S           | D                | <b>7110-448-067</b> | 195-9704             | 16.7                     | 3754  | 32.2                    | 7239  | 0.08                  | 24.3                 | 22.0              | 4000          | 6000          | 3.30            |
| 32                 | 5    | E           | E                | <b>7112-448-069</b> | 195-9706             | 21.5                     | 4834  | 49.3                    | 11084 | 0.08                  | 31.3                 | 28.9              | 4000          | 6000          | 5.60            |
| 32                 | 10   | E           | E                | <b>7112-448-070</b> | 195-9707             | 33.4                     | 7509  | 54.5                    | 12253 | 0.08                  | 32.5                 | 27.3              | 4000          | 6000          | 5.60            |
| 32                 | 20   | E           | K                | <b>7112-448-071</b> | 195-9708             | 29.7                     | 6677  | 59.8                    | 13444 | 0.08                  | 31.5                 | 27.9              | 4000          | 6000          | 5.60            |
| 40                 | 5    | E           | E                | <b>7115-448-073</b> | 195-9710             | 23.8                     | 5351  | 63.1                    | 14186 | 0.08                  | 39.3                 | 36.9              | 4000          | 6000          | 9.00            |
| 40                 | 10   | E           | E                | <b>7115-448-074</b> | 195-9711             | 38.0                     | 8543  | 69.1                    | 15535 | 0.08                  | 39.3                 | 34.1              | 4000          | 6000          | 8.40            |
| 40                 | 20   | E           | K                | <b>7115-448-075</b> | 195-9712             | 33.3                     | 7487  | 76.1                    | 17109 | 0.08                  | 39.5                 | 35.9              | 4000          | 6000          | 9.00            |
| 40                 | 40   | S           | D                | <b>7115-448-076</b> | 195-9713             | 35.0                     | 7869  | 101.9                   | 22909 | 0.08                  | 38.7                 | 36.3              | 4000          | 6000          | 9.00            |
| 50                 | 10   | E           | E                | <b>7120-448-077</b> | 195-9714             | 68.7                     | 15445 | 155.8                   | 35027 | 0.08                  | 49.3                 | 44.1              | 4000          | 6000          | 13.50           |

(1) P3 accuracy class is  $\pm 12 \mu\text{m} / 300 \text{ mm}$  for nut sizes 16 mm and greater and is available upon request.



# Flanged Style Ball Nuts – Technical Specifications

FORM E

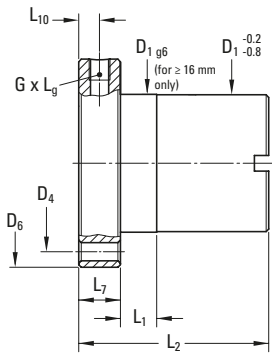

FORM M

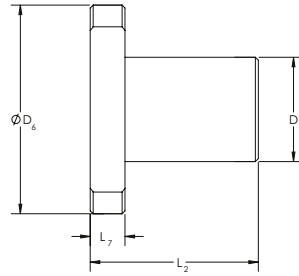

FORM S

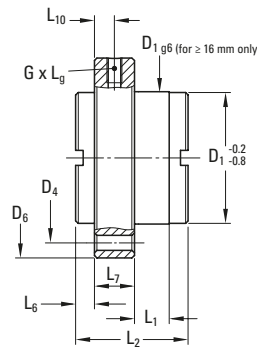

HOLE PATTERN 0 ≤ 12 mm ONLY

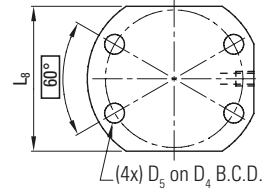

HOLE PATTERN 1  
FLANGED FORM B  
TO DIN 69051

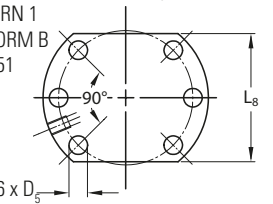

HOLE PATTERN 2  
FLANGED FORM B  
TO DIN 69051

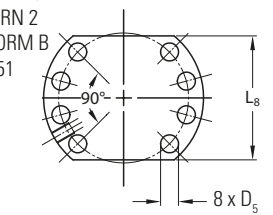

## Technical Specifications

|  | Nom. Diameter | Lead | Hole Pattern | Nut Specifications   |      |      |      |      |      |      |      |                    |      | Lube Hole (G) | No. of Circuits | Ball Diameter |      |
|--|---------------|------|--------------|----------------------|------|------|------|------|------|------|------|--------------------|------|---------------|-----------------|---------------|------|
|  |               |      |              | D1 g6 <sup>(2)</sup> | D4   | D5   | D6   | L1   | L2   | L6   | L7   | L8                 | L10  |               |                 |               |      |
|  | [mm]          | [mm] |              | [mm]                 | [mm] | [mm] | [mm] | [mm] | [mm] | [mm] | [mm] | [mm]               | [mm] | [mm]          |                 |               | [mm] |
|  | 10            | 2    | 0            | 18                   | 28   | 4.5  | 36   | -    | 22   | -    | 6    | 22                 | -    | -             | 5               | 1.588         |      |
|  | 10            | 3    | 0            | 18                   | 28   | 4.5  | 36   | -    | 29   | -    | 6    | 22                 | -    | -             | 7               | 1.984         |      |
|  | 10            | 10   | 0            | 23                   | 30.5 | 4.5  | 38   | -    | 35   | -    | 6    | 24                 | -    | -             | 2 x 1.8         | 1.984         |      |
|  | 12            | 2    | 0            | 20                   | 29   | 4.5  | 37   | -    | 40   | -    | 8    | 24                 | -    | -             | 9               | 1.588         |      |
|  | 16            | 5    | 1            | 28                   | 38   | 6    | 48   | 10   | 42   | -    | 10   | 40                 | 5    | M6x1          | 3               | 3.500         |      |
|  | 16            | 10   | 1            | 28                   | 38   | 6    | 48   | 10   | 55   | -    | 10   | 40                 | 5    | M6x1          | 6               | 3.000         |      |
|  | 20            | 5    | 1            | 36                   | 47   | 7    | 58   | 10   | 42   | -    | 10   | 44                 | 5    | M6x1          | 3               | 3.500         |      |
|  | 25            | 5    | 1            | 40                   | 51   | 7    | 62   | 10   | 42   | -    | 10   | 48                 | 5    | M6x1          | 3               | 3.500         |      |
|  | 25            | 10   | 1            | 40                   | 51   | 7    | 62   | 16   | 55   | -    | 10   | 48                 | 5    | M6x1          | 3               | 3.500         |      |
|  | 25            | 20   | 1            | 40                   | 51   | 7    | 62   | 4    | 35   | 10.5 | 10   | 48                 | 5    | M6x1          | 4               | 3.500         |      |
|  | 25            | 25   | 1            | 40                   | 51   | 7    | 62   | 9    | 35   | 8    | 10   | N/A <sup>(4)</sup> | 5    | M6x1          | 5               | 3.500         |      |
|  | 32            | 5    | 1            | 50                   | 65   | 9    | 80   | 10   | 55   | -    | 12   | 62                 | 6    | M6x1          | 5               | 3.500         |      |
|  | 32            | 10   | 1            | 53 <sup>(3)</sup>    | 65   | 9    | 80   | 16   | 69   | -    | 12   | 62                 | 6    | M8x1          | 3               | 7.140         |      |
|  | 32            | 20   | 1            | 53 <sup>(3)</sup>    | 65   | 9    | 80   | 16   | 80   | -    | 12   | 62                 | 6    | M6x1          | 4               | 5.000         |      |
|  | 40            | 5    | 2            | 63                   | 78   | 9    | 93   | 10   | 57   | -    | 14   | 70                 | 7    | M6x1          | 5               | 3.500         |      |
|  | 40            | 10   | 2            | 63                   | 78   | 9    | 93   | 16   | 71   | -    | 14   | 70                 | 7    | M8x1          | 3               | 7.140         |      |
|  | 40            | 20   | 2            | 63                   | 78   | 9    | 93   | 16   | 80   | -    | 14   | 70                 | 7    | M8x1          | 4               | 5.000         |      |
|  | 40            | 40   | 2            | 63                   | 78   | 9    | 93   | 16   | 85   | 7.5  | 14   | N/A <sup>(4)</sup> | 7    | M8x1          | 8               | 3.500         |      |
|  | 50            | 10   | 2            | 75                   | 93   | 11   | 110  | 16   | 95   | -    | 16   | 85                 | 8    | M8x1          | 5               | 7.140         |      |

(2) For ≥ 16 mm nominal diameter.

(3) Dimension does not comply with DIN 69051.

(4) Round flange.

## Threaded Style Ball Nuts – Technical Specifications



Standard Lead Accuracy:  $\pm 52 \mu\text{m} / 300 \text{ mm}$

### Internal Return Threaded Ball Nut and Screw

- Cost-effective solution in a small envelope, ideal for use in small spaces
- Flexible solution for non-standard mounting
- Available in standard preload classes (Type Z2)
  - Z2 – no preload, clearance held to max indicated in table

### Technical Specifications

| Nom. Diameter | Lead | Return System | Ball Nut P/N        | Ball Screw P/N | Performance Data      |       |                      |       |                     |
|---------------|------|---------------|---------------------|----------------|-----------------------|-------|----------------------|-------|---------------------|
|               |      |               |                     |                | Dynamic Load Capacity |       | Static Load Capacity |       | Max. Axial Backlash |
|               |      |               |                     |                | [kN]                  | [lbs] | [kN]                 | [lbs] |                     |
| 10            | 2    | M             | <b>8103-448-022</b> | 190-9680       | 2.0                   | 440   | 3.4                  | 769   | 0.05                |
| 10            | 3    | M             | <b>8103-448-023</b> | 190-9681       | 4.8                   | 1076  | 8.6                  | 1941  | 0.05                |
| 10            | 10   | K             | <b>8103-448-030</b> | 190-9689       | 2.9                   | 659   | 5.2                  | 1176  | 0.05                |
| 12            | 2    | M             | <b>8105-448-031</b> | 190-9690       | 6.8                   | 1550  | 13.1                 | 2945  | 0.05                |

Sold & Serviced By:



Toll Free Phone (877) SERV098  
[www.electromate.com](http://www.electromate.com)  
[sales@electromate.com](mailto:sales@electromate.com)

## Threaded Style Ball Nuts – Technical Specifications

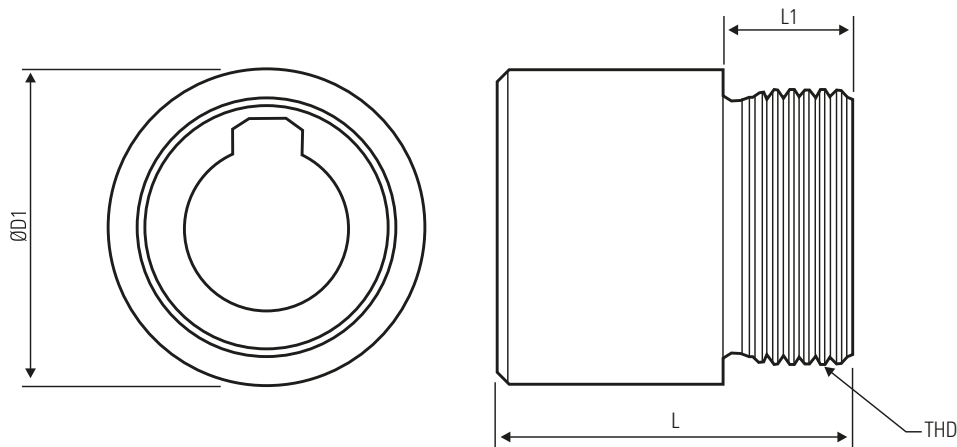

|  | Nom. Diameter | Lead | Screw Specifications |                |            |              | Nut Specifications |         |         |      |                 |               |
|--|---------------|------|----------------------|----------------|------------|--------------|--------------------|---------|---------|------|-----------------|---------------|
|  |               |      | Major Diameter       | Minor Diameter | Std Length | Screw Weight | L                  | D1 0/-1 | THD     | L1   | No. of Circuits | Ball Diameter |
|  | [mm]          | [mm] | [mm]                 | [mm]           | [mm]       | [kg/m]       | [mm]               | [mm]    |         | [mm] |                 | [mm]          |
|  | 10            | 2    | 9.8                  | 8.3            | 1800       | 0.59         | 22                 | 19.5    | M17 x 1 | 8    | 5               | 1.588         |
|  | 10            | 3    | 9.7                  | 8.0            | 1800       | 0.58         | 29                 | 21      | M18 x 1 | 9    | 7               | 1.984         |
|  | 10            | 10   | 9.7                  | 7.9            | 1800       | 0.58         | 35                 | 23      | M18 x 1 | 9    | 2x1.8           | 1.984         |
|  | 12            | 2    | 11.8                 | 10.3           | 1800       | 0.86         | 40                 | 24      | M20 x 1 | 10   | 9               | 1.588         |

Sold & Serviced By:



Toll Free Phone (877) SERV098

[www.electromate.com](http://www.electromate.com)  
[sales@electromate.com](mailto:sales@electromate.com)

## Cylindrical Style Ball Nuts – Technical Specifications



Standard Lead Accuracy:  $\pm 52 \mu\text{m} / 300 \text{ mm}$

### Internal Return Cylindrical Ball Nut and Screw

- Cost-effective solution in a small envelope, ideal for use in small spaces
- Flexible solution for non-standard mounting
- Available in standard preload classes (Type Z2)
  - Z2 – no preload, clearance held to max indicated in table

### Technical Specifications

| Nom. Diameter | Lead | Return System | Ball Nut P/N        | Ball Screw P/N | Performance Data      |       |                      |       |                     |
|---------------|------|---------------|---------------------|----------------|-----------------------|-------|----------------------|-------|---------------------|
|               |      |               |                     |                | Dynamic Load Capacity |       | Static Load Capacity |       | Max. Axial Backlash |
|               |      |               |                     |                | [kN]                  | [lbs] | [kN]                 | [lbs] |                     |
| 10            | 2    | M             | <b>8103-448-052</b> | 190-9680       | 2.0                   | 440   | 3.4                  | 769   | 0.05                |
| 10            | 3    | M             | <b>8103-448-053</b> | 190-9681       | 4.8                   | 1076  | 8.6                  | 1941  | 0.05                |
| 10            | 10   | K             | <b>8103-448-055</b> | 190-9689       | 2.9                   | 659   | 5.2                  | 1176  | 0.05                |
| 12            | 2    | M             | <b>8105-448-056</b> | 190-9690       | 6.8                   | 1550  | 13.1                 | 2945  | 0.05                |

Sold & Serviced By:



Toll Free Phone (877) SERV098  
www.electromate.com  
sales@electromate.com

## Cylindrical Style Ball Nuts – Technical Specifications

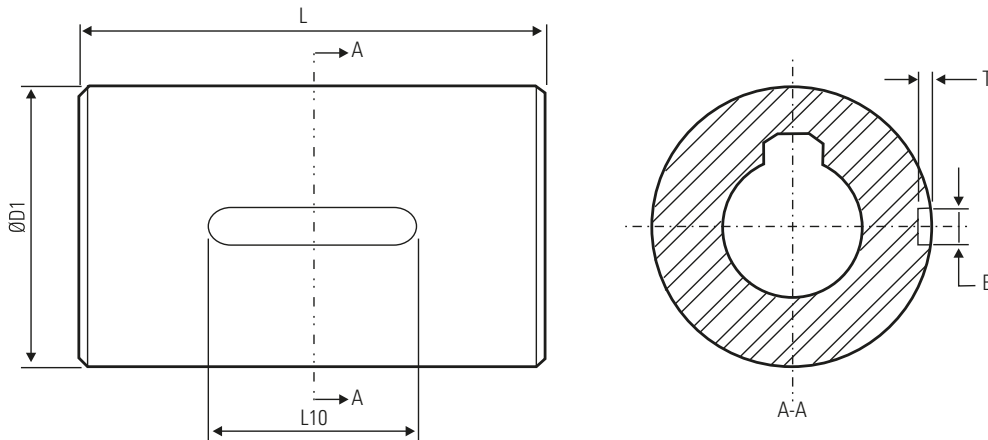

|  | Nom. Diameter | Lead | Screw Specifications |                |            |              | Nut Specifications |       |          |      |                 |               |
|--|---------------|------|----------------------|----------------|------------|--------------|--------------------|-------|----------|------|-----------------|---------------|
|  |               |      | Major Diameter       | Minor Diameter | Std Length | Screw Weight | L                  | D1 g6 | B x T N9 | L10  | No. of Circuits | Ball Diameter |
|  | [mm]          | [mm] | [mm]                 | [mm]           | [mm]       | [kg/m]       | [mm]               | [mm]  |          | [mm] |                 | [mm]          |
|  | 10            | 2    | 9.8                  | 8.3            | 1800       | 0.59         | 22                 | 19.5  | 3 x 1.8  | 13   | 5               | 1.588         |
|  | 10            | 3    | 9.7                  | 8.0            | 1800       | 0.58         | 29                 | 21    | 3 x 1.8  | 13   | 7               | 1.984         |
|  | 10            | 10   | 9.7                  | 7.9            | 1800       | 0.58         | 35                 | 23    | 3 x 1.8  | 13   | 2x1.8           | 1.984         |
|  | 12            | 2    | 11.8                 | 10.3           | 1800       | 0.86         | 40                 | 24    | 3 x 1.8  | 18   | 9               | 1.588         |

Sold & Serviced By:



Toll Free Phone (877) SERV098  
[www.electromate.com](http://www.electromate.com)  
[sales@electromate.com](mailto:sales@electromate.com)

# How to Order Metric Precision Rolled Ball Screws

This ordering key provides a quick overview of available precision rolled metric ball screws. To explore additional technical resources and options, contact Thomson customer support.

| Ordering Key   |   |   |  |     |       |   |    |    |    |    |    |    |
|--|---|---|--|-----|-------|---|----|----|----|----|----|----|
| 1  | 2   | 3   | 4  | 5   | 6     | 7 | 8  | 9  | 10 | 11 | 12 | 13 |
| RM   | 25  | 10  | FD   | Z2- | 271.5 | L | W- | BK | S  | K  | X  |    |
| <b>1. Nut Configuration</b><br>RM = Metric<br><br><b>2. Nominal thread diameter</b><br>10 = 10 mm<br>12 = 12 mm<br>16 = 16 mm<br>20 = 20 mm<br>25 = 25 mm<br>32 = 32 mm<br>40 = 40 mm<br>50 = 50 mm<br>63 = 63 mm<br>80 = 80 mm<br><br><b>3. Thread lead</b><br>02 = 2 mm<br>03 = 3 mm<br>04 = 4 mm<br>05 = 5 mm<br>10 = 10 mm<br>20 = 20 mm<br>25 = 25 mm<br>40 = 40 mm   | <b>4. Nut style</b><br>T = Threaded internal ball return (TSI)<br>R = Cylindrical internal ball return (RSI)<br>FD = Flanged internal ball return (FSI)<br>FK = Flanged (DIN 69051), metal ball return<br>FN = Flanged, polymer ball return<br>MD = Flanged (DIN 69051), polymer ball return<br>MG = Threaded, metal ball return<br><br><b>5. Nut assembly condition</b><br>Z1 = Light preload (1-2%)<br>Z2 = Standard backlash<br>Z3 = Backlash reduced (0.05 mm max.)<br><br><b>6. Threaded length</b><br>xxx.x = Length (mm)<br><br><b>7. Nut orientation</b><br>R = Nut faces right end<br>L = Nut faces left end<br>X = Nut ships on arbor<br><br><b>8. Wipers</b><br>X = No wipers<br>W = Polymer wipers (standard) | <b>9. Left end configuration</b><br>X = Cut to length<br>K = Machine to print with drive<br>BK = Base mount with drive<br>BK1 = Base mount without drive<br>BF = Floating base mount with drive<br>BK1 = Floating base mount without drive<br>FK = Flange mount with drive<br>FK1 = Flange mount without drive<br>FF = Floating flange mount with drive<br>FF1 = Floating flange mount without drive<br>QK = Base mount with drive<br>QK1 = Base mount without drive<br>QF = Floating base mount with drive<br>QK1 = Floating base mount without drive<br>WK = Heavy duty flange with drive<br>WK1 = Heavy duty flange without drive<br>MK = Motor mount with drive<br><br><b>10. Left screw support configuration</b><br>X = No support (machined only)<br>S = Support installed on machined surface | <b>11. Right end configuration</b><br>X = Cut to length<br>K = Machine to print with drive<br>BK = Base mount with drive<br>BK1 = Base mount without drive<br>BF = Floating base mount with drive<br>BK1 = Floating base mount without drive<br>FK = Flange mount with drive<br>FK1 = Flange mount without drive<br>FF = Floating flange mount with drive<br>FF1 = Floating flange mount without drive<br>QK = Base mount with drive<br>QK1 = Base mount without drive<br>QF = Floating base mount with drive<br>QK1 = Floating base mount without drive<br>WK = Heavy duty flange with drive<br>WK1 = Heavy duty flange without drive<br>MK = Motor mount with drive<br><br><b>12. Right screw support configuration</b><br>X = No support (machined only)<br>S = Support installed on machined surface<br><br><b>13. Custom Modifier</b><br>blank = Standard<br>M = Custom |     |       |   |    |    |    |    |    |    |
| <p>Code Example: RM2510FDZ2-271.5LW-BKSKX</p> <p>This describes a standard lashed Ø25 x 10 mm FSI ball screw assembly that is 271.5 mm in threaded length with a BK bearing support on the left side with drive extension, BK end bearing support without drive on the right side. The flange faces the left side (the side with the drive extension).</p> <p>NOTE: Not all bearing supports are available in all sizes. See catalog or contact customer support for available combinations.</p> |   |   |  |     |       |   |    |    |    |    |    |    |

## Express Prototypes, Less Lead Time

Prices and lead times are generally higher with other products as 98% of rolled metric ball screws are manufactured outside of North America.

Thomson provides expert application support and the ability to rapidly prototype designs by combining North American manufacturing of metric products with the engineering support of a trusted brand.

Don't pay extra to wait.

Order your Thomson prototype with delivery from our North American facility in Marengo:

|                     | Standard Lead Time | Express Lead Time (Qualified Prototypes) |
|---------------------|--------------------|--|
| Components          | 2 - 3 days         | 1 day                                    |
| Machined Assemblies | 2 - 4 weeks        | 1 - 2 weeks                              |

Sold & Serviced By:



Toll Free Phone (877) SERV098

www.electromate.com  
sales@electromate.com

## Customized Products and Machining to Fit Your Applications

### Standard (16 - 50 mm) Metric Ball Screws

- Custom coatings available (thin dense chrome)
- $\pm 12 \mu\text{m}/300 \text{ mm}$  lead accuracy (P3)
- Reduced backlash (0.05 mm)

### Miniature Metric Ball Screws

- Custom coatings available (thin dense chrome)

### Standard and custom machining



Precision end journal machining to standard or customer specified requirements using CNC lathe and grinding.

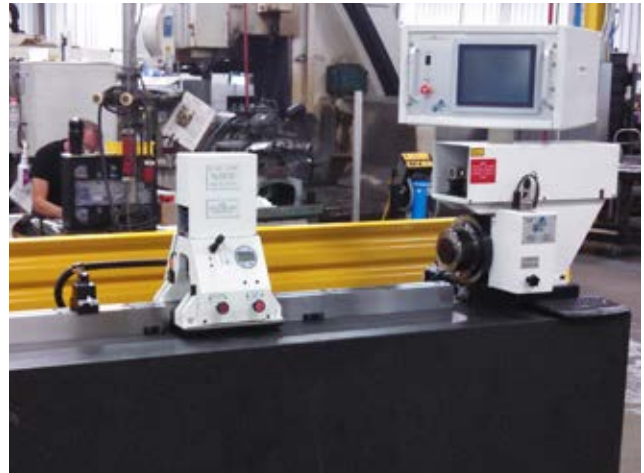

State-of-the-art dynamic lead error verification to P5 accuracy.

Sold & Serviced By:

 **ELECTROMATE**

Toll Free Phone (877) SERV098

[www.electromate.com](http://www.electromate.com)

[sales@electromate.com](mailto:sales@electromate.com)

# Ball Screw Engineering

## Acceptable Speed vs. Length for Screws

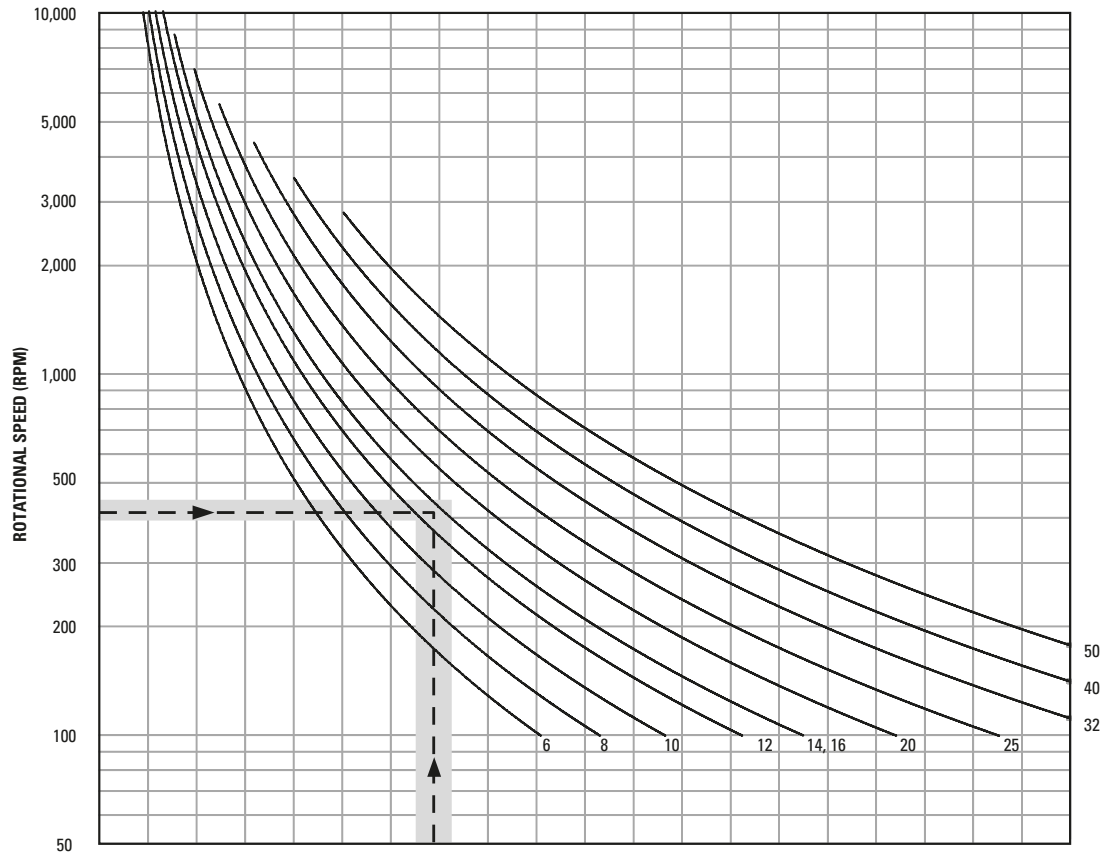

### END SUPPORT TYPE

| Support Type                          | Lead (in) | Lead (mm) | 6   | 12  | 18   | 24   | 30   | 36   | 42   | 48   | 54   | 60   | 66   | 72   | 78   | 84   | 90   | 96   | 102  | 108  | 114  | 120  |
|---------------------------------------|-----------|-----------|-----|-----|------|------|------|------|------|------|------|------|------|------|------|------|------|------|------|------|------|------|
| A: One end fixed, other end free      | Inches    |           | 6   | 12  | 18   | 24   | 30   | 36   | 42   | 48   | 54   | 60   | 66   | 72   | 78   | 84   | 90   | 96   | 102  | 108  | 114  | 120  |
|                                       | mm        |           | 152 | 304 | 457  | 609  | 762  | 914  | 1066 | 1219 | 1371 | 1524 | 1676 | 1828 | 1981 | 2133 | 2286 | 2438 | 2590 | 2743 | 2895 | 3048 |
| B: Both ends supported                | Inches    |           | 10  | 20  | 30   | 40   | 50   | 60   | 70   | 80   | 90   | 100  | 110  | 120  | 130  | 140  | 150  | 160  | 170  | 180  | 190  | 200  |
|                                       | mm        |           | 254 | 508 | 762  | 1016 | 1270 | 1524 | 1778 | 2032 | 2286 | 2540 | 2794 | 3048 | 3302 | 3556 | 3810 | 4064 | 4318 | 4572 | 4826 | 5080 |
| C: One end fixed, other end supported | Inches    |           | 12  | 24  | 36   | 48   | 61   | 73   | 85   | 97   | 109  | 121  | 133  | 145  | 158  | 170  | 182  | 194  | 206  | 218  | 230  | 242  |
|                                       | mm        |           | 304 | 609 | 914  | 1219 | 1549 | 1854 | 2159 | 2463 | 2768 | 3073 | 3378 | 3683 | 4013 | 4318 | 4622 | 4927 | 5232 | 5537 | 5842 | 6146 |
| D: Both ends fixed                    | Inches    |           | 15  | 30  | 45   | 60   | 75   | 90   | 105  | 119  | 134  | 149  | 164  | 179  | 194  | 209  | 224  | 239  | 254  | 269  | 284  | 298  |
|                                       | mm        |           | 381 | 762 | 1143 | 1524 | 1905 | 2286 | 2667 | 3022 | 3403 | 3784 | 4165 | 4546 | 4927 | 5308 | 5689 | 6070 | 6451 | 6832 | 7213 | 7594 |

Sold & Serviced By:



Toll Free Phone (877) SERV098  
www.electromate.com  
sales@electromate.com



# Ball Screw Engineering

## Compression Load vs. Length for Designated Ball Screws

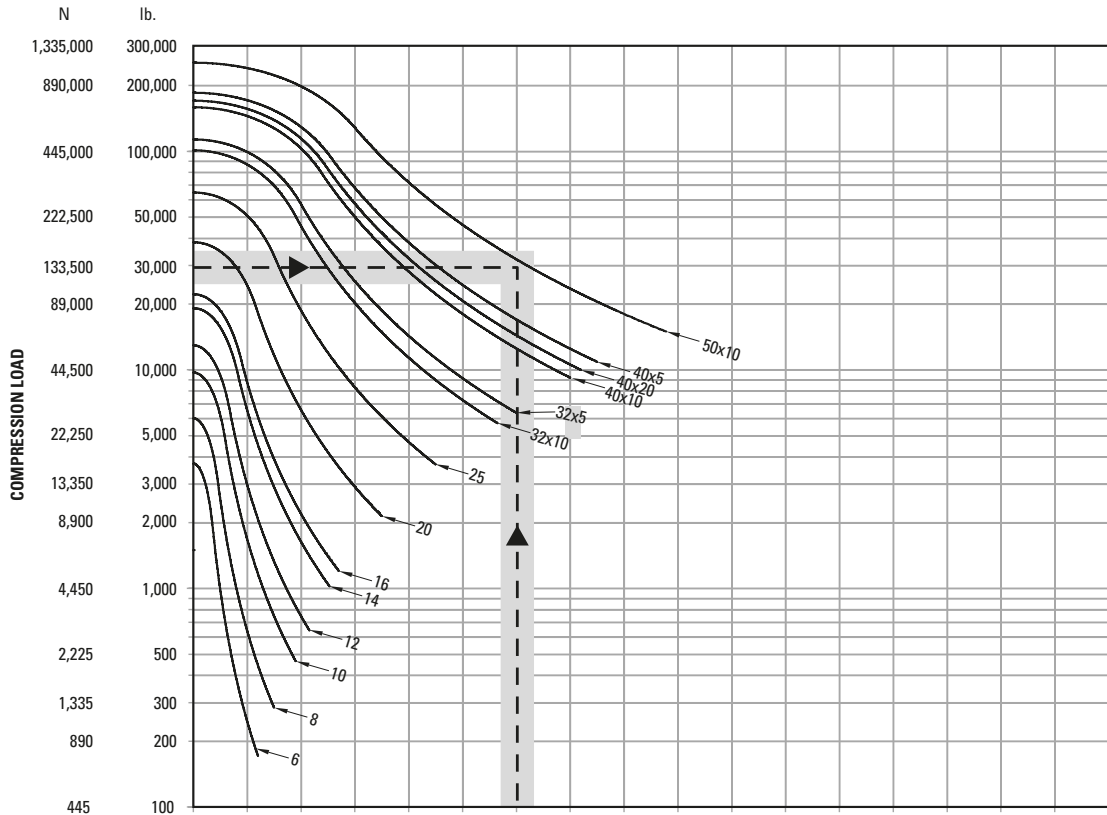

**END SUPPORT TYPE**

| Support Type | Description                        | 5 in | 10 in | 15 in | 20 in | 25 in | 30 in | 35 in | 40 in | 45 in | 50 in | 55 in | 60 in | 65 in | 70 in | 75 in | 80 in | 85 in |
|--------------|------------------------------------|------|-------|-------|-------|-------|-------|-------|-------|-------|-------|-------|-------|-------|-------|-------|-------|-------|
| A            | One end fixed, other end free      | 127  | 254   | 381   | 508   | 635   | 762   | 889   | 1016  | 1143  | 1270  | 1397  | 1524  | 1651  | 1778  | 1905  | 2032  | 2159  |
| B            | Both ends supported                | 254  | 508   | 762   | 1016  | 1270  | 1524  | 1778  | 2032  | 2286  | 2540  | 2794  | 3048  | 3302  | 3556  | 3810  | 4064  | 4318  |
| C            | One end fixed, other end supported | 356  | 711   | 1067  | 1448  | 1803  | 2159  | 2515  | 2870  | 3226  | 3581  | 3962  | 4318  | 4674  | 5029  | 5385  | 5740  | 6096  |
| D            | Both ends fixed                    | 508  | 1016  | 1524  | 2032  | 2540  | 3048  | 3556  | 4064  | 4572  | 5080  | 5588  | 6096  | 6604  | 7112  | 7620  | 8128  | 8636  |

Sold & Serviced By:



Toll Free Phone (877) SERV098  
[www.electromate.com](http://www.electromate.com)  
[sales@electromate.com](mailto:sales@electromate.com)

# Screw Accuracy – Permissible Travel Variation

## Type P – Positioning Ball Screws

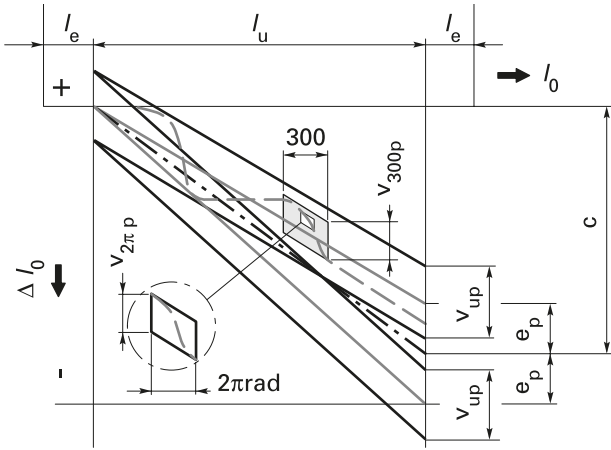

$l_e$  = Axial thread length

$l_u$  = Useful travel

$l_o$  = Overrun = Table 2

## Type T – Transport Ball Screws

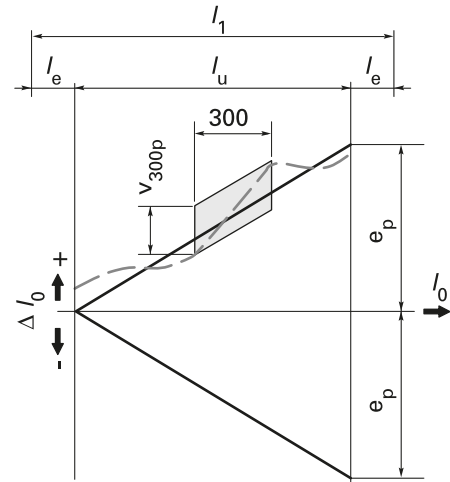

$l_0$  = Nominal distance

$\Delta l_0$  = Travel deviation

### Lead Accuracy

|              |  | P3         | P5      | T7                                   |
|--------------|--|------------|---------|--------------------------------------|
| $v_{300p}$   | Permissible travel variance over 300 mm              | Table 1    | Table 1 | Table 1                              |
| $v_{2\pi p}$ | Permissible travel variance over $2\pi$ travel       | Table 1    | Table 1 | -                                    |
| $c$          | Travel compensation                                  | -0.01/1000 | 0       | 0                                    |
| $e_p$        | Limit deviations for useful distance $l_u$           | Table 3    | Table 3 | $\pm \frac{l_u}{300} \cdot v_{300p}$ |
| $v_{up}$     | Permissible travel variance over useful travel $l_u$ | Table 3    | Table 3 | -                                    |

Table 1

|                   | Tolerance Class |    |    |    |    |
|-------------------|-----------------|----|----|----|----|
|                   | 1               | 3  | 4  | 5  | 7  |
| $v_{300p}$ [μm]   | 6               | 12 | 18 | 23 | 52 |
| $v_{2\pi p}$ [μm] | 4               | 6  | 7  | 8  | -  |

Table 2

|              | Ph [mm] | Tolerance Class |     |      |      |      |
|--------------|---------|-----------------|-----|------|------|------|
|              |         | ≤ 2.5           | ≤ 5 | ≤ 10 | ≤ 20 | > 20 |
| Nominal lead |         |                 |     |      |      |      |
| Lead error   | le [mm] | 10              | 20  | 40   | 60   | 100  |

Table 3

| Tolerance class | $l_u$ [mm] | [μm] | Tolerance Class |     |     |     |     |     |      |      |      |      |      |      |      |      |      |      |       |       |       |
|-----------------|------------|------|-----------------|-----|-----|-----|-----|-----|------|------|------|------|------|------|------|------|------|------|-------|-------|-------|
|                 |            |      | > 0             | 315 | 400 | 500 | 630 | 800 | 1000 | 1250 | 1600 | 2000 | 2500 | 3150 | 4000 | 5000 | 6300 | 8000 | 10000 | 12500 | 16000 |
| 1               | $e_p$      | 6    | 7               | 8   | 9   | 10  | 11  | 13  | 15   | 18   | 22   | 26   | 32   | 39   | 48   | 60   | 76   | 94   | 115   |       |       |
|                 |            |      | $v_{up}$        | 6   | 6   | 7   | 7   | 8   | 9    | 10   | 11   | 13   | 15   | 17   | 21   | 27   | 33   | 40   | 50    | 61    | 76    |
| 3               | $e_p$      | 12   | 13              | 15  | 16  | 18  | 21  | 24  | 29   | 35   | 41   | 50   | 62   | 76   | 92   | 115  | 140  | 175  | 220   |       |       |
|                 |            |      | $v_{up}$        | 12  | 12  | 13  | 14  | 16  | 17   | 19   | 22   | 25   | 29   | 34   | 41   | 49   | 61   | 75   | 92    | 113   | 140   |
| 4               | $e_p$      | 18   | 18              | 20  | 22  | 25  | 28  | 33  | 39   | 46   | 55   | 68   | 84   | 102  | 125  | 159  | 199  | 240  | 290   |       |       |
|                 |            |      | $v_{up}$        | 18  | 19  | 20  | 21  | 23  | 26   | 29   | 33   | 38   | 44   | 52   | 56   | 68   | 83   | 101  | 124   | 152   | 189   |
| 5               | $e_p$      | 23   | 25              | 27  | 32  | 36  | 40  | 47  | 55   | 65   | 78   | 96   | 115  | 140  | 170  | 210  | 270  | 330  | 410   |       |       |
|                 |            |      | $v_{up}$        | 23  | 25  | 26  | 29  | 31  | 34   | 39   | 44   | 51   | 59   | 69   | 82   | 99   | 119  | 142  | 174   | 213   | 265   |

# Glossary and Formulas

## Accuracy

A measurement of precision. Perfect accuracy, for example, means advancing a ball nut 25 mm from any point on a screw will always require the exact same number of revolutions.

## Axial Lash / Backlash

The axial-free motion between the ball nut and ball screw; a measure of system stiffness and repeatability.

## Column Load / Compression Load

Load that would tend to compress or buckle the ball screw shaft.

## Dynamic Load Rating

Maximum load that a ball bearing screw assembly can maintain for 1 million revolutions (Metric Series).

## Lead

The axial distance a screw travels during one revolution.

## Lead Error

The amount of positional error per 300 mm (Metric Series) that is inherent in linear motion on ball screws.

## Load/Life Rating

The usable life of a ball bearing screw assembly measured in revolutions under a specific load. The revolutions that 90% of a group of ball bearing screws will complete, or exceed, before the first evidence of fatigue develops.

## Repeatability

A measure of constancy that is directly related to axial backlash. Higher backlash equates to lower repeatability and may be corrected by preloading the ball nut if required.

## Static Load

Static load is the maximum non-operating load capacity above which brinelling of the ball track occurs.

## Formulas

|                  |   |                              |  |
|------------------|---|------------------------------|--|
| Equivalent Load  | $F_{eq} [N] = \left( \sum_{i=1}^n F_i^3 \times \frac{n_i}{n_{eq}} \times \frac{q_i}{100} \right)^{1/3}$ | Power                        | $P_d [W] = \frac{F_{eq} \times P \times n}{5.398 \times 10^4}$                             |
| Equivalent Speed | $n_{eq} [rpm] = \sum_{i=1}^n n_i \times \frac{q_i}{100}$  | Critical Screw Speed         | $n_s [rpm] = S \times C_{S_1} \times 1.2 \times 10^8 \times \frac{d_r}{L^2}$               |
| Life             | $L_{10} [Rot] = \left( \frac{C_{am}}{F_{eq}} \right)^3 \times 10^6$                                     | Critical Nut Speed           | $DN = d_0 n < 140,000$   |
| Torque           | $T [Nm] = 1.77 \times 10^{-4} \times F_{eq} \times P$   | Permissible Compression Load | $F_s [N] = S \times C_{S_2} \times \frac{9.687}{L^2} \times 10^4 \times \frac{d_r^4}{L^2}$ |

q = Duration [%]

$C_{am}$  = Dynamic Load [N]

P = Lead [mm]

$C_s$  = End Fixity Factor (see table on the right)

S = Safety Factor (0.8 recommended)

$d_0$  = Nominal Diameter [mm]

$d_r$  = Root Diameter [mm]

L = Max. Unsupported Length [mm]

n = Rotational Speed of Screw [RPM]

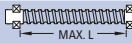
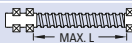
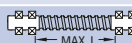
| End Support  | $C_{S_1}$ | $C_{S_2}$ |
|--|-----------|-----------|
| A  | 0.36      | 0.25      |
| B  | 1.00      | 1.00      |
| C  | 1.47      | 2.00      |
| D  | 2.23      | 4.00      |

Sold & Serviced By:



Toll Free Phone (877) SERV098

[www.electromate.com](http://www.electromate.com)

[sales@electromate.com](mailto:sales@electromate.com)



Thomson Marengo, IL USA