



 **THOMSON BSA™**

Thomson BSA Lead and Ball Screws

 **DANAHER
MOTION**

 **ELECTROMATE**
Toll Free Phone (877) SERV098
Toll Free Fax (877) SERV099
www.electromate.com
sales@electromate.com

Table of Contents

| | |
|--|----|
| APPLICATIONS | 1 |
| SUPERNUTS & LEAD SCREWS | 7 |
| BALL SCREWS | 29 |
| COMPLETE SCREW ASSEMBLIES | 51 |
| STOCK STAGES | 61 |
| RAILS & BEARINGS | 67 |
| LINEAR ACTUATORS | 73 |
| ACCESSORIES | 77 |
| GLOSSARY/TECHNICAL INFORMATION | 85 |

**Dimensions listed in catalog are for reference only and are subject to change without notice.*

Applications Data Information Sheet

Name: _____

Title/Dept. _____

Company Name: _____

Address: _____

Phone: _____ Fax: _____

Rep? _____

1. What is your LOAD? _____ Pounds Kilograms Newtons
 Other _____
(please describe)

2. Is your MOTION Horizontal or Vertical

3. What is the length of STROKE? _____ Inch Foot mm
 Other _____
(please describe)

4. What is the SPEED? _____ Inch Foot mm per second minute
 Other _____
(please describe)

5. ACCURACY requirements: 0.005"/foot 0.0005"/foot
 0.003"/foot Other _____
(please describe)

6. BACKLASH requirements: 0" .010"
 0.002" Other _____
(please describe)

7. BEARING SUPPORT requirements: Fixed/Simple Fixed Free
 Fixed/Fixed Other _____
(please describe)

8. MOTOR CUBE requirements NEMA 17 NEMA 42
 NEMA 23 Other _____
 NEMA 34 (please describe)

9. Quantity required _____ per Month Year Other

Additional information/comments:

Applications

| | |
|--------------------------------|---|
| Application #1— | |
| Custom Plastic Nuts | 2 |
| Application #2— | |
| Custom Actuators | 3 |
| Application #3— | |
| Precision Screw Products..... | 4 |
| Application #4— | |
| Components and Assemblies..... | 5 |

Application #1

Custom Plastic Nuts

If cost or design constraints dictate a more integrated package, let our engineering staff help you simplify your design. We offer a full range of manufacturing capabilities from injection molding to CNC machining with the largest selection of engineering plastics to suit your application and specifications.

- Our engineering staff will ensure your part is right the first time.
- Full range of engineering plastics including internally lubricated and high temperature thermoplastics.

Complete assembly selection shown on pages 51 – 60.

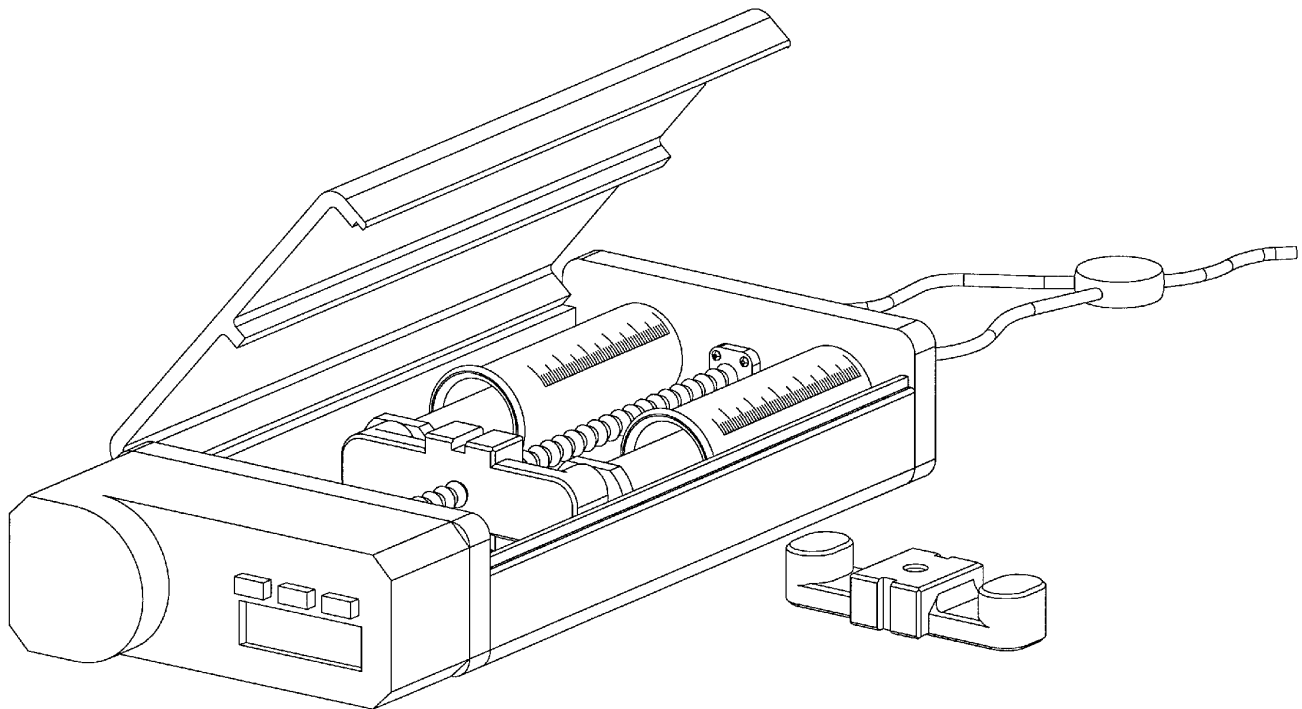

Application #2

Custom Actuators

If your design criteria does not match our large selection of stock assemblies, let Ball Screws and Actuators' Design Engineering Staff discuss your requirements. From simple custom adapters for our stock products to complete high precision tables, our engineering, manufacturing and quality departments offer a comprehensive solution to your custom linear motion needs.

- Design engineering staff
- World class machine shop
- Quality control for verifiable quality assurance

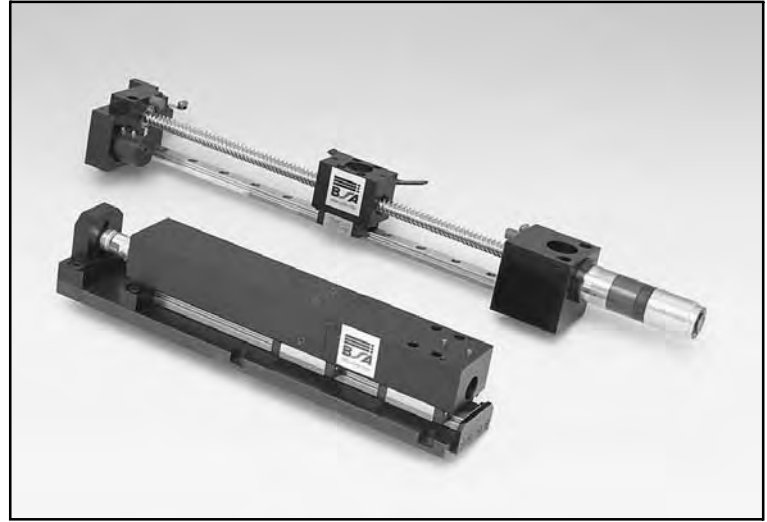

*Complete assembly selection
shown on pages 51 – 60.*

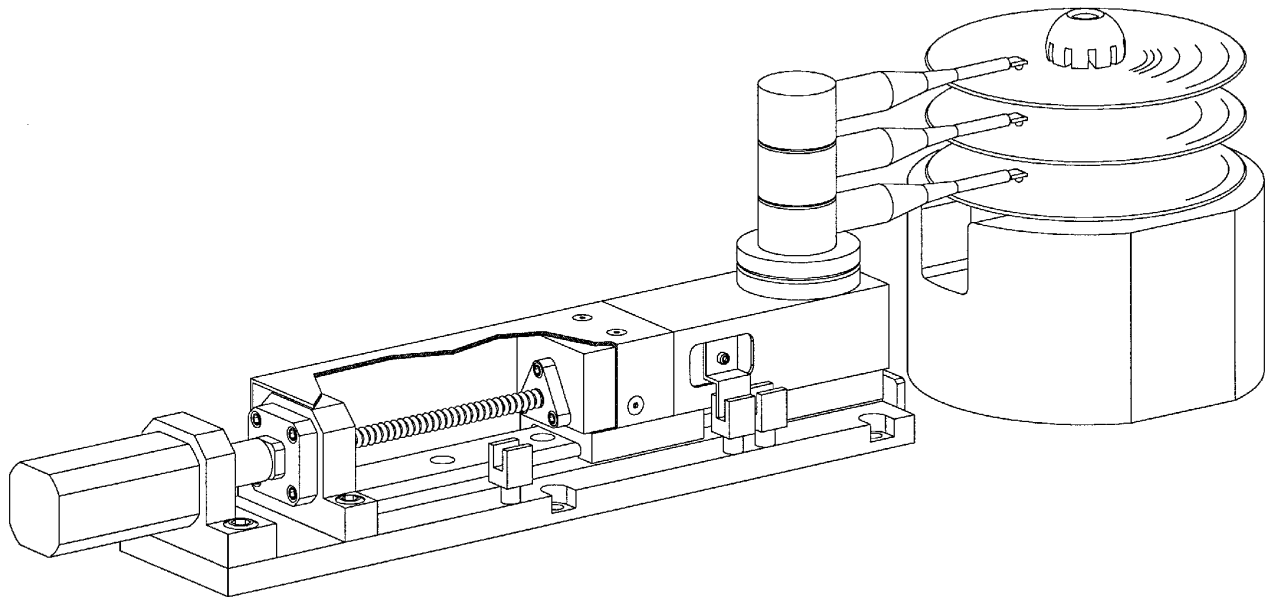

Application #3

Precision Screw Products

Ball Screws and Actuators provides engineering support and quality assurance for all of its components and assemblies allowing our customers to focus on the larger design picture. Our full range of designs and sizes for our linear motion components allow greater design flexibility, while our support staff ensures proper initial application and comprehensive support once installed.

*Complete assembly selection
shown on pages 51 – 60.*

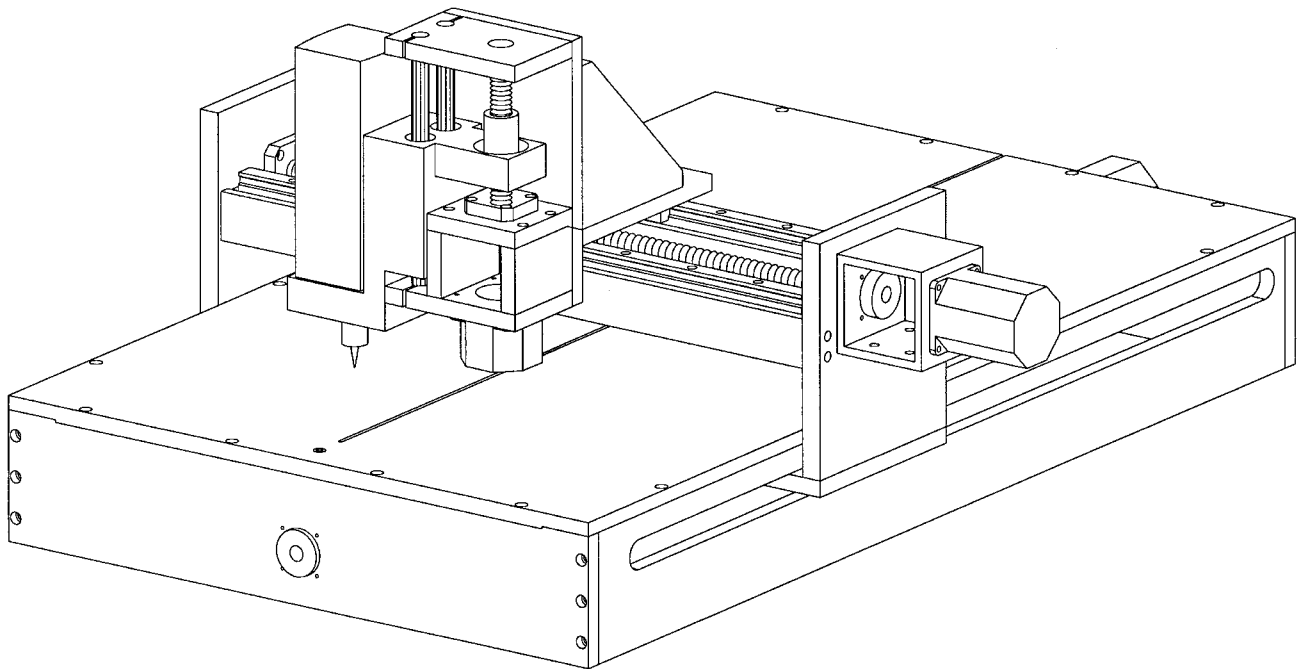

Application #4

Components and Assemblies

From components to complete assemblies, Ball Screws and Actuators always provides the highest performance products for your applications. Let us assist in your design to ensure proper operation of our components, or let us provide you a complete solution.

- Complete solutions to your linear motion designs with our industry tested assemblies.
- Full complement of linear motion components: Rails (square and round), Motor Mounts, Bearing Mounts, Ball Nuts, Acme Plastic Nuts, Bronze Nuts, Anti-Backlash Nuts, Miniature Ball Nuts, Bearings, and more.



*Complete assembly selection
shown on pages 51 – 60.*

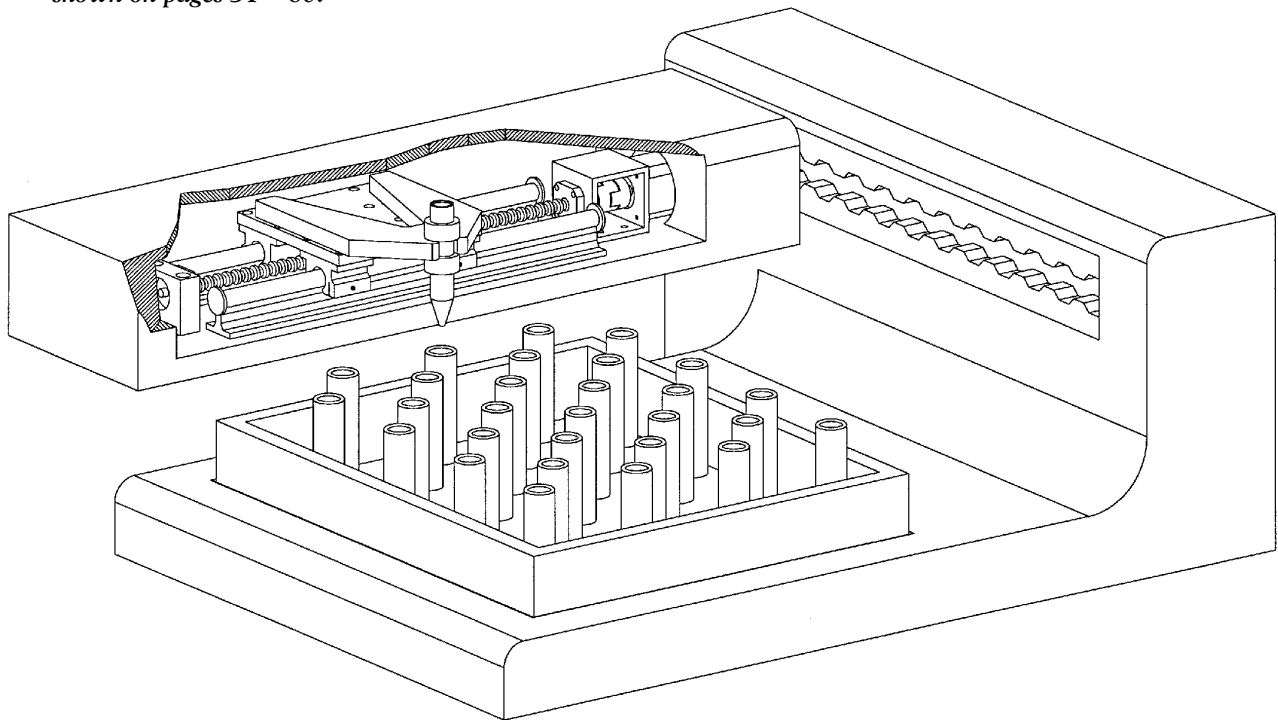

Supernuts™ & Lead Screws

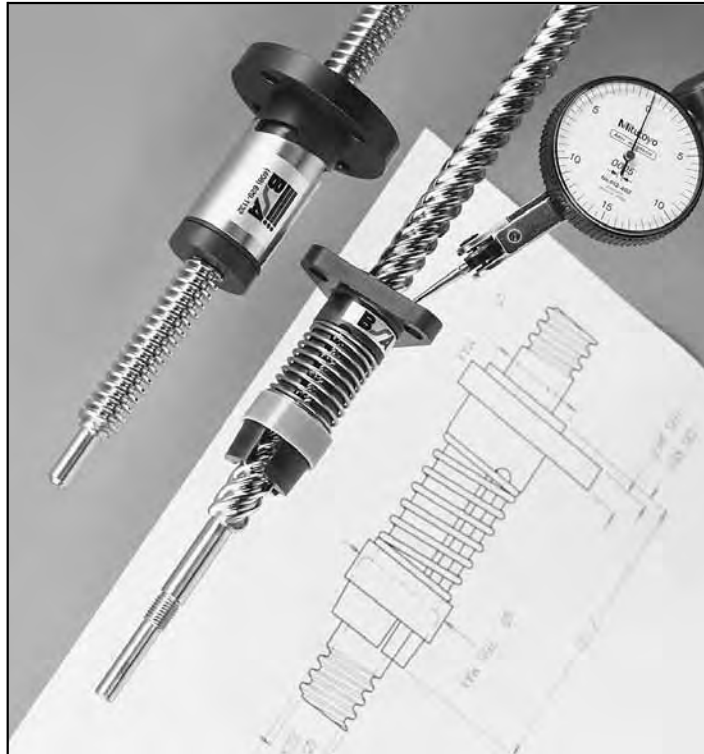

| | |
|---|----|
| Overview | 8 |
| Advanced Anti-Backlash Supernuts™ | 10 |
| Anti-Backlash Supernuts™ | 18 |
| Flange Mount Supernuts™ | 20 |
| Thread Mount Supernuts™ | 22 |
| Bronze Nuts | 24 |
| Lead Screws | 26 |
| VEE Thread Screws | 28 |

Overview

Precision Lead Screws & Supernuts™



Rolled Acme lead screws are an excellent economical solution for your linear motion requirements. For over 15 years Ball Screws and Actuators has manufactured the highest quality lead screw assemblies. Our precision rolling machines ensure accurate positioning to 0.003 in/ft and our PTFE coating process produces assemblies that have less drag torque and last longer.

Ball Screws and Actuators provides a large array of standard plastic nut assemblies in anti-backlash or standard Supernut™ designs. For significantly higher loads, standard bronze nuts are available. BSA also provides engineering design services to aid in your custom design requirements producing a lead—screw assembly to your specifications.

With the introduction of our new unique patent pending Zero-Backlash designs, BSA provides assemblies with high axial stiffness, zero backlash and the absolute minimum drag torque to reduce motor requirements. These designs produce products that cost less, perform better and last longer. Both automatically adjust for wear insuring zero backlash for the life of the nut.

Our large selection of standard plastic nut assemblies all use an internally lubricated Acetal providing excellent lubricity and wear resistance with or without lubrication. For bronze nuts, BSA uses SAE 660 bearing bronze which provides high load capacity with good PV performance.

BSA offers end machining to your specification or can provide you with stock bearing mount, motor mount or complete stage assemblies as shown on pages 51 – 60.

Precision Lead Screws & Supernuts™

Features/Advantages

LOW COST

Considerable savings when compared to ball screw assemblies.

VARIETY

Largest range of leads and diameters 3/16" to 4" to match your requirements.

LUBRICATION

Internally lubricated plastic nuts will operate without lubrication. However, additional lubrication or PTFE coating of the screw is recommended. See page 80.

VIBRATION AND NOISE

No ball recirculating vibration and often less audible noise compared to ball screws.

Design Considerations

LOAD

Supernuts provide a cost effective solution for moderate to light loads. For vertical applications, anti backlash supernuts should be mounted with thread/flange on the bottom.

CANTILEVERED LOADS

Cantilevered loads that might cause a moment on the nut will cause premature failure. Refer to Precision Linear Rails for our complete line-up of linear guides or our stage selection on pages 61 – 72 for a complete linear motion solution.

COLUMN LOADING

Refer to column loading chart on page 87.

CRITICAL SPEED

Refer to critical speed chart on page 86.

SELF-LOCKING

Lead screws can be self locking at low leads. Generally, the lead of the screw should be more than 1/3 of the diameter to satisfactorily backdrive.

CUSTOM

Option of custom designs to fit into your design envelope.

NON-CORROSIVE*

Stainless Steel and internally lubricated Acetal.

ENVIRONMENT

Less susceptible to particulate contamination compared to ball screws.

LIGHTWEIGHT

Less mass to move.

TEMPERATURE

Ambient and friction generated heat are the primary causes of premature plastic nut failure. Observe the temperature limits below and discuss your design with our application engineers for continuous duty, high load and high speed applications. BSA recommends bronze nuts for very high temperature environments or can aid in your selection of high temperature plastic for a custom assembly.

EFFICIENCY

Except at very high leads, efficiency increases as lead increases. Although the internally lubricated Acetal provides excellent lubricity, Ball Screw Assemblies remain significantly more efficient than any Acme design.

LENGTH LIMITATIONS

| | |
|---------------|-----|
| 3/16" to 1/4" | 3' |
| 5/16" to 10mm | 4' |
| 7/16" to 5/8" | 6' |
| > 5/8" | 12' |

LEAD ACCURACY

| | |
|-----------------------|------------|
| Standard Grade (SRA) | .010 in/ft |
| Precision Grade (SPR) | .003 in/ft |

Material Properties

| ASSEMBLY | | SCREWS | NUTS** | | | |
|---------------------|----------------------|------------------|------------------|------------------|-----------------------------|---------------------------------|
| MAXIMUM TEMPERATURE | FRICTION COEFFICIENT | MATERIAL | MATERIAL | TENSILE STRENGTH | WATER ABSORPTION (24 HRS %) | THERMAL EXPANSION COEFFICIENT |
| 180°F | 0.08–0.14 | Stainless Steel* | Acetal with PTFE | 8,000 psi | 0.15 | 5.4 x 10 ⁻⁵ in/in/°F |

*Other materials available on a custom basis.

**Plastic nuts only. See bronze nut section for information on our bronze nut products, page 24.

Advanced Anti-Backlash Supernuts™

XCM 1800

Introducing our smallest anti-backlash nut design ever. The XCM 1800 uses the same patented ActiveCAM™ mechanism as its larger siblings in a miniaturized package. This allows backlash free operation in space critical applications requiring high accuracy and low drag torque. This cost effective solution is available in either flanged or threaded versions.

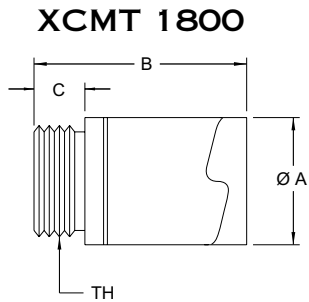

Note: See Screw Section on page 26 for more information. Specify XCMT or XCMF when ordering, see drawings at right.

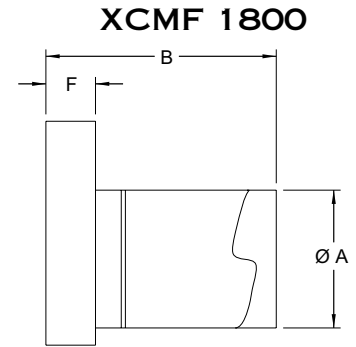
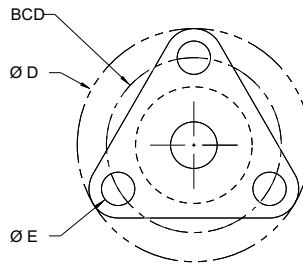

| DIA. | LEAD | PART NO. | SUPERNUT DIMENSIONS | | | | | | | | DESIGN LOAD | EFFICIENCY % | DRAG TORQUE OZ-IN |
|--------|--------|------------|---------------------|---------|-------|------|-------|------|-------|---------|-------------|--------------|-------------------|
| | | | A | B | C | D | E | F | BCD | TH | | | |
| 3/16" | 0.050 | XCM_1820 | 0.50 | .90 max | 0.200 | 1.00 | 0.143 | 0.18 | 0.750 | 7/16-20 | 5 lbs | 49 | < 1 |
| 6 mm* | 1 mm | XCM_6x1 | | | | | | | | | | 29 | |
| 1/4" * | 0.0125 | XCM_2580 | | | | | | | | | | 13 | |
| | 0.0208 | XCM_2548 | | | | | | | | | | 20 | |
| | 0.0250 | XCM_2540 | | | | | | | | | | 23 | |
| | 0.0278 | XCM_2536 | | | | | | | | | | 25 | |
| | 0.0313 | XCM_2532 | | | | | | | | | | 28 | |
| | 0.0357 | XCM_2528 | | | | | | | | | | 30 | |
| | 0.0417 | XCM_2524 | | | | | | | | | | 34 | |
| 1/4" | 0.050 | XCM_2520 | | | | | | | | | | 41 | |
| | 0.063 | XCM_2516 | | | | | | | | | | 48 | |
| | 0.250 | XCM_4-2516 | | | | | | | | | | 76 | |
| | 0.500 | XCM_7-2514 | | | | | | | | | | 81 | |

* Vee-thread screws, see page 28.

† Patent No. 5839321

Advanced Anti-Backlash Supernuts™

XC 2500

The Cross Cam or XC Model Anti-Backlash assembly is Ball Screws and Actuators' most advanced Anti-Backlash nut design. The unique Patented† ActiveCAM™ accomplishes high axial stiffness, zero backlash and the absolute minimum drag torque. This advantage produces assemblies that cost less, perform better and last longer. The ActiveCAM™ automatically adjusts for wear insuring zero backlash for the life of the nut.

Note: See Screw Section on page 26 for more information. Specify XCT or XCF when ordering, see drawings at right.

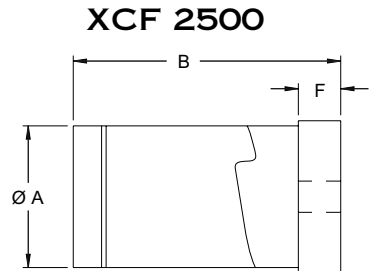
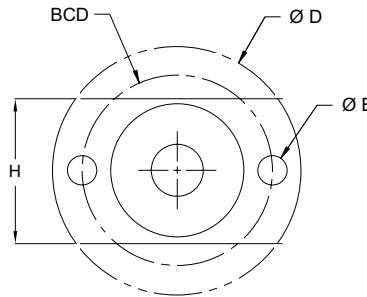
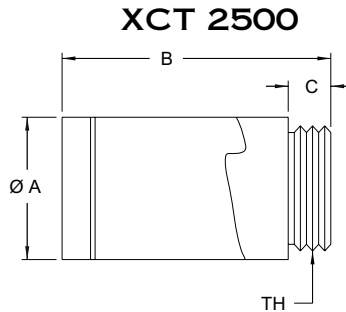

| DIA. | LEAD | PART NO. | SUPERNUT DIMENSIONS | | | | | | | | | DESIGN LOAD | EFFICIENCY % | DRAG TORQUE OZ-IN |
|--------|--------|-----------|---------------------|----------|-------|------|-------|------|------|-------|---------|-------------|--------------|-------------------|
| | | | A | B | C | D | E | F | H | BCD | TH | | | |
| 3/16" | 0.050 | XC_1820 | 0.64 | 1.18 max | 0.187 | 1.19 | 0.141 | 0.16 | 0.66 | 0.900 | 9/16-18 | 10 lbs | 49 | < 1 |
| 6 mm* | 1 mm | XC_6x1 | | | | | | | | | | | 29 | |
| 1/4" * | 0.0125 | XC_2580 | | | | | | | | | | | 13 | |
| | 0.0208 | XC_2548 | | | | | | | | | | | 20 | |
| | 0.0250 | XC_2540 | | | | | | | | | | | 23 | |
| | 0.0278 | XC_2536 | | | | | | | | | | | 25 | |
| | 0.0313 | XC_2532 | | | | | | | | | | | 28 | |
| | 0.0357 | XC_2528 | | | | | | | | | | | 30 | |
| 1/4" | 0.0417 | XC_2524 | | | | | | | | | | | 34 | |
| | 0.050 | XC_2520 | | | | | | | | | | | 41 | |
| | 0.063 | XC_2516 | | | | | | | | | | | 48 | |
| | 0.250 | XC_4-2516 | | | | | | | | | | | 76 | |
| | 0.500 | XC_7-2514 | | | | | | | | | | | 81 | |

* Vee-thread screws, see page 28.

† Patent No. 5839321

Advanced Anti-Backlash Supernuts™

XC 3700

The Cross Cam or XC Model Anti-Backlash assembly is Ball Screws and Actuators' most advanced Anti-Backlash nut design. The unique Patented† ActiveCAM™ accomplishes high axial stiffness, zero backlash and the absolute minimum drag torque. This advantage produces assemblies that cost less, perform better and last longer. The ActiveCAM™ automatically adjusts for wear insuring zero backlash for the life of the nut.

Note: See Screw Section on page 26 for more information. Specify either XCT or XCF when ordering, see drawings at right.

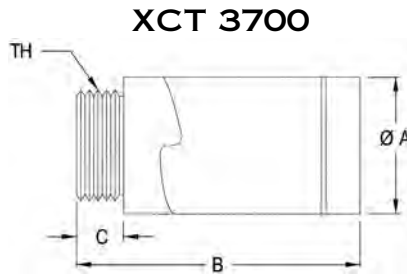

XCF 3700

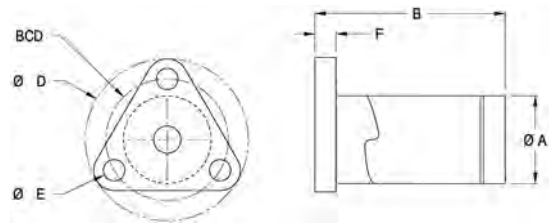

| DIA. | LEAD | PART NO. | SUPERNUT DIMENSIONS | | | | | | | | DESIGN LOAD | EFFICIENCY % | DRAG TORQUE OZ-IN |
|-------|-------|--------------|---------------------|-------------|------|-----|-----|-----|----------|-------|-------------|--------------|-------------------|
| | | | A | B | C | D | E | F | TH | BCD | | | |
| 5/16" | 0.083 | XC_3112 | 0.82 | 1.875 (max) | 0.25 | 1.5 | 0.2 | 0.2 | 5/8" -18 | 1.125 | 25 lbs | 49 | 1 - 3 |
| | 0.167 | XC_2-3112 | | | | | | | | | | 65 | |
| | 0.250 | XC_2-3108 | | | | | | | | | | 72 | |
| | 0.500 | XC_4-3108 | | | | | | | | | | 80 | |
| 3/8" | 0.063 | XC_3716 | | | | | | | | | | 36 | |
| | 2mm | XC_37x2M | | | | | | | | | | 42 | |
| | 0.083 | XC_3712 | | | | | | | | | | 44 | |
| | 0.100 | XC_3710 | | | | | | | | | | 49 | |
| | 0.125 | XC_3708 | | | | | | | | | | 53 | |
| | 0.167 | XC_2-3712 | | | | | | | | | | 60 | |
| | 0.200 | XC_2-3710 | | | | | | | | | | 65 | |
| | 0.250 | XC_2-3708 | | | | | | | | | | 68 | |
| | 0.375 | XC_4-3711 | | | | | | | | | | 75 | |
| 10 mm | 0.500 | XC_4-3708 | | | | | | | | | | 79 | |
| | 2mm | XC_10x2M | | | | | | | | | | 41 | |
| | 3mm | XC_10x3M | | | | | | | | | | 53 | |
| | 6mm | XC_4-10x1.5M | 67 | | | | | | | | | | |
| | 20mm | XC_6-10x3.3M | 81 | | | | | | | | | | |

† Patent No. 5839321

Advanced Anti-Backlash Supernuts™

XC 5000

The XC 5000 utilizes the same Patented† ActiveCAM™ as found in the XC 3700 model. Along with the very low drag torque and high axial stiffness advantages, the XC 5000 has greater load capacity.

Note: See Screw Section on page 26 for more information. Specify either XCT or XCF when ordering, see drawings at right.

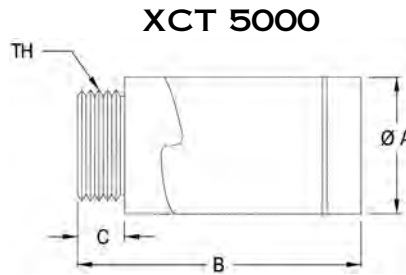

XCF 5000

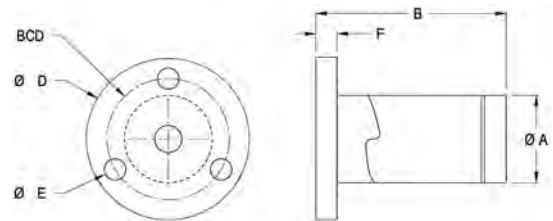

| DIA. | LEAD | PART NO. | SUPERNUT DIMENSIONS | | | | | | | | DESIGN LOAD | EFFICIENCY % | DRAG TORQUE OZ-IN |
|-------|-------|--------------|---------------------|------------|-------|------|-----|-----|----------|-------|-------------|--------------|-------------------|
| | | | A | B | C | D | E | F | TH | BCD | | | |
| 7/16" | 0.125 | XC_2-4316 | 1.12 | 2.25 (max) | 0.375 | 1.75 | 0.2 | 0.3 | 15/16-16 | 1.406 | 125 lbs | 55 | 1 - 3 |
| | 0.250 | XC_2-4308 | | | | | | | | | | 65 | |
| | 0.500 | XC_4-4308 | | | | | | | | | | 76 | |
| 12mm | 5mm | XC_2-12x2.5M | | | | | | | | | | 59 | |
| | 10mm | XC_4-12x2.5M | | | | | | | | | | 73 | |
| 1/2" | .0625 | XC_5016 | | | | | | | | | | 30 | |
| | 0.100 | XC_5010 | | | | | | | | | | 41 | |
| | 0.200 | XC_2-5010 | | | | | | | | | | 57 | |
| | 0.250 | XC_2-5008 | | | | | | | | | | 62 | |
| | 0.500 | XC_4-5008 | | | | | | | | | | 75 | |
| | 0.800 | XC_8-5010 | 80 | | | | | | | | | | |
| | 1.000 | XC_8-5008 | 81 | | | | | | | | | | |

† Patent No. 5839321

Advanced Anti-Backlash Supernuts™

XC 6200

The XC 6200 utilizes the same Patented† ActiveCAM™ as found in the XC 5000 model. Along with the very low drag torque and high axial stiffness advantages, the XC 6200 has greater load capacity.

Note: See Screw Section on page 26 for more information. Specify either XCT or XCF when ordering, see drawings at right.

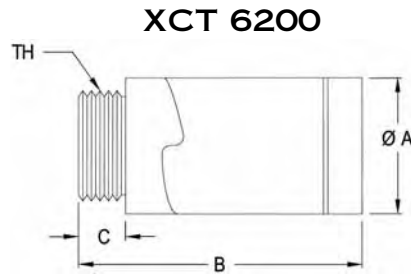

XCF 6200

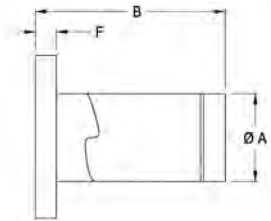
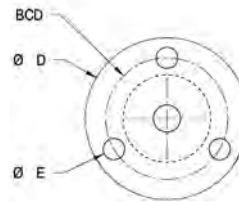

| DIA. | LEAD | PART NO. | SUPERNUT DIMENSIONS | | | | | | | | | EFFICIENCY % | DRAG TORQUE OZ-IN |
|------|-------|-----------|---------------------|------------|-----|------|------|-----|---------|-------|-------------|--------------|-------------------|
| | | | A | B | C | D | E | F | TH | BCD | DESIGN LOAD | | |
| 5/8" | 0.100 | XC_6210 | 1.40 | 2.60 (max) | 0.5 | 2.13 | 0.22 | 0.5 | 1.25-16 | 1.688 | 175 lbs | 35 | 2 - 6 |
| | 0.125 | XC_6208 | | | | | | | | | | 40 | |
| | 4mm | XC_62x4M | | | | | | | | | | 46 | |
| | 0.200 | XC_2-6210 | | | | | | | | | | 51 | |
| | 0.250 | XC_2-6208 | | | | | | | | | | 57 | |
| | 0.500 | XC_4-6208 | | | | | | | | | | 71 | |
| 16mm | 4mm | XC_16x4M | | | | | | | | | | 47 | |

† Patent No. 5839321

Advanced Anti-Backlash Supernuts™

SC 7500

The XC 7500 utilizes BSA's Patented† ActiveCAM™ technology to provide very low drag torque, high axial stiffness and maximum wear life. This self compensating design produces excellent positional repeatability while insuring consistent performance for the long run.

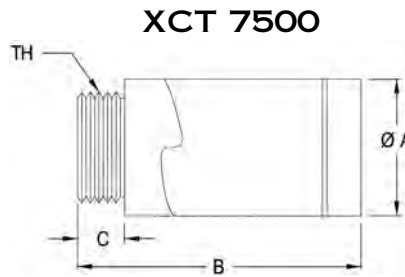

FLANGE F75
(SEE PAGE 83)

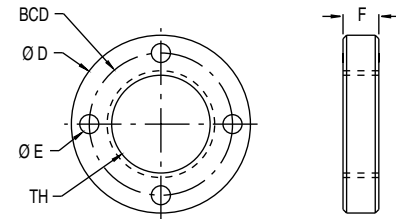

Note: See Screw Section on page 26 for more information.

| DIA. | LEAD | PART NO. | NUT DIMENSIONS | | | TH | FLANGE DIMENSIONS (OPTIONAL) | | | | DESIGN LOAD | EFFICIENCY % | DRAG TORQUE OZ-IN |
|------|-------|------------|----------------|------------|-----|----------|------------------------------|------|------|------|-------------|--------------|-------------------|
| | | | A | B | C | | D | E | F | BCD | | | |
| 3/4" | 0.100 | XCT7510 | 1.63 | 2.9 (max.) | 0.5 | 1 3/8-16 | 2.5 | 0.27 | 0.50 | 2.00 | 250 lbs | 31 | 3 - 10 |
| | 0.125 | XCT7508 | | | | | | | | | | 36 | |
| | 0.167 | XCT7506 | | | | | | | | | | 44 | |
| | 0.200 | XCT7505 | | | | | | | | | | 49 | |
| | 0.500 | XCT5-7510 | | | | | | | | | | 69 | |
| | 1.000 | XCT8-7508 | | | | | | | | | | 79 | |
| | 2.000 | XCT10-7505 | | | | | | | | | | 82 | |
| 20mm | 4mm | XCT20x4M | | | | | | | | | 41 | | |

† Patent No. 5839321

Advanced Anti-Backlash Supernuts™

XC 10000

The XC 10000 utilizes BSA's Patented† ActiveCAM™ technology to provide very low drag torque, high axial stiffness and maximum wear life. This self compensating design produces excellent positional repeatability while insuring consistent performance for the long run.

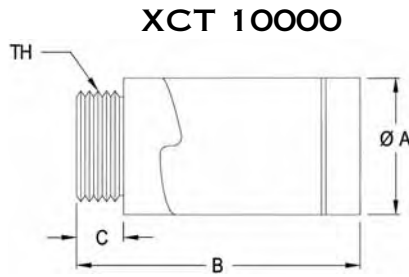

Note: See Screw Section on page 26 for more information.

FLANGE F100 (SEE PAGE 83)

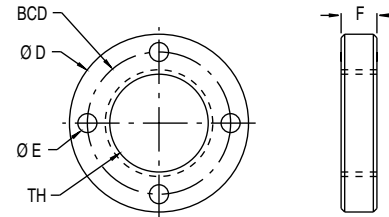

| DIA. | LEAD | PART No. | NUT DIMENSIONS | | | TH | FLANGE DIMENSIONS (OPTIONAL) | | | | DESIGN LOAD | EFFICIENCY % | DRAG TORQUE OZ-IN |
|------|-------|------------|----------------|---------------|------|-----------|---------------------------------|------|------|------|----------------|-----------------|-------------------------|
| | | | A | B | C | | D | E | F | BCD | | | |
| 24mm | 5mm | XCT24x5M | 1.88 | 3.0 (max.) | 0.60 | 1 9/16-18 | 3.0 | 0.27 | 0.60 | 2.37 | 350 lbs | 42 | 5 - 15 |
| 1" | 0.100 | XCT1010 | | | | | | | | | | 25 | |
| | 0.125 | XCT1008 | | | | | | | | | | 29 | |
| | 0.200 | XCT1005 | | | | | | | | | | 41 | |
| | 0.250 | XCT1004 | | | | | | | | | | 47 | |
| | 0.500 | XCT5-1010 | | | | | | | | | | 61 | |
| | 1.000 | XCT10-1010 | | | | | | | | | | 74 | |

† Patent No. 5839321

Advanced Anti-Backlash Supernuts™

AFT

The low cost AFT Supernut is designed for light load OEM applications and offers smooth movement and low drag torque for axial loads up to 10 pounds. The AFT anti-backlash collar automatically adjusts for wear for the life of the nut.

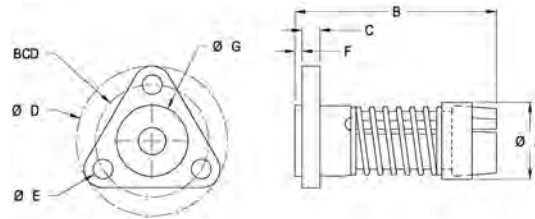

| DIA. | LEAD | PART NO. | SUPERNUT DIMENSIONS | | | | | | | | DESIGN LOAD | EFFICIENCY % | DRAG TORQUE OZ-IN |
|-------|-----------|--------------|---------------------|------|------|------|------|------|------|-------|-------------|--------------|-------------------|
| | | | A | B | C | D | E | F | G | BCD | | | |
| 3/8" | 0.063 | AFT3716 | 0.77 | 2.00 | 0.20 | 1.50 | 0.20 | 0.06 | 0.71 | 1.125 | 10 lbs | 36 | 2 - 5 |
| | 2mm | AFT37x2M | | | | | | | | | | 42 | |
| | 0.083 | AFT3712 | | | | | | | | | | 44 | |
| | 0.100 | AFT3710 | | | | | | | | | | 49 | |
| | 0.125 | AFT3708 | | | | | | | | | | 53 | |
| | 0.167 | AFT2-3712 | | | | | | | | | | 60 | |
| | 0.200 | AFT2-3710 | | | | | | | | | | 65 | |
| | 0.250 | AFT2-3708 | | | | | | | | | | 68 | |
| | 0.375 | AFT4-3711 | | | | | | | | | | 75 | |
| | 0.500 | AFT4-3708 | | | | | | | | | | 79 | |
| | 1.000 | AFT5-3705 | | | | | | | | | | 82 | |
| 1.200 | AFT5-3704 | 82 | | | | | | | | | | | |
| 10mm | 2mm | AFT10x2M | 0.77 | 2.00 | 0.20 | 1.50 | 0.20 | 0.06 | 0.71 | 1.125 | 10 lbs | 41 | 2 - 5 |
| | 3mm | AFT10x3M | | | | | | | | | | 53 | |
| | 6mm | AFT4-10x1.5M | | | | | | | | | | 67 | |
| | 20mm | AFT6-10x3.3M | | | | | | | | | | 81 | |
| 7/16" | 0.125 | AFT2-4316 | 0.77 | 2.00 | 0.20 | 1.50 | 0.20 | 0.06 | 0.71 | 1.125 | 10 lbs | 55 | 2 - 5 |
| | 0.250 | AFT2-4308 | | | | | | | | | | 65 | |
| | 0.500 | AFT4-4308 | | | | | | | | | | 76 | |

Anti-Backlash Supernuts™

SNAB Thread Mount Style

Our SNAB Model has the greatest design flexibility allowing anti-backlash assemblies through 1" diameters. All SNAB's are made from our internally lubricated Acetal providing excellent lubricity and very low wear.

FLANGES

| | |
|---------------|-----|
| 3/16" to 1/4" | F25 |
| 5/16" to 10mm | F37 |

For more information see page 83.

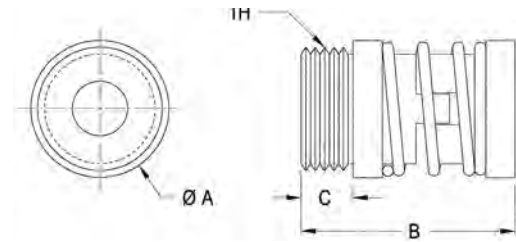

SNAB* 3/16" to 10mm Diameter

| DIA. | LEAD | PART NO. | SUPERNUT DIMENSIONS | | | | | PRELOAD FORCE (LBS) | DESIGN LOAD | MAX. STATIC LOAD | EFFICIENCY % | DRAG TORQUE (OZ-IN) |
|-------|-------------|---------------|---------------------|---------|---------|-------|---------|---------------------|-------------|------------------|--------------|---------------------|
| | | | A | B (MIN) | B (MAX) | C | TH | | | | | |
| 3/16" | 0.050 | SNAB1820X | 0.625 | 1.125 | 1.250 | 0.187 | 9/16-18 | 1 - 3 | 10 lbs | 150 lbs | 49 | 2 - 4 |
| 1/4" | 0.050 | SNAB2520X | 0.625 | 1.125 | 1.250 | 0.187 | 9/16-18 | 1 - 3 | 25 lbs | 225 lbs | 41 | 2 - 4 |
| | 0.063 | SNAB2516X | | | | | | | | | 48 | |
| | 0.250 | SNAB4-2516X | | | | | | | | | 76 | |
| | 0.500 | SNAB7-2514X | | | | | | | | | 81 | |
| 5/16" | 0.083 | SNAB3112X | 0.750 | 1.160 | 1.340 | 0.250 | 5/8-18 | 2 - 5 | 50 lbs | 350 lbs | 49 | 2 - 4 |
| | 0.167 | SNAB2-3112X | | | | | | | | | 65 | |
| | 0.250 | SNAB2-3108X | | | | | | | | | 72 | |
| | 0.500 | SNAB4-3108X | | | | | | | | | 80 | |
| 3/8" | 0.063 | SNAB3716X | 0.750 | 1.160 | 1.340 | 0.250 | 5/8-18 | 2 - 5 | 70 lbs | 350 lbs | 36 | 2 - 4 |
| | 2mm | SNAB37x2M | | | | | | | | | 42 | |
| | 0.083 | SNAB3712X | | | | | | | | | 44 | |
| | 0.100 | SNAB3710X | | | | | | | | | 49 | |
| | 0.125 | SNAB3708X | | | | | | | | | 53 | |
| | 0.167 | SNAB2-3712X | | | | | | | | | 60 | |
| | 0.200 | SNAB2-3710X | | | | | | | | | 65 | |
| | 0.250 | SNAB2-3708X | | | | | | | | | 68 | |
| | 0.375 | SNAB4-3711X | | | | | | | | | 75 | |
| | 0.500 | SNAB4-3708X | | | | | | | | | 79 | |
| | 1.000 | SNAB5-3705X | 82 | | | | | | | | | |
| 1.200 | SNAB5-3704X | 82 | | | | | | | | | | |
| 10mm | 2mm | SNAB10x2M | 0.750 | 1.160 | 1.340 | 0.250 | 5/8-18 | 2 - 5 | 70 lbs | 350 lbs | 41 | 2 - 4 |
| | 3mm | SNAB10x3M | | | | | | | | | 53 | |
| | 6mm | SNAB4-10x1.5M | | | | | | | | | 67 | |
| | 20mm | SNAB6-10x3.3M | | | | | | | | | 81 | |

*SNAB nuts are only as axially stiff as the spring force in one direction.

Anti-Backlash Supernuts™

FLANGES

| | |
|---------------|------|
| 7/16" to 16mm | F50 |
| 3/4" to 1" | F100 |

SNAB* 7/16" to 1" Diameter

For more information see page 83.

| DIA. | LEAD | PART NO. | SUPERNUT DIMENSIONS | | | | | PRELOAD FORCE (LBS) | DESIGN LOAD | MAX. STATIC LOAD | EFFICIENCY % | DRAG TORQUE (OZ-IN) |
|-------|--------|---------------|---------------------|---------|---------|-------|-----------|---------------------|-------------|------------------|--------------|---------------------|
| | | | A | B (MIN) | B (MAX) | C | TH | | | | | |
| 7/16" | 0.125 | SNAB2-4316X | 1.000 | 1.700 | 2.000 | 0.375 | 15/16-16 | 4 - 9 | 100 lbs | 500 lbs | 55 | 3 - 5 |
| | 0.250 | SNAB2-4308X | | | | | | | | | 65 | |
| | 0.500 | SNAB4-4308X | | | | | | | | | 76 | |
| 12mm | 5mm | SNAB2-12x2.5M | 1.000 | 1.700 | 2.000 | 0.375 | 15/16-16 | 4 - 9 | 100 lbs | 500 lbs | 59 | 3 - 5 |
| | 10mm | SNAB4-12x2.5M | | | | | | | | | 73 | |
| 1/2" | 0.0625 | SNAB5016 | 1.000 | 1.700 | 2.000 | 0.375 | 15/16-16 | 4 - 9 | 150 lbs | 750 lbs | 30 | 5 - 8 |
| | 0.100 | SNAB5010X | | | | | | | | | 41 | |
| | 0.200 | SNAB2-5010X | | | | | | | | | 57 | |
| | 0.250 | SNAB2-5008X | | | | | | | | | 62 | |
| | 0.500 | SNAB4-5008X | | | | | | | | | 75 | |
| | 0.800 | SNAB8-5010X | | | | | | | | | 80 | |
| | 1.000 | SNAB8-5008X | | | | | | | | | 81 | |
| 5/8" | 0.100 | SNAB6210X | 1.000 | 1.700 | 2.000 | 0.375 | 15/16-16 | 4 - 9 | 160 lbs | 800 lbs | 35 | 7 - 10 |
| | 0.125 | SNAB6208X | | | | | | | | | 40 | |
| | 4mm | SNAB62x4M | | | | | | | | | 46 | |
| | 0.200 | SNAB2-6210X | | | | | | | | | 51 | |
| | 0.250 | SNAB2-6208X | | | | | | | | | 57 | |
| | 0.500 | SNAB4-6208X | | | | | | | | | 71 | |
| 16mm | 4mm | SNAB16x4M | 1.000 | 1.700 | 2.000 | 0.375 | 15/16-16 | 4 - 9 | 160 lbs | 800 lbs | 47 | 7 - 10 |
| 3/4" | 0.100 | SNAB7510X | 1.750 | 2.500 | 3.000 | 0.600 | 1 9/16-18 | 10 - 20 | 300 lbs | 1500 lbs | 31 | 15 - 20 |
| | 0.125 | SNAB7508X | | | | | | | | | 36 | |
| | 0.167 | SNAB7506X | | | | | | | | | 44 | |
| | 0.200 | SNAB7505X | | | | | | | | | 49 | |
| | 0.500 | SNAB5-7510X | | | | | | | | | 69 | |
| | 1.000 | SNAB8-7508X | | | | | | | | | 79 | |
| | 2.000 | SNAB10-7505X | | | | | | | | | 82 | |
| 20mm | 4mm | SNAB20x4M | 1.750 | 2.500 | 3.000 | 0.600 | 1 9/16-18 | 10 - 20 | 300 lbs | 1500 lbs | 41 | 15 - 20 |
| 24mm | 5mm | SNAB24x5M | 1.750 | 2.500 | 3.000 | 0.600 | 1 9/16-18 | 10 - 20 | 300 lbs | 1500 lbs | 42 | 15 - 20 |
| 1" | 0.100 | SNAB1010X | 1.750 | 2.500 | 3.000 | 0.600 | 1 9/16-18 | 10 - 20 | 400 lbs | 2000 lbs | 25 | 15 - 20 |
| | 0.125 | SNAB1008X | | | | | | | | | 29 | |
| | 0.200 | SNAB1005X | | | | | | | | | 41 | |
| | 0.250 | SNAB1004X | | | | | | | | | 47 | |
| | 0.500 | SNAB5-1010X | | | | | | | | | 61 | |
| | 1.000 | SNAB5-1005X | | | | | | | | | 74 | |

*SNAB nuts are only as axially stiff as the spring force in one direction.

Flange Mount Supernuts™

MTS Integral Flange Mount

The MTS models provide the excellent lubricity and dimensional stability of our proprietary Acetal with the convenience of an integral flange.

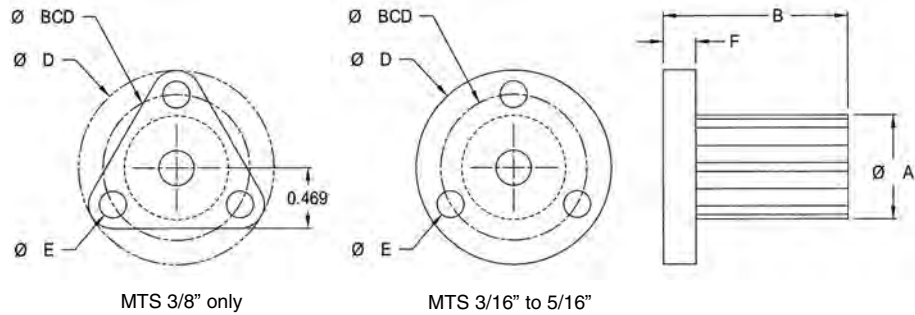

MTS 3/16" to 3/8" Diameter

| DIA. | LEAD | PART NO. | SUPERNUT DIMENSIONS | | | | | | DESIGN LOAD | EFFICIENCY % | DRAG TORQUE |
|-------|-----------|-----------|---------------------|------|------|------|------|-------|-------------|--------------|---------------|
| | | | A | B | D | E | F | BCD | | | |
| 3/16" | 0.050 | MTS1820 | 0.50 | 0.75 | 1.00 | 0.14 | 0.15 | 0.75 | 10 lbs | 49 | Free Wheeling |
| 1/4" | 0.050 | MTS2520 | 0.50 | 0.75 | 1.00 | 0.14 | 0.15 | 0.75 | 25 lbs | 41 | |
| | 0.063 | MTS2516 | | | | | | | | 48 | |
| | 0.250 | MTS4-2516 | | | | | | | | 76 | |
| | 0.500 | MTS7-2514 | | | | | | | | 81 | |
| 5/16" | 0.083 | MTS3112 | 0.50 | 0.75 | 1.00 | 0.14 | 0.15 | 0.75 | 50 lbs | 49 | |
| | 0.167 | MTS2-3112 | | | | | | | | 65 | |
| | 0.250 | MTS2-3108 | | | | | | | | 72 | |
| | 0.500 | MTS4-3108 | | | | | | | | 80 | |
| 3/8"* | 0.063 | MTS3716 | 0.71 | 1.50 | 1.5 | 0.20 | 0.20 | 1.125 | 60 lbs | 36 | |
| | 2mm | MTS37x2M | | | | | | | | 42 | |
| | 0.083 | MTS3712 | | | | | | | | 44 | |
| | 0.100 | MTS3710 | | | | | | | | 49 | |
| | 0.125 | MTS3708 | | | | | | | | 53 | |
| | 0.167 | MTS2-3712 | | | | | | | | 60 | |
| | 0.200 | MTS2-3710 | | | | | | | | 65 | |
| | 0.250 | MTS2-3708 | | | | | | | | 68 | |
| | 0.375 | MTS4-3711 | | | | | | | | 75 | |
| | 0.500 | MTS4-3708 | | | | | | | | 79 | |
| | 1.000 | MTS5-3705 | | | | | | | | 82 | |
| 1.200 | MTS5-3704 | 82 | | | | | | | | | |

*3/8" to 7/16" with tri-flange.

Flange Mount Supernuts™

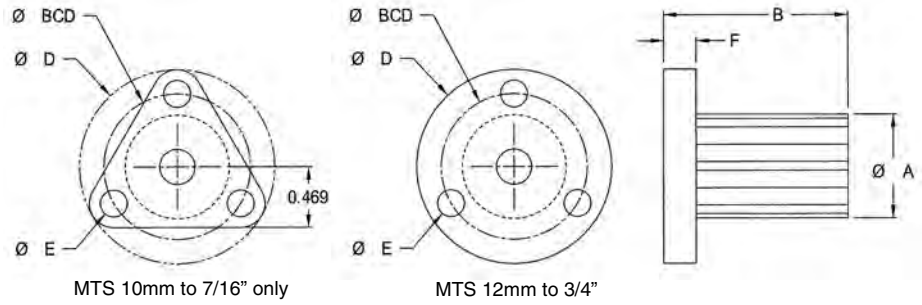

MTS 10mm to 3/4" Diameter

| DIA. | LEAD | PART NO. | SUPERNUT DIMENSIONS | | | | | | DESIGN LOAD | EFFICIENCY % | DRAG TORQUE |
|---------|--------|--------------|---------------------|------|-----|------|-------|-------|-------------|--------------|---------------|
| | | | A | B | D | E | F | BCD | | | |
| 10mm* | 2mm | MTS10x2M | 0.71 | 1.50 | 1.5 | 0.20 | 0.200 | 1.125 | 75 lbs | 41 | Free Wheeling |
| | 3mm | MTS10x3M | | | | | | | | 53 | |
| | 6mm | MTS4-10x1.5M | | | | | | | | 67 | |
| | 20mm | MTS6-10x3.3M | | | | | | | | 81 | |
| 7/16"** | 0.125 | MTS2-4316 | 0.71 | 1.50 | 1.5 | 0.20 | 0.200 | 1.125 | 75 lbs | 55 | |
| | 0.250 | MTS2-4308 | | | | | | | | 65 | |
| | 0.500 | MTS4-4308 | | | | | | | | 76 | |
| 12mm | 5mm | MTS2-12x2.5M | 0.75 | 1.50 | 1.5 | 0.20 | 0.250 | 1.125 | 125 lbs | 59 | |
| | 10mm | MTS4-12x2.5M | | | | | | | | 73 | |
| 1/2" | 0.0625 | MTS5016 | 0.75 | 1.50 | 1.5 | 0.20 | 0.250 | 1.125 | 125 lbs | 30 | |
| | 0.100 | MTS5010 | | | | | | | | 41 | |
| | 0.200 | MTS2-5010 | | | | | | | | 57 | |
| | 0.250 | MTS2-5008 | | | | | | | | 62 | |
| | 0.500 | MTS4-5008 | | | | | | | | 75 | |
| | 0.800 | MTS8-5010 | | | | | | | | 80 | |
| | 1.000 | MTS8-5008 | | | | | | | | 81 | |
| 5/8" | 0.100 | MTS6210 | 0.88 | 1.63 | 1.5 | 0.20 | 0.300 | 1.188 | 175 lbs | 35 | |
| | 0.125 | MTS6208 | | | | | | | | 40 | |
| | 4mm | MTS62x4M | | | | | | | | 46 | |
| | 0.200 | MTS2-6210 | | | | | | | | 51 | |
| | 0.250 | MTS2-6208 | | | | | | | | 57 | |
| | 0.500 | MTS4-6208 | | | | | | | | 71 | |
| 16mm | 4mm | MTS16x4M | 0.88 | 1.63 | 1.5 | 0.20 | 0.300 | 1.188 | 175 lbs | 47 | |
| 3/4" | 0.100 | MTS7510 | 1.125 | 1.75 | 2.0 | 0.20 | 0.300 | 1.438 | 275 lbs | 31 | |
| | 0.125 | MTS7508 | | | | | | | | 36 | |
| | 0.167 | MTS7506 | | | | | | | | 44 | |
| | 0.200 | MTS7505 | | | | | | | | 49 | |
| | 0.500 | MTS5-7510 | | | | | | | | 69 | |
| | 1.000 | MTS8-7508 | | | | | | | | 79 | |
| | 2.000 | MTS10-7505 | | | | | | | | 82 | |

*3/8" to 7/16" with tri-flange.

Thread Mount Supernuts™

SN

Our standard SN nuts have proven themselves for the past twenty years. Available in sizes from 3/16" to 1-1/2" with or without mounting flanges.

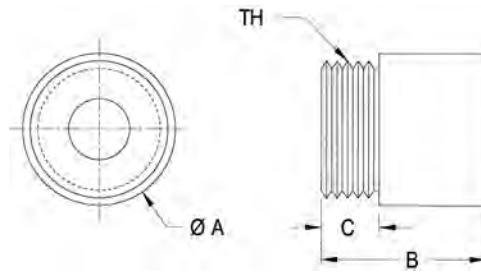

FLANGES

| | |
|---------------|-------|
| 3/16" to 1/4" | F25 |
| 5/16" to 10mm | F37 |
| 7/16" to 16mm | F50 |
| 3/4" to 1" | F75 |
| 1-1/4" | F100 |
| 1-1/2" | R54-3 |

For more information see page 83.

SN

3/16" to 7/16" Diameter*

| DIA. | LEAD | PART NO. | SUPERNUT DIMENSIONS | | | | DESIGN LOAD | MAX. STATIC LOAD | EFFICIENCY % | FLANGE |
|-------|-------|-------------|---------------------|-------|-------|----------|-------------|------------------|--------------|--------|
| | | | A | B | C | TH | | | | |
| 3/16" | 0.050 | SN1820X | 0.625 | 0.500 | 0.187 | 9/16-18 | 30 lbs | 150 lbs | 49 | F25 |
| 1/4" | 0.050 | SN2520X | 0.625 | 0.500 | 0.187 | 9/16-18 | 45 lbs | 225 lbs | 41 | |
| | 0.063 | SN2516X | | | | | | | 48 | |
| | 0.250 | SN4-2516X | | | | | | | 76 | |
| | 0.500 | SN7-2514X | | | | | | | 81 | |
| 5/16" | 0.083 | SN3112X | 0.750 | 0.750 | 0.250 | 5/8-18 | 70 lbs | 350 lbs | 49 | F37 |
| | 0.167 | SN2-3112X | | | | | | | 65 | |
| | 0.250 | SN2-3108X | | | | | | | 72 | |
| | 0.500 | SN4-3108X | | | | | | | 80 | |
| 3/8" | 0.063 | SN3716X | 0.750 | 0.750 | 0.250 | 5/8-18 | 70 lbs | 350 lbs | 36 | |
| | 2mm | SN37x2M | | | | | | | 42 | |
| | 0.083 | SN3712X | | | | | | | 44 | |
| | 0.100 | SN3710X | | | | | | | 49 | |
| | 0.125 | SN3708X | | | | | | | 53 | |
| | 0.167 | SN2-3712X | | | | | | | 60 | |
| | 0.200 | SN2-3710X | | | | | | | 65 | |
| | 0.250 | SN2-3708X | | | | | | | 68 | |
| | 0.375 | SN4-3711X | | | | | | | 75 | |
| | 0.500 | SN4-3708X | | | | | | | 79 | |
| | 1.000 | SN5-3705X | | | | | | | 82 | |
| 10mm | 2mm | SN10x2M | 0.750 | 0.750 | 0.250 | 5/8-18 | 70 lbs | 350 lbs | 41 | F50 |
| | 3mm | SN10x3M | | | | | | | 53 | |
| | 6mm | SN4-10x1.5M | | | | | | | 67 | |
| | 20mm | SN6-10x3.3M | | | | | | | 81 | |
| 7/16" | 0.125 | SN2-4316X | 1.000 | 1.000 | 0.375 | 15/16-16 | 100 lbs | 500 lbs | 55 | |
| | 0.250 | SN2-4308X | | | | | | | 65 | |
| | 0.500 | SN4-4308X | | | | | | | 76 | |

*For all sizes shown on this page Drag Torque = Free Wheeling.

Thread Mount Supernuts™

SN 12mm to 1-1/2" Diameter*

| DIA. | LEAD | PART NO. | SUPERNUT DIMENSIONS | | | | DESIGN LOAD | MAX. STATIC LOAD | EFFICIENCY % | FLANGE |
|--------|--------|-------------|---------------------|-------|-------|-----------|-------------|------------------|--------------|--------|
| | | | A | B | C | TH | | | | |
| 12mm | 5mm | SN2-12x2.5M | 1.000 | 1.000 | 0.375 | 15/16-16 | 100 lbs | 500 lbs | 59 | F50 |
| | 10mm | SN4-12x2.5M | | | | | | | 73 | |
| 1/2" | 0.0625 | SN5016X | 1.000 | 1.000 | 0.375 | 15/16-16 | 150 lbs | 750 lbs | 30 | |
| | 0.100 | SN5010X | | | | | | | 41 | |
| | 0.200 | SN2-5010X | | | | | | | 57 | |
| | 0.250 | SN2-5008X | | | | | | | 62 | |
| | 0.500 | SN4-5008X | | | | | | | 75 | |
| | 0.800 | SN8-5010X | | | | | | | 80 | |
| | 1.000 | SN8-5008X | | | | | | | 81 | |
| 5/8" | 0.100 | SN6210X | 1.000 | 1.000 | 0.375 | 15/16-16 | 160 lbs | 800 lbs | 35 | |
| | 0.125 | SN6208X | | | | | | | 40 | |
| | 4mm | SN62x4M | | | | | | | 46 | |
| | 0.200 | SN2-6210X | | | | | | | 51 | |
| | 0.250 | SN2-6208X | | | | | | | 57 | |
| | 0.500 | SN4-6208X | | | | | | | 71 | |
| 16mm | 4mm | SN16x4M | 1.000 | 1.000 | 0.375 | 15/16-16 | 160 lbs | 800 lbs | 47 | F75 |
| 3/4" | 0.100 | SN7510X | 1.500 | 1.500 | 0.500 | 1 3/8-16 | 300 lbs | 1500 lbs | 31 | |
| | 0.125 | SN7508X | | | | | | | 36 | |
| | 0.167 | SN7506X | | | | | | | 44 | |
| | 0.200 | SN7505X | | | | | | | 49 | |
| | 0.500 | SN5-7510X | | | | | | | 69 | |
| | 1.000 | SN8-7508X | | | | | | | 79 | |
| | 2.000 | SN10-7505X | | | | | | | 82 | |
| 20mm | 4mm | SN20x4M | 1.500 | 1.500 | 0.500 | 1 3/8-16 | 300 lbs | 1500 lbs | 41 | |
| 24mm | 5mm | SN24x5M | 1.500 | 1.500 | 0.500 | 1 3/8-16 | 300 lbs | 1500 lbs | 42 | |
| 1" | 0.100 | SN1010X | 1.500 | 1.500 | 0.500 | 1 3/8-16 | 400 lbs | 2000 lbs | 25 | |
| | 0.125 | SN1008X | | | | | | | 29 | |
| | 0.200 | SN1005X | | | | | | | 41 | |
| | 0.250 | SN1004X | | | | | | | 47 | |
| | 0.500 | SN5-1010X | | | | | | | 61 | |
| | 1.000 | SN10-1010X | | | | | | | 74 | |
| 1 1/4" | 0.200 | SN1205X | 2.000 | 2.500 | 0.600 | 1 9/16-18 | 400 lbs | 2000 lbs | 35 | F100 |
| | 0.250 | SN1204X | | | | | | | 41 | |
| 1 1/2" | 0.200 | SN1505X | 2.000 | 2.500 | 0.530 | 1.967-18 | 400 lbs | 2000 lbs | 31 | R54-3 |
| | 0.250 | SN1504X | | | | | | | 36 | |
| | 0.375 | SN1503X | | | | | | | 47 | |
| | 0.500 | SN2-1504X | | | | | | | 52 | |

*For all sizes shown on this page Drag Torque = Free Wheeling.

Bronze Nuts

For Acme Screws, Thread Mount Style

For standard bronze nuts Ball Screws and Actuators uses SAE 660 bearing bronze which provides excellent load carrying ability, good wear resistance and is less susceptible to damage from impact and shock loading. Custom bronzes can be selected if required.

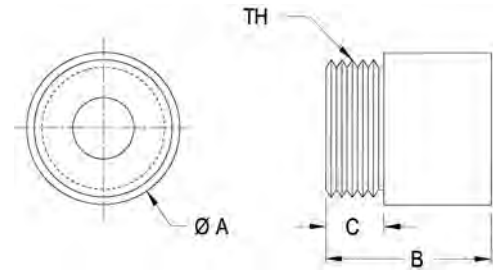

MATERIAL PROPERTIES

| MAXIMUM TEMPERATURE | FRICTION COEFFICIENT | MATERIAL * | TENSILE STRENGTH |
|---------------------|----------------------|------------|------------------|
| max. 250°F | 0.2 to 0.3 | 660 SAE | 35,000 psi |

*Other materials available on a custom basis.

1/4" to 5/8" Diameter

| DIA. | LEAD | NUT PART NO. FOR R.H. SCREWS | NUT PART NO. FOR L.H. SCREWS | BRONZE NUT DIMENSIONS | | | | FITS FLANGE No. (PAGE 83) | DESIGN LOAD† | MAXIMUM STATIC LOAD | TORQUE TO RAISE 1 POUND (IN-OZ) |
|------|-------|------------------------------|------------------------------|-----------------------|------|------|----------|---------------------------|--------------|---------------------|---------------------------------|
| | | | | A | B | C | TH | | | | |
| 1/4 | .050 | BN2520 | BN2520L | .625 | .625 | .187 | 9/16-18 | F25 | 110 lbs | 550 lbs | .41 |
| | .0625 | BN2516 | — | | | | | | | | .43 |
| | .250 | BN4-2516 | — | | | | | | | | 1.0 |
| 3/8 | .0625 | BN3716 | — | .750 | .750 | .250 | 5/8-18 | F37 | 300 lbs | 1,500 lbs | .61 |
| | .0833 | BN3712 | BN3712L | | | | | | | | .64 |
| | .100 | BN3710 | BN3710L | | | | | | | | .67 |
| | .125 | BN3708S | — | | | | | | | | .76 |
| | .167 | BN2-3712S | — | | | | | | | | .86 |
| 1/2 | .100 | BN5010 | BN5010L | 1.00 | 1.00 | .375 | 15/16-16 | F50 | 620 lbs | 3,100 lbs | .83 |
| | .200 | BN2-5010 | — | | | | | | | | 1.10 |
| 5/8 | .100 | BN6210 | BN6210L | 1.00 | 1.00 | .375 | 15/16-16 | F50 | 860 lbs | 4,300 lbs | .99 |
| | .125 | BN6208S | — | | | | | | | | 1.06 |
| | .200 | BN2-6210 | — | | | | | | | | 1.26 |

†Load ratings based on using BSA grease. See page 80.

Bronze Nuts

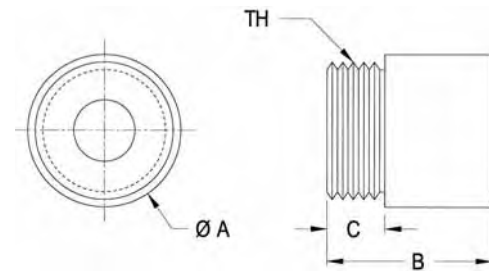

For Acme Screws, Thread Mount Style 3/4" to 3" Diameter

| DIA. | LEAD | NUT PART NO. FOR R.H. SCREWS | NUT PART NO. FOR L.H. SCREWS | BRONZE NUT DIMENSIONS | | | | FITS FLANGE NO. (PAGE 83) | DESIGN LOAD† | MAXIMUM STATIC LOAD | TORQUE TO RAISE 1 POUND (IN-OZ) |
|-------|------|------------------------------------|------------------------------------|-----------------------|------|------|-----------|------------------------------------|-----------------|------------------------|--|
| | | | | A | B | C | TH | | | | |
| 3/4 | .100 | BN7510 | BN7510L | 1.50 | 1.50 | .500 | 1 3/8-16 | F75 | 1,500 lbs | 7,500 lbs | 1.15 |
| | .125 | BN7508 | — | | | | | | | | 1.21 |
| | .167 | BN7506 | BN7506L | | | | | | | | 1.28 |
| | .200 | BN7505 | BN7505L | | | | | | | | 1.35 |
| 1 | .100 | BN1010 | — | 1.50 | 1.50 | .500 | 1 3/8-16 | F75 | 1,900 lbs | 9,500 lbs | 1.47 |
| | .125 | BN1008 | — | | | | | | | | 1.52 |
| | .200 | BN1005 | — | | | | | | | | 1.67 |
| | .250 | BN1004 | — | | | | | | | | 1.76 |
| | .500 | BN5-1010 | — | | | | | | | | 2.55 |
| | 1.00 | BN10-1010 | — | | | | | | | | 3.91 |
| 1 1/4 | .200 | BN1205* | — | 1.75 | 1.75 | .625 | 1 9/16-18 | R1004-3 | 3,000 lbs | 15,000 lbs | 1.99 |
| | .250 | BN1204* | — | | | | | | | | 2.09 |
| 1 1/2 | .200 | BN1505* | — | 2.25 | 2.25 | .530 | 1.967-18 | R54-3 | 4,600 lbs | 23,000 lbs | 2.31 |
| | .250 | BN1504* | — | | | | | | | | 2.41 |
| | .375 | BN1503* | — | | | | | | | | 2.56 |
| | .500 | BN2-1504* | — | | | | | | | | 3.08 |
| 2 | .250 | BN2004* | — | 2.75 | 3.50 | .780 | 2.548-18 | R50-3 | 8,000 lbs | 40,000 lbs | 3.04 |
| 2 1/4 | .250 | BN2204* | — | 3.37 | 3.00 | 1.56 | 3.137-12 | R2202-3 | 12,800 lbs | 64,000 lbs | 3.70 |
| 2 1/2 | .250 | BN2504* | — | 3.37 | 3.00 | 1.56 | 3.137-12 | R2202-3 | 16,000 lbs | 80,000 lbs | 3.90 |
| 2 3/4 | .250 | BN2704* | — | 4.00 | 4.00 | 1.75 | 3.625-12 | R2501-3 | 20,000 lbs | 100,000 lbs | 4.20 |
| 3 | .250 | BN3004* | — | 4.00 | 4.00 | 1.75 | 3.625-12 | R2501-3 | 23,000 lbs | 115,000 lbs | 4.50 |

†Load ratings based on using BSA grease. See page 80.

*Non-stock item

Lead Screws

"Acme" Style Rolled Thread 3/16" to 1/2" Diameter

| NOMINAL MAJOR DIAMETER | LEAD | PRECISION PREFIX | STANDARD PREFIX | BSA PART NO. | AVAIL IN LEFT HAND | MATERIAL | ROOT DIAMETER | RECOMMENDED BEARING SEE PAGE 51. |
|------------------------|--------|------------------|-----------------|--------------|--------------------|-----------------|---------------|----------------------------------|
| 3/16" | 0.050 | SPR | SRA | 1820 | L | Stainless Steel | 0.12 | N/A |
| 1/4" | 0.050 | SPR | SRA | 2520 | L | Stainless Steel | 0.19 | 4 mm |
| | 0.063 | | | 2516 | L | | 0.17 | |
| | 0.250 | | | 4-2516 | | | 0.17 | |
| | 0.500 | N/A | | 7-2514 | | | 0.16 | |
| 5/16" | 0.083 | SPR | SRA | 3112 | L | Stainless Steel | 0.22 | 4 mm |
| | 0.167 | | | 2-3112 | | | 0.20 | |
| | 0.250 | | | 2-3108S | | | 0.22 | |
| | 0.500 | | | 4-3108S | | | 0.21 | |
| 3/8" | 0.0625 | SPR | SRA | 3716 | L | Stainless Steel | 0.30 | 4mm |
| | 2mm | | | 37x2M | L | | 0.28 | |
| | 0.083 | | | 3712 | L | | 0.28 | |
| | 0.100 | | | 3710 | L | | 0.26 | |
| | 0.125 | | | 3708S | L | | 0.29 | |
| | 0.167 | | | 2-3712S | | | 0.31 | |
| | 0.200 | | | 2-3710 | | | 0.26 | |
| | 0.250 | | | 2-3708S | L | | 0.29 | |
| | 0.375 | | | 4-3711 | L | | 0.27 | |
| | 0.500 | | | 4-3708S | L | | 0.27 | |
| | 1.00 | N/A | | 5-3705 | | | 0.24 | |
| | 1.20 | N/A | | 5-3704 | | | 0.24 | |
| 10mm | 2mm | SPT | SRT | 10x2M | L | Stainless Steel | 0.31 | 4mm |
| | 3mm | | | 10x3M | | | 0.27 | |
| | 6mm | SPR | SRA | 4-10x1.5M | | | 0.31 | |
| | 20mm | | | 6-10x3.3M | | | 0.30 | |
| 7/16" | 0.125 | SPR | SRA | 2-4316 | | Stainless Steel | 0.35 | 6mm |
| | 0.250 | | | 2-4308S | | | 0.36 | |
| | 0.500 | | | 4-4308S | | | 0.33 | |
| 12mm | 5mm | SPT | SRT | 2-12x2.5M | | Stainless Steel | 0.35 | 6mm |
| | 10mm | | | 4-12x2.5M | | | 0.35 | |
| 1/2" | 0.0625 | SPR | SRA | 5016 | | Stainless Steel | 0.41 | 6mm |
| | 0.100 | | | 5010 | L | | 0.37 | |
| | 0.200 | | | 2-5010 | | | 0.39 | |
| | 0.250 | | | 2-5008 | | | 0.38 | |
| | 0.500 | | | 4-5008 | | | 0.36 | |
| | 0.800 | N/A | | 8-5010 | | | 0.37 | |
| | 1.000 | N/A | | 8-5008 | | | 0.39 | |

Lead Screws

"Acme" Style Rolled Thread 5/8" to 3" Diameter

| NOMINAL MAJOR DIAMETER | LEAD | PRECISION PREFIX | STANDARD PREFIX | BSA PART NO. | AVAIL IN LEFT HAND | MATERIAL | ROOT DIAMETER | RECOMMENDED BEARING SEE PAGE 51. |
|------------------------|-------|------------------|-----------------|--------------|--------------------|------------------|---------------|----------------------------------|
| 5/8" | 0.100 | SPR | SRA | 6210 | L | Stainless Steel | 0.52 | 8mm |
| | 0.125 | | | 6208S | L | | 0.52 | |
| | 4mm | N/A | | 62 x 4MS | L | | 0.52 | |
| | 0.200 | SPR | | 2-6210 | | | 0.52 | |
| | 0.250 | | | 2-6208S | | | 0.52 | |
| | 0.500 | | | 4-6208 | | | 0.48 | |
| 16mm | 4mm | N/A | SRT | 16 x 4M | L | Stainless Steel | 0.45 | 8mm |
| 3/4" | 0.100 | SPR | SRA | 7510 | L | Stainless Steel | 0.63 | 12mm |
| | 0.125 | | | 7508 | L | | 0.61 | |
| | 0.167 | | | 7506 | L | | 0.56 | |
| | 0.200 | | | 7505 | L | | 0.53 | |
| | 0.500 | N/A | | 5-7510 | | | 0.62 | |
| | 1.000 | | | 8-7508 | | | 0.61 | |
| | 2.000 | | | 10-7505† | L | | 0.59 | |
| 20mm | 4mm | SPT | SRT | 20 x 4M | L | Stainless Steel | 0.61 | 12mm |
| 24mm | 5mm | SPT | SRT | 24 x 5M | L | Stainless Steel | 0.73 | 12mm |
| 1" | 0.100 | SPR | SRA | 1010 | L | Stainless Steel | 0.88 | 12 to 20mm |
| | 0.125 | N/A | | 1008 | L | | 0.86 | 12 to 20mm |
| | 0.200 | SPR | | 1005 | L | | 0.78 | 12mm |
| | 0.250 | N/A | | 1004 | L | Carbon Steel | 0.72 | 12mm |
| | 0.500 | | | 5-1010 | | Stainless Steel | 0.88 | 12 to 20mm |
| | 1.000 | | | 10-1010 | | 0.88 | 12 to 20mm | |
| 1 1/4" | 0.200 | N/A | RA | 1205 | L | Low Carbon Steel | 1.03 | 20mm |
| | 0.250 | | | 1204 | L | | 0.98 | |
| 1 1/2" | 0.200 | N/A | RA | 1505 | L | Low Carbon Steel | 1.28 | 25mm |
| | 0.250 | | | 1504 | L | | 1.23 | |
| | 0.375 | | | 1503 | | | 1.11 | |
| | 0.500 | | | 2-1504 | | | 1.23 | |
| 2" | 0.250 | N/A | RA | 2004 | L | Low Carbon Steel | 1.73 | * |
| 2 1/4" | 0.250 | N/A | RA | 2204 | L | | 1.98 | * |
| 2 1/2" | 0.250 | N/A | RA | 2504 | L | | 2.23 | * |
| 2 3/4" | 0.250 | N/A | RA | 2704 | L | | 2.48 | * |
| 3" | 0.250 | N/A | RA | 3004 | L | | 2.73 | * |
| | | | | | | | | |

† Nominal O.D. is .734"

VEE Thread Screws

Burnished Finish 303 Stainless Steel

- Some sizes available in 1018 Steel.
- Matching Supernuts and Left Hand Screws on special request.

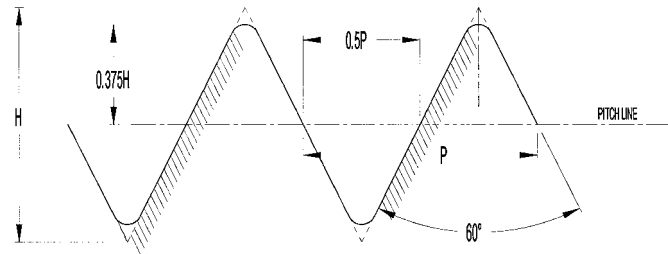

| DIAMETER | LEAD | SIZE | PART NO. | RECOMMENDED BEARING SEE PAGE 51. |
|----------|-------|----------|----------|-------------------------------------|
| 6 mm | 1 mm | 6 x 1 mm | SV6x1 | 4 mm |
| 1/4" | .0125 | 1/4-80 | SV2580 | 4 mm |
| | .0208 | 1/4-48 | SV2548 | |
| | .0250 | 1/4-40 | SV2540 | |
| | .0278 | 1/4-36 | SV2536 | |
| | .0313 | 1/4-32 | SV2532 | |
| | .0357 | 1/4-28 | SV2528 | |
| | .0417 | 1/4-24 | SV2524 | |
| | .0500 | 1/4-20 | SV2520 | |
| 3/8" | .0250 | 3/8-40 | SV3740 | 4 or 6 mm |
| | .0313 | 3/8-32 | SV3732 | |
| | .0417 | 3/8-24 | SV3724 | |
| | .0500 | 3/8-20 | SV3720 | |
| | .0625 | 3/8-16 | SV3716 | |
| | .0833 | 3/8-12 | SV3712 | |
| 1/2" | .0250 | 1/2-40 | SV5040 | 6 or 8mm |
| | .0333 | 1/2-30 | SV5030 | |
| | .0500 | 1/2-20 | SV5020 | |
| | .0625 | 1/2-16 | SV5016 | |
| | .0708 | 1/2-13 | SV5013 | |

Ball Screws



| | |
|--|----|
| Ball Screw Selection Guide | 30 |
| Precision Rolled Ball Screw Assemblies | |
| Precision Rolled 3/8" to 3/4" diameter | 32 |
| Precision Rolled 1" to 1-1/2" diameter | 36 |
| Precision Rolled 2" to 4" diameter | 40 |
| Miniature Rolled Ball Screw Assemblies | |
| Miniature Rolled Ball Screw Assemblies | 43 |
| Precision Rolled 4mm to 14mm diameter | 44 |
| Precision Ground Ball Screw Assemblies | |
| Precision Ground 16mm to 38mm diameter | 47 |
| Precision Ground 25mm to 50mm diameter | 48 |
| Precision Ground Ball Screw Availability | 49 |

Ball Screw Selection Guide

Ball Bearing Screw Selection Process

For the selection of ball bearing screws, BSA has developed a simplified process. By applying the four steps which follow, the proper size ball bearing screw can readily be selected for most applications. This four step process includes:

- Determine the load
- Determine the design life objective
- Verify safe speed
- Verify safe compression load

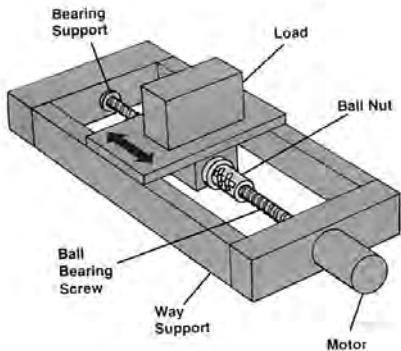

If unique design considerations are encountered in your application, consult the factory for in-depth technical assistance.

STEP 1. Determine the load

The key step here is to determine the load "as seen by the screw." Essentially, the load applied in a vertical application, such as lifting or jacking, is the same as the weight of the load.

VERTICAL APPLICATION

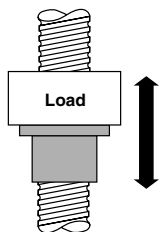

HORIZONTAL APPLICATION

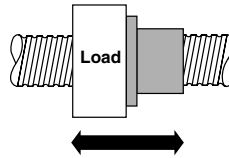

Lifting or pushing an automobile is a good analogy for explaining this relationship. It may be impossible to lift a 3,000 pound automobile, but it is possible to push it. The "load seen" in pushing the auto is the weight of the auto times the coefficient of friction of the wheels.

The load seen by a ball bearing screw is the weight of the load times the coefficient of friction of the bearing supports. For example, take a 3,000 pound load supported on way bearings with a coefficient of friction of .2. The force required to move the load would be 3,000 lb. x .2 = 600 lbs. This is the load as seen by the screw.

Typical coefficient of friction for various bearing surfaces are:

SLIDES/WAYS

| | |
|------------------------------|-------|
| Bronze on steel (lubricated) | = .16 |
| Steel on steel (lubricated) | = .18 |

BEARINGS

| | |
|----------------------|--------|
| Ball bushings | = .001 |
| Rollerway bushings | = .005 |
| Ball bearing splines | = .005 |

Another practical way to determine the load in an actual application is to attach a spring scale to the load and pull it. Base the load on the moving force required, not on the higher starting (breakaway) force.

STEP 2. Determine the design life objective

The design life objective is the number of inches that a ball bearing nut will travel during the desired life of the machine.

VERTICAL APPLICATION

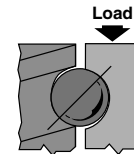

Example of calculating life in a vertical application:

- Length of stroke: 8 inches
- Cycle rate of machine: 25 strokes/hr.
- Estimated machine operation/day: 16 hrs/day
- Number of working days/year: 225 days
- Number of years machine is designed for: 10 years

Counting one trip up (8 inches) and one trip down (8 inches) for each cycle the design life objective in this example is:

$$8 \times 2 \times 25 \times 16 \times 225 \times 10 = 14,400,000 \text{ inches}$$

It should be noted that the stroke length must be multiplied by 2 because the load is always on the same side of the ball groove during both extend and retract strokes.

HORIZONTAL APPLICATION

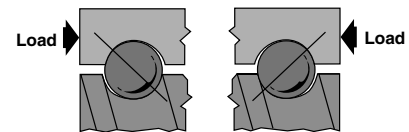

Using the vertical application example it would not be necessary to multiply the 8 inch stroke length by 2 in a horizontal application. The calculation is:

$$8 \times 25 \times 16 \times 225 \times 10 = 7,200,000 \text{ inches}$$

Ball Screw Selection Guide

Once the load and design life objectives have been determined, refer to the load/life relationship formula on page 87 to select the correct unit.

STEP 3. Verify safe speed

The three factors that determine the safe speed of a ball bearing screw are:

- Screw diameter
- Screw length
- Rigidity of end mountings

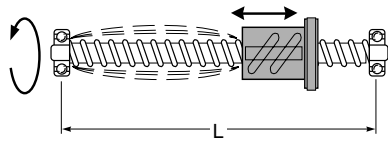

A small diameter, long length screw operating at very high speed could develop severe vibrations. Normally, this is not a problem, but should always be checked.

$$\text{RPM} = \frac{\text{travel rate (inches/minute)}}{\text{lead (inches/revolution)}}$$

If safe speed is a concern, first use the most rigid end mounting arrangement. Secondly, use a larger diameter screw.

Engineering curves for critical speed comparisons of all models can be found on page 86.

STEP 4. Verify safe compression load

The three factors that determine the safe compression load of a given diameter ball bearing screw are:

- Length between load point and end bearing
- Load
- Rigidity of end mountings

If a sufficiently heavy load is applied to a long ball bearing screw it could buckle. The easiest solution to this problem is to use the most rigid end mounting. The next step is to select a larger diameter screw.

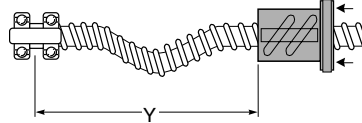

Engineering curves for compression load comparisons of all models can be found on page 88.

End Mounting Bearing Supports

Four combinations of bearing supports are used throughout this catalog for selection purposes. They are:

FIXED (least support) FREE

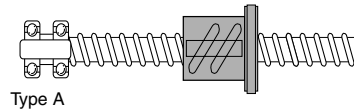

SIMPLE SIMPLE

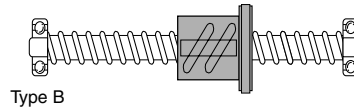

FIXED SIMPLE

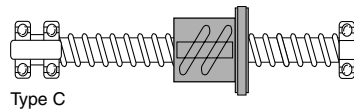

FIXED FIXED

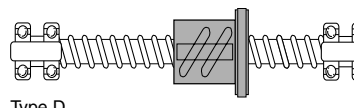

See pages 51 – 60 for more information on end journals and bearing supports.

Other Considerations

In selecting a ball screw, many factors such as load, length, bearing supports, life, speed, etc., are interrelated. Changing one factor often forces the designer to change another. The selection process consists largely of balancing these factors to arrive at the optimum design.

An example of the interrelationship of design factors is fine lead vs. coarse lead. A fine lead provides better positioning sensitivity and a lower drive torque, but it also results in higher rotary speed. A coarse lead results in lower rotary speed, but requires a higher drive torque which may require a larger motor and related drive components. The chart below presents the effect of change in parameters on common ball bearing screw characteristics.

| INCREASE | RESULT |
|-----------------------|--------------------------------|
| Screw Length | Critical Speed decreases |
| | Compression load decreases |
| Screw Diameter | Critical speed increases |
| | Inertia increases |
| Lead | Drive torque increases |
| | Angular velocity decreases |
| End Mounting Rigidity | Critical speed increases |
| | Compression load increases |
| Load | Life decreases |
| Preload | Positioning accuracy increases |
| | System stiffness increases |
| | Drag torque increases |

Precision Rolled 3/8" to 3/4" Diameter

| BALL SCREWS | | | | STANDARD BALL NUTS | | | | | | PRELOADED BALL NUTS | | | | | | |
|-------------|---------------|-------|-------------|-------------------------------|----------------|-----------|-----------|----------|-----------------|----------------------------|--------------------------|----------------------|----------|--------------------|--------------------------|--|
| NOM. DIA. | LEAD (IN/REV) | RH LH | SST 17-4 PH | SUPPORT BEARING (SEE PAGE 51) | NOM. ROOT DIA. | SCREW P/N | NUT P/N | NUT TYPE | NO. OF CIRCUITS | DYNAMIC LOAD RATING (LBS)* | STATIC LOAD RATING (LBS) | TORQUE TO RAISE 1 LB | NUT P/N | MAX. PRELOAD (LBS) | STATIC LOAD RATING (LBS) | |
| 3/8 | .125 | R | | 6mm | .300 | RO308† | RB0308-2 | A | 2 | 500 | 4,250 | | | | | |
| | .125 | R | | | | PRX10† | RX10-2 | D | 1 | 136 | 1,415 | .02 lb-in | | | | |
| | .125 | R | x | | | PRB15 | RB15-2 | D | 1 | 25 | 230 | | | | | |
| 1/2 | .200 | R | | 6mm or 8mm | .390 | PR0505 | RO505-2 | A | 2 | 1,200 | 9,400 | .04 lb-in | RP0505-2 | 360 | 9,040 | |
| | .500 | R | | | | PR0502 | RB20-2 | B | 2 | 850 | 4,150 | .09 lb-in | | | | |
| | .500 | R | x | | | PRB21 | RB21-2 | B | 2 | 140 | 750 | | | | | |
| 5/8 | .200 | R | | 8mm | .480 | PR0605 | RC0605-2 | D | 1 | 800 | 6,150 | | RD0605-2 | 240 | 5,910 | |
| | .200 | R | | | | PR0605 | RQ0605-2 | F | 1 | 800 | 6,150 | | | | | |
| | .200 | L | | | | PRL0605 | RK0605-2 | D | 1 | 800 | 6,150 | .04 lb-in | RE0605-2 | 240 | 5,910 | |
| | .200 | L | | | | PRL0605 | RR0605-2 | F | 1 | 800 | 6,150 | | | | | |
| | .200 | R | x | | | SPRB30 | SRB30-2 | D | 1 | 170 | 1,250 | | | | | |
| | .200 | L | x | | | SPRB31 | SRB31-2 | D | 1 | 170 | 1,250 | | | | | |
| 3/4 | .200 | R | | 12mm | .625 | PR0705 | RBC0705-2 | D | 1 | 950 | 7,750 | | | | | |
| | .200 | R | | | | PR0705 | RB0705-2 | A | 2 | 1,900 | 18,800 | .04 lb-in | | | | |
| | .200 | R | x | | | PRB36 | RB36-2 | D | 1 | 160 | 1,350 | | | | | |
| | .500 | R | | | | PR0702 | RO702-2 | B | 2 | 3,450 | 24,200 | .09 lb-in | RP0702-2 | 1,035 | 23,165 | |
| | .500 | R | x | | | PRS0702 | RS0702-2 | B | 2 | 600 | 3,460 | | | | | |

All screws come in precision grade (0.003 in/ft) except as noted. Delete the leading P in the screw P/N for standard grade (0.010 in/ft.)

Non-preloaded ball nuts come standard with no more than 0.007" backlash. Minimum backlash (0.002") is available for an additional charge. For zero backlash, select a preloaded assembly.

*Dynamic load ratings based on 1,000,000 inches of travel using BSA Grease—see page 80.

†Available only in 0.005" per foot lead accuracy.

Complete assembly selections shown pages 51 – 60.

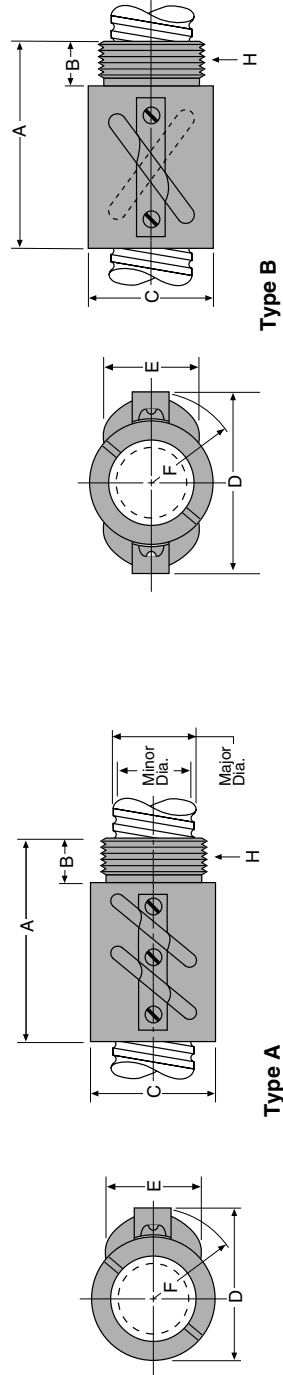

Precision Rolled 3/8" to 3/4" Diameter

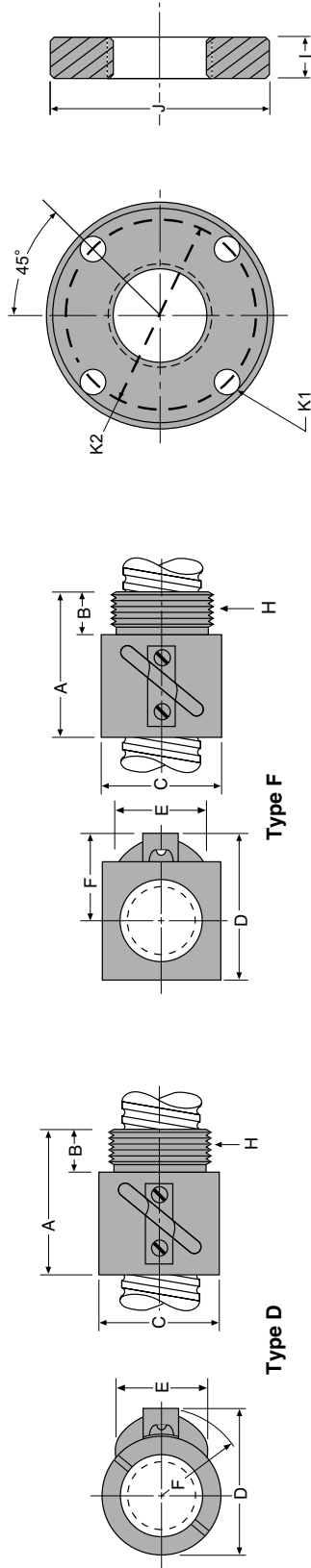

Flange — Type 1

DIMENSIONS

| | | STANDARD BALL NUTS | | | | | | | | | | OPTIONAL BALL NUT FLANGES | | | |
|-----------|----------|--------------------|----------|----------|----------|----------|----------|------------------------|----------|----------|-----------------|------------------------------|--|--|--|
| NUT P/N | NUT TYPE | A MAX | B MAX | C MAX | D MAX | E MAX | F MAX | H "V" THREADS | I MAX | J MAX | K1 HOLE DIA. | K2 BOLT CIRCLE DIA. | | | |
| RB0308-2 | A | 1.83 | 0.255 | 0.786 | 0.915 | 0.468 | 0.55 | .664-32 (N-03 Locknut) | 0.275 | 1.61 | 0.177 (4x) | 1.24 | | | |
| RX10-2 | D | 1.01 | 0.255 | 0.755 | 0.850 | 0.475 | 0.48 | .664-32 (N-03 Locknut) | 0.275 | 1.61 | 0.177 (4x) | 1.24 | | | |
| RB15-2 | D | 1.01 | 0.255 | 0.736 | 0.850 | 0.475 | 0.48 | .664-32 (N-03 Locknut) | 0.275 | 1.61 | 0.177 (4x) | 1.24 | | | |
| RO505-2 | A | 2.76 | 0.390 | 1.070 | 1.339 | 0.665 | 0.85 | 15/16-16 UN-2A | 0.540 | 2.63 | 0.281 (4x) | 2.09 | | | |
| RB20-2 | B | 1.76 | 0.390 | 1.063 | 1.390 | 0.625 | 0.70 | 15/16-16 UN-2A | 0.540 | 2.63 | 0.281 (4x) | 2.09 | | | |
| RB21-2 | B | 1.76 | 0.390 | 1.063 | 1.390 | 0.625 | 0.70 | 15/16-16 UN-2A | 0.540 | 2.63 | 0.281 (4x) | 2.09 | | | |
| RC0605-2 | D | 1.72 | 0.510 | 1.130 | 1.360 | 0.787 | 0.80 | 15/16-16 UN-2A | 0.540 | 2.63 | 0.281 (4x) | 2.09 | | | |
| RQ0605-2 | F | 1.72 | 0.510 | 1.005 | 1.300 | 0.797 | 0.80 | 15/16-16 UN-2A | 0.540 | 2.63 | 0.281 (4x) | 2.09 | | | |
| RK0605-2 | D | 1.72 | 0.510 | 1.130 | 1.360 | 0.787 | 0.80 | 15/16-16 UN-2A | 0.540 | 2.63 | 0.281 (4x) | 2.09 | | | |
| RR0605-2 | F | 1.72 | 0.510 | 1.005 | 1.300 | 0.797 | 0.80 | 15/16-16 UN-2A | 0.540 | 2.63 | 0.281 (4x) | 2.09 | | | |
| SRB30-2 | D | 1.72 | 0.510 | 1.361 | 1.500 | 0.900 | 0.80 | 15/16-16 UN-2A | 0.540 | 2.63 | 0.281 (4x) | 2.09 | | | |
| SRB31-2 | D | 1.72 | 0.510 | 1.361 | 1.500 | 0.900 | 0.80 | 15/16-16 UN-2A | 0.540 | 2.63 | 0.281 (4x) | 2.09 | | | |
| RBC0705-2 | D | 1.89 | 0.510 | 1.317 | 1.550 | 0.959 | 0.90 | 1 1/8-18 UNEF-2A | 0.540 | 2.63 | 0.266 (4x) | 2.09 | | | |
| RB0705-2 | A | 2.89 | 0.510 | 1.317 | 1.521 | 0.917 | 0.94 | 1 1/8-18 UNEF-2A | 0.540 | 2.63 | 0.266 (4x) | 2.09 | | | |
| RB36-2 | D | 1.88 | 0.510 | 1.361 | 1.580 | 0.770 | 0.90 | 1 1/8-18 UNEF-2A | 0.540 | 2.63 | 0.266 (4x) | 2.09 | | | |
| PR702-2 | B | 2.94 | 0.510 | 1.317 | 1.984 | 0.983 | 1.06 | 1 1/4-16 UN-2A | 0.540 | 2.63 | 0.281 (4x) | 2.09 | | | |
| RS0702-2 | B | 2.94 | 0.510 | 1.317 | 1.984 | 0.983 | 1.06 | 1 1/4-16 UN-2A | 0.540 | 2.63 | 0.281 (4x) | 2.09 | | | |

Complete assembly selections shown on pages 51 - 60.

Precision Rolled 3/8" to 3/4" Diameter

DIMENSIONS

| PRELOADED BALL NUTS | | | | | | | | | | OPTIONAL BALL NUT FLANGES | | | |
|---------------------|----------|--------|--------|--------|--------|-------|-------|----------------|-------|---------------------------|--------------|---------------------|--|
| NUT P/N | NUT TYPE | A' MAX | B* MAX | C* MAX | F* MAX | M MAX | N MAX | H* "V" THREADS | I MAX | J MAX | K1 HOLE DIA. | K2 BOLT CIRCLE DIA. | |
| RP0505-2 | A | 5.95 | 0.390 | 1.067 | 0.85 | 1.420 | 0.203 | 15/16-16 UN-2A | 0.540 | 2.63 | 0.281 (4x) | 2.09 | |
| RD0605-2 | D | 3.72 | 0.510 | 1.130 | 0.80 | 1.420 | 0.203 | 15/16-16 UN-2A | 0.540 | 2.63 | 0.281 (4x) | 2.09 | |
| RE0605-2 | D | 3.75 | 0.510 | 1.130 | 0.80 | 1.420 | 0.203 | 15/16-16 UN-2A | 0.540 | 2.63 | 0.281 (4x) | 2.09 | |
| RP0702-2 | B | 6.18 | 0.510 | 1.317 | 1.06 | 1.670 | 0.266 | 1 1/4-16 UN-2A | 0.540 | 2.63 | 0.281 (4x) | 2.09 | |

*See drawings on previous two pages.
Complete assembly selections shown on pages 51 – 60.

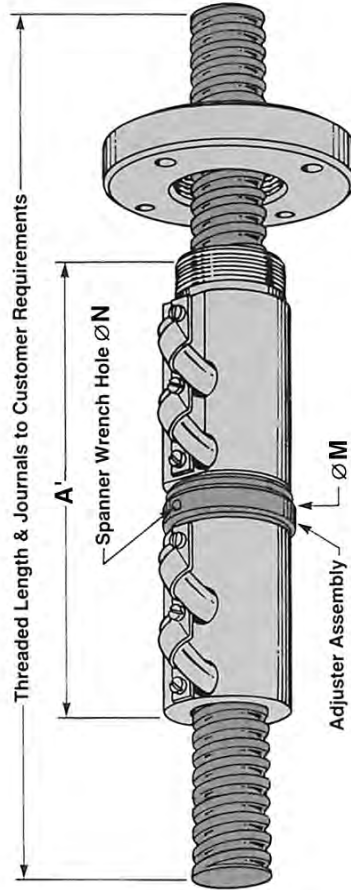

Preloaded Ball Nut

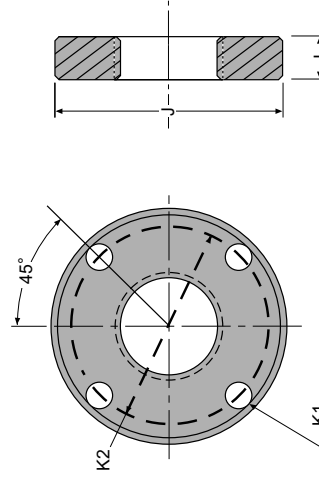

Flange — Type 1

Complete Drive Assemblies

Complete Screw Assemblies

- Any screw we sell complete with end bearings or NEMA motor mounts (pages 51 – 60)
- Made to your length
- No drawings required
- Quick delivery

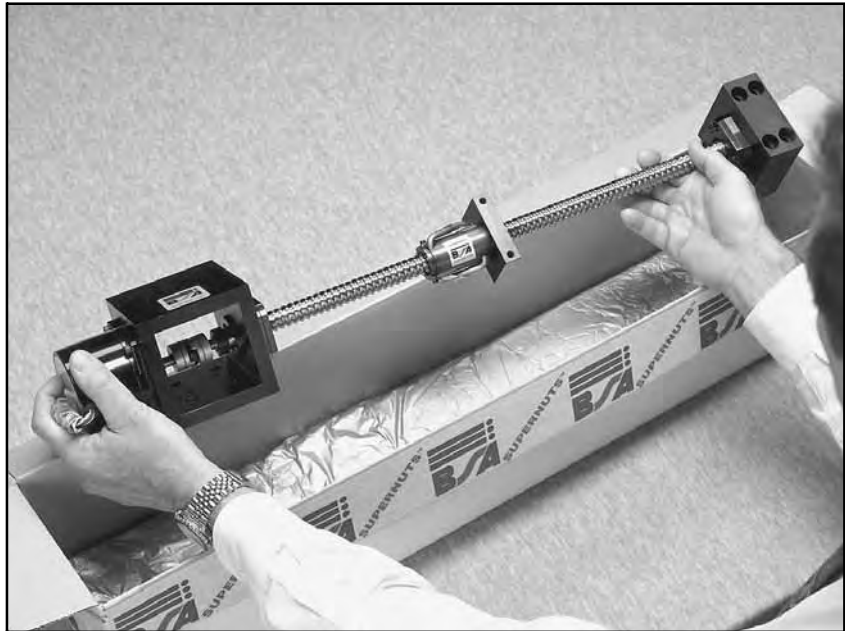

Complete Selection of Components

- Acme screws & Supernuts™ —1/8" to 3" diameter (pages 7 – 28)
- Ball screws—4mm to 4" diameter (pages 29 – 49)
- End Bearings (pages 51 – 60)
- Flanges, wiper kits, and couplings (pages 77 – 83)
- Specially formulated greases (page 80)

**COMPLETE ASSEMBLY SELECTIONS
SHOWN ON PAGES 51 – 60.**

Precision Rolled 1" to 1-1/2" Diameter

| BALL SCREWS | | | | | STANDARD BALL NUTS | | | | | PRELOADED BALL NUTS | | | | | |
|-------------|---------------|-------|-------------------------------|----------------|--------------------|----------|----------|-----------------|----------------------------|--------------------------|-------------------------|----------|--------------------|--------------------------|--|
| NOM. DIA. | LEAD (IN/REV) | RH LH | SUPPORT BEARING (SEE PAGE 51) | NOM. ROOT DIA. | SCREW P/N | NUT P/N | NUT TYPE | NO. OF CIRCUITS | DYNAMIC LOAD RATING (LBS)* | STATIC LOAD RATING (LBS) | TORQUE TO RAISE TO 1 LB | NUT P/N | MAX. PRELOAD (LBS) | STATIC LOAD RATING (LBS) | |
| 1 | 0.250 | R | 15 or 20mm | 0.836 | PR1004 | R1004-2 | A | 2 | 3,350 | 30,750 | | | | | |
| | 0.250 | R | | | PR1004 | RC1004-2 | D | 1 | 1,600 | 12,700 | .05 lb-in | | | | |
| | 0.250 | L | | | PRL1004 | RL1004-2 | A | 2 | 3,350 | 30,750 | | | | | |
| | 0.250 | L | | | PRL1004 | RK1004-2 | D | 1 | 1,600 | 12,700 | | | | | |
| 1 1/8 | 0.500 | R | 20mm | 0.879 | PR1002 | R1002-2 | B | 2 | 3,950 | 32,300 | .09 lb-in | RP1002-2 | 1,185 | 31,115 | |
| | 1.000 | R | | | PR1001 | R1001-2 | B | 2 | 2,250 | 13,750 | .18 lb-in | | | | |
| | 1.000 | R | | | RS1001† | RS1001-2 | B | 2 | 430 | 2,000 | | | | | |
| 1 1/2 | 0.200 | R | 25mm | 1.020 | PR1105 | R1105-2 | A | 2 | 2,400 | 27,550 | .04 lb-in | RP1105-2 | 720 | 26,830 | |
| | 0.250 | R | | | PRX1504† | RX1504-2 | A | 2 | 4,198 | 44,030 | .05 lb-in | | | | |
| | 0.500 | R | | | PR1502 | R1502-2 | A | 2 | 12,900 | 102,300 | .09 lb-in | RP1502-2 | 3,870 | 98,430 | |
| | 0.500 | L | | | PRL1502 | RL1502-2 | A | 2 | 12,900 | 102,300 | | | | | |
| | 1.000 | R | | | PR1501 | R1501-2 | B | 2 | 8,250 | 47,800 | .18 lb-in | RP1501-2 | 2,475 | 45,325 | |
| | 2.000 | R | | 1.210 | PR1520 | R1520-2 | B | 2 | 7,600 | 29,000 | .35 lb-in | | | | |

All screws come standard in precision grade (0.003 in/ft) except where noted. Delete the leading P in the screw P/N for standard grade (0.010 in/ft)

One-inch nuts come with up to 0.009" backlash. Larger sizes come standard with up to 0.018" backlash. Custom loading is available. For zero backlash select a preloaded assembly.

*Dynamic load ratings based on 1,000,000 inches of travel using BSA grease—see page 80.

†Offered in 0.005 in/ft grade only.

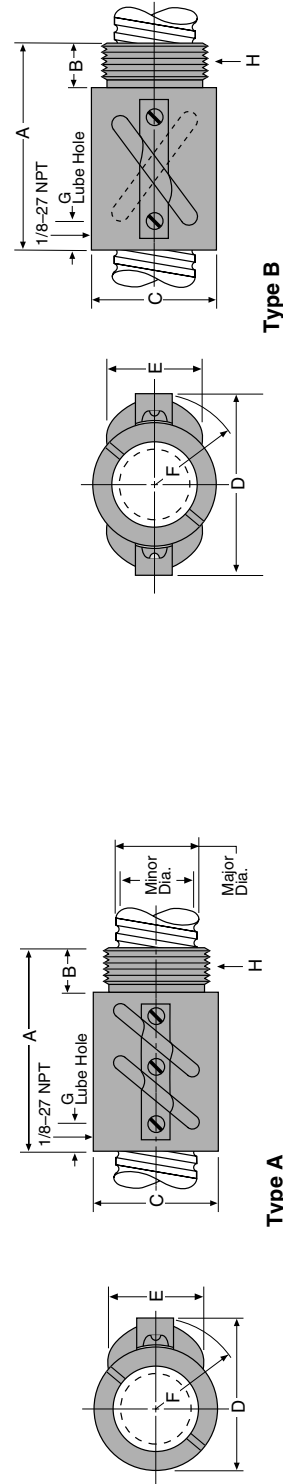

Precision Rolled 1" to 1-1/2" Diameter



Flange — Type 1

Type D

DIMENSIONS

| | | STANDARD BALL NUTS | | | | | | | | | | OPTIONAL BALL NUT FLANGES | | | | |
|----------|----------|--------------------|----------|----------|----------|----------|----------|-----------|-------------------|----------------|----------|---------------------------|--------------------|------------------------------|--|--|
| NUT P/N | NUT TYPE | A MAX | B MAX | C MAX | D MAX | E MAX | F MAX | G MAX* | H “V” THREADS | FLANGE TYPE | I MAX | J MAX | K1 HOLE DIA. | K2 BOLT CIRCLE DIA. | | |
| R1004-2 | A | 3.14 | 0.630 | 1.692 | 1.882 | 1.191 | 1.12 | - | 1 9/16-18 UNEF-2A | 1 | 0.640 | 3.28 | 0.281 | 2.75 | | |
| RC1004-2 | D | 2.36 | 0.630 | 1.692 | 1.913 | 1.185 | 1.09 | - | 1 9/16-18 UNEF-2A | 1 | 0.640 | 3.28 | 0.281 | 2.75 | | |
| RL1004-2 | A | 3.14 | 0.630 | 1.692 | 1.882 | 1.191 | 1.05 | - | 1 9/16-18 UNEF-2A | 1 | 0.640 | 3.28 | 0.281 | 2.75 | | |
| RK1004-2 | D | 2.36 | 0.630 | 1.692 | 1.913 | 1.185 | 1.08 | - | 1 9/16-18 UNEF-2A | 1 | 0.640 | 3.28 | 0.281 | 2.75 | | |
| R1002-2 | B | 3.13 | 0.630 | 1.692 | 2.172 | 1.191 | 1.12 | - | 1 9/16-18 UNEF-2A | 1 | 0.640 | 3.28 | 0.281 | 2.75 | | |
| R1001-2 | B | 3.10 | 0.605 | 1.692 | 2.172 | 1.200 | 1.17 | - | 1 9/16-18 UNEF-2A | 1 | 0.640 | 3.28 | 0.281 | 2.75 | | |
| RS1001-2 | B | 3.10 | 0.605 | 1.692 | 2.172 | 1.200 | 1.10 | - | 1 9/16-18 UNEF-2A | 1 | 0.640 | 3.28 | 0.281 | 2.75 | | |
| R1105-2 | A | 2.51 | 0.485 | 1.692 | 1.963 | 1.281 | 1.22 | - | 1 5/8-20 UN-2A | 1 | 0.495 | 3.23 | 0.281 | 2.702 | | |
| RX1504-2 | A | 2.88 | 0.505 | 2.098 | 2.400 | 1.604 | 1.53 | - | 1.967-18 UNS-2A | 1 | 0.520 | 4.20 | 0.397 | 3.440 | | |
| R1502-2 | A | 5.59 | 0.755 | 2.630 | 3.177 | 1.564 | 1.93 | .46 | 2.360-18 UNS-2A | 1 | 0.785 | 4.65 | 0.531 | 3.875 | | |
| RL1502-2 | A | 5.59 | 0.755 | 2.630 | 3.154 | 1.566 | 1.88 | .46 | 2.360-18 UNS-2A | 1 | 0.785 | 4.65 | 0.531 | 3.875 | | |
| R1501-2 | B | 3.65 | 1.010 | 2.630 | 3.696 | 1.737 | 1.96 | - | 2 1/4-20 UN-2A | 1 | 1.030 | 4.97 | 0.531 | 4.125 | | |
| R1520-2 | B | 5.26 | 1.005 | 2.621 | 3.400 | 1.576 | 1.68 | .50 | 2 1/4-20 UN-2A | 1 | 1.030 | 4.97 | 0.531 | 4.125 | | |

* Lube hole is 1/8 - 27 NPT tapped hole where offered.

Precision Rolled 1" to 1-1/2" Diameter

DIMENSIONS

| PRELOADED BALL NUTS | | | | | | | | | | OPTIONAL BALL NUT FLANGES | | | | |
|---------------------|----------|--------|--------|--------|--------|---------|-------|-------|-------------------|---------------------------|-------|-------|--------------|---------------------|
| NUT P/N | NUT TYPE | A' MAX | B* MAX | C* MAX | F* MAX | G*† MAX | M MAX | N MAX | H* "V" THREADS | FLANGE TYPE | I MAX | J MAX | K1 HOLE DIA. | K2 BOLT CIRCLE DIA. |
| RPI002-2 | B | 6.64 | 0.630 | 1.692 | 1.12 | - | 2.070 | .266 | 1 9/16-18 UNEF-2A | 1 | 0.640 | 3.28 | 0.281 | 2.75 |
| RPI105-2 | A | 5.50 | 0.485 | 1.692 | 1.22 | - | 2.070 | .266 | 1 5/8-20 UN-2A | 1 | 0.495 | 3.23 | 0.281 | 2.702 |
| RPI502-2 | A | 12.10 | 0.755 | 2.630 | 1.93 | .46 | 3.114 | .437 | 2.360-18 UNS-2A | 1 | 0.785 | 4.65 | 0.531 | 3.875 |
| RPI501-2 | B | 8.16 | 1.010 | 2.630 | 1.96 | - | 3.114 | .437 | 2 1/4-20 UN-2A | 1 | 1.030 | 4.97 | 0.531 | 4.125 |

* See drawings on the two previous pages.

† Lube hole is 1/8 -27 NPT tapped hole where offered.

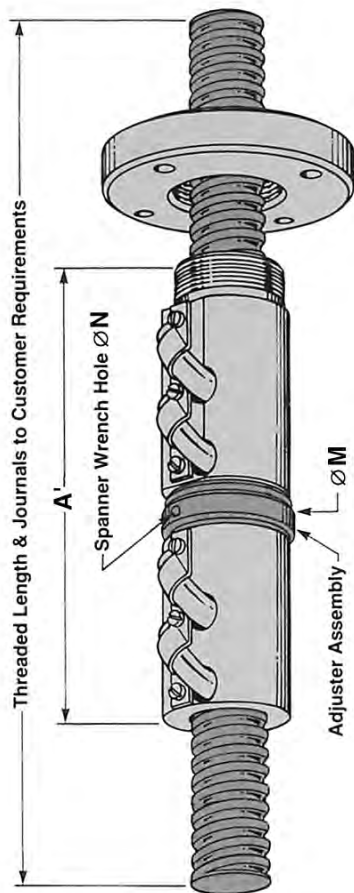

Preloaded Ball Nut

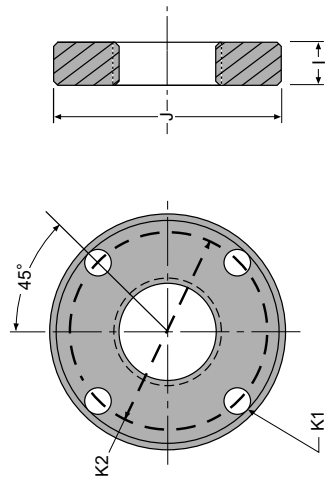

Flange — Type 1



Metric Lead Screws Now Available

High Performance Lead Screw Assemblies

- Complete line of metric lead screws & nuts — 28 sizes offered
- Leads from 2 to 45mm
- Diameters from 10 to 24mm
- Available XC Nut Technology with ActiveCAM®
- Bearing Grade Polymer Nuts with Stainless Steel Screws
- Metric Thread or Flange Mount on all Nuts
- Go to www.danahermotion.com/documents and click on
- Ball & Lead Screws for PDF catalog download

Precision Rolled 2" to 4" Diameter

| BALL SCREWS | | | | | | STANDARD BALL NUTS | | | | | | PRELOADED BALL NUTS | | | |
|-------------|---------------|-------|-----|------------------------------------|----------------|--------------------|----------|----------|-----------------|----------------------------|--------------------------|----------------------|----------|--------------------|--------------------------|
| NOM. DIA. | LEAD (IN/REV) | RH LH | SST | SUG. SUPPORT BEARING (SEE PAGE 51) | NOM. ROOT DIA. | SCREW P/N | NUT P/N | NUT TYPE | NO. OF CIRCUITS | DYNAMIC LOAD RATING (LBS)* | STATIC LOAD RATING (LBS) | TORQUE TO RAISE 1 LB | NUT P/N | MAX. PRELOAD (LBS) | STATIC LOAD RATING (LBS) |
| 2 | 0.500 | R | | | 1.723 | PR2002 | R2002-2 | A | 2 | 18,500 | 143,400 | .09 lb-in | RP2002-2 | 5,245 | 150,805 |
| | 0.500 | L | | 35mm | | RL2002 | RL2002-2 | A | 2 | 18,500 | 143,400 | | RT2002-2 | 5,245 | 150,805 |
| | 1.000 | R | | | | PR2001 | R2001-2 | B | 2 | 21,200 | 134,500 | .18 lb-in | RP2001-2 | 6,585 | 148,215 |
| 2 1/4 | 0.500 | R | | 40mm | 1.850 | PRX2202† | RX2202-2 | A | 2 | 21,306 | 142,660 | .09 lb-in | — | — | — |
| 2 1/2 | 0.250 | R | | | 2.320 | PRX74‡ | RX74-2 | C | 3 | 6,315 | 81,938 | .05 lb-in | — | — | — |
| | 0.500 | R | | — | 2.222 | PR2502 | R2502-2 | A | 2 | 21,200 | 186,000 | .09 lb-in | — | — | — |
| | 1.000 | R | | | | PR2501 | R2501-2 | B | 2 | 27,000 | 174,000 | .18 lb-in | — | — | — |
| 3 | 0.660 | R | | — | 2.483 | PR3066 | R3066-2 | C | 3 | 34,200 | 320,150 | .12 lb-in | — | — | — |

All screws come standard in precision grade (0.003 in/ft). Delete the leading P in the screw P/N for standard grade (0.010 in/ft)

One-inch nuts come with 0.009" backlash. Larger sizes come standard with up to 0.018" backlash. Custom loading is available. For zero backlash select a preloaded assembly.

*Dynamic load ratings based on 1,000,000 inches of travel using BSA grease—see page 80.

†Offered in 0.004" grade only.

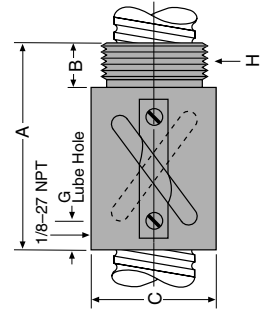

Type B

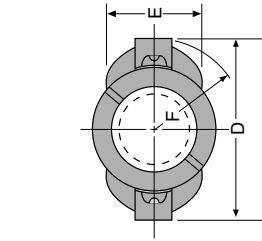

Type A

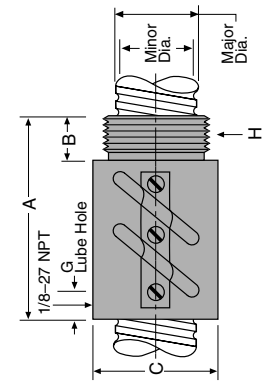

Precision Rolled 2" to 4" Diameter

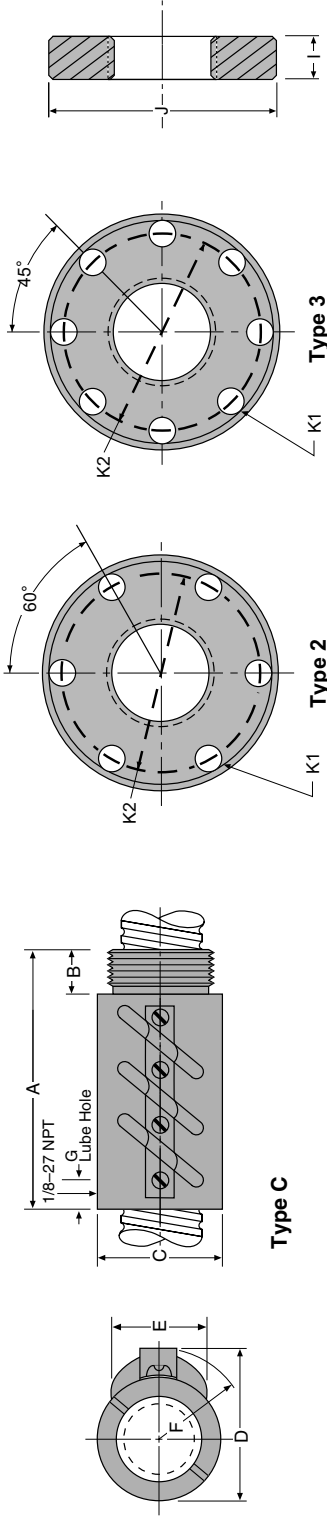

Flanges

DIMENSIONS

| NUT P/N | NUT TYPE | STANDARD BALL NUTS | | | | | | | | | | OPTIONAL BALL NUT FLANGES | | | | |
|----------|----------|--------------------|-------|-------|-------|-------|-------|--------|-----------------|-------------|-------|---------------------------|--------------|---------------------|--|--|
| | | A MAX | B MAX | C MAX | D MAX | E MAX | F MAX | G MAX* | H "V" THREADS | FLANGE TYPE | I MAX | J MAX | K1 HOLE DIA. | K2 BOLT CIRCLE DIA. | | |
| R2002-2 | A | 6.41 | 1.505 | 3.255 | 3.861 | 2.010 | 2.27 | .50 | 3-12 UN-2A | 3 | 1.536 | 5.41 | 0.656 | 4.25 | | |
| RL2002-2 | A | 6.41 | 1.505 | 3.255 | 3.861 | 2.010 | 2.27 | .50 | 3-12 UN-2A | 3 | 1.536 | 5.41 | 0.656 | 4.25 | | |
| R2001-2 | B | 6.41 | 1.505 | 3.255 | 4.460 | 2.330 | 2.29 | .50 | 3-12 UN-2A | 3 | 1.536 | 5.41 | 0.656 | 4.25 | | |
| RX2202-2 | A | 6.70 | 1.570 | 3.380 | 3.960 | 2.561 | 2.48 | — | 3.137-12 UNS-2A | 2 | 1.587 | 5.41 | 0.656 | 4.375 | | |
| RX74-2 | C | 3.76 | 0.755 | 3.380 | 3.725 | 2.306 | 2.02 | — | 3.34-12 | 2 | 0.775 | 5.38 | 0.656 | 4.375 | | |
| R2502-2 | A | 6.78 | 1.755 | 4.005 | 4.640 | 2.371 | 2.77 | .50 | 3 5/8-12 UN-2A | 3 | 1.785 | 6.03 | 0.656 | 5.00 | | |
| R2501-2 | B | 6.78 | 1.755 | 4.005 | 5.274 | 2.381 | 2.66 | .50 | 3 5/8-12 UN-2A | 3 | 1.785 | 6.03 | 0.656 | 5.00 | | |
| R3066-2 | C | 9.35 | 2.010 | 4.755 | 5.486 | 3.356 | 3.34 | .50 | 4.325-12 UNS-2A | 3 | 2.025 | 7.41 | 0.781 | 6.25 | | |

* Lube hole is 1/8 - 27 NPT tapped hole where offered.

Precision Rolled 2" to 4" Diameter

DIMENSIONS

| PRELOADED BALL NUTS | | | | | | | | | | OPTIONAL BALL NUT FLANGES | | | | |
|---------------------|----------|--------|--------|--------|--------|---------|-------|-------|----------------|---------------------------|-------|-------|--------------|---------------------|
| NUT P/N | NUT TYPE | A' MAX | B* MAX | C* MAX | F* MAX | G*† MAX | M MAX | N MAX | H* "V" THREADS | FLANGE TYPE | I MAX | J MAX | K1 HOLE DIA. | K2 BOLT CIRCLE DIA. |
| RP2002-2 | A | 13.92 | 1.505 | 3.255 | 2.27 | .50 | 3.710 | .500 | 3-12 UN-2A | 3 | 1.536 | 5.41 | 0.656 | 4.25 |
| RT2002-2 | A | 13.92 | 1.505 | 3.255 | 2.27 | .50 | 3.710 | .500 | 3-12 UN-2A | 3 | 1.536 | 5.41 | 0.656 | 4.25 |
| RP2001-2 | B | 13.90 | 1.505 | 3.255 | 2.29 | .50 | 3.710 | .500 | 3-12 UN-2A | 3 | 1.536 | 5.41 | 0.656 | 4.25 |

* See drawings on previous two pages.

† Lube hole is 1/8"-27 NPT tapped hole where offered.

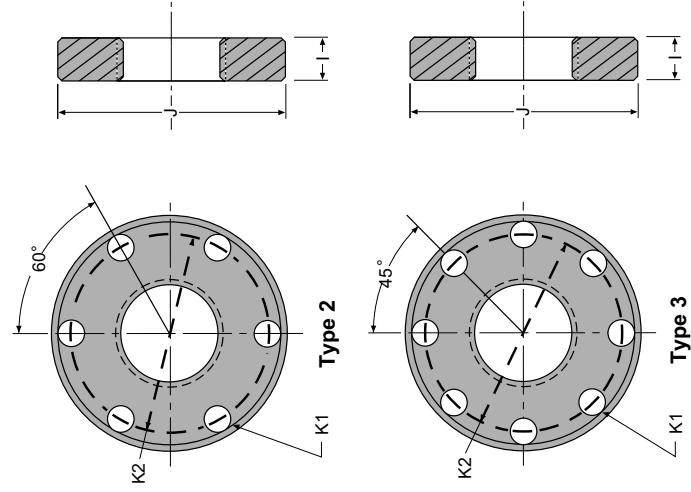

Flanges

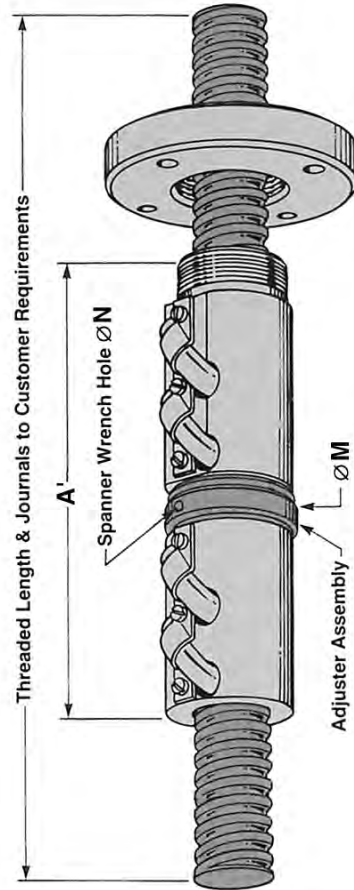

Preloaded Ball Nut

Miniature Rolled Ball Screw Assemblies

Overview

- Smooth and efficient
- Wide selection of leads available
- Small envelope
- Designed for a cost effective solution



Material

| ITEM | MATERIAL | HEAT PROCESSING | HARDNESS |
|-------------|------------|--------------------|-----------|
| Screw Shaft | 4150 Steel | Induction Hardened | HRC 58-62 |
| Nut | 4150 Steel | Carbuerized | HRC 58-62 |

Screw Length Availability

| SHAFT DIAMETER | MAXIMUM LENGTH |
|----------------|----------------|
| 4 mm | 100 mm |
| 6 mm | 200 mm |
| 8 mm | 400 mm |
| 10 mm | 400 mm |
| 12 mm | 700 mm |
| 13 mm | 700 mm |
| 14 mm | 700 mm |

Screw Precision and Axial Play

| SCREW DIAMETER | ACCURACY | AXIAL BACKLASH |
|----------------|----------|----------------|
| 4 to 10 mm | C7 | 20 microns |
| 12 to 14 mm | C10 | 50 microns |

C7 = less than .002"/foot, C10 = less than .009"/foot.

Precision Rolled 4mm to 14mm Diameter

Type A

Because of the ball recirculating mechanism of the end cap type, the nut length is kept short and the nut diameter is kept to a minimum. Moreover, there are flat flanges in two places and the height is low, making a compact structure, with very smooth movement.

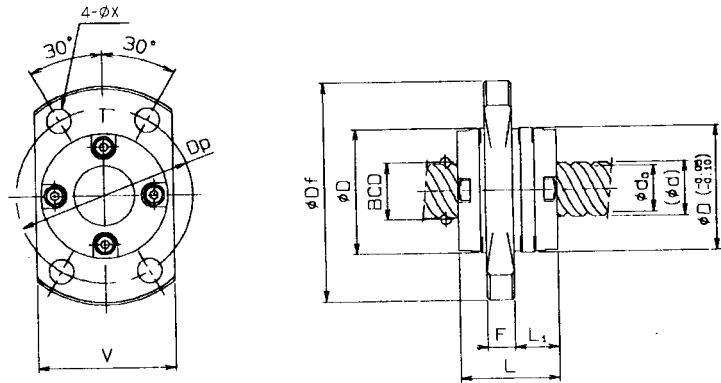

| MODEL NUMBER | SCREW SHAFT OD (MM) | LEAD (MM) | BALL DIA. (MM) | BEARING SUPPORT (SEE PAGE 51) | ROOT DIA. (MM) | LOAD RATING (KG) | |
|--------------|---------------------------|--------------|-------------------|--|-------------------|------------------|--------------|
| | | | | | | CA (DYNAMIC) | CoA (STATIC) |
| PRM0401 | 4 | 1 | 0.8 | NA | 3.3 | 56 | 79 |
| PRM0504 | 5 | 4 | 0.8 | NA | 4.3 | 47 | 72 |
| PRM0601 | 6 | 1 | 0.8 | 4mm | 5.3 | 58 | 120 |
| PRM0606 | | 6 | 1.0 | 4mm | 5.2 | 87 | 145 |
| PRM0801 | 8 | 1 | 0.8 | 6mm | 7.3 | 78 | 165 |
| PRM0802 | | 2 | 1.59 | 6mm | 6.6 | 240 | 410 |
| PRM0805 | | 5 | 1.59 | 6mm | 6.6 | 185 | 300 |
| PRM0808 | | 8 | 1.59 | 6mm | 6.7 | 220 | 380 |
| PRM0812 | | 12 | 1.59 | 6mm | 6.7 | 220 | 400 |
| PRM1002 | 10 | 2 | 1.59 | 6mm | 8.6 | 270 | 530 |
| PRM1010 | | 10 | 2.0 | 6mm | 8.4 | 330 | 590 |
| PRM1015 | | 15 | 2.0 | 6mm | 8.4 | 330 | 640 |
| PRM1020 | | 20 | 1.59 | 6mm | 8.7 | 210 | 400 |
| PRM1202 | 12 | 2 | 1.59 | 8mm | 10.6 | 300 | 640 |
| PRM1312 | 13 | 12 | 2.38 | 8mm | 11.0 | 500 | 990 |
| PRM1320 | | 20 | 2.38 | 8mm | 11.0 | 500 | 1070 |
| PRM1402 | 14 | 2 | 1.59 | 8mm | 12.6 | 320 | 750 |
| PRM1404 | | 4 | 2.38 | 8mm | 11.8 | 570 | 1160 |

Please contact us to find out the sizes to be made in the future or if you want a size not listed above.

Units in millimeters. Divide by 25.4 to get inches.

1 kg = 2.205 lbs

Precision Rolled 4mm to 14mm Diameter

Type B

The steel balls get scooped up by a coil-type deflector inside the nut and are recirculated along a return plate groove. The advantage is that the diameter of the nut can be made smaller than with the tube type, and smoother operations result.

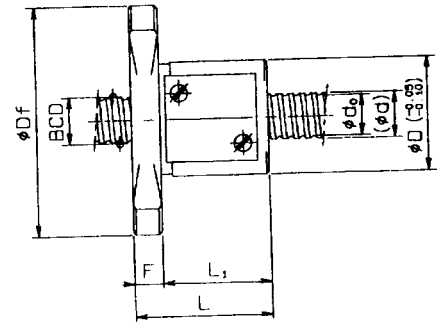
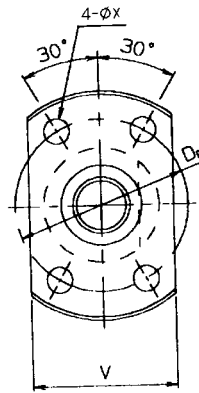

| TYPE | NUT SIZE | | | | | | | | MODEL NUMBER |
|------|-------------------------|---------------------------------|-----------------------|---------------------|--------|--------|-------------|--------------------|--------------|
| | OUTSIDE DIAMETER D (MM) | FLANGE OUTSIDE DIAMETER DF (MM) | OVERALL LENGTH L (MM) | L ₁ (MM) | F (MM) | V (MM) | BCD DP (MM) | MOUNTING HOLE (MM) | |
| B | 11 | 24 | 17 | 13 | 4 | 15 | 18 | 3.4 | PRM0401 |
| B | 12 | 24 | 22 | 18 | 4 | 16 | 18 | 3.4 | PRM0504 |
| B | 13 | 26 | 17 | 13 | 4 | 16 | 20 | 3.4 | PRM0601 |
| A | 14 | 27 | 17 | 8 | 4 | 16 | 21 | 3.4 | PRM0606 |
| B | 16 | 29 | 17 | 13 | 4 | 18 | 23 | 3.4 | PRM0801 |
| B | 20 | 37 | 24 | 19 | 5 | 22 | 29 | 4.5 | PRM0802 |
| B | 18 | 31 | 28 | 24 | 4 | 20 | 25 | 3.4 | PRM0805 |
| A | 18 | 31 | 20 | 10 | 4 | 20 | 25 | 3.4 | PRM0808 |
| A | 18 | 31 | 27 | 17 | 4 | 20 | 25 | 3.4 | PRM0812 |
| B | 23 | 40 | 24 | 19 | 5 | 25 | 32 | 4.5 | PRM1002 |
| A | 23 | 40 | 24 | 13 | 5 | 25 | 32 | 4.5 | PRM1010 |
| A | 23 | 40 | 33 | 22 | 5 | 25 | 32 | 4.5 | PRM1015 |
| A | 20 | 37 | 23 | 13 | 5 | 22 | 29 | 4.5 | PRM1020 |
| B | 25 | 42 | 24 | 19 | 5 | 27 | 34 | 4.5 | PRM1202 |
| A | 28 | 45 | 30 | 17 | 5 | 30 | 37 | 4.5 | PRM1312 |
| A | 28 | 45 | 43 | 29 | 5 | 30 | 37 | 4.5 | PRM1320 |
| B | 26 | 45 | 25 | 19 | 6 | 28 | 36 | 5.5 | PRM1402 |
| B | 30 | 49 | 33 | 27 | 6 | 32 | 40 | 5.5 | PRM1404 |

Units in millimeters. Divide by 25.4 to get inches.

Precision Ground Ball Screw Assemblies

Overview

- Finest Ball Screw Assemblies Available
- Lead Accuracy of .0005"/ft. or better
- Zero Backlash Preloaded Ball Nuts
- Extremely Smooth Operation
- High Axial Stiffness
- Integral Wipers

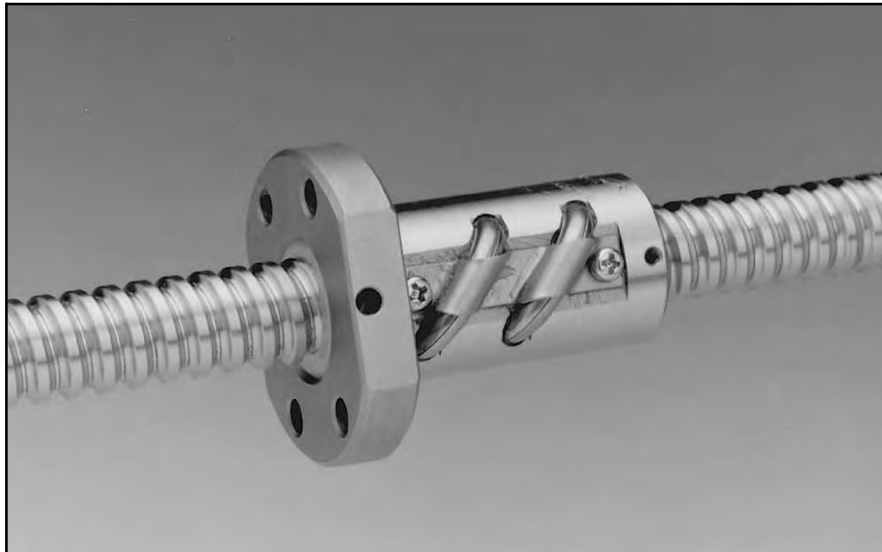

Ground Ball Screw Assemblies are your answer to the most rigorous positioning requirements. With lead accuracies below 0.0005"/ft and repeatability in the microns, our ground assemblies offer a no compromise solution for your application. These units come in a wide variety of diameters and leads (up to 50mm).

Precision Ground 16mm to 38mm Diameter

INCH LEADS

| SCREW DIA. S | LEAD (R.H.) | STROKE (IN) | ASSEMBLY PART NO. | BEARING SIZE | SHAFT DIMENSIONS | | | | BALL NUT DIMENSIONS | | | | | | | | | | LOAD RATING | | PRE-LOAD (LBS.) | DRAG TORQUE (LBS./IN.) |
|--------------|-------------|-------------|-------------------|--------------|------------------|-----------------|------------|--------------|---------------------|----------|--------|-------------|--------------|--------|-------------|-------------|-------------|-----------------|---------------|-----|-----------------|------------------------|
| | | | | | THREAD LENGTH L1 | TOTAL LENGTH L2 | END DIA. E | SMALL END L3 | LARGE END L4 | LENGTH L | DIA. D | FLG. DIA. F | FLG. WIDTH W | FLG. X | B.C. DIA. M | TUBE RAD. R | HOLE SIZE H | DYNA-MIC (LBS.) | STATIC (LBS.) | | | |
| .630 | .200 | 12 | W1603 | 12mm | 14.64 | 22.51 | .520 | 1.97 | 5.90 | 2.237 | 1.092 | 1.930 | .375 | 1.625 | 1.500 | .790 | .219 | 990 | 6,250 | 90 | 0.5 to 1.8 | |
| | | 18 | W1605 | | 20.64 | 28.51 | .677 | 1.97 | 5.90 | 2.237 | 1.092 | 1.930 | .375 | 1.625 | 1.500 | .790 | .219 | 990 | 6,250 | 90 | | |
| | | 24 | W1606 | | 26.64 | 34.51 | | | | | | | | | | | | | | | | |
| | | 36 | W1609 | | 38.64 | 46.51 | | | | | | | | | | | | | | | | |
| 12 | W2003 | 14.72 | 22.59 | .874 | .394 | 7.87 | | | | | | | | | | | | | | | 2.283 | 1.500 |
| 18 | W2005 | 20.72 | 28.59 | | | | | | | | | | | | | | | | | | | |
| 24 | W2006 | 26.72 | 34.59 | | | | | | | | | | | | | | | | | | | |
| 36 | W2009 | 38.72 | 46.59 | | | | | | | | | | | | | | | | | | | |
| .787 | .200 | 24 | W2506 | 20mm | 26.68 | 38.49 | 1.150 | 3.94 | 11.81 | 2.683 | 1.813 | 3.125 | .500 | 2.375 | 2.500 | 1.142 | .344 | 2,100 | 17,500 | 210 | 1.3 to 3.3 | |
| | | 30 | W2508 | | 32.68 | 44.49 | | | | | | | | | | | | | | | | |
| | | 36 | W2509 | | 36.68 | 50.49 | | | | | | | | | | | | | | | | |
| | | 24 | W3206 | | 27.10 | 42.85 | | | | | | | | | | | | | | | | 75.10 |
| 36 | W3210 | 39.10 | 54.85 | | | | | | | | | | | | | | | | | | | |
| 48 | W3213 | 51.10 | 66.85 | | | | | | | | | | | | | | | | | | | |
| 72 | W3219 | 75.10 | 90.85 | | | | | | | | | | | | | | | | | | | |
| 1.260 | .200 | 36 | W3810 | 20 or 25mm | 39.41 | 63.01 | 1.380 | 5.90 | 17.70 | 3.008 | 2.125 | 3.440 | .625 | 2.625 | 2.813 | 1.250 | .344 | 2,500 | 22,100 | 250 | 1.5 to 3.6 | |
| | | 48 | W3813 | | 51.41 | 75.01 | | | | | | | | | | | | | | | | |
| | | 60 | W3816 | | 63.41 | 87.01 | | | | | | | | | | | | | | | | |
| | | 72 | W3819 | | 75.41 | 99.01 | | | | | | | | | | | | | | | | |
| 1.496 | .200 | 36 | W3810 | 20 or 25mm | 39.41 | 63.01 | 1.380 | 5.90 | 17.70 | 3.008 | 2.125 | 3.440 | .625 | 2.625 | 2.813 | 1.250 | .344 | 2,500 | 22,100 | 250 | 1.5 to 3.6 | |
| | | 48 | W3813 | | 51.41 | 75.01 | | | | | | | | | | | | | | | | |
| | | 60 | W3816 | | 63.41 | 87.01 | | | | | | | | | | | | | | | | |
| | | 72 | W3819 | | 75.41 | 99.01 | | | | | | | | | | | | | | | | |

All screws on this page .0003 inches per foot accuracy.

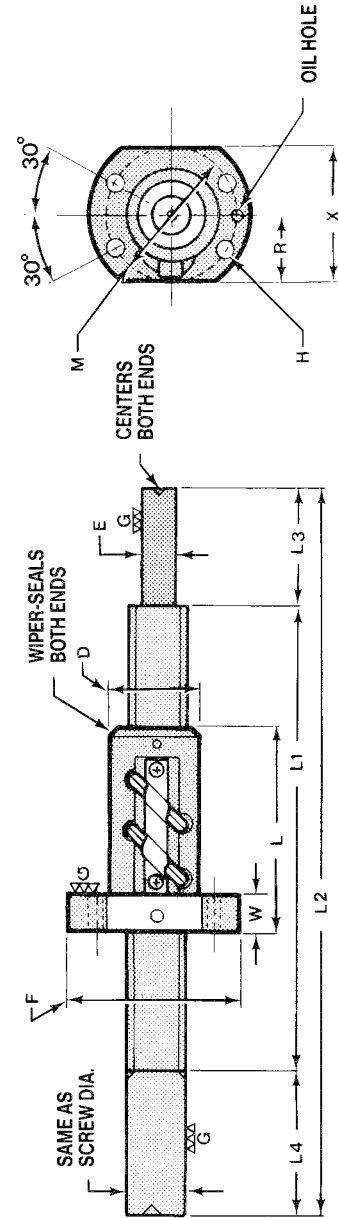

Precision Ground 25mm to 50mm Diameter

INCH LEADS

| SCREW DIA. S | LEAD (R.H.) | STROKE (IN) | ASSEMBLY PART NO. | BEARING SIZE | SHAFT DIMENSIONS | | | | BALL NUT DIMENSIONS | | | | | | | | | | LOAD RATING | | DRAG TORQUE (LBS./IN.) |
|--------------|-------------|-------------|-------------------|--------------|------------------|-----------------|------------|--------------|---------------------|----------|--------|-------------|--------------|--------------|-------------|-------------|-------------|----------------|---------------|-----------------|------------------------|
| | | | | | THREAD LENGTH L1 | TOTAL LENGTH L2 | END DIA. E | SMALL END L3 | LARGE END L4 | LENGTH L | DIA. D | FLG. DIA. F | FLG. WIDTH W | FLG. FLATS X | B.C. DIA. M | TUBE RAD. R | HOLE SIZE H | DYNAMIC (LBS.) | STATIC (LBS.) | PRE-LOAD (LBS.) | |
| .984 | .200 | 42 | W2511D | 20mm | 59.00 | .874 | 4.45 | 7.87 | 4.251 | 1.625 | 2.630 | .500 | 1.062 | 2.125 | 1.000 | .281 | 2,130 | 18,000 | 200 | .09 to 2.4 | |
| | | 60 | W2516D | | 77.00 | | | | | | | | | | | | | | | | |
| 1.496 | .200 | 48 | W3813D | 20 or 25mm | 77.60 | 1.380 | 5.90 | 17.70 | 5.576 | 2.312 | 3.440 | .625 | 1.312 | 2.813 | 1.250 | .344 | 3,980 | 44,200 | 350 | 1.8 to 3.9 | |
| | | 72 | W3819D | | 101.60 | | | | | | | | | | | | | | | | |
| 1.496 | .250 | 48 | W3814D | 20 or 25mm | 79.60 | 1.350 | 5.90 | 17.70 | 6.715 | 2.375 | 3.680 | .625 | 1.375 | 3.000 | 1.350 | .406 | 5,300 | 54,000 | 450 | 2.6 to 5.4 | |
| | | 72 | W3820D | | 103.60 | | | | | | | | | | | | | | | | |
| 1.968 | .200 | 72 | W5020D | 20 or 25mm | 103.60 | 1.850 | 5.90 | 17.70 | 6.335 | 2.812 | 3.940 | .625 | 1.600 | 3.313 | 1.520 | .344 | 3,950 | 46,800 | 350 | 2.0 to 4.4 | |
| | | 96 | W5027D | | 130.10 | 1.700 | | | | 9.435 | 3.312 | 5.380 | .750 | 2.062 | 4.313 | 2.000 | .531 | 12,800 | 97,600 | 1,000 | 10.6 to 19.0 |

All screws on this page .0003 inches per foot lead accuracy.

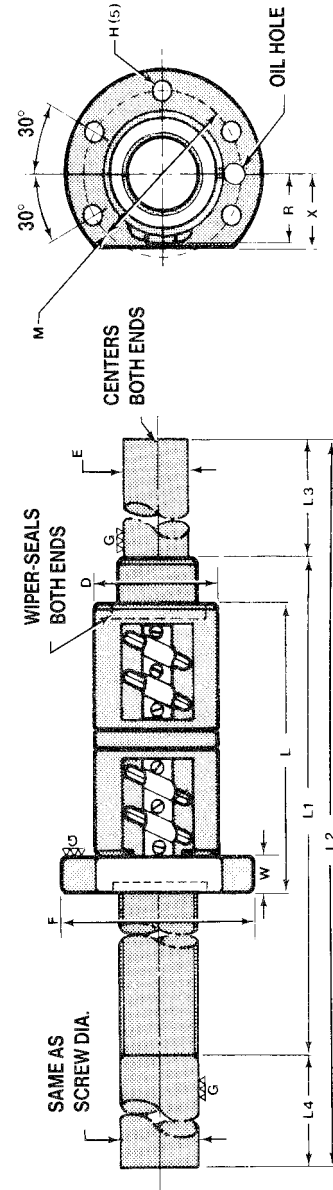

Precision Ground Ball Screw Availability

Availability Table — Metric Leads

| SCREW SHAFT DIAMETER (MM) | LEAD (MM) | | | | | | | | | | | | | | | |
|------------------------------|-----------|-----|---|-----|---|---|---|---|----|----|----|----|----|----|----|----|
| | 1 | 1.5 | 2 | 2.5 | 4 | 5 | 6 | 8 | 10 | 12 | 16 | 20 | 25 | 32 | 40 | 50 |
| 4 | ● | | | | | | | | | | | | | | | |
| 6 | ● | | | | | | | | | | | | | | | |
| 8 | ● | ● | ● | | | | | | | | | | | | | |
| 10 | | | ● | ● | ● | | | | | | | | | | | |
| 12 | | | ● | ● | | ● | | | ● | | | | | | | |
| 14 | | | | | | ● | | ● | | | | | | | | |
| 15 | | | | | | | | | ● | | | ● | | | | |
| 16 | | | ● | ● | | ● | | | | | ● | | | ● | | |
| 20 | | | | | ● | ● | | | ● | | | ● | | | ● | |
| 25 | | | | | ● | ● | ● | | ● | | | ● | ● | | | ● |
| 28 | | | | | | ● | ● | | | | | | | | | |
| 32 | | | | | | ● | ● | ● | ● | | | | ● | ● | | |
| 36 | | | | | | | | | ● | | | | | | | |
| 40 | | | | | | ● | | ● | ● | ● | | | | | | |
| 45 | | | | | | | | | ● | | | | | | | |
| 50 | | | | | | | | | ● | | | | | | | |

Availability Table — Inch Leads

| SHAFT O.D. | .472" (12MM) | .630" (16MM) | .784" (20MM) | .787" (20MM) | .984" (25MM) | 1.260" (32MM) | 1.496" (38MM) | 1.732" (44MM) | 1.969" (50MM) |
|---------------|-----------------|-----------------|-----------------|-----------------|-----------------|------------------|------------------|------------------|------------------|
| .200 | ● | ● | | ● | ● | ● | ● | ● | ● |
| .250 | | | | | ● | ● | ● | ● | ● |
| .500 | | ● | ● | ● | ● | ● | ● | ● | ● |
| 1.00 | | | | | ● | ● | ● | | |

Complete Screw Assemblies

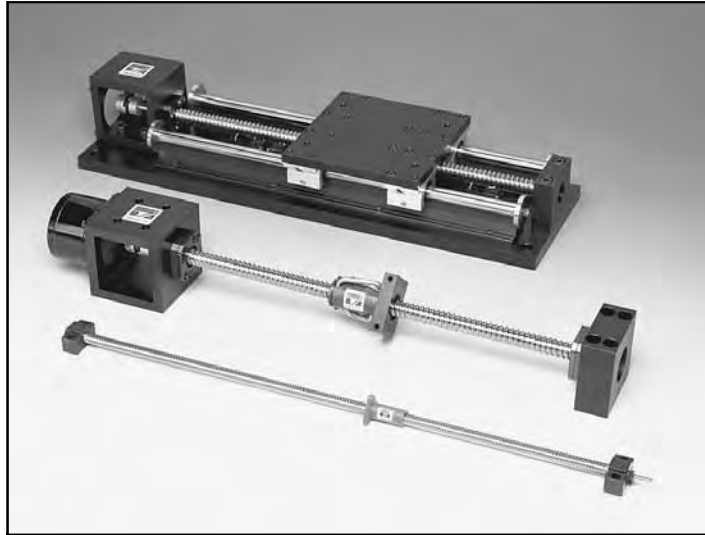

| | |
|---|----|
| How to Pick Your Assembly | 52 |
| Screw Assemblies w/ NEMA 17 Motor Mounts. | 53 |
| Screw Assemblies w/ NEMA 23 Motor Mounts. | 54 |
| Screw Assemblies w/ NEMA 34 Motor Mounts. | 55 |
| Screw Assemblies w/ NEMA 42 Motor Mounts. | 56 |
| Screw Assemblies w/ Bearing Mounts | 57 |
| Radial Bearing Support Housings | 59 |

How to Pick Your Assembly



Our Drive Assembly units allow for a drop-in solution with Ball Screws and Actuators' quality components. Available in most screw sizes, both ACME and Ball threads, our Drive Assemblies free designers to concentrate on larger design issues. Our standard Drive Assemblies can be assembled and shipped quickly, providing the right solution when you need it.

- STEP 1.** Select your screw-nut combination depending on load, cost, speed, stroke, backlash, accuracy and environmental constraints. Use critical speed and column loading charts as general guides (pages 86 to 87). Note allowable bearing sizes for your screw-nut selection before returning to this section.
- STEP 2.** Determine end configuration due to load, length and rotational velocity. Refer to critical speed and column loading charts as required (pages 86 to 87). We offer fixed-fixed, fixed-simple and fixed free bearing arrangements.
- STEP 3.** Noting allowable bearing size, turn to correct NEMA motor size page for assembly dimensions.
- STEP 4.** Add Nut Part Number with Stroke to Drive Assembly Part Number

(EXAMPLE)

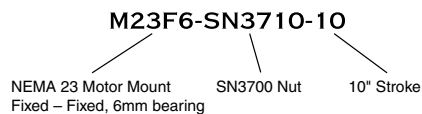

- STEP 5.** Give us a call at 1-800-882-8857.

Screw Assemblies w/ NEMA 17 Motor Mounts

For 1/4" to 3/8" Ball & Lead Screws
and 6mm to 10mm Ball and Lead Screws

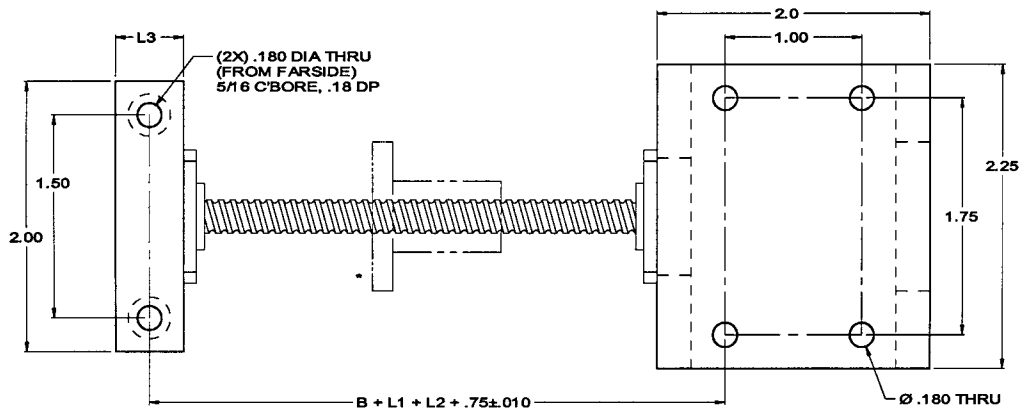
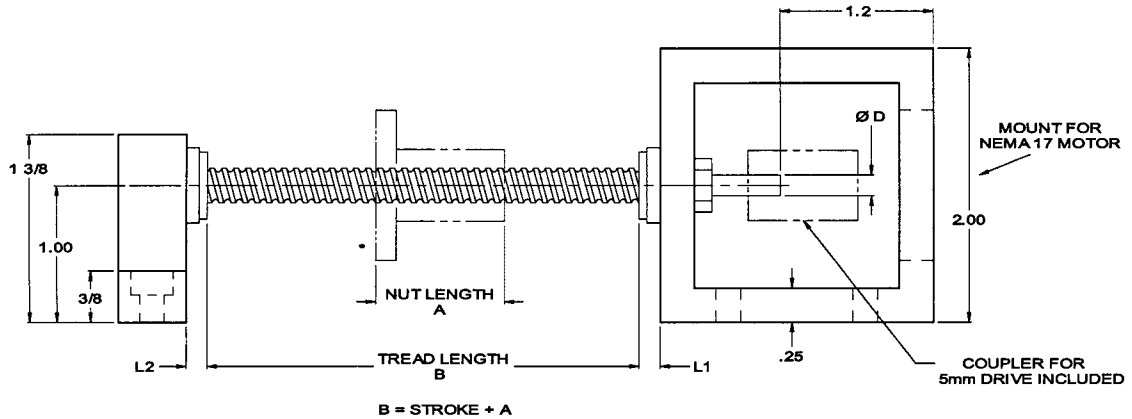

| PART NUMBER (SEE EXAMPLE) | AXIAL* LOAD | BEARING SUPPORT | D | L1 | L2 | L3 |
|------------------------------|----------------|--------------------|-----|------|------|-----|
| M17F4 | 50 lbs | 4mm | 3mm | .155 | .155 | .50 |
| M17S4 | | | 3mm | .155 | — | .50 |
| M17E4 | | | 3mm | .155 | — | — |

*Maximum assembly thrust load, Do Not Exceed. Do not exceed dynamic load rating of the lead nut.

EXAMPLE: M17F4

M-17-F-4

| | | | |
|----------------|-----------------|-----------------|--------------|
| Motor Mount | NEMA Motor Size | Bearing Config. | Bearing Size |
| 17 | F = Fixed | 4mm | |
| 23 | S = Simple | 6mm | |
| 34 | E = Free | 8mm | |
| 42 | | 12mm | |
| | | 20mm | |

Screw Assemblies w/ NEMA 23 Motor Mounts

For 3/8" to 5/8" Ball & Lead Screws
and 6mm to 14mm Ball and Lead Screws

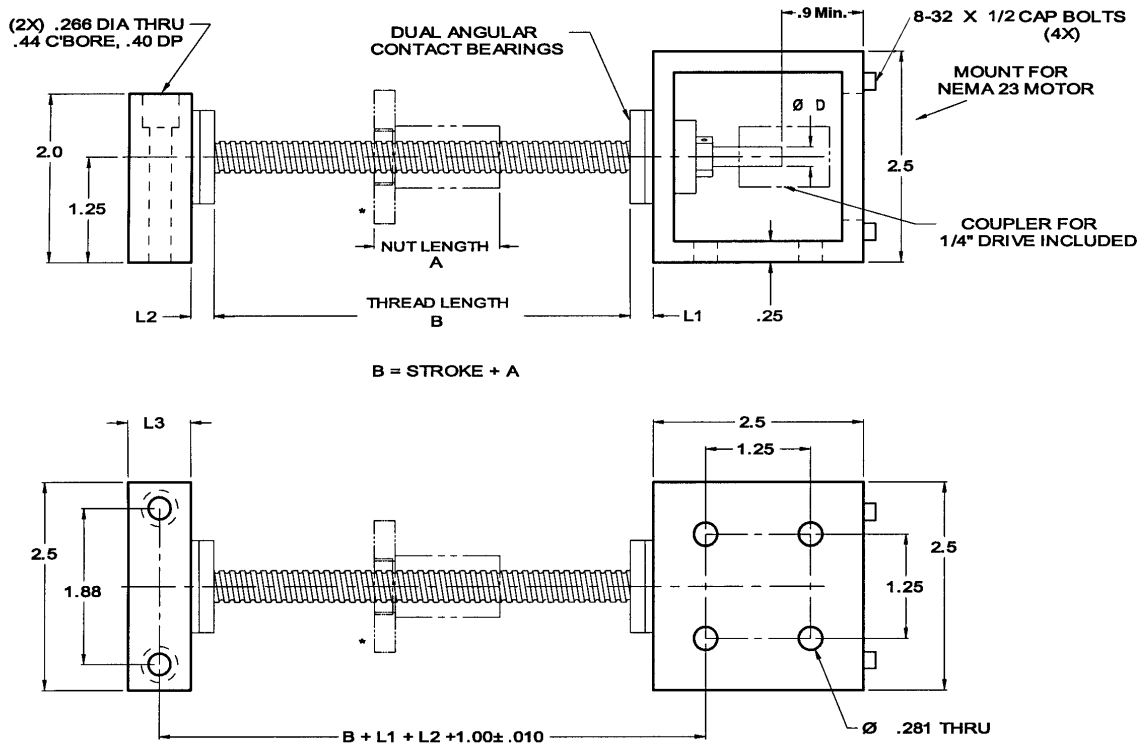

| PART NUMBER (SEE EXAMPLE) | AXIAL LOAD* | BEARING SUPPORT | D | L1 | L2 | L3 |
|------------------------------|----------------|--------------------|------|------|------|-----|
| M23F4 | 50 lbs | 4mm | 3mm | .155 | .155 | .75 |
| M23S4 | | | 3mm | .155 | — | .75 |
| M23E4 | | | 3mm | .155 | — | — |
| M23F6 | 230 lbs | 6mm | .187 | .275 | .275 | .75 |
| M23S6 | | | .187 | .275 | — | .75 |
| M23E6 | | | .187 | .275 | — | — |
| M23F8 | 326 lbs | 8mm | .250 | .354 | .354 | .75 |
| M23S8 | | | .250 | .354 | — | .75 |
| M23E8 | | | .250 | .354 | — | — |

*Maximum assembly thrust load, Do Not Exceed. Do not exceed dynamic load rating of the lead nut.

EXAMPLE: M23F6

M-23-F-6

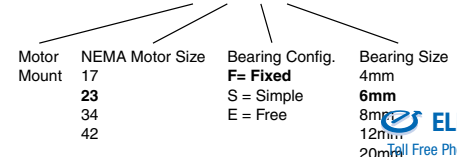

Screw Assemblies w/ NEMA 34 Motor Mounts

For 3/4" to 1" Ball & Lead Screws
and 16mm to 24mm Ball and Lead Screws

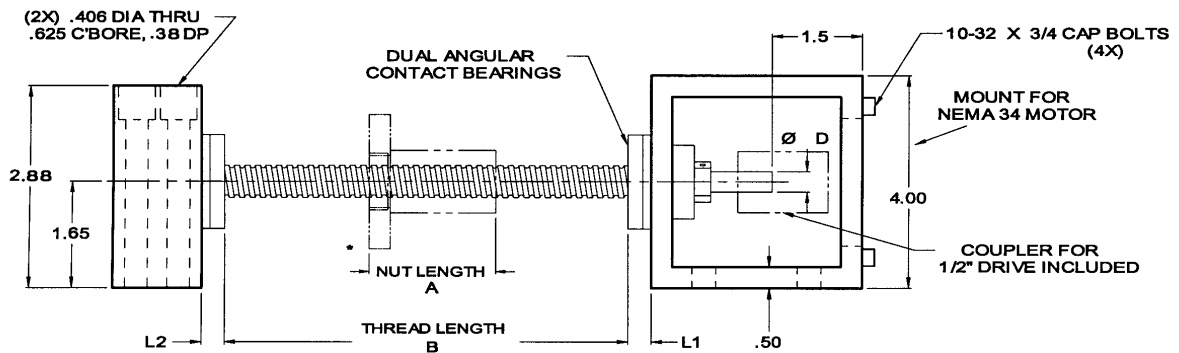

$$B = \text{STROKE} + A$$

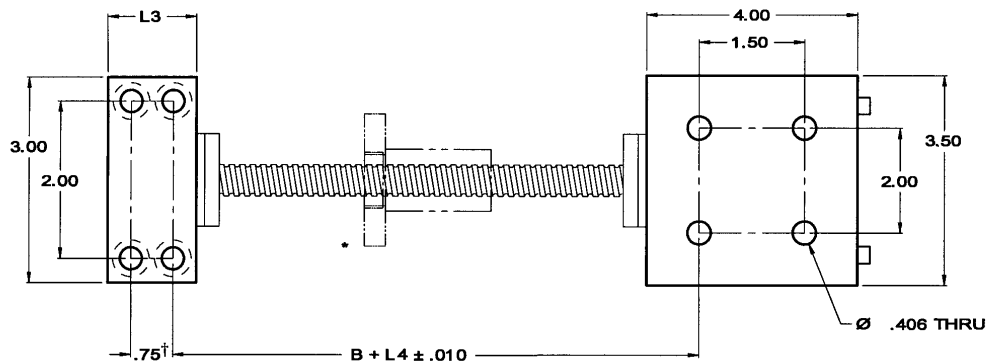

| PART NUMBER (SEE EXAMPLE) | AXIAL LOAD* | BEARING SUPPORT | D | L1 | L2 | L3 | L4 |
|------------------------------|----------------|--------------------|------|------|------|------|------|
| M34F12 | 680 lbs | 12mm | .375 | .395 | .395 | 1.50 | 2.42 |
| M34S12 | | | .375 | .395 | — | 1.00 | 2.15 |
| M34E12 | | | .375 | .395 | — | — | — |

*Maximum assembly thrust load, Do Not Exceed. Do not exceed dynamic load rating of the lead nut.

†M34F12 only. M34S12 has two mounting holes centered on L3.

EXAMPLE: M34F12 M-34-F-12

| | | | |
|-------------|-----------------|-----------------|--------------|
| Motor Mount | NEMA Motor Size | Bearing Config. | Bearing Size |
| 17 | 23 | F= Fixed | 4mm |
| 34 | 42 | S = Simple | 6mm |
| | | E = Free | 8mm |
| | | | 12mm |
| | | | 20mm |

Screw Assemblies w/ NEMA 42 Motor Mounts

For 1" to 1-1/2" Ball & Lead Screws
and 25mm to 38mm Ball and Lead Screws

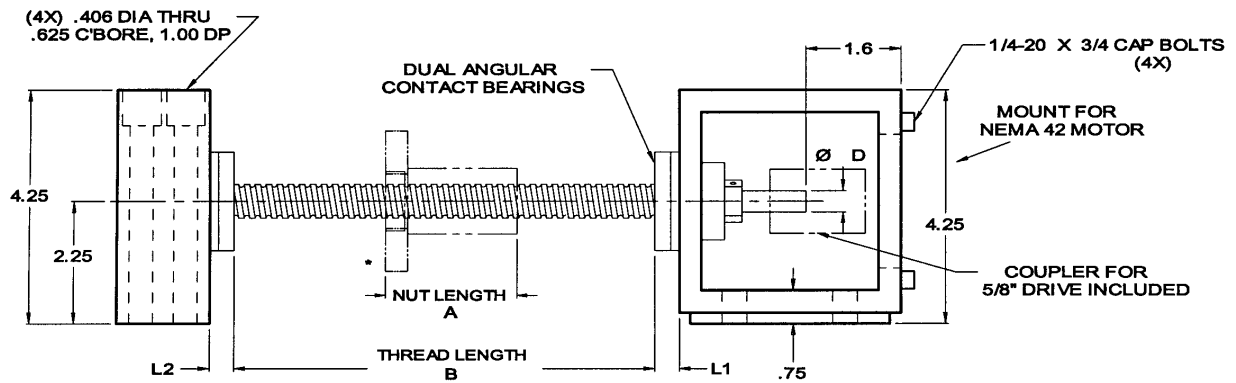

$B = \text{STROKE} + A$

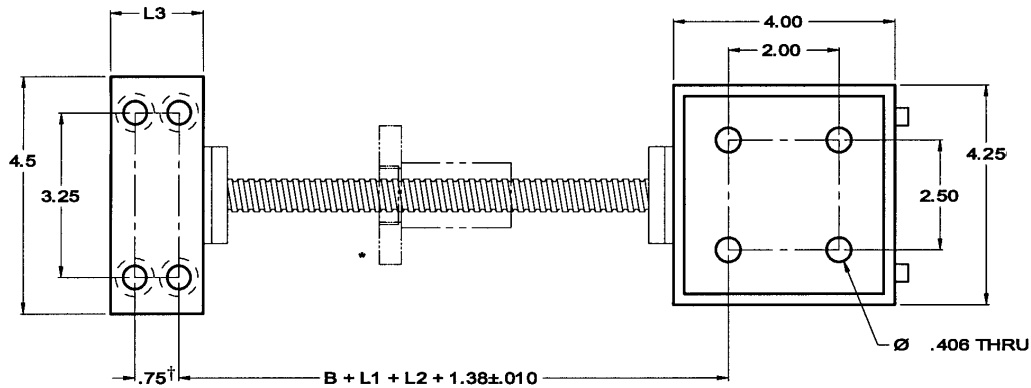

| PART NUMBER (SEE EXAMPLE) | AXIAL LOAD* | BEARING SUPPORTS | D | L1 | L2 | L3 |
|------------------------------|----------------|---------------------|------|------|------|------|
| M42F20 | 1,850 lbs | 20mm | .500 | .869 | .869 | 1.50 |
| M42S20 | | | .500 | .869 | — | .75 |
| M42E20 | | | .500 | .869 | — | — |

*Maximum assembly thrust load, Do Not Exceed. Do Not Exceed. Do not exceed dynamic load rating of the lead nut.
†M42F20 only. M42S20 has two mounting holes centered on L3.

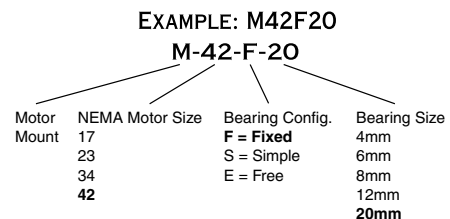

Screw Assemblies w/ Bearing Mounts

Flange Mount

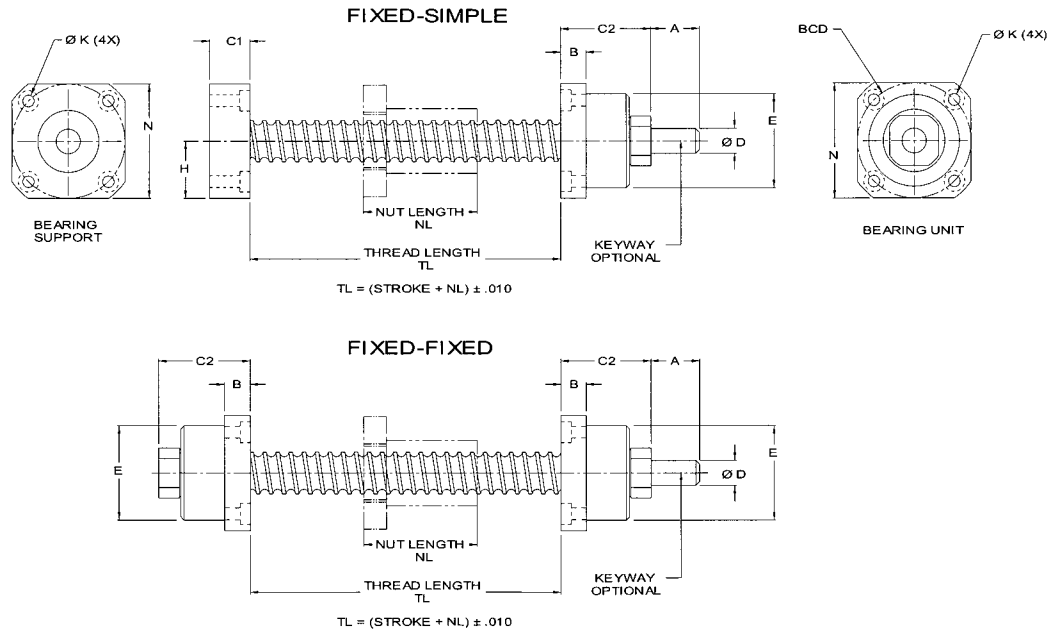

| ASSEMBLY No. | AXIAL LOAD* | A | B | C1 | C2 | D ± .000 .001 | E | BCD | K | H | N |
|--------------|-------------|------|-----|------|------|------------------|-------|------|-------------------------------------|------|------|
| B6EF | 230 lbs | .63 | .28 | — | 1.04 | .187 | .866 | 1.10 | 0.114 thru .22 cbore .14 deep | .55 | 1.10 |
| B6ES | | | | .37 | | | | | | | |
| B6EE | | | | — | | | | | | | |
| B8EF | 326 lbs | .63 | .35 | — | 1.22 | .250 | 1.102 | 1.38 | 0.134 thru .26 cbore .16 deep | .69 | 1.38 |
| B8ES | | | | .50 | | | | | | | |
| B8EE | | | | — | | | | | | | |
| B12EF | 680 lbs | .75 | .40 | — | 1.40 | .375 | 1.417 | 1.73 | 0.177 thru .32 cbore .16 deep | .67 | 1.73 |
| B12ES | | | | .62 | | | | | | | |
| B12EE | | | | — | | | | | | | |
| B15EF | 760 lbs | .75 | .59 | — | 1.82 | .500 | 1.575 | 1.97 | 0.216 thru .37 cbore .24 deep | 1.02 | 2.05 |
| B15ES | | | | .62 | | | | | | | |
| B15EE | | | | — | | | | | | | |
| B20EF | 1,852 lbs | 1.00 | .87 | — | 2.61 | .625 | 2.244 | 2.76 | 0.260 thru .43 cbore .39 deep | 1.34 | 2.67 |
| B20ES | | | | 1.00 | | | | | | | |
| B20EE | | | | — | | | | | | | |

*Maximum assembly thrust load, Do Not Exceed. Do not exceed the dynamic load rating of the lead nut

EXAMPLE: B12FF

B-12-E-F

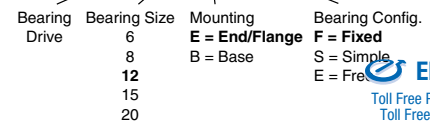

Screw Assemblies w/ Bearing Mounts

Base Mount†

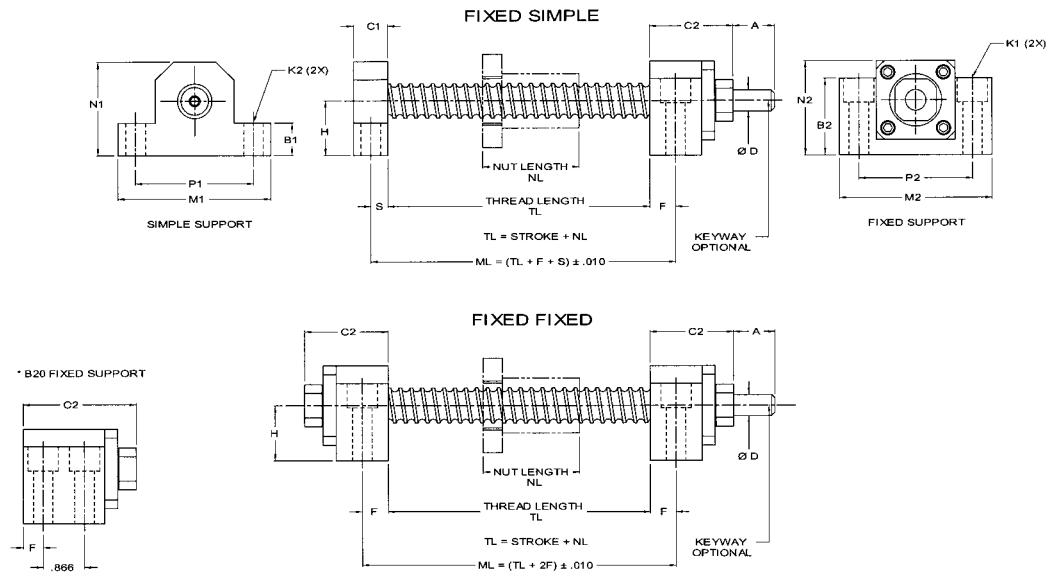

| ASSEMBLY No. | AXIAL LOAD* | F | S | A | C1 | C2 | D ± .000 .001 | H | K1 | K2 | M1 | M2 | N1 | N2 | P1 | P2 | B1 | B2 | | |
|--------------|-------------|-----|-----|------|------|------|---------------|-------|-------------------------------------|------|------|------|------|----|------|------|------|----|-----|------|
| B6BF | 230 lbs | .40 | — | .63 | — | 1.00 | .187 | .512 | 0.216 thru .37 cbore .43 deep | — | — | 1.66 | 1.66 | — | .98 | 1.26 | 1.18 | — | .39 | .78 |
| B6BS | | | .19 | | .37 | | | | | .95 | .98 | | | | | | | | | |
| B6BE | | | — | | — | | | | | — | — | | | | | | | | | |
| B8BF | 326 lbs | .45 | — | .63 | — | 1.18 | .250 | .669 | 0.260 thru .43 cbore .47 deep | — | — | 2.01 | 2.05 | — | 1.26 | 1.50 | 1.50 | — | .51 | 1.02 |
| B8BS | | | .25 | | .50 | | | | | 1.18 | 1.26 | | | | | | | | | |
| B8BE | | | — | | — | | | | | — | — | | | | | | | | | |
| B12BF | 680 lbs | .47 | — | .75 | — | 1.40 | .375 | .984 | 0.354 thru .55 cbore .43 deep | — | — | 2.76 | 2.76 | — | 1.70 | 2.13 | 2.05 | — | .60 | 1.38 |
| B12BS | | | .31 | | .62 | | | | | 1.69 | 1.70 | | | | | | | | | |
| B12BE | | | — | | — | | | | | — | — | | | | | | | | | |
| B15BF | 760 lbs | .49 | — | .75 | — | 1.67 | .500 | 1.181 | 0.433 thru .67 cbore .59 deep | — | — | 3.15 | 3.15 | — | 1.97 | 2.44 | 2.36 | — | .71 | 1.58 |
| B15BS | | | .31 | | .62 | | | | | 2.00 | 1.97 | | | | | | | | | |
| B15BE | | | — | | — | | | | | — | — | | | | | | | | | |
| B20BF | 1,852 lbs | .39 | — | 1.00 | — | 2.44 | .625 | 1.181 | 0.433 thru .67 cbore .59 deep | — | — | 3.74 | 3.74 | — | 2.28 | 3.07 | 2.95 | — | .79 | 1.77 |
| B20BS | | | .50 | | 1.00 | | | | | 2.44 | 2.28 | | | | | | | | | |
| B20BE | | | — | | — | | | | | — | — | | | | | | | | | |

†Note flange radius. Some flanges may interfere with the mounting surface.

*Maximum assembly load. Do not exceed the dynamic load rating of the lead nut.

Radial Bearing Support Housings

Base Mount Housing

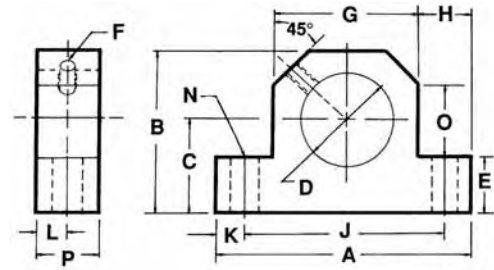

| PART NO. | A | B | C +0.0 -.05 | D +.05 -0.0 | E | F SET SCREW | G | H | J | K | L | N HOLE DIA. | O | P |
|----------|-----|----|-------------------|-------------------|----|-------------------|----|------|----|-----|------|-------------------|------|------|
| B6-HP | 42 | 24 | 13 | 12.75* | 10 | #10-24 | 20 | 11 | 32 | 5 | 4.75 | 5.5 | 9 | 9.5 |
| B8-HP | 51 | 30 | 17 | 17.05 | 13 | #10-24 | 25 | 13 | 38 | 6.5 | 6.35 | 6.6 | 12 | 12.7 |
| B10-HP | 70 | 43 | 25 | 22.05 | 15 | 1/4"-20 | 36 | 17 | 54 | 8 | 7.9 | 9 | 18 | 15.8 |
| B12-HP | 70 | 43 | 25 | 26.05 | 15 | 1/4"-20 | 36 | 17 | 54 | 8 | 7.9 | 9 | 18 | 15.8 |
| B15-HP | 80 | 51 | 30 | 32.05 | 18 | 1/4"-20 | 45 | 17.5 | 62 | 9 | 7.9 | 9 | 22.5 | 15.8 |
| B20-HP | 95 | 62 | 30 | 47.05 | 20 | 1/4"-20 | 60 | 17.5 | 78 | 8.5 | 12.7 | 11 | 25 | 25.4 |
| B25-HP | 101 | 69 | 35 | 52.05 | 25 | 1/4"-20 | 66 | 17.5 | 84 | 8.5 | 12.7 | 11 | 30 | 25.4 |

*Dimension D for B6-HP is a counterbore, 6.3mm deep with 8mm thru hole.
Dimensions are millimeters. To convert to inches, divide by 25.4.

Warning: Excessive torque on set screw may damage radial bearing.

Radial Bearing Support Housings

Flange Mount Housing

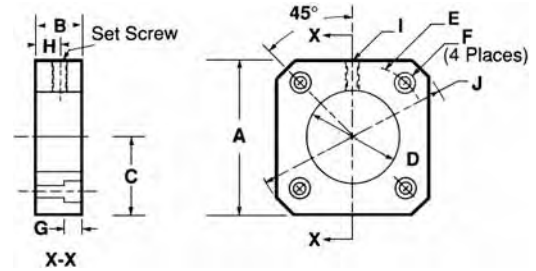

| PART NO. | A | B | C | D +.05 -0 | E BOLT CIRCLE | F | | G C. BORE DEEP | H | I SET SCREW | J |
|----------|----|------|------|-----------------|---------------------|------|---------|----------------------|------|-------------------|----|
| | | | | | | BORE | C. BORE | | | | |
| B6-HF | 28 | 9.5 | 14 | 12.75* | 28 | 2.9 | 5.5 | 3.5 | 4.75 | #10-24 | 35 |
| B8-HF | 35 | 12.7 | 17.5 | 17.05 | 35 | 3.4 | 6.5 | 4 | 6.35 | #10-24 | 43 |
| B10-HF | 42 | 15.8 | 21 | 22.05 | 42 | 4.5 | 8 | 4 | 7.9 | 1/4"-20 | 52 |
| B12-HF | 44 | 15.8 | 22 | 26.05 | 44 | 4.5 | 8 | 4 | 7.9 | 1/4"-20 | 54 |
| B15-HF | 52 | 15.8 | 26 | 32.05 | 50 | 5.5 | 9 | 6 | 7.9 | 1/4"-20 | 63 |
| B20-HF | 68 | 25.4 | 34 | 47.05 | 70 | 6.6 | 11 | 10 | 12.7 | 1/4"-20 | 85 |
| B25-HF | 79 | 25.4 | 39.5 | 52.05 | 80 | 9 | 15 | 13 | 12.7 | 1/4"-20 | 98 |

*Dimension D for B6-HP is a counterbore, 6.3mm deep with 8mm thru hole.
Dimensions are millimeters. To convert to inches, divide by 25.4.

Radial Bearings

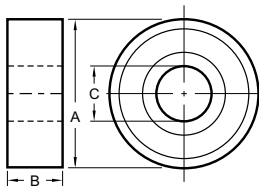

| PART NO. | FITS HOUSING NO. | A DIAMETER | B WIDTH | C BORE |
|----------|------------------|---------------|------------|-----------|
| B6-R3 | B6-HP or B6-HF | 12.7 | 5 | 4.76 |
| B8-R6 | B8-HP or B8-HF | 17 | 6 | 6 |
| B10-R8 | B10-HP or B10-HF | 22 | 7 | 8 |
| B12-R10 | B12-HP or B12-HF | 26 | 8 | 10 |
| B15-R15 | B15-HP or B15-HF | 32 | 9 | 15 |
| B20-R20 | B20-HP or B20-HF | 47 | 14 | 20 |
| B25-R25 | B25-HP or B25-HF | 52 | 15 | 25 |

Note: Radial bearings are supplied standard with thrust bearing units. Radial bearing housings must be ordered separately. Housing material is low carbon steel with a black oxide coating.

Stock Stages

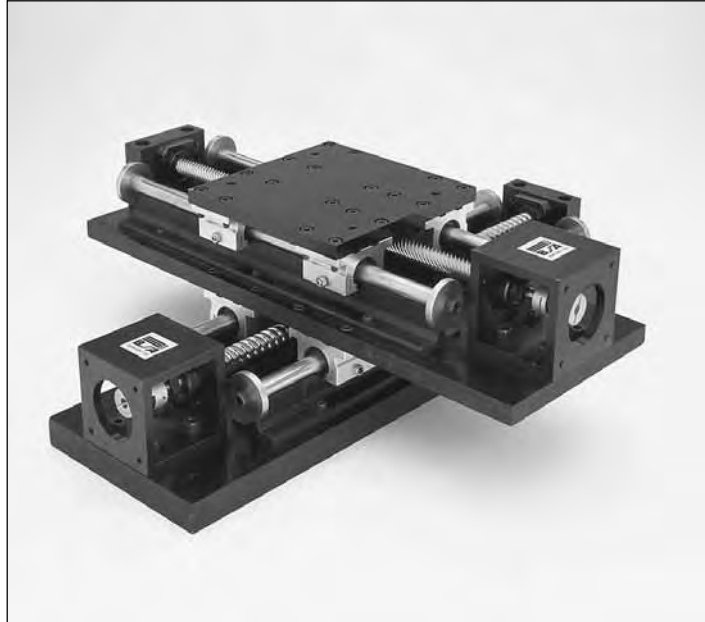

| | |
|--------------------------------------|----|
| Stock Stages Custom Stages | 62 |
| T23 Stock Stage Assembly | 63 |
| T34 Stock Stage Assembly | 64 |
| T42 Stock Stage Assembly | 65 |

Stock Stages Custom Stages

Overview

- Large Selection of Screw Types and Leads
- Stainless Steel Lead Screws and Antibacklash Supernuts™
- Precision Rolled Ball Screws with Single and Optional Preloaded Ball Nuts
- Completely Wired and Installed Overtravel and Home Switches
- Precision Linear Rails and Preloaded Linear Pillow Blocks
- Anodized Aluminum and Hardened Steel Components

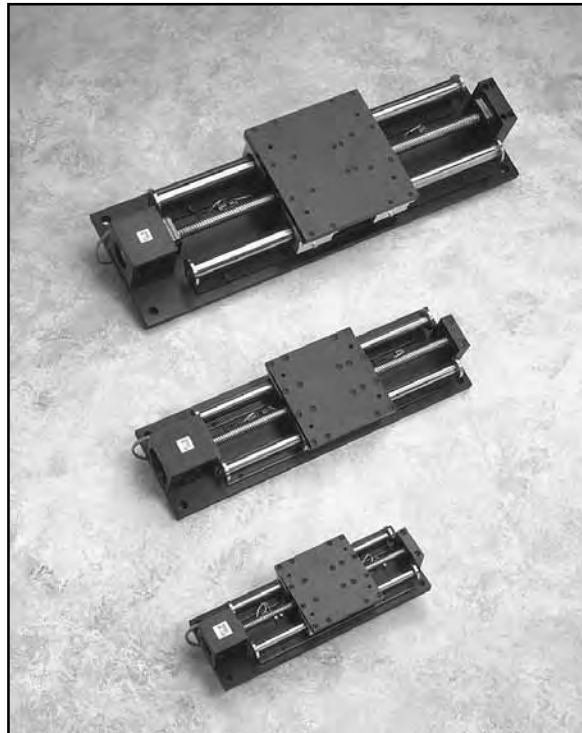

T23 Stock Stage Assembly

1/2" Precision Ball and Acme Screws NEMA 23 Motor Mount

| TABLE DATA | SCREW DATA |
|---|--|
| Rail Diameter: 1/2 in. | Screw Diameter: 1/2 in. |
| Maximum Table Load: 220 lbs* | Lead Screw Axial Load Rating: 125 lbs |
| Moment Rating (Roll, Yaw, Pitch): 120 in-lbs* | Ball Screw Axial Load Rating: 240 lbs* |
| Carriage Weight: 2.5 lbs | Maximum Rotation Speed: 2000 RPM |

Note: For vertical applications, mount motor side up. DXF and DWG files available upon request.

Note: Stage includes end of travel switches, one home switch and 1/4" motor shaft coupler.

* Based on 50 million inches of travel.

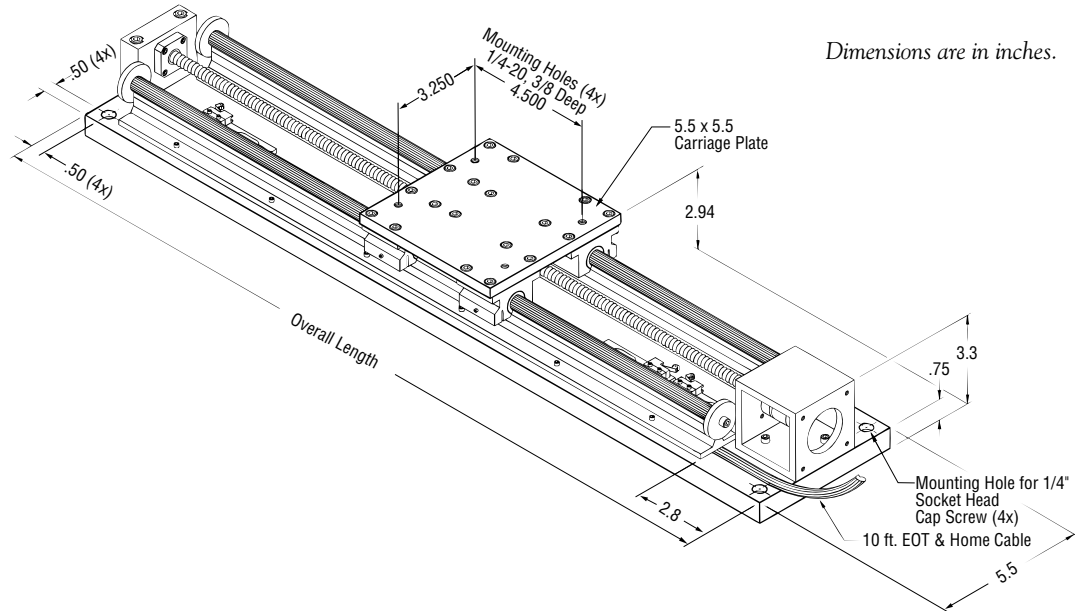

| TO ORDER | LEAD | 6" STROKE ¹ | 12" STROKE | 18" STROKE | 24" STROKE |
|-------------------------------------|------|------------------------|------------|------------|------------|
| Precision Acme Screw | 0.10 | T2306-A.1 | T2312-A.1 | T2318-A.1 | T2324-A.1 |
| | 0.20 | T2306-A.2 | T2312-A.2 | T2318-A.2 | T2324-A.2 |
| | 0.50 | T2306-A.5 | T2312-A.5 | T2318-A.5 | T2324-A.5 |
| | 1.00 | T2306-A1.0 | T2312-A1.0 | T2318-A1.0 | T2324-A1.0 |
| Precision Ball Screw ² | 0.20 | T2306-B.2 | T2312-B.2 | T2318-B.2 | T2324-B.2 |
| | 0.50 | T2306-B.5 | T2312-B.5 | T2318-B.5 | T2324-B.5 |
| Overall Length | | 16.4" | 22.4" | 28.4" | 34.4" |
| Screw Inertia (oz in ²) | | .354 | .519 | .676 | .841 |

1. All strokes have an extra 1/2" of travel at both ends.

2. Single ball nut repeatability 0.002".

T34 Stock Stage Assembly

3/4" Precision Ball and Acme Screws NEMA 34 Motor Mount

| TABLE DATA | SCREW DATA |
|---|--|
| Rail Diameter: 3/4 in. | Screw Diameter: 3/4 in. |
| Maximum Table Load: 530 lbs* | Lead Screw Axial Load Rating: 250 lbs |
| Moment Rating (Roll, Yaw, Pitch): 600 in-lbs* | Ball Screw Axial Load Rating: 620 lbs* |
| Carriage Weight: 6.0 lbs | Maximum Rotation Speed: 2000 RPM |

Note: For vertical applications, mount motor side up. DXF and DWG files available upon request.

Note: Stage includes end of travel switches, one home switch and 1/2" motor shaft coupler.

*Based on 50 million inches of travel.

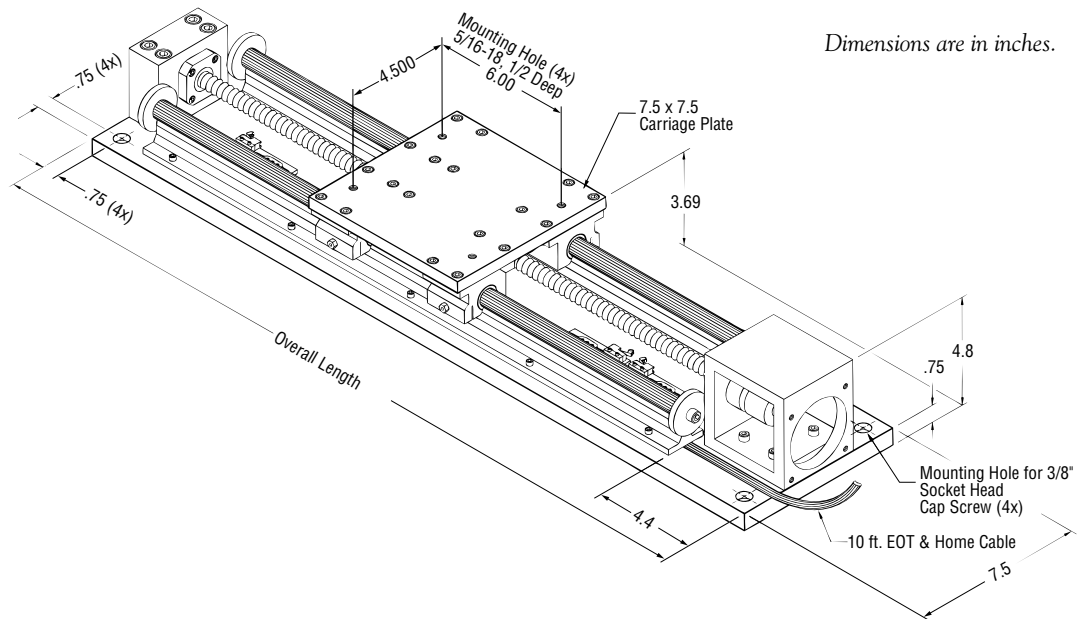

| TO ORDER | LEAD | 6" STROKE ¹ | 12" STROKE | 18" STROKE | 24" STROKE |
|-------------------------------------|------|------------------------|------------|------------|------------|
| Precision Acme Screw | 0.20 | T3406-A.2 | T3412-A.2 | T3418-A.2 | T3424-A.2 |
| | 0.50 | T3406-A.5 | T3412-A.5 | T3418-A.5 | T3424-A.5 |
| Precision Ball Screw ² | 0.20 | T3406-B.2 | T3412-B.2 | T3418-B.2 | T3424-B.2 |
| | 0.50 | T3406-B.5 | T3412-B.5 | T3418-B.5 | T3424-B.5 |
| Overall Length | | 20.4" | 26.4" | 32.9" | 38.9" |
| Screw Inertia (oz in ²) | | 2.09 | 2.92 | 3.70 | 4.54 |

1. All strokes have an extra 1/2" of travel at both ends.

2. Single ball nut repeatability 0.002".

T42 Stock Stage Assembly

1" Precision Ball and Acme Screws NEMA 42 Motor Mount

| TABLE DATA | SCREW DATA |
|--|---|
| Rail Diameter: 1.25 in. | Screw Diameter: 1.0 in. |
| Maximum Table Load: 1450 lbs* | Lead Screw Axial Load Rating: 300 lbs |
| Moment Rating (Roll, Yaw, Pitch): 2400 in-lbs* | Ball Screw Axial Load Rating: 1560 lbs* |
| Carriage Weight: 19.0 lbs | Maximum Rotation Speed: 2000 RPM |

Note: For vertical applications, mount motor side up. DXF and DWG files available upon request.

Note: Stage includes end of travel switches, one home switch and 5/8" motor shaft coupler.

*Based on 50 million inches of travel.

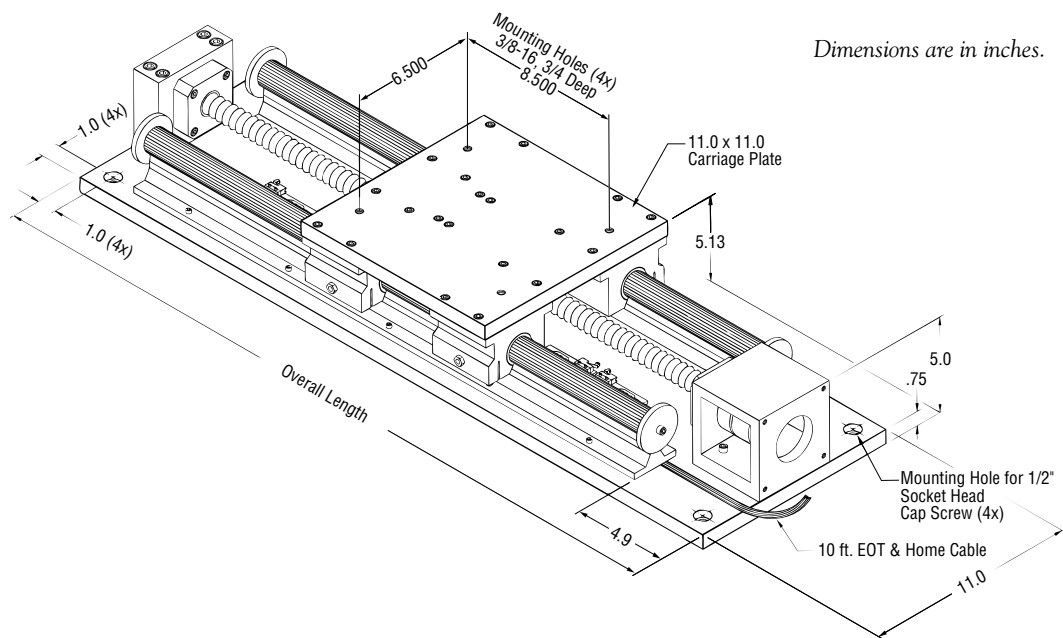

| TO ORDER | LEAD | 18" STROKE | 24" STROKE | 36" STROKE |
|--------------------------------------|------|------------|------------|------------|
| Precision Acme Screw | 0.20 | T4218-A.2 | T4224-A.2 | T4236-A.2 |
| | 0.50 | T4218-A.5 | T4224-A.5 | T4236-A.5 |
| | 1.00 | T4218-A1.0 | T4224-A1.0 | T4236-A1.0 |
| Precision Ball Screw ² | 0.25 | T4218-B.25 | T4224-B.25 | T4236-B.25 |
| | 0.50 | T4218-B.5 | T4224-B.5 | T4236-B.5 |
| Overall Length | | 37.3" | 43.3" | 55.3" |
| Screw Inertia (oz in ²) | | 13.2 | 15.9 | 21.2 |

1. All strokes have an extra 1/2" of travel at both ends.

2. Single ball nut repeatability 0.002".

Rails & Bearings



| | |
|------------------------------------|----|
| Round Rail – Full Support | 68 |
| Round Rail – End Support | 70 |
| 500 Series Ball Profile Rail | 72 |

Round Rail — Full Support

Linear Bearing Assembly with 2 LSOH Series Bearing Units

- Will accept 1° misalignment
- Quiet running high load capacity
- Adjustable preload
- Assemblies come standard with seals at each end of bearing unit.
- Butted supports may have a gap of up to .2" between sections.

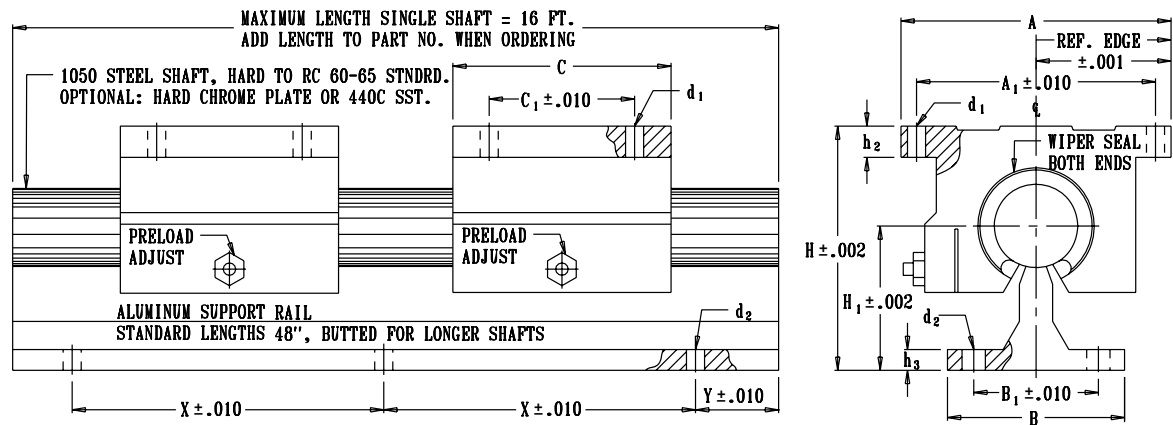

| REF. SHAFT DIA. | ASSEMBLY PART NO. ADD LENGTH IN INCHES | DIMENSIONS IN INCHES | | | | | | | | | | | | | | DYNAMIC LOAD RATING LBS. ¹ |
|-----------------|--|----------------------|----------------|-------|--------|----------------|----------------|----------------|----------------|-----------------------|----------------|----------------|----------------|------|------|---------------------------------------|
| | | HEIGHT | CENTER | WIDTH | LENGTH | BEARING MOUNTS | | | | SUPPORT RAIL MOUNTING | | | | | | |
| | | H | H ₁ | A | C | A ₁ | C ₁ | d ₁ | h ₂ | B | B ₁ | d ₂ | h ₃ | X | Y | |
| 1/2" | ADO50- | 1.812 | 1.125 | 2.000 | 1.500 | 1.688 | 1.000 | .156 | .250 | 1.50 | 1.000 | .169 | .188 | 4.00 | 2.00 | 230 |
| 5/8" | ADO62- | 2.000 | 1.125 | 2.500 | 1.750 | 2.125 | 1.130 | .188 | .281 | 1.63 | 1.125 | .193 | .250 | 4.00 | 2.00 | 320 |
| 3/4" | ADO75- | 2.437 | 1.500 | 2.750 | 1.875 | 2.375 | 1.250 | .188 | .315 | 1.75 | 1.250 | .221 | .250 | 6.00 | 3.00 | 470 |
| 1" | ADO100- | 2.937 | 1.750 | 3.250 | 2.625 | 2.875 | 1.750 | .218 | .375 | 2.13 | 1.500 | .281 | .250 | 6.00 | 3.00 | 780 |
| 1-1/4" | ADO125- | 3.625 | 2.125 | 4.000 | 3.375 | 3.500 | 2.000 | .218 | .437 | 2.50 | 1.875 | .343 | .313 | 6.00 | 3.00 | 1170 |
| 1-1/2" | ADO150- | 4.250 | 2.500 | 4.750 | 3.750 | 4.125 | 2.500 | .281 | .500 | 3.00 | 2.250 | .343 | .375 | 8.00 | 4.00 | 1560 |

1. The dynamic load rating is based on a travel life expectancy of 2 million inches using a ground shaft with a minimum of RC 58 hardness. Load rating listed per bearing. Loads away from shaft support are derated 50%. Loads on single bearing unit are half of rate shown.

Round Rail — Full Support

Tandem Linear Bearing Assembly with LTO Series Tandem Bearing Units

- Will accept 1° misalignment
- Quiet running high load capacity
- Adjustable preload
- Assemblies come standard with seals at each end of bearing unit.
- Butted supports may have a gap of up to .2" between sections.

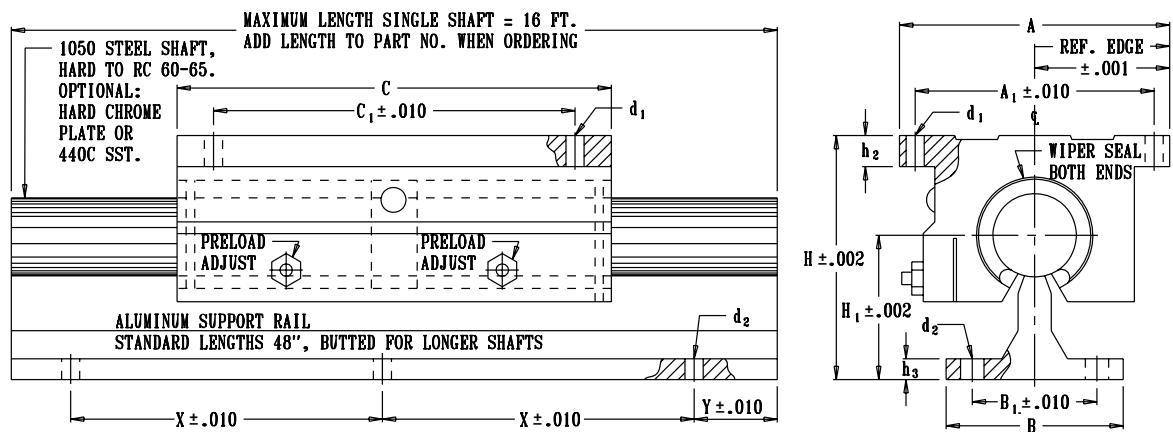

| REF. SHAFT DIA. | ASSEMBLY PART NO. ADD LENGTH IN INCHES | DIMENSIONS IN INCHES | | | | | | | | | | | | | | DYNAMIC LOAD RATING LBS. ¹ |
|-----------------|--|----------------------|----------------|-------|--------|----------------|----------------|----------------|----------------|-----------------------|----------------|----------------|----------------|------|------|---------------------------------------|
| | | HEIGHT | CENTER | WIDTH | LENGTH | BEARING MOUNTS | | | | SUPPORT RAIL MOUNTING | | | | | | |
| | | H | H ₁ | A | C | A ₁ | C ₁ | d ₁ | h ₂ | B | B ₁ | d ₂ | h ₃ | X | Y | |
| 1/2" | ATO50- | 1.812 | 1.125 | 2.000 | 3.50 | 1.688 | 2.50 | .156 | .250 | 1.50 | 1.000 | .169 | .188 | 4.00 | 2.00 | 460 |
| 5/8" | ATO62- | 2.000 | 1.125 | 2.500 | 4.00 | 2.125 | 3.00 | .188 | .281 | 1.63 | 1.125 | .193 | .250 | 4.00 | 2.00 | 640 |
| 3/4" | ATO75- | 2.437 | 1.500 | 2.750 | 4.50 | 2.375 | 3.50 | .188 | .315 | 1.75 | 1.250 | .221 | .250 | 6.00 | 3.00 | 940 |
| 1" | ATO100- | 2.937 | 1.750 | 3.250 | 6.00 | 2.875 | 4.50 | .218 | .375 | 2.13 | 1.500 | .281 | .250 | 6.00 | 3.00 | 1560 |
| 1-1/4" | ATO125- | 3.625 | 2.125 | 4.000 | 7.50 | 3.500 | 5.50 | .218 | .437 | 2.50 | 1.875 | .343 | .313 | 6.00 | 3.00 | 2340 |
| 1-1/2" | ATO150- | 4.250 | 2.500 | 4.750 | 9.00 | 4.125 | 6.50 | .281 | .500 | 3.00 | 2.250 | .343 | .375 | 8.00 | 4.00 | 3120 |

1. The dynamic load rating is based on a travel life expectancy of 2 million inches using a ground shaft with a minimum of RC 58 hardness. Loads away from shaft support are derated 50%. Loads on single bearing unit are half of rate shown.

Round Rail — End Support

Linear Bearing Assembly with 2 LSCH Series Bearing Units

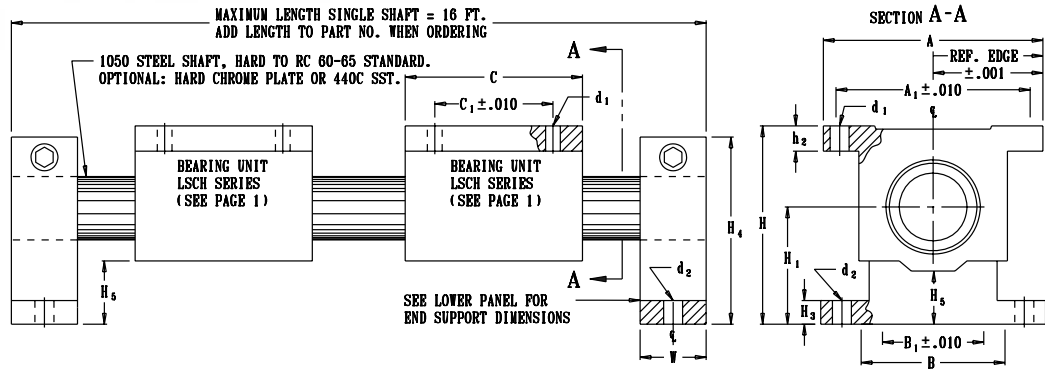
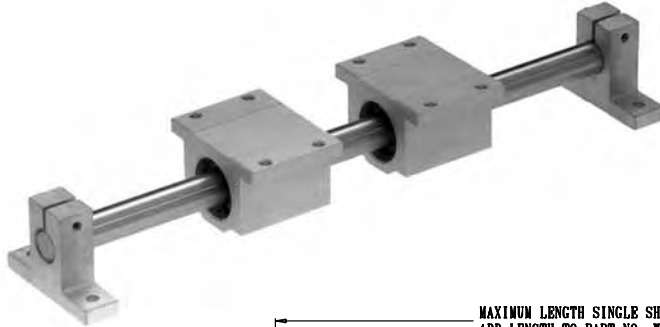

| REF. SHAFT DIA. | ASSEMBLY PART NO. ADD LENGTH IN INCHES | DIMENSIONS IN INCHES | | | | | | | | | REF. SHAFT SUPPORTS PART No. | DYNAMIC LOAD RATING LBS. ¹ |
|-----------------|--|----------------------|----------------|-------|--------|----------------|----------------------|----------------------|----------------|----------------|------------------------------|---------------------------------------|
| | | HEIGHT | CENTER | WIDTH | LENGTH | CLEARANCE | BEARING UNIT MOUNT | | | | | |
| | | H ±.001 | H ₁ | A | C | H ₅ | A ₁ ±.001 | C ₁ ±.001 | d ₁ | h ₂ | | |
| 1/4" | AED025- | 1.125 | .6875 | 1.625 | 1.188 | .312 | 1.312 | 0.750 | .156 | .188 | ES025 | 60 |
| 3/8" | AED037- | 1.250 | 0.750 | 1.750 | 1.313 | .312 | 1.437 | 0.875 | .156 | .188 | ES037 | 100 |
| 1/2" | AED050- | 1.687 | 1.000 | 2.000 | 1.688 | .437 | 1.688 | 1.000 | .156 | .250 | ES050 | 255 |
| 5/8" | AED062- | 1.875 | 1.000 | 2.500 | 1.938 | .250 | 2.125 | 1.125 | .188 | .281 | ES062 | 450 |
| 3/4" | AED075- | 2.187 | 1.250 | 2.750 | 2.063 | .437 | 2.375 | 1.250 | .188 | .313 | ES075 | 600 |
| 1" | AED100- | 2.687 | 1.500 | 3.250 | 2.813 | .500 | 2.875 | 1.750 | .219 | .375 | ES100 | 1050 |
| 1-1/4" | AED125- | 3.250 | 1.750 | 4.000 | 3.625 | .437 | 3.500 | 2.000 | .219 | .438 | ES125 | 1500 |
| 1-1/2" | AED150- | 3.750 | 2.000 | 4.750 | 4.000 | .500 | 4.125 | 2.500 | .281 | .500 | ES150 | 2000 |
| 2" | AED200- | 4.625 | 2.500 | 6.000 | 5.000 | .562 | 5.250 | 3.250 | .406 | .625 | ES200 | 3000 |

1. The dynamic load rating is based on a travel life expectancy of 2 million inches using a ground shaft with a minimum of RC 58 hardness. Load rating listed per bearing. Loads on single bearing unit are half of rate shown.

Round Rail — End Support

Linear Bearing Assembly with LTC Series Tandem Bearing Unit

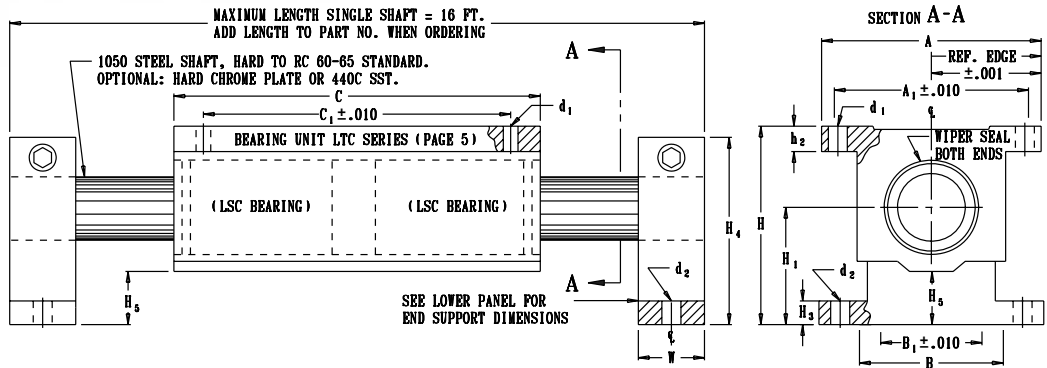
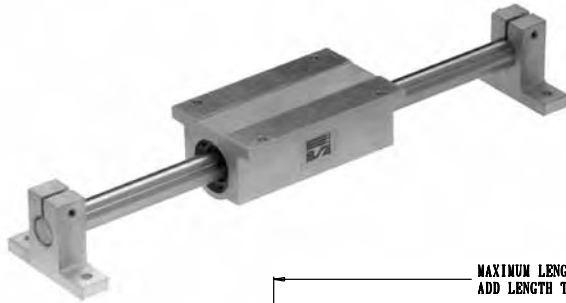

| REF. SHAFT DIA. | ASSEMBLY PART NO. ADD LENGTH IN INCHES | DIMENSIONS IN INCHES | | | | | | | | | | REF. SHAFT SUPPORTS PART NO. | DYNAMIC LOAD RATING LBS. ¹ |
|-----------------|--|----------------------|----------------|-------|--------|----------------|--------------------|----------------|----------------|----------------|-------|------------------------------|---------------------------------------|
| | | HEIGHT | CENTER | WIDTH | LENGTH | CLEARANCE | BEARING UNIT MOUNT | | | | | | |
| | | H | H ₁ | A | C | H ₅ | A ₁ | C ₁ | d ₁ | h ₂ | | | |
| 1/4" | AET025- | 1.125 | .6875 | 1.625 | 2.50 | .312 | 1.312 | 2.000 | .156 | .188 | ES025 | 120 | |
| 3/8" | AET037- | 1.250 | 0.750 | 1.750 | 2.75 | .312 | 1.437 | 2.250 | .156 | .188 | ES037 | 200 | |
| 1/2" | AET050- | 1.687 | 1.000 | 2.000 | 3.50 | .437 | 1.688 | 2.500 | .156 | .250 | ES050 | 510 | |
| 5/8" | AET062- | 1.875 | 1.000 | 2.500 | 4.00 | .250 | 2.125 | 3.000 | .188 | .281 | ES062 | 900 | |
| 3/4" | AET075- | 2.187 | 1.250 | 2.750 | 4.50 | .437 | 2.375 | 3.500 | .188 | .313 | ES075 | 1200 | |
| 1" | AET100- | 2.687 | 1.500 | 3.250 | 6.00 | .500 | 2.875 | 4.500 | .219 | .375 | ES100 | 2100 | |
| 1-1/4" | AET125- | 3.250 | 1.750 | 4.000 | 7.50 | .437 | 3.500 | 5.500 | .219 | .438 | ES125 | 3000 | |
| 1-1/2" | AET150- | 3.750 | 2.000 | 4.750 | 9.00 | .500 | 4.125 | 6.500 | .281 | .500 | ES150 | 4000 | |

1. The dynamic load rating is based on a travel life expectancy of 2 million inches using a ground shaft with a minimum of RC 58 hardness.

500 Series Ball Profile Rail



Features and Benefits

Superior Design. Superior Quality.

- Straight rails through advanced grinding technologies
- Simple installation and greater accuracy with joint-free rails up to 6 meters
- Smooth, quiet movement through patented insert molded recirculation paths and optimized geometries
- Extended lubrication life as a result of grease pockets built into the recirculation path
- Multiple carriage styles and sizes available
- On site field modifiable modular seals
- Rail and carriage options from stock or short delivery
- Customization with expanded accessory offering

| Style | Size | Accuracy | Basic Part Number | | | | Appropriate Rail Standard Rail | Max. Single Piece Rail Length (mm) |
|------------------------|------|----------|-------------------|----------|----------|----------|-----------------------------------|---------------------------------------|
| | | | Clearance | Preload | | 0.13C | | |
| | | | | 0.03C | 0.08C | | | |
| Standard Carriage A | 15 | H | 511H15A0 | 511H15A1 | 511H15A2 | — | 521H15A | 1500 |
| | | P | — | 511P15A1 | 511P15A2 | 511P15A3 | 521P15A | |
| | | U | — | 511U15A1 | 511U15A2 | 511U15A3 | 521U15A | |
| | 20 | H | 511H20A0 | 511H20A1 | 511H20A2 | — | 521H20A | 3000 |
| | | P | — | 511P20A1 | 511P20A2 | 511P20A3 | 521P20A | |
| | | U | — | 511U20A1 | 511U20A2 | 511U20A3 | 521U20A | |
| | 25 | H | 511H25A0 | 511H25A1 | 511H25A2 | — | 521H25A | 6000 |
| | | P | — | 511P25A1 | 511P25A2 | 511P25A3 | 521P25A | |
| | | U | — | 511U25A1 | 511U25A2 | 511U25A3 | 521U25A | |
| | 30 | H | 511H30A0 | 511H30A1 | 511H30A2 | — | 521H30A | 6000 |
| | | P | — | 511P30A1 | 511P30A2 | 511P30A3 | 521P30A | |
| | | U | — | 511U30A1 | 511U30A2 | 511U30A3 | 521U30A | |
| | 35 | H | 511H35A0 | 511H35A1 | 511H35A2 | — | 521H35A | 6000 |
| | | P | — | 511P35A1 | 511P35A2 | 511P35A3 | 521P35A | |
| | | U | — | 511U35A1 | 511U35A2 | 511U35A3 | 521U35A | |
| | 45 | H | 511H45A0 | 511H45A1 | 511H45A2 | — | 521H45A | 6000 |
| | | P | — | 511P45A1 | 511P45A2 | 511P45A3 | 521P45A | |
| | | U | — | 511U45A1 | 511U45A2 | 511U45A3 | 521U45A | |

EXTENDED STANDARD CARRIAGES

The 500 Series Roller Profile carriages are available with the Thomson standard dowel holes or lubrication inlets.

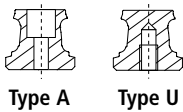

RAIL TYPES AND ACCESSORIES

The 500 Series Ball Profile Rail is available in two configurations:

- Bolt down from the top – 521 Type A
 - Bolt up from the bottom – 521 Type U
- The standard 521 rail mounting holes can be plugged or sealed after installation with the options below.

PLASTIC PLUGS

531HP plastic plugs are an inexpensive and simple method to seal the rail attachment bolt area. The plastic plugs are easily driven in place to any 500 Series Ball Rail with a soft non-metallic drift. They can easily be removed.

MYLAR TAPE

A simple and low cost alternative is specialty Mylar tape that can be placed quickly on the top surface of the rail. Part number 531RT is available in 3 meter lengths.

STAINLESS STEEL COVER STRIP

Option 531RCS utilizes a special rail (521 Type C) and stainless steel cover strip that is easily installed with the proper mounting tool.

Many additional product configurations are available. For more help selecting the correct Profile Rail for your application refer to our online Product Advisor at http://www.danahermotion.com/design_tools/

Linear Actuators



| | |
|----------------------------------|----|
| Actuators..... | 74 |
| Standard Electro-Mechanical..... | 75 |
| Custom Actuators..... | 76 |

Actuators



Simple Selection

- 24 Basic Models
- 25 lbs. to 1000 lbs. Capacities
- Standard Strokes from 2” to 24”
- Operating Voltages of 12VDC, 24VDC, 115 VAC & 230 VAC
- Maintenance Free—Lifetime Lubrication
- Easy to Install—Standard Clevis and Trunnion Mounts
- Bi-directional—Both Compression (PUSH) and Tension (PULL) Capability
- Weather Resistant (DC models only)—For indoor and outdoor use. DC models are sealed and gasketed throughout.
- Energy Efficient—High efficiency components assure minimum power draw.
- Low Cost, Trouble-Free—No expensive plumbing or hydraulic components, no fluid or oil leakage.

Standard Electro-Mechanical

| CAPACITY | VOLTAGE | LIMIT SWITCHES | STYLE | FEATURES | STROKES |
|-------------------------|----------------------|---------------------------|---|--|--------------------------|
| 25 lbs. & 75 lbs. | 12 VDC & 24 VDC | Available (Fixed) |  | Sealed for indoor and outdoor use potentiometer feedback available | 2", 4", 6" |
| 250 lbs. | 12 VDC | No |  | Sealed for indoor and outdoor use 2 speed ranges overload slip clutch | 4", 8", 12" |
| 500 lbs. & 1000 lbs. | 12 VDC & 24 VDC | No |  | Sealed for indoor and outdoor use highly efficient ball screw drive fail safe brake | 4", 8", 12" |
| 500 lbs. & 1000 lbs. | 115 VAC & 230 VAC | No |  | Ball screw drive Thermal overload protection | 4", 8", 12", 18", 24" |
| 500 lbs. & 1000 lbs. | 24 VDC | Available (Adjustable) |  | Sealed for indoor and outdoor use with potentiometer feedback and adjustable mounting bracket | 4", 8", 12", 18", 24" |
| 500 lbs. & 1000 lbs. | 115 VAC & 230 VAC | Available (Adjustable) |  | Potentiometer feedback ball screw drive | 4", 8", 12", 18", 24" |

SELECTION PROCEDURE

1. Determine your load, speed required, and power source available.
2. Determine the stroke (travel in one direction). Make sure the actuator you select has a stroke long enough for your application.
3. Determine the duty cycle. All models have a 25% duty cycle rating at full load. Duty cycle rating can be significantly increased with reduced loads.
4. Consider other requirements such as side loads. Side loads will radically reduce life and load ratings. Shock loads have the same effect. If possible avoid these types of loads or add some type of bearing guide and/or shock absorber at the travel limits.

To see our complete line of industrial and precision actuators, please refer to our website: <http://www.danahermotion.com/products>.

Custom Actuators

Custom Selection

If your design criteria does not match our large selection of stock assemblies, let Ball Screws and Actuators' Design Engineering Staff discuss your requirements. From simple custom adapters for our stock products to complete high precision tables, our engineering, manufacturing and quality departments offer a comprehensive solution to your custom linear motion needs.

- Design engineering staff
- World class machine shop
- Quality control for verifiable quality assurance

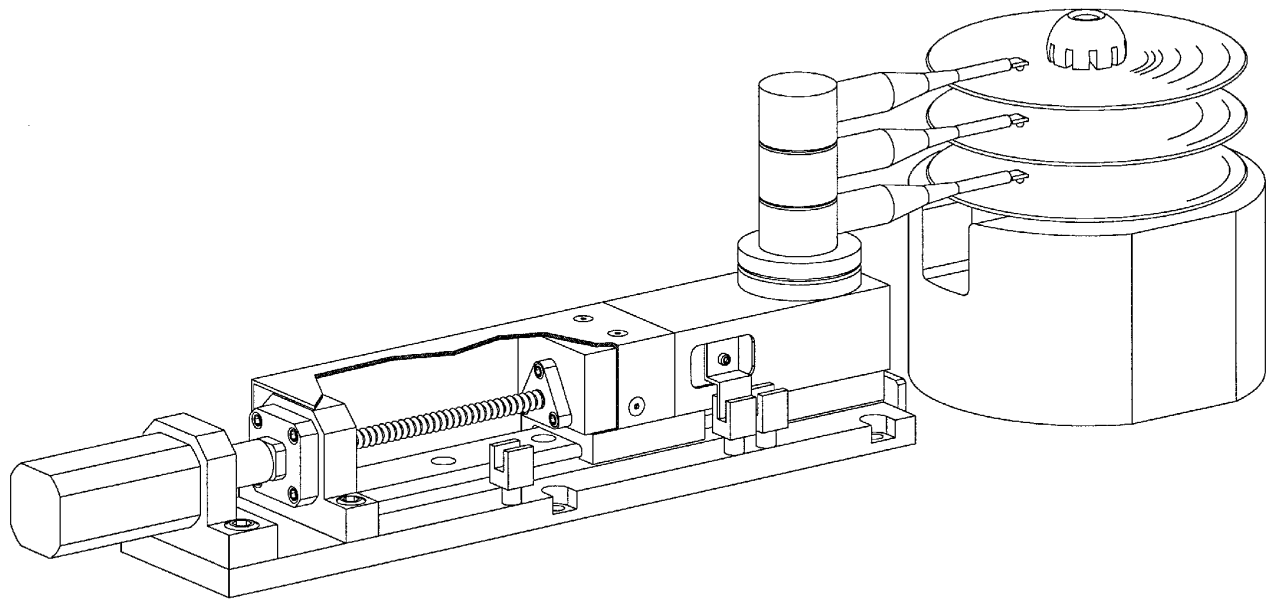
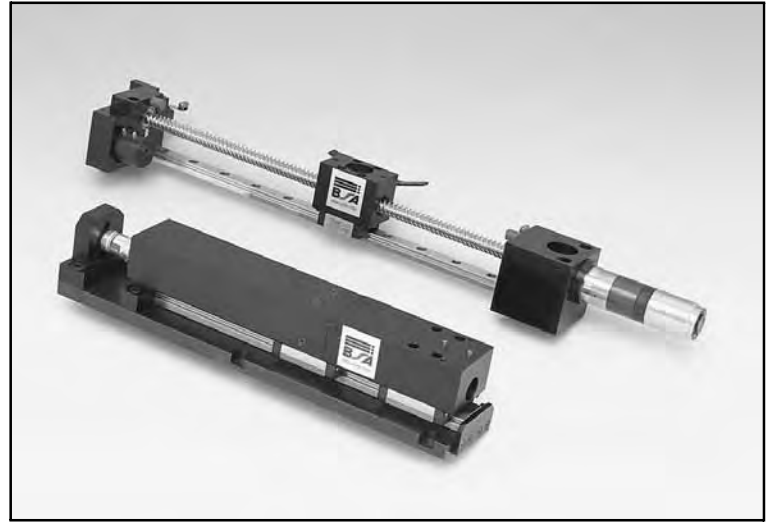

Accessories



| | |
|---------------------------------|----|
| Couplings Flex Type | 78 |
| Three Piece Type Couplers | 79 |
| Grease | 80 |
| Wiper Kits | 81 |
| Standard Mounting Flanges | 83 |

Couplings Flex Type

Flexible-Zero Backlash Stainless Steel & Aluminum

- Ideal for Lead Screw Applications
- Misalignment Capability
- Withstands Hostile Environments and Temperatures
- Zero Backlash
- Torsionally Rigid
- One Piece Construction
- Allows for Near Butting of Shafts
- Constant Velocity
- No Lubrication Required
- Aircraft Grade Stainless & Aluminum

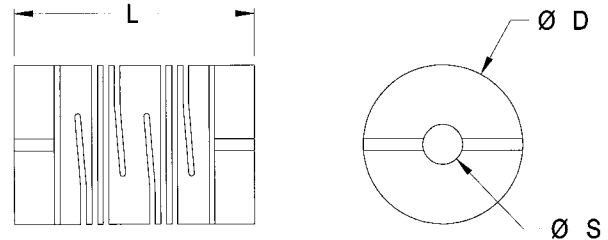

| PART NUMBERS | S BORE ±.002 | L LENGTH ± 1/64" | D DIAMETER ± 1/64" | MAXIMUM TORQUE INCH LBS. |
|--------------|--------------------|------------------------|--------------------------|-----------------------------|
| AC18 | .188 | 1-1/4 | 3/4 | 3.5 |
| SC18 | | .90 | | 4.9 |
| AC25 | .250 | 1-1/2 | 1.0 | 7.8 |
| SC25 | | 1-1/4 | | 13 |
| AC31 | .313 | 1-1/2 | 1.0 | 7.3 |
| SC31 | | 1-1/4 | | 12 |
| AC37 | .375 | 1-3/4 | 1-1/4 | 14 |
| SC37 | | 2-3/8 | | 27 |
| AC50 | .500 | 2-1/4 | 1-1/2 | 29 |
| SC50 | | 2-5/8 | | 50 |
| AC62 | .625 | 2-1/2 | 2.0 | 54 |
| SC62* | | 3.0 | | 96 |
| AC75 | .750 | 2-1/2 | 2.0 | 48 |
| SC75* | | 3.0 | | 84 |

- AC Part No's. are made of 7075-T6 Aluminum, Anodized AC Parts will accept 3° angular and .010" parallel offset misalignment.
- SC Part No's. are made of 17-4 CRES Stainless Steel. SC parts will accept 5° angular and .010" parallel offset misalignment.

Three Piece Type Couplers

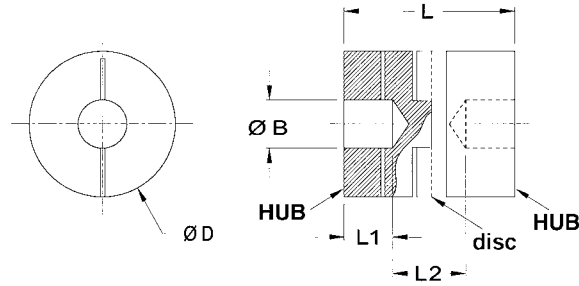

| PART NUMBER | BORE | O.D. | L | L1 | L2 | USE WITH DISK |
|-------------|-------------|------|------|------|------|---------------|
| HUB1875 | 0.188 | 0.75 | 1.02 | 0.37 | 0.28 | DISK75 |
| HUB2575 | 0.250 | 0.75 | 1.02 | 0.37 | 0.28 | |
| HUB0575 | 0.197 (5mm) | 0.75 | 1.02 | .037 | .028 | |
| HUB25100 | 0.250 | 1.00 | 1.28 | 0.46 | 0.36 | DISK100 |
| HUB37100 | 0.375 | 1.00 | 1.28 | 0.46 | 0.36 | |
| HUB37131 | 0.375 | 1.31 | 1.89 | 0.59 | 0.71 | DISK131 |
| HUB50131 | 0.500 | 1.31 | 1.89 | 0.59 | 0.71 | |
| HUB37163 | 0.375 | 1.63 | 2.00 | 0.70 | 0.60 | DISK163 |
| HUB50163 | 0.500 | 1.63 | 2.00 | 0.70 | 0.60 | |
| HUB62163 | 0.625 | 1.63 | 2.00 | 0.70 | 0.60 | |

Ordering Instructions: Specify any two “Hubs” with the same O.D. and one matching DISK.
 For example: HUB25100, HUB37100, DISK100

Bore Adaptors

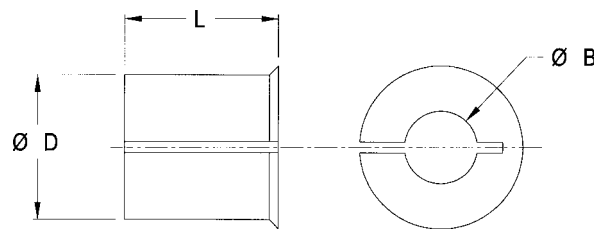

| PART NUMBER | BORE | O.D. | L |
|-------------|-------------|-------------|------|
| ADP0305 | 0.118 (3mm) | 0.197 (5mm) | 0.17 |
| ADP1825 | 0.1875 | 0.250 | 0.26 |

Grease

Overview

We offer a full compliment of lubricants including our low vapor pressure greases for clean room and vacuum applications. The TriGel line is specifically formulated to offer a lubrication solution for a wide range of linear motion applications. Choose the appropriate gel for your requirements and get the utmost performance out of your BSA products.



LUBRICATION SELECTION CHART FOR BALL & LEAD SCREW ASSEMBLIES

| BSA GEL TYPE | TRIGEL-300S | TRIGEL-450R | TRIGEL-600SM | TRIGEL-1200SC | TRIGEL-1800RC |
|---|--|---------------------------------|-----------------------------------|--|---|
| Application | Acme Screws, Supernuts, Plastic Nuts | Ball Screws, Linear Bearings | Bronze Nuts | Acme Plastic Nuts, Clean Room, High Vacuum | Ball Screws, Linear Bearings, Bronze Nuts, Clean Room, Vacuum |
| Maximum Temperature | 200°C (392°F) | 125°C (257°F) | 125°C (257°F) | 250°C (482°F) | 125°C (257°F) |
| Mechanism Materials | Plastic on Plastic or Metal | Metal on Metal | Metal on Metal Bronze on Steel | Plastics or Metals, any Combination | Metal on Metal |
| Mechanical Load | Light | Moderate | Moderate to Heavy | Light to Moderate | Moderate |
| Precision Positioning | Not recommended w/o OEM testing | Not recommended w/o OEM testing | Not recommended w/o OEM testing | Usually OK | Usually OK |
| Very Low Torque Variation Over Temperature | Yes | — | — | Yes | — |
| Very Low Starting Torque | Yes | Yes | — | Yes | Yes |
| Compatibility w/ Reactive Chemicals | Not recommended w/o OEM testing | Not recommended w/o OEM testing | Not recommended w/o OEM testing | Usually OK | Not recommended w/o OEM testing |
| Compatibility w/ Plastics and Elastomers | May cause silicone rubber seals to swell | May cause EPDM seals to swell | May cause EPDM seals to swell | Usually OK | May cause EPDM seals to swell |
| Clean Room Use | Not recommended | Not recommended | Not recommended | Usually OK | Usually OK |
| High Vacuum Use | Not recommended | Not recommended | Not recommended | Usually OK | Usually OK |
| Vapor Pressure (25°C) | Varies with lot | Varies with lot | Varies with lot | 8 x 10 ⁻⁹ torr | 4 x 10 ⁻⁹ torr |
| Lubricant Price 10cc Syringe** 1 Pound Tube | ✓ ✓ | ✓ ✓ | 4 oz tube | ✓ NA | ✓ NA |

*Maximum temperature for continuous exposure. Higher surge temperatures may be permissible but should be validated in the actual end use by the OEM. Low temperature limits are -15°C or lower. Consult BSA for specifics.

Wiper Kits

Overview

Brush type wiper kits maximize ball bearing screw performance by helping to spread lubricant over the length of the screw and preventing internal ball nut contamination from foreign materials. Wiper kits are optional on models R-0308 through R-1504, and standard on models R-1502 through R-3066. Optional and standard wiper kits are also available for comparable zero backlash/preload ball nut assemblies.

For heavily contaminated environments, BSA recommends the use of metal shields, bellows type enclosures or extensions in conjunction with brush wipers for maximum protection.

Type A

For these ball bearing screw sizes, end caps attached to the ball nut and flange hold the wipers in position. The Type A wiper kit includes a flange end cap. If the application does not use a flange, discard the flange end cap and epoxy the wiper to the end of the ball nut.

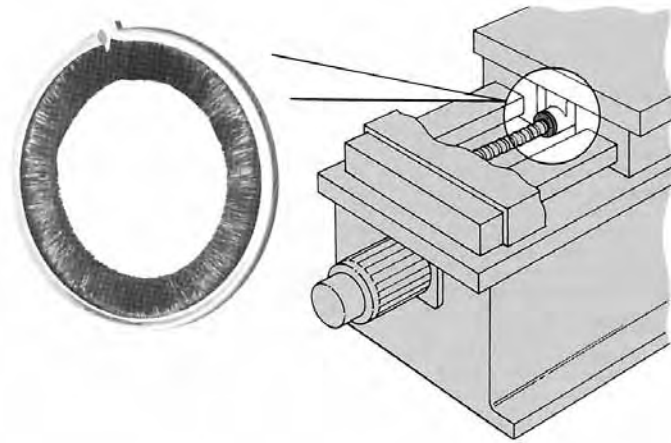
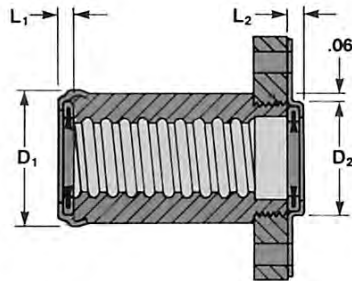

| MODEL† | D ₁ MAX. | D ₂ MAX. | L ₁ MAX. | L ₂ MAX. | WIPER PART NUMBER |
|--------|------------------------|------------------------|------------------------|------------------------|----------------------|
| R-0308 | .838 | .880 | .139 | .148 | 8103-101-002 |
| RC0308 | .838 | .880 | .139 | .148 | 8103-101-002 |
| R-0505 | 1.122 | 1.138 | .139 | .148 | 8105-101-002 |
| R-0502 | 1.122 | 1.138 | .139 | .148 | 8105-101-002 |
| RS0502 | 1.122 | 1.138 | .139 | .148 | 8105-101-002 |
| RC0605 | 1.177 | 1.060 | .139 | .148 | 8106-101-002 |
| RK0605 | 1.177 | 1.060 | .139 | .148 | 8106-101-002 |
| R-0705 | 1.382 | 1.230 | .158 | .148 | 8107-101-002 |
| R-0702 | 1.382 | 1.230 | .158 | .148 | 8107-101-002 |
| RC0705 | 1.382 | 1.230 | .158 | .148 | 8107-101-002 |
| RS0702 | 1.382 | 1.230 | .158 | .148 | 8107-101-002 |
| R-1001 | 1.763 | 1.610 | .158 | .148 | 8110-101-002 |
| R-1004 | 1.763 | 1.610 | .158 | .148 | 8110-101-002 |
| R-1002 | 1.763 | 1.610 | .158 | .148 | 8110-101-002 |
| RC1004 | 1.763 | 1.610 | .158 | .148 | 8110-101-002 |
| RK1004 | 1.763 | 1.610 | .158 | .148 | 8110-101-002 |
| RL1004 | 1.763 | 1.610 | .158 | .148 | 8110-101-002 |
| RS1001 | 1.763 | 1.610 | .158 | .148 | 8110-101-002 |
| R-1105 | 1.763 | 1.610 | .158 | .148 | 8111-101-002 |
| R-1504 | 2.163 | 2.050 | .158 | .148 | 8115-101-006 |

†Not for use with some ball nuts.

Wiper Kits

Type B

For these models, easy-to-install snap-in wiper kits prevent internal ball nut contamination which decreases performance and dynamic life ratings.

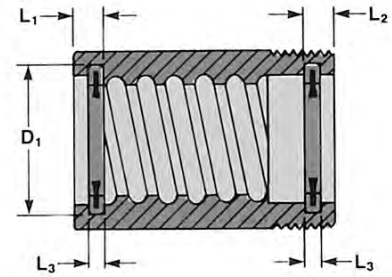

| MODEL | D ₁ NOM. | L ₁ NOM. | L ₂ NOM. | L ₃ NOM. | WIPER PART NUMBER |
|---------|------------------------|------------------------|------------------------|------------------------|----------------------|
| R-1501* | 2.096 | .200 | .190 | .130 | 8115-101-004 |
| RH1501* | 2.096 | .200 | .190 | .130 | 8115-101-004 |
| R-1520* | 2.096 | .200 | .190 | .130 | 8115-101-004 |
| RH1520* | 2.096 | .200 | .190 | .130 | 8115-101-004 |
| R-1547* | 2.096 | .200 | .190 | .130 | 8115-101-004 |
| R-1502* | 2.096 | .200 | .190 | .130 | 8115-101-004 |
| RL1502* | 2.096 | .200 | .190 | .130 | 8115-101-004 |
| R-2002* | 2.600 | .250 | .190 | .130 | 8120-101-002 |
| RL2002* | 2.600 | .250 | .190 | .130 | 8120-101-002 |
| R-2001* | 2.600 | .250 | .190 | .130 | 8120-101-002 |
| R-2202* | 2.793 | .220 | .190 | .130 | 8122-101-002 |
| R-2502* | 3.126 | .250 | .190 | .130 | 8125-101-002 |
| R-2501* | 3.126 | .250 | .190 | .130 | 8125-101-002 |
| R-3066* | 3.762 | .250 | .190 | .130 | 8130-101-002 |

* wiper kit standard with ball nut

Standard Mounting Flanges

For Bronze Nuts & Supernuts™

These mounting flanges are designed for easy mounting when fixed to a bronze nut or Supernut™.

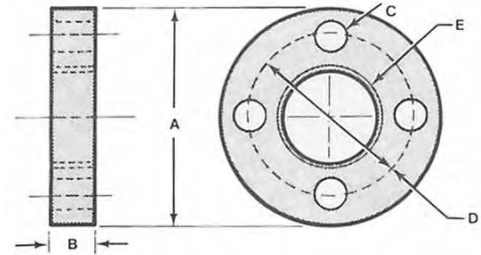

| ALUMINUM (6062-T6) FLANGES FOR BRONZE NUTS & SUPERNUTS™ | | | | | |
|---|-------------------|------------|-----------------|--------------------|-------------|
| PART NO. | FLANGE DIMENSIONS | | | | |
| | A DIAMETER | B WIDTH | C HOLE (NO.) | D B.C. DIAMETER | E THREAD |
| F25 | 1.25 | .187 | .140 (4) | 1.00 | 9/16-18 |
| F37 | 1.60 | .250 | .177 (4) | 1.24 | 5/8-18 |
| F50 | 2.00 | .375 | .266 (4) | 1.50 | 15/16-16 |
| F75 | 2.50 | .500 | .266 (4) | 2.00 | 1 3/8-16 |
| F100 | 3.00 | .600 | .266 (4) | 2.37 | 1 9/16-18 |

Aluminum flanges do not have a set screw which could deform the Supernut™ and possibly cause binding. Aluminum flanges should be pinned or bonded to Supernuts™ to prevent unwanted disassembly during operation.

Glossary/ Technical Data

| | |
|--|----|
| Critical Speed Limits Chart | 86 |
| Load Life Relationship Column Loading Capacities | 87 |
| Column Loading Capacities Chart | 88 |
| Glossary | 89 |
| Design Considerations | 92 |
| Warranties | 96 |

Critical Speed Limits Chart

For Ball Screws & Acme Screws

Every screw shaft has a rotational speed limit. That is the point at which the rotational speed sets up excessive vibration. This critical point is modified by the type of end bearing supports used.

To use this chart, determine the required RPM and the maximum length between bearing supports. Next, select one of the four types of end support shown below. The critical speed limit can be found by locating the point at which the RPM's (horizontal lines) intersects with the unsupported screw length (vertical lines) as modified by the type of supports select below. **We recommend operating at no more than 80% of the critical speed limit to allow for misalignment and/or lack of screw straightness.**

Warning: Curves for the screw diameters shown are based on the smallest root (minor) diameter of the standard screws within the nominal size range and truncated at the maximum ball nut rotational speed. **DO NOT EXCEED** this RPM regardless of screw length.

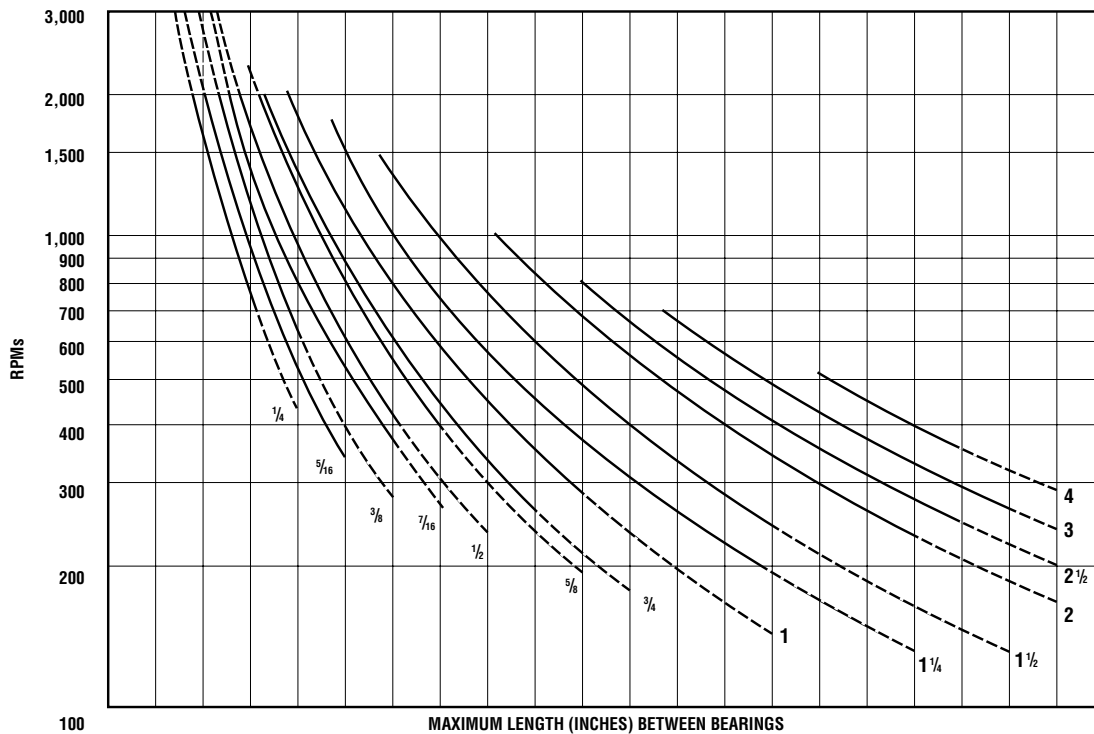

| | 6 | 12 | 18 | 24 | 30 | 36 | 42 | 48 | 54 | 60 | 66 | 72 | 78 | 84 | 90 | 96 | 102 | 108 | 120 | 126 |
|-------------------|----|----|----|----|----|----|-----|-----|-----|-----|-----|-----|-----|-----|-----|-----|-----|-----|-----|-----|
| (A) Fixed-Free | 6 | 12 | 18 | 24 | 30 | 36 | 42 | 48 | 54 | 60 | 66 | 72 | 78 | 84 | 90 | 96 | 102 | 108 | 120 | 126 |
| (B) Simple-Simple | 10 | 20 | 30 | 40 | 50 | 60 | 70 | 80 | 90 | 100 | 110 | 120 | 130 | 140 | 150 | 160 | 170 | 180 | 190 | 200 |
| (C) Fixed-Simple | 12 | 24 | 36 | 48 | 61 | 73 | 85 | 97 | 109 | 121 | 133 | 154 | 158 | 170 | 182 | 194 | 206 | 218 | 230 | 242 |
| (D) Fixed-Fixed | 15 | 30 | 45 | 60 | 75 | 90 | 105 | 119 | 134 | 149 | 164 | 179 | 194 | 209 | 224 | 239 | 254 | 269 | 284 | 298 |

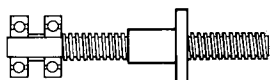

(A) Fixed-Free

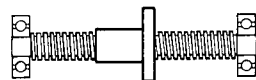

(B) Simple-Simple

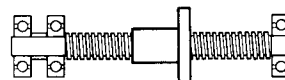

(C) Fixed-Simple

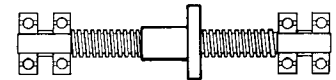

(D) Fixed-Fixed

Load Life Relationship Column Loading Capacities

For Ball Screws

Ball screws are rated for 1,000,000 inches of travel at the rated dynamic load. This is the load at which 90% of a group of identical ball screws will run without flaking for their lifetime. However, they will travel farther than this at lower limits. These load-life relationships are analogous to the B10 rating common in the ball bearing industry. The relationship of load to life is an inverse cube relation. For example, reducing the load by 1/2 increases life eight times. Doubling the load decreases life by 1/8. Every attempt should be made to design for loads that do not exceed the dynamic load rating of the nut. † Never exceed twice the rated dynamic load rating of the nut while in motion.

To use the load/life equation, look up the rated dynamic load for the assembly you are interested in. Use a diagram load that covers your typical worst case loading and compute the predicted theoretical design life as follows:

$$L = \left\langle \frac{Fr}{D \bullet f_w} \right\rangle^3 \times 1 \times 10^6$$

- L = life in inches
- D = Design Load
- Fr = Dynamic Load Rating
- f_w = 1.2–1.5 Nominal Operation
1.5–3.0 Operation with impact or vibration

Column Loading Capacities Chart

Use the chart on the following page to determine the Maximum Compression Load for Screw Shaft. Usually, screw operated in tension can handle loads up to the rated capacity of the nut, providing the screw length is within standard lengths. End supports have an effect on the load capacity of screws. The four standard variations are shown below with corresponding rating adjustments.

Find the point of intersecting lines of load (horizontal) and length (vertical) to determine the minimum safe diameter of screw. If loads fall into dotted lines consult factory.

Warning: Do not exceed ball nut capacity. Curves for the screw diameters shown are based on the smallest root (minor) diameter of the standard screws within the nominal size range.

† BSA assumes no liability for assemblies used at above the dynamic load rating of the nut.

Column Loading Capacities Chart

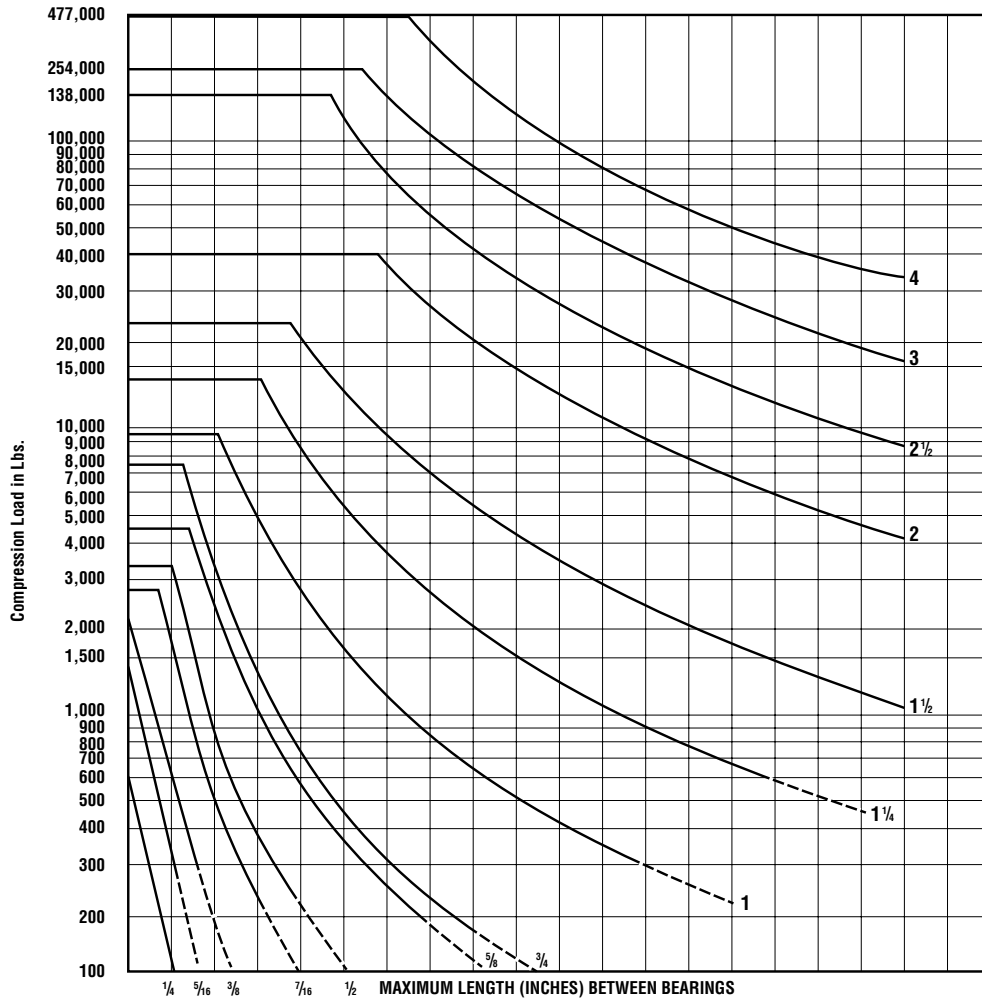

| | | | | | | | | | | | | | | | | | | | |
|-------------------|----|----|----|----|-----|-----|-----|-----|-----|-----|-----|-----|-----|-----|-----|-----|-----|-----|-----|
| (A) Fixed-Free | 5 | 10 | 15 | 20 | 25 | 30 | 35 | 40 | 45 | 50 | 55 | 60 | 65 | 70 | 75 | 80 | 85 | 90 | 95 |
| (B) Simple-Simple | 10 | 20 | 30 | 40 | 50 | 60 | 70 | 80 | 90 | 100 | 110 | 120 | 130 | 140 | 150 | 160 | 170 | 180 | 190 |
| (C) Fixed-Simple | 14 | 28 | 42 | 57 | 71 | 85 | 99 | 113 | 127 | 141 | 156 | 170 | 184 | 198 | 212 | 226 | 240 | 255 | 270 |
| (D) Fixed-Fixed | 20 | 40 | 60 | 80 | 100 | 120 | 140 | 160 | 180 | 200 | 220 | 240 | 260 | 280 | 300 | 320 | 340 | 360 | 380 |

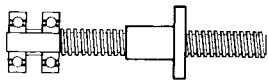

(A) Fixed-Free

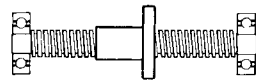

(B) Simple-Simple

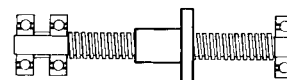

(C) Fixed-Simple

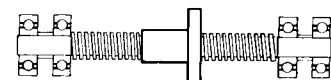

(D) Fixed-Fixed



Compression (Column) Load

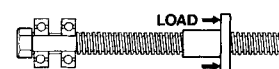

Tension (Pulling) Load

Glossary

General Definitions

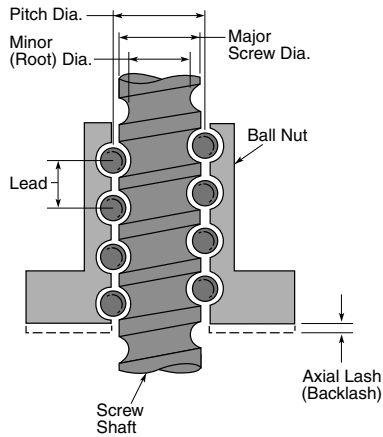

AXIAL LASH/BACKLASH

The axial free motion between the ball nut and screw; a measure of system stiffness.

BEARING BALL CIRCUIT

The closed path of recirculating balls within the ball nut assembly. A multiple circuit nut with two or more individual circuits has a greater load carrying capability than a single circuit ball nut assembly of the same diameter.

CYCLE

The complete forward and reverse motion of the screw (or nut) when moving the load. One cycle is equivalent to two load carrying strokes (one forward and one backward).

DIAMETER—MAJOR

The outside diameter of the ball bearing screw shaft. In dealing with ball bearing screws, this is the basic measurement.

DIAMETER—MINOR (ROOT)

Diameter of the screw measured at the bottom of the ball track.

DIAMETER—PITCH

The nominal diameter of a theoretical cylinder passing through the centers of the balls when they are in contact with the ball bearing screw and ball nut tracks.

EFFECTIVE BALL TURNS

The number of ball groove revolutions within the ball nut body; a ball nut with seven effective ball turns will have a higher load carrying capability than one with five, all other characteristics being equal.

LEAD

The axial distance a screw travels during one revolution.

LEAD TOLERANCE

The maximum variation from nominal, measured in inches per foot, cumulative.

LOAD CARRYING BALLS

The balls in contact with the ball grooves of both the nut and the screw for load carrying purposes.

RIGHT HAND THREAD

The direction of the threads on the screw shaft causing the ball nut to travel away from the end viewed when rotated in a counter clockwise direction.

SCREW STARTS

The integral number of independent threads on the screw shaft; typically one, two or four.

Ball Contact

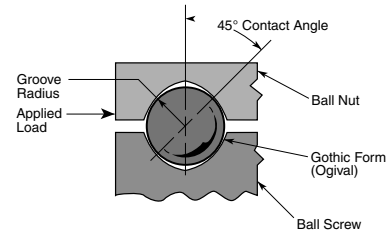

GOTHIC (OR OGIVAL) GROOVE

A ball track cross-section shaped like a Gothic arch.

CONFORMITY RATIO

Ratio of the ball track radius to the ball diameter.

CONTACT ANGLE

Nominal angle between a plane perpendicular to the screw and a line drawn between the theoretical points of tangency between a ball and the ball tracks and projected on a plane passing through the screw axis and the center of the ball. The angle at which the ball contacts the groove.

Glossary

Loading

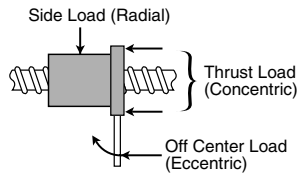

DYNAMIC LOAD RATING

Dynamic load rating is the maximum load which a ball bearing screw assembly can maintain for a prescribed length of travel.

STATIC LOAD

Static load is the maximum non-operating load capacity above which brinelling of the ball track occurs.

THRUST LOAD

Thrust load is loading parallel to and concentric with the centerline of the screw shaft which acts continuously in one direction. Thrust loading is the proper method of attaching the load to the ball bearing screw assembly.

PRELOAD

The use of one group of bearing balls set in opposition to another to remove axial lash or backlash and increase ball bearing screw stiffness. All axial freedom is eliminated in preloading.

TENSION LOAD

Tension load is a load which would tend to stretch the ball screw shaft.

COMPRESSION LOAD

Compression load is a load which would tend to compress or buckle the ball screw shaft.

OFF CENTER LOAD (ECCENTRIC)

A load tending to cock the ball nut on the screw, reducing the rated life. This must be considered in the selection of the ball bearing screw assembly.

SIDE LOAD (RADIAL)

A load from the side that will reduce the rated life and must be considered in the selection of the ball bearing screw.

Load/Life

A rolling contact device such as a ball bearing screw is said to have reached the end of its usable life at the first sign of fatigue on the rolling surfaces. Fatigue results from the repeated flexing of metal as the balls pass over any given point under load.

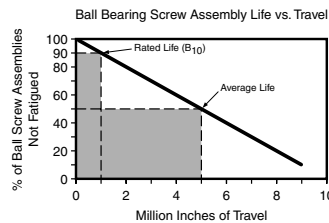

LOAD/LIFE RATING

The usable life of a ball bearing screw assembly measured in inches of travel under a specific load. The length of travel that 90 percent of a group of ball bearing screws will complete, or exceed, before the first evidence of fatigue develops. (B10)

MOUNTING-ENDS

END BEARING SUPPORT (END FIXITY)

The three basic bearing configurations that are commonly used to support the ends of a ball screw are:

- A single journal or ball type bearing (simple support).



- A pair of back-to-back, angular contact bearings to control end play (simple support).



- A pair of spaced bearings for added rigidity (rigid support).



Four combinations of bearing supports are used throughout this catalog for selection purposes. They are:

RIGID (least support) FREE

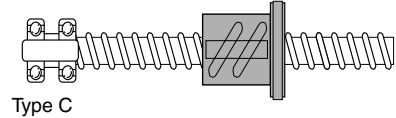

SIMPLE RIGID SIMPLE

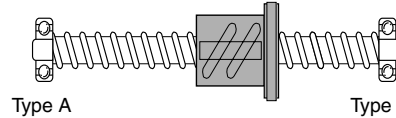

RIGID RIGID SIMPLE

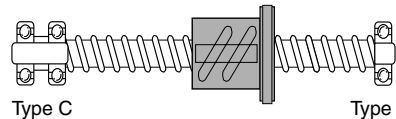

RIGID RIGID RIGID

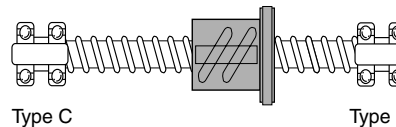

ANNEALED ENDS

A manufacturing process which removes brittleness while softening screw stock to allow for machining of end journals.

Glossary

Backdriving

Ball bearing screws can be backdriven. A load on the nut will drive the screw because of the inherent high efficiency (90%).

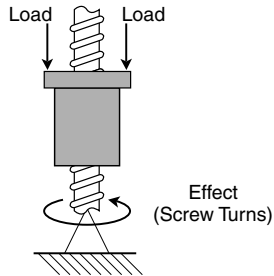

If backdriving is required in a particular application, the lead of the screw should be at least one third the screw diameter. Ideally the lead should be equal to the screw diameter.

DRIVING TORQUE

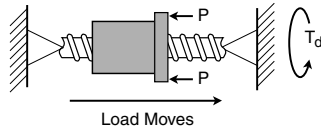

The amount of effort, measured in pound-inches, required to turn the ball screw and move the load.

$$T_d = \frac{P \times L}{2 \pi e} = .177 P \times L \text{ (lb-inches)}$$

T_d = Direct Torque (lb-inches)

P = Load

L = Screw Lead (inches/turn)

e = Ball Bearing Screw Efficiency (90%)

BACKDRIVING TORQUE

The backdriving torque (T_b) is the torque created by an applied load.

$$T_b = .143 (P) (L) = \text{in-lbs}$$

PRELOAD TORQUE

$$T_{PL} = \frac{P_{PL} \times L \times .2}{2\pi}$$

or

$$T_{PL} = .032 \times P_{PL} \times L$$

T_{PL} = Torque (lb-inches)

P_{PL} = Preload setting (pounds)

L = Lead

ANGULAR VELOCITY

$$\text{RPM} = \frac{\text{Velocity (inches/min.)}}{\text{Lead (inches/rev.)}}$$

HORSEPOWER

$$\text{HP} = \frac{\text{RPM} \times \text{Torque (in-lbs)}}{63,000}$$

ROTATIONAL TORQUE

To accelerate the screw

$$T_r = \frac{WR^2 (\text{RPM})}{3700 (t)} = \text{lb-in}$$

T_r = Torque (lb-in)

WR^2 = Inertia (lb-in)

t = Time to accelerate (sec.)

ACCELERATION TORQUE

Under load

$$T_a = \frac{(p/g) (A) (L)}{2\pi e} = \text{lb-in}$$

A = Acceleration (in/sec²)

g = 386 in/sec²

p = Load (lb)

L = Screw lead (in/turn)

Thermal expansion of screw

$$= 6.25 \times 10^{-6} \text{ in/in/}^\circ\text{F}$$

Design Considerations

Most Frequently Asked Questions About Ball Screws

QUESTION How do you restrict the flange from turning off the nut in reversing load applications?

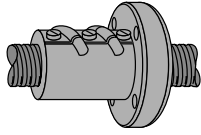

ANSWER The flange may be held to the nut by three alternative methods:

a) The most positive method of holding the flange to the nut is to order factory “drill and pin” prior to bearing loading. The flange and nut are drilled to accept a roll pin from the flange face.

b) The flange may be drilled and tapped from the O.D. into the nut threads. A carbide spade drill may be used to drill into the hardened nut threads. Avoid getting metal chips into the nut.

c) Commercially available adhesives such as Loctite may be used. Take care to avoid getting adhesive on the ball track. (Light loads only).

QUESTION How do you calculate application life requirement in inches?

ANSWER Each ball bearing screw application will have an expected life given the stroke length, duty cycle, years of required service and load.

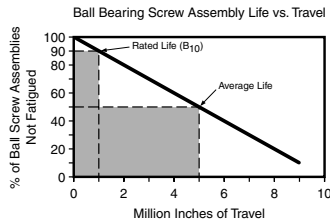

a) Life expectancy is the total inches of travel that an assembly will provide under a stated load. (Life is sensitive to load.) Use the Load Life Relationship on page 87 to calculate the expected life of a particular assembly in inches.

b) To determine the inches of required life: multiply inches of stroke x two (only on vertical applications) x cycles per hour x hours of operation per day x number of working days per year x years of expected service.

c) Compare the expected life to the required life. Expected life can be increased by choosing a ball screw with a larger load rating.

QUESTION Is lubrication necessary?

ANSWER Proper and frequent lubrication must be provided for satisfactory service and life. A 90% reduction in ball bearing screw life should be allowed where dry operation is unavoidable. Lubricants reduce abrasive wear and dissipate heat caused by metal-to-metal contact between bearing surfaces. See page 80 for BSA lubricants.

QUESTION How are torque requirements for preload nuts calculated?

ANSWER Driving torque increases only slightly with preload since a preload unit continues to be highly efficient.

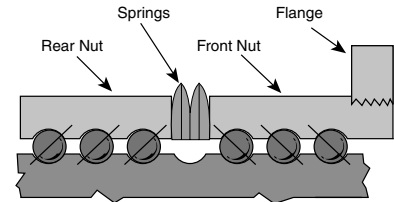

First, determine the driving torque for a single nut working at a given load. Second, determine the torque required for the preload load setting. Add the driving torque and preload torque together to determine total torque requirement.

QUESTION What is meant by lead error?

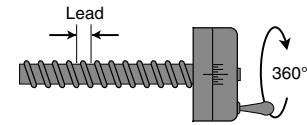

ANSWER Lead error is the average deviation from the nominal lead that occurs in one foot of nut displacement. Most screws are offered in standard and precision grades. (See pages 29 – 49 for more details.)

Design Considerations

QUESTION How are ball bearing screws synchronized?

ANSWER Screw synchronizing is achieved by selecting screws with similar lead error, and driven by a positive single source drive. “Matched sets required” should be specified when ordering screws that should be timed to run together without binding because of lead mis-match. (Special factory order).

QUESTION What can be done to exceed calculated critical speed?

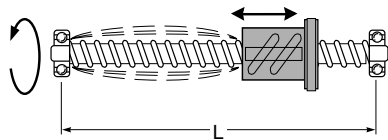

ANSWER The chart for critical speed is on page 86. Critical speed is a function of unsupported screw length, mean diameter of screw and bearing supports. Rigid/rigid screw mounting is the optimum support for high speeds. Consider a faster lead to reduce the RPM required. If higher speed is still necessary, go to a larger diameter screw.

QUESTION What is the difference between pitch and lead?

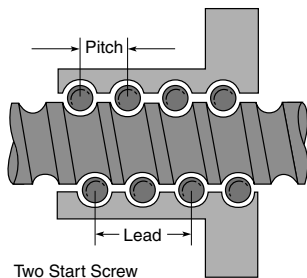

ANSWER Pitch is the measurable distance between screw grooves. Lead is the linear travel the nut makes per screw revolution. The pitch and lead are equal with single start screws. The pitch is 1/2 the lead in two start screws, etc.

QUESTION What is the standard straightness on machined screws with standard ends or screws machined to customer prints?

ANSWER The threaded portion is .005 T.I.R. per foot and not to exceed .010 T.I.R. total length of screw.

QUESTION What is meant by tangential design nuts?

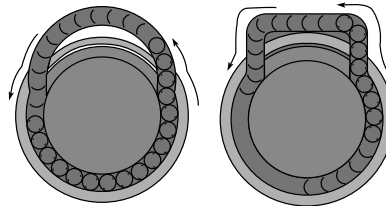

ANSWER The tangential circuit (Fig. 1) consists of a pickup finger (or yoke deflector) geometry which allows the circuit balls to enter and leave the load carrying portion of the ball screw circuit in a straight line path—along the tangent to the pitch diameter.

The standard ball nut design (Fig. 2) places the return tube holes closer together resulting in a circuit which requires a change in direction of the ball travel as the return tubes are entered and exited.

QUESTION What is the backlash of single nuts?

ANSWER The backlash range in a single nut is as follows:

| Model | Max. Backlash |
|------------------|---------------|
| R-0308 to R-0705 | .007" |
| R-0702 to R-1105 | .009" |
| R-1501 to R-1502 | .013" |
| R-2202 to R-2502 | .015" |
| R-3066 | .018" |

QUESTION Can backlash be minimized?

ANSWER Yes, backlash can be minimized or eliminated completely by using a preloaded ball bearing screw. See pages 32, 36, and 40.

QUESTION What is a load locking spring and how does it work?

ANSWER The load locking spring is a coil that is turned into the inactive portion of the nut and conforms to the ball track. The spring does nothing in normal operation and does not touch the screw. In the event the ball bearings are lost from the nut, the load locking spring will not allow the load carrying nut to free-fall down the screw.

Design Considerations

QUESTION Where is the lube hole in the large size nuts and what is the thread size?

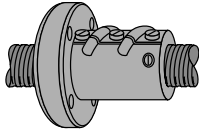

ANSWER A 1/8-27 NPT pipe thread tapped hole is standard on most nuts from R-1502 through R-3066.

QUESTION How do you size a ball bearing screw?

ANSWER Select the screw that will satisfy the most critical requirement of the application, such as high RPM, heavy load, duty cycle, column loading or zero backlash. Design for the worst case. See page 30.

QUESTION How is a hardened screw annealed?

ANSWER The ball bearing screws are case hardened to Rockwell C56 minimum. The screw ends are coil annealed after they are cut to length to reduce the case hardness to a machinable state. Screws may be annealed in the field by heating the ends to a cherry red with a torch, then putting the ends in sand to cool.

QUESTION How should ball bearing screws be protected from dirt and contaminants?

ANSWER The brush wipers help prohibit contaminants from entering the nut as it translates along the screw. For heavily contaminated environments, metal shields, bellow type enclosures or extensions are recommended to be used with wipers.

QUESTION What causes premature failure?

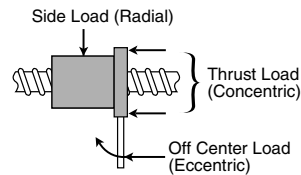

ANSWER Premature failure may be caused by any of the following:

- Misalignment of ball nut to screw which results in side loading or eccentric loading will reduce life. This may cause the bearing balls to split or get flats on them. The bearings may even break out of the tubes.
- Metal Chips or Dirt in the ball nut will not allow the bearings free circulation. The bearing balls may get flats on them because of skidding and spalling.
- Lack of Lubrication Proper lubrication will help dissipate heat and reduce metal-to-metal wear of components.
- High speed operation Shaft speeds resulting in screw surface speeds above 8,000 IPM will reduce rated life.

QUESTION What is the normal operating temperature range for ball bearing screws?

ANSWER The normal operating temperature range is -65°F to 300°F (-55°C to 149°C) with suitable lubrication. Temperatures in excess of this may make the screw brittle, warped or annealed.

Warranties

Exclusions & Limitations

The specifications for Seller's products published in Seller's catalogs or other printed material are for reference only. The performance rating figures do not constitute a warranty. All ratings are based on use in a normal environment under normal conditions. Such things as temperature extremes, eccentric or side loading, dirty conditions, extreme travel speeds, inadequate or faulty support and/or mounting provisions, lack of lubrication and maintenance, can and will derate the catalog ratings.

Should any failure occur during the first sixty days or the first 100,000 inches of travel, whichever comes first, due to a defect in material or workmanship in any product, if written notice is received from the buyer for any such alleged defect and if the product is found not to be in conformity with this warranty (buyer having provided Seller a reasonable opportunity to perform any appropriate tests thereon), Seller will replace or repair the product(s) provided (i) misuse or misapplication has not caused the failure and (ii) a complete inspection of the product and application thereof have been made by Seller. Claims must be made within 90 days after the date of shipment.

Parts and accessories or products not of Seller's manufacture are warranted as to defects in material and workmanship consistent with the warranty policy of the original manufacturer.

Modification or alteration of any product not specifically authorized by Seller will void any warranty whatsoever. Products used in conjunction with nuclear devices or their support systems are specifically excluded from any warranty.

SELLER'S LIABILITY UNDER THE FOREGOING WARRANTIES OR ANY OTHER WARRANTY, WHETHER EXPRESSED OR IMPLIED, IN LAW OR FACT, SHALL BE LIMITED TO THE REPAIR OR REPLACEMENT OF DEFECTIVE MATERIAL AND WORKMANSHIP AND IN NO EVENT SHALL SELLER BE LIABLE FOR CONSEQUENTIAL OR INDIRECT DAMAGES. THE ABOVE WARRANTY COMPRISES SELLER'S SOLE AND ENTIRE WARRANTY OBLIGATION AND LIABILITY IN CONNECTION WITH SELLER PRODUCTS SOLD HEREUNDER. ALL OTHER WARRANTIES, EXPRESS OR IMPLIED, INCLUDING BUT NOT LIMITED TO, WARRANTIES OF MERCHANTABILITY AND FITNESS FOR A PARTICULAR PURPOSE, ARE EXPRESSLY EXCLUDED.

SOME USEFUL FORMULAS FOR LEADSCREW ASSEMBLIES

TORQUE, ROTARY TO LINEAR

Driving the screw to translate the nut, or driving the nut to translate the screw.

BALL SCREW ASSEMBLIES

$$\text{Torque (in lbs)} = .177 \times \text{Load (lbs)} \times \text{Lead (inches)}$$

ACME SCREW ASSEMBLIES

$$\text{Torque (in lbs)} = \frac{\text{Load (lbs)} \times \text{Lead (inches)}}{2\pi \times \text{efficiency}^*}$$

*Acme screw efficiency is variable with the helix angle of the threads, the friction of the material and the finish. See the efficiency formula below.

TORQUE, LINEAR TO ROTARY

Driving the screw to translate the nut, or driving the nut to translate the screw.

BALL SCREW ASSEMBLIES

$$\text{Torque (in lbs)} = .143 \times \text{Load (lbs)} \times \text{Lead (inches)}$$

ACME SCREW ASSEMBLIES

$$\text{Torque (in lbs)} = \frac{\text{Load} \times \text{Lead} \times \text{Efficiency}}{2\pi}$$

The higher the lead of the screw the less effort required to backdrive either the screw or the nut. As a rule, the lead of the screw should be more than 1/3 the diameter of the screw to satisfactorily backdrive.

EFFICIENCY

BALL SCREW ASSEMBLIES

Most ball screw assemblies are better than 90% efficient. A preload will cause a decrease in efficiency.

ACME SCREW ASSEMBLIES

$$\% \text{ Efficiency} = \frac{\tan(\text{helix angle})}{\tan(\text{helix angle} + \arctan f)} \times 100$$

f = coefficient of friction

HORSEPOWER

TORQUE TO HORSEPOWER

$$\text{HP} = \frac{\text{Torque (in lbs)} \times \text{RPM}}{63,000}$$

HORSEPOWER TO TORQUE

$$\text{Torque} = \frac{63,000 \times \text{HP}}{\text{RPM}}$$

COLUMN LOAD STRENGTH

(Based on Eulers Formula)

$$P_{Cr} = \frac{14.03 \times 10^6 F_C d^4}{L^2}$$

P_{Cr} = maximum load (lbs)

F_C = end support factor (see page 31)

.25 one end fixed, other free

1.00 both ends supported

2.00 one end fixed, other supported

4.00 both ends fixed

d = root diameter of screw (in)

L = distance between nut and load carrying bearing (in)

When possible, design for tension loads to eliminate the buckling factor and reduce the required screw size.

CRITICAL SCREW SHAFT SPEED

(Maximum rotational speed of a screw)

$$C_S = F \times 4.76 \times 10^6 \times \frac{d}{L^2}$$

C_S = Critical Speed (rpm)

d = root diameter of screw (in)

L = length between supports (in)

F_C = end support factor (see page 31)

.36 one end fixed, other free

1.00 both ends supported

1.47 one end fixed, other supported

2.23 both ends fixed

Critical shaft speed should be reduced to 80% to allow for other factors such as alignment and straightness.

