

TECNOTION[®]

THE LINEAR MOTOR COMPANY

Iron Core & Ironless Linear Motor Series

Sold & Serviced By:

 **ELECTROMATE**

Toll Free Phone (877) SERV098

Toll Free Fax (877) SERV099

www.electromate.com

sales@electromate.com

QUALITY AND SERVICE DELIVERED WORLDWIDE

[TECNOTION]

Tecnotion is *the* global authority on linear motor technology. We are the world's only unbundled manufacturer of linear motors. A former part of Philips, we specialize solely in the development and production of linear motors. Because of this, our expertise, customer service and product quality are unmatched.

We have a global presence, with production plants in The Netherlands and China and local representation around the world. This ensures short delivery times and high quality support, wherever you are located.

When you do business with Tecnotion, you have a team of highly skilled sales and application engineers at your disposal. They help you from your initial prototype all the way to the application of our products and beyond.

Whatever your needs are, you can count on Tecnotion as a solid, reliable partner.



Sold & Serviced By:



Toll Free Phone (877) SERV098

Toll Free Fax (877) SERV099

www.electromate.com

sales@electromate.com



[SALES SUPPORT]

At Tecnotion we understand that each application of our linear motors is a unique case with specific requirements and demands.

Our sales and application engineers have extensive experience with a wide range of application types and collaborate on a high level with our customers to make sure you get the solution that best fits your requirements.

Additionally our specialized Simulation Tool is available to help you find your way through our wide range of linear motors and analyze/test out different motor types within your application specifications.

[INNOVATION]

We have an in-house R&D department, which is continuously pushing the boundaries of technology and taking our products to the next level. This translates directly to our high level of understanding of manufacturing processes.

Apart from our “off-the-shelf” range of standard linear motors, we can also design and manufacture custom made motors for high profile projects or OEM applications that require a tailor-made solution.

All our custom motors are built to the same high standards that characterize our standard range of products.



[MANUFACTURING]

Manufacturing of our standard range of motors takes place at our modern plant in China, where we are able to produce in high volume at very competitive rates.

At our competence centre and headquarters in The Netherlands we specialize in advanced technology. This is where we do our research and development and where custom motors are built with extreme accuracy in our special state of the art cleanroom environment.

Tecnotion is committed to excellence. Both of our plants are ISO 9001 certified and comply to the highest quality standards possible.

[GLOBAL LOGISTICS]

We always have our most popular products in stock in our warehouses in both The Netherlands and China. Our logistics department can ship directly to you from both locations, making very short delivery times possible across the globe, even when markets are ramping.

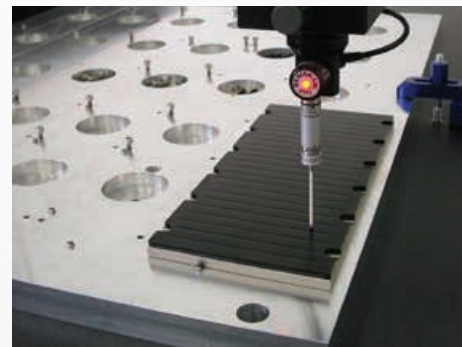

Sold & Serviced By:

 **ELECTROMATE**

Toll Free Phone (877) SERV098

Toll Free Fax (877) SERV099

www.electromate.com

sales@electromate.com

Iron Core Motors

Sold & Serviced By:



Toll Free Phone (877) SERV098
Toll Free Fax (877) SERV099
www.electromate.com
sales@electromate.com

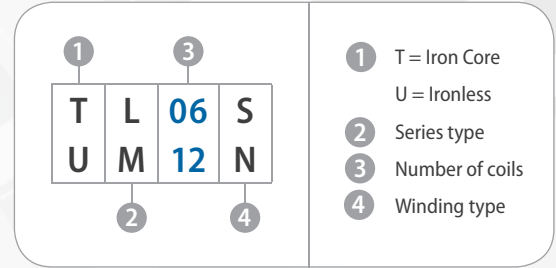

TBW Series

Fp 2700..6750N Fc 1200..3000N

The TBW series is the water cooled variant of the TB series. It features a fully integrated, highly efficient cooling system which enables the TBW to reach even higher continuous forces than the standard version and sustain extreme accelerations while maintaining its submicron position accuracy. Since heat is not dissipated into the machine's construction, it is especially suited for applications where thermal management is an issue.

TB Series

Fp 1800..4500N Fc 760..1900N

The high-end TB motors are heavy duty workhorses that combine high acceleration and speed, submicron positioning accuracy and low power consumption with a superb force density. They excel in applications where high loads and long duty cycles are the order of the day. When you require a motor that takes your application to new levels, the TB more than delivers.

TL Series

Fp 450..1800N Fc 200..840N

The mid-range TL is our most popular iron core motor. It features an extremely low attraction force between the coils and the magnets and stands out for its small size, high acceleration, high speed and accuracy. The TL is also available in long versions, which makes this all-rounder suited for nearly any application, including those with long travel lengths, like printers for large digital formats.

TM Series

Fp 120..480N Fc 60..240N

For applications that do not require high forces, it is often more effective to use a smaller and less costly motor. Over the years, the TM series has proven to be a very versatile, reliable and efficient motor for a wide range of applications. To enhance its effectiveness, the TM linear motor is equipped with a long flexible servocable which makes the use of additional connectors superfluous and reduces total cost of ownership even further.

Ironless Motors

Sold & Serviced By:



Toll Free Phone (877) SERV098
 Toll Free Fax (877) SERV099
www.electromate.com
sales@electromate.com

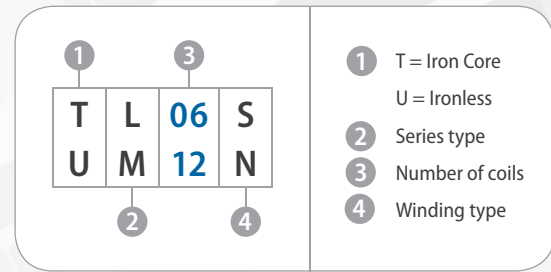

UXX / UXA Series

Fp 615..4200N Fc 120..846N

The UXX is the most powerful standard ironless motor we have to offer. It is ideal for heavy duty industrial applications that demand ultra precision and maximum force output. The UXA is the economical alternative to the UXX. It's slightly less powerful, but makes up for this with a smaller footprint and an attractive price tag.

UL Series

Fp 240..960N Fc 70..280N

The high-end UL ironless motors are available in various configurations that can easily be adapted to application specific requirements. Because of their high speed, positioning accuracy, zero cogging and attraction force, many UL motors are successfully applied throughout the semiconductor industry.

UM Series

Fp 100..400N Fc 29..116N

The mid-range UM ironless motors stand out for their extremely high speed and exceptional thermal characteristics which are the result of our unique production techniques. This makes the compact UM motors especially suited for applications in which highly accurate measuring is required.

UF Series

Fp 42.5..85N Fc 19.5..39N

The UF Series is built specifically to sustain very high continuous forces for its footprint, which is only marginally larger than that of the UC. It is exceptionally suited for applications with high duty cycles, for instance in the medical and semiconductor markets or for pick & place systems.

UC Series

Fp 36..72N Fc 10..20N

The UC is our smallest "off the shelf" motor. Weighing in at just a few grams, this versatile, compact and affordable motor is still able to sustain a continuous force of 10 or 20N. Due to its low weight it is also suited to operate in a vertical application environment.

Mounting instructions and flatness or parallelism requirements can be found in the Iron Core installation manual. CAD files and 3D models can be downloaded from our website.

MAGNET PLATES

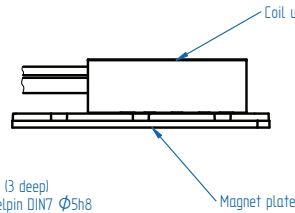
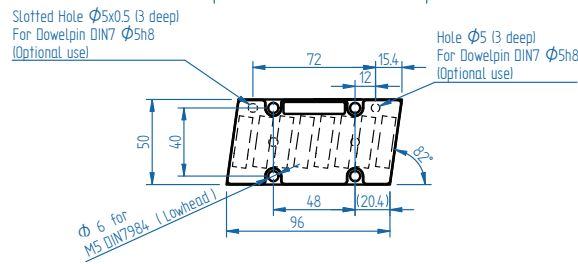
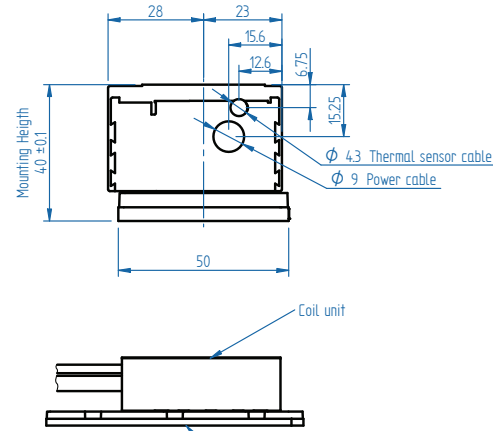

COIL UNITS

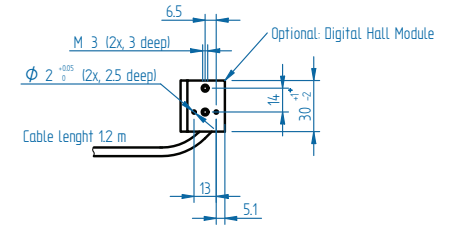

TM 3

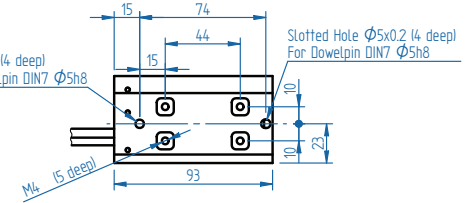

TM 6

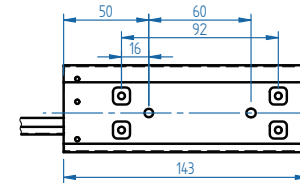

TM 12

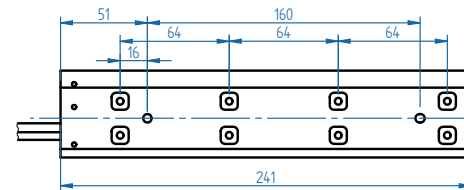

Sold & Serviced By:



TM 96mm

Toll Free Phone (877) SERV098
Toll Free Fax (877) SERV099
www.electromate.com
sales@electromate.com

2x TM 144mm

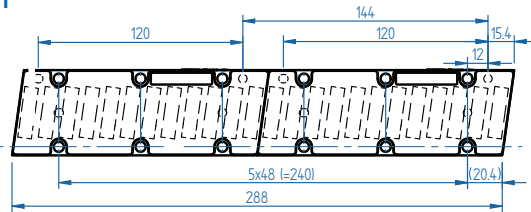

TM 384mm

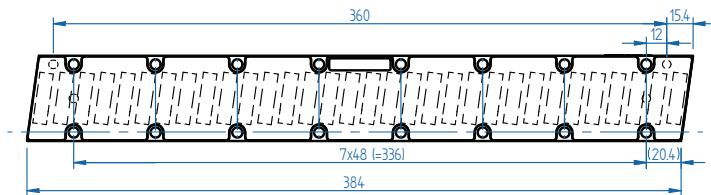

	Parameter	Remarks	Symbol	Unit	TM3	TM6	TM12
Performance	Winding type				S	S	S
	Motortype, max voltage ph-ph	3-phase synchronous Iron core, 400V _{ac rms} (600V _{dc})					
	Ultimate Force @ 10°C/s increase	magnet @ 25°C	F _u	N	120	240	480
	Peak Force @ 6°C/s increase	magnet @ 25°C	F _p	N	105	210	420
	Continuous Force*	coils @ 100°C	F _c	N	60	120	240
	Maximum Speed**	@ 600 V	v _{max}	m/s	12	12	12
	Motor Force Constant	mount. sfc. @ 20°C	K	N/A _{rms}	39	39	39
	Motor Constant	coils @ 25°C	S	N ² /W	95	190	380
Electrical	Ultimate Current	magnet @ 25°C	I _u	A _{rms}	4.1	8.2	16.4
	Peak Current	magnet @ 25°C	I _p	A _{rms}	3.1	6.2	12.4
	Maximum Continuous Current*	coils @ 100°C	I _c	A _{rms}	1.5	3	6
	Back EMF Phase-Phase _{peak}		B _{emf}	V / m/s	32	32	32
	Resistance per Phase*	coils @ 25°C ex. cable	R _{ph}	Ω	5.4	2.7	1.35
	Induction per Phase	l < 0.6 Ip	L _{ph}	mH	35	17	9
	Electrical Time Constant*	coils @ 25°C	τ _e	ms	6.5	6.5	6.5
Thermal	Maximum Continuous Power Loss	all coils	P _c	W	49	99	197
	Thermal Resistance	coils to mount. sfc.	R _{th}	°C/W	1.5	0.75	0.38
	Thermal Time Constant*	to max. coil temp.	τ _{th}	s	75	75	75
Mechanical	Temperature Cut-off / Sensor				PTC 1kΩ / KTY83-122		
	Coil Unit Weight	ex. cables	W	kg	0.6	0.9	1.6
	Coil Unit Length	ex. cables	L	mm	93	143	241
	Motor Attraction Force	rms @ 0 A	F _a	N	300	500	900
	Magnet Pitch NN		τ	mm	24	24	24
	Cable Mass		m	kg/m	0.18	0.18	0.18
	Cable Type (Power FLEX)	length 3 m	d	mm (AWG)	9.0 (21)		
	Cable Type (Sensor)	length 3 m	d	mm (AWG)	4.3 (26)		
	Cable Life (Power FLEX)***	minimum			5,000,000 cycles		
	Bending Radius Static	minimum			4x cable diameter		
Bending Radius Dynamic	minimum			10x cable diameter			

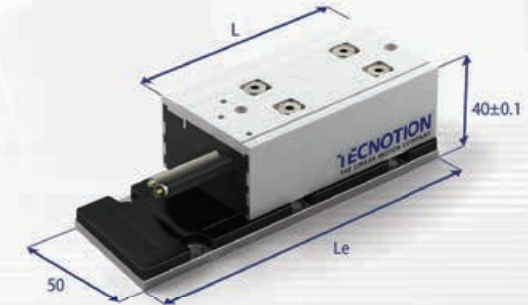

TM3 on 144mm magnet plate shown

Approvals



FLEX Cable

The TM series comes standard with a 3m long FLEX power cable.

Magnet plate dimensions

Le (mm)	96	144	384
M5 bolts	4	6	16
Mass (kg/m)	2.1		

Magnet plates can be butted together.

All specifications ±10%

* These values are only applicable when the mounting surface is at 20°C and the motor is driven at maximum continuous current. If these values differ in your application, please check our simulation tool.

** Actual values depend on bus voltage. Please check the F/V diagram in our simulation tool.

*** Depending on Bending Radius, Velocity and Acceleration.

**** Production date end of 2013.

	Parameter	Remarks	Sym	Unit	TL6		TL9		TL12		TL15		TL18		TL24	
					N	S	N	S	N	S	N	S	N	S	N	S
Performance	Winding type				N	S	N	S	N	S	N	S	N	S	N	S
	Motortype, max voltage ph-ph				3-phase synchronous Iron core, 400V _{ac rms} (600V _{dc})											
	Ultimate Force @ 10°C/s increase	magnet @ 25°C	F _u	N	450	675	900	1125	1350	1800						
	Peak Force @ 6°C/s increase	magnet @ 25°C	F _p	N	400	600	800	1000	1200	1600						
	Continuous Force Watercooled*	coils @ 100°C	F _{cw}	N	210	315	420	525	630	840						
	Continuous Force Aircooled*	coils @ 100°C	F _c	N	200	300	400	500	600	800						
	Maximum Speed**	@ 560 V	V _{max}	m/s	3.5	7	4	7	3.5	7	3.5	7	3.5	7	3.5	7
	Motor Force Constant	mount. sfc. @ 20°C	K	N/A _{rms}	93	46.5	140	46.5	93	46.5	112	46.5	93	44.9	93	46.5
Motor Constant		S	N ² /W	380	570	760	950	1140	1520							
Electrical	Ultimate Current	magnet @ 25°C	I _u	A _{rms}	6.5	13.1	6.5	19.6	13.1	26.2	13.5	32.7	19.6	41	26.2	52
	Peak Current	magnet @ 25°C	I _p	A _{rms}	5.0	10.0	5.0	15.0	10.0	20.0	10.4	25.0	15.0	31.0	20.0	40.0
	Continuous Current Watercooled*	coils @ 100°C	I _{cw}	A _{rms}	2.26	4.5	2.26	6.8	4.5	9.0	4.7	11.3	6.8	14.0	9.0	18.1
	Back EMF Phase-Phase _{peak}		B _{emf}	V / m/s	76	38	114	38	76	38	92	38	76	38	76	38
	Resistance per Phase*	coils @ 25°C ex. cable	R _{ph}	Ω	7.2	1.80	10.8	1.21	3.6	0.90	4.3	0.72	2.41	0.59	1.81	0.46
	Induction per Phase	l < 0.6 lp	L _{ph}	mH	54	14	81	9.0	27	7.0	32	5.4	18	4.4	14	3.4
	Electrical Time Constant*	coils @ 25°C	τ _e	ms	7.5	7.5	7.5	7.5	7.5	7.5	7.5	7.5	7.5	7.5	7.5	7.5
Thermal	Maximum Continuous Power Loss	all coils	P _c	W	150	225	300	375	450	600						
	Thermal Resistance	coils to mount. sfc.	R _{th}	°C/W	0.48	0.32	0.24	0.19	0.16	0.12						
	Thermal Time Constant*	to max. coil temp.	τ _{th}	s	77	77	77	77	77	77						
	Watercooling Flow	for ΔT=3K	Φ _w	l/min	0.7	1.1	1.4	1.8	2.2	2.9						
	Watercooling Pressure-drop	order of magnitude	ΔP _w	bar	1	1	2	2	2	3						
	Temperature Cut-off / Sensor				PTC 1kΩ / KTY83-122											
Mechanical	Coil Unit Weight	ex. cables	W	kg	1.5	2.0	2.6	3.2	3.8	5.2						
	Coil Unit Length	ex. cables	L	mm	146	194	244	290	336	468						
	Motor Attraction Force	rms @ 0 A	F _a	N	950	1325	1700	2075	2450	3400						
	Magnet Pitch NN		τ	mm	24	24	24	24	24	24						
	Cable Mass		m	kg/m	0.18	0.18	0.18	0.18	0.18	0.30						
	Cable Type (Power)	length 1 m	d	mm (AWG)					9.6 (18)					11.9 (14)		
	Cable Type (Sensor)	length 1 m	d	mm (AWG)					4.3 (26)					4.3 (26)		

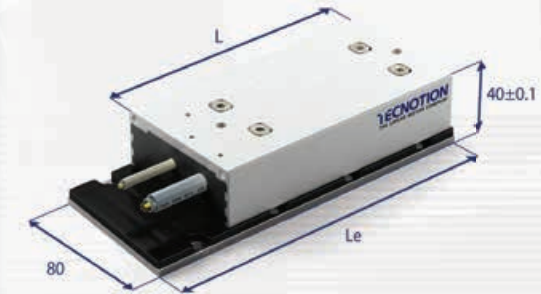

TL6 on 192mm magnet plate shown

Approvals



Water cooling

All TL motors feature integrated cooling channels that allow for the easy setup of a liquid cooled system, at no additional cost.

Magnet plate dimensions

Le (mm)	192	288
M5 bolts	8	12
Mass (kg/m)	3.8	

Magnet plates can be butted together.

All specifications ±10%

* These values are only applicable when the mounting surface is at 20°C and the motor is driven at maximum continuous current. If these values differ in your application, please check our simulation tool.

** Actual values depend on bus voltage. Please check the F/V diagram in our simulation tool.

***Production date end of 2013.

Mounting instructions and flatness or parallelism requirements can be found in the Iron Core installation manual. CAD files and 3D models can be downloaded from our website.

MAGNET PLATES

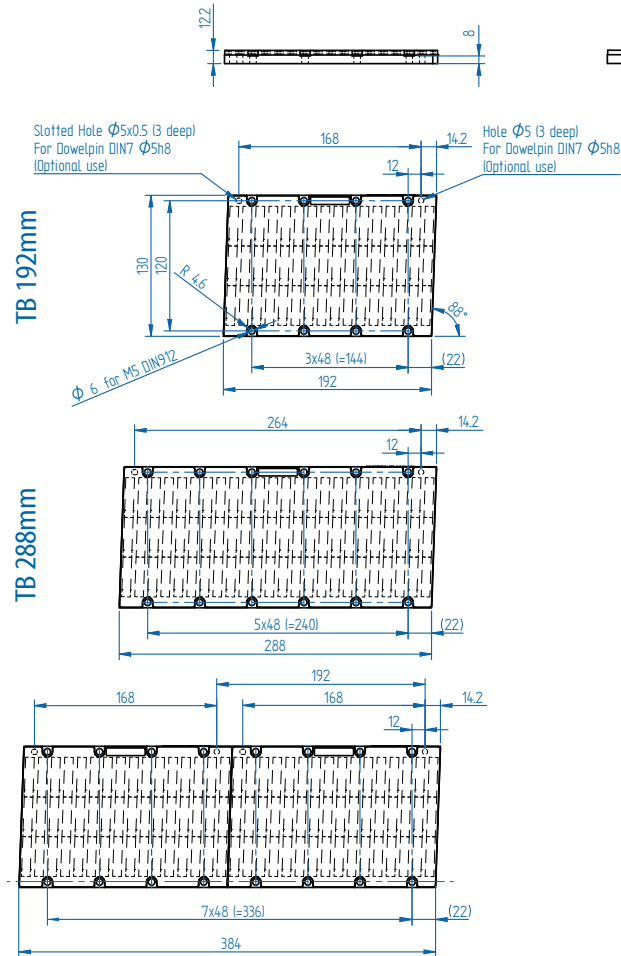
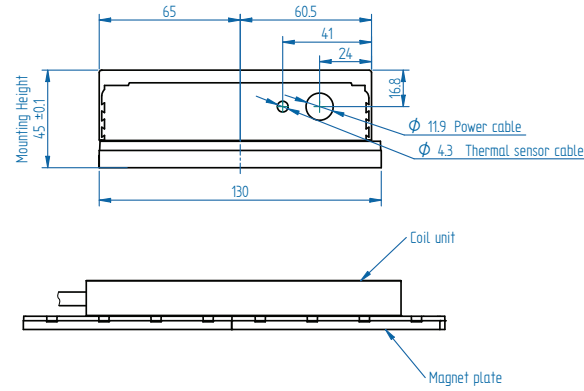

COIL UNITS

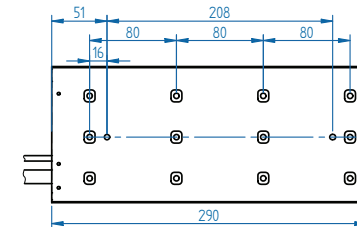
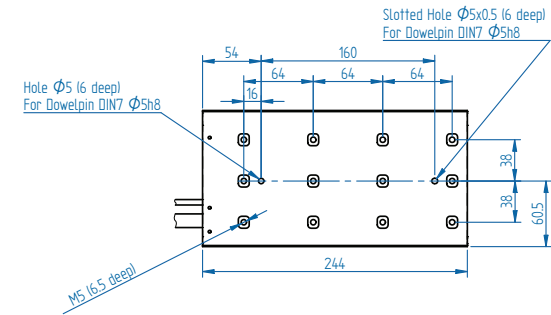
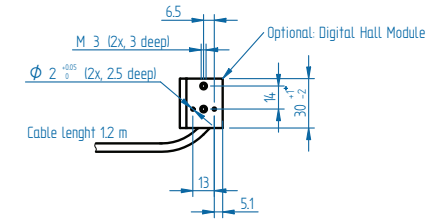

TB30

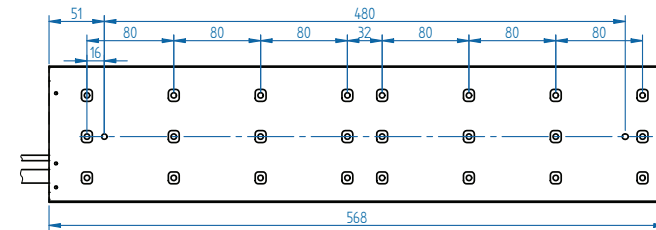

Parameter	Remarks	Symbol	Unit	TB12		TB15		TB30	
Winding type				N	S	N	S	N	S
Motor type, max voltage ph-ph				3-phase synchronous Iron core, 400V _{ac rms} (600V _{dc})					
Ultimate Force @ 10°C/s increase	magnet @ 25°C	F _u	N	1800		2250		4500	
Peak Force @ 6°C/s increase	magnet @ 25°C	F _p	N	1600		2000		4000	
Continuous Force*	coils @ 100°C	F _c	N	760		950		1900	
Maximum Speed**	@ 560 V	v _{max}	m/s	3	6	2.5	6	2.5	6
Motor Force Constant	mount. sfc. @ 20°C	K	N/A _{rms}	186	93	225	93	225	93
Motor Constant	coils @ 25°C	S	N ² /W	1750		2150		4300	
Ultimate Current	magnet @ 25°C	I _u	A _{rms}	13.0	26	13.5	33	27	66
Peak Current	magnet @ 25°C	I _p	A _{rms}	10.0	20	10.0	25	20	50
Maximum Continuous Current	coils @ 100°C	I _c	A _{rms}	4.1	8.2	4.2	10.2	8.5	20.5
Back EMF Phase-Phase _{peak}		B _{emf}	V / m/s	152	76	183	76	183	76
Resistance per Phase*	coils @ 25°C ex. cable	R _{ph}	Ω	6.3	1.6	7.6	1.3	3.8	0.65
Induction per Phase	I < 0.6 I _p	L _{ph}	mH	51	13	60	10	30	5
Electrical Time Constant*	coils @ 25°C	τ _e	ms	8		8		8	
Maximum Continuous Power Loss	all coils	P _c	W	430		530		1060	
Thermal Resistance	coils to mount. sfc.	R _{th}	°C/W	0.15		0.12		0.06	
Thermal Time Constant*	to max. coil temp.	τ _{th}	s	90		90		90	
Temperature Cut-off / Sensor				PTC 1kΩ / KTY83-122					
Coil Unit Weight	ex. cables	W	kg	4.9		5.9		11.6	
Coil Unit Length	ex. cables	L	mm	244		290		562	
Motor Attraction Force	rms @ 0 A	F _a	N	3400		4150		8300	
Magnet Pitch NN		τ	mm	24		24		24	
Cable Mass		m	kg/m	0.3		0.3		0.3	
Cable Type (Power)	length 1 m	d	mm (AWG)	11.9 (14)					
Cable Type (Sensor)	length 1 m	d	mm (AWG)	4.3 (26)					

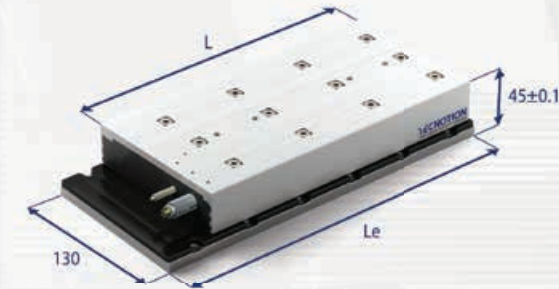

TB12 on 288mm magnet plate shown

Approvals



Magnet plate dimensions

Le (mm)	192	288
M5 bolts	8	12
Mass (kg/m)	10.5	

Magnet plates can be butted together.

All specifications ±10%

* These values are only applicable when the mounting surface is at 20°C and the motor is driven at maximum continuous current. If these values differ in your application, please check our simulation tool.

** Actual values depend on bus voltage. Please check the F/V diagram in our simulation tool.

*** Production date end of 2013.

Mounting instructions and flatness or parallelism requirements can be found in the Iron Core installation manual. CAD files and 3D models can be downloaded from our website.

MAGNET PLATES

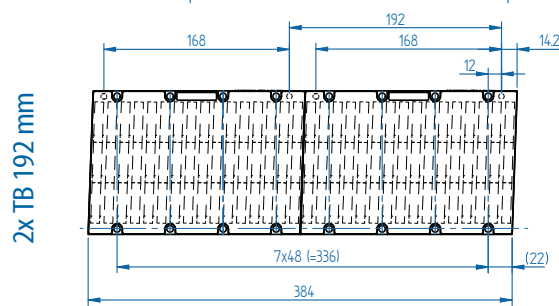
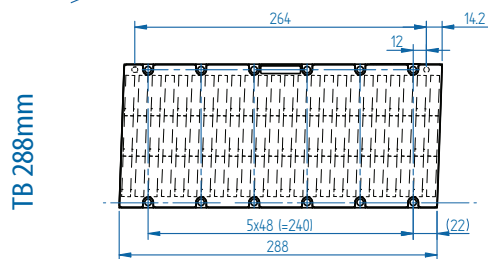
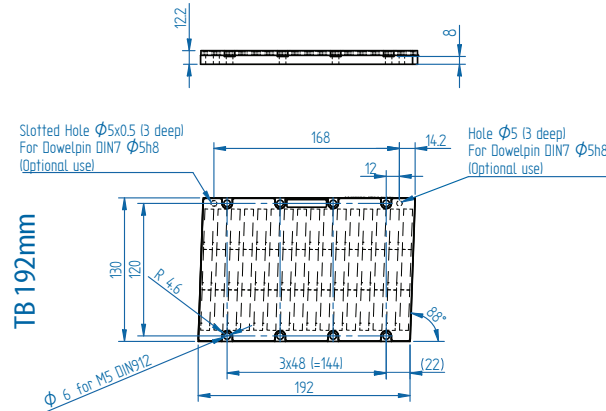
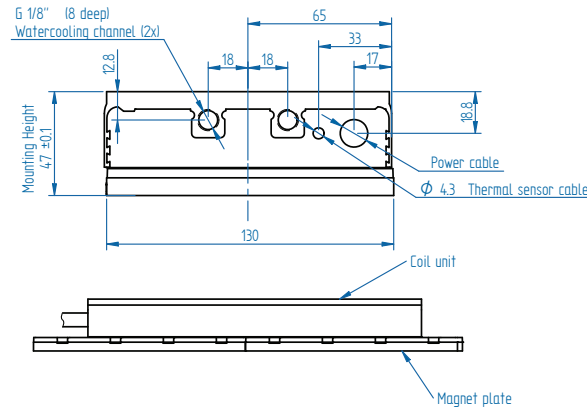

COIL UNITS

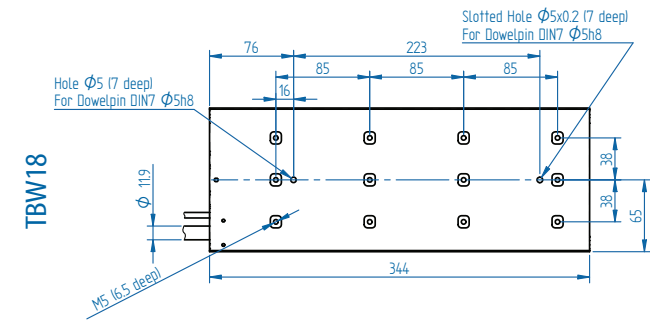
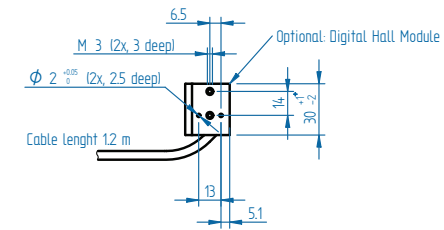

TBW30

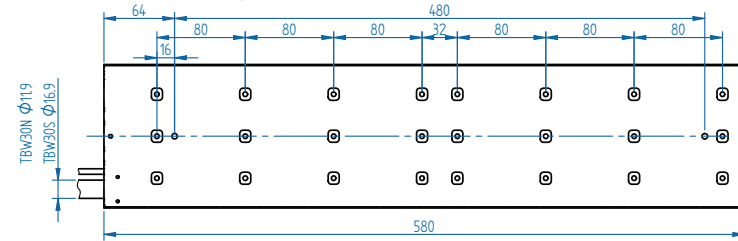

TBW45

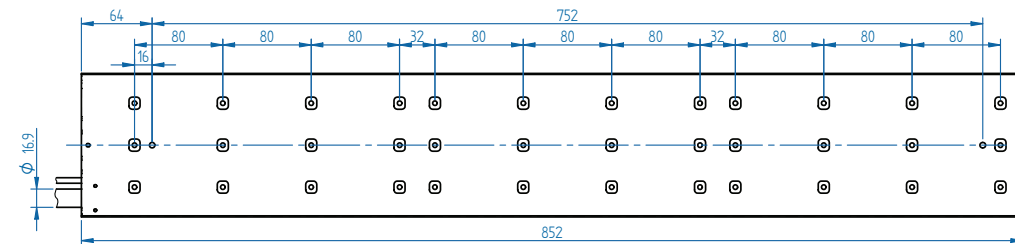

	Parameter	Remarks	Symbol	Unit	TBW18		TBW30		TBW45	
Performance	Winding type				N	S	N	S	N	S
	Motortype, max voltage ph-ph				3-phase synchronous Iron core, 400V _{ac rms} (600V _{dc})					
	Ultimate Force @ 10°C/s increase	magnet @ 25°C	F _u	N	2700		4500		6750	
	Peak Force @ 6°C/s increase	magnet @ 25°C	F _p	N	2400		4000		6000	
	Continuous Force Watercooled*	coils @ 100°C	F _{cw}	N	1200		2000		3000	
	Continuous Force Aircooled*	coils @ 100°C	F _c	N	1140		1900		2850	
	Maximum Speed**	@ 560 V	v _{max}	m/s	3	6	2.5	6	2.5	6
	Motor Force Constant	mount. sfc. @ 20°C	K	N/A _{rms}	186	90	225	93	225	93
	Motor Constant	coils @ 25°C	S	N ² /W	2580		4300		6450	
Electrical	Ultimate Current	magnet @ 25°C	I _u	A _{rms}	19.6	41	27	65	41	98
	Peak Current	magnet @ 25°C	I _p	A _{rms}	15.0	31.1	20.7	50	31	75
	Continuous Current Watercooled*	coils @ 100°C	I _{cw}	A _{rms}	6.5	13.4	8.9	21.5	13.4	32.3
	Back EMF Phase-Phase _{peak}		B _{emf}	V / m/s	152	76	183	76	183	76
	Resistance per Phase*	coils @ 25°C ex. cable	R _{ph}	Ω	4.4	1.0	3.9	0.66	2.6	0.44
	Induction per Phase	I < 0.6 I _p	L _{ph}	mH	35	8	31	5	21	3
	Electrical Time Constant*	coils @ 25°C	τ _e	ms	8		8		8	
Thermal	Maximum Continuous Power Loss	all coils	P _c	W	726		1209		1804	
	Thermal Resistance	coils to mount. sfc.	R _{th}	°C/W	0.10		0.06		0.04	
	Thermal Time Constant*	to max. coil temp.	τ _{th}	s	87		87		87	
	Watercooling Flow	for ΔT=3K	Φ _w	l/min	3.1		5.2		7.8	
	Watercooling Pressure-drop	order of magnitude	ΔP _w	bar	1.0		1.5		2.5	
	Temperature Cut-off / Sensor				PTC 1kΩ / KTY83-122					
Mechanical	Coil Unit Weight	ex. cables	W	kg	7.3		12.3		18.2	
	Coil Unit Length	ex. cables	L	mm	344		580		852	
	Motor Attraction Force	rms @ 0 A	F _a	N	4900		8300		12450	
	Magnet Pitch NN		τ	mm	24		24		24	
	Cable Mass		m	kg/m	0.3		0.3		0.3	
	Cable Type (Power)	length 1 m	d	mm (AWG)	11.9 (14)			16.9 (10)		
	Cable Type (Sensor)	length 1 m	d	mm (AWG)	4.3 (26)					

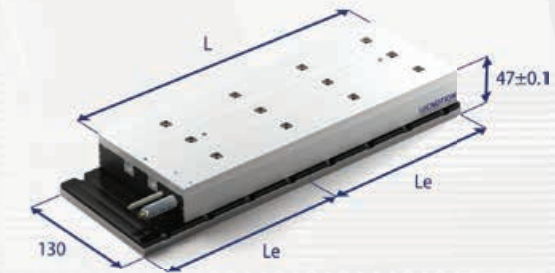

TBW18 on 2x192mm magnet plate shown

Approvals



Water cooling

All TBW motors feature integrated cooling channels that allow for the easy setup of a liquid cooled system, at no additional cost.

Magnet plate dimensions

Le (mm)	192	288
M5 bolts	8	12
Mass (kg/m)	10.5	

Magnet plates can be butted together.

All specifications ±10%

* These values are only applicable when the mounting surface is at 20°C and the motor is driven at maximum continuous current. If these values differ in your application, please check our simulation tool.

** Actual values depend on bus voltage. Please check the F/V diagram in our simulation tool.

***Production date end of 2013.

Toll Free Phone (877) SERV098
 Toll Free Fax (877) SERV099
www.electromate.com
sales@electromate.com

Mounting instructions and flatness or parallelism requirements can be found in the Ironless installation manual. CAD files and 3D models can be downloaded from our website.

MAGNET YOKES

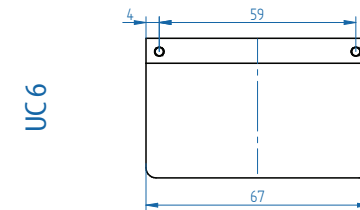
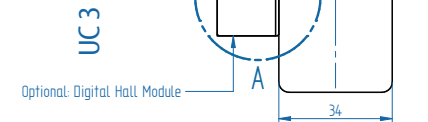
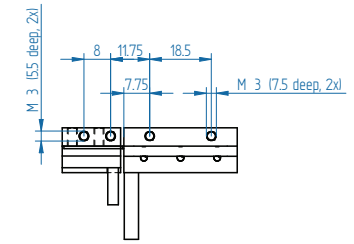
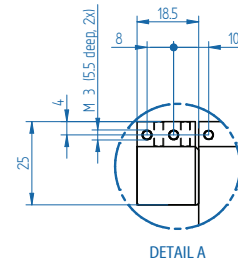
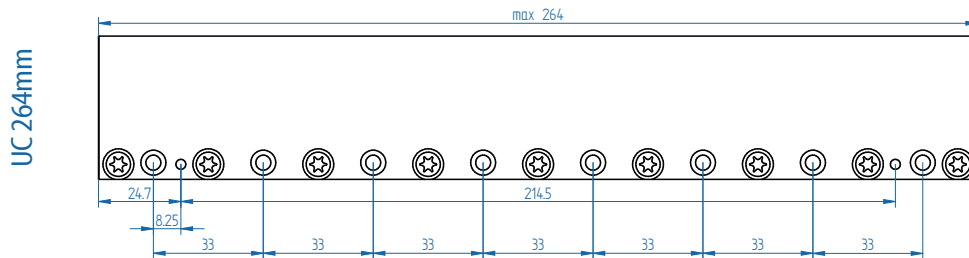
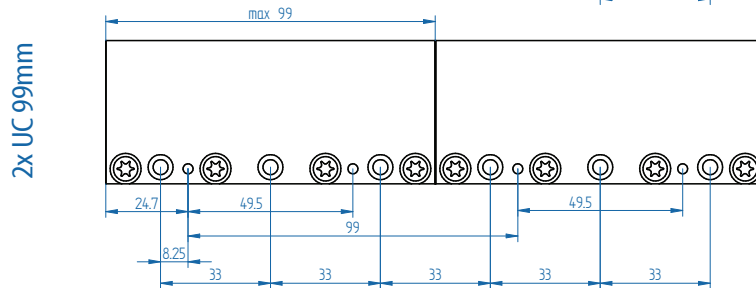
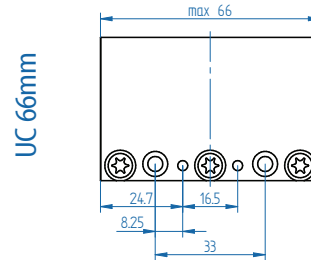
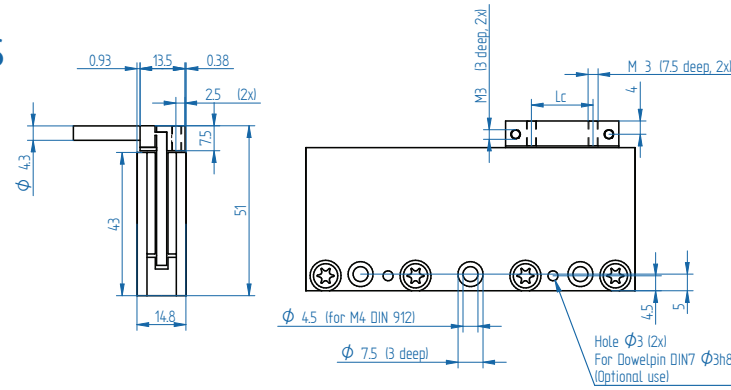

	Dig. Hall cable (mm)	Lc (mm)
UC3	$\phi 3.2$	18.5
UC6	$\phi 3.2$	51.5

	Parameter	Remarks	Symbol	Unit	UC3	UC6
Performance	Motortype, max voltage ph-ph				3-phase synchronous Ironless, 45V _{ac rms} (60V _{dc})	
	Peak Force @ 20°C/s increase	magnet @ 25°C	F _p	N	36	72
	Continuous Force*	coils @ 80°C	F _c	N	10	20
	Maximum Speed**	@ 60 V	v _{max}	m/s	5	5
	Motor Force Constant	mount. sfc. @ 20°C	K	N/A _{rms}	11.4	11.4
	Motor Constant	coils @ 25°C	S	N ² /W	9.2	18.3
Electrical	Peak Current	magnet @ 25°C	I _p	A _{rms}	3.1	6.2
	Maximum Continuous Current	coils @ 80°C	I _c	A _{rms}	0.87	1.75
	Back EMF Phase-Phase _{peak}		B _{emf}	V / m/s	9.3	9.3
	Resistance per Phase*	coils @ 25°C ex. cable	R _{ph}	Ω	4.7	2.4
	Induction per Phase	I < 0.6 I _p	L _{ph}	mH	0.75	0.38
	Electrical Time Constant*	coils @ 25°C	τ _e	ms	0.16	0.16
Thermal	Maximum Continuous Power Loss	all coils	P _c	W	13	26
	Thermal Resistance	coils to mount. sfc.	R _{th}	°C/W	3.6	1.8
	Thermal Time Constant*	to max. coil temp.	τ _{th}	s	25	25
	Temperature Sensors				none	none
Mechanical	Coil Unit Weight	ex. cables	W	kg	0.031	0.062
	Coil Unit Length	ex. cables	L	mm	34	67
	Motor Attraction Force		F _a	N	0	0
	Magnet Pitch NN		τ	mm	16.5	16.5
	Cable Mass		m	kg/m	0.07	0.07
	Cable Type (Power)	length 1 m	d	mm (AWG)	4.3 (24)	
	Cable Type (Sensor)				N/A	
	Cable Life (Power FLEX)***	minimum			15,000,000 cycles	
	Bending Radius Static	minimum			5x cable diameter	
	Bending Radius Dynamic	minimum			8x cable diameter	

* These values are only applicable when the mounting surface is at 20°C and the motor is driven at maximum continuous current. If these values differ in your application, please check our simulation tool.
 ** Actual values depend on bus voltage. Please check the F/V diagram in our simulation tool.
 *** Depending on Bending Radius, Velocity and Acceleration.

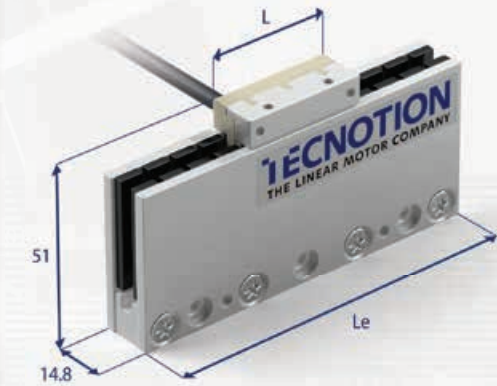

UC3 in 99mm magnet yoke shown

Approvals



Magnet yoke dimensions

Le (mm)	66	99	264
M4 bolts	2	3	8
Mass (kg/m)	3.2		

Magnet yokes can be butted together.

All specifications ±10%

Mounting instructions and flatness or parallelism requirements can be found in the Ironless installation manual. CAD files and 3D models can be downloaded from our website.

MAGNET YOKES

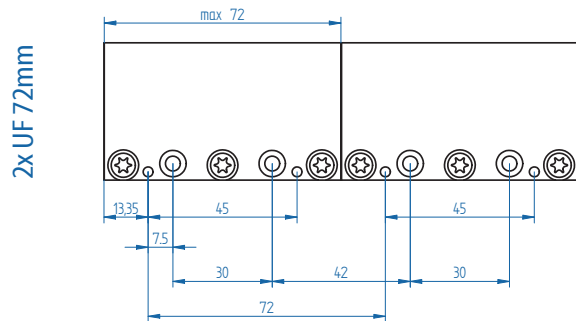
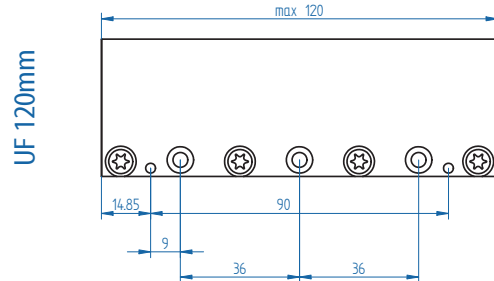
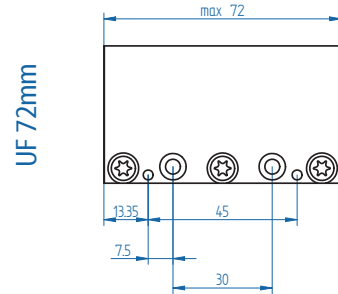
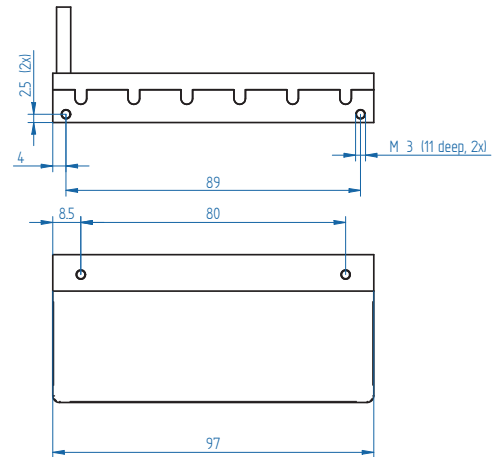
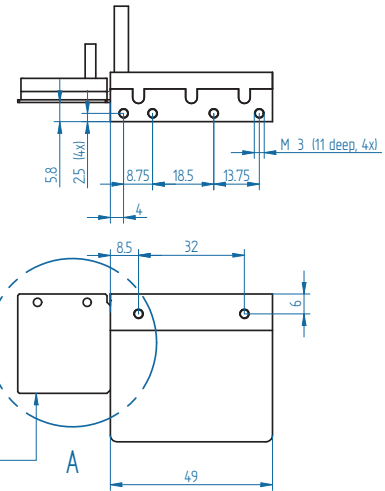
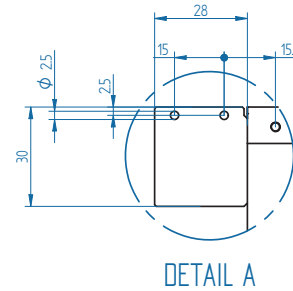
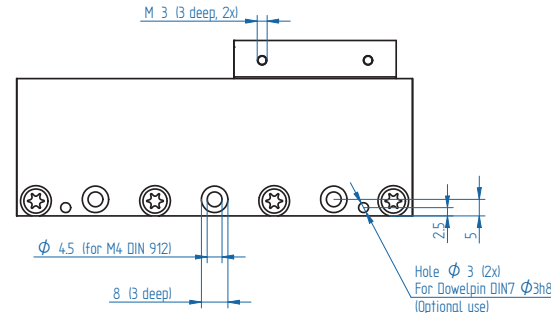
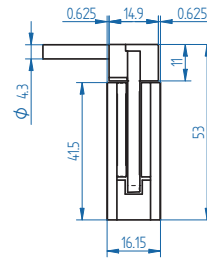

	Parameter	Remarks	Symbol	Unit	UF3	UF6
Performance	Motortype, max voltage ph-ph				3-phase synchronous Ironless, 45V _{ac rms} (60V _{dc})	
	Peak Force @ 20°C/s increase	magnet @ 25°C	F _p	N	42.5	85
	Continuous Force*	coils @ 110°C	F _c	N	19.5	39
	Maximum Speed**	@ 60 V	v _{max}	m/s	5.1	5.1
	Motor Force Constant	mount. sfc. @ 20°C	K	N/A _{rms}	12.3	12.3
	Motor Constant	coils @ 25°C	S	N ² /W	14.6	29.2
Electrical	Peak Current	magnet @ 25°C	I _p	A _{rms}	3.5	6.9
	Maximum Continuous Current	coils @ 110°C	I _c	A _{rms}	1.58	3.17
	Back EMF Phase-Phase _{peak}		B _{emf}	V / m/s	10.1	10.1
	Resistance per Phase*	coils @ 25°C ex. cable	R _{ph}	Ω	3.5	1.8
	Induction per Phase	l < 0.6 Ip	L _{ph}	mH	1.24	0.62
	Electrical Time Constant*	coils @ 25°C	τ _e	ms	0.36	0.36
Thermal	Maximum Continuous Power Loss	all coils	P _c	W	35	70
	Thermal Resistance	coils to mount. sfc.	R _{th}	°C/W	2.4	1.2
	Thermal Time Constant	to max. coil temp.	τ _{th}	s	34	34
	Temperature Sensor*				NTC	NTC
Mechanical	Coil Unit Weight	ex. cables	W	kg	0.045	0.087
	Coil Unit Length	ex. cables	L	mm	49	97
	Motor Attraction Force		F _a	N	0	0
	Magnet Pitch NN		τ	mm	24	24
	Cable Mass		m	kg/m	0.07	0.07
	Cable Type (Power and Sensor)	length 1 m	d	mm (AWG)	4.3 (24)	
	Cable Life (FLEX)***	minimum			15,000,000 cycles	
	Bending Radius Static	minimum			5x cable diameter	
	Bending Radius Dynamic	minimum			8x cable diameter	

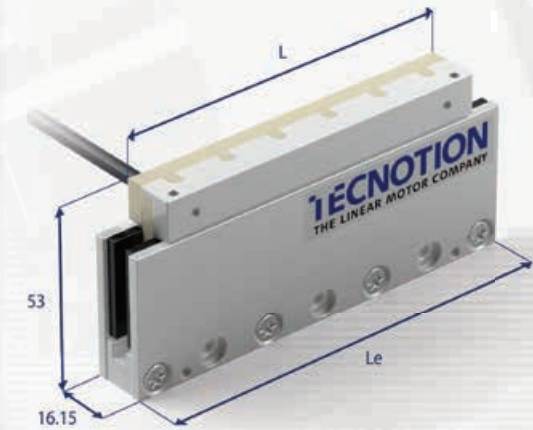

UF6 in 120mm magnet yoke shown

Approvals



Magnet yoke dimensions

Le (mm)	72	120
M4 bolts	2	3
Mass (kg/m)	3.2	
Magnet yokes can be butted together.		

All specifications ±10%

* These values are only applicable when the mounting surface is at 20°C and the motor is driven at maximum continuous current. If these values differ in your application, please check our simulation tool.

** Actual values depend on bus voltage. Please check the F/V diagram in our simulation tool.

*** Depending on radius, velocity and acceleration.

Mounting instructions and flatness or parallelism requirements can be found in the Ironless installation manual. CAD files and 3D models can be downloaded from our website.

MAGNET YOKES

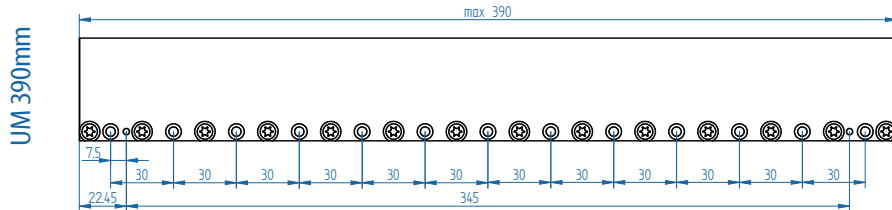
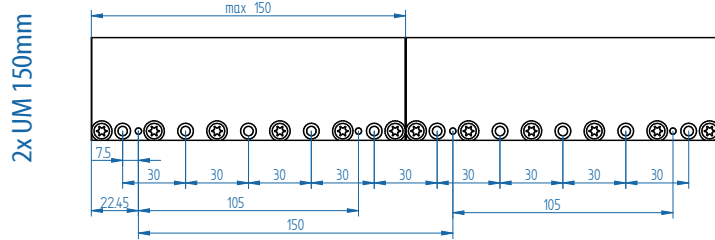
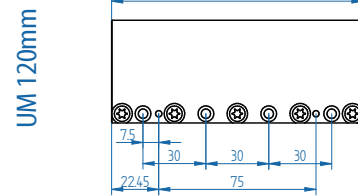
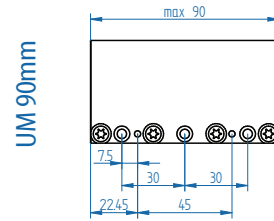
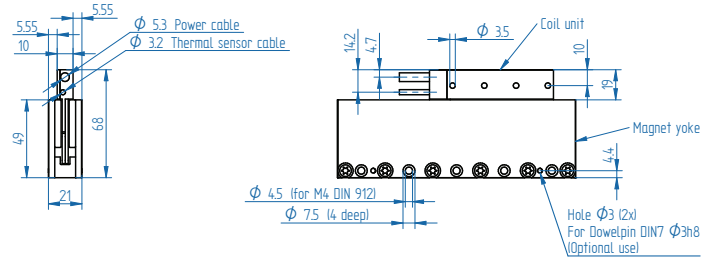

COIL UNITS

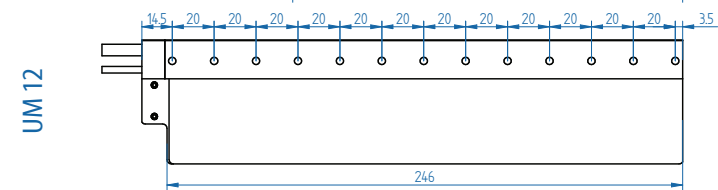
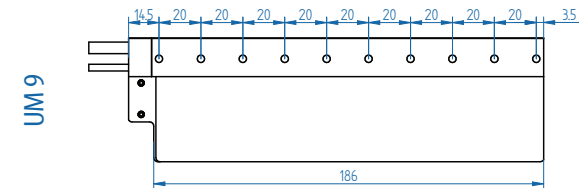
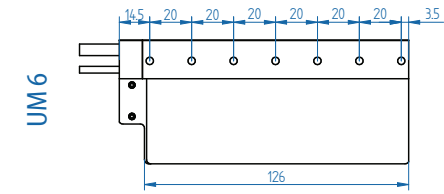
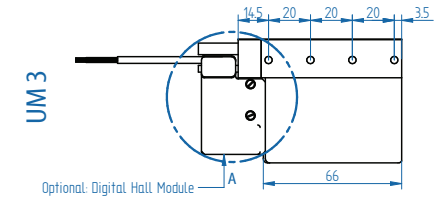
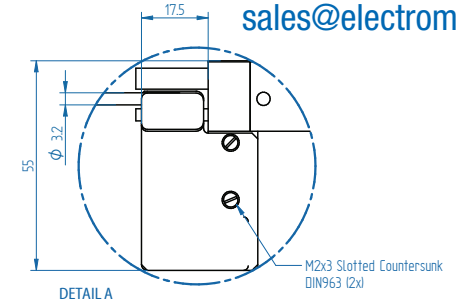

Parameter	Remarks	Symbol	Unit	UM3		UM6		UM9		UM12	
Winding type				N	S	N	S	N	S	N	S
Motor type, max voltage ph-ph				3-phase synchronous Ironless, 230V _{ac rms} (300V _{dc})							
Peak Force @ 20°C/s increase	magnet @ 25°C	F _p	N	100		200		300		400	
Continuous Force*	coils @ 110°C	F _c	N	29		58		87		116	
Maximum Speed**	@ 300 V	v _{max}	m/s	10	18	10	18	10	17	10	16
Motor Force Constant	mount. sfc. @ 20°C	K	N/A _{rms}	36.3	19.9	36.3	19.9	36.3	19.9	36.3	19.9
Motor Constant	coils @ 25°C	S	N ² /W	24		48		71		95	
Peak Current	magnet @ 25°C	I _p	A _{rms}	2.8	5.0	5.5	10.0	8.3	15.0	11.0	20.0
Maximum Continuous Current	coils @ 110°C	I _c	A _{rms}	0.8	1.5	1.6	2.9	2.4	4.4	3.2	5.8
Back EMF Phase-Phase _{peak}		B _{emf}	V / m/s	30	16	30	16	30	16	30	16
Resistance per Phase*	coils @ 25°C ex. cable	R _{ph}	Ω	18.5	5.5	9.3	2.8	6.2	1.8	4.6	1.4
Induction per Phase	I < 0.6 I _p	L _{ph}	mH	6	1.8	3	0.9	2	0.6	1.5	0.4
Electrical Time Constant*	coils @ 25°C	τ _e	ms	0.35		0.35		0.35		0.35	
Maximum Continuous Power Loss	all coils	P _c	W	47		95		142		190	
Thermal Resistance	coils to mount. sfc.	R _{th}	°C/W	1.8		0.9		0.6		0.45	
Thermal Time Constant*	to max. coil temp.	τ _{th}	s	36		36		36		36	
Temperature Cut-off / Sensor				PTC 1kΩ / NTC							
Coil Unit Weight	ex. cables	W	kg	0.084		0.162		0.240		0.318	
Coil Unit Length	ex. cables	L	mm	78		138		198		258	
Motor Attraction Force		F _a	N	0		0		0		0	
Magnet Pitch NN		τ	mm	30		30		30		30	
Cable Mass		m	kg/m	0.08		0.08		0.08		0.08	
Cable Type (Power)	length 1 m	d	mm (AWG)	5.3 (22)							
Cable Type (Sensor)	length 1 m	d	mm (AWG)	3.2 (26)							

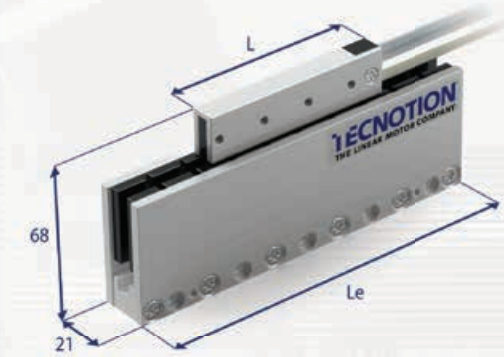

UM3 in 150mm magnet yoke shown

Approvals



Magnet yoke dimensions

Le (mm)	90	120	150	390
M4 bolts	3	4	6	13
Mass (kg/m)	4.8			

Magnet yokes can be butted together.

All specifications ±10%

* These values are only applicable when the mounting surface is at 20°C and the motor is driven at maximum continuous current. If these values differ in your application, please check our simulation tool.

** Actual values depend on bus voltage. Please check the F/V diagram in our simulation tool.

	Parameter	Remarks	Symbol	Unit	UL3		UL6		UL9		UL12		UL15			
					N	S	N	S	N	S	N	S	N	S		
Performance	Winding type				N	S	N	S	N	S	N	S	N	S		
	Motor type, max voltage ph-ph				3-phase synchronous Ironless, 230V _{ac rms} (300V _{dc})											
	Peak Force @ 20°C/s increase	magnet @ 25°C	F _p	N	240		480		720		960		1200			
	Continuous Force*	coils @ 110°C	F _c	N	70		140		210		280		350			
	Maximum Speed**	@ 300 V	v _{max}	m/s	5	12	5	12	5	12	5	12	5	12		
	Motor Force Constant	mount. sfc. @ 20°C	K	N/A _{rms}	68	27.5	68	27.5	68	27.5	68	27.5	67.5	27.5		
	Motor Constant	coils @ 25°C	S	N ² /W	97		195		290		390		485			
Electrical	Peak Current	magnet @ 25°C	I _p	A _{rms}	3.5	8.7	7	17.5	10.5	26.2	14.1	35	17.8	44		
	Maximum Continuous Current	coils @ 110°C	I _c	A _{rms}	1.03	2.6	2.1	5.1	3.1	7.6	4.2	10.2	5.2	12.9		
	Back EMF Phase-Phase _{peak}		B _{emf}	V / m/s	55.5	22.5	55.5	22.5	55.5	22.5	55.5	22.5	55.5	22.5		
	Resistance per Phase*	coils @ 25°C ex. cable	R _{ph}	Ω	15.9	2.6	8.0	1.28	5.3	0.85	4.0	0.64	3.3	0.53		
	Induction per Phase	I < 0.6 I _p	L _{ph}	mH	13	2.0	6.5	1.0	4.2	0.7	3.2	0.5	3	0.4		
	Electrical Time Constant*	coils @ 25°C	τ _e	ms	0.8		0.8		0.8		0.8		0.8			
Thermal	Maximum Continuous Power Loss	all coils	P _c	W	67		134		200		270		335			
	Thermal Resistance	coils to mount. sfc.	R _{th}	°C/W	1.3		0.65		0.43		0.32		0.26			
	Thermal Time Constant*	to max. coil temp.	τ _{th}	s	72		72		72		72		72			
	Temperature Cut-off / Sensor				PTC 1kΩ / NTC											
Mechanical	Coil Unit Weight	ex. cables	W	kg	0.250		0.470		0.690		0.910		1.130			
	Coil Unit Length	ex. cables	L	mm	106		190		274		358		442			
	Motor Attraction Force		F _a	N	0		0		0		0		0			
	Magnet Pitch NN		τ	mm	42		42		42		42		42			
	Cable Mass		m	kg/m	0.09		0.09		0.09		0.105		0.105			
	Cable Type (Power)	length 1 m	d	mm (AWG)					5.8 (20)				6.4 (18)			
	Cable Type (Sensor)	length 1 m	d	mm (AWG)					4.3 (26)				4.3 (26)			

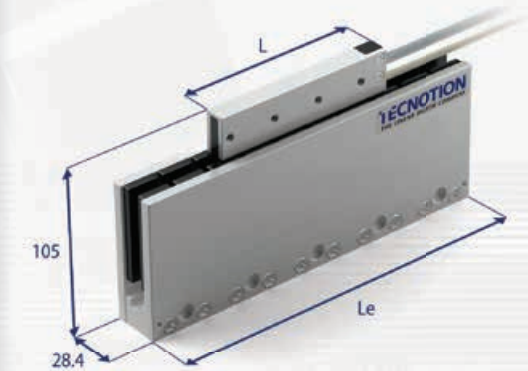

UL3 in 210mm magnet yoke shown

Approvals



Magnet yoke dimensions

Le (mm)	126	168	210	546
M5 bolts	3	4	5	13
Mass (kg/m)	11.2			

Magnet yokes can be butted together.

All specifications ±10%

* These values are only applicable when the mounting surface is at 20°C and the motor is driven at maximum continuous current. If these values differ in your application, please check our simulation tool.

** Actual values depend on bus voltage. Please check the F/V diagram in our simulation tool.

Mounting instructions and flatness or parallelism requirements can be found in the Ironless installation manual. CAD files and 3D models can be downloaded from our website.

MAGNET YOKES

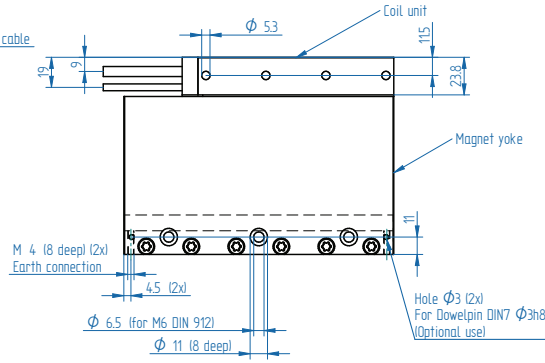
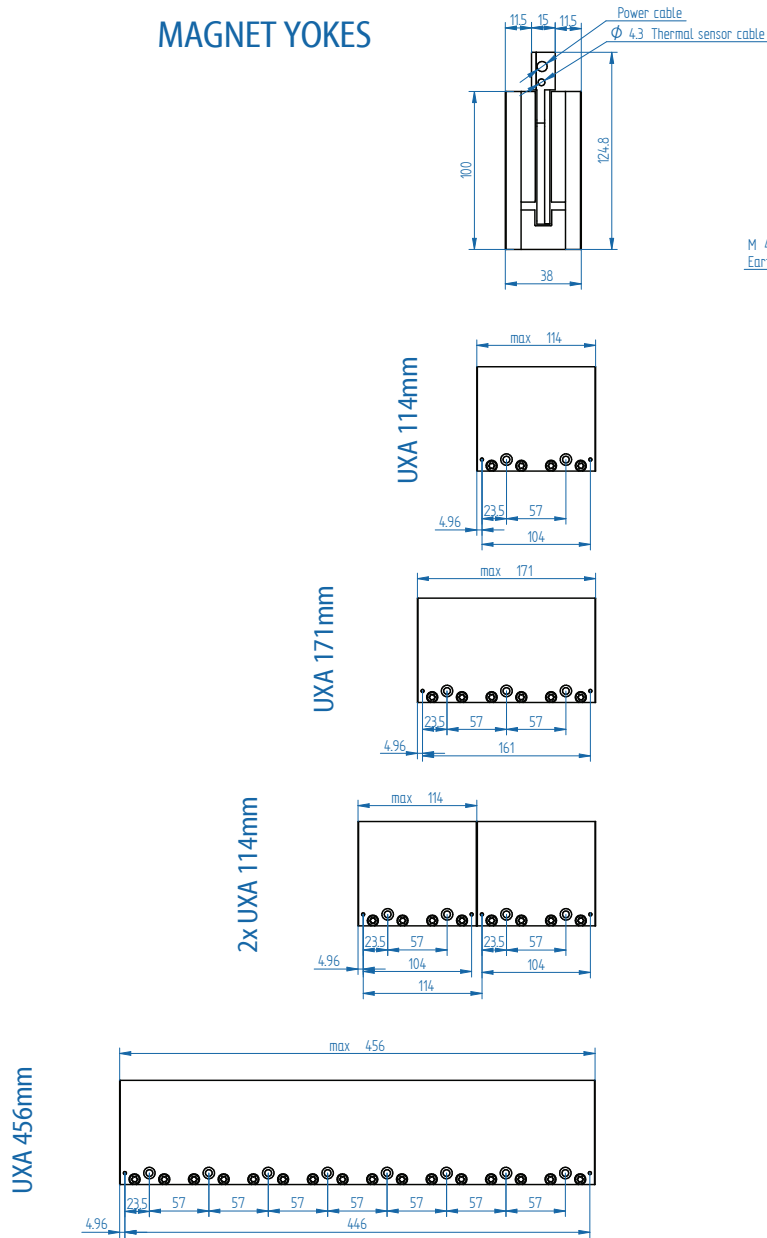

COIL UNITS

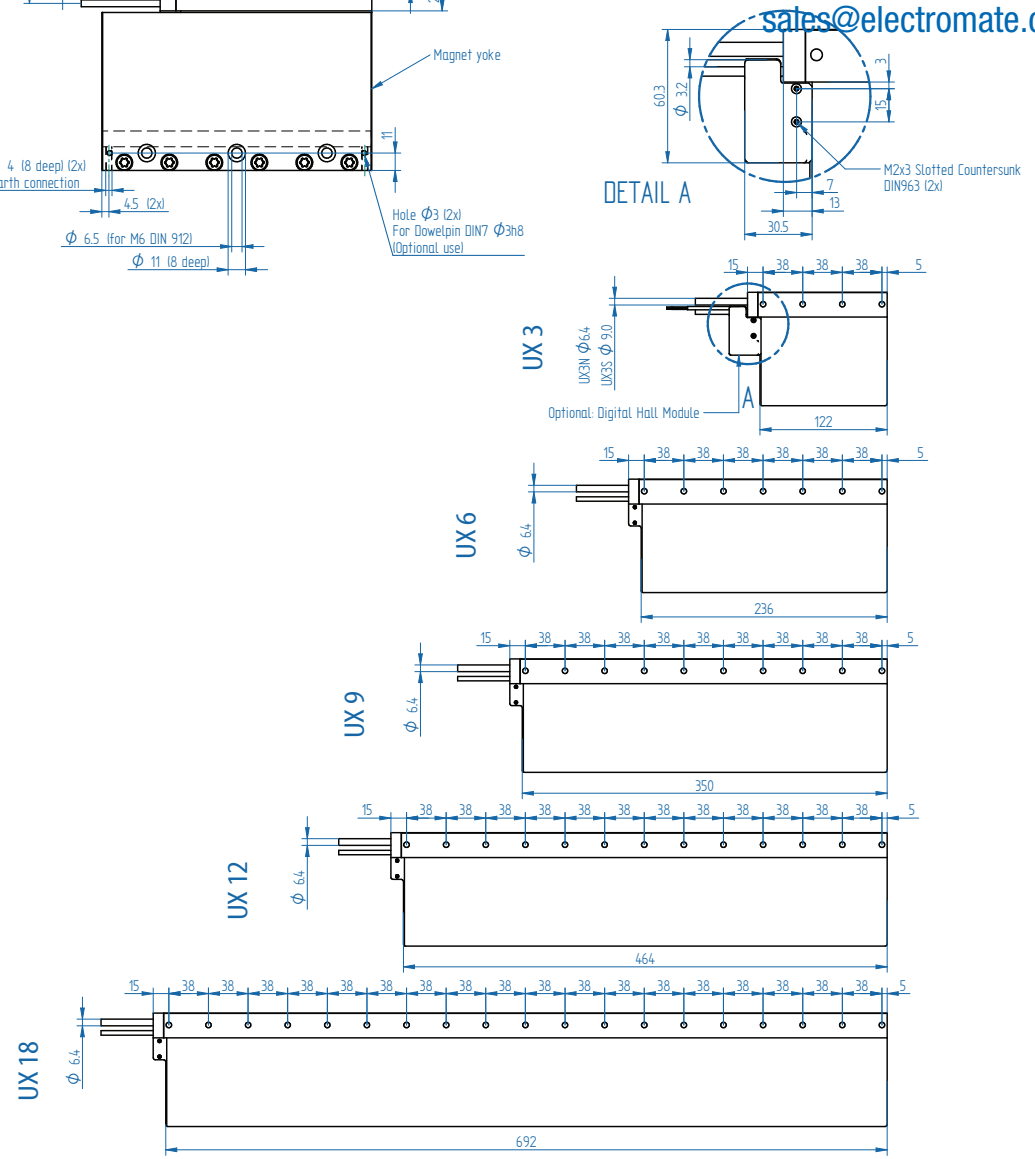

	Parameter	Remarks	Symbol	Unit	UXA3		UXA6		UXA9		UXA12		UXA18
					N	S	N	S	N	S	N	S	N
Performance	Winding type				N	S	N	S	N	S	N	S	N
	Motor type, max voltage ph-ph				3-phase synchronous Ironless, 230V _{ac rms} (300V _{dc})								
	Peak Force @ 20°C/s increase	magnet @ 25°C	F _p	N	615		1230		1845		2460		3690
	Continuous Force*	coils @ 110°C	F _c	N	120		240		360		480		720
	Maximum Speed**	@ 300 V	v _{max}	m/s	2.9	7.2	2.9	7.2	2.9	7.2	2.9	7.2	2.9
	Motor Force Constant	mount. sfc. @ 20°C	K	N/A _{rms}	107	43.4	107	43.4	107	43.4	107	43.4	107
	Motor Constant	coils @ 25°C	S	N ² /W	244		488		732		976		1464
Electrical	Peak Current	magnet @ 25°C	I _p	A _{rms}	5.6	13.9	11.3	28	16.9	42	22.6	56	34
	Maximum Continuous Current	coils @ 110°C	I _c	A _{rms}	1.14	2.80	2.27	5.6	3.4	8.4	4.5	11.2	6.8
	Back EMF Phase-Phase Peak		B _{emf}	V / m/s	87	35	87	35	87	35	87	35	87
	Resistance per Phase*	coils @ 25°C ex. cable	R _{ph}	Ω	15.8	2.6	7.9	1.29	5.3	0.86	4.0	0.65	2.6
	Induction per Phase	l < 0.6 Ip	L _{ph}	mH	28	4.6	14	2.3	9	1.5	7	1.2	4.7
	Electrical Time Constant*	coils @ 25°C	τ _e	ms	1.8		1.8		1.8		1.8		1.8
Thermal	Maximum Continuous Power Loss	all coils	P _c	W	82		165		247		330		494
	Thermal Resistance	coils to mount. sfc.	R _{th}	°C/W	1.04		0.52		0.35		0.26		0.17
	Thermal Time Constant	to max. coil temp.	τ _{th}	s	156		156		156		156		156
	Temperature Cut-off / Sensor*				PTC 1kΩ / NTC								
Mechanical	Coil Unit Weight	ex. cables	W	kg	0.55		0.95		1.35		1.75		2.55
	Coil Unit Length	ex. cables	L	mm	134		248		362		476		704
	Motor Attraction Force		F _a	N	0		0		0		0		0
	Magnet Pitch NN		τ	mm	57		57		57		57		57
	Cable Mass		m	kg/m	0.18		0.18		0.18		0.18		0.18
	Cable Type (Power)	length 1 m	d	mm (AWG)	6.4 (18) except UXA3S***								
	Cable Type (Sensor)	length 1 m	d	mm (AWG)	4.3 (26)								

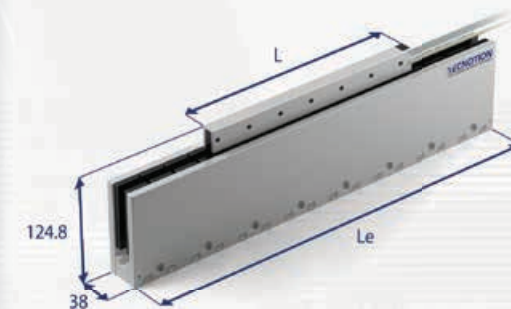

UXA6 in 456mm magnet yoke shown

Approvals



UXA3S Power Cable (FLEX)	
Cable Type	9.0 (21) mm (AWG)
Cable Life****	5,000,000 cycles
Bending Radius Static	4x cable diameter
Bending Radius Dynamic	10x cable diameter

**** Depending on Bending Radius, Velocity and Acceleration.

Magnet yoke dimensions			
Le (mm)	114	171	456
M6 bolts	2	3	8
Mass (kg/m)	19		
Magnet yokes can be butted together.			

All specifications ±10%

* These values are only applicable when the mounting surface is at 20°C and the motor is driven at maximum continuous current. If these values differ in your application, please check our simulation tool.

** Actual values depend on bus voltage. Please check the F/V diagram in our simulation tool.

*** The UXA3S is only available with a FLEX power cable. The specifications for this cable can be found in the table on the right side of this page.

Mounting instructions and flatness or parallelism requirements can be found in the Ironless installation manual. CAD files and 3D models can be downloaded from our website.

MAGNET YOKES

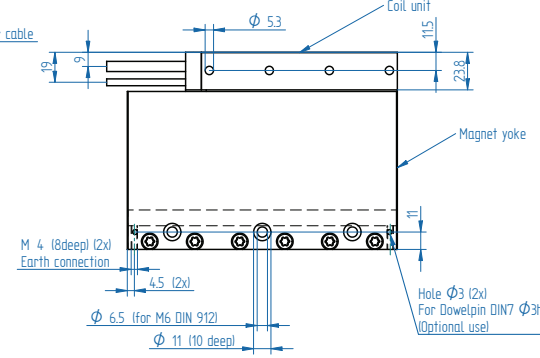
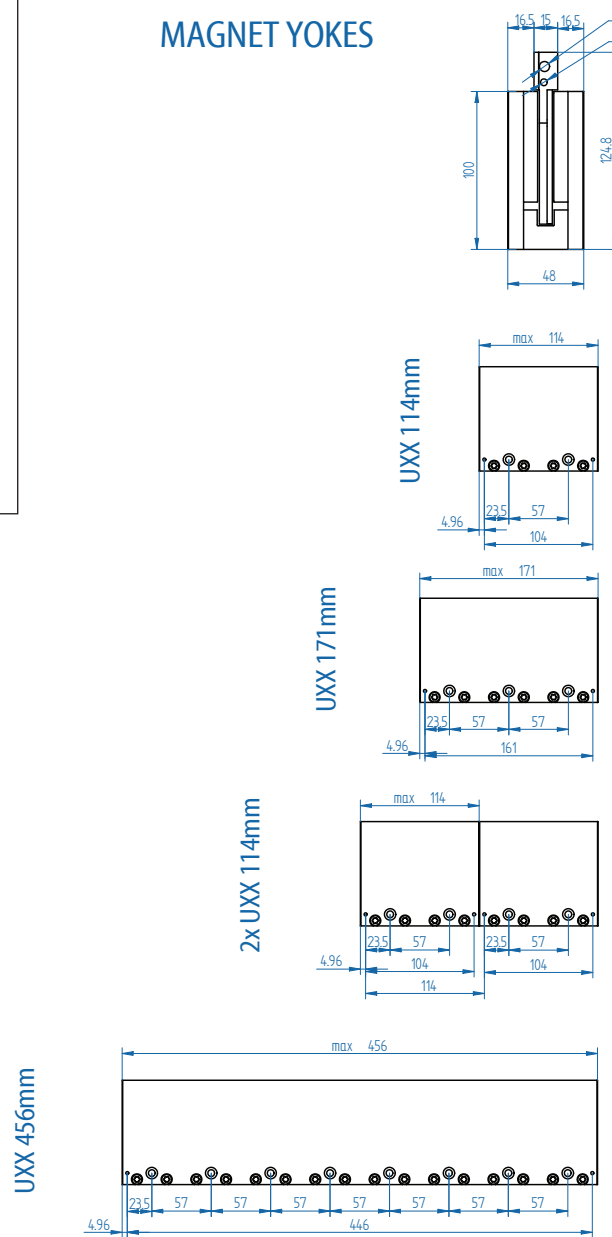

COIL UNITS

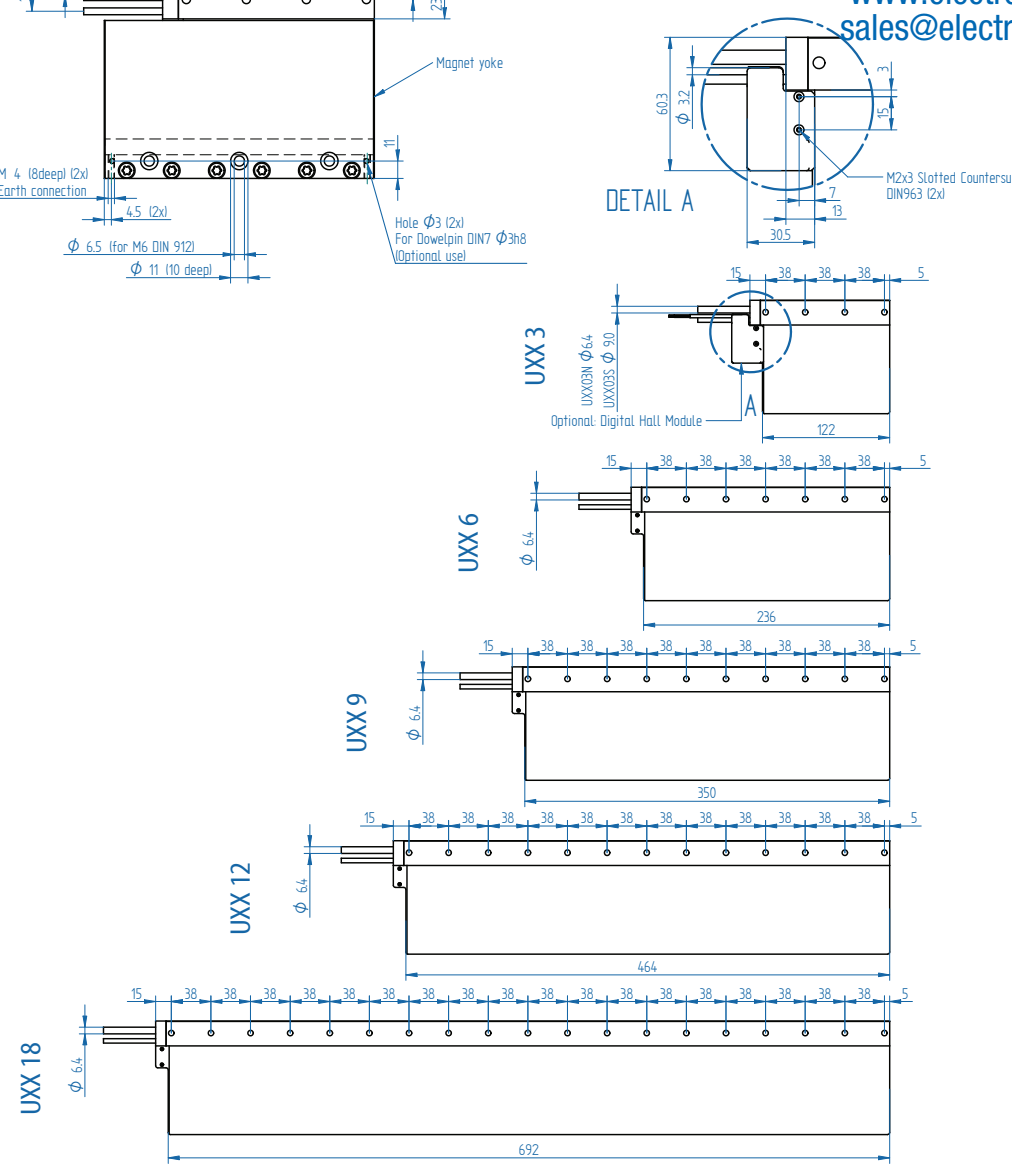

	Parameter	Remarks	Symbol	Unit	UXX3		UXX6		UXX9		UXX12		UXX18
					N	S	N	S	N	S	N	S	N
Performance	Winding type				N	S	N	S	N	S	N	S	N
	Motor type, max voltage ph-ph				3-phase synchronous Ironless, 230V _{ac rms} (300V _{dc})								
	Peak Force @ 20°C/s increase	magnet @ 25°C	F _p	N	700		1400		2100		2800		4200
	Continuous Force*	coils @ 110°C	F _c	N	141		282		423		564		846
	Maximum Speed**	@ 300 V	v _{max}	m/s	2.7	6.6	2.7	6.6	2.7	6.6	2.7	6.6	2.7
	Motor Force Constant	mount. sfc. @ 20°C	K	N/A _{rms}	124	50.3	124	50.3	124	50.3	124	50.3	124
Electrical	Motor Constant	coils @ 25°C	S	N ² /W	323		647		970		1293		1940
	Peak Current	magnet @ 25°C	I _p	A _{rms}	5.6	13.9	11.3	28	16.9	42	22.6	56	34
	Maximum Continuous Current	coils @ 110°C	I _c	A _{rms}	1.14	2.80	2.27	5.6	3.4	8.4	4.5	11.2	6.8
	Back EMF Phase-Phase _{peak}		B _{emf}	V / m/s	101	41	101	41	101	41	101	41	101
	Resistance per Phase*	coils @ 25°C ex. cable	R _{ph}	Ω	15.8	2.6	7.9	1.29	5.3	0.86	4.0	0.65	2.6
	Induction per Phase	l < 0.6 Ip	L _{ph}	mH	28	4.6	14	2.3	9	1.5	7	1.2	4.7
Thermal	Electrical Time Constant*	coils @ 25°C	τ _e	ms	1.8		1.8		1.8		1.8		1.8
	Maximum Continuous Power Loss	all coils	P _c	W	82		165		247		330		494
	Thermal Resistance	coils to mount. sfc.	R _{th}	°C/W	1.04		0.52		0.35		0.26		0.17
	Thermal Time Constant*	to max. coil temp.	τ _{th}	s	156		156		156		156		156
	Temperature Cut-off / Sensor				PTC 1kΩ / NTC								
Mechanical	Coil Unit Weight	ex. cables	W	kg	0.55		0.95		1.35		1.75		2.55
	Coil Unit Length	ex. cables	L	mm	134		248		362		476		704
	Motor Attraction Force		F _a	N	0		0		0		0		0
	Magnet Pitch NN		τ	mm	57		57		57		57		57
	Cable Mass		m	kg/m	0.18		0.18		0.18		0.18		0.18
	Cable Type (Power)	length 1 m	d	mm (AWG)	6.4 (18) except UXX3S***								
	Cable Type (Sensor)	length 1 m	d	mm (AWG)	4.3 (26)								

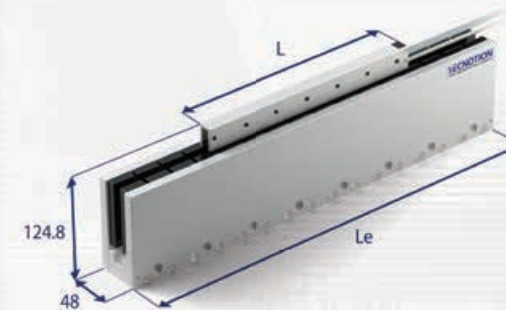

UXX6 in 456mm magnet yoke shown

Approvals



UXX3S Power Cable (FLEX)	
Cable Type	9.0 (21) mm (AWG)
Cable Life****	5,000,000 cycles
Bending Radius Static	4x cable diameter
Bending Radius Dynamic	10x cable diameter

****Depending on Bending Radius, Velocity and Acceleration.

Magnet yoke dimensions			
Le (mm)	114	171	456
M6 bolts	2	3	8
Mass (kg/m)	24		
Magnet yokes can be butted together.			

All specifications ±10%

* These values are only applicable when the mounting surface is at 20°C and the motor is driven at maximum continuous current. If these values differ in your application, please check our simulation tool.

** Actual values depend on bus voltage. Please check the F/V diagram in our simulation tool.

*** The UXX3S is only available with a FLEX power cable. The specifications for this cable can be found in the table on the right side of this page.

Absolute accuracy	100 μ m
Repeatable accuracy	~30 μ m
Resolution	5-10 μ m
Output	1 Vpp SinCos signal
Signal Period	24 mm

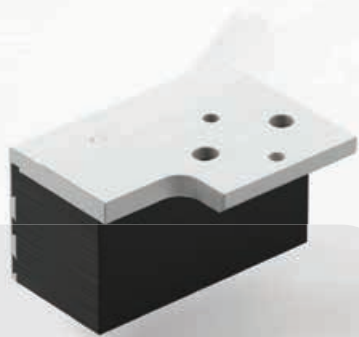

Analog Hall Module

Cost efficient positioning

Linear motors can be positioned extremely accurately by using optical encoders and rulers. If this is not required this expensive setup can be replaced by an analog Hall module. This module uses the magnet track, as opposed to the ruler, as the linear scale. It can be easily mounted on our iron core motors and communicates with practically all standard servo controllers. The analog Hall module requires a standard 5V_{dc} power supply.



Digital Hall Module

For commutation

For commutation, we have an optional digital hall module that can be used with our entire range of linear motors. Its sensors provide 3 digital outputs, each phase shifted 120 degrees, to determine the electrical angle between coils and magnets. If you do not use a controller that allows you to commutate within the servo drive, this module can be a cost-effective alternative. The digital hall module requires a 4.5 to 28V_{dc} power supply.

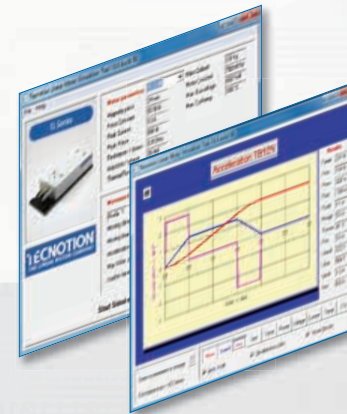

Simulation Tool

Analyze your application

Save precious time by using our FREE linear motor simulation tool. Our specialized software helps you find the best motor for the application and generate reports within seconds, without having to make time consuming calculations by hand. The tool will provide you with diagrams for position, velocity, acceleration, jerk, force, power, voltage, current, temperature, force vs. velocity and more.



Custom Linear Motors

Motor solutions

Besides the standard catalogue items we offer custom linear motor solutions. Some examples: Customized catalogue motors (High performance yokes /custom windings/cable confection) Vacuum motors for transport and positioning in vacuum, rated outgassing up to 10⁻⁷ mbar. As well as Standard Moving magnet motors and Linear actuators, completely designed toward needs. For more information please contact Tecnotion.