

VRSF-SERIES

The intelligent selection for a higher performance planetary gearbox at an ultimate value for standard duty motion control applications. The VRSF utilizes a lightweight aluminum frame, helical cut gear, and bearing span that provides the best level of precision and torque carrying capacity in its competitive class. The noise level generated by the VRSF is greatly reduced in comparison to any other competitor's economy class series that relies on spur gearing. The VRSF can be selected with one of three backlash levels – Standard backlash at 15 arc/min, Reduced backlash at 5 arc/min, and Precision backlash at 3 arc/min.

The series is available in four frame sizes (B, C, D, E) which has a peak output torque of 91 Nm across a variety of ratios. The VRSF is the ideal choice for OEMs manufacturing in larger volume and where accuracy is important and duty cycle is not overly extreme. The VRSF has been very popular in applications such as mobile robotics, standard packaging machinery, medical equipment, and other types of enclosed food processing applications.

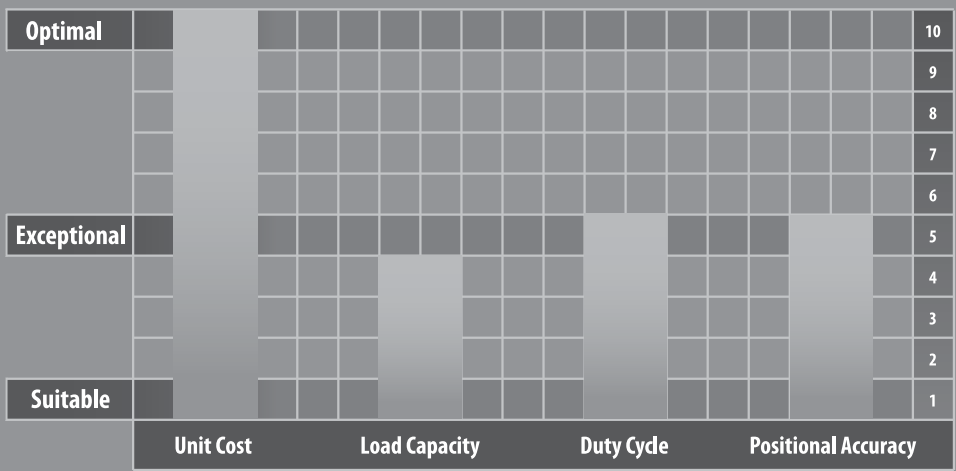



VRSF-SERIES

- Quiet operation: Helical cut gears contribute to reduced vibration and noise
- Different precision levels available in order to choose the best fit and value
- High rigidity & torque: Rigidity and torque capacity are achieved by using uncaged needle roller bearings
- Adapter bushing connection: Enables a simple, effective attachment to most servo motors
- Extremely light weight aluminum body to reduce excess weight from your equipment
- Additional features include NEMA output flange options

Sold & Serviced By:

 **ELECTROMATE**

Toll Free Phone (877) SERV098

Toll Free Fax (877) SERV099

www.electromate.com

sales@electromate.com

VRSF-SERIES Inline shaft

VRSF-Series- Features

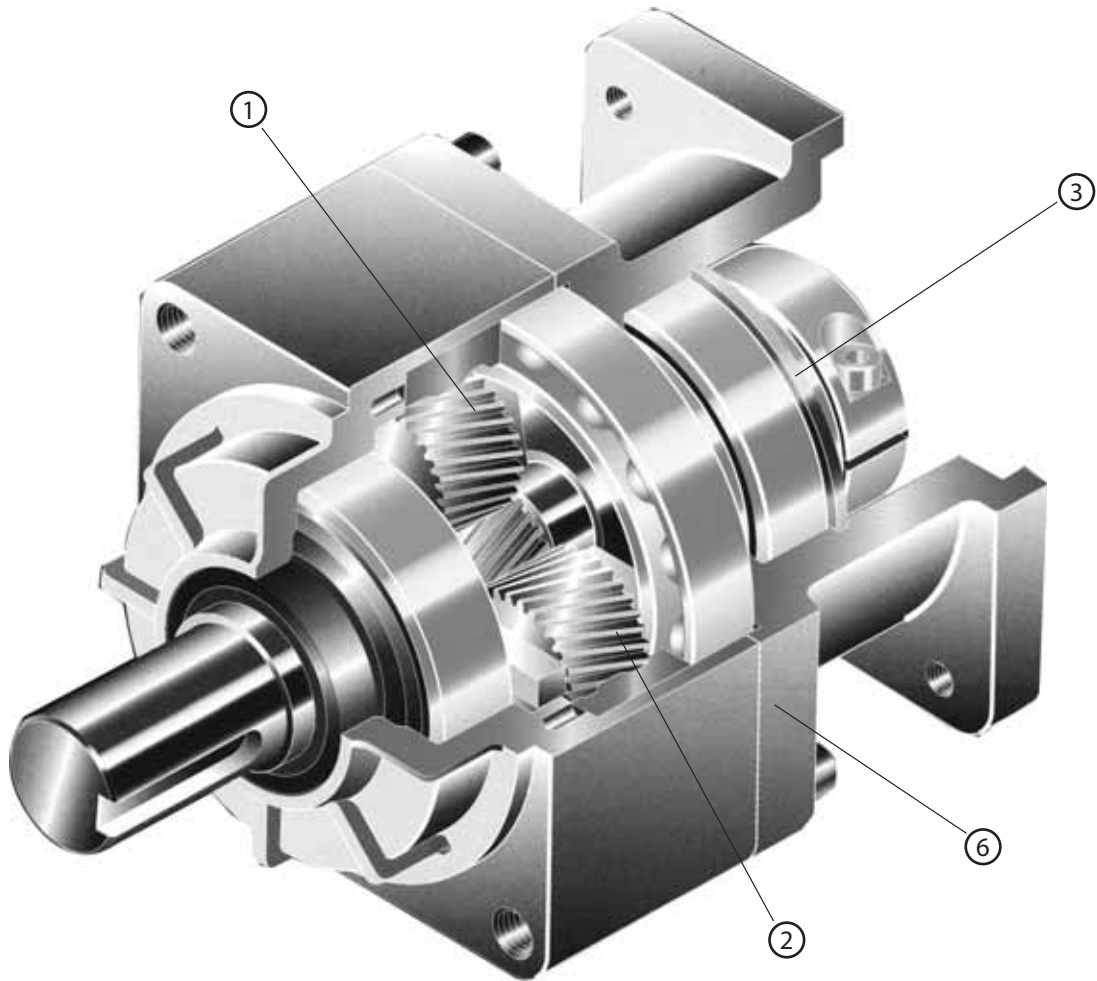

- ① High-precision with backlash 0.05° (three arc-minutes), Low-backlash 0.08° (five arc-minutes) or less certified
- ② Smooth rotation and less pulsation due to utilizing helical gearing
- ③ Maintenance free with long-life grease, the sealed structure allows for mounting in any orientation
- ④ Every possible countermeasure against oil leakage taken: Including impregnation of the case and air leak test
- ⑤ IP65 rating extremely popular in washdown and food grade environments
- ⑥ Various optional features allowed, such as different coatings, plating, and grease varieties

VRSF-Series – Model Code

VR	S	F	-	-	15	C	-	19HB16
----	---	---	---	---	----	---	---	--------

Mount code (*1)

Reducer frame size: B, C, D, E

Ratio
1stage: 3, 5, S9
2stage: 15, 20, 25, 35, 45, 81

Backlash specification
Symbol: Standard
PB: High-precision
LB: Low-backlash

Backlash*

Frame Size	VR-□ (Standard)	VR-LB (Low-Backlash)	VR-PB (High-Precision)
B frame	0.25° (15 arc-minutes)	0.166° (10 arc-minutes)	0.05° (3 arc-minutes)
C frame	0.25° (15 arc-minutes)	0.08° (5 arc-minutes)	0.05° (3 arc-minutes)
D frame	0.25° (15 arc-minutes)	0.08° (5 arc-minutes)	0.05° (3 arc-minutes)
E frame	0.25° (15 arc-minutes)	0.08° (5 arc-minutes)	0.05° (3 arc-minutes)

*Values obtained by multiplying the output shaft speed by a load of ±5% of allowable output torque.

Output specification F: F-flange - Installation style is not limited

Input selection Clamp collar (The motor shaft is provided without key-way, but can be used with a keyed motor shaft.)

Model name for ABLE reducer

SHIMPO's adapter flange motor mounting methodology allows for nearly limitless motor mounting options

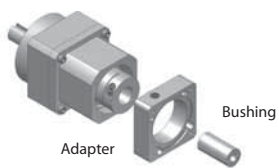

Adapter Bushing

*1) Mount code varies depending on the motor.
Please refer to reducer selection tool or contact us for more information.

■ Output shaft tapping
B frame: M5 × 10 C frame: M6 × 12 D frame: M8 × 16 E frame: M10 × 20

Metric and NEMA Output Flange

Refer to page 30-31 for Metric and NEMA Output Flange

Contact us for additional information or refer to our online reducer selection tool.

Selection tool www.nidec-shimpo.co.jp/selection/eng



Sold & Serviced By:

ELECTROMATE

Toll Free Phone (877) SERV098

Toll Free Fax (877) SERV099

www.electromate.com

sales@electromate.com

VRSF B-Frame – 1-Stage and 2-Stage Specifications

Frame Size	B								
Stage	1-Stage					2-Stage			
Ratio	Units	Note	3	5	9	15	20	25	35
Nominal Output Torque	[Nm]	--	3.43	2.84	2.35	4.02	5.00	6.27	3.84
Maximum Acceleration Torque	[Nm]	--	10.3	8.53	7.25	12.2	15.0	19.0	11.5
Emergency Stop Torque	[Nm]	--	--	--	--	--	--	--	--
Nominal Input Speed	[rpm]	--	3000			3000			
Maximum Input Speed	[rpm]	*1	5000			5000			
No Load Running Torque	[Nm]	--	0.119			0.048			
Permitted Radial Load	[N]	*2	392	490	588	784	804	882	882
Permitted Axial Load	[N]	*3	196	245	294	392	402	441	441
Moment of Inertia ($\leq \emptyset 8$)	[kgcm ²]	*4	0.081	0.059	0.052	0.057	0.056	0.056	0.052
Moment of Inertia ($\leq \emptyset 14$)	[kgcm ²]	*4	0.150	0.130	0.120	0.130	0.130	0.130	0.120
Efficiency	[%]	--	90			85			
Torsional Rigidity	[Nm/arcmin]	--	0.8			0.8			
Backlash (Standard)	[Arc-min]	--	≤ 15			≤ 15			
Backlash (Low)	[Arc-min]	--	≤ 10			≤ 10			
Backlash (Precision)	[Arc-min]	--	≤ 3			≤ 3			
Noise Level	[dB]	--	≤ 72			≤ 65			
Protection Class	--	--	IP65			IP65			
Ambient Temperature	[°C]	--	0-40			0-40			
Permitted Housing Temperature	[°C]	--	90			90			
Weight ($\leq \emptyset 8$)	[kg]	*5	0.58			0.75			
Weight ($\leq \emptyset 14$)	[kg]	*5	0.7			0.86			

- *1) Nominal input speed is 3,000 rpm or less
- *2) Permitted radial load is measured at the middle of the output shaft
- *3) Permitted thrust load is measured at the center of the output shaft
- *4) The moment of inertia is reflected to the input shaft of the reducer
- *5) The weight varies slightly depending on the input bore size and reduction ratio

Refer to page 30-31 for Metric and NEMA Output Flange

VRSF C-Frame – 1-Stage and 2-Stage Specifications

Frame Size	C										
Stage	1-Stage					2-Stage					
Ratio	Units	Note	3	5	9	15	20	25	35	45	81
Nominal Output Torque	[Nm]	--	6.86	11.5	9.7	16.2	21.1	26.4	15.5	9.5	9.7
Maximum Acceleration Torque	[Nm]	--	20.6	34.3	29.2	48.6	63.3	79.2	46.6	28.6	29.2
Emergency Stop Torque	[Nm]	--	--	--	--	--	--	--	--	--	--
Nominal Input Speed	[rpm]	--	3000			3000					
Maximum Input Speed	[rpm]	*1	5000			5000					
No Load Running Torque	[Nm]	--	0.29			0.19					
Permitted Radial Load	[N]	*2	784	980	1180	1470	1570	1670	1670	1670	1670
Permitted Axial Load	[N]	*3	392	490	588	735	785	833	833	833	833
Moment of Inertia ($\leq \varnothing 8$)	[kgcm ²]	*4	--	--	--	0.077	0.070	0.062	0.055	0.053	0.052
Moment of Inertia ($\leq \varnothing 14$)	[kgcm ²]	*4	0.630	0.380	0.300	0.150	0.140	0.130	0.130	0.120	0.120
--	--	*4	1.100	0.880	0.800	--	--	--	--	--	--
Efficiency	[%]	--	90			85					
Torsional Rigidity	[Nm/arcmin]	--	3			3					
Backlash (Standard)	[Arc-min]	--	≤ 15			≤ 15					
Backlash (Low)	[Arc-min]	--	≤ 5			≤ 5					
Backlash (Precision)	[Arc-min]	--	≤ 3			≤ 3					
Noise Level	[dB]	--	≤ 72			≤ 65					
Protection Class	--	--	IP 65			IP65					
Ambient Temperature	[°C]	--	0-40			0-40					
Permitted Housing Temperature	[°C]	--	90			90					
Weight ($\leq \varnothing 8$)	[kg]	*5	--			1.8					
Weight ($\leq \varnothing 14$)	[kg]	*5	1.8			1.9					
Weight ($\leq \varnothing 19$)	--	--	2.2			--					

*1) Nominal input speed is 3,000 rpm or less

*2) Permitted radial load is measured at the middle of the output shaft

*3) Permitted thrust load is measured at the center of the output shaft

*4) The moment of inertia is reflected to the input shaft of the reducer

*5) The weight varies slightly depending on the input bore size and reduction ratio

Refer to page 30-31 for Metric and NEMA Output Flange

Sold & Serviced By:

 **ELECTROMATE**

Toll Free Phone (877) SERV098

Toll Free Fax (877) SERV099

www.electromate.com

sales@electromate.com

VRSF D-Frame – 1-Stage and 2-Stage Specifications

Frame Size	D										
Stage	1-Stage					2-Stage					
Ratio	Units	Note	3	5	9	15	20	25	35	45	81
Nominal Output Torque	[Nm]	--	18.3	23.5	18.2	30.4	40.6	50.7	37	28.3	17.8
Maximum Acceleration Torque	[Nm]	--	54.9	70.6	54.7	91.2	122	152	111	85.2	53.5
Emergency Stop Torque	[Nm]	--	--	--	--	--	--	--	--	--	--
Nominal Input Speed	[rpm]	--	3000			3000					
Maximum Input Speed	[rpm]	*1	5000			5000					
No Load Running Torque	[Nm]	--	0.51			0.26					
Permitted Radial Load	[N]	*2	882	1080	1470	1760	1910	2060	2060	2060	2060
Permitted Axial Load	[N]	*3	441	539	735	882	955	1030	1030	1030	1030
Moment of Inertia ($\leq \emptyset 8$)	[kgcm ²]	*4	--	--	--	--	--	--	--	--	0.10
Moment of Inertia ($\leq \emptyset 14$)	[kgcm ²]	*4	1.30	0.59	0.38	0.37	0.35	0.34	0.30	0.29	0.29
Moment of Inertia ($\leq \emptyset 19$)	[kgcm ²]	*4	1.80	1.10	0.90	0.86	0.84	0.83	0.79	0.78	0.77
Moment of Inertia ($\leq \emptyset 28$)	[kgcm ²]	*4	3.60	2.90	2.70	2.70	2.70	2.70	--	--	--
Efficiency	[%]	--	90			85					
Torsional Rigidity	[Nm/arcmin]	--	6			6					
Backlash (Standard)	[Arc-min]	--	≤ 15			≤ 15					
Backlash (Low)	[Arc-min]	--	≤ 5			≤ 5					
Backlash (Precision)	[Arc-min]	--	≤ 3			≤ 3					
Noise Level	[dB]	--	≤ 72			≤ 65					
Protection Class	--	--	IP65			IP65					
Ambient Temperature	[°C]	--	0-40			0-40					
Permitted Housing Temperature	[°C]	--	90			90					
Weight ($\leq \emptyset 8$)	[kg]	*5	--			2.8					
Weight ($\leq \emptyset 14$)	[kg]	*5	2.8			3.3					
Weight ($\leq \emptyset 19$)	[kg]	*5	3.2			3.7					
Weight ($\leq \emptyset 28$)	[kg]	*5	4.0			4.8					

- *1) Nominal input speed is 3,000 rpm or less
- *2) Permitted radial load is measured at the middle of the output shaft
- *3) Permitted thrust load is measured at the center of the output shaft
- *4) The moment of inertia is reflected to the input shaft of the reducer
- *5) The weight varies slightly depending on the input bore size and reduction ratio

Refer to page 30-31 for Metric and NEMA Output Flange

VRSF E-Frame – 1-Stage and 2-Stage Specifications

Frame Size	E										
Stage	1-Stage					2-Stage					
Ratio	Units	Note	3	5	9	15	20	25	35	45	81
Nominal Output Torque	[Nm]	--	44.1	56.8	73.5	91.4	78.4	65.4	71	91.3	43.3
Maximum Acceleration Torque	[Nm]	--	132	171	221	274	235	196	213	274	130
Emergency Stop Torque	[Nm]	--	--	--	--	--	--	--	--	--	--
Nominal Input Speed	[rpm]	--	3000			3000					
Maximum Input Speed	[rpm]	*1	5000			5000					
No Load Running Torque	[Nm]	--	1.12			0.62					
Permitted Radial Load	[N]	*2	1370	1670	1960	2350	2500	2650	3430	3520	3530
Permitted Axial Load	[N]	*3	686	833	980	1180	1250	1320	1715	1760	1765
Moment of Inertia ($\leq \emptyset 8$)	[kgcm ²]	*4	--	--	0.61	0.63	0.56	0.53	0.40	0.35	0.34
Moment of Inertia ($\leq \emptyset 14$)	[kgcm ²]	*4	4.40	1.90	1.20	1.10	1.10	1.00	0.90	0.85	0.84
Moment of Inertia ($\leq \emptyset 19$)	[kgcm ²]	*4	6.20	3.70	2.90	3.30	3.20	3.20	2.80	2.70	2.70
Moment of Inertia ($\leq \emptyset 28$)	[kgcm ²]	*4	14.00	11.00	11.00	11.00	11.00	11.00	--	--	--
Efficiency	[%]	--	90			85					
Torsional Rigidity	[Nm/arcmin]	--	20			20					
Backlash (Standard)	[Arc-min]	--	≤ 15			≤ 15					
Backlash (Low)	[Arc-min]	--	≤ 5			≤ 5					
Backlash (Precision)	[Arc-min]	--	≤ 3			≤ 3					
Noise Level	[dB]	--	≤ 75			≤ 75					
Protection Class	--	--	IP65			IP65					
Ambient Temperature	[°C]	--	0-40			0-40					
Permitted Housing Temperature	[°C]	--	90			90					
Weight ($\leq \emptyset 8$)	[kg]	*5	6.1			7.1					
Weight ($\leq \emptyset 14$)	[kg]	*5	6.5			7.5					
Weight ($\leq \emptyset 19$)	[kg]	*5	7.4			9.3					
Weight ($\leq \emptyset 28$)	[kg]	*5	9.8			11.7					

*1) Nominal input speed is 3,000 rpm or less

*2) Permitted radial load is measured at the middle of the output shaft

*3) Permitted thrust load is measured at the center of the output shaft

*4) The moment of inertia is reflected to the input shaft of the reducer

*5) The weight varies slightly depending on the input bore size and reduction ratio

Refer to page 30-31 for Metric and NEMA Output Flange

Sold & Serviced By:

 **ELECTROMATE**

Toll Free Phone (877) SERV098

Toll Free Fax (877) SERV099

www.electromate.com

sales@electromate.com

VRSF-SERIES Inline shaft

VRSF B-Frame – 1-Stage and 2-Stage Dimensions

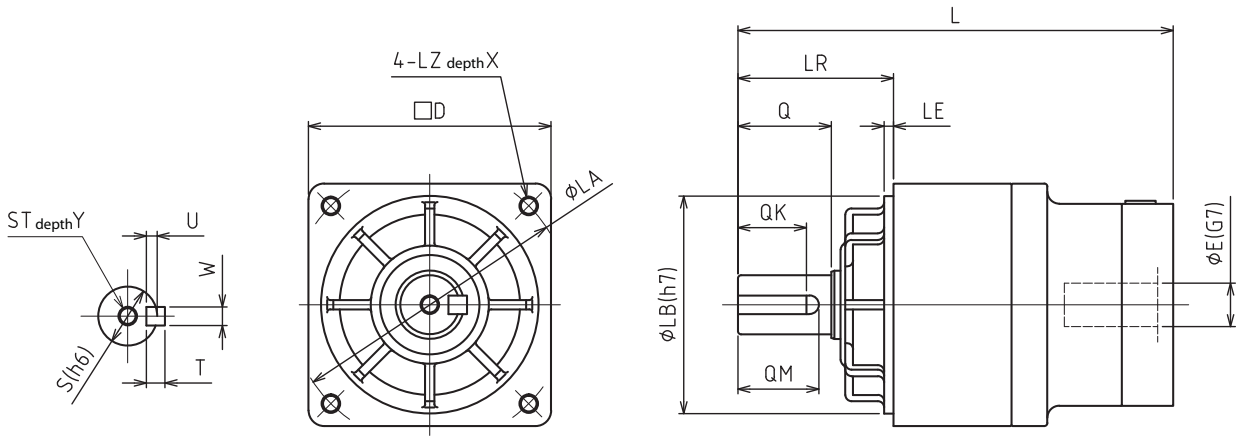

Frame Size	Ratio*	Input Bore Dia. E**	Dimensions															
			L***	LR	S	ST	Y	Q	QM	QK	W×U	T	D	LB	LE	LA	LZ	X
B	1-Stage	≤ φ8	104.5	32	12	M5	10	20	18	16	4×2.5	4	52	50	3	60	M5	12
		≤ φ14	107.5															
	2-Stage	≤ φ8	115.5															
		≤ φ14	118.5															

*1) Single reduction : 1/3 - 1/S9, Double reduction : 1/15 - 1/81 (1/15 - 1/35 for B frame)

*2) Bushing will be inserted to adapt to motor shaft

Sold & Serviced By:

Toll Free Phone (877) SERV098
 Toll Free Fax (877) SERV099
www.electromate.com
sales@electromate.com

VRSF B-Frame – 1-Stage and 2-Stage Adapter Dimensions

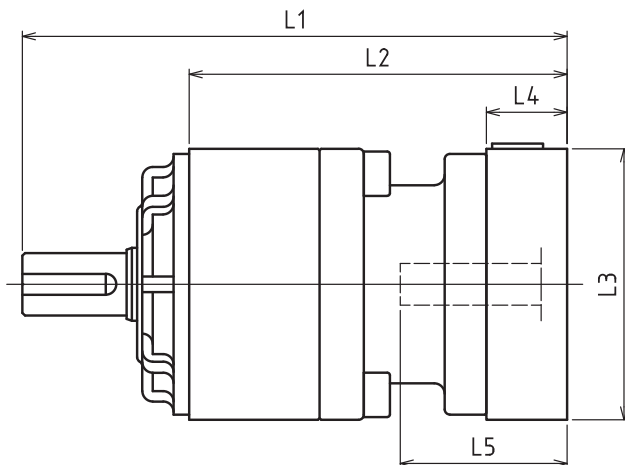

Model number	**: Adapter code	1-Stage					2-Stage				
		L1	L2	L3	L4	L5	L1	L2	L3	L4	L5
VRSF-□-□B-8** (Input shaft bore ≤ φ8)	AA·AC·AD·AF·AG·AL·AM·AN·AQ	104.5	72.5	□52	15.5	32	115.5	83.5	□52	15.5	32
	AB·AE·AH·AJ·AK	109.5	77.5	□52	20.5	37	120.5	88.5	□52	20.5	37
	BA·BB·BD·BE·BG·BH·BJ	104.5	72.5	□60	15.5	32	115.5	83.5	□60	15.5	32
	BC·BF	109.5	77.5	□60	20.5	37	120.5	88.5	□60	20.5	37
	CA	109.5	77.5	□70	20.5	37	120.5	88.5	□70	20.5	37
VRSF-□-□B-14** (Input shaft bore ≤ φ14)	BA·BB·BD·BE·BF·BG·BH·BJ·BK·BP	107.5	75.5	□65	16.5	35	118.5	86.5	□65	16.5	35
	BC·BH·BM·BN	112.5	80.5	□65	21.5	40	123.5	91.5	□65	21.5	40
	BL	117.5	85.5	□65	26.5	45	128.5	96.5	□65	26.5	45
	CA·CC	107.5	75.5	□70	16.5	35	118.5	86.5	□70	16.5	35
	CB	112.5	80.5	□70	21.5	40	123.5	91.5	□70	21.5	40
	DA·DB·DC·DD·DF·DH·DJ	107.5	75.5	□80	16.5	35	118.5	86.5	□80	16.5	35
	DE·DL	112.5	80.5	□80	21.5	40	123.5	91.5	□80	21.5	40
	DG·DK	117.5	85.5	□80	26.5	45	128.5	96.5	□80	26.5	45
	EA·EB·EC·EF·EG·EK·EL	107.5	75.5	□90	16.5	35	118.5	86.5	□90	16.5	35
	EJ·EM	112.5	80.5	□90	21.5	40	123.5	91.5	□90	21.5	40
	ED·EE·EH	117.5	85.5	□90	26.5	45	128.5	96.5	□90	26.5	45
	FA	107.5	75.5	□100	16.5	35	118.5	86.5	□100	16.5	35
	FB	107.5	75.5	□115	16.5	35	118.5	86.5	□115	16.5	35

*1) Single reduction : 1/3 - 1/5, Double reduction : 1/15 - 1/35

*2) Bushing will be inserted to adapt to motor shaft

For an explanation on the Adapter Flange Code, please turn to page 422.

A more comprehensive adapter flange offering can be found using the NIDEC-SHIMPO Online Selector Tool. The variety is constantly expanding and being updated on the Selector Tool. If you have any questions or need any support, contact NIDEC-SHIMPO.

VRSF-SERIES Inline shaft

VRSF C-Frame – 1-Stage and 2-Stage Dimensions

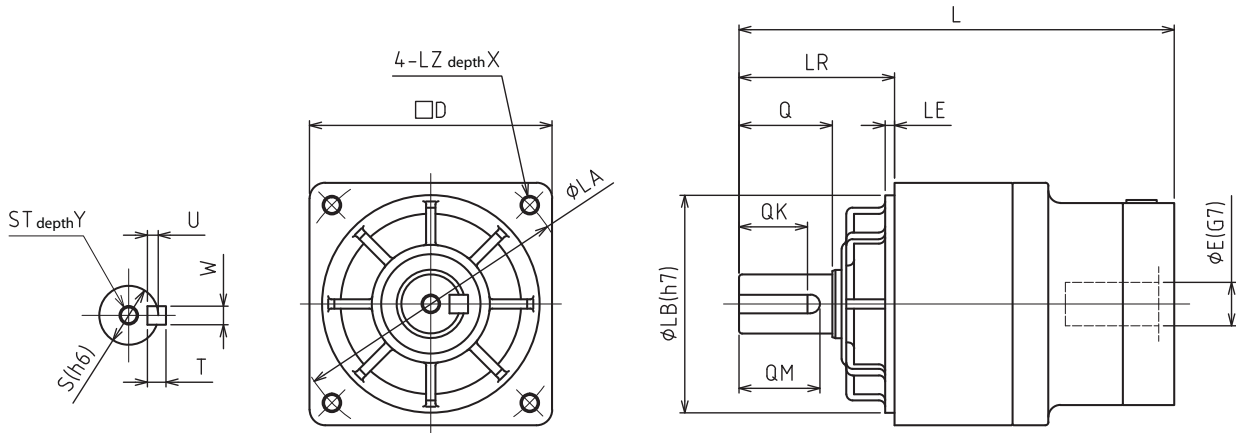

Frame Size	Ratio*	Input Bore Dia. E**	Dimensions															
			L***	LR	S	ST	Y	Q	QM	QK	W×U	T	D	LB	LE	LA	LZ	X
C	1-Stage	$\cong \phi 14$	140	50	19	M6	12	30	26	22	6×3.5	6	78	70	3	90	M6	20
		$\cong \phi 19$	156															
	2-Stage	$\cong \phi 8$	147.5															
		$\cong \phi 14$	150.5															

*1) Single reduction : 1/3 - 1/59, Double reduction : 1/15 - 1/81 (1/15 - 1/35 for B frame)

*2) Bushing will be inserted to adapt to motor shaft

VRSF C-Frame – 1-Stage and 2-Stage Adapter Dimensions

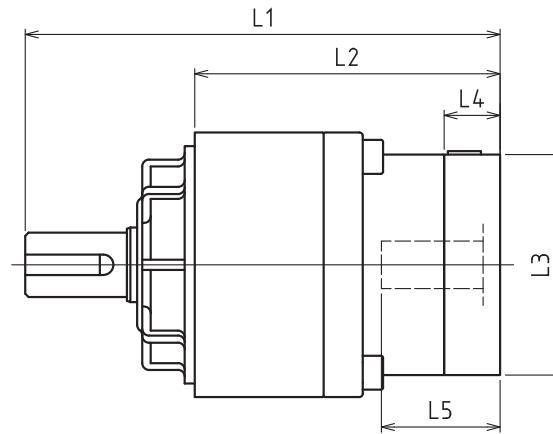

Model number	**: Adapter code	1-Stage					2-Stage				
		L1	L2	L3	L4	L5	L1	L2	L3	L4	L5
VRSF-□-□C-8** (Input shaft bore ≤ φ8)	AA·AC·AD·AF·AG·AL·AM·AN·AQ	--	--	--	--	--	147.5	97.5	□52	15.5	32
	AB·AE·AH·AJ·AK	--	--	--	--	--	152.5	102.5	□52	20.5	37
	BA·BB·BD·BE·BG·BH·BJ	--	--	--	--	--	147.5	97.5	□60	15.5	32
	BC·BF	--	--	--	--	--	152.5	102.5	□60	20.5	37
	CA	--	--	--	--	--	152.5	102.5	□70	20.5	37
VRSF-□-□C-14** (Input shaft bore ≤ φ14)	BA·BB·BD·BE·BF·BG·BH·BJ·BK·BP	140	90	□65	16.5	35	150.5	100.5	□65	16.5	35
	BC·BH·BM·BN	145	95	□65	21.5	40	155.5	105.5	□65	21.5	40
	BL	150	100	□65	26.5	45	160.5	110.5	□65	26.5	45
	CA·CC	140	90	□70	16.5	35	150.5	100.5	□70	16.5	35
	CB	145	95	□70	21.5	40	155.5	105.5	□70	21.5	40
	DA·DB·DC·DD·DF·DH·DJ	140	90	□80	16.5	35	150.5	100.5	□80	16.5	35
	DE·DL	145	95	□80	21.5	40	155.5	105.5	□80	21.5	40
	DG·DK	150	100	□80	26.5	45	160.5	110.5	□80	26.5	45
	EA·EB·EC·EF·EG·EK·EL	140	90	□90	16.5	35	150.5	100.5	□90	16.5	35
	EJ·EM	145	95	□90	21.5	40	155.5	105.5	□90	21.5	40
	ED·EE·EH	150	100	□90	26.5	45	160.5	110.5	□90	26.5	45
	FA	140	90	□100	16.5	35	150.5	100.5	□100	16.5	35
	FB	140	90	□115	16.5	35	150.5	100.5	□115	16.5	35
VRSF-□-□C-19** (Input shaft bore ≤ φ19)	DA·DB·DC	156	106	□80	25	50	--	--	--	--	--
	DD	166	116	□80	35	60	--	--	--	--	--
	DE	161	111	□80	30	55	--	--	--	--	--
	EA	161	111	□90	30	55	--	--	--	--	--
	EB·ED	156	106	□90	25	50	--	--	--	--	--
	EC	166	116	□90	35	60	--	--	--	--	--
	FA	156	106	□100	25	50	--	--	--	--	--
	FB	166	116	□100	35	60	--	--	--	--	--
	GA·GC·GH	161	111	□115	30	55	--	--	--	--	--
	GB·GD·GJ	156	106	□115	25	50	--	--	--	--	--
	GE·GF	166	116	□115	35	60	--	--	--	--	--
	HA	156	106	□130	25	50	--	--	--	--	--
	HB	171	121	□130	40	65	--	--	--	--	--
	HC·HD·HE	161	111	□130	30	55	--	--	--	--	--
	JA	166	116	□150	35	60	--	--	--	--	--
JB	171	121	□150	40	65	--	--	--	--	--	

*1) Single reduction : 1/3 - 1/59, Double reduction : 1/15 - 1/81

*2) Bushing will be inserted to adapt to motor shaft

For an explanation on the Adapter Flange Code, please turn to page 422.

A more comprehensive adapter flange offering can be found using the NIDEC-SHIMPO Online Selector Tool. The variety is constantly expanding and is updated on the Selector Tool. If you have any questions or need any support, contact NIDEC-SHIMPO.

VRSF-SERIES Inline shaft

VRSF D-Frame – 1-Stage and 2-Stage Dimensions

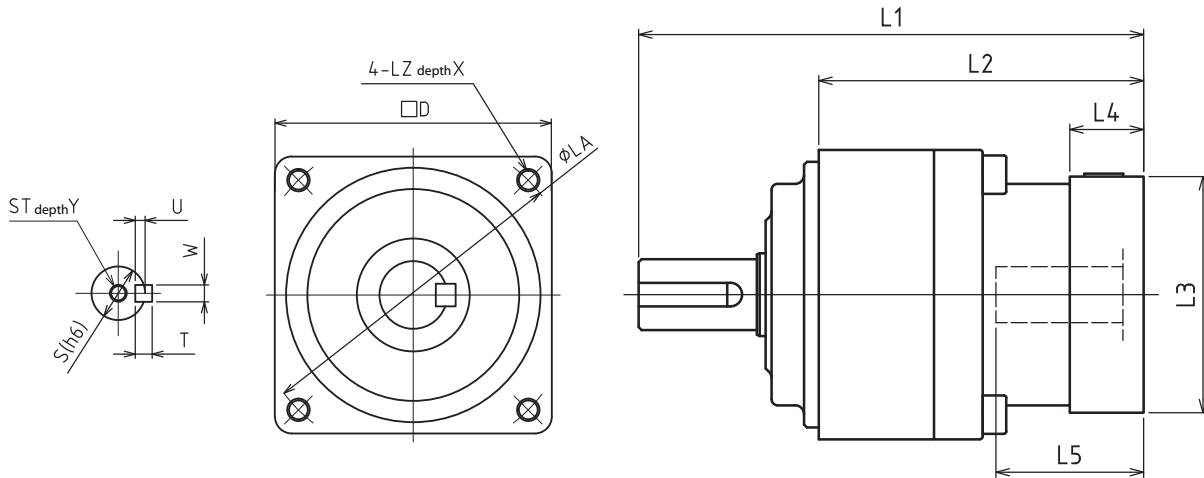

Frame Size	Ratio*	Input Bore Dia. E**	Dimensions															
			L***	LR	S	ST	Y	Q	QM	QK	W×U	T	D	LB	LE	LA	LZ	X
D	1-Stage	≅ φ14	155	61	24	M8	16	40	35	30	8×4	7	98	90	5	115	M8	20
		≅ φ19	171															
		≅ φ28	186															
	2-Stage	≅ φ8	163															
		≅ φ14	169															
		≅ φ19	184															
		≅ φ28	200.5															

*1) Single reduction : 1/3 - 1/59, Double reduction : 1/15 - 1/81 (1/15 - 1/35 for B frame)

*2) Bushing will be inserted to adapt to motor shaft

VRSF D-Frame – 1-Stage and 2-Stage Adapter Dimensions

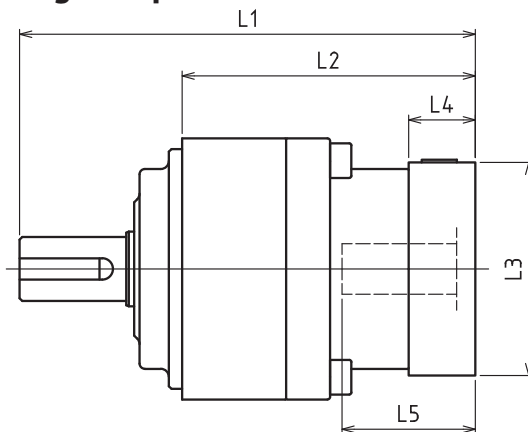

Model number	**: Adapter code	1-Stage					2-Stage				
		L1	L2	L3	L4	L5	L1	L2	L3	L4	L5
VRSF-□-□D-8** (Input shaft bore ≤ φ8)	AA·AC·AD·AF·AG·AL·AM·AN·AQ	--	--	--	--	--	163	102	□52	15.5	32
	AB·AE·AH·AJ·AK	--	--	--	--	--	168	107	□52	20.5	37
	BA·BB·BD·BE·BG·BH·BJ	--	--	--	--	--	163	102	□60	15.5	32
	CA	--	--	--	--	--	168	107	□70	20.5	37
VRSF-□-□D-14** (Input shaft bore ≤ φ14)	BA·BB·BD·BE·BF·BG·BH·BJ·BK·BP	155	94	□65	16.5	35	169	108	□65	16.5	35
	BC·BH·BM·BN	160	99	□65	21.5	40	174	113	□65	21.5	40
	CA·CC	155	94	□70	16.5	35	169	108	□70	16.5	35
	DA·DB·DC·DD·DF·DH·DJ	155	94	□80	16.5	35	169	108	□80	16.5	35
	EA·EB·EC·EF·EG·EK·EL	155	94	□90	16.5	35	169	108	□90	16.5	35
	FA	155	94	□100	16.5	35	169	108	□100	16.5	35
	FB	165	104	□100	26.5	45	179	118	□100	26.5	45
VRSF-□-□D-19** (Input shaft bore ≤ φ19)	JA	170	109	□150	31.5	50	184	123	□115	31.5	50
	DA·DB·DC	171	110	□80	25	50	184	123	□80	25	50
	EB·ED	171	110	□90	25	50	184	123	□90	25	50
	FA	171	110	□100	25	50	184	123	□100	25	50
	FB	181	120	□100	35	60	194	133	□100	35	60
	GB·GD·GJ	171	110	□115	25	50	184	123	□115	25	50
	HA	171	110	□130	25	50	184	123	□130	25	50
	HB	186	125	□130	40	65	199	138	□130	40	65
	HC·HD·HE	176	115	□130	30	55	189	128	□130	30	55
VRSF-□-□D-28** (Input shaft bore ≤ φ28)	JA	181	120	□150	35	60	194	133	□150	35	60
	JB	186	125	□150	40	65	199	138	□150	40	65
	FA·FB·FC	186	125	□100	35	67	200.5	139.5	□100	35	67
	FD·FE	181	120	□100	30	62	195.5	134.5	□100	30	62
	GA·GB·GC·GD·GE·GF·GG·GH	186	125	□115	35	67	200.5	139.5	□115	35	67
	HA·HC·HD	186	125	□130	35	67	200.5	139.5	□130	35	67
	HB	196	135	□130	45	77	210.5	149.5	□130	45	77
	HE	201	140	□130	50	82	215.5	154.5	□130	50	82
	HF	181	120	□130	30	62	195.5	134.5	□130	30	62
	JA·JB·JC·JF	186	125	□150	35	67	200.5	139.5	□150	35	67
	JD	206	145	□150	55	87	220.5	159.5	□150	55	87
	JE	210.5	149.5	□150	45	77	210.5	149.5	□150	45	77
VRSF-□-□D-28** (Input shaft bore ≤ φ28)	KA·KB	186	125	□180	35	67	200.5	139.5	□180	35	67
	KD	196	135	□180	45	77	210.5	149.5	□180	45	77

*1) Single reduction : 1/3 - 1/59, Double reduction : 1/15 - 1/81

*2) Bushing will be inserted to adapt to motor shaft

For an explanation on the Adapter Flange Code, please turn to page 422.

A more comprehensive adapter flange offering can be found using the NIDEC-SHIMPO Online Selector Tool. The variety is constantly expanding and is updated on the Selector Tool. If you have any questions or need any support, contact NIDEC-SHIMPO.

Sold & Serviced By:

ELECTROMATE

Toll Free Phone (877) SERV098

and (877) SERV099

www.electromate.com

sales@electromate.com

VRSF-SERIES Inline shaft

VRSF E-Frame – 1-Stage and 2-Stage Dimensions

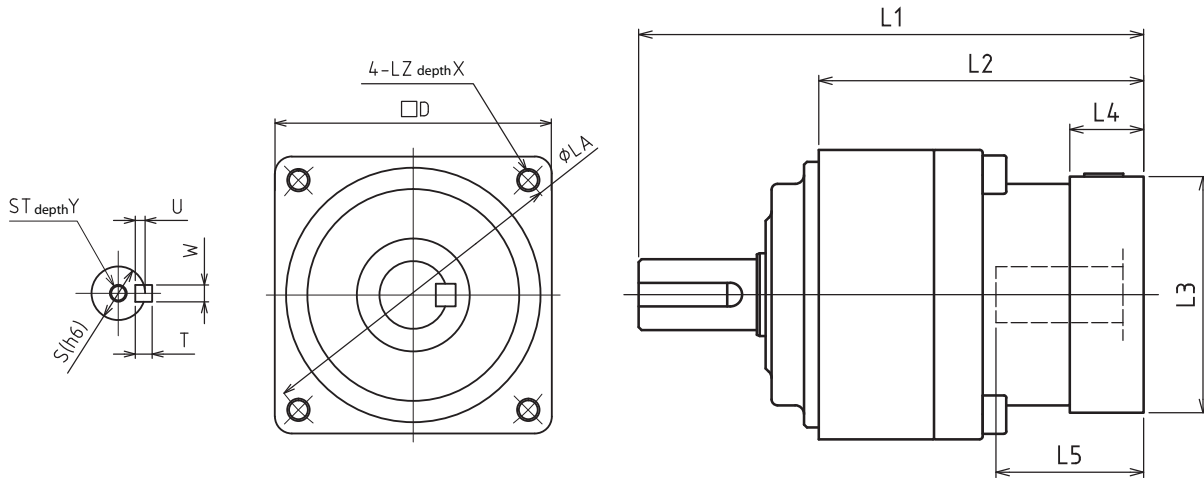

Frame Size	Ratio*	Input Bore Dia. E**	Dimensions															
			L***	LR	S	ST	Y	Q	QM	QK	W×U	T	D	LB	LE	LA	LZ	X
E	1-Stage	≅ φ14	189	75	32	M10	20	55	52	45	10×5	8	125	110	5	135	M10	20
		≅ φ19	198.5															
		≅ φ28	224															
		≅ φ38	240															
	2-Stage	≅ φ14	210															
		≅ φ19	225															
		≅ φ28	246.5															
		≅ φ38	261.5															

*1) Single reduction : 1/3 - 1/5₉, Double reduction : 1/15 - 1/81 (1/15 - 1/35 for B frame)

*2) Bushing will be inserted to adapt to motor shaft

VRSF E-Frame – 1-Stage and 2-Stage Adapter Dimensions

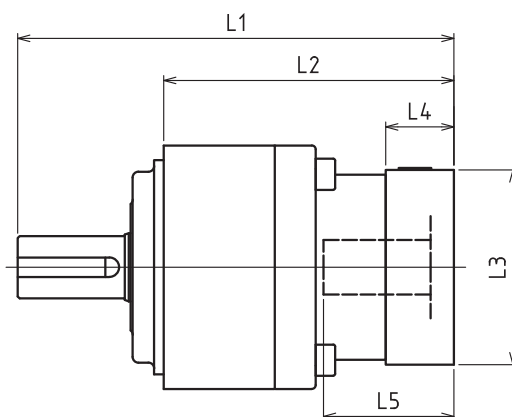

Model number	**: Adapter code	1-Stage					2-Stage				
		L1	L2	L3	L4	L5	L1	L2	L3	L4	L5
VRSF-□-□E-14** (Input shaft bore ≤ φ14)	BA•BB•BD•BE•BF•BG•BH•BJ•BK•BP	189	114	□ 65	16.5	35	210	135	□65	16.5	35
	BC•BH•BM•BN	194	119	□65	21.5	40	215	140	□65	21.5	40
	CA•CC	189	114	□70	16.5	35	210	135	□70	16.5	35
	DA•DB•DC•DD•DF•DH•DJ	189	114	□80	16.5	35	210	135	□80	16.5	35
	EA•EB•EC•EF•EG•EK•EL	189	114	□90	16.5	35	210	135	□90	16.5	35
	FA	189	114	□100	16.5	35	210	135	□100	16.5	35
	FB	199	124	□100	26.5	45	220	145	□100	26.5	45
VRSF-□-□E-19** (Input shaft bore ≤ φ19)	DA•DB•DC	198.5	123.5	□80	25	50	225	150	□80	25	50
	EB•ED	198.5	123.5	□90	25	50	225	150	□90	25	50
	FA	198.5	123.5	□100	25	50	225	150	□100	25	50
	FB	208.5	133.5	□100	35	60	235	160	□100	35	60
	GB•GD•GJ	198.5	123.5	□115	25	50	225	150	□115	25	50
	HA	198.5	123.5	□130	25	50	225	150	□130	25	50
	HB	213.5	138.5	□130	40	65	240	165	□130	40	65
VRSF-□-□E-28** (Input shaft bore ≤ φ28)	JA	208.5	133.5	□150	35	60	235	160	□150	35	60
	FA•FB•FC	224	149	□100	35	67	246.5	171.5	□100	35	67
	GA•GB•GC•GD•GE•GF•GG•GH	224	149	□115	35	67	246.5	171.5	□115	35	67
	HA•HC•HD	224	149	□130	35	67	246.5	171.5	□130	35	67
	HB	234	159	□130	45	77	256.5	181.5	□130	45	77
	HF	119	144	□130	30	62	241.5	166.5	□130	30	62
	JA•JB•JC•JF	224	149	□150	35	67	246.5	171.5	□150	35	67
	KA•KB•KE	224	149	□180	35	67	246.5	171.5	□180	35	67
	LA	224	149	□200	35	67	246.5	171.5	□200	35	67
	LB	234	159	□200	45	77	256.5	181.5	□200	45	77
VRSF-□-□E-38** (Input shaft bore ≤ φ38)	MA	224	149	□220	35	67	246.5	171.5	□220	35	67
	MB	234	159	□220	45	77	256.5	181.5	□220	45	77
	HA	240	165	□130	45	82	261.5	186.5	□130	45	82
	HB•HE	235	160	□130	40	77	256.5	181.5	□130	40	77
	JA	240	165	□150	45	82	261.5	186.5	□150	45	82
	KA•KB•KC	240	165	□180	45	82	261.5	186.5	□180	45	82
	KD	275	200	□180	80	117	296.5	221.5	□180	80	117
KE	255	180	□180	60	97	276.5	201.5	□180	60	97	
MA•MB	240	165	□220	45	82	261.5	186.5	□220	45	82	

*1) Single reduction : 1/3 - 1/59, Double reduction : 1/15 - 1/81

*2) Bushing will be inserted to adapt to motor shaft

For an explanation on the Adapter Flange Code, please turn to page 422.

A more comprehensive adapter flange offering can be found using the NIDEC-SHIMPO Online Selector Tool. The variety is constantly expanding and is updated on the Selector Tool. If you have any questions or need any support, contact NIDEC-SHIMPO.

Sold & Serviced By:

ELECTROMATE

Toll Free Phone (877) SERV098

and (877) SERV099

www.electromate.com

sales@electromate.com

VRSF Optional Metric Output Flange

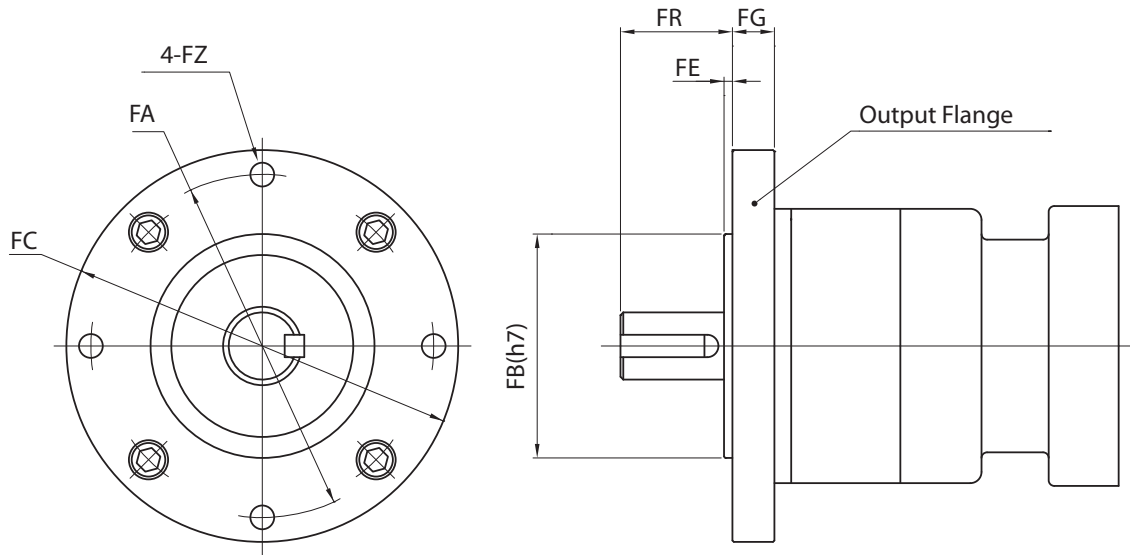

Frame Size		FG	FR	FE	FB	FC	FA	FZ
B	mm	8	24	3	50	75	65	6
	inch	0.315	0.945	0.118	1.969	2.953	2.559	0.236
C	mm	12	33	3	72	110	95	7
	inch	0.472	1.299	0.118	2.835	4.331	3.74	0.276
D	mm	13	48	5	90	134	115	8.8
	inch	0.512	1.89	0.197	3.543	5.276	4.528	0.346

VRSF Optional NEMA Output Flange

VRSF

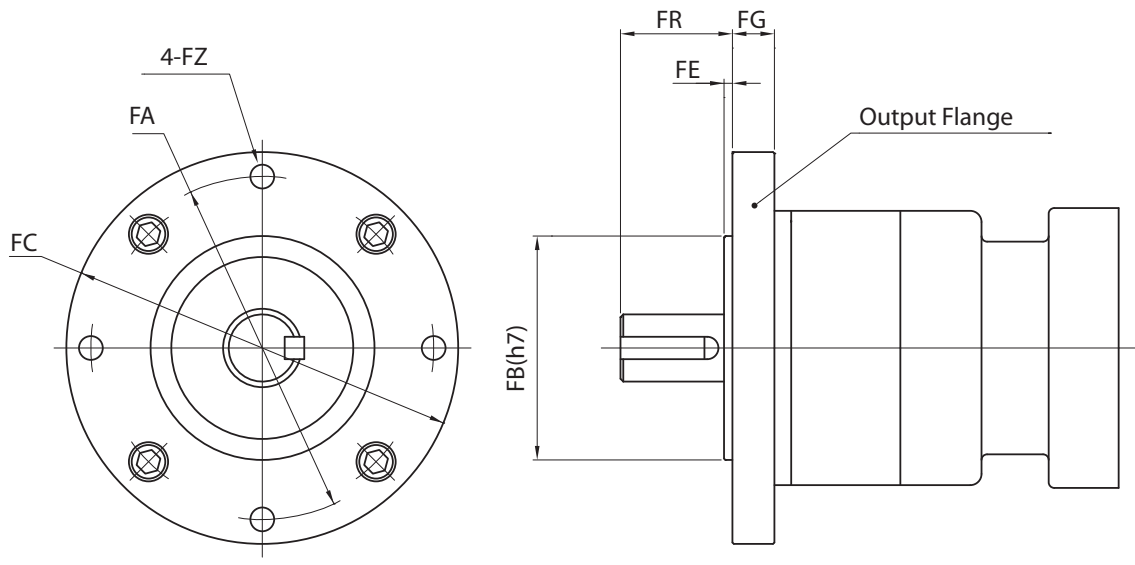

Frame Size		FG	FR	FE	FB	FC	FA	FZ
B	mm	12	20	2	38.1	78	66.68	5.2
	inch	0.472	0.787	0.079	1.5	3.071	2.625	0.205
C	mm	12	30	2	73.02	110	98.43	5.6
	inch	0.472	1.181	0.079	2.876	4.331	3.875	0.22
D	mm	15	40	3	55.56	140	125.73	7.1
	inch	0.591	1.575	0.118	2.187	5.512	4.95	0.28
E	mm	20	55	3	114.3	168	149.23	10.2
	inch	0.787	2.165	0.118	4.5	6.614	5.875	0.402