

### Sealed DC Tachometers 1 to 45 volts/1000 rpm



ST-7337A-2N and ST-7337B-1

#### Sealed Units

Servo-Tek manufactures a complete line of sealed units which are resistant against the harmful effects of fluids. These units employ a one-piece housing, a special shaft seal, and a form-fitted rubber boot on the terminal end. Servo-Tek sealed units meet electrical specifications after storage at 49°C with 95% relative humidity for 24 hours. These units are capable of enduring vibration with amplitudes up to 0.03" total excursion at frequencies from 4 Hz to 55 Hz in each of three mutually perpendicular axes with no evidence of physical damage. These units are available with a low ripple output up to 30v/1000 rpm.

#### Sealed Generator Specifications

Model Number	Mounting	Weight (Approx)	Inertia (Approx) oz-in-sec <sup>2</sup>	V/1000 rpm	RPM (max)	Arm Resist (ohms dynamic)	Armature Inductance (henrys)	Outline Dimensions	Mounting Dimensions	Shaft Size
ST-7336A-7	Face	3.0 oz	1.32 x 10 <sup>-4</sup>	2.6v	12,000	40Ω	0.024h	Fig. 8	Fig. 8	.120
ST-7336A-2	Face	3.0 oz	1.32 x 10 <sup>-4</sup>	7.0v	12,000	350Ω	0.18h	Fig. 8	Fig. 8	.120
ST-7336B-1	Face	4.0 oz	2.27 x 10 <sup>-4</sup>	20.8v	8,000	1000Ω	0.56h	Fig. 8	Fig. 8	.120
ST-7337A-2	Face	3.0 oz	1.32 x 10 <sup>-4</sup>	7.0v	12,000	350Ω	0.18h	Fig. 8	Fig. 8	.187
ST-7337B-1	Face	4.0 oz	2.27 x 10 <sup>-4</sup>	20.8v	8,000	1000Ω	0.56h	Fig. 8	Fig. 8	.187
SU-7346D-1	Flange	8.5 oz	4.54 x 10 <sup>-4</sup>	45v	5,000	1750Ω	1.00h	Fig. 8	Fig. 5	.187

Maximum Driving Torque for sealed units is 0.7 oz-in  
Most units listed above are normally in stock

### Servo-Tek's Ruggedized PY Alternative (Up to 50 volts)



ST-13212 and ST-12970

#### Ruggedized PY Alternatives

Servo-Tek ruggedized DC tachometer generators are designed with sturdy aluminum housings and strong mounting flanges. Other features offered include extra-heavy armature shafts and bearings. The mechanical flexibility of the ST-13212 allows for the internal tachometer to be repaired or replaced, without having to replace the expensive anodized casting. The ST-13212 supplies outputs from 2.6 to 50v/1000 rpm and runs at speeds up to 5000 rpm. The shaft size is 5/16" in diameter. The ST-12970 comes equipped with a silicone rubber coupling. It allows the unit to be driven by a motor shaft with 0.167" wide slot. The ST-12970 is also available with outputs up to 24v/1000 rpm and designed to run at high speeds.

# Mounting and Outline Dimensions

Figure 1 SA Face Mount

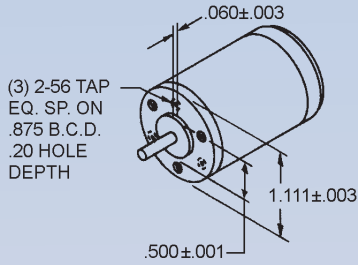

Figure 2 SB Flange Mount

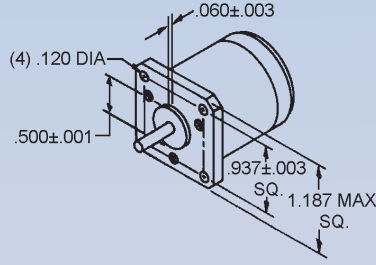

Figure 3 SD Modified Synchro

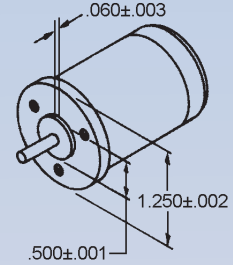

Figure 4 SM Aircraft Mount

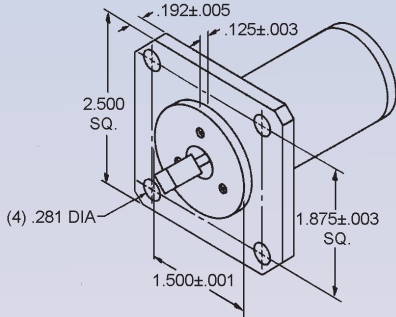

Figure 5 SU Large Flange Mount

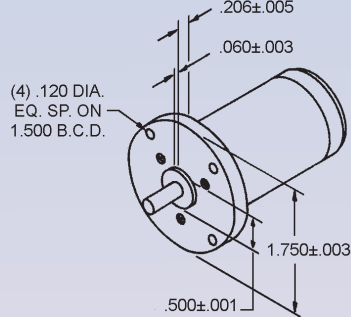

Figure 6 SS Synchro Mount

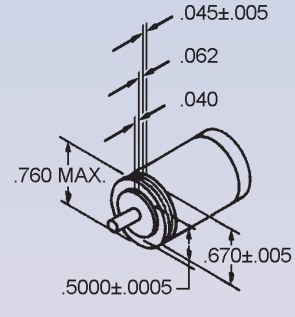
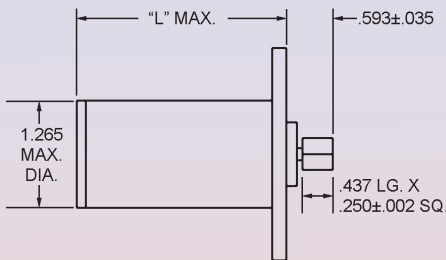
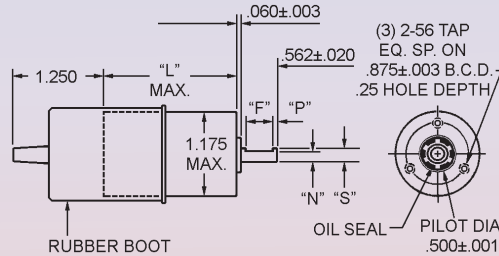

Figure 7 Aircraft Configuration



Model #	"L"
SM-762A	2.520
SM-762B	2.957

Figure 8 Sealed Configuration



Model	"L"	"F"	"P"	"N"	"S"
ST-7336A	1.867	OMIT	OMIT	OMIT	0.120 ± .001
ST-7336B	2.304	OMIT	OMIT	OMIT	0.120 ± .001
ST-7337A	1.875	0.375	0.062	0.157	0.187 ± .001
ST-7337B	2.312	0.375	0.062	0.157	0.187 ± .001

Figure 9 Flat Shaft Configuration

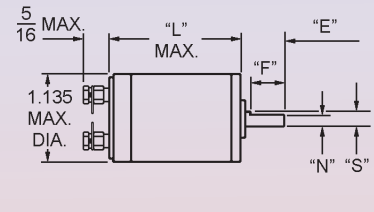

Model	"L"	"E"	"F"	"N"	"S"
XX-7114B	2.193	0.562	0.437	0.157	0.187 ± .001
XX-7114D	3.253	0.562	0.437	0.157	0.187 ± .001
XX-7146A	1.701	0.562	0.437	0.110	0.120 ± .001

Figure 10 Instrument/Industrial Configuration

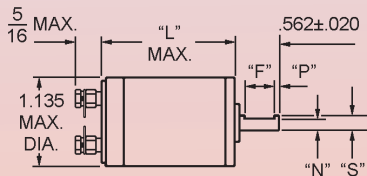

Model #	"L"	"F"	"P"	"N"	"S"
XX-740A	1.701	OMIT	OMIT	OMIT	0.120 ± .001
XX-740B	2.138	OMIT	OMIT	OMIT	0.120 ± .001
XX-780B	2.193	0.375	0.062	0.157	0.187 ± .001
XX-780D	3.253	0.375	0.062	0.157	0.187 ± .001
XX-797A	1.701	0.187	0.187	0.110	0.120 ± .001
XX-7103A	1.756	0.375	0.062	0.157	0.187 ± .001
XX-7107D	3.253	OMIT	OMIT	OMIT	0.187 ± .001
XX-7123A	1.756	OMIT	OMIT	OMIT	0.187 ± .001
XX-7123B	2.193	OMIT	OMIT	OMIT	0.187 ± .001
XX-7356F	1.701	OMIT	OMIT	OMIT	0.120 ± .001
XX-7360F	1.756	0.375	0.062	0.157	0.187 ± .001

Figure 11 Industrial Configuration

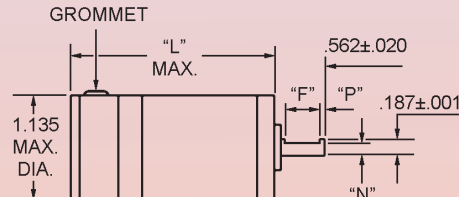

Model #	"L"	"F"	"P"	"N"
XX-757A	2.240	0.375	0.062	0.157
XX-757B	2.677	0.375	0.062	0.157
XX-796B	2.677	OMIT	OMIT	OMIT
XX-7483H	2.677	0.375	0.062	0.157

Figure 12 E-Series Tachometers

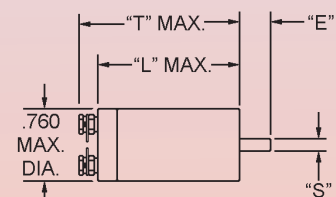

Model #	"T"	"L"	"E"	"S"
SS-779E	1.687	1.479	0.375 ± .015	0.120 ± .0005
SS-7251E	1.687	1.479	0.562 ± .015	0.187 ± .0002

Sold & Serviced By:



Toll Free Phone (877) SERV098

Toll Free Fax (877) SERV099

www.electromate.com

sales@electromate.com

### Technical Data

#### *An Industry Standard for over fifty years.*

Servo-Tek DC tachometer generators provide a convenient and economical means of converting rotational speed into an isolated analog voltage signal suitable for remote indication and control. While this catalog contains information on our most popular models, we also manufacture countless specials.

#### *Construction*

Most of our DC generators are housed in aluminum casings protected in accordance with Mil-C-5541 or Mil-A-8625 or high performance plastics. Alnico permanent magnets are used. Armature shafts are stainless-steel, and rotate on fully-shielded stainless-steel ball bearings. Commutators are manufactured from an alloy containing at least 90% silver. Armature laminations are wound with Isomid insulated wire, over Teflon slot insulation. The entire armature is then baked, resulting in a NEMA Class H insulation system.



#### *Ripple*

The ripple rms value will not exceed 3% of the DC value at any speed in excess of 40 rpm on standard units. On the low ripple units, the ripple rms value will not exceed 1.5% of the DC value. A peak to peak ripple of 1.5% is available on some models.

#### *Brush Life*

Brushes and commutators are matched for long life and stability.

#### *Linearity*

Linearity at any speed is better than 0.1% of the output at that rpm.

#### *Bidirectional Operation*

All Servo-Tek DC tachometer generators operate in either rotational direction. That direction can be determined by output voltage polarity. Output (in either direction) is held to a tolerance of 0.25% of the average output.



#### *Stability*

Optimum brush and commutator combination gives 0.1% stability. Highly stable output gives no evidence of long-term drift.

#### *Breakdown Voltage*

Servo-Tek DC tachometer generators are factory tested with an ac potential of 1250 volts rms applied for one second between (either) terminal and shaft. E-Series units are tested with 500 volts.

#### *Temperature Range*

Most of our units are designed for continuous operation in ambient temperatures ranging from -55°C to +100°C. Voltage output at 25°C will not deviate by more than 0.01% per degree of change within the range of -20°C to +75°C. All units are temperature compensated, with the exception of D-Series and E-Series units.

Sold & Serviced By:  
 **ELECTROMATE**

Toll Free Phone (877) SERV098  
Toll Free Fax (877) SERV099  
[www.electromate.com](http://www.electromate.com)  
[sales@electromate.com](mailto:sales@electromate.com)