

## QM35

### DESIGN FEATURES

- Bearingless modular design
- Full complement outputs
- Low profile assembled height of 0.43"
- Resolutions up to 8192 lines per revolution
- 4, 6, 8 or 10 pole commutation<sup>3</sup>
- Easy lock-n-twist assembly feature
- Through bore sizes up to 0.375" diameter
- Up to 1 MHz frequency response
- High noise immunity
- RoHS construction
- Hub to shaft uses two #3-48 set screws
- Hermetically sealed LED
- Multiple mounting options including resolver size 15



Quantum Devices, Inc. Model QM35 is a high performance, low profile modular design ideal for high volume OEM applications and priced competitively for all sizes of motion control projects. The QM35's versatile electrical configurations include lines counts up to 8192 and several commutation options. The QM35's patent lock-n-twist mechanism simplifies installation; saving production time and money. The QM35 is the newest solution to your motion control needs.



### Configuration Options:

Resolution <sup>3</sup>	Commutation <sup>3</sup>	Output	Cover	Bore Size	Mounting	Index	Hardware
360 <sup>4</sup> , 500, 512, 1000, 1024, 2000, 2048, 2500, 4000, 4096, 5000, 5120, 8000, 8192	0 = No Comm 4 = 4 Pole 6 = 6 Pole 8 = 8 Pole 10 = 10 Pole	A = Line Driver B = Line Driver (ABZ) / Open Collector (UVW) C = Dual Voltage - Line Driver (ABZ) / Open Collector (UVW)	A = Hole in Cover B = Closed Cover (shaft < 0.512") C = Closed Cover (shaft < 0.450")	C = 5 mm D = 6 mm E = 8 mm K = 0.1875" L = 0.250" M = 0.3125" N = 0.375"	A = 1.280" B = 1.812"	A = 90° A & B High B = 90° A & B Low	Please refer to hardware options on page 4

#### Note:

- 1.) 4 poles has four states per revolution (2 pole pair), or two 360° electrical cycles per revolution
- 2.) Mounting option A allows for resolver size 15
- 3.) Consult factory for configurations not shown
- 4.) 360 PPR not presently available with 6, 8 or 10 poles
- 5.) Line Driver (RS-422) is compatible with Renco options: TTL, PP, VC or LD. Open collector compatible with VO configurations

Sold & Serviced By:

 **ELECTROMATE**

Toll Free Phone (877) SERV098

[www.electromate.com](http://www.electromate.com)

[sales@electromate.com](mailto:sales@electromate.com)

**ISO 9001**

CERT. NO. FM 52711

## OUTPUT WAVEFORMS

CCW Shaft Rotation as Viewed Looking at the Encoder Top

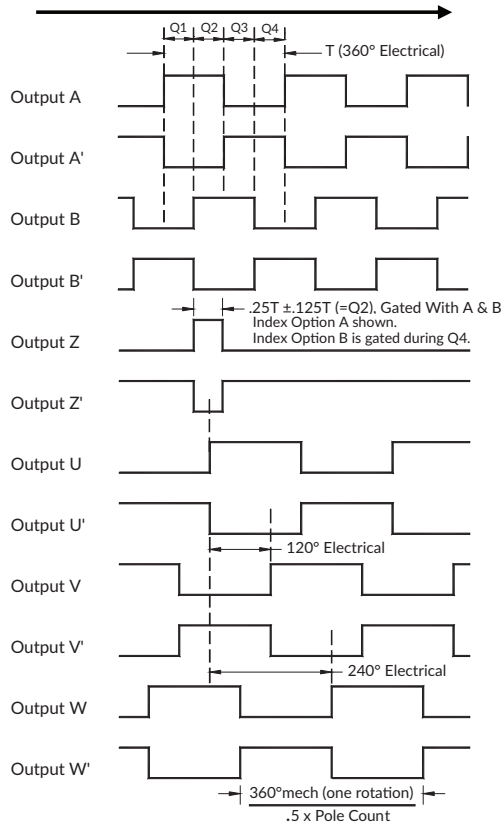

$$Q1 + Q2 = 0.5T \pm 0.125T$$

$$Q2 + Q3 = 0.5T \pm 0.125T$$

$$Qn = 0.25T \pm 0.125T \quad (n = 1, 2, 3, 4)$$

## ELECTRICAL SPECIFICATIONS

Input Voltage	5 VDC $\pm$ 5%						
Input Current Requirements	65 mA typical, 100 mA max plus interface loads						
Input Ripple	2% peak to peak @ 5 VDC						
Output Circuits	A = 26C31 line driver (RS-422 or single-ended TTL) B = ABZ 26C31 line driver, UVW open collector (no U' V' W') C = ABZ 26C31 line driver, UVW open collector (no U' V' W')						
Incremental Output Format	Quadrature with A leading B for CCW rotation viewed from the encoder top						
Max Operating Frequency	<ul style="list-style-type: none"> <li>&lt; 5000 PPR = 500 kHz or 15,000 RPM</li> <li>5000 PPR - 7999 PPR = 675 kHz</li> <li><math>\geq</math> 8000 PPR = 1.0 MHz</li> </ul>						
Commutation Format	Three phase 4, 6, 8 or 10 poles (other pole counts upon request)						
Commutation Accuracy (UVW)	$\pm 2^\circ$ mechanical						
Interpolation Factors	<table border="0"> <tr> <td>1000/1024 PPR = 2x</td> <td>2000/2048 PPR = 4x</td> </tr> <tr> <td>2500 PPR = 5x</td> <td>4000/4096 PPR = 8x</td> </tr> <tr> <td>5000/5120 PPR = 10x</td> <td>8000/8192 PPR = 16x</td> </tr> </table>	1000/1024 PPR = 2x	2000/2048 PPR = 4x	2500 PPR = 5x	4000/4096 PPR = 8x	5000/5120 PPR = 10x	8000/8192 PPR = 16x
1000/1024 PPR = 2x	2000/2048 PPR = 4x						
2500 PPR = 5x	4000/4096 PPR = 8x						
5000/5120 PPR = 10x	8000/8192 PPR = 16x						

## ENVIRONMENTAL SPECIFICATIONS

Storage Temperature	-40 to 125°C
Operating Temperature	-30 to 115°C
IP Rating	IP40
Humidity	90% non-condensing
Vibration	20 g's @ 25 to 2,000 Hz
Shock	100 g's @ 6 ms duration

## MECHANICAL SPECIFICATIONS

Bore Minimum Diameter	Bore size +0.0002"
Recommended Shaft Tolerance	+0.0000/-0.0005"
Minimum Shaft Engagement	0.400" [10.2 mm]
Allowable Shaft Runout	0.002" [0.05 mm] TIR ( $\pm 0.001$ " shaft radial play from initial shaft position of assembled encoder)
Allowable Axial Shaft Movement	$\pm 0.010$ " [ $\pm 0.25$ mm]
Mounting	A = 1.280" bolt circle/size 15 resolver, B = 1.812" bolt circle
Dynamic Commutation Adjustment Range	30° mechanical
Moment of Inertia	$8.0 \times 10^{-6}$ oz-in-s <sup>2</sup>

## ELECTRICAL PIN FUNCTIONS

Pin Number	Output Option		
	Option A	Option B	Option C
1	A	A	A
2	A'	A'	A'
3	B	B	B
4	B'	B'	B'
5	Z	Z	Z
6	Z'	Z'	Z'
7	U	U	U
8	U'	NC	GND2
9	V	V	V
10	V'	NC	Vcc2
11	W	W	W
12	W'	NC	NC
13	Vcc	Vcc	Vcc
14	GND	GND	GND
15	NC	NC	NC

Option C: Commutation power Vcc2 & GND2 are isolated from GND. U, V and W outputs are referenced to GND2. Vcc2 provides power to U, V and W internal pull up resistors (normally not installed) - call factory for this configuration.

## ELECTRICAL OUTPUT CIRCUITS

Output Option A, B & C: ABZ = 26C31 line driver (RS-422)

Output Option A: UVW = 26C31 line driver (RS-422)  
Output Option B: UVW = open collector  
Output Option C: UVW = open collector referenced to GND2

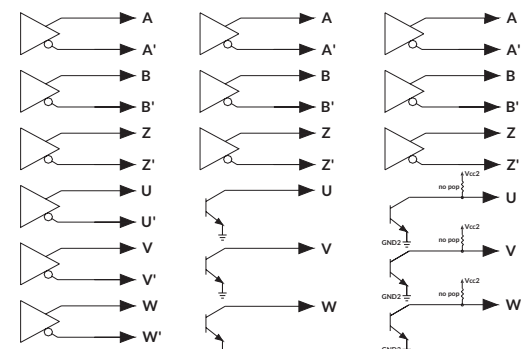

- 26C31 line driver is TTL compatible (can be wired single-ended)
- 26C31 sink/source 20mA max (meets RS-422 at 5 VDC supply)
- Open collector 30 mA sink max, pull up voltage 30 VDC max
- U, V and W are "no connect" for Commutation option 0

\*Quantum Devices, Inc. reserves the right to make changes in design, specifications and other information at any time without prior notice.

## MECHANICAL DIMENSIONS

Model QM35 – 1.280" Bolt Circle (Mounting Option A)

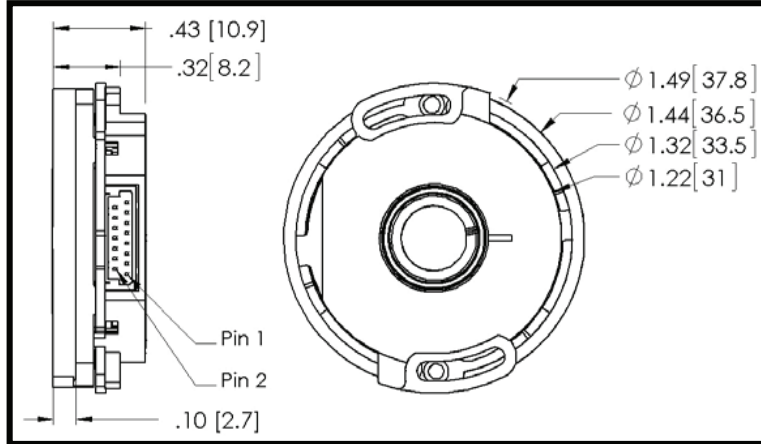

Model QM35 – 1.812" Bolt Circle (Mounting Option B)

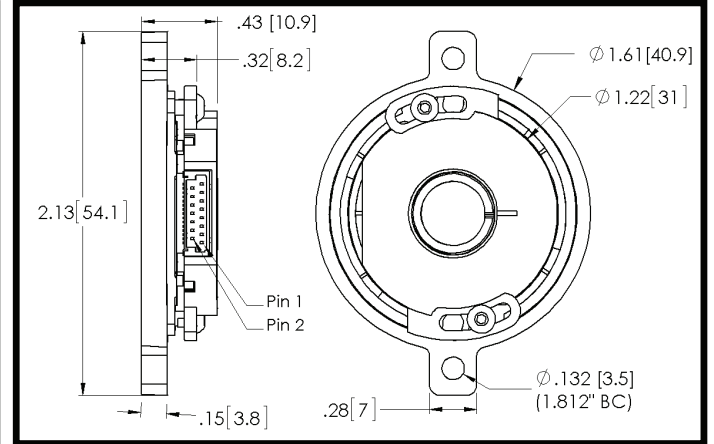

**Note:**

- Shown with Cover option A (hole in cover).
- Cover option B (closed) – Maximum shaft length up to 0.512" [13.0 mm]. Overall height increases from 0.43" [10.9 mm] to 0.57" [14.5 mm]. This additional height has a cylinder diameter 0.56" [14.2 mm], centered on the cover top.
- Cover option C (closed) – Maximum shaft length up to 0.450" [11.4 mm]. Overall height increases from 0.43" [10.9 mm] to 0.51" [13.0 mm]. This additional height has a cylinder diameter 0.56" [14.2 mm], centered on the cover top.

## MOUNTING REQUIREMENTS

Mounting Option A (1.280" Bolt Circle)

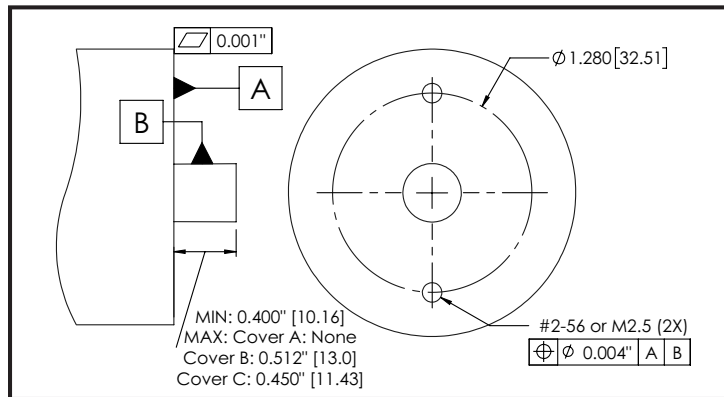

Mounting Option B (1.812" Bolt Circle)

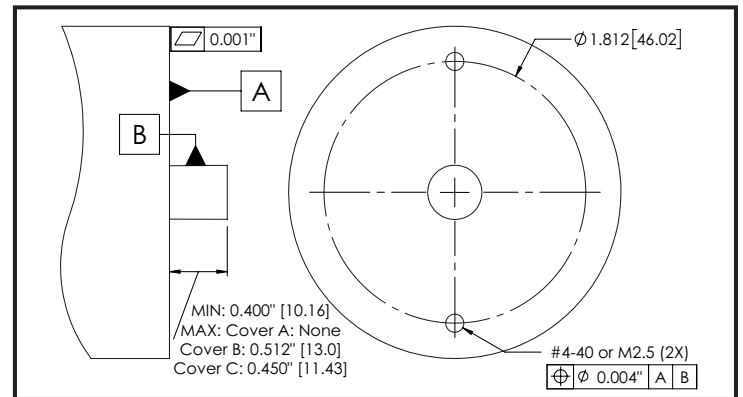

Servo Size 15 Mounting (Mounting Option A)

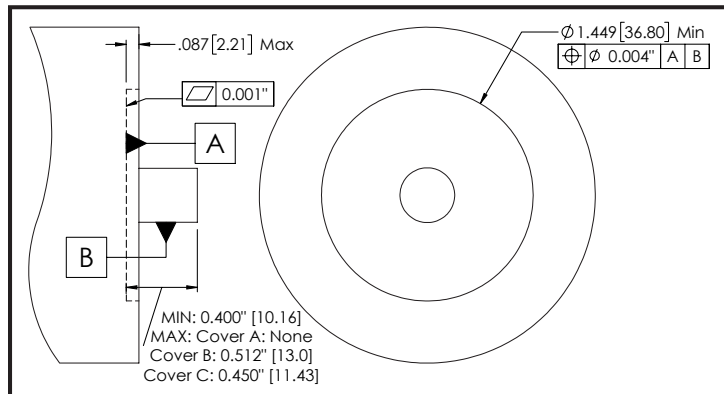

**Patent Protection:**

- US Patent 9,857,205
- US Patent 6,563,108

Sold & Serviced By:



Toll Free Phone (877) SERV098

[www.electromate.com](http://www.electromate.com)

[sales@electromate.com](mailto:sales@electromate.com)

\*Quantum Devices, Inc. reserves the right to make changes in design, specifications and other information at any time without prior notice.



**SELECTION CHARTS**

<b>MOUNTING OPTION A (1.280" BOLT CIRCLE)</b>							
#3-48 x 1/16" Set Screw 1/16" set screw required for 0.375" bore				#3-48 x 3/32" Set Screw 3/32" set screw has deeper hex pocket to improve assembly tool life			
Mounting Screws		Mounting Screws with Thread Lock		Mounting Screws		Mounting Screws with Thread Lock	
English	Metric	English	Metric	English	Metric	English	Metric
Option A	Option B	Option D	Option E	Option F	Option G	Option H	Option J

<b>MOUNTING OPTION B (1.812" BOLT CIRCLE)</b>							
#3-48 x 1/16" Set Screw 1/16" set screw required for 0.375" bore				#3-48 x 3/32" Set Screw 3/32" set screw has deeper hex pocket to improve assembly tool life			
Mounting Screws		Mounting Screws with Thread Lock		Mounting Screws		Mounting Screws with Thread Lock	
English	Metric	English	Metric	English	Metric	English	Metric
Option K	Option L	Option M	Option N	Option P	Option Q	Option R	Option S

Note:

- 1.) Bore Size option N (0.375") requires Hardware option A, B, D, E, K, L, M or N. This hardware can optionally be used with all other hub sizes.
- 2.) Hardware options F, G, H, J, P, Q, R and S have longer #3-48 set screws (3/32") and are not compatible with Bore Size option N (0.375").
- 3.) Hardware options D, E, H, J, M, N, R and S contain a thread lock which is applied to the mounting screws only. This preapplied thread locking product contains a microencapsulated epoxy resin that is suspended in a hardener. The force of thread engagement crushes the microscopic capsules of epoxy resin, mixing the reactant components, and initiating a chemical reaction which locks the parts together. This product series provides consistent and predictable torque values and requires no heat or primers for curing.  
Product - ND Industries 593S.

**HARDWARE SELECTION BREAKOUT**

	Option A	Option B	Option D	Option E	Option F	Option G	Option H	Option J
<b>Set Screws (Qty. 2 each)</b>	Black Ox #3-48 x 1/16" 0.050" Hex (Torque = 18 - 22 oz-in) Part Number 1829ZG014	Black Ox #3-48 x 1/16" 0.050" Hex (Torque = 18 - 22 oz-in) Part Number 1829ZG014	Black Ox #3-48 x 1/16" 0.050" Hex (Torque = 18 - 22 oz-in) Part Number 1829ZG014	Black Ox #3-48 x 1/16" 0.050" Hex (Torque = 18 - 22 oz-in) Part Number 1829ZG014	Black Ox #3-48 x 3/32" 0.050" Hex (Torque = 18 - 22 oz-in) Part Number 1829ZG015	Black Ox #3-48 x 3/32" 0.050" Hex (Torque = 28 - 32 oz-in) Part Number 1829ZG015	Black Ox #3-48 x 3/32" 0.050" Hex (Torque = 28 - 32 oz-in) Part Number 1829ZG015	Black Ox #3-48 x 3/32" 0.050" Hex (Torque = 28 - 32 oz-in) Part Number 1829ZG015
<b>Mounting Screws (Qty. 2 each)</b>	#2-56 x 1/4" Button Head, 0.050" Hex (Torque = 45 - 51 oz-in) Part Number 1834ZG002	M 2.5 x 6 mm Button Head (max dia. 4.5 mm) 1.5 mm Hex (Torque = 45 to 51 oz-in) Part Number 1834ZG050	#2-56 x 1/4" Button Head, 0.050" Hex with thread lock (Torque = 45 - 51 oz-in) Part Number 1834AG102	M 2.5 x 6 mm Button Head (max dia. 4.5 mm) 1.5 mm Hex with thread lock (Torque = 45 - 51 oz-in) Part Number 1834AG150	#2-56 x 1/4" Button Head, 0.050" Hex (Torque = 45 - 51 oz-in) Part Number 1834ZG002	M 2.5 x 6 mm Button Head (max dia. 4.5 mm) 1.5 mm Hex (Torque = 45 - 51 oz-in) Part Number 1834ZG050	#2-56 x 1/4" Button Head, 0.050" Hex with thread lock (Torque = 45 - 51 oz-in) Part Number 1834AG102	M 2.5 x 6 mm Button Head (max dia. 4.5 mm) 1.5 mm Hex with thread lock (Torque = 45 - 51 oz-in) Part Number 1834AG150
<b>Cover Screws (Qty. 2 each)</b>	Plastite 48-2, thread 2-28, length 1/4", Torx Plus IP7 (Torque = 37 - 43 oz-in) Part Number 1826ZG002	Plastite 48-2, thread 2-28, length 1/4", Torx Plus IP7 (Torque = 37 - 43 oz-in) Part Number 1826ZG002	Plastite 48-2, thread 2-28, length 1/4", Torx Plus IP7 (Torque = 37 - 43 oz-in) Part Number 1826ZG002	Plastite 48-2, thread 2-28, length 1/4", Torx Plus IP7 (Torque = 37 - 43 oz-in) Part Number 1826ZG002	Plastite 48-2, thread 2-28, length 1/4", Torx Plus IP7 (Torque = 37 - 43 oz-in) Part Number 1826ZG002	Plastite 48-2, thread 2-28, length 1/4", Torx Plus IP7 (Torque = 37 - 43 oz-in) Part Number 1826ZG002	Plastite 48-2, thread 2-28, length 1/4", Torx Plus IP7 (Torque = 37 - 43 oz-in) Part Number 1826ZG002	Plastite 48-2, thread 2-28, length 1/4", Torx Plus IP7 (Torque = 37 - 43 oz-in) Part Number 1826ZG002
	Option K	Option L	Option M	Option N	Option P	Option Q	Option R	Option S
<b>Set Screws (Qty. 2 each)</b>	Black Ox #3-48 x 1/16" 0.050" Hex (Torque = 18 - 22 oz-in) Part Number 1829ZG014	Black Ox #3-48 x 1/16" 0.050" Hex (Torque = 18 - 22 oz-in) Part Number 1829ZG014	Black Ox #3-48 x 1/16" 0.050" Hex (Torque = 18 - 22 oz-in) Part Number 1829ZG014	Black Ox #3-48 x 1/16" 0.050" Hex (Torque = 18 - 22 oz-in) Part Number 1829ZG014	Black Ox #3-48 x 3/32" 0.050" Hex (Torque = 18 - 22 oz-in) Part Number 1829ZG015	Black Ox #3-48 x 3/32" 0.050" Hex (Torque = 28 - 32 oz-in) Part Number 1829ZG015	Black Ox #3-48 x 3/32" 0.050" Hex (Torque = 28 - 32 oz-in) Part Number 1829ZG015	Black Ox #3-48 x 3/32" 0.050" Hex (Torque = 28 - 32 oz-in) Part Number 1829ZG015
<b>Mounting Screws (Qty. 2 each)</b>	#4-40 x 5/16" Button Head, 0.062" Hex (Torque = 45 - 51 oz-in) Part Number 1835ZG004	M 2.5 x 8 mm Button Head, 1.5 mm Hex (Torque = 45 - 51 oz-in) Part Number 1834ZG051	#4-40 x 5/16" Button Head, 0.062" Hex with thread lock (Torque = 45 - 51 oz-in) Part Number 1835ZG104	M 2.5 x 8 mm Button Head, 1.5 mm Hex with thread lock (Torque = 45 - 51 oz-in) Part Number 1834AG151	#4-40 x 5/16" Button Head, 0.062" Hex (Torque = 45 - 51 oz-in) Part Number 1835ZG004	M 2.5 x 8 mm Button Head, 1.5 mm Hex (Torque = 45 - 51 oz-in) Part Number 1834ZG051	#4-40 x 5/16" Button Head, 0.062" Hex with thread lock (Torque = 45 - 51 oz-in) Part Number 1835ZG104	M 2.5 x 8 mm Button Head, 1.5 mm Hex with thread lock (Torque = 45 - 51 oz-in) Part Number 1834AG151
<b>Cover Screws (Qty. 2 each)</b>	Plastite 48-2, thread 2-28, length 1/4", Torx Plus IP7 (Torque = 37 - 43 oz-in) Part Number 1826ZG002	Plastite 48-2, thread 2-28, length 1/4", Torx Plus IP7 (Torque = 37 - 43 oz-in) Part Number 1826ZG002	Plastite 48-2, thread 2-28, length 1/4", Torx Plus IP7 (Torque = 37 - 43 oz-in) Part Number 1826ZG002	Plastite 48-2, thread 2-28, length 1/4", Torx Plus IP7 (Torque = 37 - 43 oz-in) Part Number 1826ZG002	Plastite 48-2, thread 2-28, length 1/4", Torx Plus IP7 (Torque = 37 - 43 oz-in) Part Number 1826ZG002	Plastite 48-2, thread 2-28, length 1/4", Torx Plus IP7 (Torque = 37 - 43 oz-in) Part Number 1826ZG002	Plastite 48-2, thread 2-28, length 1/4", Torx Plus IP7 (Torque = 37 - 43 oz-in) Part Number 1826ZG002	Plastite 48-2, thread 2-28, length 1/4", Torx Plus IP7 (Torque = 37 - 43 oz-in) Part Number 1826ZG002

\*Quantum Devices, Inc. reserves the right to make changes in design, specifications and other information at any time without prior notice.

## CABLE ACCESSORIES

(2080AG039, 2082AG039, 2081AG019, 2083AG019)

Consult Factory for Custom Lengths

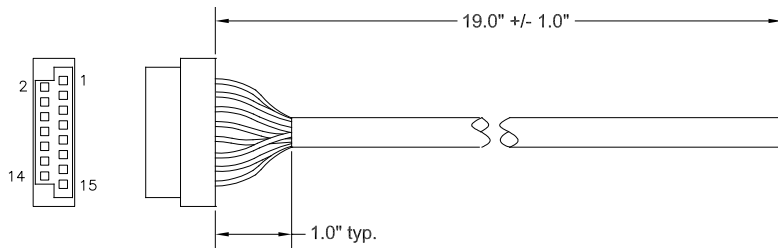
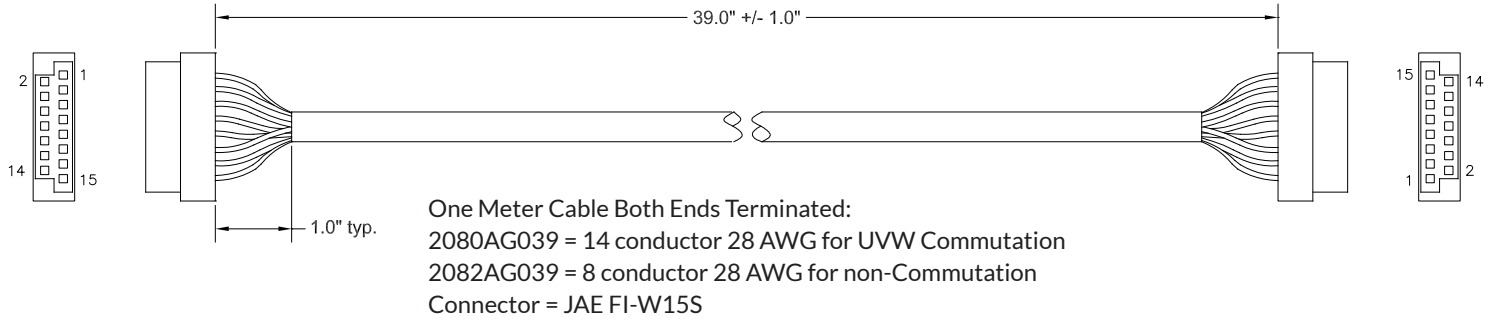

Half Meter Cable One End Terminated:  
 2081AG019 = 14 conductor 28 AWG for UVW Commutation  
 2083AG019 = 8 conductor 28 AWG for non-Commutation  
 Connector = JAE FI-W15S

Pin Number	Encoder Pin Function	2080AG039 2081AG019 Wire Color	2082AG039 2083AG019 Wire Color
1	A	Brown	Brown
2	A'	White	White
3	B	Blue	Blue
4	B'	Green	Green
5	Z	Orange	Orange
6	Z'	Yellow	Yellow
7	U	Violet	-
8	U'	Gray	-
9	V	White/Brown	-
10	V'	White/Red	-
11	W	White/Orange	-
12	W -	White/Yellow	-
13	Vcc	Red	Red
14	GND	Black	Black
15	No Connect	-	-

**Note:**

1. Cable has internal foil shield with 28 AWG drain wire trimmed to jacket edge
2. Unused wires to be locally isolated from adjacent signal wires, Vcc and GND to prevent damage to encoder signals
3. For Output option C, refer to Electrical Pin Function chart for signal function

Sold & Serviced By:



Toll Free Phone (877) SERV098

[www.electromate.com](http://www.electromate.com)

[sales@electromate.com](mailto:sales@electromate.com)