

POSITAL

FRABA

MANUAL IXARC KIT ENCODERS WITH SSI INTERFACE

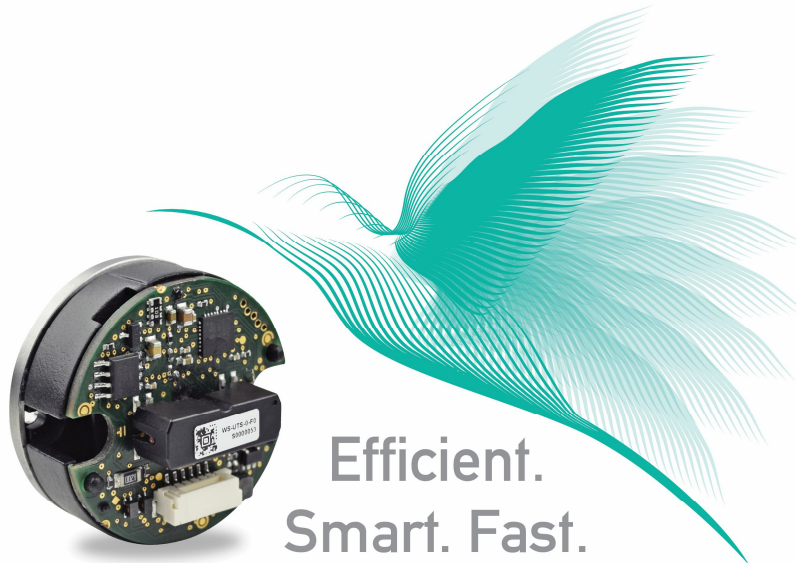

- Absolute singleturn and multiturn on one PCB
- Kit solution – no ball bearing, no tether, very compact: 36 mm diameter
- Digital serial interface: SSI
- Electrical resolution: Up to 17 bit singleturn and 32 bit multiturn
- Operating temperature:
-40 to +105 °C / -40 to 221 °F
- Very robust, insensitive to dust or humidity
- Easy installation, no manual alignment due to electronic calibration, relaxed mechanical tolerances
- In comparison to resolvers, full digital interface, no signal processing on motor controller required, no additional expensive voltage generator needed
- Additional functionality like electronic datasheet (EDS), up to 4 Kbyte OEM memory
- Integrated temperature sensor on board
- Kit design includes shielding concept against external fields e.g. from magnetic brake

Sold & Serviced By:



Canadian and International Sales

ELECTROMATE

877-737-8698

sales@electromate.com

www.electromate.com

U.S. Sales

SERVO2GO.com

877-378-0240

sales@servo2go.com

www.servo2go.com

POSITAL

FRABA

MANUAL

IXARC KIT ENCODERS WITH SSI INTERFACE

Contents

Contact	3
Safety	4
1. Introduction	5
2. Electrical Data	6
2.1 Connector.....	6
2.2 Electrical Characteristics.....	6
2.3 Communication Parameters.....	7
3. SSI Interface	8
3.1 Transmission Protocol.....	8
4. Configuration Interface (UBICOM)	10
4.1 Message Format.....	10
4.2 Read Register Command.....	10
4.3 Write Register Command.....	10
4.2 Checksum Calculation.....	11
5. Hardware and Software Features	13
5.1 Function Overview.....	13
5.2 Temperature Readout.....	14
5.3 Wiegand Sensor Test.....	15
5.4 Calibration.....	17
5.5 Data Storage.....	19
5.6 Filter Selection.....	21
5.7 Preset Function.....	23
6. Plug & Play via USB	26
7. References	27
8. Appendix	27
8.1 Register Overview.....	27
8.1.1 Direct Registers.....	27
8.1.2 Special Encoder Functions.....	28
8.1.3 Special Encoder Functions 2.....	29
8.1.4 EDS Encoder Data.....	29

POSITAL

FRABA

MANUAL

IXARC KIT ENCODERS WITH SSI INTERFACE

Release Note

Version Date: 06.03.2019

Version Number: 1.1

Authors: MLA, DKI

Reviewer: KMA, JST

Valid for

IXARC Encoder Kit Type: KCD-S101B-1617-XXXX-XXX

From firmware version 1.2.0

User Annotation

Please note, that no responsibility is assumed by POSITAL for any consequences arising out of the use of this material. This document is not intended as an instruction manual for untrained people.

POSITAL welcomes all readers to send us feedback and comments about this document.

Contact

FRABA America

T +1 609 750-8705

▶ info@posital.com

FRABA Europe

T +49 221 96213-0

▶ info@posital.eu

FRABA Asia

T +65 6514 8880

▶ info@posital.sg

© FRABA B.V., All rights reserved. The company FRABA B.V. claims copyright on this documentation. It is not allowed to modify, to extend, to hand over to a third party and to copy this documentation without written approval by the company FRABA B.V.. Nor is any liability assumed for damages resulting from the use of the information contained herein. Further, this publication and features described herein are subject to change without notice. We do not assume responsibility for technical inaccuracies or omissions. Specifications are subject to change without notice.

POSITAL

FRABA

MANUAL

IXARC KIT ENCODERS WITH SSI INTERFACE

Safety

- The encoder must be installed only by qualified personal, exhibiting the electric and mechanic knowledge.
- Implicitly consider the valid professional association safety and accident regulations for your country.
- Switch off the supply voltage of all devices connected to the encoder before installation.
- Implicitly avoid an electrical supply voltage during the connection of the encoder.
- Avoid shocks to motor shaft and mounting flange, that may cause mechanical damage of the encoder.
- Rotary machine shafts may cause injury, because these parts may catch hair and cloths.
- Mount the encoder in an ESD-conform fashion, avoid high voltages, e.g. caused by body discharge.
- The encoder and encoder housing must be free of metal chips and metallic dust.
- Implicitly consider the specifications of the encoder. The device must be operated in the specified range.

Sold & Serviced By:



Canadian and International Sales

ELECTROMATE

877-737-8698

sales@electromate.com

www.electromate.com

U.S. Sales

SERVO2GO.com

877-378-0240

sales@servo2go.com

www.servo2go.com

MANUAL

IXARC KIT ENCODERS WITH SSI INTERFACE

1. Introduction

With a combination of accuracy, reliability, robustness and cost efficiency POSITAL's magnetic kit encoders provide a unique variety of functionalities. An electrical resolution of up to 17 bit offers an accurate singleturn measurement. The multiturn range covers more than one million revolutions. A large temperature range between -40 °C and +105 °C makes the kit encoders applicable in lots of environmental conditions. The kit encoder components include an electronics package mounted on a compact 35 mm diameter PCB and a small permanent magnet, designed to be mounted on the end of a motor shaft. The electronics package includes four Hall sensors, a powerful 32-bit microprocessor and a rotation counter based on POSITAL's Wiegand energy harvesting system. The SSI interface enables a direct digital sensor data transmission.

The multiturn counting is realized by POSITAL's energy harvesting system, based on the Wiegand effect. At any revolution, a voltage pulse is generated, which triggers the increment of an internal multiturn counter. This Wiegand pulse counting requires no external energy source. Therefore, a backup battery or complex gear systems can be eliminated.

In contrast to optical encoders, the installation of POSITAL's magnetic kit encoders requires no clean room similar conditions and can be performed under normal factory conditions. The integrated electronic autocalibration function corrects position errors due to minor misalignments between motor shaft and electronics package and makes a manual alignment procedure obsolete. In addition, a software integrated Wiegand pulse test determines the performance of the multiturn counter system.

In this manual, an overview of our SSI kit encoder is presented. The electrical connection and characteristics of the device is provided in chapter 2. The integrated hardware and software features of the kit encoder are described in chapter 5.

MANUAL

IXARC KIT ENCODERS WITH SSI INTERFACE

2. Electrical Data

2.1 Connector

Connector Type: BM08B-GHS-TBT (JST)

Pin No.	Symbol	Description
1 (blue)	GND	Ground reference voltage
2 (rose)	Preset	Preset trigger
3 (gray)	Config	Configuration
4 (green)	Data +	SSI Data +
5 (yellow)	Data -	SSI Data -
6 (white)	CLK -	SSI Clock -
7 (brown)	CLK +	SSI Clock +
8 (red)	VCC	Supply Voltage with respect to GND

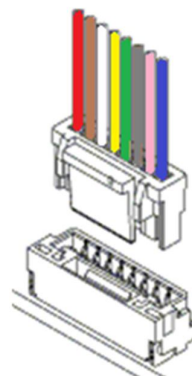

Table 1: Main Connector Allocation.

2.2 Electrical Characteristics

Item No.	Parameter	Sym- bol	Min.	Typ.	Max.	Unit	Remark
201	Supply Voltage	VCC	4.75	5.0	15	V	@25 °C, DC, other voltages possible on request.
202	Power Consumption	PC		0.3		W	
203	Reverse Polarity Protection				-15	V	

Table 2: Kit Encoder Electrical Characteristics.

POSITAL

FRABA

MANUAL

IXARC KIT ENCODERS WITH SSI INTERFACE

2.3 Communication Parameters

The communication parameters are listed below

Item No.	Parameter	Symbol	Min.	Typ.	Max.	Unit	Remark
301	Serial Communication Format	SSI					-
302	Output Driver	RS-422					-
303	SSI structure	Multiturn (MT) Singleturn (ST)			16 bit 17 bit		Default. MSB first
305	Clock Frequency	CF	200		1000	kHz	See Figure 2
306	Interface Cycle Time	CT	50			µs	-
307	SSI Timeout	Tout		6		µs	See Figure 2
308	Start phase			8		bits	See Figure 2

Table 3: SSI Communication Parameters.

Sold & Serviced By:



Canadian and International Sales

ELECTROMATE

877-737-8698

sales@electromate.com

www.electromate.com

U.S. Sales

SERVO2GO.com

877-378-0240

sales@servo2go.com

www.servo2go.com

MANUAL

IXARC KIT ENCODERS WITH SSI INTERFACE

3. SSI Interface

The SSI interface provides a communication connection between a master device, representing the motor control unit and its connected slave device, representing the kit encoder. The devices are connected in a point to point configuration, that only requires two unidirectional lines (clock and data) using differential signaling each. The slave device is synchronized by the clock signal, generated by the master. Therefore, it receives the transferred clocks and passes on its generated signal to the slave output line which is directly connected to the input line of the master (see Figure 1).

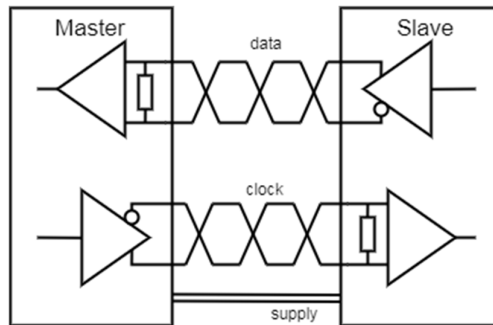

Figure 1: SSI interface.

3.1 Transmission Protocol

The communication between master and slave follows a defined pattern based on the SSI transmission frame (see Figure 2).

Transmission Frame

The SSI transmission frame is started and ended by the master clock signal (MA). The first falling edge of the MA latches the kit encoder position. With the first rising edge, the slave sets the data line to "0". The data line is "0" for the next 8 clocks. After this start phase the slave transmits the position data.

The position data consists of:

- Multiturn value (MT) 16 bit
- Singleturn value (ST) 17 bit

The MSB is transmitted first. The transmission frame ends with zeros.

POSITAL

FRABA

MANUAL

IXARC KIT ENCODERS WITH SSI INTERFACE

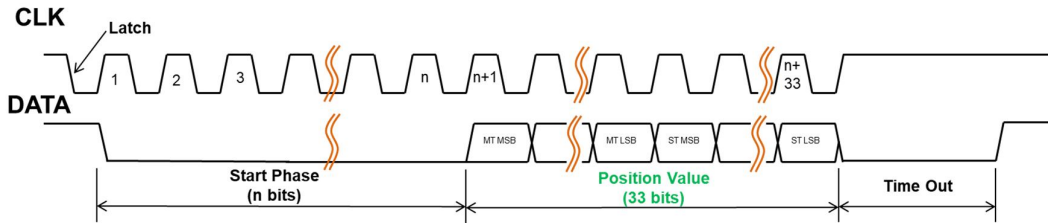

Figure 2: Protocol structure.

Sold & Serviced By:



Canadian and International Sales

ELECTROMATE

877-737-8698

sales@electromate.com

www.electromate.com

U.S. Sales

SERVO2GO.com

877-378-0240

sales@servo2go.com

www.servo2go.com

4. Configuration Interface (UBICOM)

All features are accessible via registers which can be addressed by using the configuration interface. The configuration interface uses a half-duplex UART communication. Table 4 shows the corresponding values. The next sections describes the protocol to read and write the registers.

4.1 Message Format

Due to the half-duplex transmission, the encoder only responds to requests (see Figure 3). The encoder starts to handle a request if the data line is quiet for least 2.3ms. Each packet consists of a header, payload and a checksum (see Table 5). The header contains a sync byte, an address, the command and the length of the packet. The payout content depends on the commands (see Table 4). Each frame ends with a checksum.

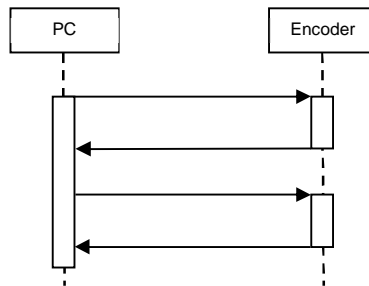

Figure 3: Communication cycle.

4.2 Read Register Command

To read an encoder register, the command with the number 0x01 has to be used. The payload consists of a 16 bit register address. The most significant byte of the address is transmitted first. The length of the payload is two (see Table 6). The next example shows the hole frame to read register 0x2E (content: current filter setting).

Example:

0x80+0x01+0x01+0x02+0x00+0x2E+0x4D

The encoder responds with: (if filter setting "V3" is active)

0x80+0x01+0x01+0x01+0x03+0x79

4.3 Write Register Command

To write an encoder register, the command with the number 0x02 has to be used. The payload consists of a 16 bit register address and 1 byte data. The most significant byte of the address is transmitted first. The length of the payload is three (see Table 7). The next example shows the hole frame to write the value 0x05 to register 0x2A (device mode register).

POSITAL

FRABA

MANUAL

IXARC KIT ENCODERS WITH SSI INTERFACE

Example:

0x80+0x01+0x02+0x03+0x00+0x2A+0x05+0x4A

The encoder responds with:

0x80+0x01+0x02+0x01+0x90+0xEB

Commands	Number	Payload length
Read register	0x00	0x02
Write register	0x01	0x03

Table 4: Commands.

4.2 Checksum Calculation

The encoder only responds on a correct checksum. The following example will show how to calculate the checksum for a read command on address 0x00. Each byte in the frame will be added and masked with 8 bit. At the end the sum has to be inverted.

Example:

$\text{NOT}(0x80+0x01+0x01+0x02+0x00+0x00) = \text{NOT}(0x84) = 0x7B$

Header				Payload	Checksum
Sync	Address	Command	Length of Payload		
0x80	0x01	<CMD>	<LEN>	<data0>... <dataN>	<chk>

Table 5: UART frame table.

Header				Payload	Checksum
Sync	Address	Command	Length of Payload		
0x80	0x01	0x01	0x02	<address>	<chk>

Table 6: Read command.

Header				Payload	Checksum
Sync	Address	Command	Length of Payload		
0x80	0x01	0x02	0x03	<address><data>	<chk>

Table 7: Write command.

POSITAL

FRABA

MANUAL

IXARC KIT ENCODERS WITH SSI INTERFACE

Item No.	Parameter	Symbol	Min.	Typ.	Max.	Unit	Remark
	Baud rate	BR		115200		Baud	
	Data format			8N1			8bit, no parity, 1 stop bit
	Voltage			3.3		V	
	Output current				15	mA	
	PC interface						Via Kit control box

Table 8: Configuration Interface Table.

Sold & Serviced By:



Canadian and International Sales

ELECTROMATE

877-737-8698

sales@electromate.com

www.electromate.com

U.S. Sales

SERVO2GO.com

877-378-0240

sales@servo2go.com

www.servo2go.com

MANUAL

IXARC KIT ENCODERS WITH SSI INTERFACE

5. Hardware and Software Features

5.1 Function Overview

The SSI kit encoder provides a set of additional features aside the actual angle measurement:

- Temperature Readout
- Wiegand Sensor Test
- Singleturn Calibration
- OEM Data Storage
- Filter Selection
- Electronic Datasheets
- Preset Function

The activation of a feature requires the activation of the corresponding device mode, except for the temperature readout. The change of the device mode is password secured. To enable the device mode configuration, the password "0x2A" must be written to register 0x2B. Next, the desired register value is written to the device mode register 0x2A.

Command Register	Register Address (direct)
Password register (password: 0x2A)	0x2B
Device mode register	0x2A

The following device modes are available:

Device Mode	Register Value
Operation mode	0x00
Calibration mode	0x01
Wiegand Sensor Test mode	0x02
OEM/EDS Motor Data Write	0x04
Filter Selection mode	0x05
Preset mode	0x07

Note

- All listed device features perform write cycles in the flash memory. Due to flash endurance, 1000 write cycles should not be exceeded.
- The device must be set back to operation mode, after carrying out a feature! The password register is not reset by changing the mode back to operation mode.

POSITAL

FRABA

MANUAL

IXARC KIT ENCODERS WITH SSI INTERFACE

5.2 Temperature Readout

The SSI kit encoder has an internal temperature sensor, used to monitor the encoder temperature. The measured temperature value T_{reg} is stored in the register 0x26. The register value T_{reg} can be converted to °C with equation

$$T[{}^{\circ}C] = T_{reg} - 50$$

and to °F with equation:

$$T[{}^{\circ}F] = 1.8 * T_{reg} + 32$$

The specifications of the integrated temperature sensor can be found in Table 9 . A change of the device mode is not necessary for this encoder feature.

Attention: The sensor measures the encoder temperature and is not intended to substitute a motor temperature sensor!

No.	Register Address	Value	OP	Remark
1	0x26	T_{reg}	R	Read out temperature register.

Parameter	Symbol	Remark
Interface	TSI	UART, size: 8 bit
Temperature Accuracy	TSA	5 °C
Temperature Range	TSR	-40 to 130 °C

Table 9: Temperature Sensor Properties.

Sold & Serviced By:



Canadian and International Sales

ELECTROMATE

877-737-8698

sales@electromate.com

www.electromate.com

U.S. Sales

SERVO2GO.com

877-378-0240

sales@servo2go.com

www.servo2go.com

POSITAL

FRABA

MANUAL

IXARC KIT ENCODERS WITH SSI INTERFACE

5.3 Wiegand Sensor Test

The SSI kit encoder uses a magnetic Wiegand counter to provide absolute multiturn values. The software integrated Wiegand sensor test measures the Wiegand sensor properties, by analyzing Wiegand pulses for 515 motor shaft revolutions. The test must be carried out for both clockwise (CW) and counter clockwise (CCW) rotations and can be performed by the following sequence. Carry out the sequence for CW first and afterwards for CCW direction.

No.	Register Address	Value	OP	Remark
1	-	-	-	Run the motor at constant rotation speed in CW direction. A rotation speed of 500-2000 rpm is recommended.
2	0x2B	0x2A	W	Enable device mode configuration: Write password 0x2A to register.
3	0x2A	0x02	W	Change device mode to Wiegand sensor test mode.
4	0x46	0x01	W	Start Wiegand sensor test, CW direction. The duration of the test routine depends on the rotation speed of the motor. The test must run for at least 515 motor revolutions.
5	0x47		R	Check the result of the test by reading the Wiegand sensor test status register. If the pulse collection in CW direction is active, the register value is 0x01. If the pulse collection in CW direction is finished, the routine waits for the change of motor direction to CCW (value 0x03).
6	-	-	-	Run the motor in CCW direction.
7	0x46	0x02	W	Start Wiegand sensor test, CCW direction.
8	0x47		R	Check the result of the test by reading the Wiegand sensor test status register. If the pulse collection in CCW direction is active, the register value is 0x04. If the pulse collection in CCW direction is finished, the test is completed (value 0x06).
9	0x46	0x05	W	(Optional) Save the acquired result data permanently. The saved data is not visible until an encoder reboot.
10	0x46	0x03	W	Finish test.
11	0x2A	0x00	W	Change device mode back to operation mode.

The saved result data can be checked at any time, if step 9 was executed. The average pulse height of the analyzed pulses and its standard deviation is saved for CW and CCW direction. A Wiegand pulse height average minus 4x standard deviation greater than 5.3 V is recommended for operation.

POSITAL

FRABA

MANUAL

IXARC KIT ENCODERS WITH SSI INTERFACE

Wiegand Sensor Test Status Register	Register Value
Test stopped	0x00
Pulse Collection active (CW)	0x01
Wait for change of motor rotation direction	0x03
Pulse Collection active (CCW)	0x04
Test complete	0x06
Test failed	0x07

Result Data (last test)	Register Address
Average Pulses (CW)	0x49
Average minus 4x Standard Deviation (CW)	0x4A
Average Pulses (CCW)	0x4B
Average minus 4x Standard Deviation (CCW)	0x4C

Result Data (saved)	Register Address
Average Pulses (CW)	0x51
Average minus 4x Standard Deviation (CW)	0x52
Average Pulses (CCW)	0x53
Average minus 4x Standard Deviation (CCW)	0x54

Note

- The result data values must be divided by 10 to get the value in volts.
- The Wiegand sensor test can be stopped at any time by writing value 0x03 to the pulse testing command register.
- The measured pulses are not depended on rotation speed, but low rotation speeds can lead to long test times.

Attention

- The encoder cannot be used as a feedback system during the test!
- It is highly recommended to run the Wiegand sensor test once after installation is finished.
- The encoder is not able to identify the rotation direction of the motor during the test, so make sure rotation and test direction match.

MANUAL

IXARC KIT ENCODERS WITH SSI INTERFACE

5.4 Calibration

The electronic calibration of the SSI encoder is required to improve the measurement accuracy of the kit encoder after installation.

The device is delivered in a pre-calibrated state. In factory state the accuracy of the encoder after installation is limited to an angle error below $\pm 0.3^\circ$ typically. This is caused by mechanical tolerances during the mounting of the kit encoder onto the motor shaft (static or build-up tolerances). By using the offered electronic calibration procedure, the impact of the static mounting tolerances on the kit encoder accuracy can be cancelled out and the system angle error will be improved towards the specified accuracy.

Please note, that after the electronic calibration further movements of the mounted magnet on the shaft towards the kit encoder (due to dynamic tolerances e.g. thermal expansion of the shaft or play of the ball bearing) should be minimized as these tolerances have a negative impact on the total system accuracy. To achieve the specified accuracy, it is recommended to keep the dynamic tolerance below ± 0.1 mm. The sum of static and dynamic tolerances must always be below ± 0.3 mm.

External Conditions for Calibration

To successfully calibrate the BiSS kit encoder several external conditions must be fulfilled. The sensor must be completely mounted (including housing for magnetic shielding) and fixed in the final position before the calibration is started. All external conditions should match the normal operation conditions as far as possible. The operating temperature of the kit encoder must be in the range of 25 °C to 40 °C (77 °F to 104 °F).

Calibration Register	Register Address
Command register	0x40
Status register	0x41

Calibration Status Register	Register Value
Calibration finished (CCW)	0x02
Calibration finished (CW)	0x22
Wrong rotation direction	0x30
Temperature out of range	0x31
Calibration failure	0x33

Calibration Procedure

The calibration of the fully mounted sensor requires a rotation of the motor shaft at constant speed of 500 rpm, where the deviation of the angular velocity should be less than 2 rpm.

Note, that the resulting angular accuracy is directly dependent on the rotation speed uniformity.

POSITAL

FRABA

MANUAL

IXARC KIT ENCODERS WITH SSI INTERFACE

The calibration procedure is performed by carrying out the following sequence:

No.	Register Address	Value	OP	Remark
1	-	-	-	Run the motor in CCW direction at constant rotation speed of 500 rpm \pm 2 rpm.
2	0x2B	0x2A	W	Unlock device mode configuration: Write password 0x2A to register.
3	0x2A	0x01	W	Change the device mode to calibration mode.
4	0x40	0x01	W	Start the calibration routine, CCW direction: Write value 0x01 to the calibration command register. The execution of the calibration routine takes about 5 seconds and stops automatically.
5	0x41		R	Read the calibration status until the register value is 0x02, then the calibration in CCW direction is finished. Note that while the encoder is performing the calibration, it may not respond.
6	-	-	-	Run the motor in CW direction.
7	0x40	0x02	W	Start the calibration routine, CW direction: Write value 0x02 to the calibration command register.
8	0x41		R	Read the calibration status register until the register value is 0x22, then the calibration in CW direction is finished. The calibration data is saved automatically.
9	0x2A	0x00	W	Change the device mode back to operation mode.

Note, that If calibration fails in CW direction the calibration table is lost, which leads to an increase of the angle error.

Attention: The encoder cannot be used as a feedback system during calibration!

Sold & Serviced By:



Canadian and International Sales

ELECTROMATE

877-737-8698

sales@electromate.com

www.electromate.com

U.S. Sales

SERVO2GO.com

877-378-0240

sales@servo2go.com

www.servo2go.com

POSITAL

FRABA

MANUAL

IXARC KIT ENCODERS WITH SSI INTERFACE

5.5 Data Storage

The SSI encoder offers the capability to access two different internal memory regions to store data: The EDS-Motor-Data and the OEM-Data. The corresponding memory addresses are given in table 2. The accessibility of the specific memory depends on the access rights.

Memory	Start-Addr.	End-Addr.	Access	Remark
EDS En-coder Data	0xC0	0x13F	R	We support the BiSS Profile 3 as Standard Encoder Profile.
EDS-Motor-Data	0x140	0x93F	R/W	2 Kbyte Motor Data: customer specific motor data
OEM-Data	0x940	0x113F	R/W	2 Kbyte OEM Memory: open access for customer use

Table 10: Data Storage Overview.

Writing the EDS-Motor-Data or OEM-Data is permitted by default. The write access is protected by a password. To write an EDS-Motor or OEM-Data register, carry out the following sequence:

No.	Register Address	Value	OP	Remark
1	0x2B	0x2A	W	Unlock device mode configuration: Write password 0x2A to register.
2	0x2A	0x04	W	Change the device mode to OEM / EDS Motor Data Write.
3	0x5B		R	Get write access: Read OEM / EDS-Motor Data Write status register until a value of 0x00 indicates permission to get write access to the EDS-Motor Data.
4	0x5A	0x01 or 0x02	W	Write the value to the OEM / EDS-Motor Data Write command register. 0x01: access EDS-Motor Data 0x02: access OEM-Data
5			W	Write data to the desired register, by using the BiSS register communication.
6	0x5B		R	Get save access: Read the OEM / EDS-Motor Data Write status register until a value of 0x01 indicates permission to get save access to the EDS-Motor Data.
7	0x5A	0x03	W	Write data to flash memory: Write the value 0x03 to the OEM / EDS-Motor Data Write command register
8	0x5A	0x04	W	(Optional) Cancel write access: Write the value 0x04 to the OEM / EDS-Motor Data Write command register.
9	0x2A	0x00	W	Change the device mode back to operation mode.

POSITAL

FRABA

MANUAL

IXARC KIT ENCODERS WITH SSI INTERFACE

OEM / EDS-Motor Data Register	Register Address
Command register	0x5A
Status register	0x5B

OEM / EDS-Motor Data Command	Register Value
Get write access EDS-Motor Data	0x01
Get write access OEM-Data	0x02
Save data	0x03
Cancel write access	0x04

OEM / EDS-Motor Data Status Register	Register Value
Wait for write access	0x00
Wait for save command	0x01

Attention: Reading and writing data during motor operation is not allowed.

Sold & Serviced By:



Canadian and International Sales

ELECTROMATE

877-737-8698

sales@electromate.com

www.electromate.com

U.S. Sales

SERVO2GO.com

877-378-0240

sales@servo2go.com

www.servo2go.com

POSITAL

FRABA

MANUAL

IXARC KIT ENCODERS WITH SSI INTERFACE

5.6 Filter Selection

The SSI encoder offers two different filter options:

- **Balanced (default)**

This filter provides a very well-balanced relation of signal noise and dynamic behavior.

- **Dynamic**

This filter provides position values with short latency, but increased signal noise. Therefore, this filter is suitable for very fast and dynamic motor control loops.

To check which filter is currently active, read direct register 0x6E (balanced: 0x03, dynamic: 0x04). To activate a filter setting, carry out the following sequence:

No.	Register Address	Value	OP	Remark
1	0x2B		W	Enable device mode configuration: Write password 0x2A to register.
2	0x2A	0x05	W	Change device mode to filter selection mode.
3	0x65		R	Get write access: Read filter status register. A value of 0x00 indicates permission to get write access.
4	0x64	0x01	W	Write value 0x01 to the filter command register.
5	0x65		R	Read filter status register. A value of 0x02 indicates waiting for value.
6	0x64		W	Set filter: <ul style="list-style-type: none"> ▪ Balanced filter, value 0x03 ▪ Dynamic filter, value 0x04
7	0x65		R	Save filter selection: Read filter status register. A value of 0x01 indicates permission to save filter settings.
8	0x64	0x02	W	Write value to filter command register. Encoder reboots with new filter setting.
9	0x2A	0x00	W	Change the device mode back to operation mode.

Filter Selection Register	Register Address
Command register	0x64
Status register	0x65

POSITAL

FRABA

MANUAL

IXARC KIT ENCODERS WITH SSI INTERFACE

Commands	Register Value
Get write access	0x01
Save filter selection	0x02
Balanced filter	0x03
Dynamic filter	0x04

Attention: The encoder cannot be used as a feedback system during the filter change!

Note, that the filter selection feature is only supported from firmware version 1.1.0.

Sold & Serviced By:



Canadian and International Sales

ELECTROMATE

877-737-8698

sales@electromate.com

www.electromate.com

U.S. Sales

SERVO2GO.com

877-378-0240

sales@servo2go.com

www.servo2go.com

POSITAL

FRABA

MANUAL

IXARC KIT ENCODERS WITH SSI INTERFACE

5.7 Preset Function

The preset function can be used to adapt the encoder position to the mechanical alignment of the system. By performing a preset, the actual position value of the encoder (both, singleturn and multiturn) is set to the desired preset value. The preset value is specified in registers 0x82 to 0x87. In registers 0x82 to 0x84 the singleturn preset value is saved in little-endian format. In registers 0x85 to 0x87 the multiturn preset value is saved in little-endian format. The preset can be triggered via hardware or software.

Preset Value	Singleturn preset value			Multiturn preset value		
Register Address	0x82	0x83	0x84	0x85	0x86	0x87
Endianness	LSB		MSB	LSB		MSB

Table 11: Preset value register.

Hardware preset

To perform a preset via hardware, the voltage level at the preset pin has to be pulled to V_{preset} and hold for at least $t_{\text{min}} = 100 \text{ ms}$ (see Table 12, see Figure 4). The manufacturer default value is 0. After t_{min} the preset value is overtaken independent of a longer high level on the input channel and the kit encoder is conducting a reset.

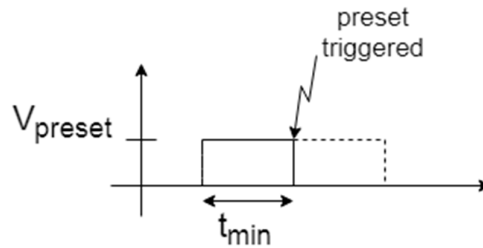

Figure 4: Preset hardware trigger.

Software preset

To change the preset value and perform a preset via software, follow the steps below:

No.	Register Address	Value	OP	Remark
1	0x2B	0x2A	W	Enable device mode configuration: Write password 0x2A to register.
2	0x2A	0x07	W	Change device mode to preset mode. If no change of the preset value is desired, proceed with step 9.
3	0x80	0x02	W	Enable preset value edit , to set target preset value.
4	0x81		R	Read status register, a value of 0x01 indicates waiting for value to enter.
5	0x82 – 0x84		W	Enter singleturn preset value.
6	0x85 – 0x87		W	Enter multiturn preset value.

POSITAL

FRABA

MANUAL

IXARC KIT ENCODERS WITH SSI INTERFACE

7	0x80	0x03	W	Save preset value. Encoder restarts.
8				Repeat steps 1, 2, 3 to enter preset mode again.
9	0x80	0x01	W	Perform preset. Encoder restarts with preset value.
10	0x2A	0x00	W	Change the device mode back to operation mode.

Example

Assuming it is desired to preset the singleturn position of a kit encoder with 17 bit singleturn resolution.

Desired singleturn position: 270°
 Corresponding decimal value in digits: 98304
 Expressed as a hex value: 0x18000

For this configuration, the register entries must be set as followed:

Register Address	0x82	0x83	0x84
Register Value	0x00	0x80	0x01

Preset Register	Register Address
Command register	0x80
Status register	0x81
Singleturn preset value	0x82 – 0x84
Multiturn preset value	0x85 – 0x87

Commands	Register Value
Perform preset	0x01
Enable preset value edit	0x02
Save preset value	0x03

Note, that the preset function is only supported with KCD-BC01B-1617-XXXX-XXX from firmware version 1.2.0.

POSITAL

FRABA

MANUAL

IXARC KIT ENCODERS WITH SSI INTERFACE

Item No.	Parameter	Symbol	Min.	Typ.	Max.	Unit	Remark
401	Preset voltage	V_{preset}	3.3		VCC	V	-
402	Preset low voltage level				1.2	V	-
403	Preset hold time	t_{min}	100			ms	-
404	Preset value			0			MT+ST

Table 12: Preset parameter table.

Sold & Serviced By:



Canadian and International Sales

ELECTROMATE

877-737-8698

sales@electromate.com

www.electromate.com

U.S. Sales

SERVO2GO.com

877-378-0240

sales@servo2go.com

www.servo2go.com

MANUAL

IXARC KIT ENCODERS WITH SSI INTERFACE

6. Plug & Play via USB

For easy commissioning there is the option to connect the encoder to a PC and access, configure or calibrate the encoder.

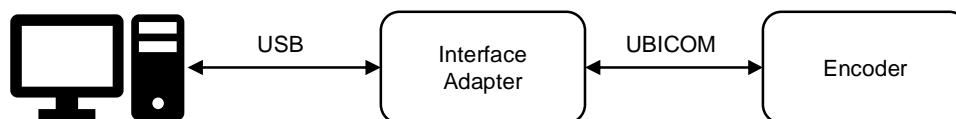

Figure 5: Connection of interface adapter.

Kit Control Box

Using UBICOM for communication

- Access position and register data
- Software GUI to run the main kit encoder functions
- Easy way to perform calibration, preset, Wiegand sensor test and configure filter settings
- Readout encoder temperature and firmware version
- Alternatively program your own encoder related requests based on the UBICOM protocol

▶ VIDEO INSTRUCTION



Figure 6: Kit Control Box and software GUI by POSITAL.

For more details see:

<https://www.posita.com/en/products/kit-encoders/kit-control-box.php>

MANUAL

IXARC KIT ENCODERS WITH SSI INTERFACE

7. References

8. Appendix

8.1 Register Overview

8.1.1 Direct Registers

Register Address	Description / Symbol	Access	Default Value
0x04	Serial Number, U32	R	-
0x05		R	-
0x06		R	-
0x07		R	-
0x26	Temperature Intern	R	-
0x28	Fault Register	R	-
0x29	Warning Register	R	-
0x2A	Device Mode	R/W	0x00
0x2B	Protection	R/W	0x00
0x2E	Selected Filter	R	0x03
0x34	Major Firmware Release	R	-
0x35	Minor Firmware Release	R	-
0x36	Firmware Patch Level	R	-
0x38	Device ID	R	0x01
0x39		R	0x02
0x3A		R	0x10
0x3B		R	0x11
0x3C		R	0x00
0x3D		R	0x01
0x3E	Manufacturer Coder	R	0x46
0x3F		R	0x72

Table 13: Direct Registers.

POSITAL

FRABA

MANUAL

IXARC KIT ENCODERS WITH SSI INTERFACE

8.1.2 Special Encoder Functions

Register Address	Description / Symbol	Access	Default Value
0x40	Calibration Command	R/W	0x00
0x41	Calibration Status	R	0x00
0x46	Wiegand Sensor Test, Command Register	R/W	0x00
0x47	Wiegand Sensor Test, Status Register	R	0x00
0x48	Wiegand Sensor Test, Error Code	R	0x00
0x49	Wiegand Sensor Test, Average Pulses CW (last test result)	R	0x00
0x4A	Wiegand Sensor Test, Average minus 4x Standard Deviation CW (last test result)	R	0x00
0x4B	Wiegand Sensor Test, Average Pulses CCW (last test result)	R	0x00
0x4C	Wiegand Sensor Test, Average minus 4x Standard Deviation CCW (last test result)	R	0x00
0x4D	Wiegand Sensor Test, Average Pulses CW (FRABA Production)	R	-
0x4E	Wiegand Sensor Test, Average minus 4x Standard Deviation CW (FRABA Production)	R	-
0x4F	Wiegand Sensor Test, Average Pulses CCW (FRABA Production)	R	-
0x50	Wiegand Sensor Test, Average minus 4x Standard Deviation CCW (FRABA Production)	R	-
0x51	Wiegand Sensor Test, Average Pulses CW (saved test result)	R	-
0x52	Wiegand Sensor Test, Average minus 4x Standard Deviation CW (saved test result)	R	-
0x53	Wiegand Sensor Test, Average Pulses CCW (saved test result)	R	-
0x54	Wiegand Sensor Test, Average minus 4x Standard Deviation CCW (saved test result)	R	-

MANUAL

IXARC KIT ENCODERS WITH SSI INTERFACE

0x5A	OEM / EDS-Motor Data Write, Command Register	R/W	-
0x5B	OEM / EDS-Motor Data Write, Status Register	R	-
0x64	Filter Selection, Command Register	R/W	-
0x65	Filter Selection, Status Register	R	-

Table 14: Special Encoder Functions.

8.1.3 Special Encoder Functions 2

Register Address	Description / Symbol	Access	Default Value
0x80	Preset Command	R/W	0x00
0x81	Preset Status	R	0x00
0x82	Preset singleturn value, byte 0	R/W	0x00
0x83	Preset singleturn value, byte 1	R/W	0x00
0x84	Preset singleturn value, byte 2	R/W	0x00
0x85	Preset multiturn value, byte 0	R/W	0x00
0x86	Preset multiturn value, byte 1	R/W	0x00
0x87	Preset multiturn value, byte 2	R/W	0x00

Table 15: Special Encoder Functions 2.

8.1.4 EDS Encoder Data

Register Address	Description / Symbol	Access	Default Value
0x106	Maximum "power on delay" until position data is available	R	0xFF
0x108	Encoder Type	R	0x00
0x10A	Data Length MULTITURN	R	0x10
0x10C	Data Length COARSE	R	0x11
0x12C	Maximum revolution speed/maximum speed [1/min]	R	0x2E
0x12D		R	0xE0
0x130	Minimum operating temperature [K]	R	0x00
0x131		R	0xE9
0x132	Maximum operating temperature [K]	R	0x01
0x133		R	0x7A

POSITAL

FRABA

MANUAL

IXARC KIT ENCODERS WITH SSI INTERFACE

0x134	Minimum operating voltage [mV]	R	0x13
0x135		R	0x88
0x136	Maximum operating voltage [mV]	R	0x2E
0x137		R	0xE0
0x138	Maximum current consumption [mA]	R	0x00
0x139		R	0x46

Table 16: Bank 3 / Electronic Data Sheet, Encoder Data.

Sold & Serviced By:



Canadian and International Sales

ELECTROMATE

877-737-8698

sales@electromate.com

www.electromate.com

U.S. Sales

SERVO2GO.com

877-378-0240

sales@servo2go.com

www.servo2go.com