

POSITAL

FRABA

DATASHEET

KCD-BC03B-XX17-XXXX-XXX

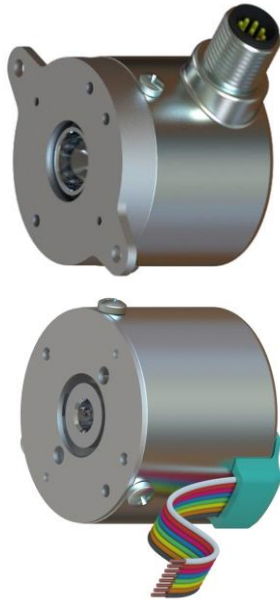

IXARC Multiturn Kit Encoder With BiSS C Interface

- ▶ Kit Encoder for Integration to Motors, Robots and Machinery ¹
- ▶ Mechanically Compatible to Common Broadcom and US Digital Kit Encoders²
- ▶ Electrical Resolution: Up To 17 bit
- ▶ Multiturn Range: Up To 32 Bit
- ▶ 37 mm Diameter
- ▶ Energy-Harvesting-System Based On Wiegand Effect
- ▶ No Battery – No Maintenance
- ▶ Easy Installation

1. Interface

Interface	BiSS C
Programming Functions	Electronic Calibration, Wiegand Sensor Test, Preset
Min Interface Cycle Time	50 μ s

2. Electrical Data

Supply Voltage	4.75-15 VDC
Power Consumption	\leq 0.3 Watt
Start-up time	max 100 ms
Clock Input	RS 422
Clock Frequency	80 kHz - 10 MHz
Reverse Polarity Protection	Yes
Short Circuit Protection	Yes
MTTF	20 years @105 °C (221 °F)
Max. Permissible Electrical Speed	12.000 RPM

¹ The use of these kit encoders for the production of industrial rotary encoders is prohibited. Applications in rotary encoders are protected by several worldwide patents (such as WO 2004/046735 A1) and require licensing.

² See separate cross reference documents.

POSITAL

FRABA

DATASHEET

KCD-BC03B-XX17-XXXX-XXX

3. Sensor

Singleturn Technology	Magnetic
Electrical Resolution Singleturn	17 bit ³
Multiturn Technology	Self powered magnetic pulse counter (no battery, no gear)
Multiturn Range	16 bit ³
Accuracy (INL)	≤ ±0.3 Degrees ⁴
Increasing Counting Direction (Default)	Clockwise shaft rotation (front view on shaft)

4. Environmental Specifications

Protection Class	IP30 - JAQ With Cable Clip Installed and PRQ IP20 – JAQ Without Cable Clip Installed
Operating Temperature	-40 °C (-40 °F) – +105 °C (221 °F)
Shock Resistance	≤ 200 g (half sine 6 ms, EN 60068-2-27)
Permanent Shock Resistance	≤ 20 g (half sine 16 ms, EN 60068-2-29)
Vibration Resistance	≤ 20 g (10 Hz – 1000 Hz, EN 60068-2-6)

5. Mechanical Data

Housing Material	Steel
Housing Coating	Cathodic corrosion protection
Flange Material	Aluminum
Shaft Material	Stainless Steel

³ Please contact Posital for other resolutions and multiturn ranges.







⁴ Magnetic Rotor Assembled TIR ≤ ±0.15mm [0.006"]. INL error can further be reduced using in system calibration if required, contact Posital for more information.

POSITAL

FRABA

DATASHEET
KCD-BC03B-XX17-XXXX-XXX

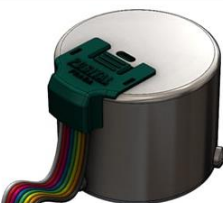
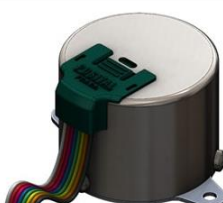
6. Versions

	E5/E6	E7	F5	F7
	x = Available hub sizes: 4, 5, 6, R (1/4")		X = Available hub sizes: 8, A (10), S (3/8")	
U PRQ	 E5xU/E6xU	 E7xU	 F5xU	 F7xU
W JAQ	 E5xW/E6xW	 E7xW	 F5xW	 F7xW

7. Electrical Connection

Connection Orientation	JAQ - Axial	PRQ -Radial
Connector	JST BM08B-GHS-TBT	8 pin M12, a-coded, male

8. Connection Plan

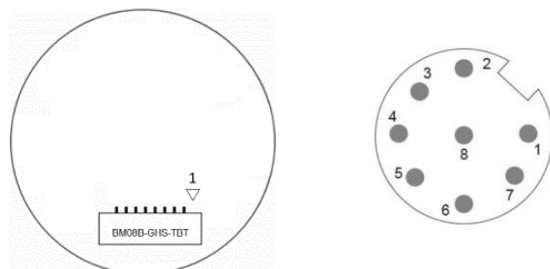

Signal	JAQ Pin	PRQ Pin
GND	1	1
Preset (Default 0 position value)	2	7
Config (Kit control box, serial communication)	3	8
Data+ (SLO+)	4	5
Data- (SLO-)	5	6
CLK- (MA-)	6	4
CLK+ (MA+)	7	3
Power (Vs)	8	2

POSITAL

FRABA

DATASHEET

KCD-BC03B-XX17-XXXX-XXX

9. Dimensional Drawings⁵

E5xW-JAQ: d = Ø4mm, Ø5mm, Ø6mm or Ø1/4"

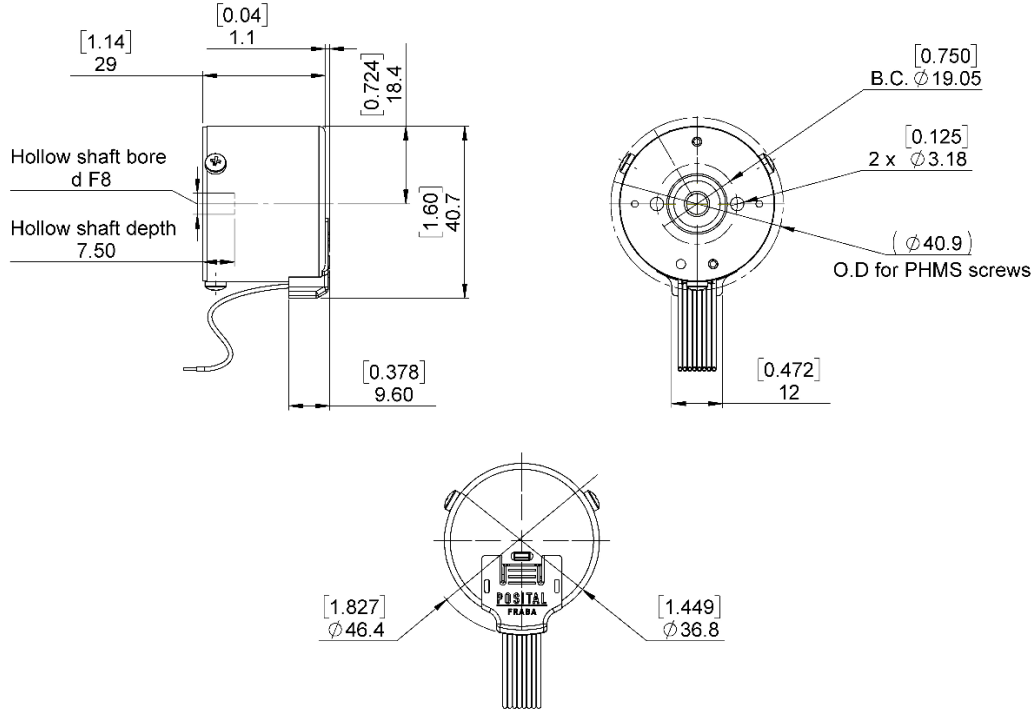

E5xU-PRQ: d = Ø4mm, Ø5mm, Ø6mm or Ø1/4"

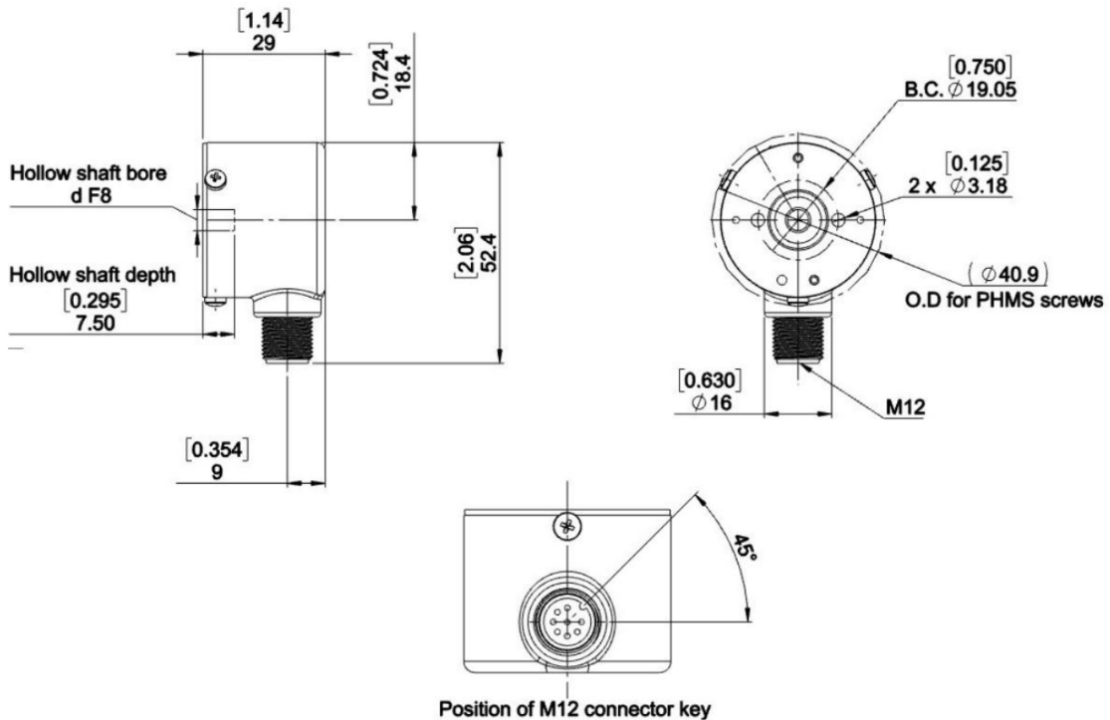

⁵All dimension in mm [Inches]. This drawing and the information contained within is for general presentation purposes only. Please refer to the "Download" section for detailed technical drawing.

POSITAL

FRABA

DATASHEET

KCD-BC03B-XX17-XXXX-XXX

E6xW-JAQ: d = Ø4mm, Ø5mm, Ø6mm or Ø1/4"

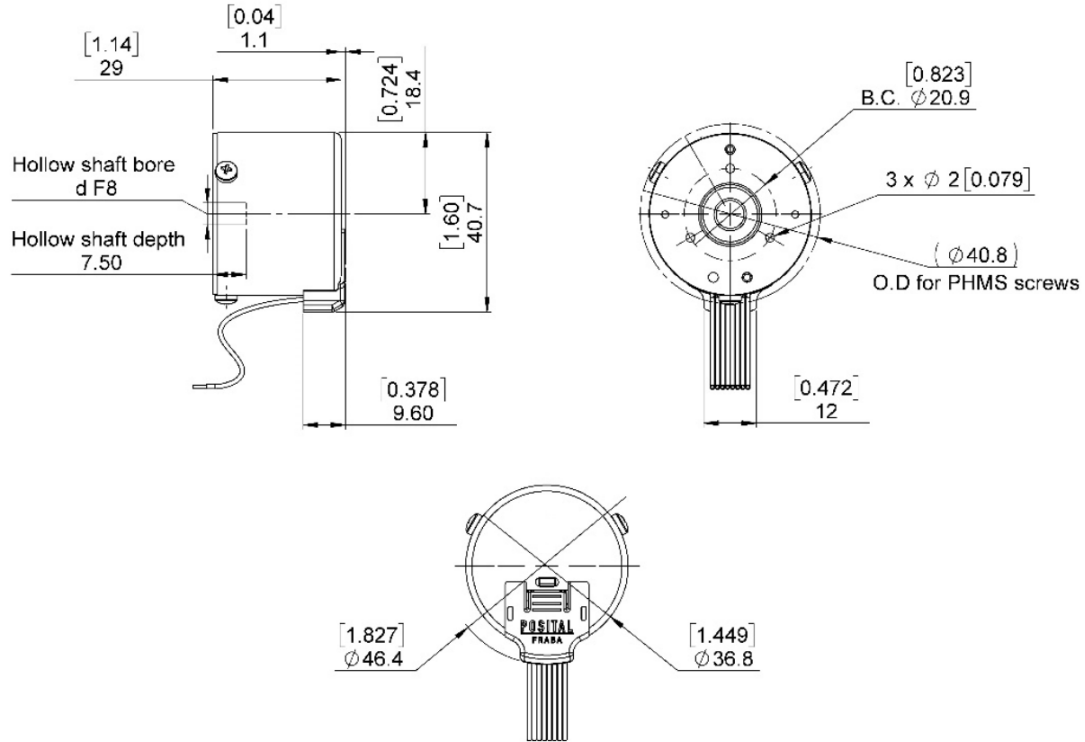

E6xU-PRQ: d = Ø4mm, Ø5mm, Ø6mm or Ø1/4"

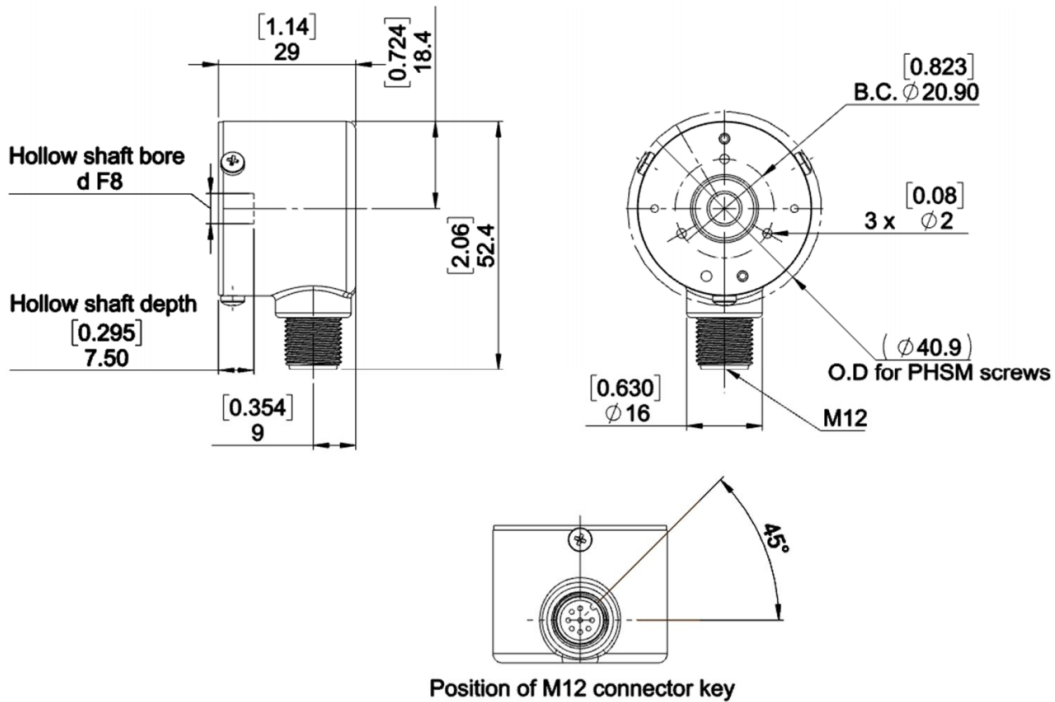

POSITAL

FRABA

DATASHEET

KCD-BC03B-XX17-XXXX-XXX

E7xW-JAQ: d = Ø4mm, Ø5mm, Ø6mm or Ø1/4"

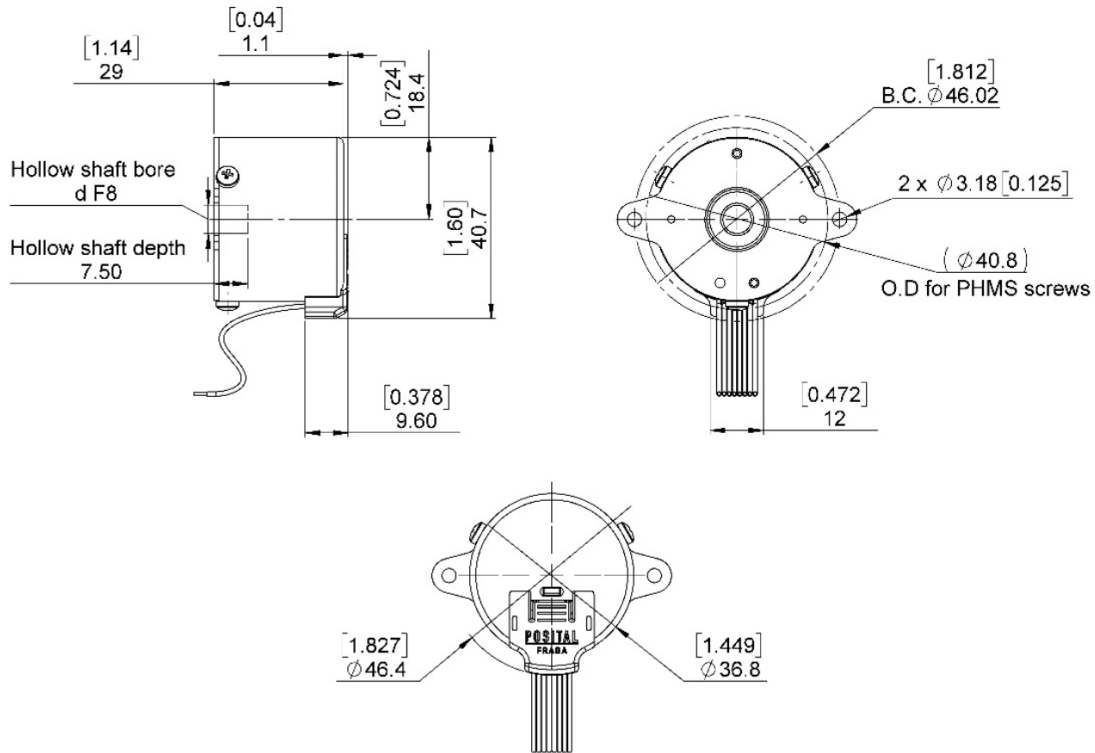

E7xU-PRQ: d = Ø4mm, Ø5mm, Ø6mm or Ø1/4"

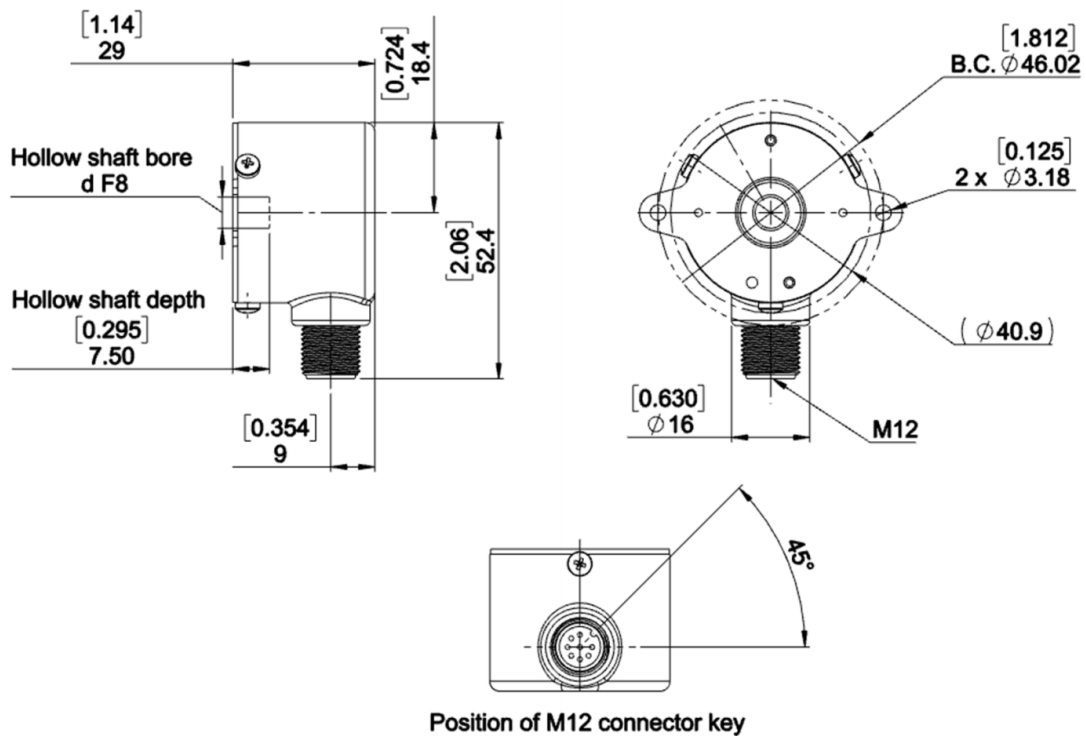

POSITAL

FRABA

DATASHEET

KCD-BC03B-XX17-XXXX-XXX

F7xW-JAQ: d = Ø8mm, Ø10mm or Ø3/8"

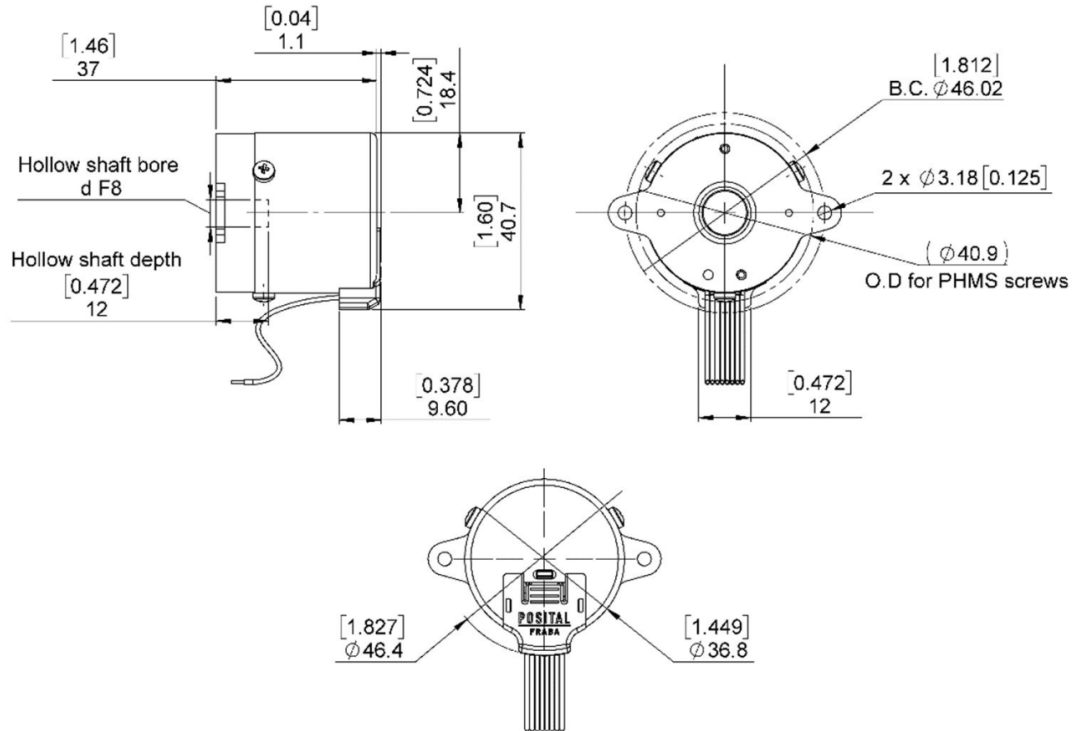

F7xU-PRQ: d = Ø8mm, Ø10mm or Ø3/8"

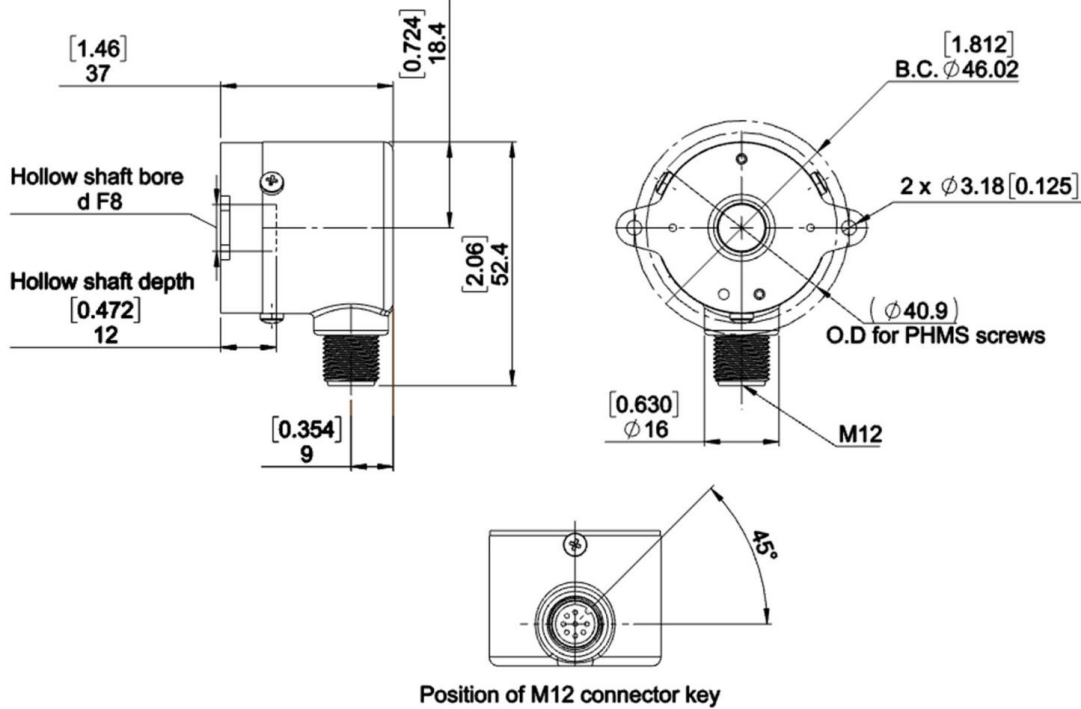

POSITAL

FRABA

DATASHEET
KCD-BC03B-XX17-XXXX-XXX

10. Mounting Requirements

E5/F5

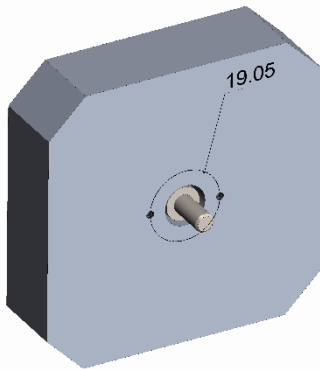

Motor Flange:

2x #2-56 UNC, #4-40 UNC or M2.5

Shaft:

E5
∅ 4 mm h7 x 6.5 mm (+/-0.5mm)
∅ 5 mm h7 x 6.5 mm (+/-0.5mm)
∅ 6 mm h7 x 6.5 mm (+/-0.5mm)
∅ 1/4 inch h7 x 6.5 mm (+/-0.5mm)
F5
∅ 8 mm h7 x 11 mm (+/-0.5mm)
∅ 10 mm h7 x 11 mm (+/-0.5mm)
∅ 3/8 inch h7 x 11 mm (+/-0.5mm)

E6

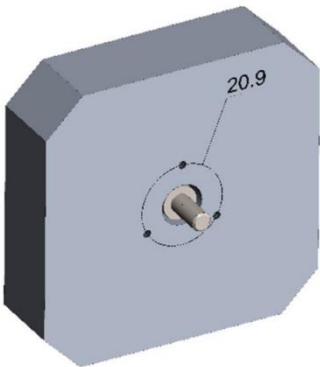

Motor Flange:

3x #0-80 UNC or M1.6

Shaft:

∅ 4 mm h7 x 6.5 mm (+/-0.5mm)
∅ 5 mm h7 x 6.5 mm (+/-0.5mm)
∅ 6 mm h7 x 6.5 mm (+/-0.5mm)
∅ 1/4 inch h7 x 6.5 mm (+/-0.5mm)

E7/F7

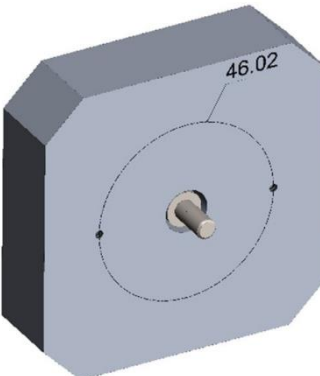

Motor Flange:

2x #2-56 UNC, #4-40 UNC or M2.5

Shaft:

E7
∅ 4 mm h7 x 6.5 mm (+/-0.5mm)
∅ 5 mm h7 x 6.5 mm (+/-0.5mm)
∅ 6 mm h7 x 6.5 mm (+/-0.5mm)
∅ 1/4 inch h7 x 6.5 mm (+/-0.5mm)
F7
∅ 8 mm h7 x 11 mm (+/-0.5mm)
∅ 10 mm h7 x 11 mm (+/-0.5mm)
∅ 3/8 inch h7 x 11 mm (+/-0.5mm)

POSITAL

FRABA

DATASHEET

KCD-BC03B-XX17-XXXX-XXX

11. Version Space / Ordering Code

Description	Ordering Code				
	KCD- BC03B-	XX	XX-	XXX	X-XXX
MT Range (Bits)	Single-Turn	00			
	Multi-Turn (16,384 Revolutions)	16			
ST Resolution (Bits)	131,072 (0.003°)		17		
Mount	ø19.05 [0.750] BC, 2x ø3.18 [0.125] holes, 4 mm hub shaft				E54
	ø19.05 [0.750] BC, 2x ø3.18 [0.125] holes, 5 mm hub shaft				E55
	ø19.05 [0.750] BC, 2x ø3.18 [0.125] holes, 6 mm hub shaft				E56
	ø19.05 [0.750] BC, 2x ø3.18 [0.125] holes, 1/4 inch hub shaft				E5R
	ø19.05 [0.750] BC, 2x ø3.18 [0.125] holes, 8 mm hub shaft				F58
	ø19.05 [0.750] BC, 2x ø3.18 [0.125] holes, 10 mm hub shaft				F5A
	ø19.05 [0.750] BC, 2x ø3.18 [0.125] holes, 3/8 inch hub shaft				F5S
	ø20.90 [0.823] BC, 3x ø2[0.079] holes, 4 mm hub shaft				E64
	ø20.90 [0.823] BC, 3x ø2[0.079] holes, 5 mm hub shaft				E65
	ø20.90 [0.823] BC, 3x ø2[0.079] holes, 6 mm hub shaft				E66
	ø20.90 [0.823] BC, 3x ø2[0.079] holes, 1/4 inch hub shaft				E6R
	ø46.02 [0.1.812] BC, 2x ø3.18 [0.125] holes, 4 mm hub shaft				E74
	ø46.02 [0.1.812] BC, 2x ø3.18 [0.125] holes, 5 mm hub shaft				E75
	ø46.02 [0.1.812] BC, 2x ø3.18 [0.125] holes, 6 mm hub shaft				E76
	ø46.02 [0.1.812] BC, 2x ø3.18 [0.125] holes, 1/4 inch hub shaft				E7R
	ø46.02 [0.1.812] BC, 2x ø3.18 [0.125] holes, 8 mm hub shaft				F78
	ø46.02 [0.1.812] BC, 2x ø3.18 [0.125] holes, 10mm hub shaft				F7A
ø46.02 [0.1.812] BC, 2x ø3.18 [0.125] holes, 3/8 inch hub shaft				F7S	
Connection	Axial JST PCBA Connector				W-JAQ
	Radial M12 Connector 8 Pin, Male				U-PRQ

Sold & Serviced By:



Canadian and International Sales

ELECTROMATE

877-737-8698

sales@electromate.com

www.electromate.com

U.S. Sales

SERVO2GO.com

877-378-0240

sales@servo2go.com

www.servo2go.com

POSITAL

FRABA

DATASHEET

KCD-BC03B-XX17-XXXX-XXX

12. Interface

Preset Pin: The preset function can be used to adapt the encoder position to the mechanical alignment of the system. By performing a preset, the actual position value of the encoder (both, single turn and multi turn) is set to the desired preset value. The preset can be triggered via hardware or software. See manual for more detailed information.

Config Pin: The config pin is used for serial data communication. Via this interface an optional re-calibration and WIEGAND pulse testing of the kit encoder can be conducted after motor installation. A preset value can be applied as a software command. The protocol for communication is described in the manual. As alternative a graphical user interface with a Kit Control Box can be used for easy configuration and hardware setup, see website for more details. <https://www.posital.com/en/products/kit-encoders/kit-control-box.php>

Sold & Serviced By:



Canadian and International Sales

ELECTROMATE

877-737-8698

sales@electromate.com

www.electromate.com

U.S. Sales

SERVO2GO.com

877-378-0240

sales@servo2go.com

www.servo2go.com

POSITAL

FRABA

DATASHEET
KCD-BC03B-XX17-XXXX-XXX

13. Assembly Instructions

Step 1

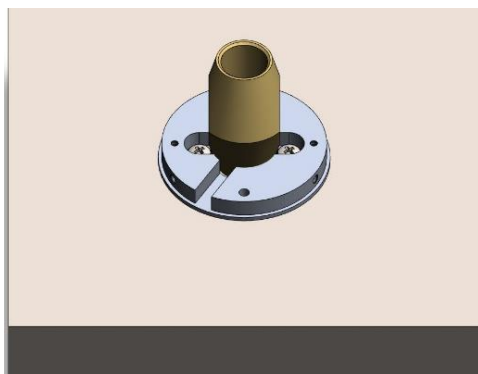
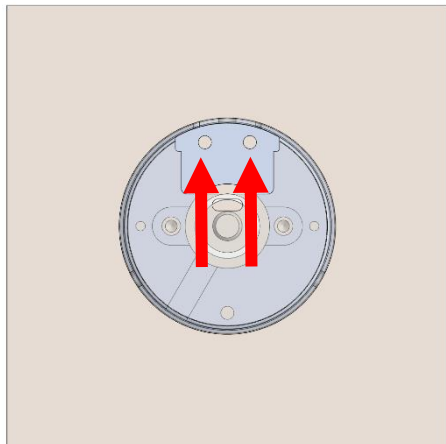
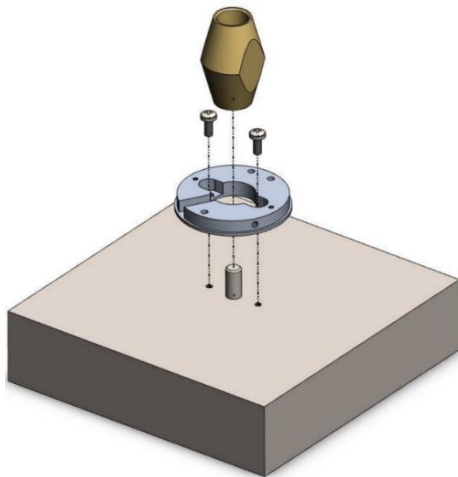

Slip adapter plate over shaft and use screws, depending on tapped holes in motor frame, to secure. Slip centering tool over shaft to center adapter plate to the shaft centerline.

For a correct flange orientation, notice the two holes shown in the image. The connector location should be always assembled relative to these two holes.

Tighten mounting screws while pushing down on the centering tool and remove centering tool. Tighten screw to a typical torque of 0.4 Nm (Actual torque value may change due to machine screw selected and base mounting material)

POSITAL

FRABA

DATASHEET

KCD-BC03B-XX17-XXXX-XXX

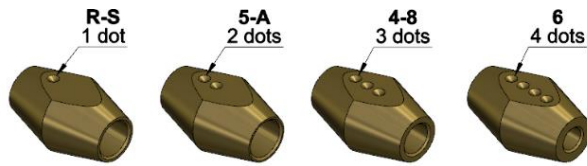

Article No.	Article Name	D1	D2	Mark
10044699	Kit-Centering-Tool-R-S	1/4"	3/8"	1 dot
10043221	Kit-Centering-Tool-5-A	5 mm	10 mm	2 dots
10046250	Kit-Centering-Tool-4-8	4 mm	8 mm	3 dots
10046251	Kit-Centering-Tool-6	6 mm	-	4 dots

Each Centering Tool is compatible with two shaft diameters and is identified by the number of dots machined into the side of the tool.

Step 2

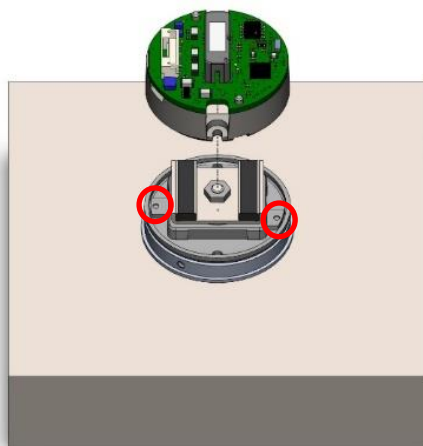
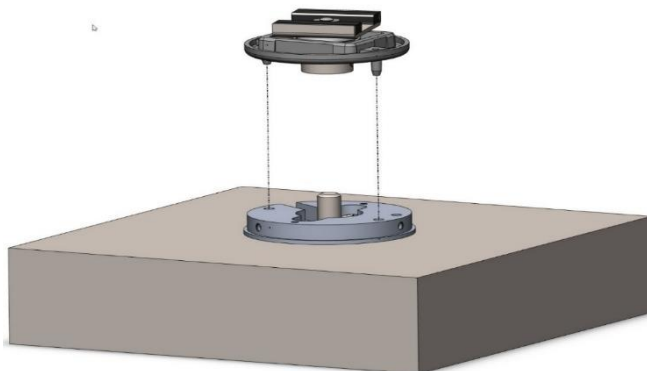

Slide bottom shield/magnet assembly over shaft and lock alignment pins into adapter plate. Push down bottom shield all the way so it lies flat on the adapter plate.

The alignment pin geometry is not symmetrical as shown by the red circles. Take care not to damage the pins during installation onto the adapter plate.

POSITAL

FRABA

DATASHEET
KCD-BC03B-XX17-XXXX-XXX

Step 3

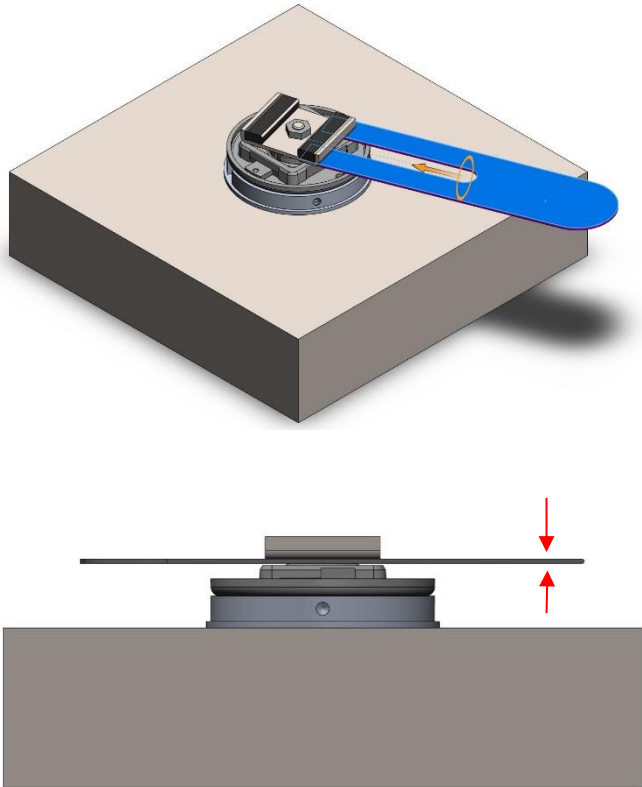

Slide gapping tool (Required thickness of 0.7mm [0.0275"]) between magnet and bottom shield. Push magnet down.

Step 4

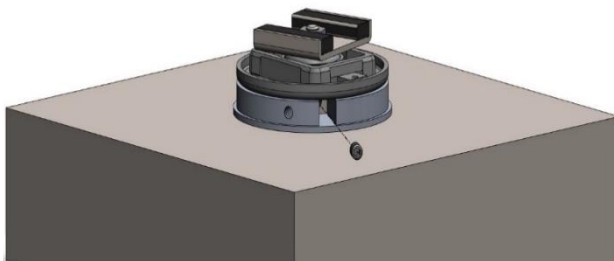

Tighten both set screws with a 1.3mm [0.05"] hex key, using the channel hole in the adapter plate with a torque of 0.5 Nm.

POSITAL

FRABA

DATASHEET
KCD-BC03B-XX17-XXXX-XXX

Step 5

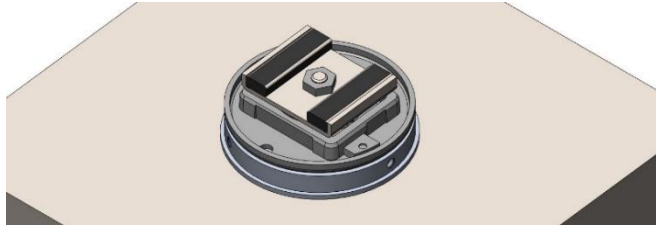

Align magnet with plastic frame on the bottom shield.

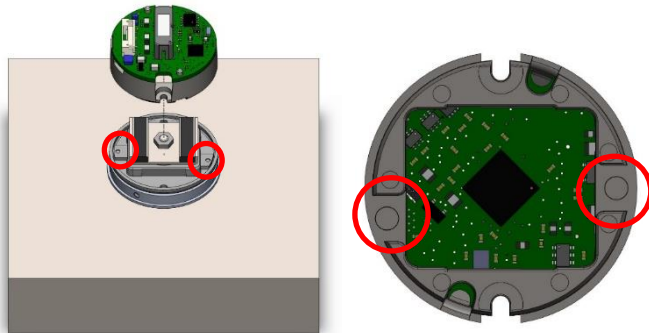

Align PCB with carrier to frame (two different keys) and push down until it locks into place.

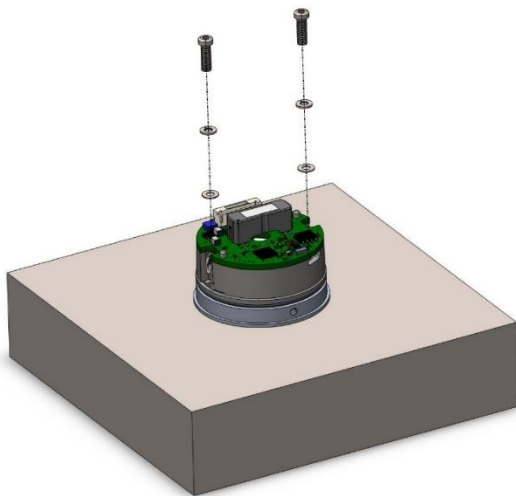

Insert two M2 screws with washers and lock washers and tighten using a Torx T6 key with a torque of 0.25 Nm.

POSITAL

FRABA

DATASHEET
KCD-BC03B-XX17-XXXX-XXX

Step 6

for JAQ Versions

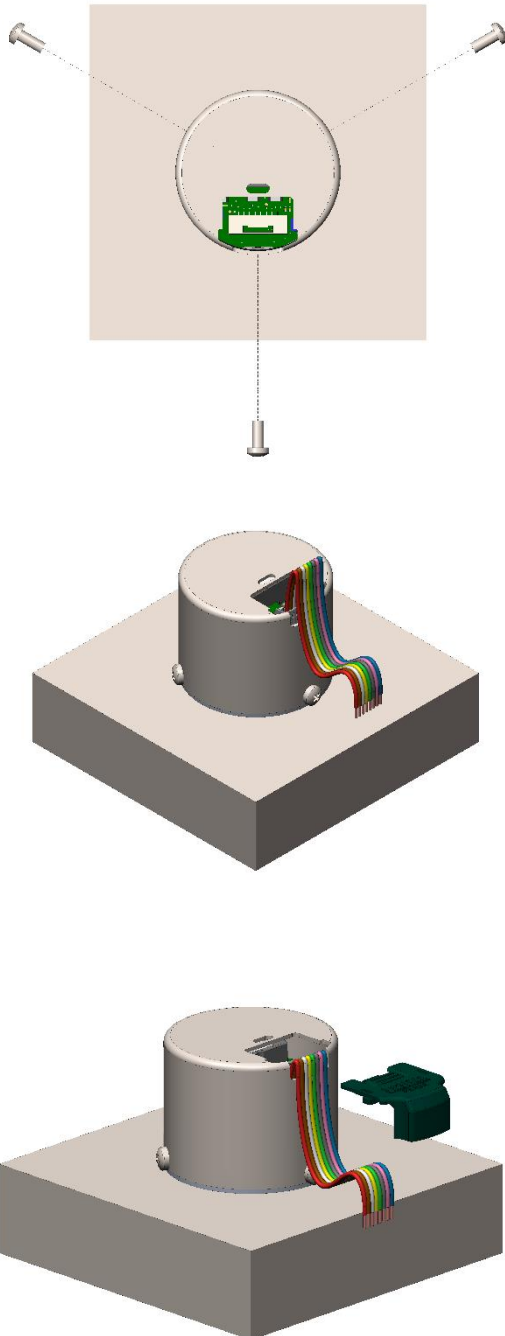

Slide housing over adapter plate. Secure housing by tightening the three M2.5 screws using a Philips screw driver with a torque of 0.4 Nm

Connect cable assembly to the PCB by plugging the connector into the PCB.

Assemble the cable clip onto the metal housing to secure the cable assembly.

POSITAL

FRABA

DATASHEET

KCD-BC03B-XX17-XXXX-XXX

for PRQ Versions

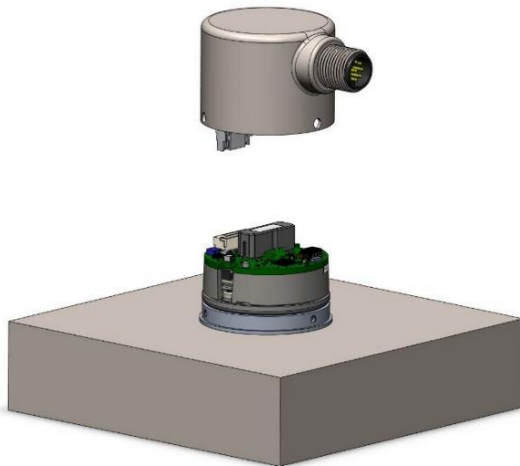

Connect JST to PCB.
Slide housing over adapter plate.
Be careful to not pinch wires.

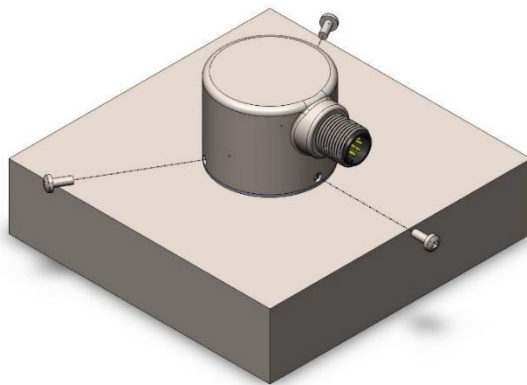

Secure housing by tightening the
three M2.5 screws using a Philips
screw driver with a torque of 0.4 Nm

POSITAL

FRABA

DATASHEET

KCD-BC03B-XX17-XXXX-XXX

Accessories

Assembly Tool Kits

Article Name	Article Number	Description
Toolkit 5/A	10046736	Assembly tools for 5mm & 10mm bores
Toolkit 4/8	10046739	Assembly tools for 4mm & 8mm bores
Toolkit R/S	10046738	Assembly tools for 1/4" & 3/8" bores
Toolkit 6	10046740	Assembly tools for 6mm bore



Cable Assemblies for M12 Connector Versions

Article Name	Article Number	Description
CBL-M12S-F08A-020DB-084N-001	10020733	M12, 8pin A-Coded, Female, 2m Shielded PUR Cable
CBL-M12S-F08A-050DB-084N-001	10007975	M12, 8pin A-Coded, Female, 5m Shielded PUR Cable
CBL-M12S-F08A-100DB-084N-001	10015616	M12, 8pin A-Coded, Female, 10m Shielded PUR Cable
CBL-R12S-F08A-020DB-084N-001	10007976	Angled M12, 8pin A-Coded, Female, 2m Shielded PUR Cable
CBL-R12S-F08A-050DB-084N-001	10017225	Angled M12, 8pin A-Coded, Female, 5m Shielded PUR Cable
CBL-R12S-F08A-100DB-084N-001	10017226	Angled M12, 8pin A-Coded, Female, 10m Shielded PUR Cable



Cable Assembly for Cable Clip Versions

Article Name	Article Number	Description
KCD BiSS C Kit - Evaluation Cable	10039297	Assembled cable for Kit evaluation, 2m



POSITAL

FRABA

DATASHEET
KCD-BC03B-XX17-XXXX-XXX

Versions

- v1 20180410 Initial Release
- v2 20181023
- v3 20200612
- v4 20200623
- v5 20200902
- v6 20201110

Contact

FRABA America
T +1 609 750-8705
➤ info@posital.com

FRABA EMEA
T +49 221 96213-0
➤ info@posital.eu

FRABA Asia
T +65 6514 8880
➤ info@posital.sg

© FRABA B.V., All rights reserved. We do not assume responsibility for technical inaccuracies or omissions. Specifications are subject to change without notice.

Sold & Serviced By:



Canadian and International Sales

ELECTROMATE

877-737-8698

sales@electromate.com

www.electromate.com

U.S. Sales

SERVO2GO.com

877-378-0240

sales@servo2go.com

www.servo2go.com