

Stepper Motors

NPM

Nippon Pulse
Your Partner in Motion Control

NIPPONPULSE.COM

Distributor by
 ELECTROMATE

Toll Free Phone (877) SERV096
Toll Free Fax (877) SERV096
www.electromate.com
info@electromate.com



Tin-Can Steppers

page 4

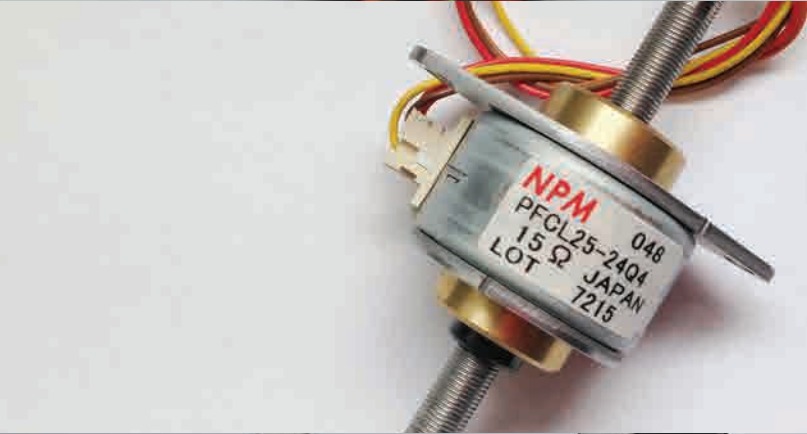

Linear Steppers

page 20

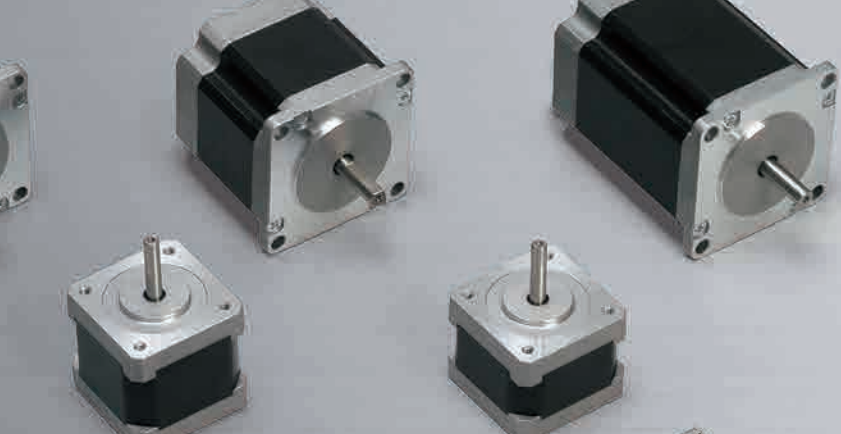

Hybrids

page 25



Linear Hybrid

page 27



Synchronous

Sold & Serviced By:
ELECTROMATE
Toll Free Phone (877) SERV098
Toll Free Fax (877) SERV099
www.electromate.com
sales@electromate.com

Stepper Motor Selection Guide

A stepper motor should provide an output torque larger than load torque and be required to start and stop at a proper step rate against load inertia. Also, while operating the motor at a rate higher than the starting pulse rate, the rate needs to be varied within a proper acceleration time. Here are some basic formulas to help you determine the torque, inertia and acceleration/deceleration time you require of the stepper motor to fit your application.

Obtaining Load Inertia

$$= \frac{Mr^2}{2} = \frac{W}{g} \times \frac{r^2}{2} = \frac{\pi r^2 \cdot L \cdot \rho \cdot r^2}{981 \times 2} = \frac{\pi \cdot \rho \cdot Lr^3}{1962}$$

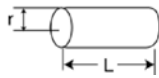

where:

- J = Load inertia (kg · cm · s²)
- π = Ratio of the circumference of a circle to its diameter (3.14)
- ρ = Specific gravity of cylinder material (kg/cm³)
(Iron = 7.8 x 10⁻³, Aluminum = 2.7 x 10⁻³)
- L = Length of cylinder (cm)
- r = Radius (cm)
- g = Gravitational acceleration 981 (cm · s⁻²)

where:

- J = Load inertia (kg · cm · s²)
- J₁ = Inertia of pulley (kg · cm · s²)
- J₂ = Inertia of take-up (kg · cm · s²)
- W = Weight of material to be wound (kg)
- r = Radius of pulley (cm)

$$J = J_1 + J_2 = \frac{\pi \rho \cdot L \cdot r^4}{1962} + \frac{Wr^2}{981}$$

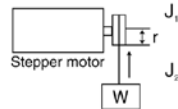

$$J = 2 \times J_1 + J_2 = 2 \left(\frac{\pi \rho L r^4}{1962} \right) + \frac{Wr^2}{981}$$

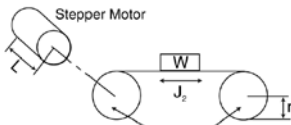

Pulley J₁ x 2

where:

- J = Load inertia (kg · cm · s²)
- J₁ = Inertia of pulley (kg · cm · s²)
- J₂ = Inertia of linear movement (kg · cm · s²)
- W = Weight of belt and material (kg)
- r = Radius of pulley (cm)
- L = Length (cm)

$$J_2 = J_1 + (J_2 + J_3) \left(\frac{N_1}{N_2} \right)^2 + J_4$$

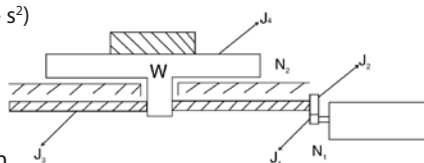

where:

- J₀ = Load inertia (kg · cm · s²)
- J₁ = Inertia of pinion (kg · cm · s²)
- J₂ = Inertia of gear (kg · cm · s²)
- J₃ = Inertia of feed screw (kg · cm · s²)
- J₄ = Inertia of work and table (kg · cm · s²)
- N₁ = Number of pinion teeth
- N₂ = Number of gear teeth
- W = Weight of work and table (kg)
- π = Ratio of the circumference of a circle to its diameter (3.14)
- α = Step angle per pulse (°)
- δ = Table movement per pulse (cm)
- P = Pitch of feed screw (cm)

$$J_1 = \frac{W}{981} \left(\frac{\delta}{\frac{\pi}{180} \cdot \alpha} \right)^2$$

$$\text{or } J_2 = \frac{W}{981} \left(\frac{P}{2\pi} \cdot \frac{N_1}{N_2} \right)^2$$

Obtaining Load Torque

$$T = F \times r$$

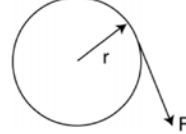

where:

- T = Load torque (kg · cm)
- F = Force to rotate the coupling shaft of a stepper motor (cm)
- r = Radius to apply the force (F) (cm)

where:

- T = Load torque (kg · cm)
- N₁ = Number of pinion teeth
- N₂ = Number of gear teeth
- W = Weight of table and work (kg)
- F = Cutting resistance (kg)

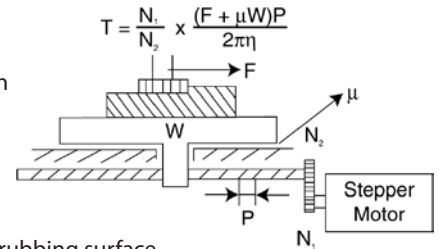

$$T = \frac{N_1}{N_2} \times \frac{(F + \mu W)P}{2\pi\eta}$$

μ = Frictional resistance of rubbing surface

P = Pitch of feed screw (cm)

η = Transfer efficiency of the system including feed screw and gear

Obtaining Acceleration/Deceleration Time

$$t_{acc} = (J_r + J_l) 2\pi * (f_h - f_l) / (nq * T_a)$$

where:

- t_{acc} = Acceleration time (S)
- J_r = Rotor inertia (g · cm · s²)
- J_l = Load inertia (g · cm · s²)

f_h = Slew speed (pps)

f_l = Starting speed (pps)

nq = Step/revolution

T_a = Acceleration torque (g · cm)

Obtaining Acceleration/Deceleration Torque

$$T_a = (J_r + J_l) 2\pi * (f_s)^2 / (nq * n)$$

where:

T_a = Acceleration torque (g · cm)

J_r = Rotor inertia (g · cm · s²)

J_l = Load inertia (g · cm · s²)

f_s = Max no load slew rate under specific drive conditions (pps)

nq = Step/revolution

n = Index No for drive method (Full step mode = 2; Half step mode = 4)

Calculating Output Torque From Gearhead

$$T_{gh} = T_m \times G_r \times 0.85^n$$

where:

T_{gh} = Torque from Gearhead

T_m = Torque from motor

G_r = Gearhead ratio (# of times motor turns per 1 turn of gearhead)

example: 1/3 gearhead G_r = 3

n = Number of gears

Sold & Serviced By:

ELECTROMATE

Toll Free Phone (877) SERV098

Toll Free Fax (877) SERV099

www.electromate.com

sales@electromate.com

Nippon Pulse Stepper Motors

Permanent Magnet Motors

Nippon Pulse's permanent magnet (PM) step motors (PF series tin-can steppers) have been well-established in the engineering world, and have many advantages over other kinds of stepper motors. PM motors strike the perfect balance between efficiency and affordability, as they are low-inertia, low-resolution motors that are a low-priced alternative to hybrid stepper motors in many applications.

PM step motors have a typical step angle between 3.75 and 18 degrees, and offer position resolution on the order of ± 5 percent. Its structure demonstrates ferromagnetism, with alternating north and south poles set in a straight, parallel line to the rotor shaft. The rotor is moved through the action of permanent magnets, providing increased magnetic flux intensity. This intensity results in improved torque characteristics for the PM motor, compared to variable resistance step motors.

Nippon Pulse provides high-quality PM motors to industries and professionals all over the world. Take a look at our standard PM motors over the following pages to find the one that most closely fits your needs. An application engineer can work with you to make any customizations necessary to make our PM motors a perfect fit.

Basic Structure of 2-Phase Permanent Magnet Motor

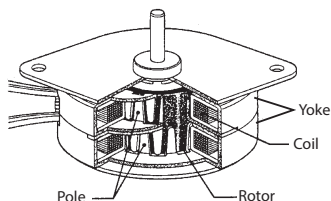

Below are Nippon Pulse's permanent magnet stepper motors:

- **PF series** - Nippon Pulse's original PM stepper motors
- **PFC series** - PF series tin-can steppers with a fully automated coil assembly
- **PFL series (Linearstep)** - linear actuators that utilize the PF series construction
- **NFC series** - high-force, short-stroke linear actuators that utilize the PF series construction
- **PTM/PTMC series** - synchronous timing motors based on the PF series.

Insulation Ratings

Insulation Class	Y	A	E	B	F	H	C
Allowable Temp (°C)	90	105	120	130	155	180	>180

Note: All tin-can motors and linear steppers in this catalog are insulation Class E unless otherwise noted.

Terminology

Continuous Rating

Specifications are continuously applicable to the rated output.

Dielectric Strength

The maximum voltage between the case and the coils that can be sustained for one minute without damaging the motor.

- 500Vac for one minute with operating voltage <30V
- 1000Vac for one minute with operating voltage 30-150V
- 1500Vac for one minute with operating voltage >150V

Intermittent Rating

Specifications are applicable for a specific time length to the rated output.

Motor Speed

Number of revolutions per minute.

Operating Temperature Range

Ambient temperature range in which the motor can normally be driven.

Operating Voltage Range

The voltage range in which the motor can normally be driven with Constant Voltage drive.

Temperature Rise

The temperature of the motor rises whenever power is applied. Temperature rise is determined by applying the motor's rated voltage and measuring the increased coil resistance or the change in surface temperature of the motor.



PFL35T and PFC25

Abbreviations/Units

A

SI base unit for current (ampere)

AC

Alternating current

CCW

Counterclockwise

CW

Clockwise

DC

Direct Current

Hz

SI induced unit for frequency (cycles per second)

K

SI base unit for temperature (Kelvin); often used for temperature rise

PPS

Pulses per second

RPM

Revolutions per minute

V

SI induced unit for voltage (volts)

RoHS Compliance

All Nippon Pulse stepper motor products are RoHS compliant.



Tin-Can Models by Outer Diameter

OD (mm)	Tin-Can	Synchronous		Linear Stepper
		Dual Direction	Single Direction	
10	PFC10	--	--	--
20	PFCU20 PFC20T	--	--	--
25	PF(C)25 PFCU25	PTM-24P	--	PFCL25
30	PFCU30	--	--	--
35	PF35 PFC35T	PTM-24M PTM-24T	PTM-24B	PFL35T
42	PF42 PFC42H PF(C)42T	PTM-24H PTMC-24S2	PTM-12K PTM-12E	--
55	PF(C)55 PFC55H	PTM-24F		

Sold & Serviced By: **ELECTROMATE**

Toll Free Phone (877) SERV098
Toll Free Fax (877) SERV099
www.electromate.com
sales@electromate.com

Permanent Magnet Motor Features and Customization Options

Coil

An encapsulated and welded stator design gives stronger design, greater dimensional control and improved thermal characteristics.

Mounting Plate

Custom and standard shaped mounting plates are available. Mounting holes can be threaded, tapped, slotted or customized to your application requirements.

Permanent Magnet Rotor

Three types of permanent magnets are available: ferrite anisotropic, ferrite isotropic, and neodymium.

Bushings and Bearings

Long life oil-impregnated bushings are standard in our PF, PFC, NFC, PTM and PTMC motors. Ball bearings can be requested, and are standard in the PFL series Linearstep motors.

Shaft

A variety of shaft options are available.

- Custom lengths
- Single and double shafts
- D-cut(s)
- Turn downs
- Threaded
- Knurled
- Grooved

Gears & Pulleys

A variety of gear and pulley options are available.

- Machined
- Plastic molded
- Powdered metal (sintered)

Connector

Motor side connection method. Lead wire options available.

Lead Wire

Options to change the lead wire exit direction and exit angle.

Wire Leads

Driver side connector options.

- Standard flying leads
- Customer-selected connectors

See page 41 for additional motor customization options and for information about creating a fully custom step motor.

Unipolar Drive

Six lead wires are connected

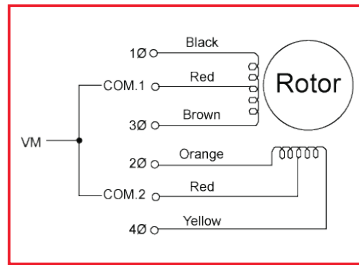

Current: Single direction
Coil: Bifilar winding
Leadwires: 6

The basic circuit (constant voltage) is shown to the right

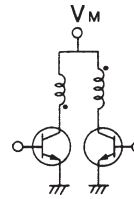

2-2 phase excitation sequence

Step	Black	Brown	Orange	Yellow	Step
1	ON	OFF	ON	OFF	4
2	OFF	ON	ON	OFF	3
3	OFF	ON	OFF	ON	2
4	ON	OFF	OFF	ON	1

↑ CCW
↓ CW

Bipolar Drive

Four lead wires are connected

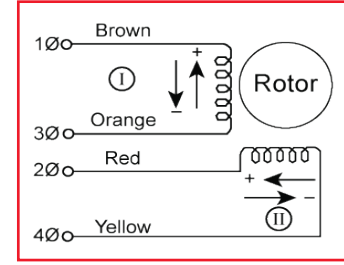

Current: Dual direction
Coil: Monofilar winding
Leadwires: 4

The basic circuit (constant voltage) is shown to the right

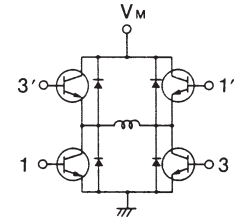

2-2 phase excitation sequence

Step	I	II
1	+	+
2	-	+
3	-	-
4	+	-

↑ CCW
↓ CW

		Unipolar	Bipolar
Number of Transistors		1	2
To ensure the same temperature rise of motor	Current	1	1/√2
	Torque	1	√2
	High-speed performance	1	0.5
	Voltage	1	√2
To obtain same torque	Current	1	0.5
	Temperature rise	1	0.5
	High-speed performance	1	0.5
	Voltage	1	1

This chart shows the comparison between bipolar and unipolar drives with parameters of unipolar set to one.

Model Number Explanation (for PF and PFC series)

PF(C) - 42 T - 48 C 1 G 1/50
1 2 3 4 5 6 7 8

1 - Series Designation

PF: Flying lead joint type
PFC: Connector joint type

2 - Outer Diameter in mm

3 - Type

Blank: Standard
T: Thin stack
H: High torque

4 - Steps per Revolution

24: 15°/step
48: 7.5°/step
96: 3.75°/step

5 - Winding

C: 12V unipolar
D: 5V unipolar
P: 12V bipolar
Q: 5V bipolar

6 - Magnet Material

1: Ferrite Anisotropic
3: Ferrite Isotropic
4: Neodymium
6: Molded Neodymium*

7 - Gear Head

Blank: No Gear Head
G: Gear Head Integrated

8 - Gear Ratio

With geared models only

*Only applicable for PFC10 and PFC20T.

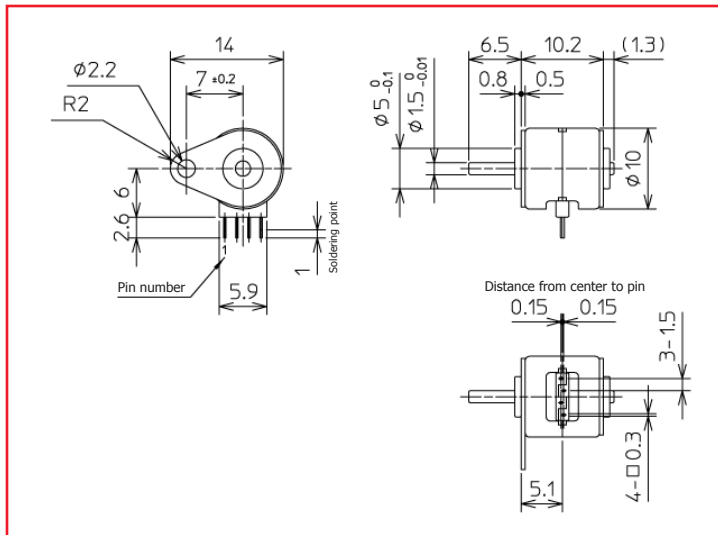

Specifications

Specification	Unit	PFC10-20R6
Type of Winding		Bipolar
Excitation Mode*		Full step (2-2)
Steps/Revolution		20
Step Angle	°	18
Holding Torque	mN·m	1.0
Rated Voltage	V	2.7
Rated Current	mA/phase	135
Resistance	Ω	20
Inductance	mH / ϕ	3.2
Winding		R
Starting Pulse Rate	pps	960
Slewing Pulse Rate	pps	1600
Rotor Inertia	kg·m ²	0.03×10^{-7}
Operating Temp. Range	°C	-10 to +50
Storage Temp. Range	°C	-30 to +80
Insulation Class		E
Temperature Rise	K	70
RoHS Compliant		Yes
Weight	g	5

Torque Curve Characteristics

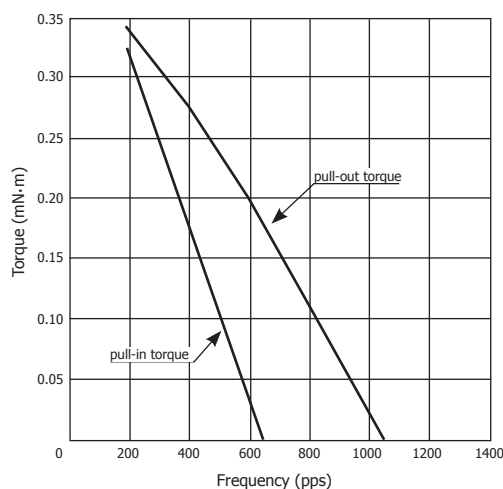

Pin	Coil Phase
1	$4\phi \bar{B}$
2	$1\phi A$
3	$2\phi B$
4	$3\phi \bar{A}$

All tin-can motor specifications are based on full-step constant voltage operation. When the rated voltage is 5V, the terminal voltage is 4V. Do not use this product over maximum operating temperature (100°C).

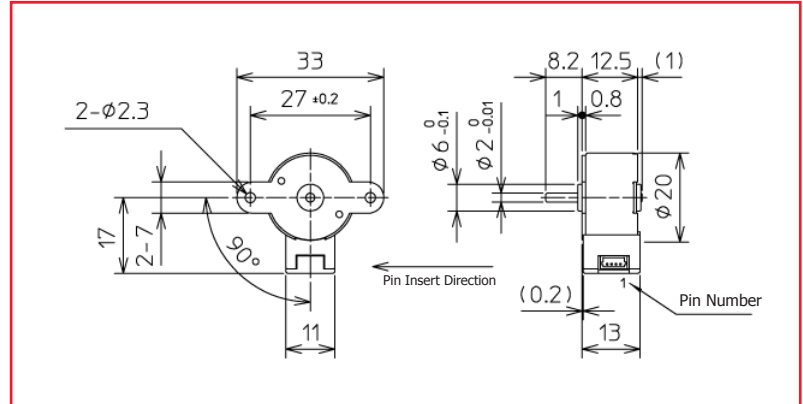

Specifications

Specification	Unit	PFC20T-20V6
Type of Winding		Bipolar
Excitation Mode*		Full step (2-2)
Steps/Revolution		20
Step Angle	°	18
Holding Torque	mN·m	4.4
Rated Voltage	V	8.7
Rated Current	mA/phase	87
Resistance	Ω	100
Inductance	mH	35
Winding		V
Starting Pulse Rate	pps	620
Slewing Pulse Rate	pps	1080
Rotor Inertia	kg·m ²	0.2 x 10 ⁻⁷
Operating Temp. Range	°C	-10 to +50
Storage Temp. Range	°C	-30 to +80
Insulation Class		E
Temperature Rise	K	70
RoHS Compliant		Yes
Weight	g	24

All tin-can motor specifications are based on full-step constant voltage operation. When the rated voltage is 15V, the terminal voltage is 12V-11V. Do not use this product over maximum operating temperature (100°C).

Torque Curve Characteristics

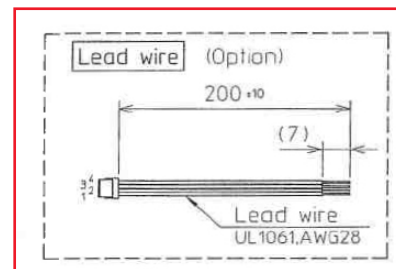
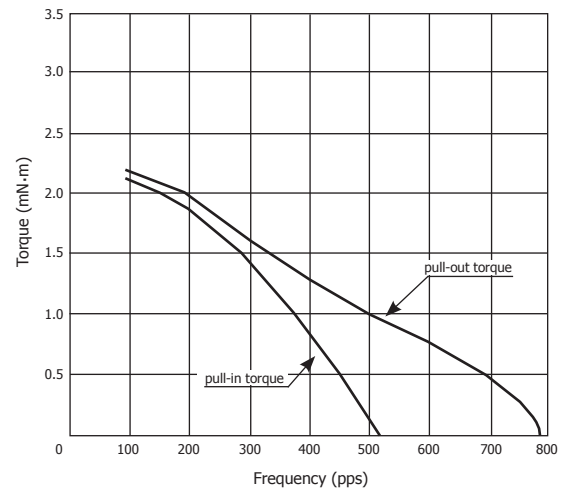

Connector (JST)

Applicable Housing: SHR-04V-S
 Applicable Contact: SSH-003T-P0.2-H
 Applicable Wire: AWG 32 to 28 (outer diameter of wire insulation: 0.4 to 0.8 mm)

Pin	Coil Phase
1	4 ϕ B
2	2 ϕ B
3	3 ϕ A
4	1 ϕ A

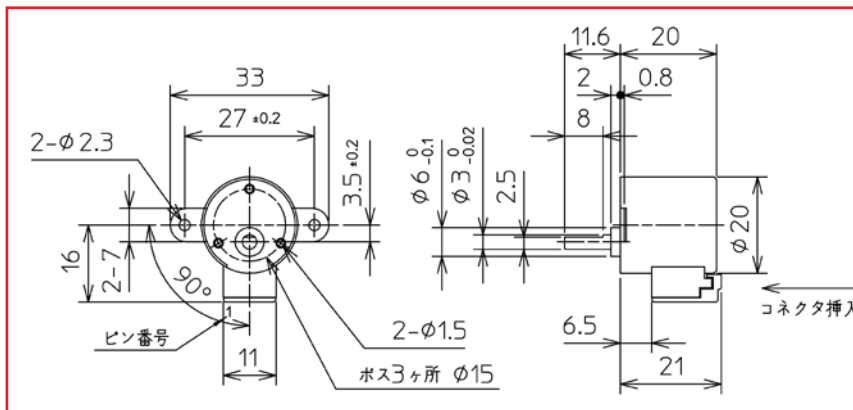

Specifications

Specification	Unit	PFCU20-40_-4GM2 (1/10)		PFCU20-40_-4GM2 (1/18)	
Excitation Mode		Full-step (2-2)			
Step Angle	°	0.9		0.5	
Steps Per Revolution*		400		720	
Winding		S	V	S	V
Rated Voltage	V	11	8.7	11	8.7
Resistance ¹	Ω	160	100	160	100
Inductance ¹	mH/φ	59	39	59	39
Maximum Torque	mN·m	20			
Destruction Torque	mN·m	60			
Gear Ratio/Backlash	pps	1/10		1/18	
Operating Temp. Range	°C	-10 ~ +50			
Temperature Rise*	K	70			
Weight	g	25			

All tin-can motor specifications are based on full-step constant voltage operation.

Magnet type: Neodymium

¹ Supply voltage 12V ±2% and at a temperature of 20°C ±5% and relative humidity 65% ±20%.

² Stated terminal voltage is with supply voltage 12V.

³ Stated temperature rise is at the time of saturation.

*Under test conditions

Connector (JST)

Applicable Housing: SHR-04V-S

Applicable Contact: SSH-003T-P0.2-H

Applicable Wire: AWG 32 to 28 (outer diameter of wire insulation: 0.4 to 0.8 mm)

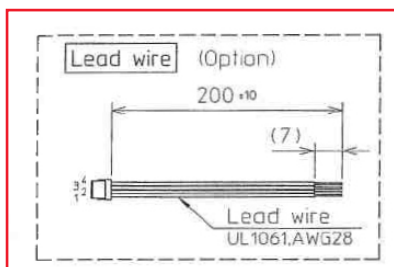

Pin	Coil Phase
1	4φ B-
2	3φ A-
3	1φ A
4	2φ B

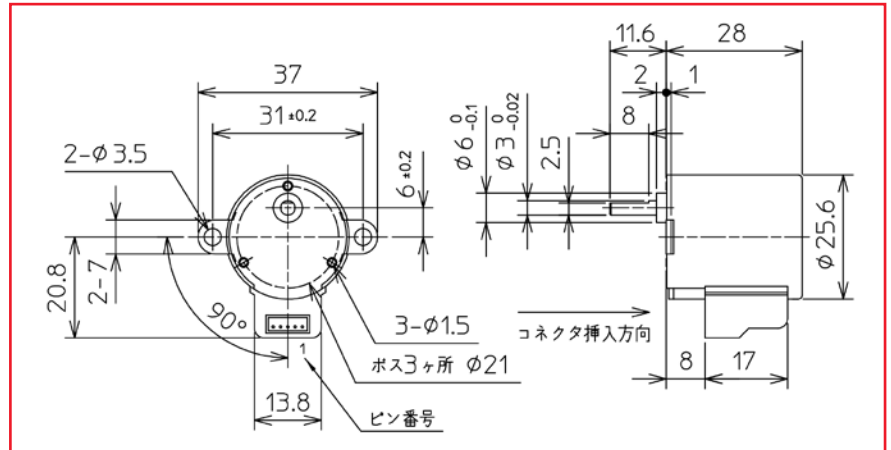

Specifications

Specification	Unit	PFCU25-24_-1GM (1/18)		PFCU25-24_-1GM (1/20)		PFCU25-24_-1GM (1/30)	
Excitation Mode		Full Step (2-2)					
Step Angle	°	1		0.75		0.5	
Steps Per Revolution*		360		480		720	
Winding		P	T	P	T	P	T
Rated Voltage	V	12.6	6.5	12.6	6.5	12.6	6.5
Resistance ¹	Ω	122	32	122	32	122	32
Inductance ¹	mH/φ	66	16	66	16	66	16
Maximum Torque	mN·m	50					
Destruction Torque	mN·m	150					
Operating Temp. Range	°C	-10 ~ +50					
Temperature Rise*	K	70					
Weight	g	55					
Gear Ratio, Backlash		1/15		1/20		1/30	

All tin-can motor specifications are based on full-step constant voltage operation,
Magnet type: Anisotropic

¹ Supply voltage 12V ±2% and at a temperature of 20°C ±5% and relative humidity 65% ±20%.

² Stated terminal voltage is with supply voltage 12V.

³ Stated temperature rise is at the time of saturation.

*Under test conditions

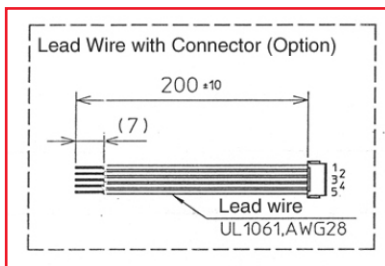

Pin	Coil Phase
1	3φ A-
2	2φ B
3	1φ A
4	4φ B-

Connector (JST)

Applicable Housing: ZHR-4

Applicable Contact: SZH-002T-P0.5

Applicable Wire: AWG 28 to 26 (outer diameter of wire insulation: 0.8 to 1.1 mm)

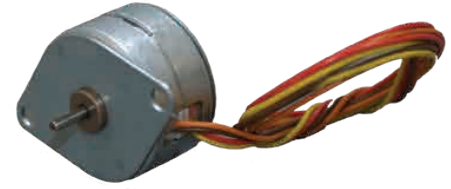
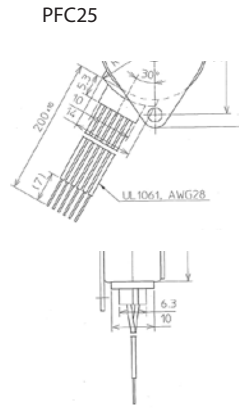
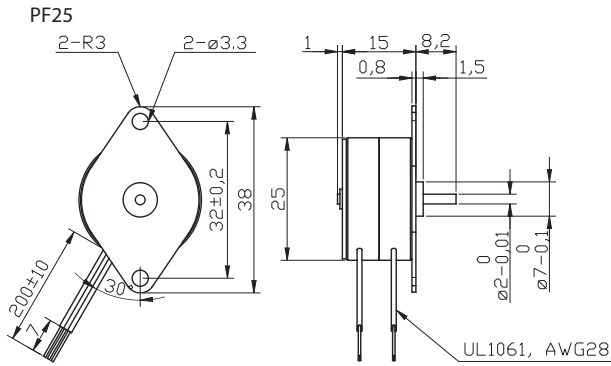

Specifications

Specification	Unit	PF(C)25-24				PF(C)25-48			
		Unipolar		Bipolar		Unipolar		Bipolar	
Type of Winding		Unipolar				Bipolar			
Excitation Mode*		Full step (2-2)				Full step (2-2)			
Step Angle	°	15 ±5%				7.5 ±5%			
Steps Per Revolution*		24				48			
Winding		C	D	P	Q	C	D	P	Q
Rated Voltage	V	12	5	12	5	12	5	12	5
Resistance	Ω	120	16	122	15	120	16	122	15
Inductance	mH	34	4.5	66	8	37	5	81	10
Holding Torque*	mN·m	8	8	10	10	10	10	12	12
Rotor Inertia	kg·m ²	1.0 x 10 ⁻⁷				1.0 x 10 ⁻⁷			
Starting Pulse Rate*	pps	490				790			
Slewing Pulse Rate*	pps	900							
Operating Temp. Range	°C	-10 to +50							
Temperature Rise*	K	70							
Weight	g	35							

Dimensions of Geared Model

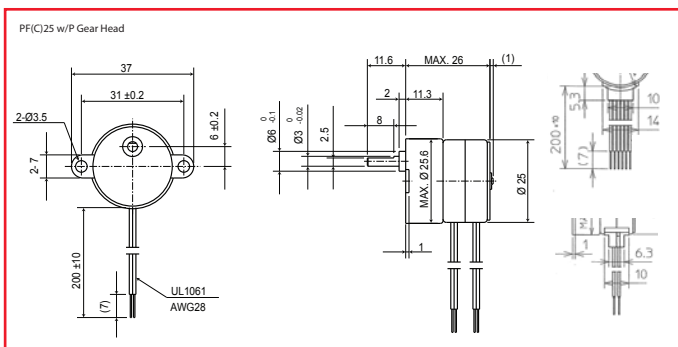

Gear Ratio	6/25	1/5	3/25	1/10	2/25	1/15	3/50	1/20
Ordinary Torque	20mN·m				50mN·m			
Destruction Torque	60mN·m				150mN·m			

Gear Ratio	1/25	1/30	1/50	1/60	1/75	2/125
Ordinary Torque	70mN·m					
Destruction Torque	210mN·m					

Gear Ratio	1/100	1/120	1/125	1/150	1/200	1/250	1/300
Ordinary Torque	100mN·m						
Destruction Torque	300mN·m						

Torque Curve (pull-out torque)*

Bipolar Constant Voltage (48P1)

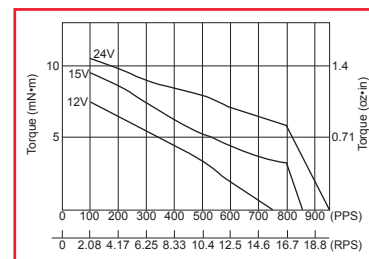

Coil Resistance: 122Ω

Bipolar Constant Current (48R1)

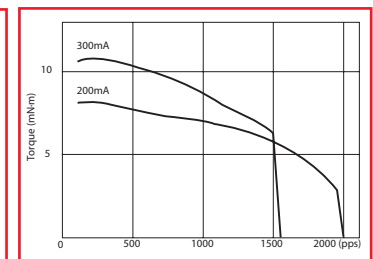

Coil Resistance: 35Ω Supply Voltage: 24V

Unipolar Constant Voltage (48C1)

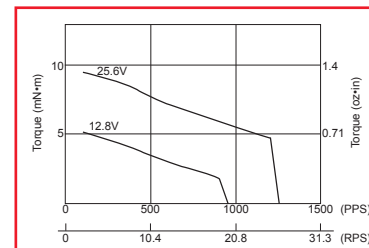

Coil Resistance: 120Ω

Unipolar Constant Current (48H1)

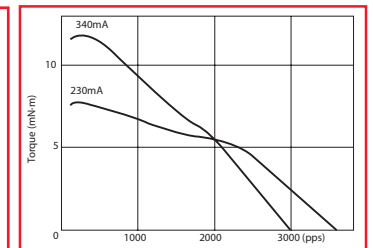

Coil Resistance: 34Ω Supply Voltage: 24V

All tin-can motor specifications are based on full-step constant voltage operation.
Magnet type: Anisotropic

*Torque curves are for reference only and are not guaranteed

Sold & Serviced By:

ELECTROMATE

Toll Free Phone (877) SERV098
Toll Free Fax (877) SERV099
www.electromate.com
sales@electromate.com

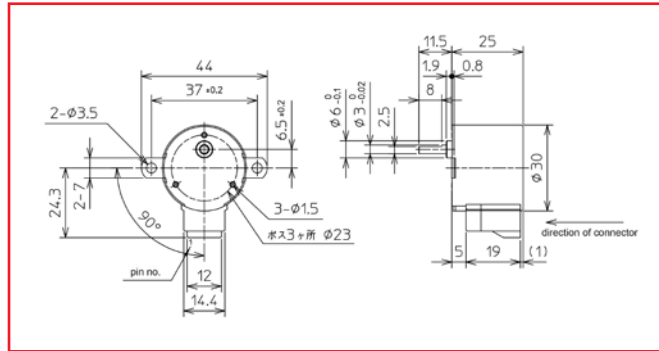

Specifications

Specifications	Unit	PFCU30-24_-4GM (1/5)		PFCU30-24_-4GM (3/25)		PFCU30-24_-4GM (1/12)	
Type of Winding		Bipolar					
Excitation Mode*		Full step (2-2)					
Step Angle	°	3		1.8		1.25	
Steps Per Revolution*		120		200		288	
Gear Ratio		1/5		3/25		1/12	
Winding		T	V	T	V	T	V
Rated Voltage	V	9.8	6.9	9.8	6.9	9.8	6.9
Resistance	Ω	60	30	60	30	60	30
Inductance	mH / φ	49	26	49	26	49	26
Ordinary Torque	mN·m	100					
Destruction Torque	mN·m	300					
Operating Temp. Range	°C	-10 ~ +50					
Storage Temp. Range	°C	-30 ~ +80					
Temperature Rise*	K	70 (at 700pps)					
Weight	g	75					

PFCU30-24_-4GM(3/25) vs. PJP28T32E16 (Hybrid)

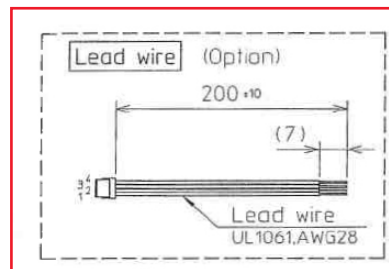
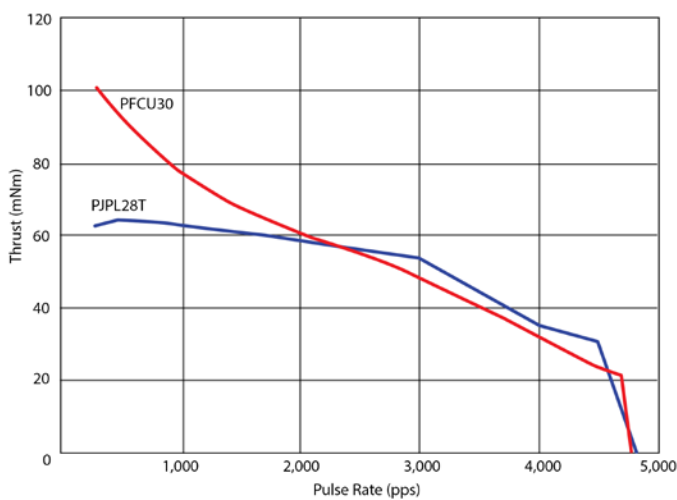

Connector

Applicable Housing: ZHR-4
 Applicable Contact: SZH-002T-P0.5
 Applicable Wire: AWG 28 to 26 (outer diameter of wire insulation: 0.4 to 0.8 mm)

Pin	Coil Phase
1	4φ B-
2	3φ A-
3	1φ A
4	2φ B

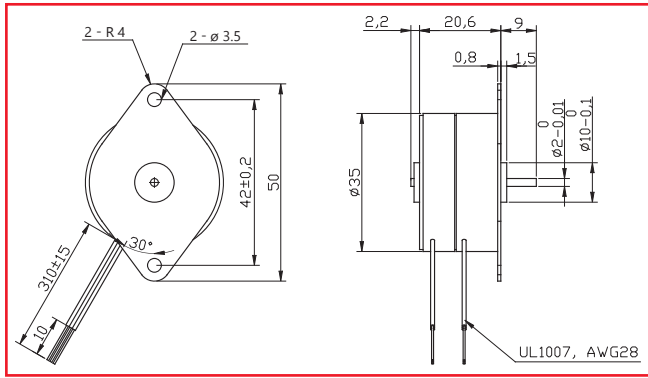

Specifications

Specification	Unit	PF35-24				PF35-48			
		Unipolar		Bipolar		Unipolar		Bipolar	
Type of Winding		Unipolar				Bipolar			
Excitation Mode*		Full step (2-2)				Full step (2-2)			
Step Angle	°	15 ±5%				7.5 ±5%			
Steps Per Revolution*		24				48			
Winding		C	D	P	Q	C	D	P	Q
Rated Voltage	V	12	5	12	5	12	5	12	5
Resistance	Ω	90	16	100	17	90	16	100	17
Inductance	mH	37	8.7	95	14	48	8.9	124	19
Holding Torque	mN·m	15	15	19	19	20	20	25	25
Rotor Inertia	kg·m ²	4.5 x 10 ⁻⁷				4.5 x 10 ⁻⁷			
Starting Pulse Rate*	pps	310				500			
Slewing Pulse Rate*	pps	410				530			
Operating Temp. Range	°C	-10 to +50							
Temperature Rise*	K	55							
Weight	g	80							

Torque Curve (pull-out torque)*

Bipolar Constant Voltage (48P1)

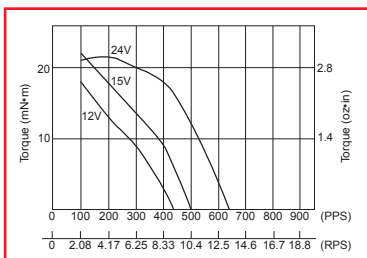

Coil Resistance: 100Ω

Bipolar Constant Current (48181)

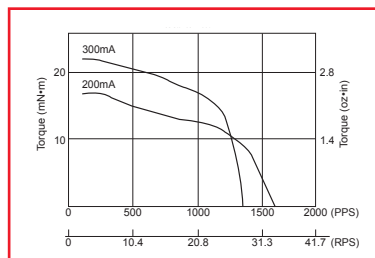

Coil Resistance: 18Ω Supply Voltage: 24V

Unipolar Constant Voltage (48C1)

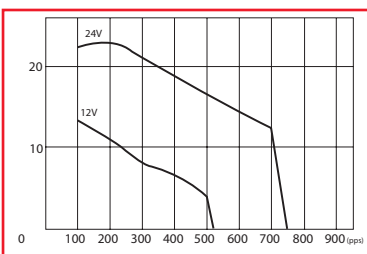

Coil Resistance: 90Ω

Unipolar Constant Current (48071)

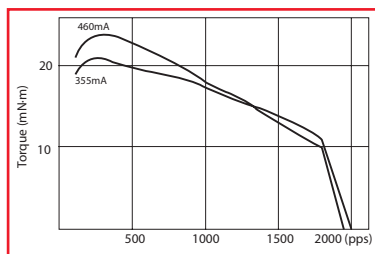

Coil Resistance: 20Ω Supply Voltage: 24V

Dimensions of Geared Model

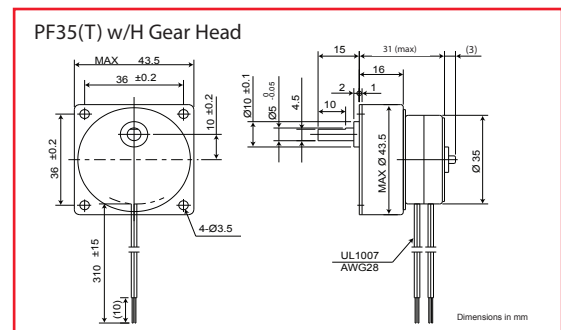

Gear Ratio	6/25	1/5	3/25	1/10
Ordinary Torque	200mN·m			
Destruction Torque	600mN·m			

Gear Ratio	2/25	1/15	3/50	1/20	1/25
Ordinary Torque	250mN·m				
Destruction Torque	750mN·m				

Gear Ratio	1/30	1/50	1/60	2/125	1/75
Ordinary Torque	300mN·m				
Destruction Torque	900mN·m				

Gear Ratio	1/100	1/120	1/125	1/150	1/200	1/250	1/300
Ordinary Torque	400mN·m						
Destruction Torque	1200mN·m						

All tin-can motor specifications are based on full-step constant voltage operation.

Magnet type: Anisotropic

*Torque curves are for reference only and are not guaranteed

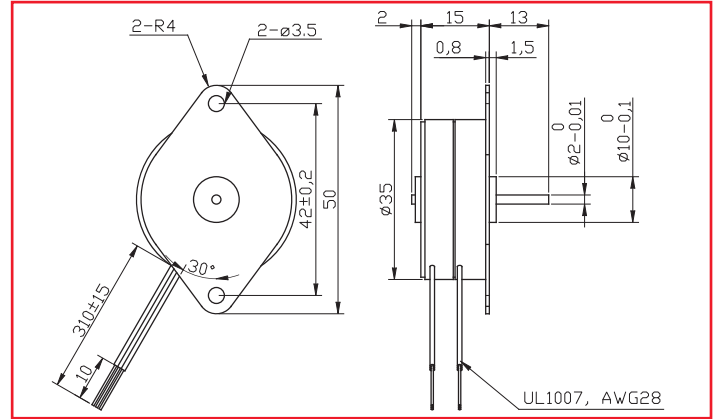
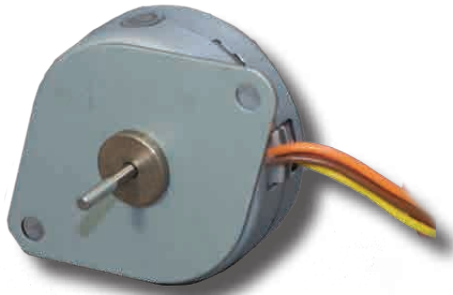

Specifications

Specifications	Unit	PF35T-48			
Type of Winding		Unipolar		Bipolar	
Excitation Mode*		Full step (2-2)			
Step Angle	°	7.5 ±5%			
Steps Per Revolution*		48			
Winding		C	D	R	Q
Rated Voltage	V	12	5	12	5
Resistance	Ω	70	12	72	16
Inductance	mH	30	6.5	60	6.2
Holding Torque	mN·m	18	18	27	27
Rotor Inertia	kg·m ²	2.7 x 10 ⁻⁷			
Starting Pulse Rate*	pps	600			
Slewing Pulse Rate*	pps	610			
Operating Temp. Range	°C	-10 to +50			
Temperature Rise*	K	70			
Weight	g	77			

Dimensions of Geared Model

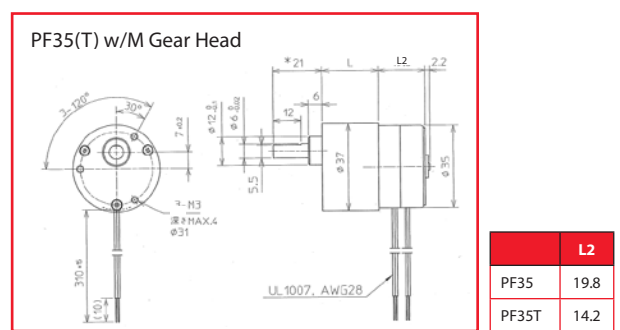

Gear Ratio	1/5	1/6	1/10	1/12	1/15	1/18	1/25	1/30
Ordinary Torque	100mN·m			200mN·m				
Destruction Torque	300mN·m			600mN·m				

Gear Ratio	1/40	1/50	1/60	1/75	1/90	1/100	1/120
Ordinary Torque	300mN·m						
Destruction Torque	900mN·m						

Gear Ratio	1/5	1/6	1/10	1/18	1/30	1/40	1/50	1/60	1/75	1/90	1/100	1/120	1/125	1/150	1/180	1/200	1/300
L	19.5	19.5	19.5	19.5	19.5	21.7	21.7	21.7	21.7	21.7	21.7	21.7	23.8	23.8	23.8	23.8	23.8

Gear Ratio	1/125	1/150	1/180	1/200	1/250	1/300
Ordinary Torque	600mN·m					
Destruction Torque	1800mN·m					

Available with H or M gearhead. See previous page for H gearhead drawing.

Torque Curve (pull-out torque)*

Bipolar Constant Voltage (48R1)

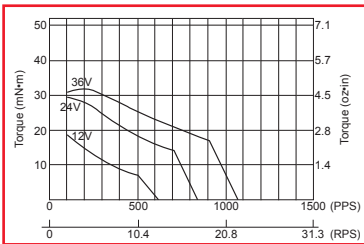

Coil Resistance: 72Ω

Bipolar Constant Current (48Q1)

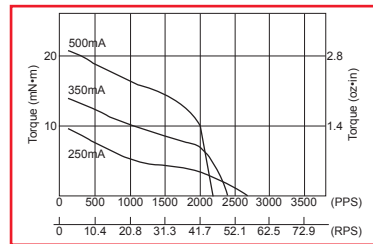

Coil Resistance: 16Ω Supply Voltage: 24V

Unipolar Constant Voltage (48C1)

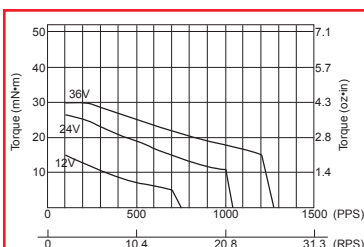

Coil Resistance: 70Ω

Unipolar Constant Current (48D1)

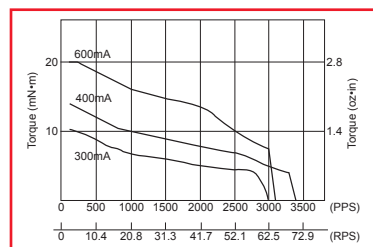

Coil Resistance: 12Ω Supply Voltage: 24V

*Torque curves are for reference only and are not guaranteed.
All specifications are based on full-step constant voltage operation.
Magnet type: Anisotropic

Sold & Serviced By:
ELECTROMATE
Toll Free Phone (877) SERV098
Phone Fax (813) SERV099
www.elect-mate.com
sales@electromate.com

NIPPONPULSE.COM

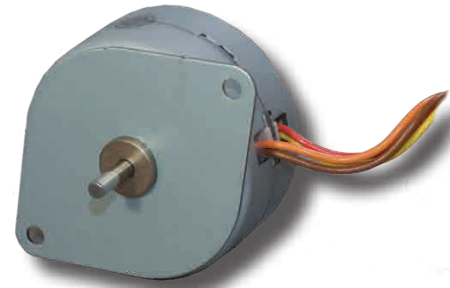
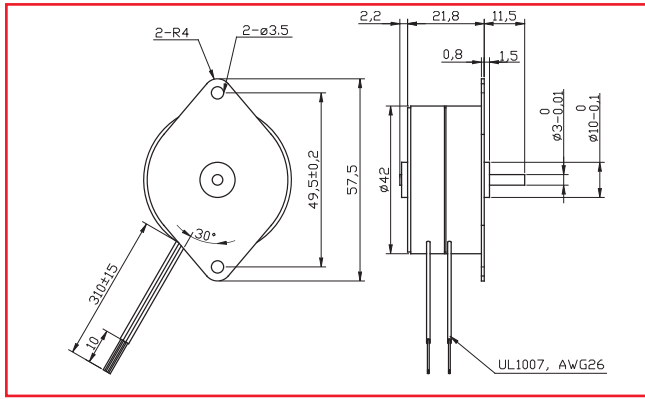

Specifications

Specification	Unit	PF42-24				PF42-48			
		Unipolar		Bipolar		Unipolar		Bipolar	
Type of Winding		Unipolar		Bipolar		Unipolar		Bipolar	
Excitation Mode*		Full step (2-2)				Full step (2-2)			
Step Angle	°	15 ±5%				7.5 ±5%			
Steps Per Revolution*		24				48			
Winding		C	D	P	Q	C	D	P	Q
Rated Voltage	V	12	5	12	5	12	5	12	5
Resistance	Ω	70	12	76	14	70	12	76	14
Inductance	mH	35	5.9	74	14	41	6.1	87	16
Holding Torque	mN·m	28	28	41	41	45	45	54	54
Rotor Inertia	kg·m ²	16.8 × 10 ⁻⁷				12.8 × 10 ⁻⁷			
Starting Pulse Rate*	pps	180				310			
Slewing Pulse Rate*	pps	250				320			
Operating Temp. Range	°C	-10 to +50							
Temperature Rise*	K	55							
Weight	g	160							

Dimensions of Geared Model

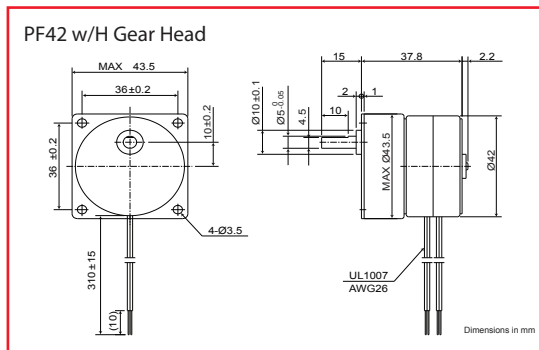

Gear Ratio	6/25	1/5	3/25	1/10	2/25	1/15	3/50	1/20	1/25
Ordinary Torque	200mN·m				250mN·m				
Destruction Torque	600mN·m				750mN·m				

Gear Ratio	1/30	1/50	1/60	2/125	1/75
Ordinary Torque	300mN·m				
Destruction Torque	900mN·m				

Gear Ratio	1/100	1/120	1/125	1/150	1/200	1/250	1/300
Ordinary Torque	400mN·m						
Destruction Torque	1200mN·m						

Torque Curve (pull-out torque)*

Bipolar Constant Voltage (48P1)

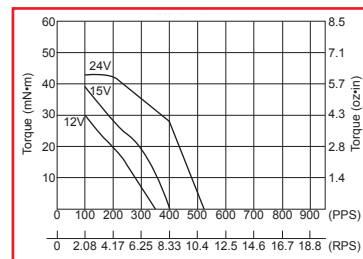

Coil Resistance: 76Ω

Bipolar Constant Current (48Y1)

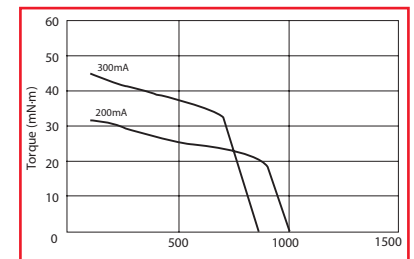

Coil Resistance: 20Ω Supply Voltage: 24V

Unipolar Constant Voltage (48C1)

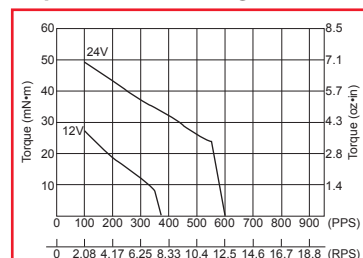

Coil Resistance: 70Ω

Unipolar Constant Current (48I1)

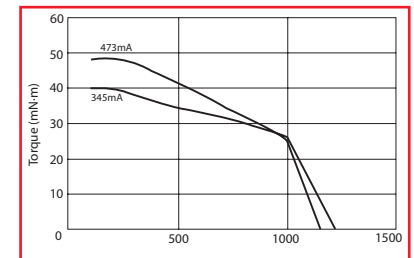

Coil Resistance: 20Ω Supply Voltage: 24V

All tin-can motor specifications are based on full-step constant voltage operation

Magnet type: Anisotropic

*Torque curves are for reference only and are not guaranteed

Sold & Serviced By:

ELECTROMATE

Toll Free Phone (877) SERV098

Toll Free Fax (877) SERV099

www.electromate.com

sales@electromate.com

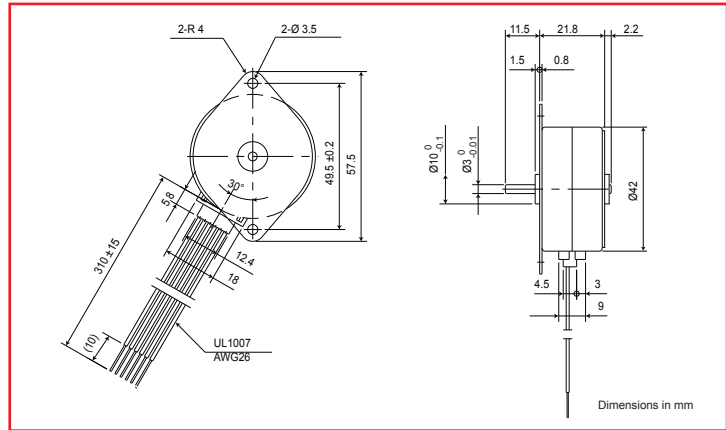
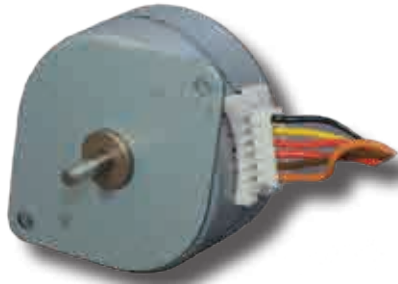

Specifications

Specification	Unit	PFC42H-48			
Type of Winding		Unipolar		Bipolar	
Excitation Mode*		Full step (2-2)			
Step Angle	°	7.5 ±5%			
Steps Per Revolution*		48			
Winding		C	D	P	Q
Rated Voltage	V	12	5	12	5
Resistance	Ω	70	12	70	12
Inductance	mH	39	6.6	80	13
Holding Torque	mN-m	50	50	70	70
Rotor Inertia	kg-m ²	27 x 10 ⁻⁷			
Starting Pulse Rate*	pps	290			
Slewing Pulse Rate*	pps	320			
Operating Temp. Range	°C	-10 to +50			
Temperature Rise*	K	55			
Weight	g	160			

Torque Curve (pull-out torque)*

Bipolar Constant Voltage (48P1)

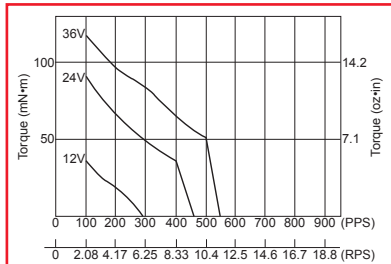

Coil Resistance: 70Ω

Bipolar Constant Current (48Q1)

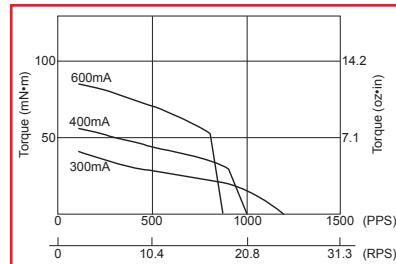

Coil Resistance: 12Ω Supply Voltage: 24V

Unipolar Constant Voltage (48C1)

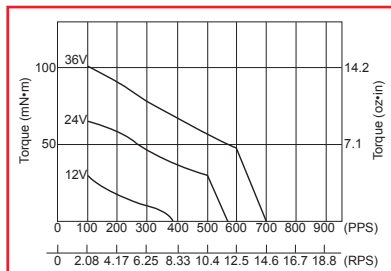

Coil Resistance: 70Ω

Unipolar Constant Current (48D1)

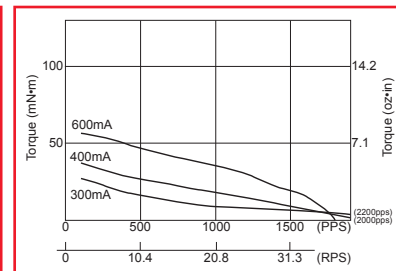

Coil Resistance: 12Ω Supply Voltage: 24V

All tin-can motor specifications are based on full-step constant voltage operation.

Magnet type: Anisotropic

*Torque curves are for reference only and are not guaranteed

Dimensions of Geared Model

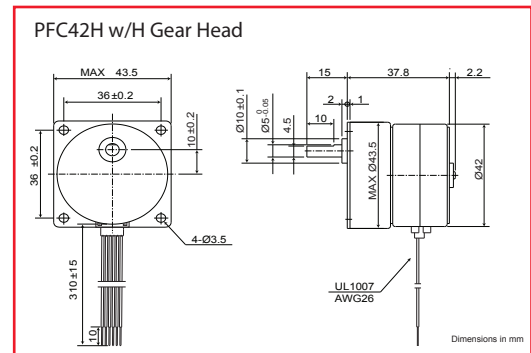

Gear Ratio	6/25	1/5	3/25	1/10	2/25	1/15	3/50	1/20	1/25
Ordinary Torque	200mN-m				250mN-m				
Destruction Torque	600mN-m				750mN-m				

Gear Ratio	1/30	1/50	1/60	2/125	1/75
Ordinary Torque	300mN-m				
Destruction Torque	900mN-m				

Gear Ratio	1/100	1/120	1/125	1/150	1/200	1/250	1/300
Ordinary Torque	400mN-m Sold & Serviced By:						
Destruction Torque	1200mN-m						

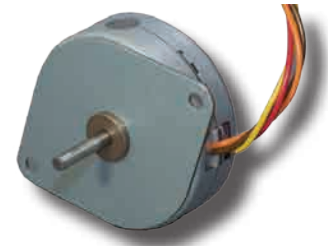
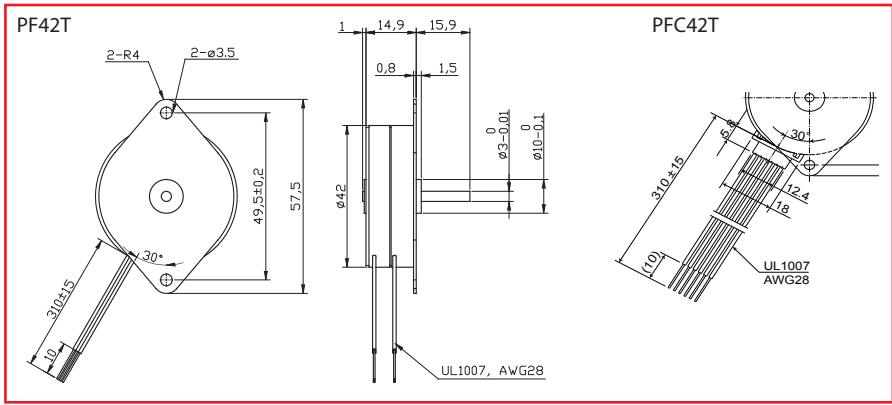

Specifications

Specification	Unit	PF(C)42T-48				PF(C)42T-96			
		Unipolar		Bipolar		Unipolar		Bipolar	
Type of Winding									
Excitation Mode*		Full step (2-2)				Full step (2-2)			
Step Angle	°	7.5 ±5%				3.75 ±5%			
Steps Per Revolution*		48				96			
Winding		C	D	P	Q	C	D	P	Q
Rated Voltage	V	12	5	12	5	12	5	12	5
Resistance	Ω	60	9.5	64	12	60	95	64	12
Inductance	mH	25	4	51	12	29	4.6	59	13
Holding Torque	mN·m	34	34	42	42	30	36	49	49
Rotor Inertia	kg·m ²	14.8 x 10 ⁻⁷				14.8 x 10 ⁻⁷			
Starting Pulse Rate*	pps	345				450			
Slewing Pulse Rate*	pps	550				590			
Operating Temp. Range	°C	-10 to +50							
Temperature Rise*	K	70							
Weight	g	105							

Dimensions of Geared Model

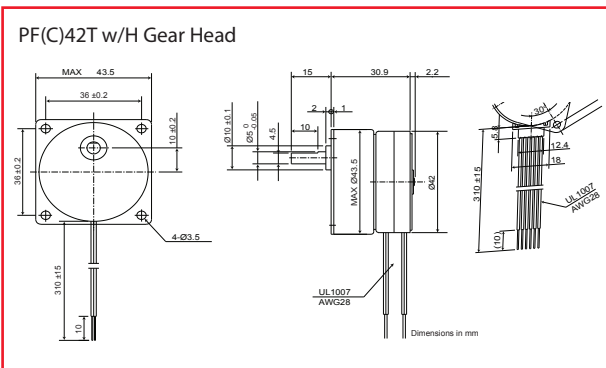

Torque Curve (pull-out torque)*

Bipolar Constant Voltage (48P1)

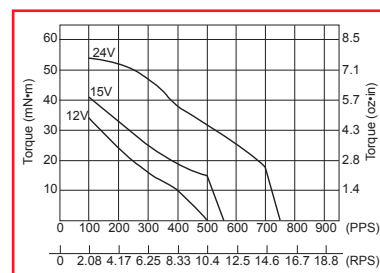

Coil Resistance: 64Ω

Bipolar Constant Current (48271)

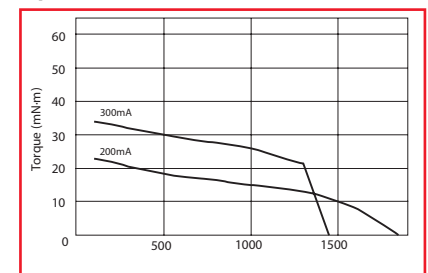

Coil Resistance: 19Ω Supply Voltage: 24V

Unipolar Constant Voltage (48C1)

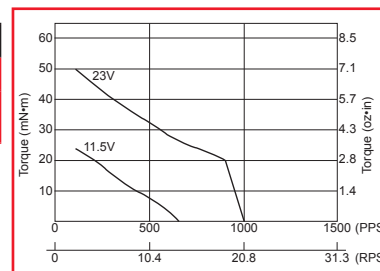

Coil Resistance: 60Ω

Unipolar Constant Current (48071)

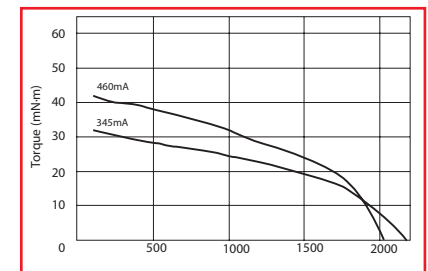

Coil Resistance: 20Ω Supply Voltage: 24V

Gear Ratio	6/25	1/5	3/25	1/10	2/25	1/15	3/50	1/20	1/25
Ordinary Torque	200mN·m				250mN·m				
Destruction Torque	600mN·m				750mN·m				

Gear Ratio	1/30	1/50	1/60	2/125	1/75
Ordinary Torque	300mN·m				
Destruction Torque	900mN·m				

Gear Ratio	1/100	1/120	1/125	1/150	1/200	1/250	1/300
Ordinary Torque	400mN·m						
Destruction Torque	1200mN·m						

All tin-can motor specifications are based on full-step constant voltage operation.

Magnet type: Anisotropic

*Torque curves are for reference only and are not guaranteed

Sold & Serviced By:



Toll Free Phone (877) SERV098
Toll Free Fax (877) SERV099
www.electromate.com
sales@electromate.com

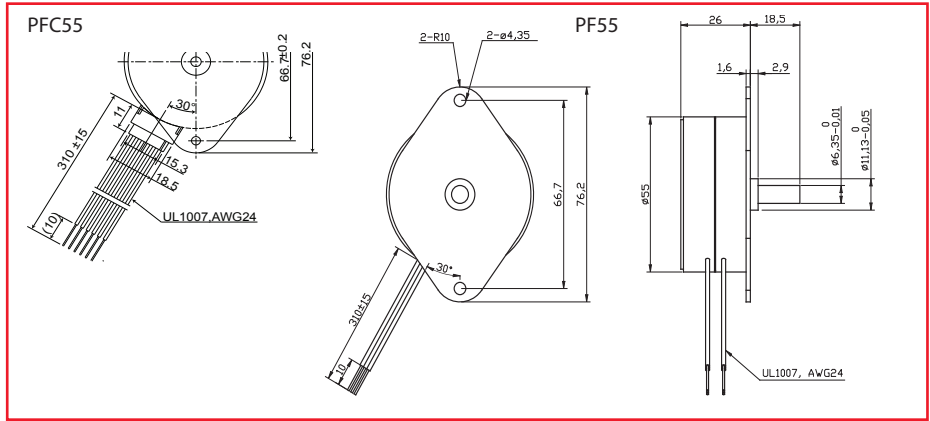
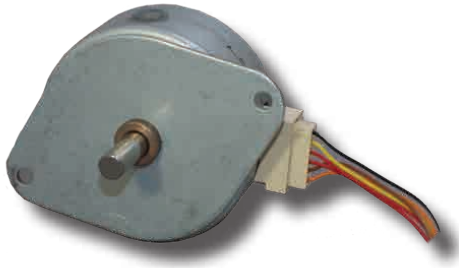

Specifications

Specification	Unit	PFC55-48			
Type of Winding		Unipolar		Bipolar	
Excitation Mode*		Full step (2-2)			
Step Angle	°	7.5 ±5%			
Steps Per Revolution*		48			
Winding		C	D	P	Q
Rated Voltage	V	12	5	12	5
Resistance	Ω	36	5	40	6.75
Inductance	mH	37	4.6	84	12
Holding Torque	mN·m	120	120	150	150
Rotor Inertia	kg·m ²	40 x 10 ⁻⁷			
Starting Pulse Rate*	pps	280			
Slewing Pulse Rate*	pps	300			
Operating Temp. Range	°C	-10 to +50			
Temperature Rise*	K	55			
Weight	g	300			

Dimensions of Geared Model

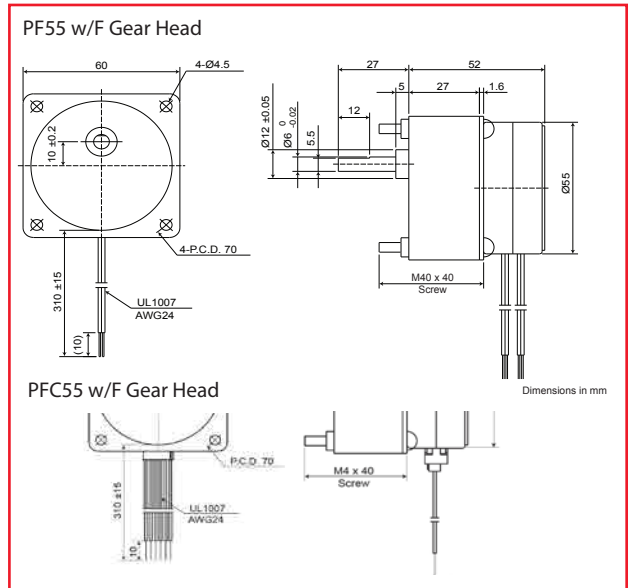

Torque Curve (pull-out torque)*

Bipolar Constant Voltage (48P1)

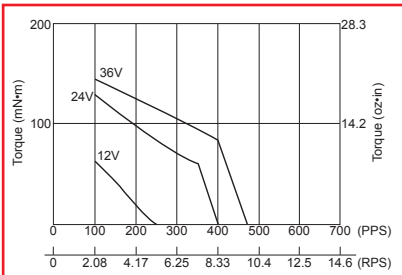

Coil Resistance: 40Ω

Bipolar Constant Current (48Q1)

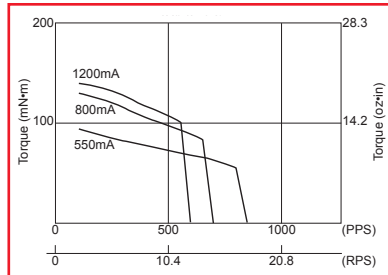

Coil Resistance: 6.75Ω Supply Voltage: 24V

Unipolar Constant Voltage (48C1)

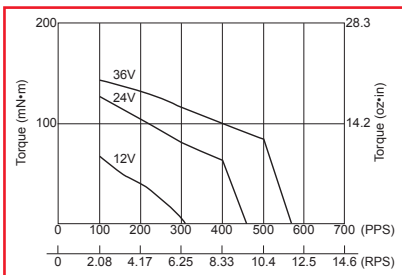

Coil Resistance: 36Ω

Unipolar Constant Current (48D1)

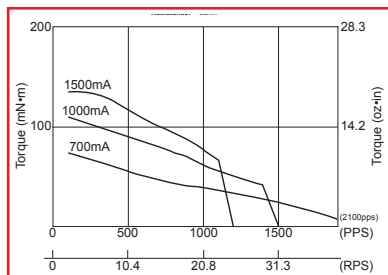

Coil Resistance: 5Ω Supply Voltage: 24V

All tin-can motor specifications are based on full-step constant voltage operation

Magnet type: Anisotropic

*Torque curves are for reference only and are not guaranteed

Gear Ratio	6/25	1/5	3/25	1/10	2/25	1/15	3/50	1/20
Ordinary Torque	400mN·m							
Destruction Torque	1200mN·m							

Gear Ratio	1/25	1/30	1/50	1/60
Ordinary Torque	700mN·m			
Destruction Torque	2100mN·m			

Gear Ratio	2/125	1/75	3/250	1/100	1/125	1/150	1/250	1/300
Ordinary Torque	1000mN·m							
Destruction Torque	3000mN·m							

Sold & Serviced By: **ELECTROMATE**

Toll-Free Phone: (877) SERV098
 www.electromate.com Fax: (817) SERV099
 www.electromate.com
 sales@electromate.com

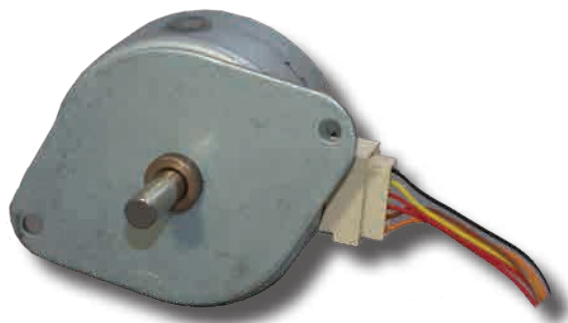
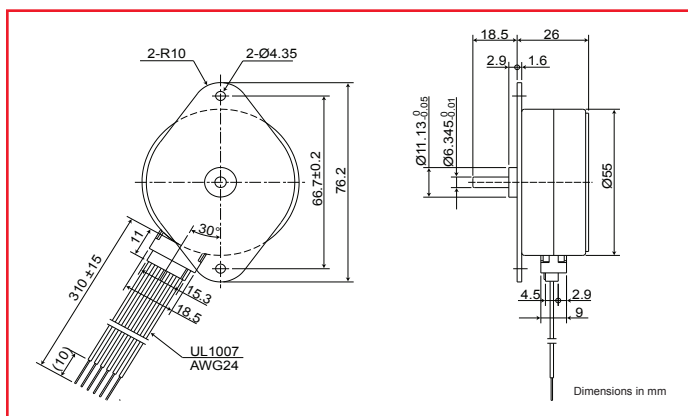

Specifications

Specification	Unit	PFC55H-48			
Type of Winding		Unipolar		Bipolar	
Excitation Mode*		Full step (2-2)			
Step Angle	°	7.5 ±5%			
Steps Per Revolution*		48			
Winding		C	D	P	Q
Rated Voltage	V	12	5	12	5
Resistance	Ω	36	5	36	5
Inductance	mH	30	4.4	65	9.3
Holding Torque	mN·m	150	150	180	180
Rotor Inertia	kg·m ²	97 x 10 ⁻⁷			
Starting Pulse Rate*	pps	210			
Slewing Pulse Rate*	pps	230			
Operating Temp. Range	°C	-10 to +50			
Temperature Rise*	°C	55			
Weight	g	300			

Torque Curve (pull-out torque)* Bipolar Constant Voltage (48011)

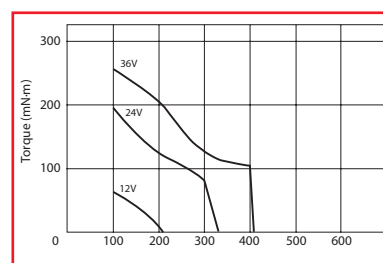

Coil Resistance: 40Ω

Bipolar Constant Current (48S1)

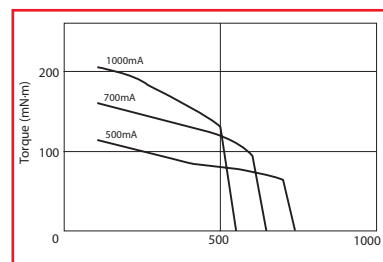

Coil Resistance: 8Ω Supply Voltage: 24V

Unipolar Constant Voltage (48C1)

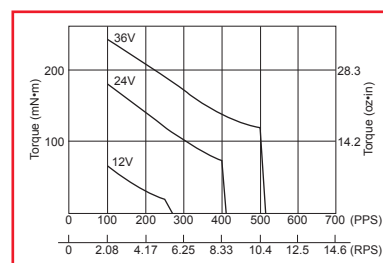

Coil Resistance: 36Ω

Unipolar Constant Current (48D1)

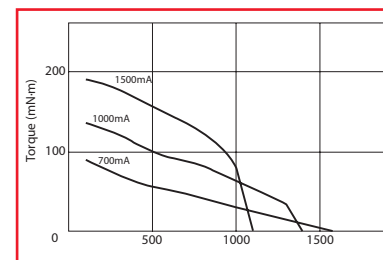

Coil Resistance: 5Ω Supply Voltage: 24V

Dimensions of Geared Model

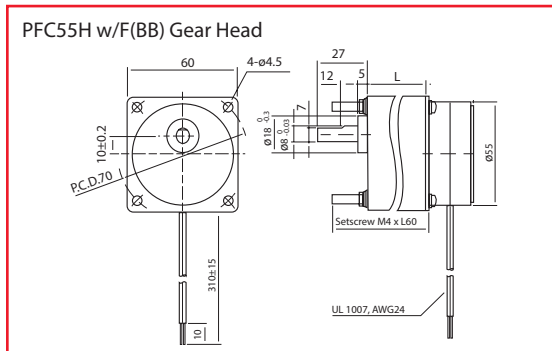

Gear Ratio	1/3	1/5	2/15	1/10	2/25	1/15	1/20
Ordinary Torque	400mN·m			500mN·m		600mN·m	800mN·m
Destruction Torque	1200mN·m			1500mN·m		1800mN·m	2400mN·m

Gear Ratio	1/25	1/30	1/50	1/60	Reduction Ratio	L
Ordinary Torque	900mN·m	1100mN·m	1600mN·m		1/3 to 1/15	32
Destruction Torque	2700mN·m	3300mN·m	4800mN·m		1/20 to 1/180	42

Gear Ratio	1/75	1/100	1/125	1/150	1/180
Ordinary Torque	2500mN·m				
Destruction Torque	7500mN·m				

See page 16 for PFC55H with F gearhead ratios

All tin-can motor specifications are based on full-step constant voltage operation
Magnet type: Anisotropic

*Torque curves are for reference only and are not guaranteed



PF25 w/P Gearhead

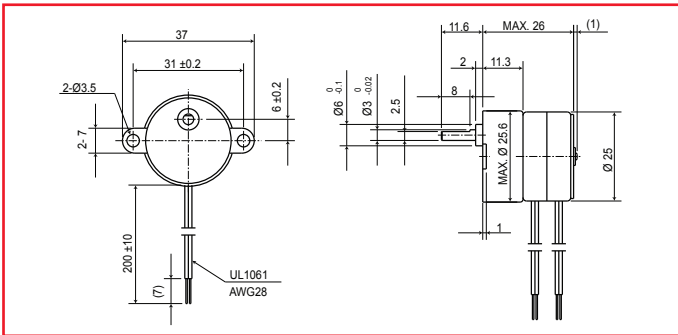

Gear Ratio	6/25	1/5	3/25	1/10	2/25	1/15	3/50	1/20
Ordinary Torque	20mN·m				50mN·m			

Gear Ratio	1/25	1/30	1/50	1/60	1/75	2/125
Ordinary Torque	70mN·m					

Gear Ratio	1/100	1/120	1/125	1/150	1/200	1/250	1/300
Ordinary Torque	100mN·m						

PF(C)42/42H/42T w/H Gearhead

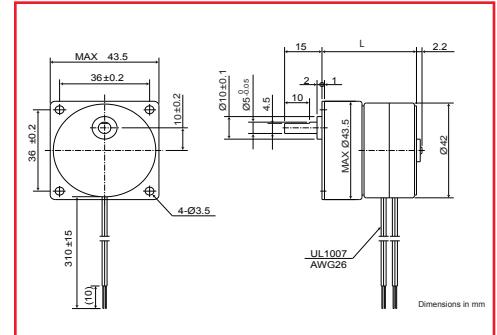

	L
PF42/ PFC42H	37.8
PF42T/ PFC42T	31

Gear Ratio	6/25	1/5	3/25	1/10	2/25	1/15	3/50	1/20	1/25
Ordinary Torque	200mN·m					250mN·m			

Gear Ratio	1/30	1/50	1/60	2/125	1/75
Ordinary Torque	300mN·m				

Gear Ratio	1/100	1/120	1/125	1/150	1/200	1/250	1/300
Ordinary Torque	400mN·m						

PF35/35T w/M Gearhead

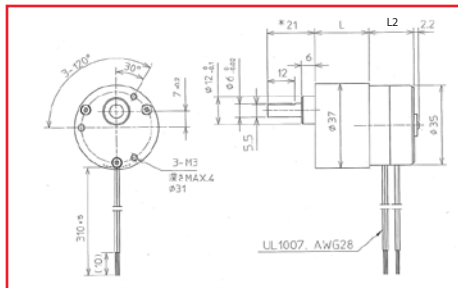

	L2
PF35	19.8
PF35T	14.2

see Page 13 for L specifications

Gear Ratio	1/5	1/6	1/10	1/12	1/15	1/18	1/25	1/30
Ordinary Torque	100mN·m				200mN·m			

Gear Ratio	1/40	1/50	1/60	1/75	1/90	1/100	1/120
Ordinary Torque	300mN·m						

Gear Ratio	1/125	1/150	1/180	1/200	1/250	1/300
Ordinary Torque	600mN·m					

PF(C)55/55H w/F Gearhead

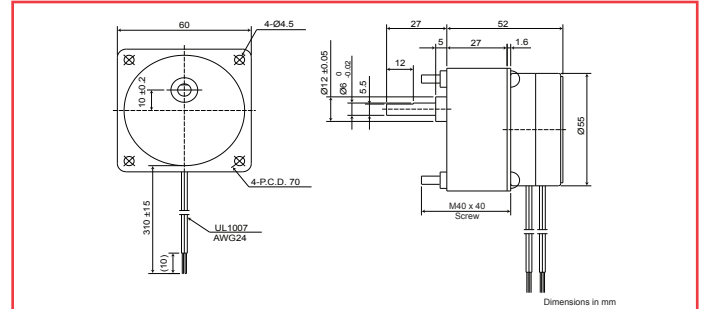

Gear Ratio	6/25	1/5	3/25	1/10	2/25	1/15	3/50	1/20
Ordinary Torque	400mN·m							

Gear Ratio	1/25	1/30	1/50	1/60
Ordinary Torque	700mN·m			

Gear Ratio	2/125	1/75	3/250	1/100	1/125	1/150	1/250	1/300
Ordinary Torque	1000mN·m							

PF35/35T w/H Gearhead

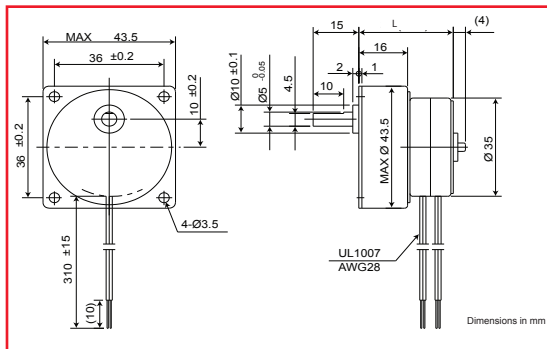

	L
PF35	36.6
PF35T	31

Gear Ratio	6/25	1/5	3/25	1/10	2/25	1/15	3/50	1/20	1/25
Ordinary Torque	200mN·m					250mN·m			

Gear Ratio	1/30	1/50	1/60	2/125	1/75
Ordinary Torque	300mN·m				

Gear Ratio	1/100	1/120	1/125	1/150	1/200	1/250	1/300
Ordinary Torque	400mN·m						

PF(C)55/55H w/F(BB) Gearhead

F(BB) gearhead provides ball-bearing support for all stages, ensuring long service life

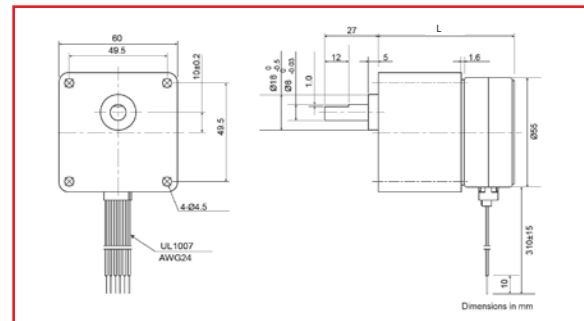

Gear Ratio	1/3	1/5	2/15	1/10	2/25	1/15	1/20
Ordinary Torque	400mN·m	500mN·m	600mN·m	800mN·m			

Gear Ratio	1/25	1/30	1/50	1/60
Ordinary Torque	900mN·m	1100mN·m	1600mN·m	

Gear Ratio	1/75	1/100	1/125	1/150	1/180
Ordinary Torque	2500mN·m				

Reduction Ratio	L
1/3 to 1/15	32
1/20 to 1/180	42

Sold & Serviced By: **ELECTROMATE**

Nippon Pulse LINEARSTEP® Motors

A tin-can linear actuator, the PFL series (LINEARSTEP®) is designed to provide a simple system at a fraction of the cost of a conventional rotary stepper motor. Offered in diameters of 25mm and 35mm, the LINEARSTEP® series can also be ordered with one of three pitches on the lead thread screw (0.48mm, 0.96mm, and 1.2mm). The LINEARSTEP® series comes with either a bipolar or unipolar winding.

Relationship Between Pulse Rate and Speed

When the thread pitch and the pulse rate change, the speed will also change.

48 steps/revolution

unit: mm/s

Thread Pitch (mm)	Pulse Rate (pps)						
	100	200	300	400	500	600	700
0.48	1	2	3	4	5	6	7
0.96	2	4	6	8	10	12	14
1.20	2.5	5.0	7.5	10	12.5	15	17.5

24 steps/revolution

unit: mm/s

Thread Pitch (mm)	Pulse Rate (pps)						
	100	200	300	400	500	600	700
0.48	2	4	6	8	10	12	14
0.96	4	8	12	16	20	24	28
1.20	5.0	10	15	20	25	30	35



PFL35T-48C4

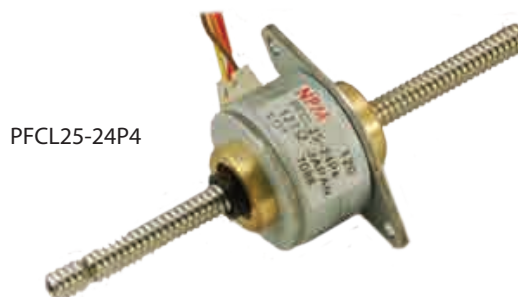

PFCL25-24P4

Model Number Explanation

PF(C)	L	25	T	-	48	Q	4	-	048	-	30
1	2	3	4		5	6	7		8		9

1 - Series Designation

PF: Standard
PFC: Connector

2 - LINEARSTEP® Designation

3 - Motor Diameter (mm)

25mm
35mm

4 - Thin stack

5 - Steps per Revolution

24: 15°/step
48: 7.5°/step

6 - Winding

C: 12V unipolar
D: 5V unipolar
P: 12V bipolar (PFCL25 only)
Q: 5V bipolar
R: 12V bipolar (PFL35T only)

7 - Magnet Material

4: Neodymium

8 - Thread Pitch

048: 0.48mm
096: 0.96mm
120: 1.20mm

9 - Shaft Stroke in mm

30: 30mm stroke, 60mm shaft
60: 60mm stroke, 90mm shaft

Additional winding options are available to meet your needs.

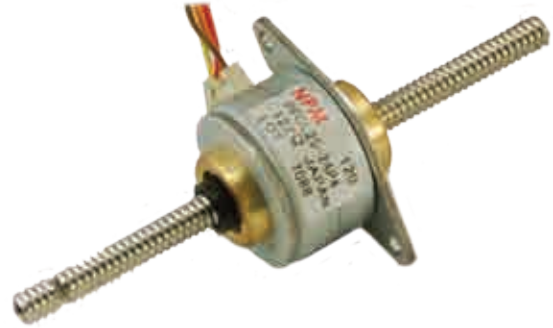
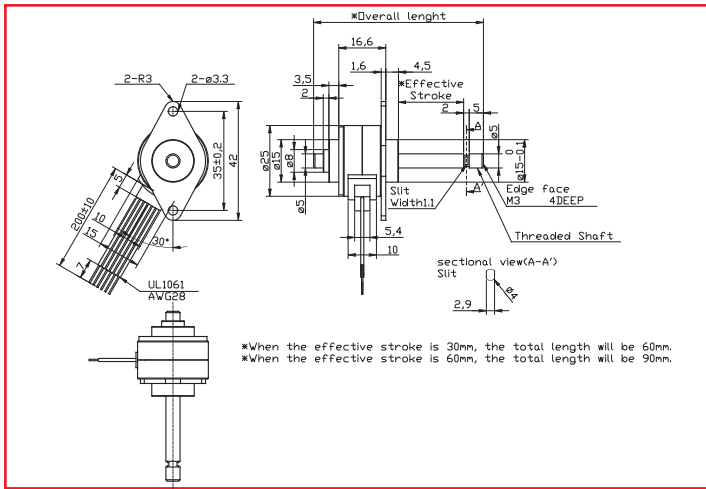

PFCL25-24														
Type Of Winding	Unipolar							Bipolar						
Steps Per Revolution*	24													
Thread Pitch	mm	0.48	0.96	1.2	0.48	0.96	1.2	0.48	0.96	1.2	0.48	0.96	1.2	
Travel/Step	mm	0.02	0.04	0.05	0.02	0.04	0.05	0.02	0.04	0.05	0.02	0.04	0.05	
Stroke	mm	30 or 60												
Force @ 200pps	N	11	9.5	8	11	9.5	8	16	14	11	16	14	11	
Rated Voltage	V	12			5				12			5		
Rated Current	A/Ø	0.10			0.31				0.10			0.30		
Resistance	Ω	120			16				122			15		
Inductance	mH/Ø	27			3.7				59			7.1		
Operating Temp. Range	°C	-10 to +50												
Temperature Rise*	°K	70												
Weight	g	60												

PFCL25-48														
Type Of Winding	Unipolar							Bipolar						
Steps Per Revolution	48													
Thread Pitch	mm	0.48	0.96	1.2	0.48	0.96	1.2	0.48	0.96	1.2	0.48	0.96	1.2	
Travel/Step	mm	0.01	0.02	0.025	0.01	0.02	0.025	0.01	0.02	0.025	0.01	0.02	0.025	
Stroke	mm	30 or 60												
Force @ 200 pps	N	22	17.5	15	22	17.5	15	31	22.5	20.5	31	22.5	20.5	
Rated Voltage	V	12			5				12			5		
Rated Current	A/Ø	0.10			0.31				0.10			0.33		
Resistance	Ω	120			16				122			15		
Inductance	mH/Ø	33			4.5				73			8.7		
Operating Temp. Range	°C	-10 to +50												
Temperature Rise	°K	70												
Weight	g	60												

Unipolar Constant Voltage 24C4 Torque Curve

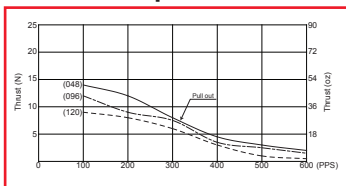

Unipolar Constant Voltage 48C4 Torque Curve

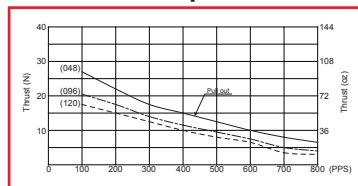

Bipolar Constant Voltage 24P4 Torque Curve

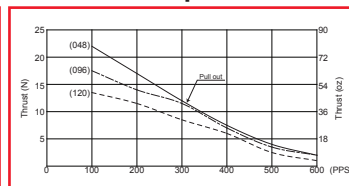

Bipolar Constant Voltage 48P4 Torque Curve

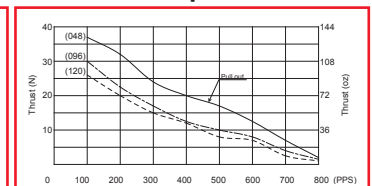

All tin-can motor specifications are based on full-step constant voltage operation
Magnet type: Neodymium
Torque curves are for reference only and are not guaranteed.

Sold & Serviced By:
ELECTROMATE

Toll-Free Phone (977) SERV098
www.electromate.com
sales@electromate.com

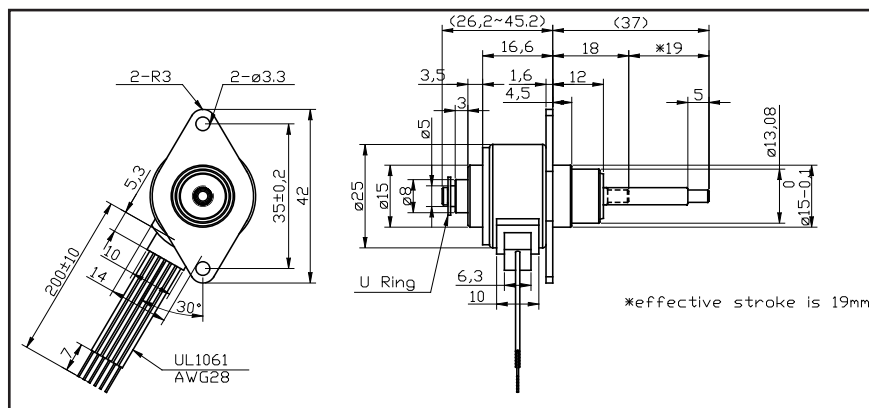

		PFCL25-48 w/ Captive			
		Unipolar		Bipolar	
Type Of Winding					
Steps Per Revolution		48			
Thread Pitch	mm	0.48			
Travel/Step	mm	0.01			
Stroke	mm	19			
Rated Voltage	V	12	5	12	5
Rated Current	A/Ø	0.10	0.31	0.10	0.30
Resistance	Ω	120	16	122	15
Inductance	mH/Ø	33	4.5	73	8.7
Operating Temp. Range	$^{\circ}$ C	-10 to +50			
Temperature Rise	$^{\circ}$ K	70			
Weight	g	60			

PFCL25-48x4-C
Unipolar Constant Voltage

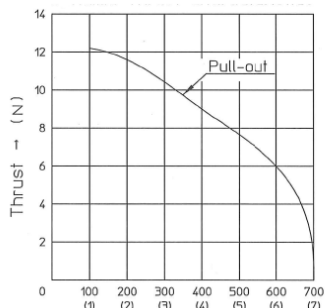

PFCL25-48x4-C
Bipolar Constant Voltage Drive

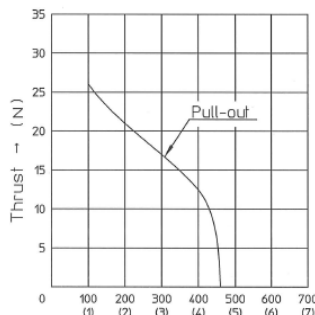

All tin-can motor specifications are based on full-step constant voltage operation.

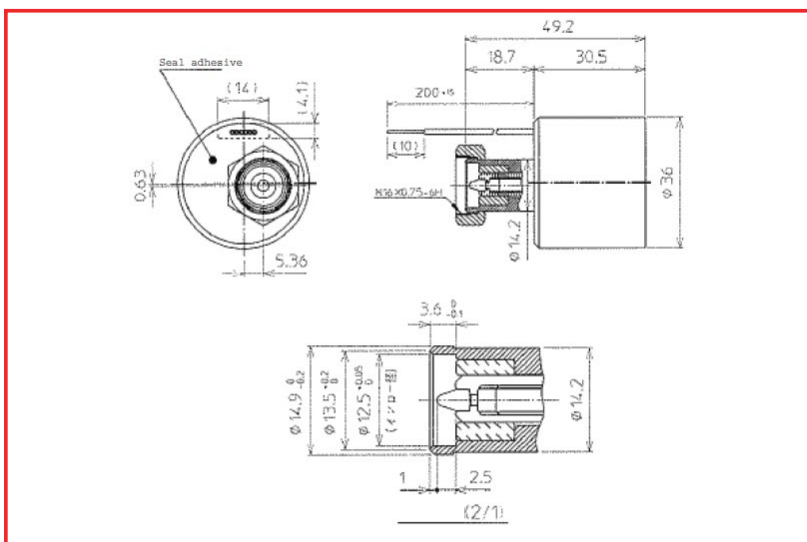
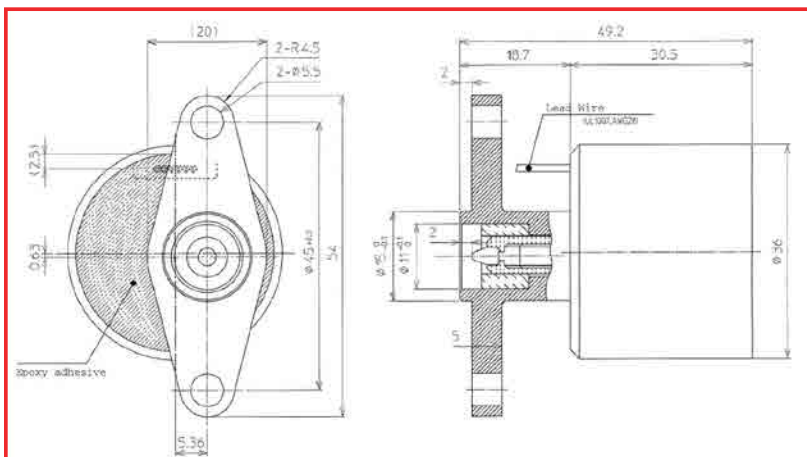

NFC Linear Actuator Features

- Linear actuator with PM-type geared stepper and feed screw
- Unique captive structure and torque transmission structure achieve high performance and high resolution
- Since the shaft output does not rotate, it will not create friction on the part it is connected with

NFC Linear Actuator Applications

- Valve and pump control
- Control for precision linear devices

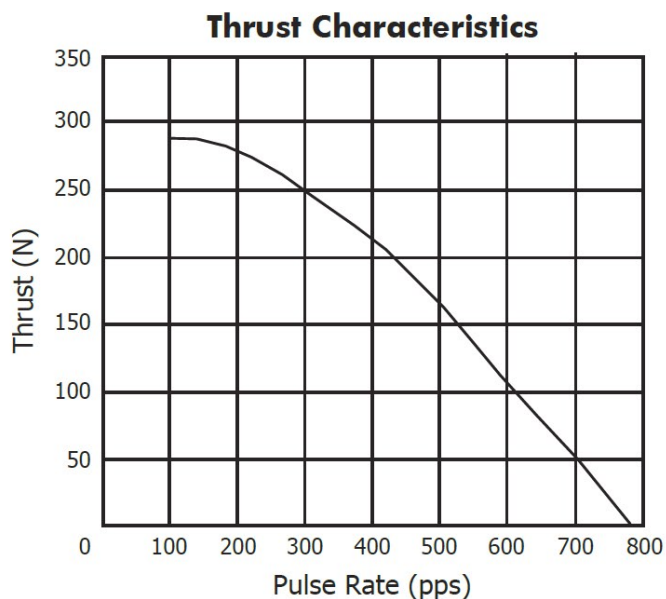

Specifications	Unit	NFC
Type of Winding		
Excitation Mode		2-2
Thrust	N	300
Resolution	mm/step	0.000347
Stroke	mm	10 (max.)
Rating		IP67
Resistance	Ω	200
Inductance	mH	57
Dielectric Strength	VAC	1000
Insulation Resistance	M Ω	100
Starting Pulse Rate	pps	550
Slewing Pulse Rate	pps	780
Max. Operating Temp.	$^{\circ}\text{C}$	+100
Ambient Temp. Range	$^{\circ}\text{C}$	-30~+80
Operating Temp. Range	$^{\circ}\text{C}$	-10~+65
Temperature Rise	K	45
Insulation Class		E
Weight	g	125

PJP Series Two-Phase Hybrid Stepper Motors

Nippon Pulse's PJP Series motor is ideal for motion control applications where the benefits of smaller size with high torque are essential. They feature superior response characteristics and function in a wide variety of applications.



Features:

- PJP28 = NEMA 11
- PJP42= NEMA 17
- PJP56 = NEMA 23

Applications:

- Automation
- Document processing
- Printer, copiers and sorters
- Chart recorders and plotters
- Rotary positioning
- Robot grippers

General Specifications (Unipolar Winding*)

Specification	Unit	PJP28T				PJP42T			PJP56T					
		32E16	40E16	45E16	51E16	34D16	40D16	49D16	44A16	44B16	55A16	55B16	78A16	78B16
Excitation Mode		2-2 phase												
Step Angle	°	1.8												
Step Angle Tolerance	%	±5												
Steps Per Revolution		200												
Rated Voltage	V	2.66	3.23	3.71	4.37	2.9	3.6	4.0	2.8	5.7	3.6	7.4	4.5	8.6
Rated Current	A / ϕ	0.95				1.2			2.0	1.0	2.0	1.0	2.0	1.0
Resistance	Ω	2.8	3.4	3.9	4.6	2.4	3.0	3.3	1.4	5.7	1.8	7.4	2.25	8.6
Inductance	mH / ϕ	1.2	1.8	1.7	2.0	2.7	2.8	4.0	1.5	5.6	3.3	15.0	4.1	15.2
Max. Holding Torque	N · m	0.045	0.06	0.075	0.09	0.21	0.25	0.37	0.4	0.4	0.85	0.85	1.3	1.35
Rotor Inertia	×10 ⁻⁷ kg·m ²	9	12	14	17	36	56	74	120		280		480	
Operating Temp.	°C	-10 ~ +60												
Insulation Class		Class B (allowable coil temperature)												
Insulation Resistance	MΩ	100Ω												
Dielectric Strength	ACV	500V (1 min.)												
Mass	g	110	150	170	195	240	300	400	470		700		1000	

Part Numbering

PJP 42 T 34 D 1 6
 1 2 3 4 5 6 7

- 1: Series
- 2: Size
- 3: Design version
- 4: Stack length

- 5: Winding
- 6: Shaft (1, 2)
- 7: Leads
- 8: Customization (xx)



Pull-Out Torque

Drive Condition: 24V, 2-2 ϕ
 Driver: BCD4020UT (Unipolar Rated Current)

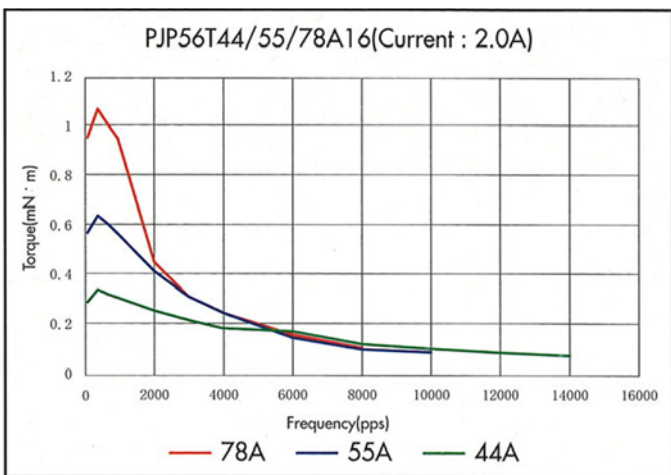
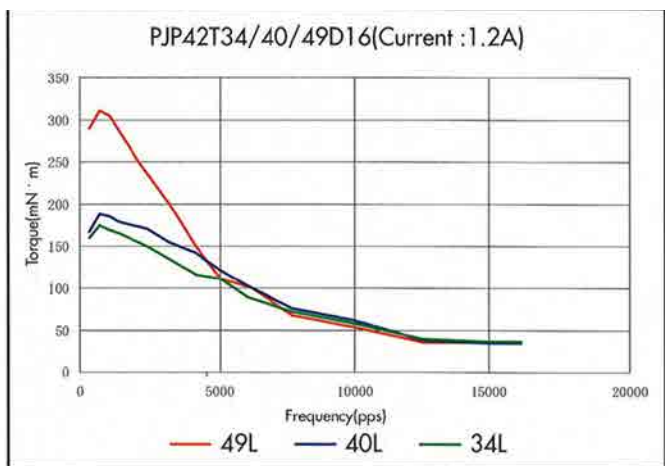
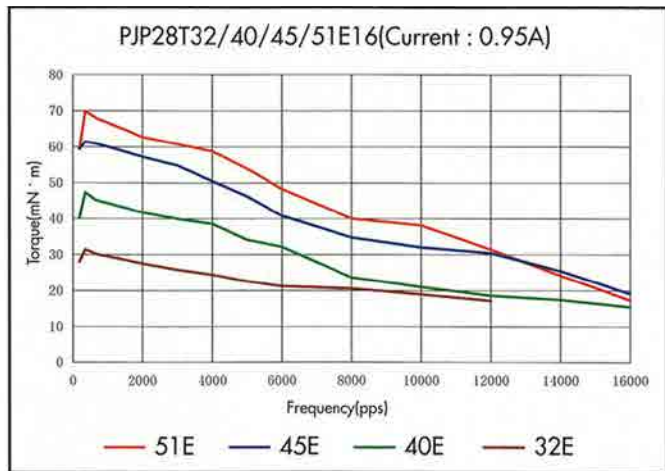

Dimensions (mm)

Double shaft options are available by request.

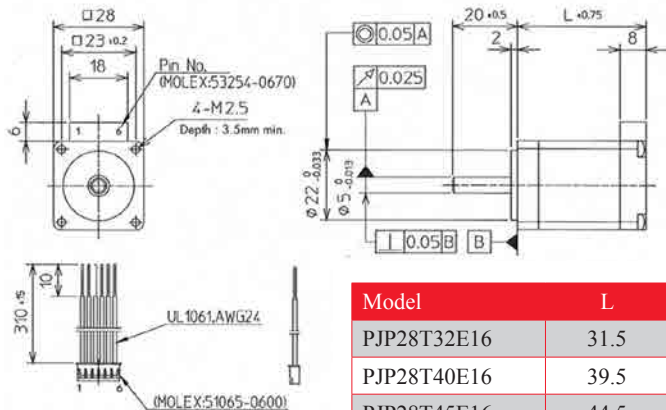

Model	L
PJP28T32E16	31.5
PJP28T40E16	39.5
PJP28T45E16	44.5
PJP28T51E16	50.5

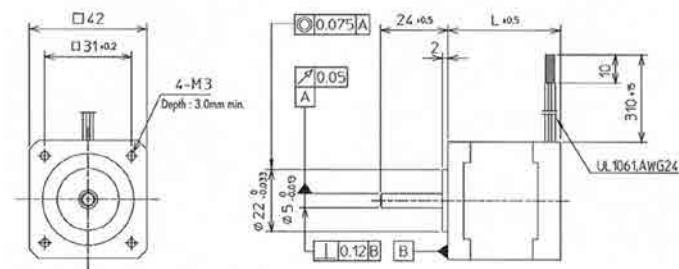

Model	L
PJP42T34D16	34
PJP42T40D16	40
PJP42T49D16	49

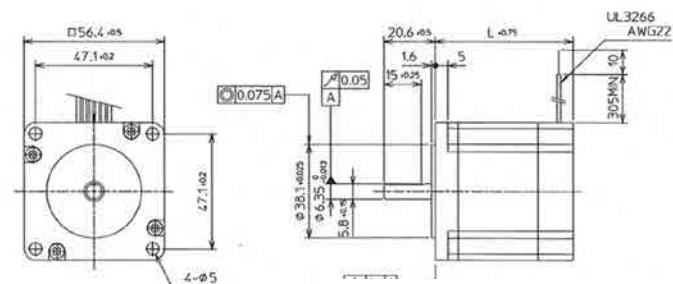

Model	L
PJP56T44A16	43.5
PJP56T55A16	55
PJP56T78A16	77.5

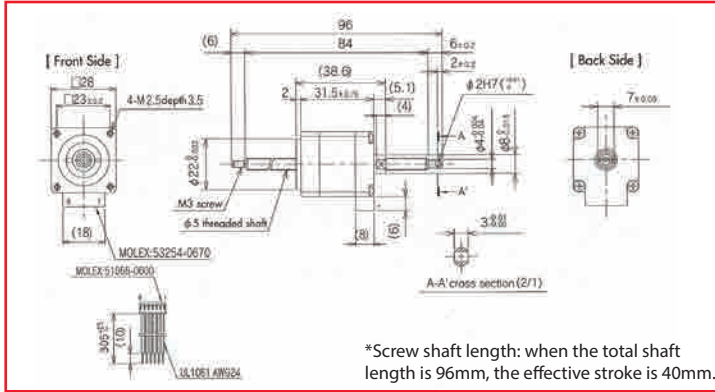

Nippon Pulse's PJPL Series motor is ideal for motion control applications where the benefits of smaller size with high force are essential. They feature superior response characteristics and function in a wide variety of applications.

Features:

- NEMA 11 and 17 mount face
- Includes integral lead screw for linear motion

Applications:

- Microscope Stage
- Syringe – Dispenser
- Cameras – Pan & Tilt
- Medical Scanners
- Laboratory Sample Handling

Specifications

Specification	Unit	PJPL2832E6(100)	PJPL2832E4 (100)
Type of Winding		Unipolar	Bipolar
Excitation Mode*		Full step (2-2)	
Resolution (travel/step)	mm	0.005	
Steps Per Revolution*		200	
Stroke	mm	40	
Rated Voltage	V	2.66	2.57
Rated Current	A/φ	0.95	
Resistance	Ω	2.8	2.7
Inductance	mH/φ	1.2	2.1
Operating Temp.	°C	-10~+50	
Insulation Class		B	
Insulation Resistance	MΩ	100	
Dielectric Strength	AC V	500V (1 min.)	
Weight	g	110	

Thrust Force

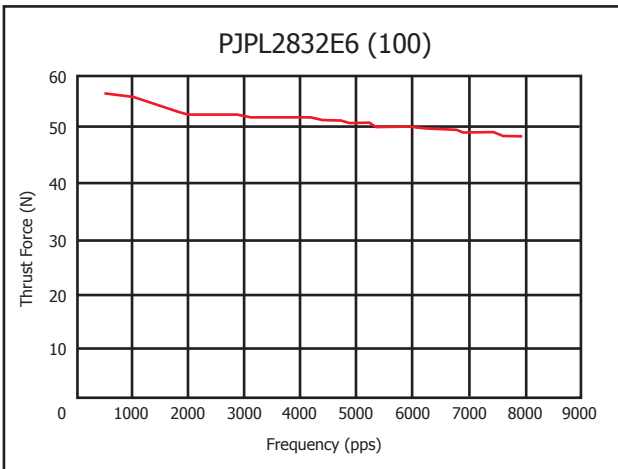

Frequency (pps)	Speed (mm/sec)
100	0.5
200	1.0
300	1.5
400	2.0
500	2.5
1000	5.0
2000	10.0
3000	15.0
4000	20.0
5000	25.0

	Lead Color	
	Unipolar	Bipolar
1	Black	Black
2	Yellow	
3	Green	Green
4	Blue	Blue
5	White	
6	Red	Red

Drive Settings
 Rated Current: 0.95A
 Winding Resistance: 2.8Ω
 Resolution: 5μm
 Drive Mode: Rated Current
 Drive Condition: 24V, 2-2

Part Numbering

PJPL 28 32 E 6 (100) -xx	1: Series Designation	5: Lead wires (6 or 4)
1 2 3 4 5 6 7	2: Motor Size (28mm, 42mm)	6: Thread Pitch (100=1mm)
	3: Case Length (32=31.5mm, 33=33mm)	7: Custom Motor Indicator
	4: Winding (A: 2A; B: 1A; C: 0.5A; D: 1.2A; E: 0.95A)	

Sold & Serviced By: **ELECTROMATE**

Toll Free Phone (977) SERV098
 NIPPONPULSE.COM TEL: (977) SERV099
 www.electromate.com
 sales@electromate.com

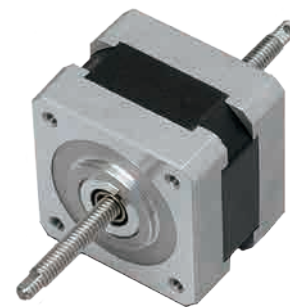
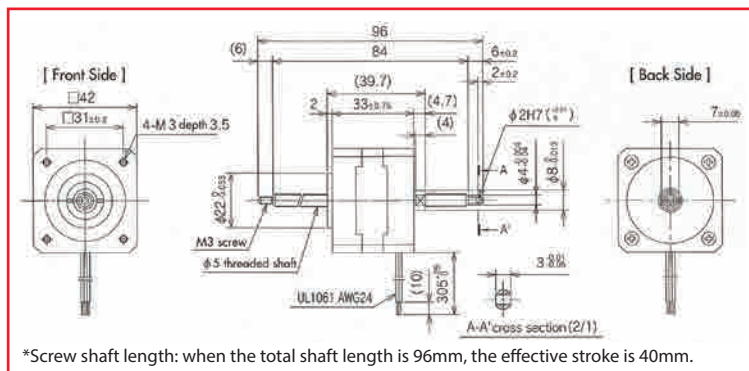

Specifications

Specification	Unit	PJPL4233D6(100)	PJPL4233D4 (100)
Type of Winding		Unipolar	Bipolar
Excitation Mode*		Full step (2-2)	
Resolution (travel/step)	mm	0.005	
Steps Per Revolution*		200	
Stroke	mm	40	
Rated Voltage	V	2.8	2.5
Rated Current	A/φ	1.2	
Resistance	Ω	2.3	2.1
Inductance	mH/φ	2.1	3.0
Operating Temp.	°C	-10~+50	
Insulation Class		B	
Insulation Resistance	MΩ	100	
Dielectric Strength	AC V	500V (1 min.)	
Weight	g	200	

Thrust Force

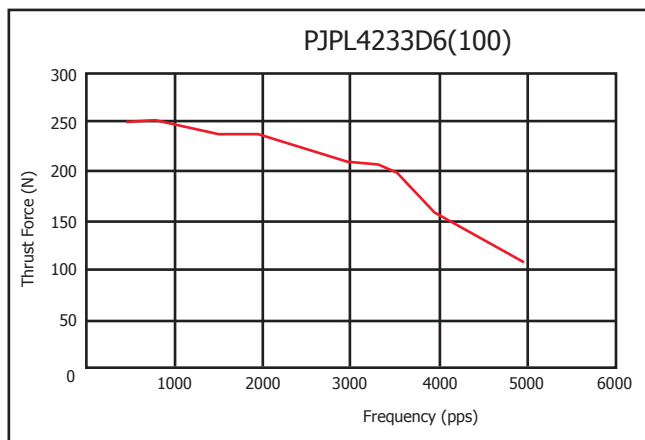

Frequency (pps)	Speed (mm/sec)
100	0.5
200	1.0
300	1.5
400	2.0
500	2.5
1000	5.0
2000	10.0
3000	15.0
4000	20.0
5000	25.0

	Lead Color	
	Unipolar	Bipolar
1	Black	Black
2	Yellow	
3	Green	Green
4	Blue	Blue
5	White	
6	Red	Red

Drive Settings

Rated Current: 1.2A
 Winding Resistance: 2.3Ω
 Resolution: 5μm
 Drive Mode: Rated Current
 Drive Condition: 24V, 2-2

Part Numbering

PJPL	42	33	D	6	(100)	-xx	1: Series Designation	5: Lead wires (6 or 4)
1	2	3	4	5	6	7	2: Motor Size (28mm, 42mm)	6: Thread Pitch (100=1mm)
							3: Case Length (32=31.5mm, 33=33mm)	7: Custom Motor Indicator
							4: Winding (A: 2A; B: 1A; C: 0.5A; D: 1.2A; E: 0.95A)	

Nippon Pulse's PJPLT Series motor is a low-friction, high-efficiency motor that works quickly. They feature built-in ball screws and function in a wide variety of applications.

PJPLT Series Features:

- Compact cylinder with 2-phase hollow stepper with built-in ball screw
- Multiple types of screw shafts and lead combinations available
- Two motor sizes: 28mm and 42mm
- Anti-rotational options available



PJPL28T Dimensions

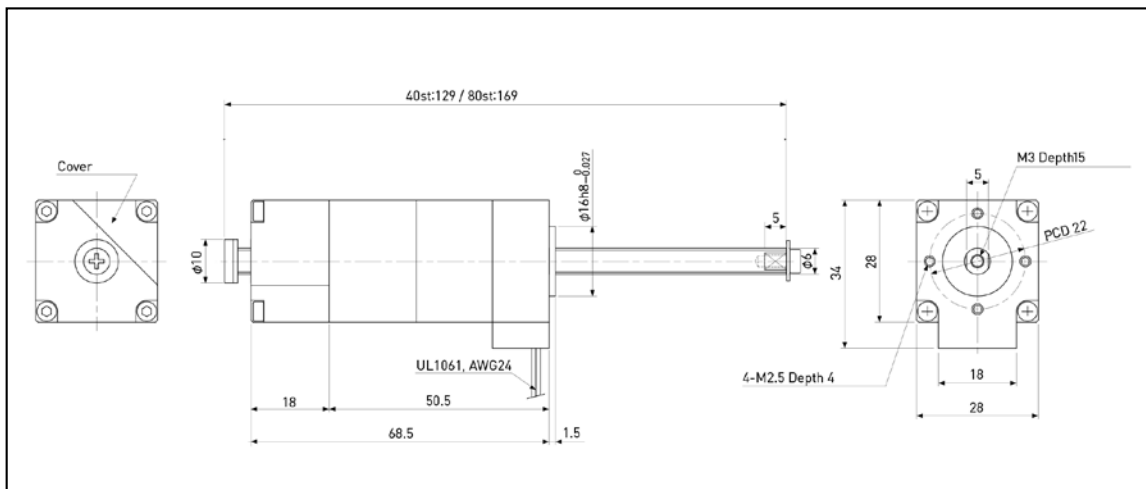

Specifications

Specification	Unit	PJPL28T	
Thread Pitch Options	mm	1	2
Travel/Step	μm	5	10
Repeatability	mm	±0.010	
Lost Motion	mm	0.020	
Stroke	mm	40/80	
Excitation		2-2	
Winding		Bipolar	
Rated Voltage	V	3.8	
Rated Current	A / φ	0.67	
Resistance	Ω	5.6	
Temperature Rise	K	75	
Thrust	N	50	25
Operating Temperature	°C	-10 ~ +50	
Insulation Resistance	MΩ	100	
Dielectric Strength	AC V	AC500V (1 min)	
Insulation Class		B	

	Lead Color	
	Unipolar	Bipolar
1	Black	Black
2	Yellow	
3	Green	Green
4	Blue	Blue
5	White	
6	Red	Red

Part Numbering

PJPL 42 T 73 D 4 A XXX R
 1 2 3 4 5 6 7 8

- 1: Series Designation
- 2: Motor size (28mm or 42mm)
- 3: Motor length (in mm)
- 4: Winding
- 5: # of lead wires
- 6: Full threaded shaft
- 7: Pitch
- 8: Rolled ball screw

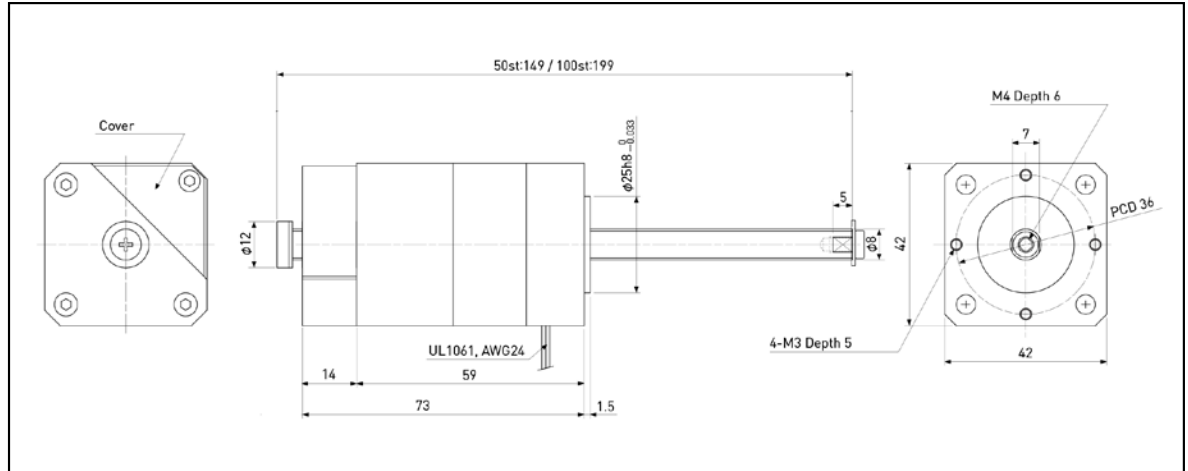

Specifications

Specification	Unit	PJPL42T	
Thread Pitch Options	mm	1	2
Travel/Step	μm	5	10
Repeatability	mm	± 0.010	
Lost Motion	mm	0.020	
Stroke	mm	50/100	
Excitation		2-2	
Winding		Bipolar	
Rated Voltage	V	2.5	
Rated Current	A / ϕ	1.2	
Resistance	Ω	2.1	
Temperature Rise	K	70	
Thrust	N	80	
Operating Temperature	$^{\circ}\text{C}$	-10 ~ +50	
Insulation Resistance	M Ω	100	
Dielectric Strength	AC V	AC500V (1 min)	
Insulation Class		B	

	Lead Color	
	Unipolar	Bipolar
1	Black	Black
2	Yellow	
3	Green	Green
4	Blue	Blue
5	White	
6	Red	Red

About Nippon Pulse Synchronous Motors

No Power or Load Fluctuation Effect

Synchronous motors rotate in synch with supplied power frequency. If power frequency is constant, the motor will rotate at a constant speed (synchronized speed).

Impedance Protected

Unless otherwise stated, these motors provide high electrical resistance, which prevents overcurrent from flowing to the motor, which would in turn burn the coils.

No Control Circuit Required

Because these motors are AC motors, they start rotating when a power connection is made.

Excellent Response

The type of magnet used in these motors ensures excellent response and also ensures the motor will start and stop immediately when power is supplied or removed.

Dual Direction Synchronous Motors

Motors that move in two directions are capacitor-based phase advancing motors. Because the rotor is moved by shifting the phase current by 90° it is essential for the circuit to have a capacitor. The proper wiring is below.

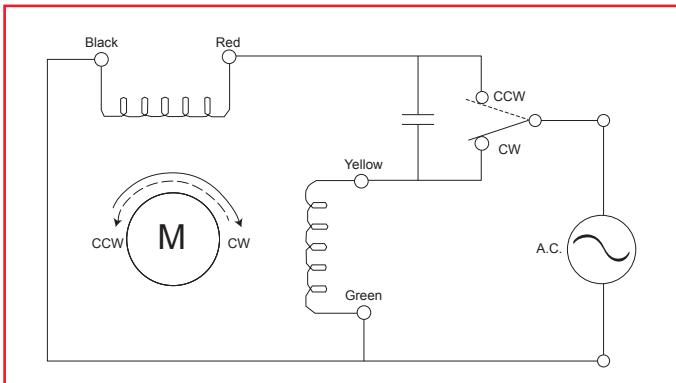

As viewed from the output shaft of the motor

Single Direction Synchronous Motor

Motors that are driven in just one direction, whether clockwise or counterclockwise, do not require any specific wiring to the AC power supply. A wiring diagram is below. The leadwires have no polarity.

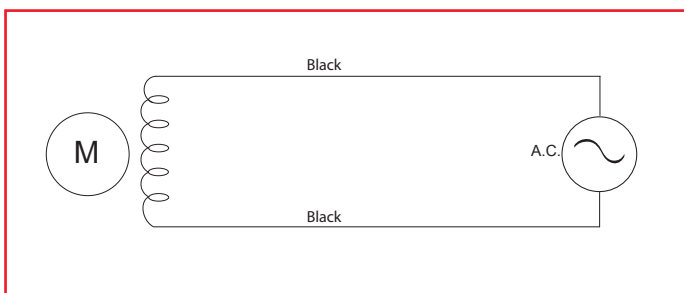

Dual Direction Synchronous Motors

PTM(C) -	24	F	3	4	G	1/2	
	1	2	3	4	5	6	7

1 - Series Designation

PTM: Flying lead joint type
PTMC: Connector joint type

2 - Number of Poles

12: Speed is 500 rpm w/50Hz
Speed is 600 rpm w/60Hz
24: Speed is 250 rpm w/50Hz
Speed is 300 rpm w/60Hz

3 - Outer Diameter (Type)

P: 25mm, M: 35mm, T: 35mm (thin), H: 42mm, S: 42mm (thin), F: 55mm, R: 55mm (w/ connector)

4 - Winding

Blank: Standard Coil
(continuous for 24, 100, 200 Vac)
1-18: Coil # for specific rating

5 - Magnet Type

Blank: Anisotropic
3: Isotropic
4: Neodymium
5: Plastic

6 - Gear Head

Blank: No Gear Head
G: Gear Head Integrated

7 - Gear Ratio

see chart with each motor page

Gear Ratio	rpm w/ 12 poles		rpm w/ 24 poles	
	50Hz	60Hz	50Hz	60 Hz
Motor only	500	600	250	300
1/10	50	60	25	30
1/50	10	12	5	6
1/100	5	6	2.5	3

Single Direction Synchronous Motors

PTM - 24	B	(G II)	100 - 50/60	- 2/2.4	CW			
1	2	3	4	5	6	7	8	9

1 - Series Designation

PTM: Flying lead joint

2 - Number of Poles

12: Speed is 500rpm w/50Hz
Speed is 600rpm w/60Hz
24: Speed is 250rpm w/50Hz
Speed is 300rpm w/60Hz

3 - Outer Diameter

B: 35mm
K: 42mm
E: 42mm (high output torque)

4 - Gear Head

Blank: No gear head
G: Gear head integrated

5 - PTM-24BGII only

Denotes BG gear type II

6 - Supply Voltage

24, 100, 200 Vac
voltage depends on model

7 - Power Frequency

50, 60, or 50/60Hz

8 - Rotating Speed

See available speeds with each motor

9 - Direction

CW - Clockwise
CCW - Counterclockwise

Line frequency of 60Hz makes the motor speed 1.2 times higher than 50Hz

Capacitor

With reversible synchronous motors (can rotate both clockwise and counterclockwise) the rotor is moved by shifting the phase by 90 degrees. Thus, a synchronous motor requires a capacitor, which should withstand a voltage of greater than twice the rated voltage of the motor.

Sold & Serviced By:

ELECTROMATE

Toll Free Phone: (877) SERV098
Fax: (831) SERV099
www.electromate.com
sales@electromate.com

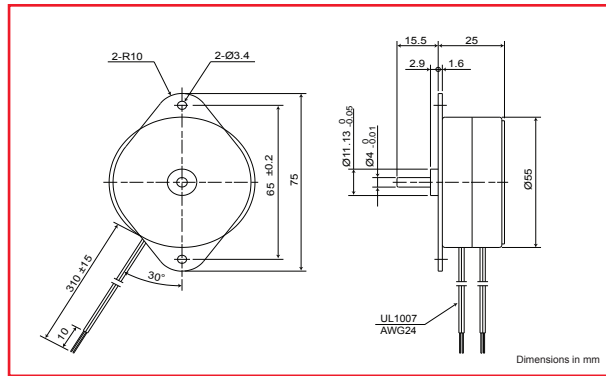

Specifications

Specifications	Units	PTM-24F		
Rated Voltage	V	24	100	200
Frequency	Hz	50/60		
Rated Current	mA	150/160	35/45	30/25
Revolutions	rpm	250/300		
Rotating Direction		Dual Direction (CW/CCW)		
Torque @ 60Hz	mN-m	35/30		
Temperature Rise	K	55		
Operating Temp. Range	°C	-10 to +50		
Dielectric Strength	V	500Vac for 1 min.	1000Vac for 1 min.	1500Vac for 1 min.
Weight	g	300		
Capacitor	µF	6.8	0.47	0.11

Magnet type: Anisotropic

Geared Models

PTM-24FG

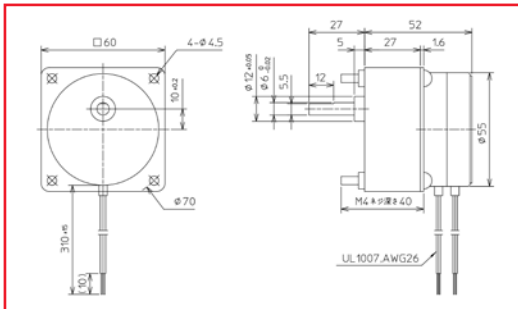

Gear Ratio	L
1/3 ~ 1/8	32
1/20 ~ 1/180	42

PTM-24FG(BB)

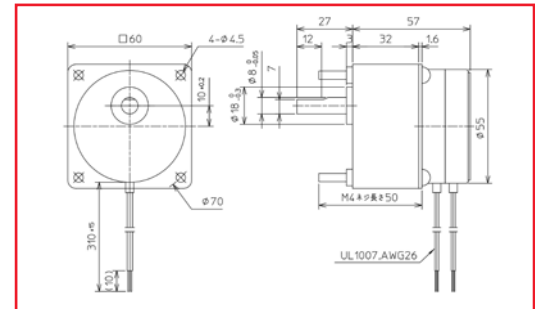

Geared Motor Torque Characteristics

Model	PTM-24FG			
	Torque (mN-m)		Gear Ratio	
	50Hz	60Hz	50Hz	60Hz
60	93	95	6/25	1/5
30	185	190	3/25	1/10
20	280	285	2/25	1/15
10	445	460	1/25	1/30
5	700*	700*	1/50	1/60
4	895	920	2/125	1/75
3	1000*	1000*	3/250	1/100
2	1000*	1000*	1/125	1/150
1	1000*	1000*	1/250	1/300

Values regulated by normal gear strength. Do not apply any load exceeding the normal gear strength.

Model	PTM-24FG(BB)			
	Torque (mN-m)		Gear Ratio	
	50Hz	60Hz	50Hz	60Hz
60	--	96	--	1/5
30	--	190	--	1/10
20	280	285	2/25	1/15
10	445	460	1/25	1/30
5	895	920	1/50	1/60
4	--	970	--	1/75
3	1150	1200	3/250	1/100
2	1750	1800	1/125	1/150
1	--	--	--	--

Sold & Serviced By: **ELECTROMATE**

Toll Free Phone (877) SERV098
Toll Free Fax (877) SERV099
www.electromate.com
sales@electromate.com

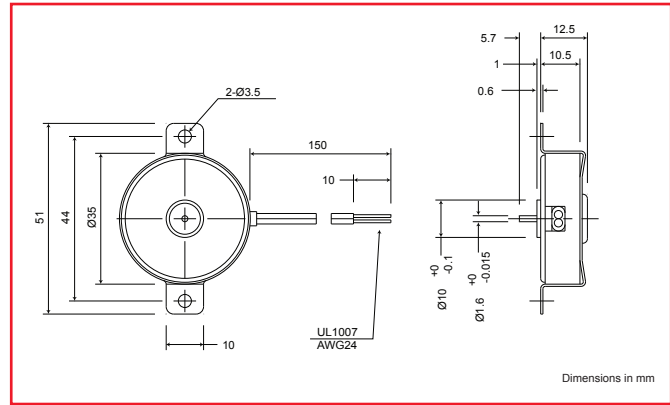

Specifications

Specifications	Units	PTM-24B			
Rated Voltage	V	12	24	100	200
Frequency	Hz	50/60			
Rated Current	mA	75/70	35/32	11/10	7/6.5
Revolutions	rpm	250/300			
Rotating Direction		Single Direction (CW/CCW)			
Torque @ 60Hz	mN-m	0.5			
Temperature Rise	K	30			
Operating Temp. Range	°C	-10 to +50			
Dielectric Strength	V	500Vac for 1 min.		1000Vac for 1 min.	
Weight	g	35			

Magnet type: Anisotropic

Geared Models

PTM-24AG

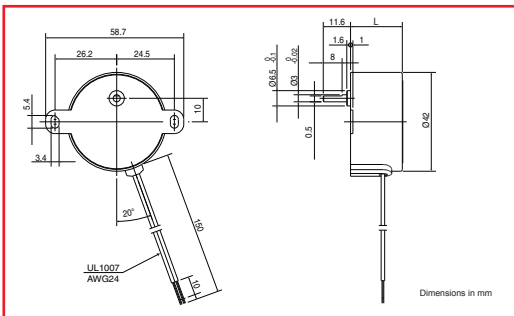

PTM-24BGII

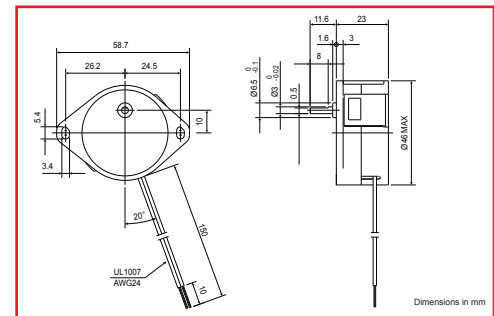

Geared Motor Torque Characteristics

Model	PTM-24AG			Motor Length (L)
Speed	Torque	Gear Ratio		
rpm	mN-m	50Hz	60Hz	
1/2	80	1/500	1/600	22
1/3	80	1/750	1/900	
1/5	80	1/1250	1/1500	
1/10	80	1/2500	1/3000	
1/30	80	1/7500	1/9000	
1/60	80	1/15000	1/18000	
1/2 rph	80	1/30000	1/36000	28
1/24 rph	80	1/360000	1/432000	

PTM-24AG has same electrical specs as PTM-24B

Model	PTM-24BGII		
Speed	Torque	Gear Ratio	
rpm	mN-m	50Hz	60Hz
10	10	1/25	1/30
4	25	2/125	1/75
2	50	1/125	1/150

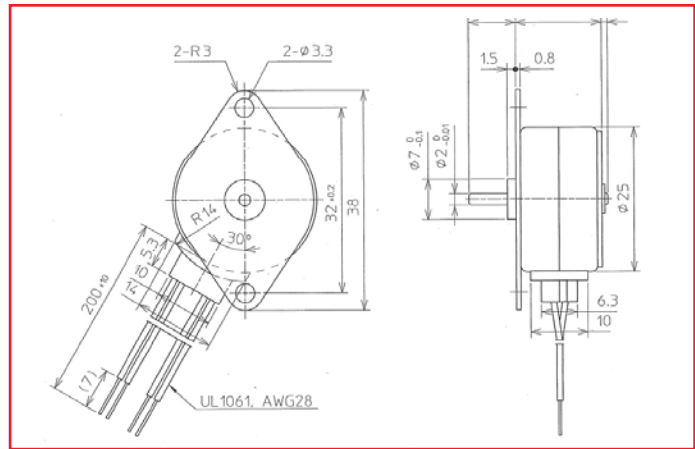

Specifications

Specifications	Units	PTMC-24P
Rated Voltage	V	24 ±10%
Frequency	Hz	50/60
Rated Current	mA	67/69
Revolutions	rpm	250/300
Rotating Direction		Dual Direction (CW/CCW)
Torque @ 60Hz	mN-m	5.3/5/5
Temperature Rise	K	55
Operating Temp. Range	°C	-10 to +50
Dielectric Strength	V	500Vac for 1 min.
Weight	g	35
Capacitor	µF	3.3

Magnet type: Anisotropic

Geared Models

PTMC-24PG

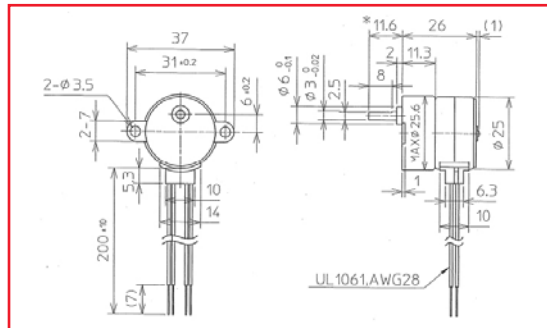

Geared Motor Torque Characteristics

Model	PTMC-24PG			
	Torque (mN-m)		Gear Ratio	
	50Hz	60Hz	50Hz	60Hz
rpm				
60	14	17	6/25	1/5
30	20*	20*	3/25	1/10
20	33	42	2/25	1/15
10	54	67	1/25	1/30
5	70*	70*	1/50	1/60
4	70*	70*	2/125	1/75
3	--	100*	--	1/100
2	100*	100*	1/125	1/150
1	100*	100*	1/250	1/300

*Values regulated by normal gear strength. Do not apply any load exceeding the normal gear strength.

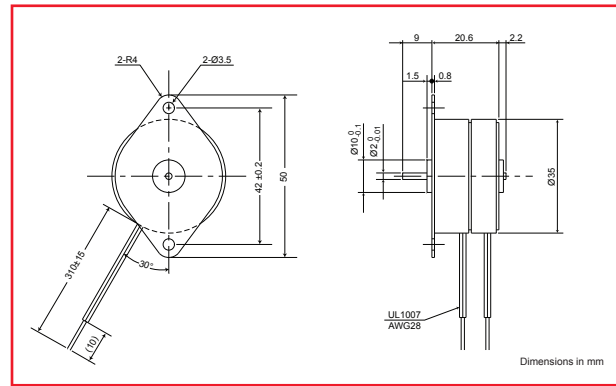

Specifications

Specifications	Units	PTM-24M	
Rated Voltage	V	24	100
Frequency	Hz	50/60	
Rated Current	mA	62/63	16/17
Revolutions	rpm	250/300	
Rotating Direction		Dual Direction (CW/CCW)	
Torque @ 60Hz	mN-m	12/12.5	
Temperature Rise	K	55	
Operating Temp. Range	°C	-10 to +50	
Dielectric Strength	V	500Vac for 1 min.	1000Vac for 1 min.
Weight	g	80	
Capacitor	µF	3.9	0.23

Magnet type: Anisotropic

Geared Models

PTM-24MG

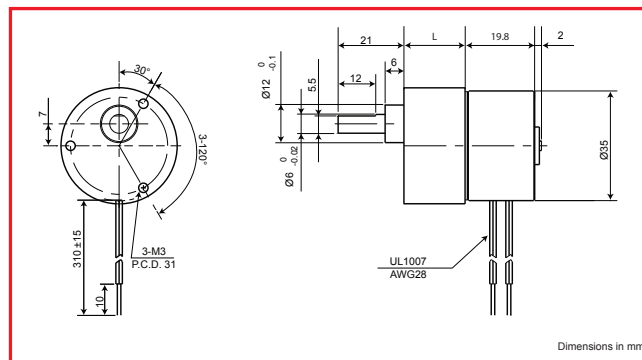

Geared Motor Torque Characteristics

Model	PTM-24MG				RPM	L
	Torque (mN-m)		Gear Ratio			
	50Hz	60Hz	50Hz	60Hz		
60	--	40	--	1/5	19.5mm	
30	--	80	--	1/10		
20	--	96	--	1/15		
10	150	190	1/25	1/30	21.7mm	
5	245	300*	1/50	1/60		
4	--	300*	--	1/75		
3	--	300*	--	1/100	23.8mm	
2	400	600*	1/125	1/150		
1	600*	600*	1/250	1/300		

*Values regulated by normal gear strength. Do not apply any load exceeding the normal gear strength.

Sold & Serviced By:
ELECTROMATE
 Toll-Free Phone: (977) SERV098
 Phone: (977) SERV099
 www.electromate.com
 sales@electromate.com

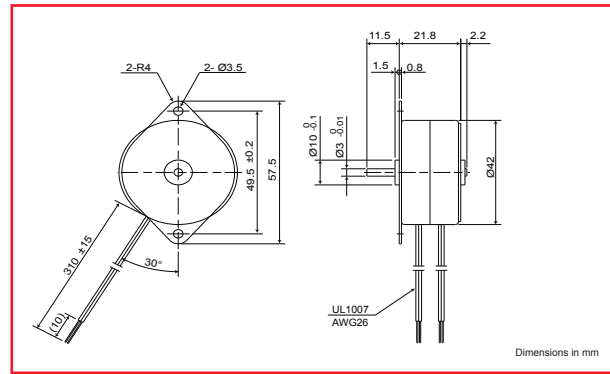

Specifications

Specifications	Units	PTM-24H	
Rated Voltage	V	24 ±10%	100 ±10%
Frequency	Hz	50/60	
Rated Current	mA	77/85	18/21
Revolutions	rpm	250/300	
Rotating Direction		Dual Direction (CW/CCW)	
Torque @ 60Hz	mN-m	22/21.5	
Temperature Rise	K	55	
Operating Temp. Range	°C	-10 to +50	
Dielectric Strength	V	500Vac for 1 min.	1000Vac for 1 min.
Weight	g	160	
Capacitor	µF	5.6	0.27

Magnet type: Anisotropic

Geared Models

PTM-24HG

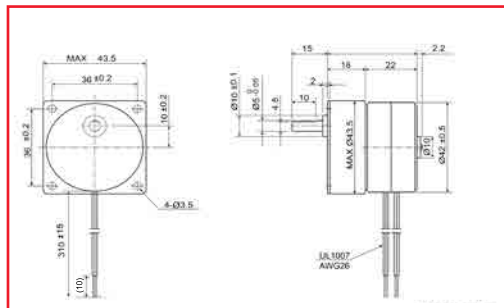

Geared Motor Torque Characteristics

Model	PTMC-24HG				
	Speed	Torque (mN-m)		Gear Ratio	
		50Hz	60Hz	50Hz	60Hz
60	58	68	6/25	1/5	
30	115	135	3/25	1/10	
20	140	165	2/25	1/15	
10	250*	260	1/25	1/30	
5	300*	300*	1/50	1/60	
4	300*	300*	2/125	1/75	
3	--	400*	--	1/100	
2	400*	400*	1/125	1/150	
1	400*	400*	1/250	1/300	

*Values regulated by normal gear strength. Do not apply any load exceeding the normal gear strength.

Sold & Serviced By: **ELECTROMATE**

Toll Free Phone (877) SERV098
Toll Free Fax (877) SERV099
www.electromate.com
sales@electromate.com

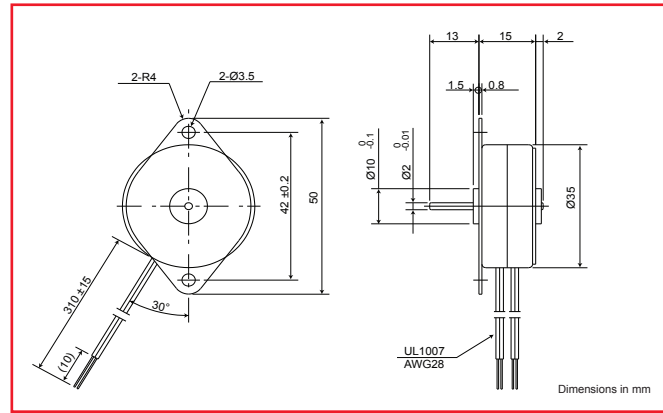

Specifications

Specifications	Units	PTM-24T
Rated Voltage	V	24 ±10%
Frequency	Hz	50/60
Rated Current	mA	68/70
Revolutions	rpm	250/300
Rotating Direction		Dual Direction (CW/CCW)
Torque @ 60Hz	mN-m	9/9.5
Temperature Rise	K	55
Operating Temp. Range	°C	-10 to +50
Dielectric Strength	V	500Vac for 1 min
Weight	g	77
Capacitor	µF	3.3

Magnet type: Anisotropic

Geared Models

PTM-24TG

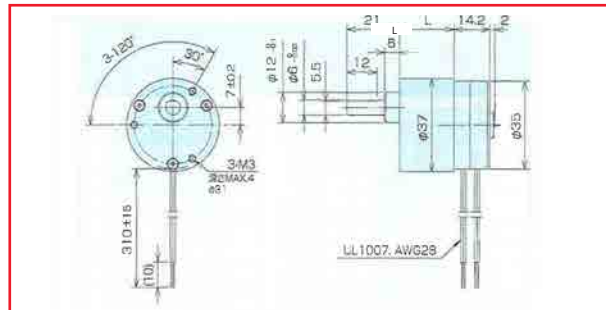

Geared Motor Torque Characteristics

Model	PTM-24TG				RPM	L
	Torque (mN-m)		Gear Ratio			
	50Hz	60Hz	50Hz	60Hz		
60	--	30	--	1/5	19.5mm	
30	--	60	--	1/10		
20	--	72	--	1/15		
10	115	145	1/25	1/30	21.7mm	
5	180	230	1/50	1/60		
4	--	290	--	1/75		
3	--	300*	--	1/100	23.8mm	
2	365	465	1/125	1/150		
1	--	600*	--	1/300		

*Values regulated by normal gear strength. Do not apply any load exceeding the normal gear strength.

Sold & Serviced By:
ELECTROMATE

Toll-Free Phone: (977) SERV098
 COM-Fax: (977) SERV099
 www.electromate.com
 sales@electromate.com

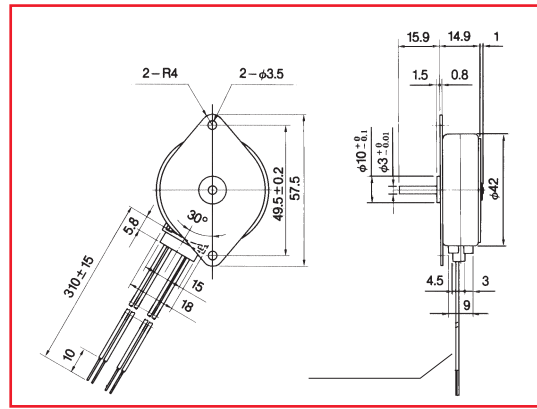

Specifications

Specification	Unit	PTMC-24S2
Rated Voltage (AC)	V	24 ±10%
Frequency	Hz	50/60
Rated Current	mA	110/115
Revolutions	rpm	250/300
Rotating Direction		Dual Direction (CW/CCW)
Torque (@60Hz)	mN-m	20.5/19.5
Temperature Rise	K	70
Operating Temp. Range	°C	-10 to +50
Dielectric Strength	V	500Vac for 1 min.
Weight	g	105
Capacitor	μF	5.6

Magnet type: Anisotropic

Geared Models

PTMC-24S2G

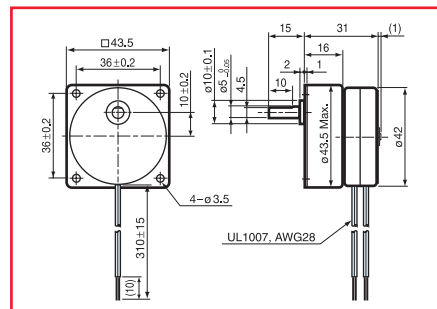

Geared Motor Torque Characteristics

Model	PTMC-24S2G (gearhead)			
	Torque (mN·m)		Gear Ratio	
	50Hz	60Hz	50Hz	60Hz
60	49	55	6/25	1/5
30	98	110	3/25	1/10
20	115	135	2/25	1/15
10	235	220	1/25	1/30
5	300*	300*	1/50	1/60
4	300*	300*	2/125	1/75
3	--	400*	--	1/100
2	400*	400*	1/125	1/150
1	400*	400*	1/250	1/300

*Values regulated by normal gear strength. Do not apply any load exceeding the normal gear strength.



Toll Free Phone (877) SERV098
Toll Free Fax (877) SERV099
www.electromate.com
sales@electromate.com

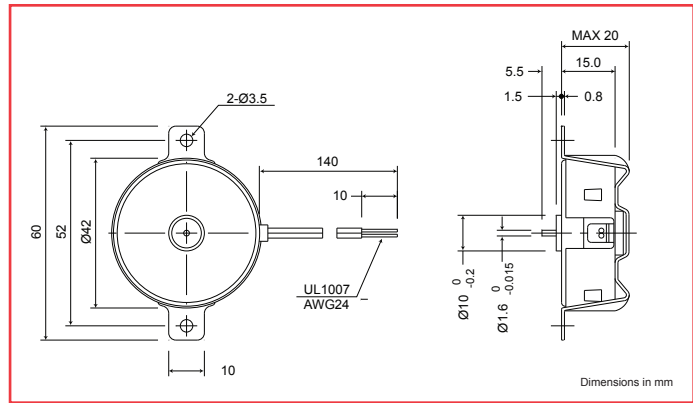

Specifications

Specifications	Units	PTM-12K			
Rated Voltage	V	12	24	100	200
Frequency	Hz	50/60			
Rated Current	mA	160/150	110/100	17/16	7.5/7
Revolutions	rpm	500/600			
Rotating Direction		Single Direction (CW/CCW)			
Torque @ 60Hz	mN-m	1.0/0.9			
Temperature Rise	K	35			
Operating Temp. Range	°C	-10 to +50			
Dielectric Strength	V	500Vac for 1 min.		1000Vac for 1 min.	
Weight	g	90			

Magnet type: Anisotropic

Geared Models

PTM-12KG

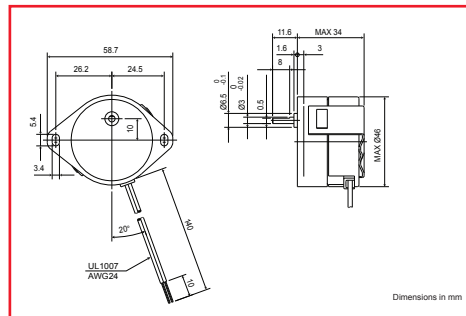

Geared Motor Torque Characteristics

Model	PTM-12KG		
	Speed	Torque	Gear Ratio
rpm	mN-m	50Hz	60Hz
10	50	1/50	1/60
2	150	1/250	1/300
1	200	1/500	1/600

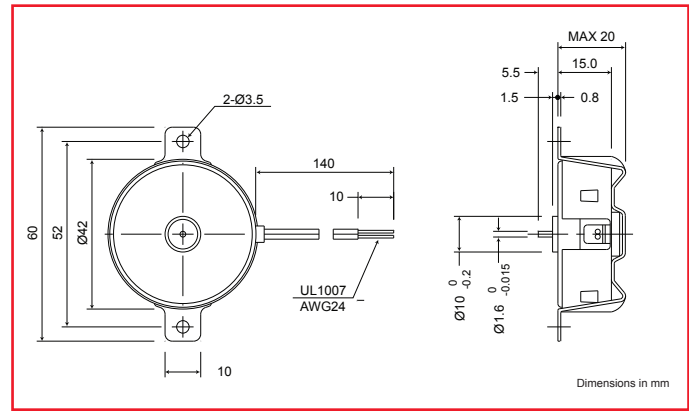

Specifications

Specifications	Units	PTM-12E			
		12	24	100	200
Rated Voltage	V	12	24	100	200
Frequency	Hz	50/60			
Rated Current	mA	160/140	88/79	20/19	10/9
Revolutions	rpm	500/600			
Rotating Direction		Single Direction (CW/CCW)			
Torque @ 60Hz	mN-m	1.7			
Temperature Rise	K	45			
Operating Temp. Range	°C	-10 to +50			
Dielectric Strength	V	500Vac for 1 min.		1000Vac for 1 min.	1500Vac for 1 min.
Weight	g	95			

Magnet type: Anisotropic

Geared Models

PTM-12EG

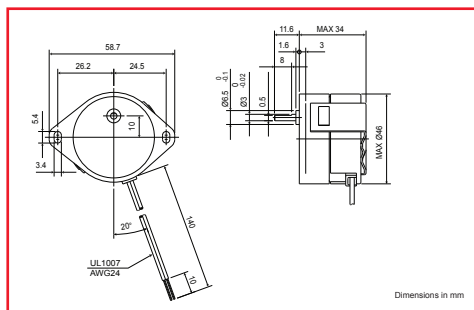

Geared Motor Torque Characteristics

Model	PTM-12EG		
	Speed rpm	Torque @ 60Hz mN-m	Gear Ratio
50Hz			60Hz
10	60	1/50	1/60
2	200	1/250	1/300
1	200	1/500	1/600

Motor Customization and Custom Motor Manufacturing

Nippon Pulse understands that each motor application may require modifications to off-the-shelf products.

In addition to fully custom motor designs, below are some of the modifications we can offer on our standard tin-can, synchronous and linear stepper motors. We also offer customizations and fully custom Linear Shaft Motors to meet your application requirements. Any of our standard series motors can be customized to meet the unique needs of your application.

Contact Nippon Pulse for more information on product customization or fully custom motor designs.

Shaft Modifications



Flat(s)



Knurling



V-Groove



Thru-Hole

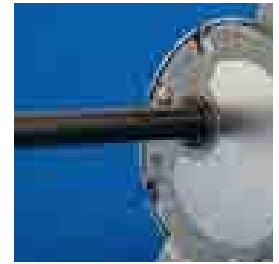

Threading



Pinion Gear
(press fit, set screw or
spring pin)



Extended Shaft



Double Shaft



Slot



Worm Gear

Additional Modifications



Longer or Shorter
Lead Length



Connectors



Plastic Tubing
(regular or heat shrink)



Twisted Leads



Ball Bearings



Flange



Lead Wire Exit Location

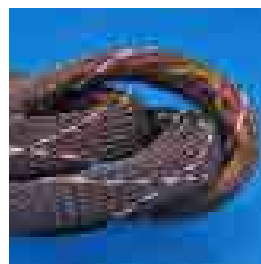

Mesh Tubing



Stopper

AD Series Driver Boards



AD1111

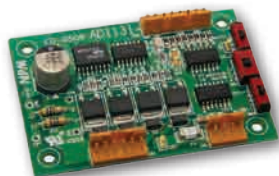

AD1131



AD1231



AD1431

AD Series	AD1111	AD1131	AD1231	AD1431
Electrical Specifications				
Input Power Supply	5 to 30 ±5% Vdc	5 to 30 ±5% Vdc	12 to 24 ±10% Vdc	12 to 24 ±10% Vdc
Drive Method	Unipolar Constant Voltage	Unipolar Constant Voltage	Unipolar Constant Current	Bipolar Constant Current
Excitation Mode	Full, Half	Full, Half	Full, Half, 1/4, 1/8, 1/16	Full, Half, 1/4, 1/16
Output Current	350mA	1.1A	2.0A	1.2A
Control Signals				
Input Interface	Photocoupler	Photocoupler	Photocoupler	Photocoupler
Input Signal	CW/CCW, PULSE/DIR	CW/CCW, PULSE/DIR	CW/CCW, PULSE/DIR	CW/CCW, PULSE/DIR
Environmental Conditions				
Operating Temperature	0 to +50°C	0 to +50°C	0 to +50°C	0 to +50°C
Storage Temperature	-10 to +60°C	-10 to +60°C	-10 to +60°C	-10 to +60°C
Other				
Dimensions	70mm x 49mm x 17mm	70mm x 49mm x 17mm	60mm x 50mm x 30mm	60mm x 50mm x 30mm
Weight	20g	20g	43g	35g
RoHS Compliant	Yes	Yes	Yes	Yes

Controllers

PPCI Series



The PPCI series (PPCI7443) is an advanced PCI-bus format 4-axis motion control board that controls stepper motors or/and servomotors. The PPCI7443 incorporates a PCL6045 series chip as part of its compact design, and it comes with user-friendly software that incorporates MS-DOS, VB/VC++ programming library; Windows 2000, XP, Vista, 7, 8 (32-bit and 64-bit); and a test monitor. The software allows for easy set-up and supports up to 12 PPCI7443 cards for operation of up to 48 axes.

NPMC Series



The NPMC series is an advanced PC/104-bus format multi-axes motion-control board that controls stepper motors and/or servomotors. The PCL6045BL motion-control chip is used as key component for 4-axes (NPMC6045A-4104) controller boards, and is available for Windows 2000, XP, Vista, 7 and 8 (32-bit and 64-bit).

Motion Checker 5



Nippon Pulse Motion Checkers are palm-sized controller kits that come equipped with a power supply and stepper motor. The Motion Checker has a built-in integrated driver circuit for 2-phase unipolar or bipolar stepper motors. A pulse/direction output signal is also available, enabling its use as a standalone controller to connect to any driver board.

The Motion Checker series can be used for quick stepper motor evaluation, stepper motor life testing, and educational training.

FMC32



Nippon Pulse's FMC32 is a single-axis controller with integrated bipolar chopper drive for stepper motors. This board allows users to register up to 32 operation patterns and 256 execution sequences, and stores them internally on non-volatile memory for standalone operation. This board features Nippon Pulse's PCD2112 controller chip, which allows users to save programs via a USB-to-4-wire serial conversion unit.

Nippon Pulse has made it simple for you to test your application and get it up and running. Simply choose the proper motor, controller and driver for your application needs to get started. Follow the simple steps below, or contact one of our applications engineers for assistance.

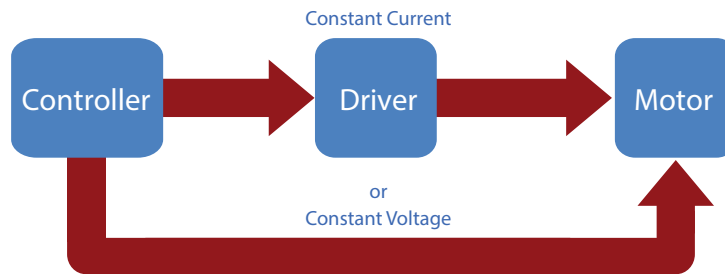

Step 1: Pick your controller.

- **MCH-5 Motion Checker:** Handheld single axis (no computer required). Allows up to six different motion profiles, which can run indefinitely. Available with a built-in Constant Voltage (12V) driver for Unipolar (250mA) or Bipolar (400mA) steppers with full or half step. Pulse and direction output to connect external Constant Current driver.
- **FMC32:** Small, single-axis controller (SPI or USB interface). Allows up to 32 different motion profiles, which can run indefinitely. Built-in Constant Current driver for Bipolar (500mA) steppers with full or half step. Pulse and direction output to connect external stepper motor driver.
- **PPCI or NPMC:** Four-axis controllers (PCI or PC/104 bus). Fully configureable with advanced profiles such as circular and linear interpolation. Pulse and direction output to connect external stepper motor driver.

Step 2: Select the proper driver for your application and motor.

Use the chart on page 42 to make your selection. If using an MCH-5 or FMC32 controller, you only need an external driver if the built-in driver on these controllers doesn't meet your needs.

Step 3: Pick your motor.

Which series, size and type of motor do you require? You can use this evaluation kit to test any of our tin-can, LINEARSTEP, linear hybrid or hybrid stepper motors. Choose the standard motor and size that is the closest fit for your application; if you are interested in customizing a motor or receiving a fully custom design, contact one of our applications engineers to learn more about our capabilities and pricing.

Step 4: Contact Nippon Pulse to receive your prototype motor and evaluation testing kit.

Our kit allows you to test the motor, controller and driver in your application to ensure a perfect fit before placing a larger order.

info@nipponpulse.com | 1-540-633-1677

Contact one of our applications engineers to discuss your selections or receive assistance in making a selection.

Custom Specification Form

Let us help you determine which Nippon Pulse stepper motor will best fit your application. Complete as much information as possible and send the form to one of our sales engineers (f: 1-540-633-1674; e: info@nipponpulse.com). One of our sales engineers will be in contact with you shortly to discuss your needs.

Name: _____
 Company: _____ Title: _____
 Telephone: _____ Fax: _____
 Address: _____
 City: _____ State: _____ Zip: _____
 E-mail Address: _____

Product(s) Interested in (check all that apply):
 PF Series (Tin-Can Stepper) Linear Hybrid Stepper Linear Stepper

Specific Product (Model Number): _____

Application: _____

Quantity: _____ Target Price: _____

Driving Method: Bipolar Unipolar

Constant Current at: _____ mA/phase Constant _____ V

Excitation Mode:

2 Phase 1-2 Phase 1-4 Phase 1-8 Phase
 1 Phase Other

Winding Resistance: _____ Ω Stepping Angle: _____ at 2 Phase

Max Speed: _____ pps Scope of Operation: _____ pps - _____ pps

Pull-in Torque: _____ mN·m at _____ pps 2-2 Phase or 1-2 Phase

Pull-out Torque: _____ mN·m at _____ pps 2-2 Phase or 1-2 Phase

Outline Dimensions:

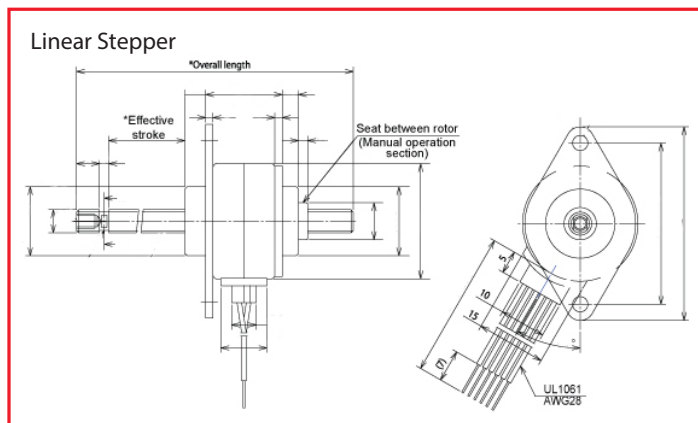
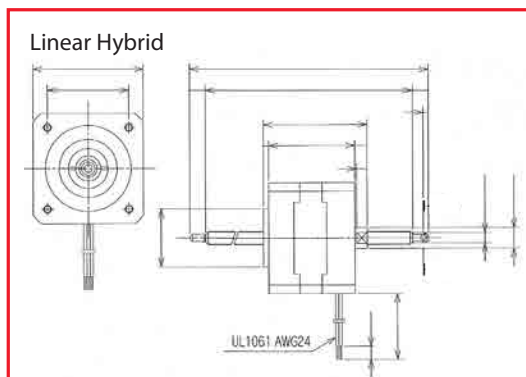
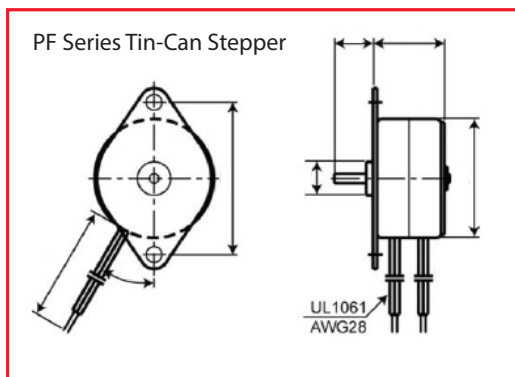

Pinion Gear			
Module		# of teeth	
Pressure Angle		Outer Diameter	
Length		Shift	
Quality class		Material	
Other:			

Lead Wires								
Nos.	1	2	3	4	5	6	7	8
Lead Color								
Phase								

Sold & Serviced By:
ELECTROMATE
 Toll Free Phone (877) SERV098
 Toll Free Fax (877) SERV099
www.electromate.com
sales@electromate.com

In addition to our stepper motors, controllers and drivers, Nippon Pulse offers other motion control products to meet all your application needs.

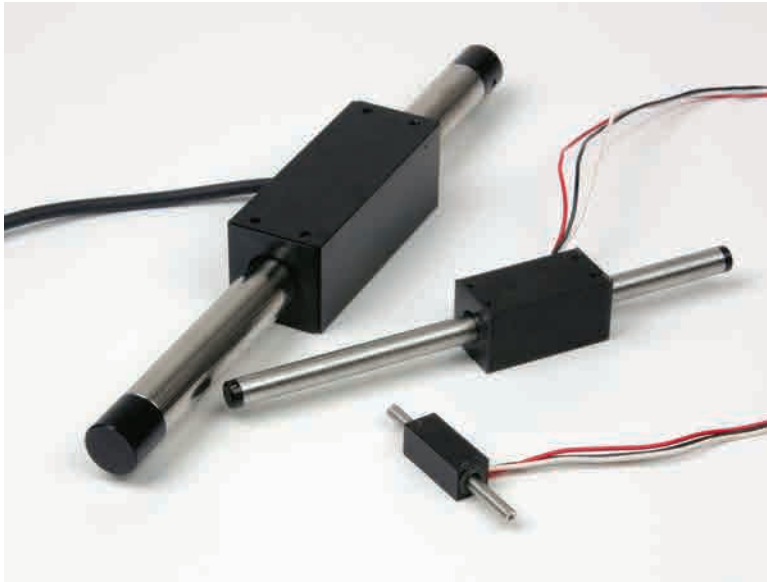

Linear Shaft Motors

Nippon Pulse's Linear Shaft Motor is a simple, high-efficiency, high-precision direct drive linear servo motor with a tubular design. The motor consists of a magnetic shaft and coil assembly (forcer), and is driven and controlled by the flow of current.

The Linear Shaft Motor can replace ball-screws, piezo, U-shaped motors and other linear motion systems, and requires no maintenance over its lifetime.

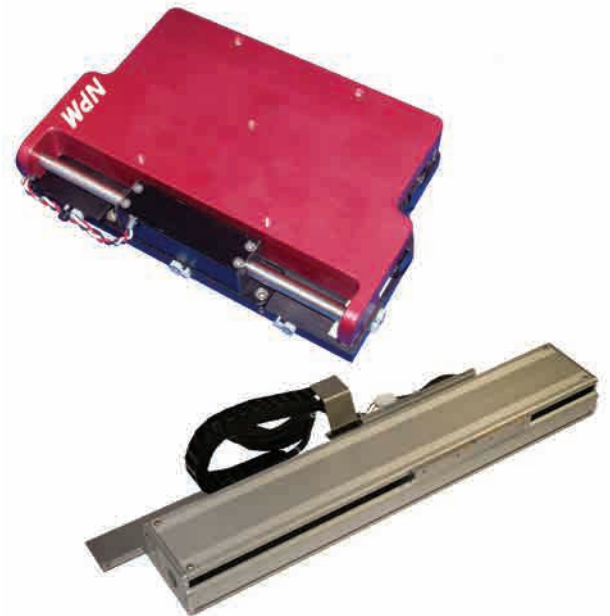

SCR and SLP Linear Stages

Nippon Pulse offers two types of linear stages that incorporate our patented Linear Shaft Motor servo. The SCR Nanopositioning linear translation stages offer the accuracy of piezo-driven stages with the speed and performance of servo stages. The SCR stage produces extremely accurate results with no loss in stability.

The SLP Acculine translation stages offer high-precision stages for industrial applications, simplifying the transition from conventional ball-screw systems. With a smaller deadzone than any other stage system available, none can match the SLP's force-to-volume ratio, making it an outstanding solution for those with space limitations.



Controller Chips

Nippon Pulse's programmable pulse generators are motion control chips that are designed to control stepper motors and servomotors. These chips reduce the computational burden on the system's microprocessor while allowing for a wide array of advanced motion control features.

Nippon Pulse offers a variety of chip series that have a variety of strengths. Our available series include ultra-high performance chips with interpolation functions, low-cost chips for simple motion control, and miniature standalone chips.

For more information about these or any of our products, visit nipponpulse.com or contact an applications engineer.

Your Partner In Motion Control

 **ELECTROMATE**

Toll-Free Phone: (877) SERV098

Phone: (415) SERV099

www.elect-omate.com

sales@electomate.com

NIPPONPULSE.COM

NPM Worldwide

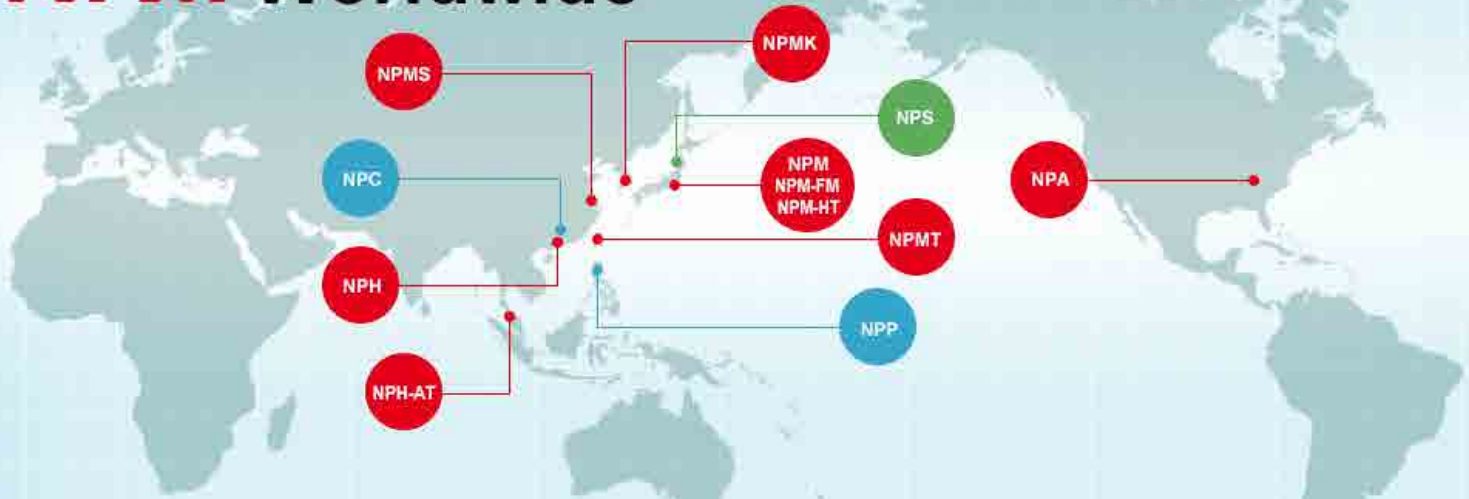

Nippon Pulse has subsidiary offices, sales offices, affiliates and production factories in 11 locations. Nippon Pulse America also has sales representatives and distributors across the United States and Europe.



NPM
Nippon Pulse Motor Co., Ltd.
Head Office
Tokyo, Japan



NPA
Nippon Pulse America, Inc.
Sales Office
Radford, Virginia



NPH
Nippon Pulse Hong Kong, Ltd.
Managing Office
Hong Kong, China



NPMK
Nippon Pulse Korea Co., Ltd.
Sales Office
South Korea



NPMS
Nippon Pulse Shanghai Co., Ltd.
Sales Office
Shanghai, China



NPM-HT
NPM High Technologies Co., Ltd.
Sales Office
Tokyo, Japan



NPMT
Nippon Pulse Motor Trading Taiwan Co. Ltd.
Sales Office
Taiwan



NPH-AT
Nippon Pulse Asia Trading Ltd.
Sales Office
Malaysia



NPS
NPS Co., Ltd.
Affiliate
Akita, Japan



NPC
Pulse Electronics Co. Ltd.
Production
Guangdong Province, China



NPP
Nippon Pulse Tec Philippines Inc.
Production
Philippines

About Nippon Pulse

Nippon Pulse provides a wide array of motion-control solutions to meet your needs, including industry-leading stepper motors, the innovative Linear Shaft Motor, controllers, drivers and networks. With several customization options, we provide products that can be utilized in an extensive number of applications.

Your Partner in Motion Control

At Nippon Pulse, we approach customer applications from an overall project standpoint. This enables us to provide the best electro-mechatronic solutions to help you design and build your motion-control systems. Our system engineering services include complete design, engineering and manufacturing. We have worked on applications such as pick-and-place machines, large scale sorting and distributing systems, biomedical handling equipment, healthcare products and more. Our sales engineers have extensive product knowledge and can help you determine the best solution for your motion-control application.

From standard industrial sectors to the high-level electronics, Nippon Pulse optimizes development and manufacturing, and provides many high-performance product groups. In order to provide the most efficient products and facilities, we are always conscious of a smooth flow from planning to design and manufacturing. This efficient flow makes it possible to create a wide variety of products to meet our customers' needs.

It is essential that we provide products that exceed customer expectations, so they are able to use them with complete confidence. Maintaining excellent quality while ensuring a stable supply chain for each of our products is achieved by thorough quality control methods. These methods guarantee reliability above industry standards.

Whether we provide an entire system or just one motor, ensuring those products exceed expectations is part of our methodology. We guarantee this through in-depth communication with the customer from the design phase through delivery and beyond installation.

We strive to ensure all aspects of our process allow us to meet and exceed customer expectations through communication, support and reliable products.

In-House Model Shop

The Nippon Pulse model shop provides quick turnaround on prototype requests for our tin-can stepper motors. Most requests can be shipped within 24 hours, allowing you to test the product in your application before committing to a purchase order. Nippon Pulse sales engineers work closely with you to understand your project so we are able to suggest the best solution possible and get a high-quality prototype to you quickly. Nippon Pulse offers the flexibility to ship just one piece to make sure our product is the correct fit for your project. In addition to the tin-can type stepper motors, we have various linear step motors, hybrid motors, controllers, and drivers in stock for quick prototyping.

INDUSTRIES WE SERVE

Automation
Bio-Medical & Medical
Equipment Manufacturing
Instrumentation
Machine Tooling
OEM
Packaging
Pharmaceutical
Photonics
Semiconductor

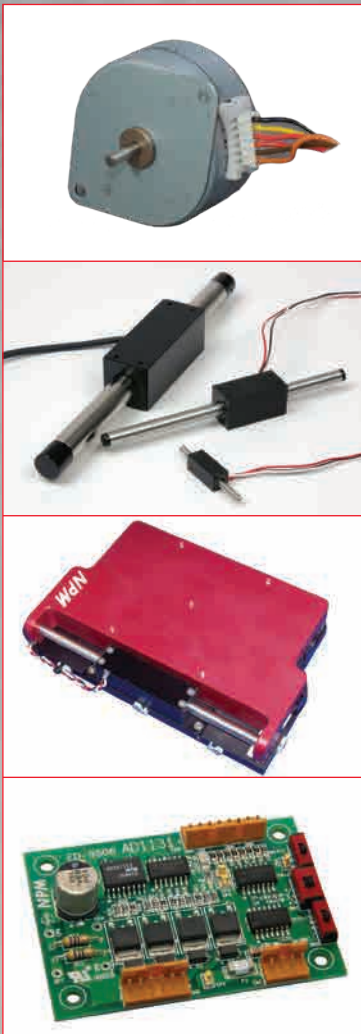

Sold & Serviced By:
 ELECTROMATE

Toll Free Phone (877) SERV098
Toll Free Fax (877) SERV099
www.electromate.com
sales@electromate.com

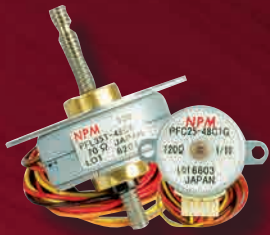

The Nippon Pulse Advantage



For more than 60 years, Nippon Pulse has built state-of-of-the-art products based on a solid foundation of advancing technology and thorough product research.

Nippon Pulse faithfully provides these high-quality products to a wide range of industries in North and South America and Europe. We have established ourselves as a leader in stepper motor, driver and controller technology while introducing innovative products, such as the Linear Shaft Motor. At Nippon Pulse, we believe that by bringing products to market that meet the customers' requirements and exceed expectations, we contribute to the progression of technology and its positive impact on our society.

We have representatives throughout North and South America and Europe to assist customers directly. Limited quantities of stock on standard motors and electronics are available to allow faster response to customer needs. In addition, Nippon Pulse has a model shop in its North American headquarters for quick turnaround on custom prototypes and special orders. Our mission is to faithfully create the new products sought by our customers and to contribute to the development of society from a global viewpoint.

When you choose a Nippon Pulse motor, driver, controller, network or stage, you're doing more than just buying a quality product: you're benefitting from what we call the Nippon Pulse Advantage. This includes superior prototyping, complete system engineering, proper compliance and certification according to international guidelines, exceptional tailoring to your needs, and unmatched support.

A wholly owned subsidiary of Nippon Pulse Motor Co., Ltd., Nippon Pulse America is headquartered in Radford, Va.

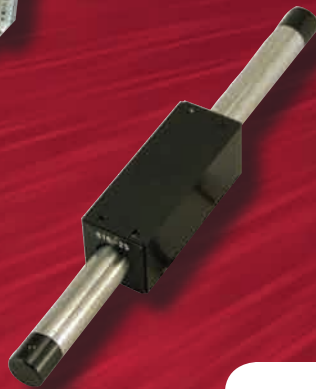

NPM

4 Corporate Drive
Radford, VA 24141 USA
phone: 1-540-633-1677 ... fax: 1-540-633-1674
nipponpulse.com ... info@nipponpulse.com

Nippon Pulse Representative Information



FS 645238

EMS 645237

Sold & Serviced By:
Stepper Motor Catalog 2016
Copyright 2016 | Nippon Pulse | All Rights Reserved
ELECTROMATE
Toll Free Phone (877) SERV088
Toll Free Fax (877) SERV088
www.electromate.com
sales@electromate.com