

Visit nipponpulse.com to download 3D CAD drawings and 2D prints of this motor.

	S080D		S080T		S080Q		
Electrical Specs	S080D	S080D 1S	S080T	S080T 1S	S080Q	S080Q 2S	S080Q 1S
Continuous Force ¹	1.8N (0.4lbs)		2.7N (0.61lbs)		3.5N (0.79lbs)		
Continuous Current ¹	0.84Arms	1.7Arms	0.84Arms	2.5Arms	0.84Arms	1.7Arms	3.4Arms
Acceleration Force ²	7.2N (1.6lbs)		11N (2.4lbs)		14N (3.1lbs)		
Acceleration Current ²	3.4Arms	6.7Arms	3.4Arms	10Arms	3.4Arms	6.7Arms	13Arms
Force Constant (K _f)	2.1N/Arms (0.48lbs/amp)	1.1N/Arms (0.25lbs/amp)	3.2N/Arms (0.72lbs/amp)	1.1N/Arms (0.25lbs/amp)	4.2N/Arms (0.94lbs/amp)	2.1N/Arms (0.47lbs/amp)	1.0N/Arms (0.22lbs/amp)
Back EMF (K _e)	0.71V/m/s (0.02V/in/s)	0.36V/m/s (0.01V/in/s)	1.1V/m/s (0.03V/in/s)	0.36V/m/s (0.01V/in/s)	1.4V/m/s (0.04V/in/s)	0.70V/m/s (0.02V/in/s)	0.35V/m/s (0.01V/in/s)
Resistance 25°C, ³	4.7Ω	1.2Ω	6.8Ω	0.76Ω	9.0Ω	2.3Ω	0.56Ω
Inductance ³	0.7mH	0.18mH	1.0mH	0.11mH	1.3mH	0.33mH	0.081mH
Electric Time Constant	0.149ms		0.147ms		0.144ms		
Max. Rated Voltage (AC)	240V						
Fundamental Motor Constant (K _m)	0.98N√W		1.23N√W		1.39N√W		
Magnetic Pitch (North-North)	30mm (1.18in)						

Is this the proper Linear Shaft Motor for your application? Use our [SMART sizing program](#) to assist in your decision.

This motor can be customized to fit your application demands; contact your application engineer for more information.

¹ Based on a temp rise of coil surface of 110°K over 25°C ambient temperature stalled forcer, and no external cooling or heat sinking.

² Can be maintained for a maximum of 40 seconds. Higher forces and current possible for short periods of time, consult Nippon Pulse for more information.

³ All winding parameters listed are measured line-to-line (phase-to-phase).

Thermal Specs	S080D	S080T	S080Q
Max Phase Temperature ⁴	135°C (275°F)		
Thermal Resistance (Coil) (K _q)	33.2°C/W (92°F/W)	22.9°C/W (73°F/W)	17.3°C/W (63°F/W)

⁴ The standard temperature difference between the coil and the forcer surface is 10°C.

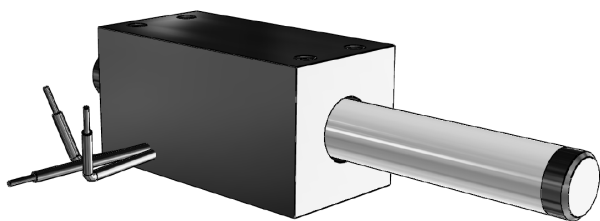

Bus Voltage

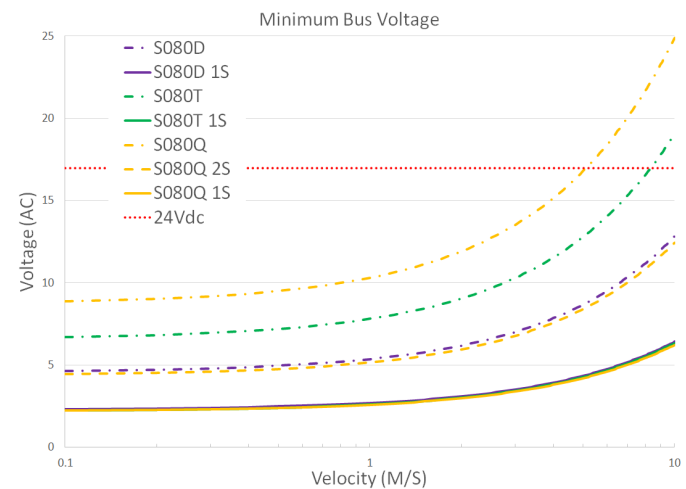

Part Numbering System

S	Shaft Size 080	Forcer Size (A) <u>X</u>	Parallel Option <u>XX</u>	Usable Stroke (S) <u>XXXXst</u>	Options <u>XX</u>	Options <u>XX</u>
		D: Double (2) windings T: Triple (3) windings Q: Quadruple (4) windings	Blank: Single Motor PL: Parallel Motors	25-300mm	Blank: Standard WP: Water Resistant HA: Digital Hall Effect CE: CE type motor FG: Frame Ground	Blank: Standard FO: Forcer Only SO: Shaft Only

Forcer Specs	S080D	S080T	S080Q
Forcer Length (A)	40mm (1.57in)	55mm (2.17in)	70mm (2.76in)
Forcer Width	20mm (0.79in)		
Forcer Screw Pitch (P)	34mm (1.34in)	49mm (1.93in)	64mm (2.52in)
Forcer Weight	0.05kg (0.11lbs)	0.06kg (0.13lbs)	0.08kg (0.18lbs)
Gap	0.50mm (0.02lbs)		

Tolerances are as follows:

Dimension (mm)	Tolerance (mm)
0 - 6	±0.1
7 - 30	±0.2
31 - 120	±0.3
121 - 315	±0.5
316 - 1000	±0.8
1001 - 2000	±1.2
2000 -	±1.5

L = See Shaft Length
L1 = Usable Stroke + A
L2 = See Support Length
A = See Forcer Length
P = See Forcer Screw Pitch

Unless otherwise specified, dimensions are in mm

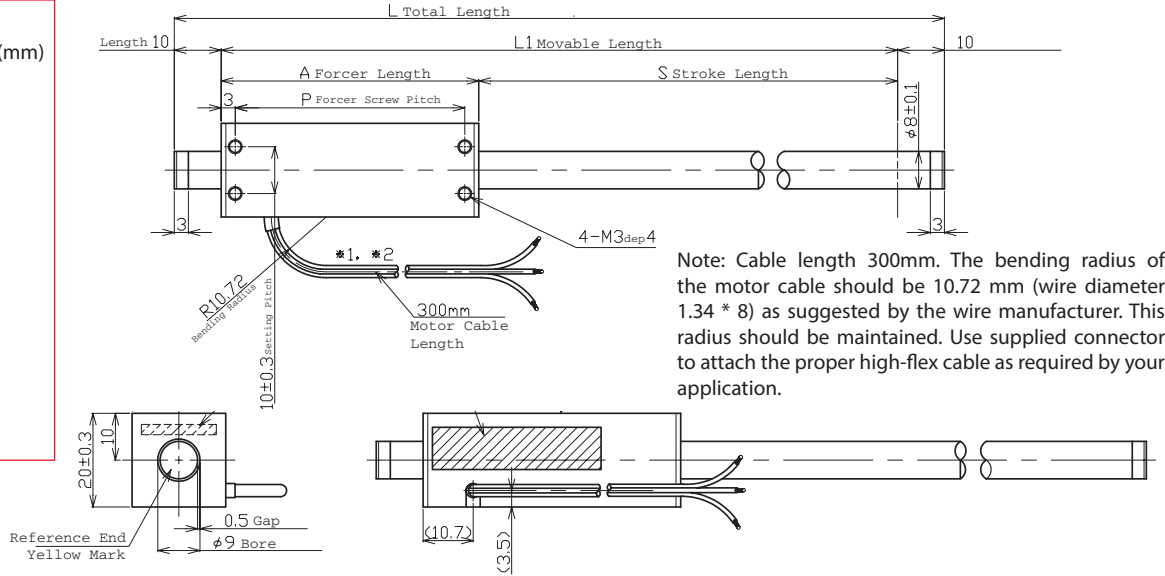

Hall Effect Specs

Forcer Length (A)
Forcer Screw Pitch (P)
Forcer Screw Pitch 10
0.39
1.10
28
0.79
20

Sensor Cable Specs

Wire Type	UL 758
Wire AWG	28
VCC	White/Red
GND	White/Black
Sensor 1	Orange/Red
Sensor 2	Orange/Black
Sensor 3	Gray/Red
No Connection	Gray/Black

The bending radius of the sensor cable should be R10.72 mm (wire diameter 1.38 * 8) as suggested by the wire manufacturer. This radius should be maintained.

FG Type Motor Cable

Wire Type	UL 1330
Wire AWG	20
Frame Ground	Green/Yellow

Shaft Length (L)

Stroke	S080D	S080T	S080Q
25	85mm (3.3in)	100mm (3.9in)	115mm (4.5in)
50	110mm (4.3in)	125mm (4.9in)	140mm (5.5in)
100	160mm (6.3in)	175mm (6.9in)	190mm (7.5in)
150	210mm (8.3in)	225mm (8.9in)	240mm (9.4in)
200	260mm (10.2in)	275mm (10.8in)	290mm (11.4in)

Shaft Diameter (D) - 8mm ±0.1

Total Length (L)=Stroke (S)+Forcer Length (A)+(Support Length (L2)x2)

Additional stroke lengths are available (up to 230mm for S080D and up to 215mm for S080T). Contact Nippon Pulse for more information.

Shaft Mass

Stroke	S080D	S080T	S080Q
25	0.02kg (0.05lb)	0.03kg (0.06lb)	0.03kg (0.07lb)
50	0.03kg (0.07lb)	0.04kg (0.08lb)	0.04kg (0.09lb)
100	0.05kg (0.11lb)	0.05kg (0.12lb)	0.06kg (0.13lb)
150	0.07kg (0.15lb)	0.07kg (0.16lb)	0.08kg (0.17lb)
200	0.08kg (0.19lb)	0.09kg (0.2lb)	0.1kg (0.21lb)

Forcer Spacing Distance

Spec	S080T	S080Q
Forcer Spacing Distance	5mm	
Pole (N/S) Distance	15mm	
Forcer Length	55mm	70mm
Flip Forcers	No	Yes

Tandem S080D forcers are possible, but are equivalent to one (1) S080Q forcer and thus are not listed above.

Tandem Forcer



Forcer Spacing Distance

Support and Bending

Stroke	Support Length (L2)	Max. Bending
All	10mm	0.05mm

Connector (Motor Cable)

Receptacle Housing	XMR-03V
Plug Housing	XMP-03V
Retainer	XMS-03V
Pin Contact	SXM-001T-P0.6
Socket Contact	SXA-001T-P0.6

To be installed by the user.

Standard Lead Wire

Wire Type	UL 1430
Wire AWG	28
U Phase	Red
V Phase	White
W Phase	Black

300mm lead wire bare leads. The bending radius of the motor cable should be 10.72 mm as suggested by the wire manufacturer.

CE Type Lead Wire Option

Ground Wire	CE
Wire Type	UL 1330
Wire AWG	24
U Phase	Red
V Phase	White
W Phase	Black

300mm lead wire bare leads. The bending radius of the motor cable should be 16.96mm as suggested by the wire manufacturer. FG type with insulating sheet between coils and case. Meets all requirements of EN60034-1 (1998).

Note: Metric units guaranteed. Imperial (United States customary) units are calculated.

For assistance in selecting the best motor for your application, contact Nippon Pulse to speak with an applications engineer. 1-540-633-1677

www.nipponpulse.com

Serviced By:

 Toll Free Phone (877) SERV098
 Toll Free Fax (877) SERV099
www.electromate.com
sales@electromate.com