

The DS-40 is a member of the DS series of Electric Encoders™ a product line based on Netzer Precision Position Sensor proprietary technology. EE products are characterized by features that enable unparalleled performance:

- Low profile (10 mm)
- Hollow, floating shaft
- No bearings or other contact elements
- High resolution and unparalleled precision
- High tolerance to temperature extremes, shock, EMI, RFI and magnetic fields
- Very low weight
- Holistic signal generation
- Digital interfaces for absolute position

### General

Angular resolution	17-19 bit
Maximum tested static error	±0.020°
Extended accuracy static error	±0.010°
Maximum operational speed	4,000 rpm
Measurement	Single turn absolute position
Rotation direction	Adjustable CW/CCW
Build In Test BIT	Optional

\* Default same direction from bottom side of the encoder

### Mechanical

Allowable mounting eccentricity	±0.1 mm
Allowable axial mounting tolerance	±0.1 mm
Rotor inertia	70.93 gr · mm <sup>2</sup>
Total weight	20 gr (with 250mm cable)
Outer Ø / Inner Ø / Height	40 / 10 / 10 mm
Material	Ultem™ polymer / TRVX-50

The Electric Encoder™ is unique in being holistic, i.e., its output reading is the averaged outcome of the whole area of the rotor. This feature makes the Electric Encoder™ forgiving to mounting tolerances, mechanical wander etc.

The absence of components such as ball bearings, flexible couplers, glass disc, light sources and detectors, along with very low power consumption makes the Electric Encoder™ virtually failure free.

The internally shielded, DC operated Electric Encoder™ includes an electric field generator, a field receiver, a sinusoidal shaped dielectric rotor, and processing electronics.

The output of Electric Encoder™ is a digital serial with absolute position single turn. The combination of precision, low profile, low weight and high reliability have made Netzer Precision encoders particularly suitable to a wide variety of industrial automation applications.

### Electrical

Supply voltage	5V ± 5%
Current consumption	90 mA
Interconnection	#30 shielded cable
Cable length	5,000 mm MAX

### Environmental

EMC	IEC 6100-6-2, IEC 6100-6-4
Operating temperature	-40°C to +85°C
Storage temperature	-50°C to +100°C
Relative humidity	98% Non condensing
Shock endurance	100 g for 6ms
Vibration endurance	20g 10 – 2000 Hz
Protection	IP 40

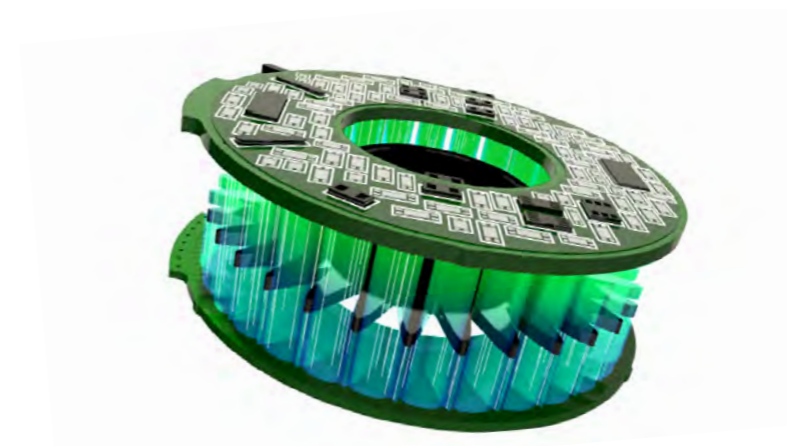



### Digital SSI Interface

Synchronous Serial Interface (SSI) is a point to point serial interface standard between a master (e.g. controller) and a slave (e.g. sensor) for digital data transmission.

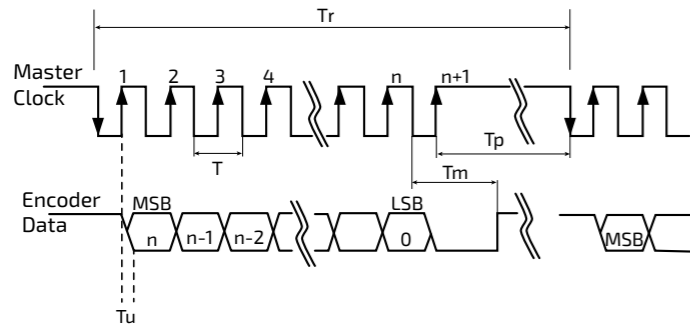

### SSI / BiSS output signal parameters

Output code	Binary
Serial output	Differential RS-422
Clock	Differential RS-422
Clock frequency	0.1 ÷ 5.0 MHz
Position update rate	35 kHz (Optional - up to 375 kHz)

### SSI / BiSS interface wires color code

Clock +	Grey	Clock
Clock -	Blue	
Data -	Yellow	Data
Data +	Green	
GND	Black	Ground
+5V	Red	Power supply

	Description	Recommendations
n	Total number of data bits	12 - 19
T	Clock period	
f = 1/T	Clock frequency	0.1 ÷ 5.0 MHz
Tu	Bit update time	90 nsec
Tp	Pause time	26 - ∞ µsec
Tm	Monoflop time	>25 µsec
Tr	Time between 2 adjacent requests	Tr > n*T + 26 µsec
fr = 1/Tr	Data request frequency	



### Digital BiSS-C Interface

BiSS - C Interface is unidirectional serial synchronous protocol for digital data transmission where the Encoder acts as "slave" transmits data according to "Master" clock. The BiSS protocol is designed in B mode and C mode (continuous mode). The BiSS-C interface as the SSI is based on RS-422 standards.

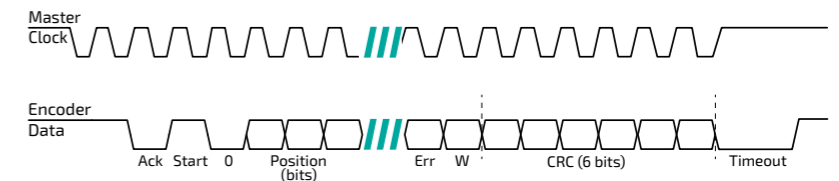

Bit #		Description	Default	Length
27	Ack	Period during which the encoder calculates the absolute position, one clock cycle	0	1/clock
26	Start	Encoder signal for "start" data transmit	1	1 bit
25	"0"	"start" bit follower	0	1 bit
8...24	AP	Absolute Position encoder data		
7	Error	Error (amplitude levels)	1	1 bit
6	Warn.	Warning (non active)	1	1 bit
0...5	CRC	The CRC polynomial for position, error and warning data is: $x^6 + x^1 + x^0$ . It is transmitted MSB first and inverted. The start bit and "0" bit are omitted from the CRC calculation.		6 bits
	Timeout	Elapse between the sequential "start" request cycle's.		25 µs

### Software tools: (SSI / BiSS - C)

Advanced calibration and monitoring options are available by using the factory supplied [Electric Encoder Explorer software](#). This facilitates proper mechanical mounting, offsets calibration and advanced signal monitoring.

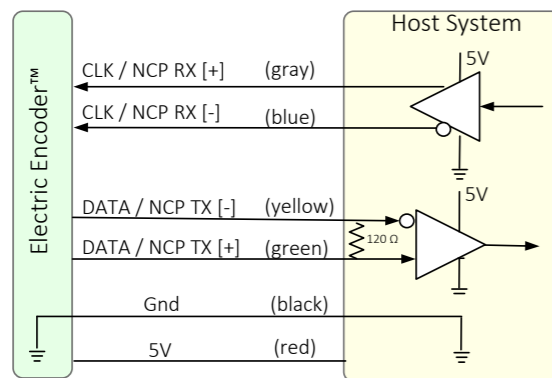

### Ordering Code

DS - 40 - S F - S 0 - n n n

DS Product line

Outer Diameter

Output

S	SSi
I	BiSS

Resolution

Code	Bit	CPR
F	17	131,072
G	18	262,144
H	19	524,288

BIT (Build In Test): optional

[ ]	None
B	BIT

EA Extended Accuracy

nnn Custom

Interconnection

0 250mm Flying leads (default)

1 500mm Flying leads

S Shielded cable

### Cable Information

Netzer Cat No.: CB 00014

Cable: 30 AWG twisted pair (3):

2 (30 AWG 25/44 tinned copper, Insulation: PFE  $\varnothing$  0.15 to  $\varnothing$  0.6  $\pm$  0.05 OD)

Temperature rating: -60 to +150 Deg C

Braided shield: Thinned copper braided 95% min. coverage

Jacket: 0.44 silicon rubber (NFA 11-A1)  $\varnothing$ 3.45  $\pm$ 0.2 OD

Pair #	Color
A1-A2	Red / Black
A3-A4	Gray / Blue
A5-A6	Green / Yellow

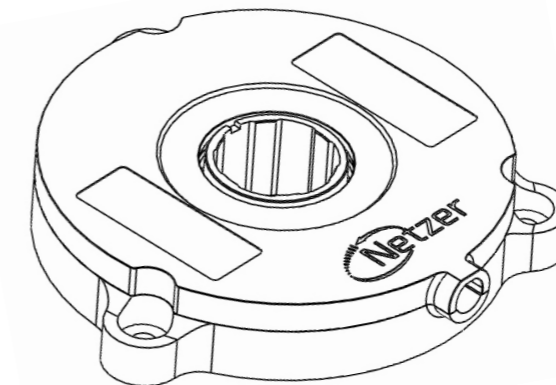
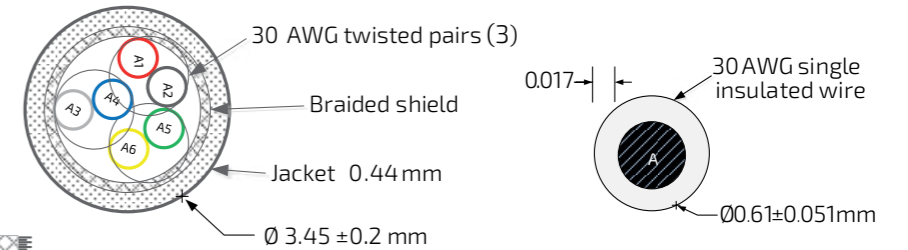
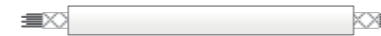

### Sold & Serviced By:

Canadian and International Sales  
**ELECTROMATE**  
877-737-8698  
sales@electromate.com  
www.electromate.com

U.S. Sales  
**SERVO2GO.com**  
877-378-0240  
sales@servo2go.com  
www.servo2go.com

### Related documents

DS-40 User Manual: Mechanical, Electrical and calibration setup.

### Optional Accessories

#### Demonstration Kit

DKIT-DS-40-SF with SSi interface

DKIT-DS-40-IF with BiSS interface

Includes, mounted encoder on rotary jig, and RS-422 to USB converter.

ICD

No	PART NUMBER	DESCRIPTION	TORQUE	INCLUDED	QTY
1	DS-40-QR	DS-40-QR Encoder		✓	1
2	EAPK008	Star washer, DIN 6798A, M2		✓	3
3		Hex socket screw, DIN 912, M2	0.2 Nm		
4		Flat washer, DIN 9021, M4 - ID 4.3		End-shaft installation kit, optional	1
5	MA-DS40-004	Star washer, DIN 6798A, M4			1
6		Hex socket low cap screw, DIN 7984, M4x6	0.3 Nm		1

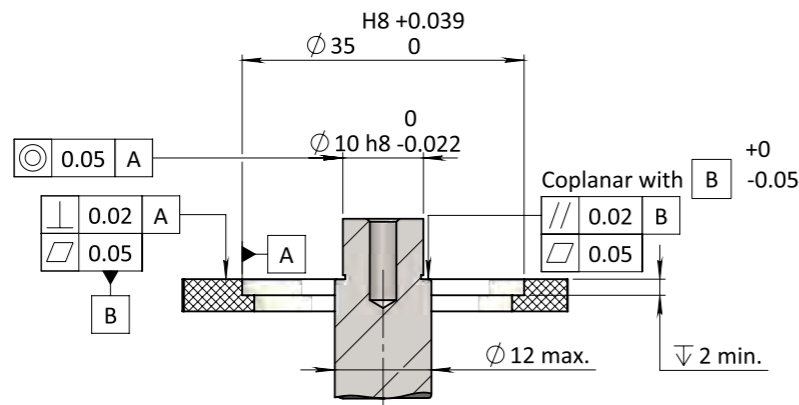

Typical mounting requirements

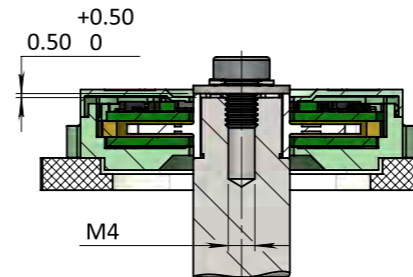

End-shaft with shoulder mounting - example

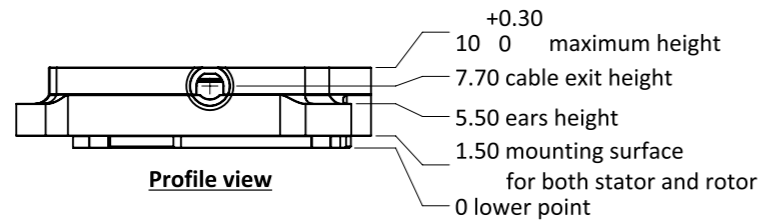
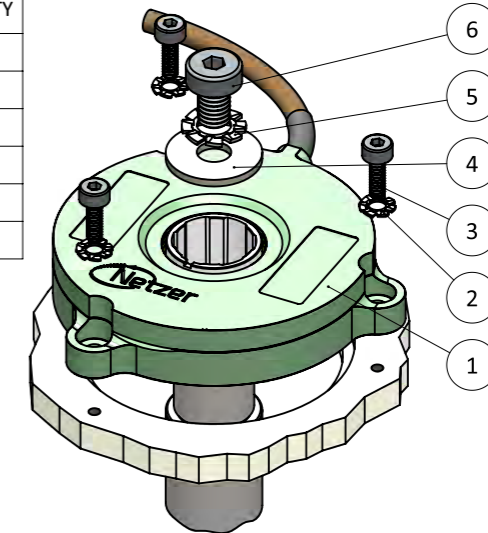

Profile view

No	PART NUMBER	DESCRIPTION	TORQUE	INCLUDED	QTY.
1	DS-40-QR	DS-40-QR Encoder		✓	1
2	EAPK008	Star washer, DIN 6798A, M2		✓	3
3		Hex socket screw, DIN 912, M2	0.2 Nm		
4	MA-DS40-002	CS056-L1-S17 Wave spring		Midshaft installation kit, optional	1
5		DS-37 retaining ring			

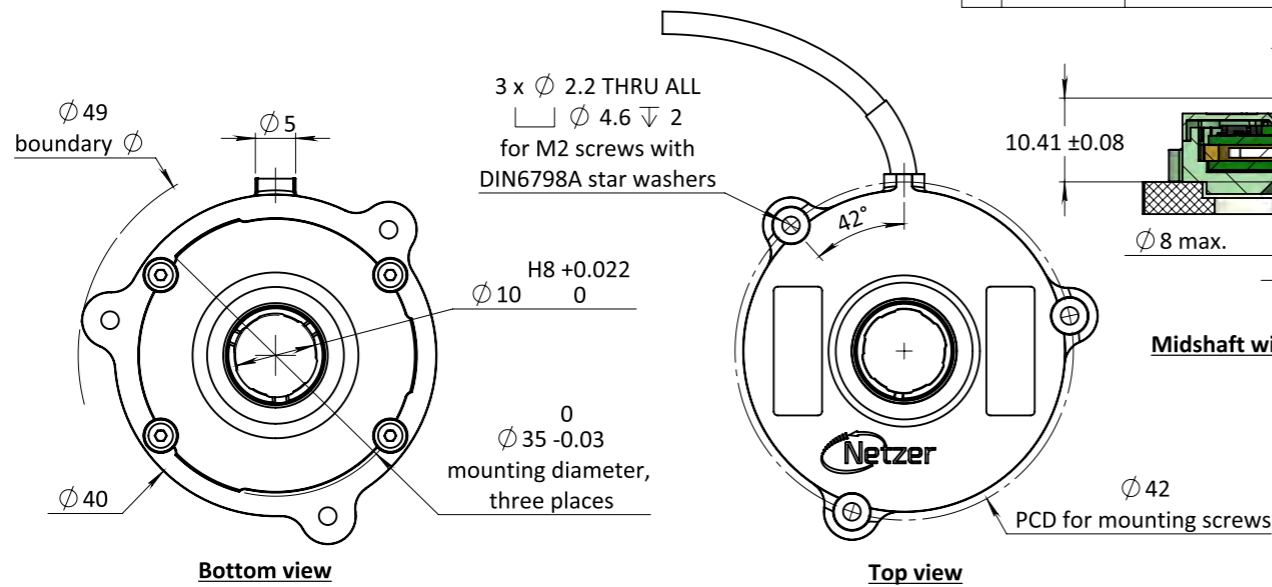
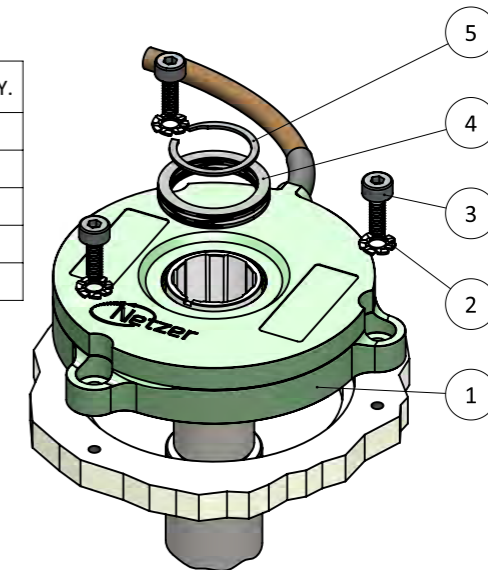

Bottom view

Top view

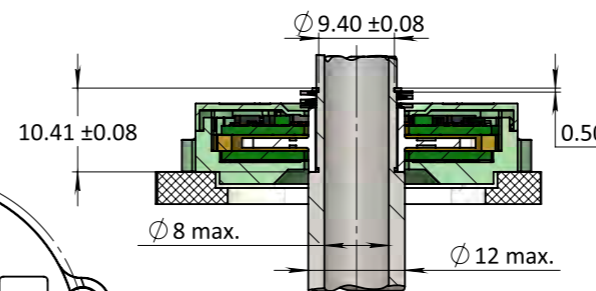

Midshaft with hollow shaft - example

Unless Otherwise Specified

Dimensions are in: mm | Surface finish: N6

Linear tolerances

0.5-4.9:  $\pm 0.05$  mm | 5-30:  $\pm 0.1$  mm

31-120:  $\pm 0.15$  mm | 121-400:  $\pm 0.2$  mm

**WARNING**



Do not use Loctite or other glues containing Cyanoacrylate. We recommend to use 3M glue - Scotch-Weld™ Epoxy Adhesive EC-2216 B/A.