

# DS-130 Absolute position, rotary Electric Encoder™

The DS-130 is a member of the DS series of Electric Encoders™, based on Netzer Precision proprietary technology. The Electric Encoder™ offers many advantages- some unparalleled

Low profile (10mm).

Hollow, floating shaft.

No bearings or other contacting elements.

High resolution and precision.

High tolerance to temperature extremes , shock, moisture, EMI, RFI and Magnetic fields.

Very low weight.

Holistic signal generation

Absolute Position over digital interfaces.

## Mechanical

Allowable mounting eccentricity	±0.1 mm
Allowable rotor axial motion	±0.1 mm
Rotor inertia	12.378 gr · mm <sup>2</sup>
Total weight	65 gr
Outer Ø /Inner Ø/ Height	130 / 90 / 10 mm
Material (stator, rotor)	Ultem™ polymer

## Electrical

Supply voltage	5V ± 5%
Interconnection	Shielded cable or
Cable Length	1,500 mm MAX

## Environmental

EMC	IEC 6100-6-2, IEC 6100-6-4
Operating temperature range	Digital: -40°C to +85°C
Relative humidity	98% Non condensing
Shock endurance	100 g for 11 ms
Vibration endurance	20 g 10 – 2000 Hz
Protection	IP 40

## Characteristics

Angular resolution	19 bits ; 524,288 CPR
Static error	< 10 mDeg
Maximum operational speed	750 rpm
Measurement range	Unlimited rotation
Power On- Max. operational speed	3.3 RPM , <=20°/sec
Build In Test BIT	Optional

The Electric Encoder™ is unique in being holistic, i.e., its output reading is the averaged outcome of the whole area of the rotor , This feature makes the Electric Encoder™ forgiving to mounting tolerances, ball bearing wander etc.

The absence of components such as ball bearings , flexible couplers, glass disc, light sources and detectors, along with very low power consumption makes the Electric Encoder™ virtually failure free.

The internally shielded, DC operated Electric Encoder™ includes an electric field generator, a field receiver, a sinusoidal shaped dielectric rotor, and processing electronics.

The output signals of Electric Encoder™ are analog Sine / Cosine representing the rotation angle. The digital outputs are obtained by further processing- which may be either internal or external to the encoder.

The combination of precision, low profile, low weight and high reliability have made Netzer Precision encoders particularly suitable to a wide variety of critical applications including, but not limited to medical equipment and aerospace.

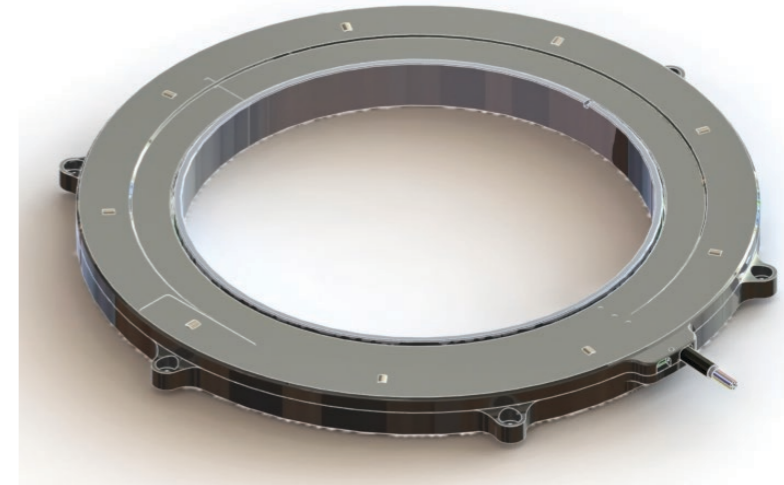



# DS-130 Absolute position, rotary Electric Encoder™

Toll Free Phone (877) SERV098  
 Toll Free Fax (877) SERV099  
 www.electromate.com  
 sales@electromate.com



## Digital SSI Interface

Synchronous Serial Interface (**SSI**) is a point to point serial interface standard between a master (e.g. controller) and a slave (e.g. sensor) for digital data transmission.

SSi / BiSS Output signal parameters	
Signal latency	~250 μSec
Output code	Binary
Serial output	Differential RS-422
Clock	Differential RS-422
Clock Frequency	0.5 ÷ 2.0 MHz
Position update rate (Max)	30 KHz
Current consumption	180 mA
<b>SSi</b>	
Monoflop time	25 μSec



## Digital BiSS-C Interface

**BiSS – C** Interface is unidirectional serial synchronous protocol for digital data transmission where the Encoder acts as “slave” transmits data according to “Master” clock. The BiSS protocol is designed in B mode and C mode (continuous mode) .The BiSS-C interface as the SSI is based on RS-422 standards.

SSi / BiSS interface wires color code		
Clock +	Grey	Clock
Clock -	Blue	
Data -	Yellow	Data
Data +	Green	
GND	Black	Ground
+5V	Red	Power supply

### Software tools: (SSi / BiSS- C)

Advanced calibration and monitoring options are available by using the factory supplied **Electric Encoder Explorer** software, This facilitates proper mechanical mounting , offsets calibration and advanced signal monitoring.

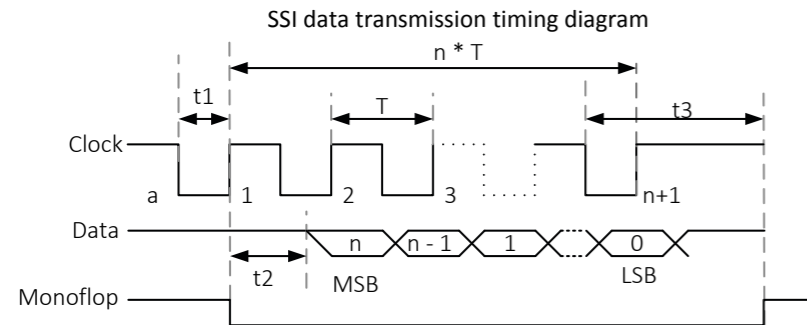
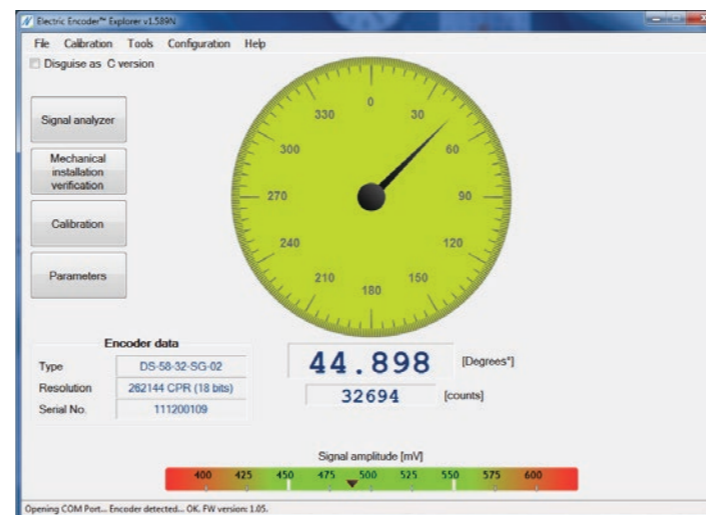

### BiSS-C data transmission timing diagram

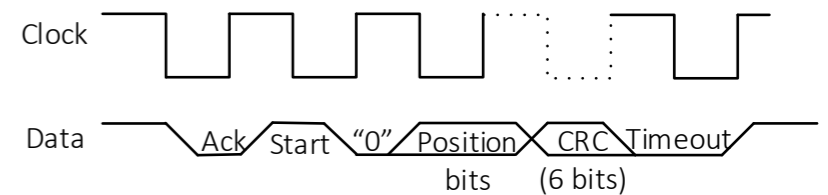

	Description	Recommendations
n	Total number of data bits	
T	Clock period (sec)	User defined
1/T	Clock frequency 0.5 ÷ 2.0 MHz (user defined)	2.0 MHz
t1	Minimum time required for the encoder to freeze data and preset the shift registers before receiving the first rising edge to prompt the MSB	T/2
t2	Data transmission delay (increases with cable length)	“0” on standard cable length
t3	Required delay to refresh position data between subsequent position	>25 μSec

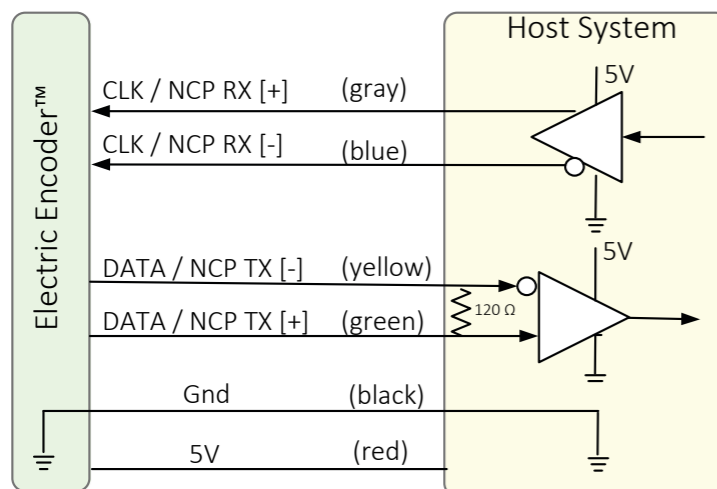

bit #		Description	De- fault	Length
27	Ack	Period during which the encoder calculates the absolute position , one clock cycle	0	1/clock
26	Start	Encoder signal for “start” data transmit	1	1 bit
25	“0”	“start” bit follower	0	1 bit
6...24	AP	Absolute Position encoder data		
0...5	CRC	The CRC polynomial for position, error and warning data is: $x^6 + x^1 + x^0$ . It is transmitted MSB first and inverted. The start bit and “0” bit are omitted from the CRC calculation.		
	Time-out	Elapse between the sequential “start” request cycle’s.		25 μs



# DS-130 Absolute position, rotary Electric Encoder™

Toll Free Phone (877) SERV098  
 Toll Free Fax (877) SERV099  
[www.electromate.com](http://www.electromate.com)  
[sales@electromate.com](mailto:sales@electromate.com)

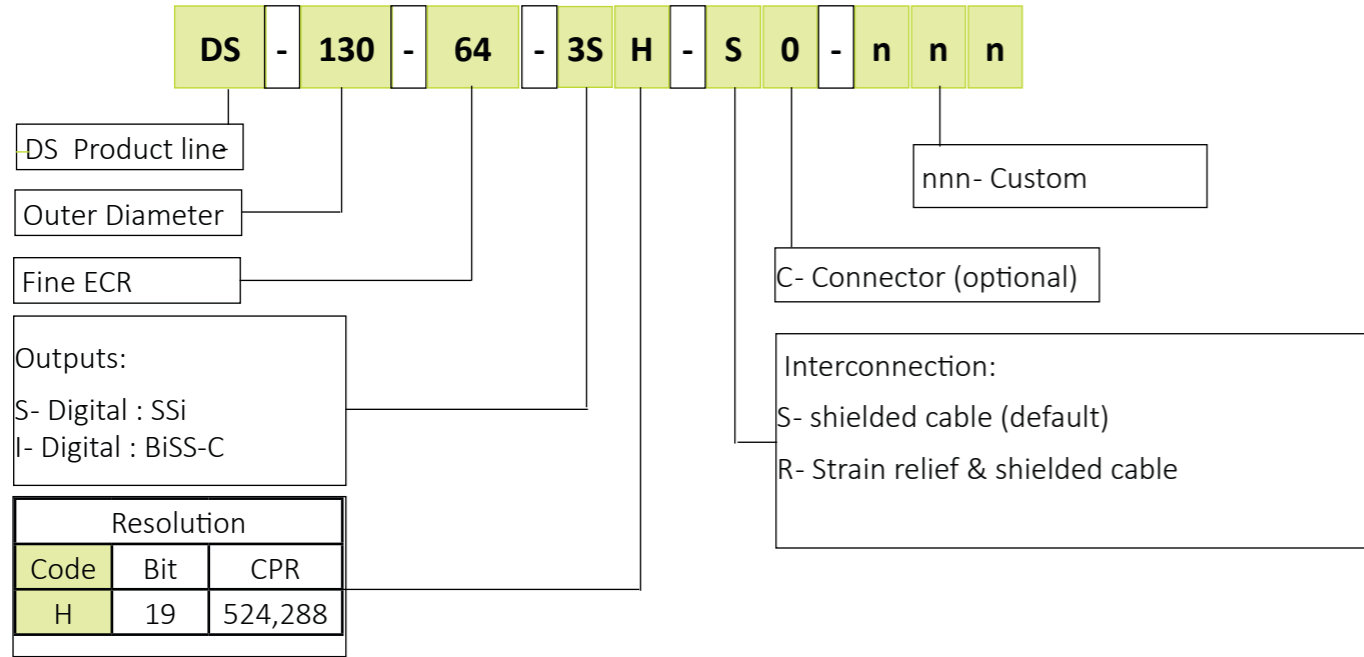

**Netzer Cat No.: CB-00014**  
**Provider:** Ray-Q USA. wire CAT No: RQ213210  
**Cable:** 30 AWG twisted pair (3) :2 (30 AWG 25/44 finned copper , 0.15 PFE to  $\varnothing 0.6 \pm 0.05$  OD).  
**Temperature rating:** -60 to +150 Deg C.  
**Braided shield:** Thinned copper braided 95% min. coverage.  
**Jacket:** 0.45 silicon rubber jacket  $\varnothing 3.45 \pm 0.2$  OD

Pair #	Color
1	Red / Black
2	Gray / Blue
3	Green / Yellow

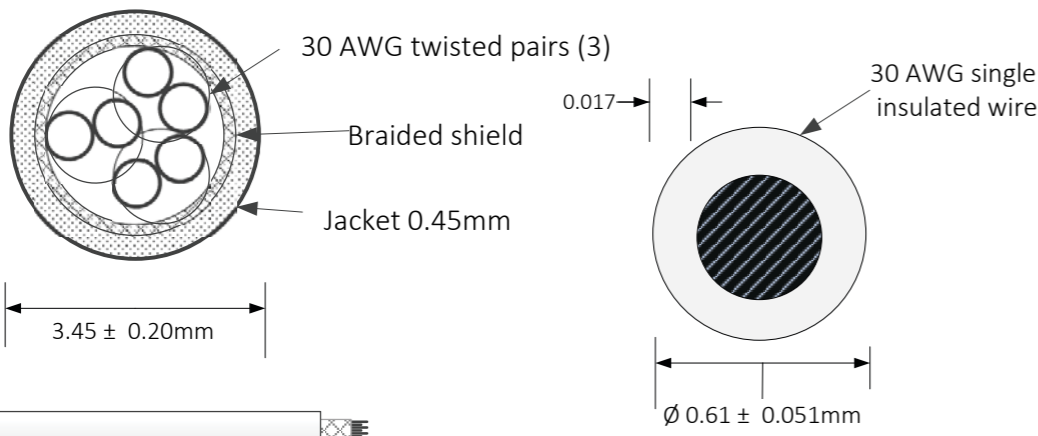

**Related documents:**

**DS-130 User Manual :** Mechanical , Electrical and calibration setup.

**Demonstration Kit:**

**DS-130DKIT-01:** Includes ,mounted encoder on rotary jig , and RS-422 to USB converter.

# DS-130 Absolute position, rotary Electric Encoder™

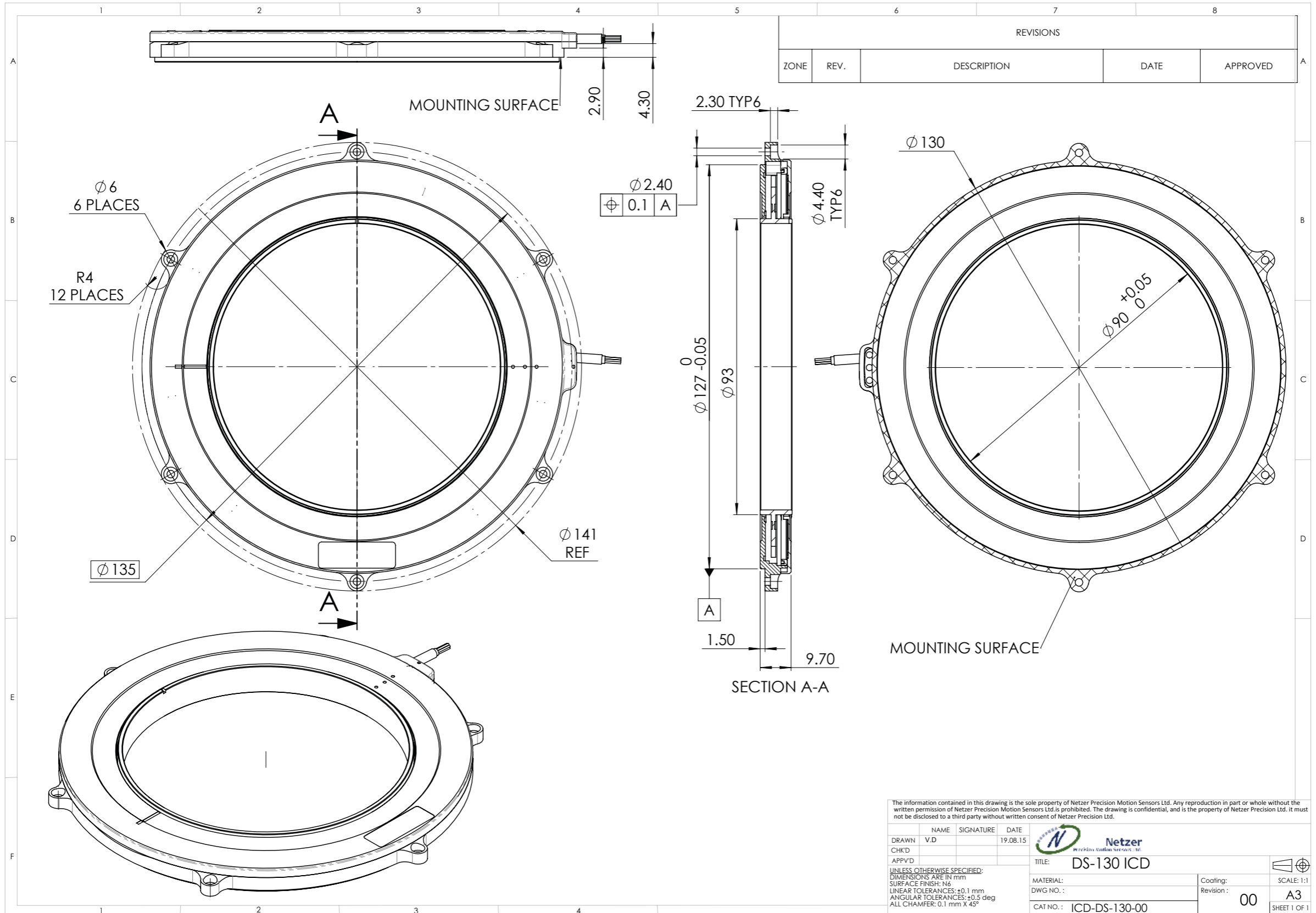



# DS-130 Absolute position, rotary Electric Encoder™

