

# Temposonics®

Magnetostrictive, Absolute, Non-contact  
Linear-Position Sensors



## R-Series Models RP and RH

EtherCAT® Industrial Ethernet Interface

Document Part Number  
551074 Revision B

### Data Sheet



Model RP Profile-style position sensor



Model RH Rod-style position sensor

#### FEATURES

- Linear, Absolute Measurement
- LEDs For Sensor Diagnostics
- Superior Accuracy, Resolution down to 1  $\mu\text{m}$
- Non-Contact Sensing Technology
- Non-Linearity Less Than 0.01%
- Repeatability Within 0.001%
- Direct EtherCAT Interface, Position + Velocity
- 100  $\mu\text{s}$  Position / Velocity Update Time, Regardless of Overall Stroke Length

#### BENEFITS

- Rugged Industrial Sensor
- Position + Velocity Measurements For Up to 20 Magnets

#### APPLICATIONS

- Continuous Operation In Harsh Industrial Conditions
- High Pressure Conditions
- For Accurate, High-Speed, Simultaneous Multi-Position and Velocity Measurements

#### TYPICAL INDUSTRIES

- Factory Automation
- Fluid Power
- Plastic Injection and Blow Molding
- Material Handling and Packaging

#### Time-based Magnetostrictive position sensing principle

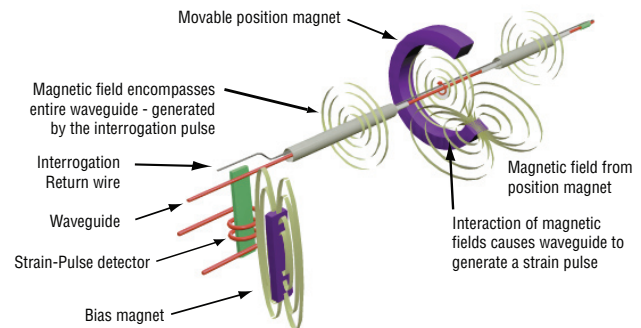

#### Benefits of Magnetostriction

Temposonics linear-position sensors use the time-based magnetostrictive position sensing principle developed by MTS. Within the sensing element, a sonic-strain pulse is induced in a specially designed magnetostrictive waveguide by the momentary interaction of two magnetic fields. One field comes from a moveable permanent magnet that passes along the outside of the sensor. The other field comes from an "interrogation" current pulse applied along the waveguide. The resulting strain pulse travels at sonic speed along the waveguide and is detected at the head of the sensing element.

The position of the magnet is determined with high precision and speed by accurately measuring the elapsed time between the application of the interrogation pulse and the arrival of the resulting strain pulse with a high-speed counter. The elapsed time measurement is directly proportional to the position of the permanent magnet and is an absolute value. Therefore, the sensor's output signal corresponds to absolute position, instead of incremental, and never requires recalibration or re-homing after a power loss. Absolute, non-contact sensing eliminates wear, and guarantees the best durability and output repeatability.

Sold & Serviced By:



Toll Free Phone (877) SERV098  
Toll Free Fax (877) SERV099  
www.electromate.com  
sales@electromate.com

Product overview

Temposonics R-Series EtherCAT sensors represent MTS Sensors’ development and product offering in high-speed networked position feedback. EtherCAT (Ethernet for Control Automation Technology) is a unique interface developed by Beckhoff Automation and is supported by the EtherCAT Technology Group (ETG). This interface is used for industrial Ethernet, providing the fastest, most deterministic industrial networking solution possible using the base Ethernet

physical layer. By using this format, coupled with our high speed networked sensing capability, machine builders and automation engineers will be able to overcome bandwidth and node limitation issues found with other commercially available industrial networks.

Product specifications

Parameters	Specifications
<b>OUTPUT</b>	
<b>Measured output variables:</b>	Simultaneous multi-position and velocity measurements up to 20 magnets or up to 5 magnets when using high-speed update (for EtherCAT distributed clock mode). Option for acceleration measurements up to 2 magnets.
<b>Resolution:</b>	1 to 1000 µm selectable
<b>Update time:</b>	100 µs min. (high speed update feature is active when the controller’s loop time is less than the sensor’s measurement cycle time)
<b>Non-linearity:</b>	< ± 0.01% full stroke (minimum ± 50 µm) (Linearity Correction Option (LCO) available)
<b>Repeatability:</b>	< ± 0.001% full stroke (minimum ± 2.5 µm)
<b>Hysteresis:</b>	< 4 µm
<b>Outputs:</b>	<b>Interface:</b> EtherCAT <b>Data format:</b> EtherCAT 100 Base-Tx, fast Ethernet <b>Data transmission rate:</b> 100 Mbit/s max.
<b>Stroke length:</b>	<b>Range (Profile style):</b> 25 mm to 5080 mm (1 in. to 200 in.) <b>Range (Rod style):</b> 25 mm to 7620 mm (1 in. to 300 in.) <b>Range (Flexible style):</b> 255 mm to 10,060 mm (10 in. to 396 in.) (Contact Factory for longer stroke lengths.)
<b>ELECTRONICS</b>	
<b>Operating voltage:</b>	<b>+24 Vdc nominal:</b> -15% or +20% <b>Polarity protection:</b> up to -30 Vdc <b>Over voltage protection:</b> up to 36 Vdc <b>Current drain:</b> 80 mA typical <b>Dielectric withstand voltage:</b> 500 Vdc (DC ground to machine ground)

Parameters	Specifications
<b>ENVIRONMENTAL</b>	
<b>Operating conditions:</b>	<b>Operating temperature:</b> -40 °C (-40 °F) to +75 °C (+167 °F) <b>Relative humidity:</b> 90% no condensation <b>Temperature coefficient:</b> < 15 ppm/ °C
<b>EMC test:</b>	<b>Emissions:</b> IEC/EN 50081-1 <b>Immunity:</b> IEC/EN 50082-2 IEC/EN 61000-4-2/3/4/6, level 3/4 criterion A, CE qualified
<b>Shock rating:</b>	100 g (single hit)/IEC standard 68-2-27 (survivability)
<b>Vibration rating:</b>	15 g / 10 to 2000 Hz / IEC standard 68-2-6
<b>Wiring</b>	
<b>Connection type:</b>	D56 option: Two female 4-pin (M12-D) plus one 4-pin male (M8) connector
<b>PROFILE STYLE SENSOR (MODEL RP)</b>	
<b>Electronic head:</b>	Aluminum housing with diagnostic LED display (LEDs located beside connectors)
<b>Sealing:</b>	IP 65
<b>Sensor extrusion:</b>	Aluminum (Temposonics profile style)
<b>Mounting:</b>	Any orientation. Adjustable mounting feet or T-slot nut (M5 threads) in bottom groove
<b>Magnet types:</b>	Captive-sliding magnet or open-ring magnet
<b>ROD STYLE SENSOR (MODEL RH)</b>	
<b>Electronic head:</b>	Aluminum housing with diagnostic LED display (LEDs located beside connectors)
<b>Sealing:</b>	IP 67
<b>Sensor rod:</b>	304L stainless steel
<b>Operating pressure:</b>	350 bar static, 690 bar peak (5000 psi static, 10,000 psi peak)
<b>Mounting:</b>	Any orientation. Threaded flange M18 x 1.5 or 3/4 - 16 UNF-3A
<b>Typical mounting torque:</b>	45 N-m (33 ft. - lbs.)
<b>Magnet types:</b>	Ring magnet, open-ring magnet, or magnet float

Enhanced monitoring and diagnostics

SENSOR STATUS AND DIAGNOSTIC DISPLAY



Integrated diagnostic LEDs (green/red), located beside sensor connectors (see 'Figure 1'), provide basic visual monitoring for normal sensor operation and troubleshooting. Diagnostic display LEDs indicate four modes described in 'Table 1. Diagnostic display indicator modes'

Figure 1. R-Series sensor Integrated diagnostic LEDs

<b>Status LED (Green)</b>	Off:	Initializing
	On:	Normal function
	Flashing:	Various flashing codes show different operational status
<b>Error LED (Red)</b>	Off:	Normal function
	On:	missing magnet
	Flashing:	Supply voltage beyond limits (high or low)
<b>IN Port LED (Green)</b>	Off:	No link
	On:	Link detected
	Flashing:	Traffic
<b>OUT Port LED (Green)</b>	Off:	No link
	On:	Link detected
	Flashing:	Traffic

Table 1. Diagnostic display indicator modes

EtherCAT interface

EtherCAT is an open field bus system which is based on Ethernet technology, (IEEE 802.3), with a high data rate and short response time, resulting in very good real-time performance. It is standardized in the IEC/PAS 62407 and is part of the ISO 15745-4 standard. The EtherCAT protocol is also being integrated into the IEC 61158, IEC 61784, and IEC 61800-7 standards.

The Temposonics EtherCAT sensor is connected as a slave device, and as such, fulfils all the requirements of the EtherCAT field bus system. Adding the sensor to an EtherCAT bus system is very easy. The system manager (e.g. TwinCAT from Beckoff Automation) gets all the parameters of the sensor from the XML file, available from the MTS website at <http://www.mtssensors.com>. There are no adjustments necessary on the sensor itself. For some applications, optimum system performance is obtained using the sensor's high speed updates, up to 10 kHz, by synchronizing to the EtherCAT's 'distributed clock mode' (available on the "E101" sensor output option).

Operation modes and output

There are two operation modes available:

E101 - Fast update position and velocity:

- Designed for high-speed motion control
- Up to 5 simultaneous magnet measurements
- 100µs update rate, (independent of stroke length)

E102 Multi-magnet position and velocity:

- Designed for gauging systems having many magnet positions
- Up to 20 simultaneous magnet measurements
- Standard update rates, (stroke length dependent)

When using multiple magnets, the minimum allowed distance between magnets is 76 mm (3 in.) to maintain proper sensor output (see 'Figure 2').

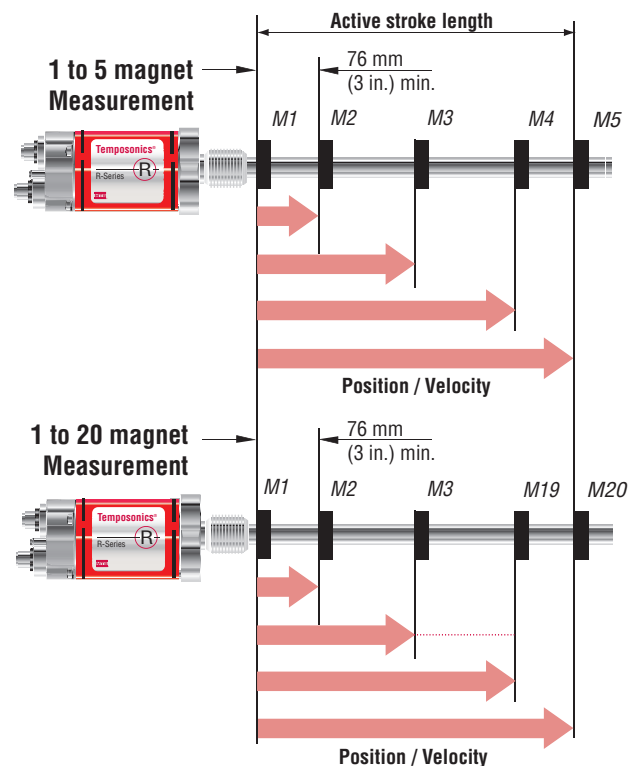

Figure 2. Single to multi-magnet output diagram

LINEARITY CORRECTION OPTION (LCO)

The Linearity Correction Option (LCO) provides improved sensor output accuracy. For most stroke lengths linearity accuracy is improved up to a factor of 5 resulting in deviations from actual position of less than ± 20 µm (0.0008 in.). For stroke lengths over 5000 mm (197 in.), the linearity accuracy is improved up to factor of 10. Selecting the sensor style and magnet is important (both must be matched together). Contact the factory for assistance when designing for the LCO in your application.

Model RP profile-style sensor dimension references

**MODEL RP, PROFILE-STYLE SENSOR WITH CAPTIVE-SLIDING MAGNET**

Drawing is for reference only, contact applications engineering for tolerance specific information.

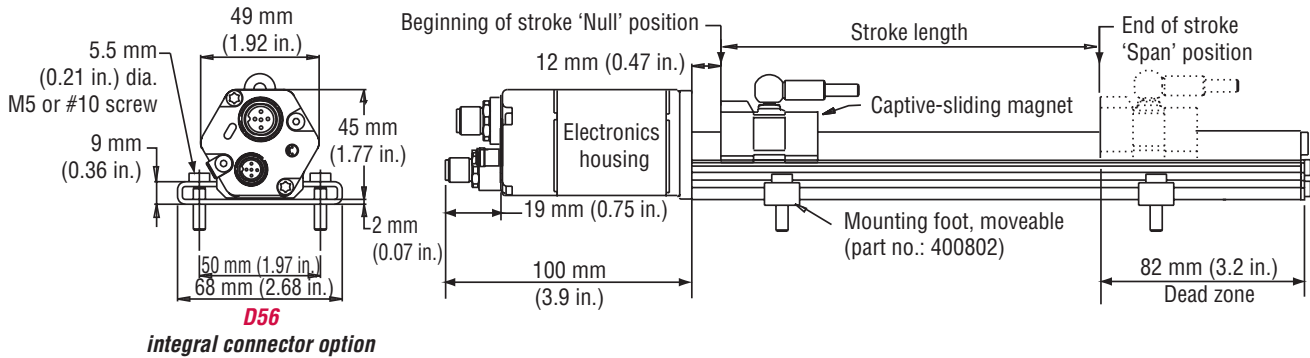

Figure 3. R-Series Model RP Profile-style sensor dimension reference (Shown with the **D56** connector option)

**MODEL RP, PROFILE-STYLE SENSOR WITH OPEN-RING MAGNET**

Drawing is for reference only, contact applications engineering for tolerance specific information.

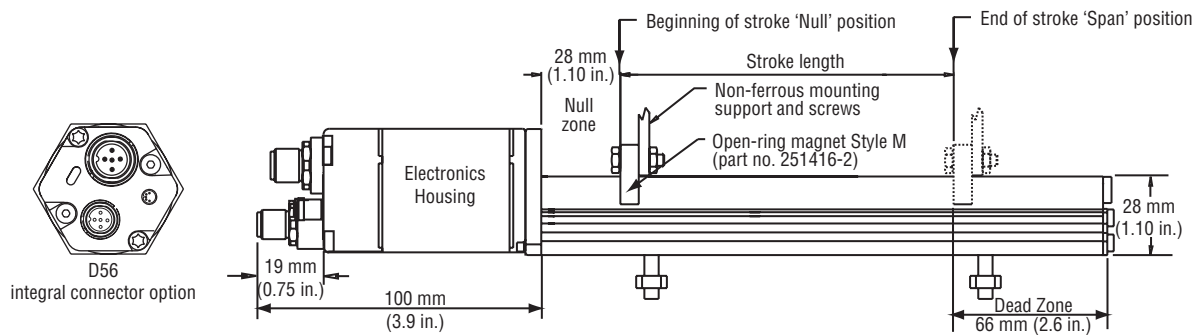

Figure 4. R-Series Model RP Profile-style sensor dimension reference (Shown with the **D56** connector option)

Standard magnet selections (Model RP)

SELECTION OF POSITION MAGNETS

A choice of two magnet mounting configurations are available with the profile-style sensor; A 'captive-sliding' magnet, *Styles S or V* or an 'open-ring' magnet, *Style M*. Captive-sliding magnets utilize slide bearings of special material that reduce friction, and if required, help mitigate dirt build up. The slide bearings are designed to operate dry, requiring no external lubrication or maintenance.

The *Style M* 'open-ring' magnet mounts on the moving machine part and travels just above the sensor's profile extrusion. The open-ring magnet requires a minimum distance away from ferrous metals to allow proper sensor output. It must be mounted using non-ferrous screws and a non-ferrous support bracket, or utilize a non-ferrous spacer of at least 5 mm (0.2 in.) thickness.

POSITION MAGNET SELECTIONS

(Drawing dimensions are for reference only)

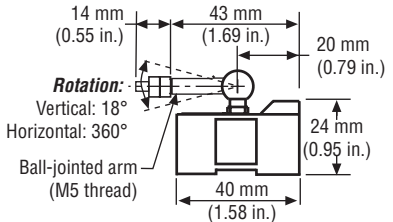
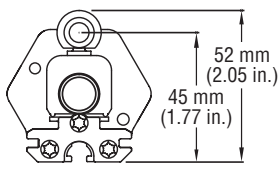
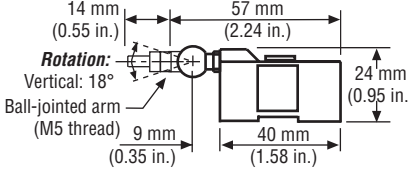
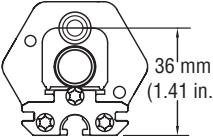
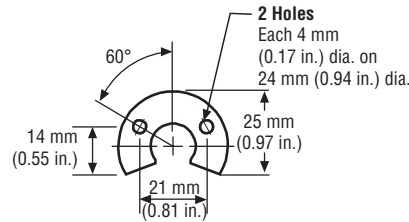
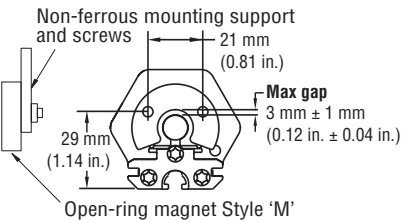
Magnet dimensions	Mounted magnet dimensions	Description	Part number
		<p><b>Captive-sliding magnet, Style S</b> For Model RP profile-style sensor</p>	252182
		<p><b>Captive-sliding magnet, Style V</b> For Model RP profile-style sensor</p>	252184
		<p><b>Open-ring magnet, Style M</b> I.D.: 13.5 mm (0.53 in.) O.D.: 33 mm (1.29 in.) Thickness: 8 mm (0.31 in.) Operating temperature: - 40 °C to 100 °C</p>	251416-2

**Sensor mounting**

**MODEL RP PROFILE-STYLE SENSOR MOUNTING** *flexible installation in any position!*

Temposonics Model RP profile-style sensors offer two basic mounting methods; side grooves for use with mounting feet or a bottom groove that accepts special T-Slot nuts. Both the mounting feet and T-Slot nuts can be positioned along the sensor extrusion to best secure the sensor for each particular application.





**Notes:**

1. Model RP sensors include two mounting feet (part no. 400802) for sensors stroke lengths up to 1250 mm (50 in.)
2. One additional mounting foot is included for stroke lengths over 1250 mm (50 in.) and for each additional 500 mm (20 in.), thereafter.
3. MTS recommends using 10-32 cap screws (*customer supplied*) at a maximum torque of 44 in. lbs. when fastening mounting feet.

**Profile-Style sensor mounting and installation reference**

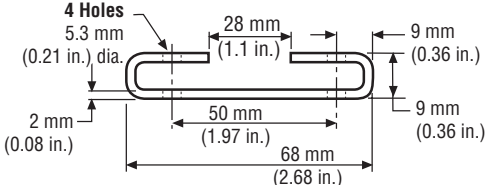
**Mounting method**

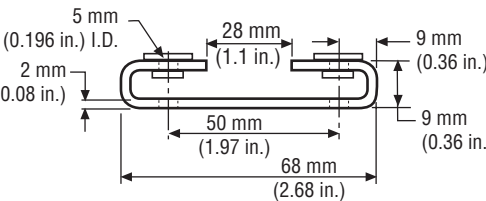
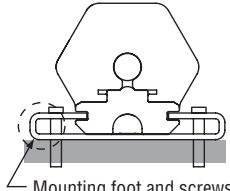
**Part number**

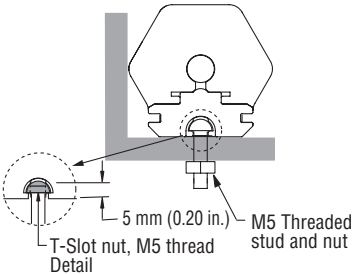
	 <p>(Width = 14.5 mm (0.57 in.))</p>	<p><b>Mounting feet, standard (304 SS)</b> Profile-style sensor mounting for sensor model RP</p>	<p>400802</p>
	 <p>(Width = 14.5 mm (0.57 in.))</p>	<p><b>Mounting feet, Insulated (304 SS)</b> Profile-style sensor mounting for sensor model RP. Nylon washers and cloth tape on the bottom provide electrical isolation.</p>	<p>252004</p>
<p>10 - 32 Cap screws Recommended (Customer supplied)</p>	 <p>Mounting foot and screws</p>	<p><b>Mounting feet and screws</b> Profile-style sensor foot installation</p>	<p>See Mounting Feet part numbers: 400802 and 252004</p>
	 <p>T-Slot nut, M5 thread Detail 5 mm (0.20 in.) M5 Threaded stud and nut</p>	<p><b>T-Slot nut</b> Nut for mounting model RP sensor. M5 thread (optional, ordered separately)</p>	<p>401602</p>

Model RH rod-style sensor dimension reference

The Temposonics R-Series rod-style sensor (Model RH) offers modular construction, flexible mounting configurations, and easy installation. The Model RH sensor is designed for mounting in applications where high pressure conditions exist (5000 psi continuous, 10,000 psi spike) such as inside hydraulic cylinders. The Model RH sensor (see 'Figure 5') may also be mounted externally in many applications.

Stroke-dependent Dead Zones:	
Stroke length:	Dead zone:
25 mm (1 in.) - 5000 mm (197 in.)	63.5 mm (2.5 in.)
5005 mm (197 in.) - 7620 mm (300 in.)	66 mm (2.6 in.)

MODEL RH, ROD-STYLE SENSOR WITH RING MAGNET (MAGNET ORDERED SEPARATELY)

Drawing is for reference only, contact applications engineering for tolerance specific information.

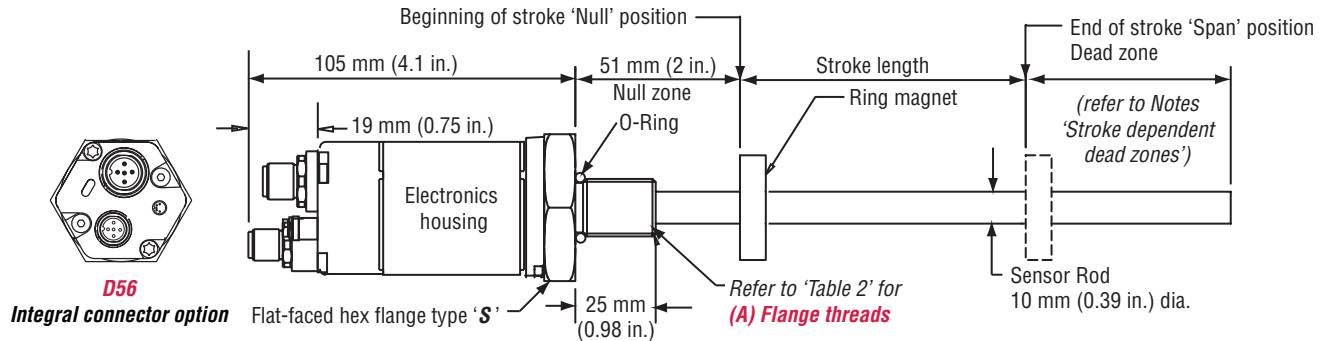

Figure 5. Model RH Rod-style sensor dimension reference (shown with **D56** integral connector options)

MODEL RH, ROD-STYLE SENSOR WITH RING MAGNET (MAGNET ORDERED SEPARATELY)

Drawing is for reference only, contact applications engineering for tolerance specific information.

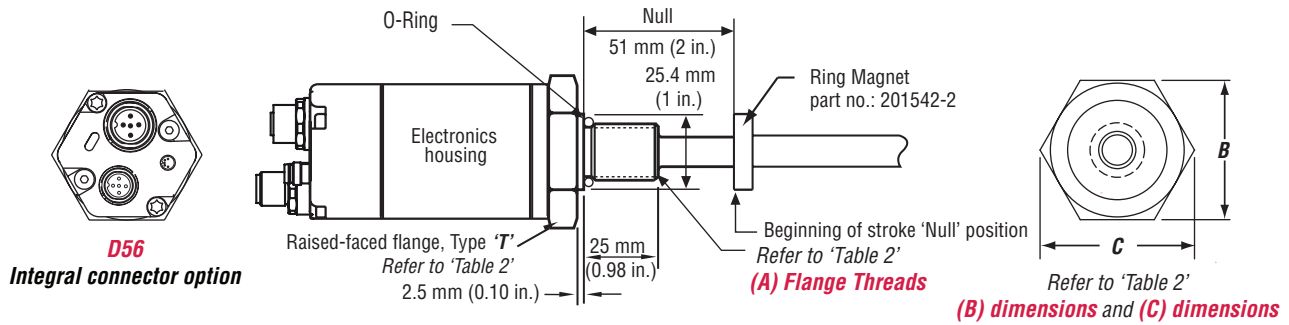

Figure 6. Model RH Rod-style sensor dimension reference (Shown with the **D56** Integral cable connection type option)

Housing style Flange type	Description	(A) Flange threads	(B) Dimensions	(C) Dimensions
<b>T</b>	US customary threads with raised-face flange	3/4" - 16 UNF-3A	1.75 in.	2 in.
<b>S</b>	US customary threads with flat-faced flange	3/4" - 16 UNF-3A	1.75 in.	2 in.
<b>M</b>	Metric threads with flat-faced flange	M18 x 1.5	46 mm	53 mm



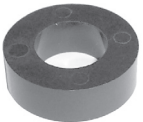
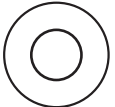

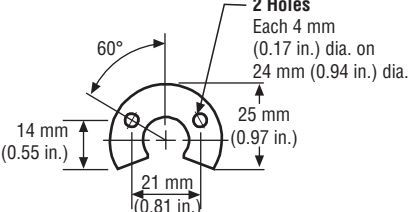

Table 2. Model RH Rod-style sensor housing style and flange type references

**Standard magnet selections (Model RH)**

Magnets must be ordered separately with Model RH position sensors. The standard ring magnet (part number 201542-2) is suitable for most applications.

**POSITION MAGNET SELECTIONS**

*(Drawing dimensions are for reference only)*

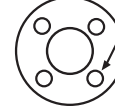
	<b>Magnet dimensions</b>	<b>Description</b>	<b>Part number</b>
	 <p><b>4 Holes</b> Each 4.3 mm (0.17 in.) dia. 90° apart on 24 mm (0.94 in.) dia.</p>	<b>Standard ring magnet</b> I.D.: 13.5 mm (0.53 in.) O.D.: 33 mm (1.3 in.) Thickness: 8 mm (0.3 in.) Operating temperature: - 40 °C to 100 °C	201542-2
		<b>Ring magnet</b> I.D.: 13.5 mm (0.53 in.) O.D.: 25.4 mm (1 in.) Thickness: 8 mm (0.3 in.) Operating temperature: - 40 °C to 100 °C	400533
	 <p><b>2 Holes</b> Each 4 mm (0.17 in.) dia. on 24 mm (0.94 in.) dia.</p> <p>60°</p> <p>14 mm (0.55 in.)</p> <p>25 mm (0.97 in.)</p> <p>21 mm (0.81 in.)</p>	<b>Open-ring magnet, Style M</b> I.D.: 13.5 mm (0.53 in.) O.D.: 33 mm (1.3 in.) Thickness: 8 mm (0.3 in.) Operating temperature: - 40 °C to 100 °C	251416-2
	 <p><b>4 Holes</b> Each 4.3 mm (0.17 in.) dia. 90° apart on 24 mm (0.94 in.) dia.</p>	<b>Magnet spacer</b> <b>(Non-ferrous, use with ring magnet</b> <b>Part number: 201542-2)</b> I.D.: 14 mm (0.56 in.) O.D.: 32 mm (1.25 in.) Thickness: 3.2 mm (0.125 in.)	400633

**MAGNET FLOAT SELECTION**

*(Drawing dimensions are for reference only)*

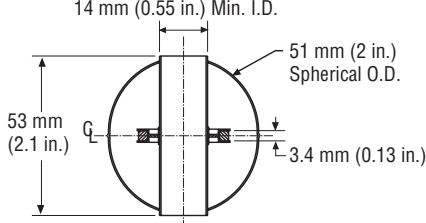
	 <p>14 mm (0.55 in.) Min. I.D.</p> <p>51 mm (2 in.) Spherical O.D.</p> <p>53 mm (2.1 in.)</p> <p>3.4 mm (0.13 in.)</p>	<b>Magnet float</b> <b>(Level sensing applications)</b> Specific gravity: 0.70 maximum Pressure: 870 psi maximum  <i>(This float is used with the Model RH Rod-style sensors for hydraulic fluid or fresh water applications only) Collar, (part no. 560777) is recommended for end of stroke "stops"</i>	251447 Collar - 560777
---	---	--	---------------------------



## PRODUCT DATA SHEET

## Model RH Rod-Style Sensor Mounting Cylinder Installation and Connections

### Model RH Rod-Style sensor mounting

#### MODEL RH SENSOR MOUNTING

The position magnet requires minimum distances away from ferrous metals to allow proper sensor output. The minimum distance from the front of the magnet to the cylinder end cap is 15 mm (0.6 in.).

The minimum distance from the back of the magnet to the piston head is 3.2 mm (0.125 in.). The non-ferrous spacer (part no.: 400633) provides this minimum distance when used along with the standard ring magnet (part no.: 201542-2).

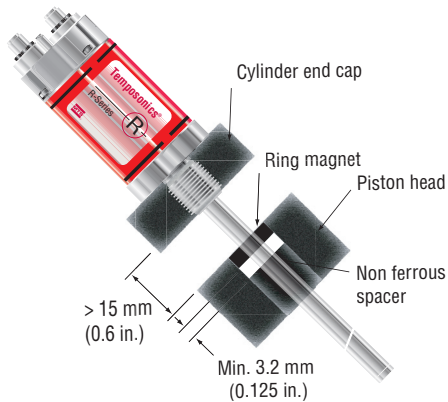

Figure 7. Model RH rod-style mounting

### Cylinder installation

When used for direct-stroke measurement in fluid cylinders, the sensor's high pressure, stainless steel rod installs into a bore in the piston head/rod assembly as illustrated. This method guarantees a long-life and trouble-free operation.

The sensor cartridge can be removed from the flange and rod housing while still installed in the cylinder. This procedure allows quick and easy sensor cartridge replacement without the loss of hydraulic pressure.

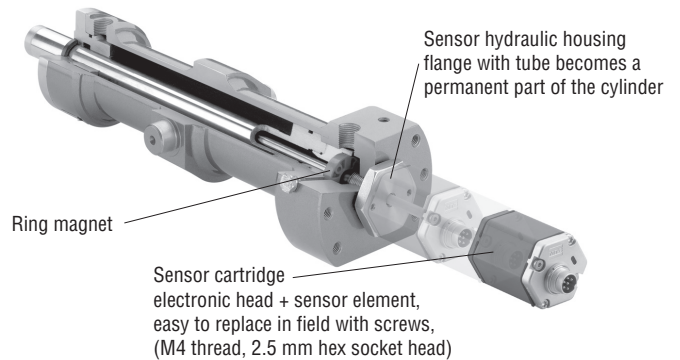
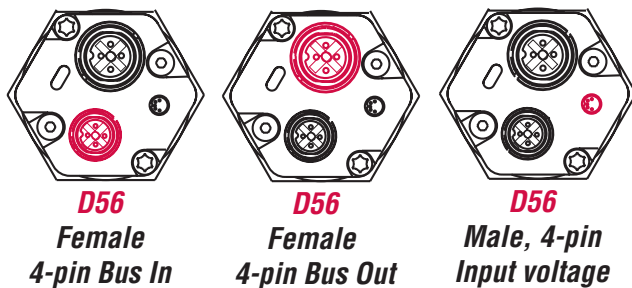

Figure 8. Fluid cylinder installation

### Connections and wiring

#### (D56) BUS CONNECTOR OPTION

D56 connector option for 'daisy chain' topologies. A separate cable is used for the supply voltage. Unused connectors should be covered by a protective cap.



#### BUS CONNECTIONS IN/OUT



Female, 4-pin (M12-D) integral connector pin-out as viewed from the end of the sensor

Pin number	Cable color	Function
1	Yellow	Tx+
2	White	Rx+
3	Orange	Tx-
4	Blue	Rx-

#### INPUT VOLTAGE



Input voltage, male, 4-pin (M8) integral connector pin-out as viewed from the end of the sensor

Pin number	Cable color	Supply voltage
1	Brown	+24 Vdc (-15/+20%)
2	White	No connection
3	Blue	DC ground (for supply)
4	Black	No connection

Sold & Serviced By:



**ELECTROMATE**

Toll Free Phone (877) SERV098  
Toll Free Fax (877) SERV099  
www.electromate.com  
sales@electromate.com

**Models RP and RH Sensors**  
**Ordering Information, Connector and Cable Assembly Options**

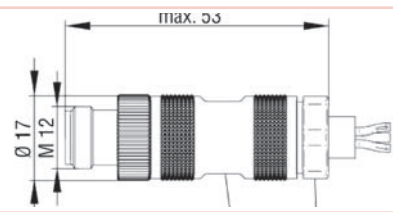

**PRODUCT DATA SHEET**

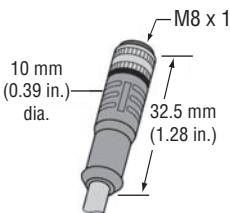
**(D56) CABLE CONNECTOR OPTIONS** *(Drawing dimensions are for reference only)*

Connector	Connector dimensions	Description	Part number
		<b>Bus Cable Connector, Male 4-pin (M12), D-coded with insulation displacement technology</b>	370523
		<b>Connector, Female 4-pin (M8) and cable with pigtail termination</b>  <i>For 24 Vdc input. Wire gage 4x0.25 mm<sup>2</sup> shielded, PUR cable jacket</i>	5 m length = 530066 10 m length = 530096 15 m length = 530093

**BUS CABLE WITH CONNECTORS** *(Drawing dimensions are for reference only)*

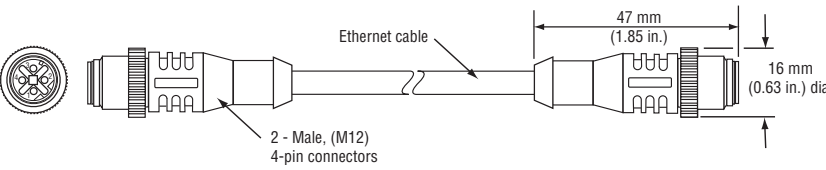
**Bus cable and connector assemblies**

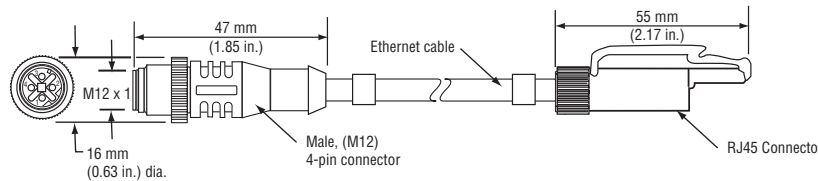
Bus cable and connector assemblies	Description	Part number
	<b>Industrial Ethernet Bus Cable, 5 m length (Cat 5e ES)</b>  <i>Assembly Includes two 4-pin (M12) connectors (D-coded) PUR cable jacket (green)</i>	530064
		
	<b>Industrial Ethernet Bus Cable, 5 m length (Cat 5e ES)</b>  <i>Assembly Includes one RJ45 connector and one 4-pin (M12) connector (D-coded) PUR cable jacket (green)</i>  <i>Cables using the RJ45 connector provide convenient sensor connection to a PC for setup and programming but are not recommended for factory floor installations.</i>	530065
		

Sold & Serviced By:



Toll Free Phone (877) SERV098  
 Toll Free Fax (877) SERV099  
[www.electromate.com](http://www.electromate.com)  
[sales@electromate.com](mailto:sales@electromate.com)

**PRODUCT DATA SHEET**

**Models RP and RH Sensors  
Ordering Information**

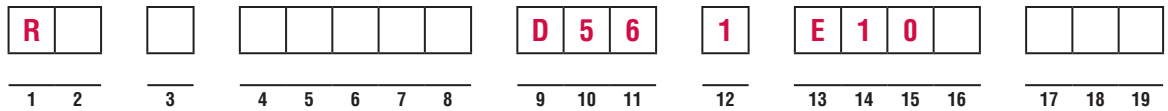

**SENSOR MODEL**

**RP** = Profile style **RH** = Hydraulic rod style **RF** = Flexible style = **R**   **1-2**

(For more information about the model RF, refer to Industrial Product Catalog, part no.: 551075)

**HOUSING STYLE**

**S** = Captive-sliding magnet with ball joint at top (part no. 252182) **V** = Captive-sliding magnet with ball joint at front (part no. 252184) **M** = Open-ring magnet (part no. 251416-2)

**Model RH rod-style sensor (magnet(s) must be ordered separately):**

**T** = US customary threads, raised-faced flange and pressure tube, standard **U** = Same as option "T", except uses fluoroelastomer seals for the electronics housing **B** = Sensor cartridge only (no flange or pressure tube, stroke length < 1830 mm (72 in.))

**S** = US customary threads, flat-faced flange and pressure tube, standard **H** = Same as option "S", except uses fluoroelastomer seals for the electronics housing

**M** = Metric threads, flat-faced flange and pressure tube, standard **V** = Same as option "M", except uses fluoroelastomer seals for the electronics housing

**Model RF Flexible housing style sensor (magnet(s) must be ordered separately):**

**S** = US customary threads, flat-faced flange **M** = Metric threads, flat-faced flange

**STROKE LENGTH**

**M** = Millimeters (Encode in 5 mm increments) =           **4-8**

**U** = Inches and tenths (Encode in 0.1 in. increments)

**Stroke Length Notes:**

1. Profile-style sensor (model RP) stroke range = 25 mm (1 in.) - 5080 mm. (200 in.)
2. Rod-style sensor (model RH) stroke range = 25 mm (1 in.) - 7620 mm (300 in.)
3. Flexible housing style sensor (model RF) stroke range = 255 mm (10 in.) - 10,060 mm (396 in.) Contact factory for longer stroke lengths.

**CONNECTION TYPE**

**D56** = Two 4-pin female (M12-D), plus one 4-pin male (M8) = **D** **5** **6** **9-11**

**Integral connector:**

**INPUT VOLTAGE**

**1** = +24 Vdc (+20% - 15%) = **1** **12**

**OUTPUT**

**E101** = EtherCAT, position and velocity, high speed updates, maximum 5 magnets = **E** **1** **0** **13-16**

**E102** = EtherCAT, position and velocity, maximum 20 magnets

**E103** = Same as option 'E101' with Linearity Correction Option (LCO)

**E104** = Same as option 'E102' with Linearity Correction Option (LCO)

**NUMBER OF MAGNETS**

For multi-position measurement only (Order additional magnets separately). = **Z**     **17-19**

**Z** = Number of magnets for output **E101** (range 02 to 05), or for output **E102** (range 02 to 20)

Sold & Serviced By:



Toll Free Phone (877) SERV098  
Toll Free Fax (877) SERV099  
www.electromate.com  
sales@electromate.com