

Temposonics®

Magnetostrictive, Absolute, Non-contact
Linear-Position Sensors



R-Series Models RP and RH DeviceNet Output

Document Part Number
550651 Revision F

Data Sheet



Model RP Profile-style position sensor

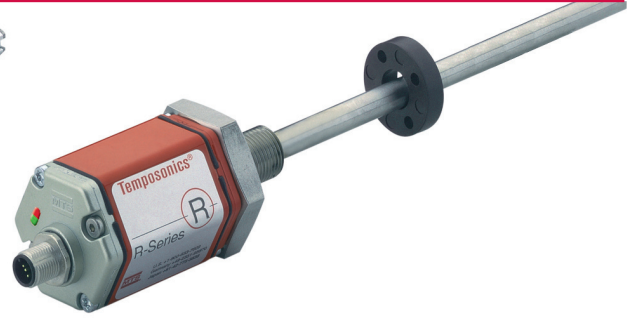

Model RH Rod-style position sensor

FEATURES

- Linear, Absolute Measurement
- LEDs For Sensor Diagnostics
- Superior Accuracy, Resolution down to 2 μm
- Non-Contact Sensing Technology
- Non-Linearity Less Than 0.01%
- Repeatability Within 0.001%
- Direct DeviceNet Output

BENEFITS

- Rugged Industrial Sensor
- Cost-effective Communications Network linking Industrial Measurement and Control Devices
- Interface Up to 64 Devices using one cable

APPLICATIONS

- Continuous Operation In Harsh Industrial Conditions
- High Pressure Conditions

TYPICAL INDUSTRIES

- Factory Automation
- Fluid Power
- Plastic Injection and Blow Molding
- Material Handling and Packaging

Time-based Magnetostrictive position sensing principle

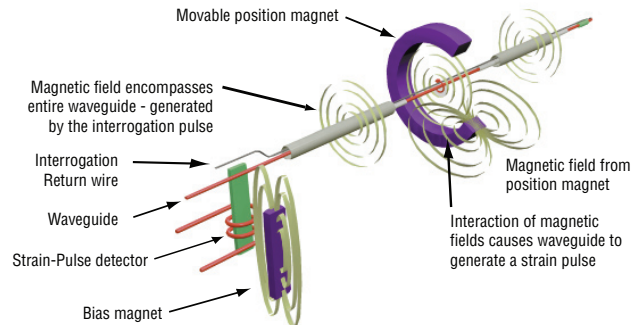

Benefits of Magnetostriction

Temposonics linear-position sensors use the time-based magnetostrictive position sensing principle developed by MTS. Within the sensing element, a sonic-strain pulse is induced in a specially designed magnetostrictive waveguide by the momentary interaction of two magnetic fields. One field comes from a moveable permanent magnet that passes along the outside of the sensor. The other field comes from an "interrogation" current pulse applied along the waveguide. The resulting strain pulse travels at sonic speed along the waveguide and is detected at the head of the sensing element.

The position of the magnet is determined with high precision and speed by accurately measuring the elapsed time between the application of the interrogation pulse and the arrival of the resulting strain pulse with a high-speed counter. The elapsed time measurement is directly proportional to the position of the permanent magnet and is an absolute value. Therefore, the sensor's output signal corresponds to absolute position, instead of incremental, and never requires recalibration or re-homing after a power loss. Absolute, non-contact sensing eliminates wear, and guarantees the best durability and output repeatability.

Sold & Serviced By:



Toll Free Phone (877) SERV098
Toll Free Fax (877) SERV099
www.electromate.com
sales@electromate.com

Product overview

R-Series model RH and RP sensors are extremely robust and are ideal for continuous operation under harsh industrial conditions.

MTS offers two standard sensor housings, rod and profile extrusion. The rod housing is capable of withstanding high pressures such as those found in hydraulic cylinders.

The profile extrusion housing provides convenient mounting options and captive sliding magnets which utilize slide bearings of special material that reduce friction, and help mitigate dirt build up. The sensor head contains the active signal conditioning and a complete integrated electronics interface. Double shielding is used to ensure EMI protection for unsurpassed reliability and operating safety.

Controller Area Network (CAN) is a standard for device level communications and the foundation of fieldbus systems like DeviceNet, CANopen and CANbus. These fieldbus systems can provide high speed transmission appropriate for position indication and for motion control in industrial applications.

DeviceNet allows users to interface up to 64 devices using a single cable, thus eliminating the need for conventional methods of multiple wire runs. DeviceNet provides a way to define how, and in which priority, data will be transmitted over the network. The result is a lower complexity, cost-effective communications network linking industrial measurement and control devices. Together, the open DeviceNet protocol and the MTS “smart” R-Series sensors offer an effective, high-precision data transfer system that is well suited for industrial automation.

Product specifications

Parameters	Specifications
OUTPUT	
Measured output variable:	Position
Resolution:	2 µm or 5 µm
Update times::	0.5 ms up to 1200 mm, 1.0 ms up to 2400 mm, 2.0 ms up to 4800 mm, 4.0 ms up to 7600 mm stroke length
Non-linearity:	< ± 0.01% full stroke (minimum ± 40 µm)
Repeatability:	< ± 0.001% full stroke (minimum ± 2.5 µm)
Hysteresis:	< 4 µm
Output:	Interface: CAN-Fieldbus system ISO DIS 11898 Data protocol DeviceNet release 2.0
Baud rate, kBit/s:	500 250 125
Cable length, m:	<100 <250 <500 <i>Sensors will be supplied with ordered Baud rate which can be changed by the customer.</i>
Stroke length:	Range (Profile style): 25 mm to 5080 mm (1 in. to 200 in.) Range (Rod style): 25 mm to 7620 mm (1 in. to 300 in.) Range (Flexible style): 255 mm to 10,060 mm (10 in. to 396 in.) <i>(Contact Factory for longer stroke lengths.)</i>
ELECTRONICS	
Operating voltage:	+24 Vdc nominal: -15% or +20% Polarity protection: up to -30 Vdc Overvoltage protection: up to 36 Vdc Current drain: 90 mA typical Dielectric withstand voltage: 500 Vdc (DC ground to machine ground)

Parameters	Specifications
ENVIRONMENTAL	
Operating conditions:	Operating temperature: -40 °C (-40 °F) to +75 °C (+167 °F) Relative humidity: 90% no condensation Temperature coefficient: < 15 ppm/ °C
EMC test:	Emissions: IEC/EN 50081-1 Immunity: IEC/EN 50082-2 IEC/EN 61000-4-2/3/4/6, level 3/4 criterion A, CE qualified
Shock rating:	100 g (single hit)/IEC standard 68-2-27 (survivability)
Vibration rating:	15 g / 10 to 2000 Hz / IEC standard 68-2-6
WIRING	
Connection type:	5-pin male D51 DeviceNet connector
PROFILE STYLE SENSOR (MODEL RP)	
Electronic head:	Aluminum housing with diagnostic LED display (LEDs located beside connector/cable exit)
Sealing:	IP 65
Sensor extrusion:	Aluminum (Temposonics profile style)
Mounting:	Any orientation. Adjustable mounting feet or T-slot nut (M5 threads) in bottom groove
Magnet types:	Captive-sliding magnet or open-ring magnet
ROD STYLE SENSOR (MODEL RH)	
Electronic head:	Aluminum housing with diagnostic LED display (LEDs located beside connector/cable exit)
Sealing:	IP 67 or IP 68 for integral cable models
Sensor rod:	304L stainless steel
Operating pressure:	350 bar static, 690 bar peak (5000 psi static, 10,000 psi peak)
Mounting:	Any orientation. Threaded flange M18 x 1.5 or 3/4 - 16 UNF-3A
Typical mounting torque:	45 N-m (33 ft. - lbs.)
Magnet types:	Ring magnet, open-ring magnet, or magnet float

Sold & Serviced By:



Toll Free Phone (877) SERV098
Toll Free Fax (877) SERV099
www.electromate.com
sales@electromate.com

PRODUCT DATA SHEET

DeviceNet Protocol, Programmability, Enhanced Monitoring, Diagnostics and Model RP sensor dimension references

Enhanced monitoring and diagnostics

SENSOR STATUS AND DIAGNOSTIC DISPLAY

Integrated diagnostic LEDs (green/red), located beside sensor connector (see 'Figure 1'), provide basic visual monitoring for normal sensor operation and DeviceNet communications. Diagnostic display LEDs indicate two modes, Network and Module status as described in 'Table 1'.



Figure 1. R-Series sensor Integrated diagnostic LEDs

Network Status LED	Operation status/mode
Green	Normal function (operation mode)
Green Flashing	Waiting for instructions from DeviceNet master
Red	Initialization error
Red Flashing	No answer from DeviceNet master

Module Status LED	Operation status/mode
Green	Normal function (operation mode)
Red	Magnet not detected

Table 1. Diagnostic display indicator modes

DeviceNet protocol

R-Series models RP and RH linear-position sensors as slave devices fulfill all requirements of the CANbus (ISO 11898) standard. The sensors electronics and integrated software implement the DeviceNet protocol to convert the displacement measurements into bus oriented outputs and transfer this data directly to the controller. The DeviceNet protocol is appropriate for serial data transfer up to 500 kBit/sec.

When using the DeviceNet protocol with R-series sensors, functionality always includes but is not limited to the following:

- Position
- Error Detection
- Polling & bit-strobe communications modes

PLUG AND PLAY

R-Series sensors with DeviceNet output can be directly connected to a DeviceNet network. The plug and play design makes installation quick and easy. The sensor acts as a "slave" device that transmits its

position and status data upon request to the "master" device such as a PLC or IPC. After initial system configuration, the user is not required to have extensive knowledge concerning network timing and sensor technology to execute operations within DeviceNet environment. Sensor-specific parameters are installed into the network using the Electronic Data Sheet (EDS). To obtain the EDS, go to www.mtssensors.com.

There are only two programmable parameters, which are, the node identifier and the baud rate. If desired, a PC programming tool, such as DeviceNet Manager offered by Allen Bradley, can be used to change their values. The node identifier is factory set at node 63.

The selected baud rate is shown in the sensor's model number. Note that the sensor will only be recognized on a network running at the same baud rate.

Model RP profile-style sensor dimension references

MODEL RP, PROFILE-STYLE SENSOR WITH CAPTIVE-SLIDING MAGNET

Drawing is for reference only, contact applications engineering for tolerance specific information.

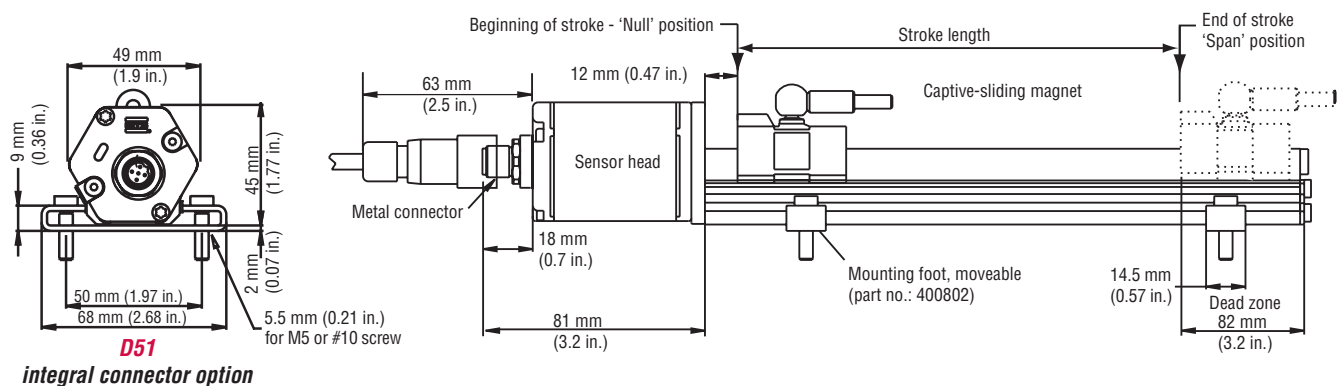

Figure 2. R-Series Model RP Profile-style sensor dimension reference (Shown with the **D51** integral connector option)

Sold & Serviced By:

ELECTROMATE

Toll Free Phone (877) SERV098

Toll Free Fax (877) SERV099

www.electromate.com

sales@electromate.com

Model RP Profile-Style Sensor Dimensions and Standard Magnet Selections

MODEL RP, PROFILE-STYLE SENSOR WITH OPEN-RING MAGNET

Drawing is for reference only, contact applications engineering for tolerance specific information.

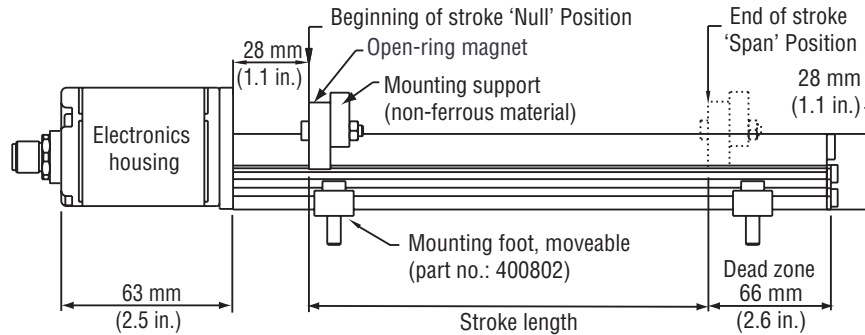

Figure 3. R-Series Model RP Profile-style sensor dimension reference (Shown with the **D51** integral connector option)

Standard magnet selections (Model RP)

SELECTION OF POSITION MAGNETS (ONE MAGNET INCLUDED WITH MODEL RP SENSOR)

A choice of two magnet mounting configurations are available with the profile-style sensor; A 'captive-sliding' magnet, *Styles S or V* or an 'open-ring' magnet, *Style M*. Captive-sliding magnets utilize slide bearings of special material that reduce friction, and if required, help mitigate dirt build up. The slide bearings are designed to operate dry, requiring no external lubrication or maintenance.

The *Style M* 'open-ring' magnet mounts on the moving machine part and travels just above the sensor's profile extrusion. The open-ring magnet requires a minimum distance away from ferrous metals to allow proper sensor output. It must be mounted using non-ferrous screws and a non-ferrous support bracket, or utilize a non-ferrous spacer of at least 5 mm (0.2 in.) thickness.

POSITION MAGNET SELECTIONS (One Magnet included with each Model RP sensor)

(Drawing dimensions are for reference only)

Magnet dimensions	Mounted magnet dimensions	Description	Part number
		Captive-sliding magnet, Style S For Model RP profile-style sensor	252182
		Captive-sliding magnet, Style V For Model RP profile-style sensor	252184
		Open-ring magnet, Style M I.D.: 13.5 mm (.53 in.) O.D.: 33 mm (1.29 in.) Thickness: 8 mm (0.31 in.) Operating temperature: - 40 °C to 100 °C	251416-2

Sold & Serviced By:



Toll Free Phone (877) SERV098
Toll Free Fax (877) SERV099
www.electromate.com
sales@electromate.com

Sensor mounting

MODEL RP PROFILE-STYLE SENSOR MOUNTING *flexible installation in any position!*

Temposonics Model RP profile-style sensors offer two basic mounting methods; side grooves for use with mounting feet or a bottom groove that accepts special T-Slot nuts. Both the mounting feet and T-Slot nuts can be positioned along the sensor extrusion to best secure the sensor for each particular application.





Notes:

1. Model RP sensors include two mounting feet, (part no. 400802) for sensors stroke lengths up to 1250 mm (50 in.)
2. One additional mounting foot is included for stroke lengths over 1250 mm (50 in.) and for each additional 500 mm (20 in.), thereafter.
3. MTS recommends using 10-32 cap screws (*customer supplied*) at a maximum torque of 44 in. lbs. when fastening mounting feet.

Profile-Style sensor mounting and installation reference

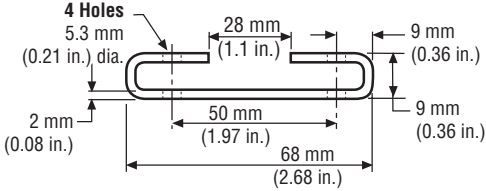
Mounting method

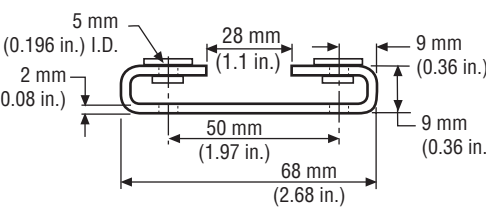
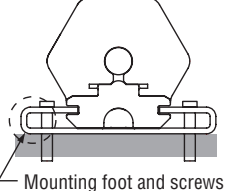
Part number

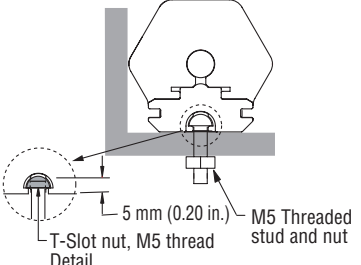
	 <p>(Width = 14.5 mm (0.57 in.))</p>	<p>Mounting feet, standard (304 SS) Profile-style sensor mounting for sensor model RP</p>	<p>400802</p>
	 <p>(Width = 14.5 mm (0.57 in.))</p>	<p>Mounting feet, Insulated (304 SS) Profile-style sensor mounting for sensor model RP. Nylon washers and cloth tape on the bottom provide electrical isolation.</p>	<p>252004</p>
<p>(10 - 32 Cap screws) Recommended (Customer supplied)</p>	 <p>Mounting foot and screws</p>	<p>Mounting feet and screws Profile-style sensor foot installation</p>	<p>See Mounting Feet part numbers: 400802 and 252004</p>
	 <p>T-Slot nut, M5 thread Detail 5 mm (0.20 in.) M5 Threaded stud and nut</p>	<p>T-Slot nut Nut for mounting model RP sensor. (M5 threaded) using bottom groove</p>	<p>401602</p>

Model RH rod-style sensor dimension reference

The Temposonics R-Series rod-style sensor (Model RH) offers modular construction, flexible mounting configurations, and easy installation. The Model RH sensor is designed for mounting in applications where high pressure conditions exist, (5000 psi continuous, 10,000 psi spike), such as inside hydraulic cylinders. The Model RH sensor (see Figure 4) may also be mounted externally in many applications.

Stroke-dependent Dead Zones:	
Stroke length:	Dead zone:
25 mm (1 in.) - 5000 mm (197 in.)	63.5 mm (2.5 in.)
5005 mm (197 in.) - 7620 mm (300 in.)	66 mm (2.6 in.)

MODEL RH, ROD-STYLE SENSOR WITH RING MAGNET (MAGNET ORDERED SEPARATELY)

Drawing is for reference only, contact applications engineering for tolerance specific information.

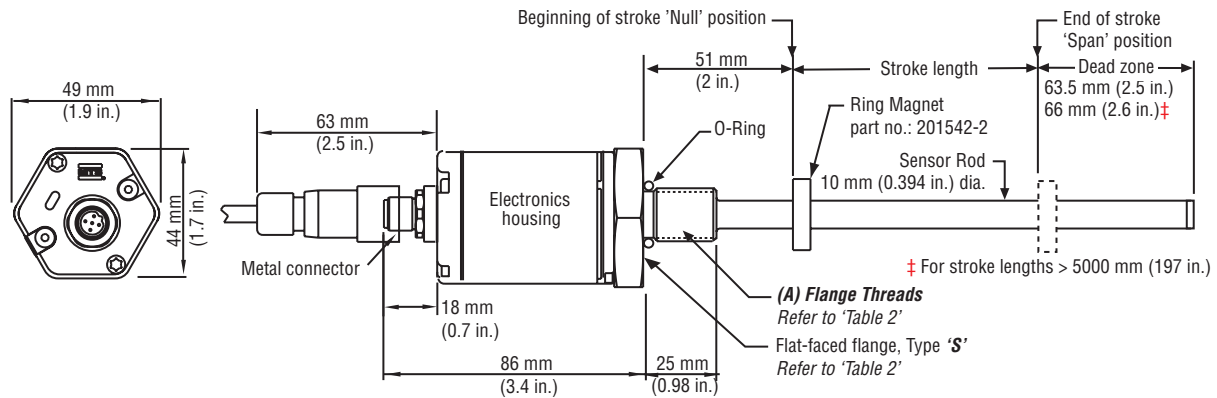

Figure 4. Model RH Rod-style sensor dimension reference (shown with **D51** integral connector options)

MODEL RH, ROD-STYLE SENSOR WITH RING MAGNET (MAGNET ORDERED SEPARATELY)

Drawing is for reference only, contact applications engineering for tolerance specific information.

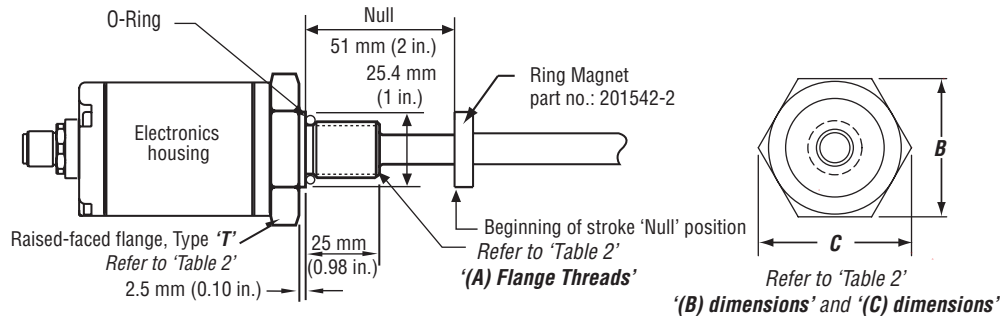

Figure 5. Model RH Rod-style sensor dimension reference (shown with **D51** integral connector option)

Housing style Flange type	Description	(A) Flange threads	(B) Dimensions	(C) Dimensions
T	US customary threads with raised-face flange	3/4" - 16 UNF-3A	1.75 in.	2 in.
S	US customary threads with flat-faced flange	3/4" - 16 UNF-3A	1.75 in.	2 in.
M	Metric threads with flat-faced flange	M18 x 1.5	46 mm	53 mm



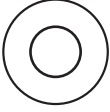

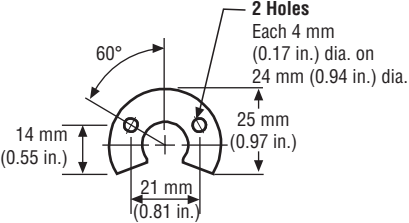

Table 2. Model RH Rod-style sensor housing style and flange type references

Standard magnet selections (Model RH)

Magnets must be ordered separately with Model RH position sensors. The standard ring magnet (part number 201542-2) is suitable for most applications.

POSITION MAGNET SELECTIONS (Magnet must be ordered separately)

(Drawing dimensions are for reference only)

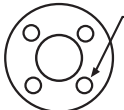
	Magnet dimensions	Description	Part number
	 <p>4 Holes Each 4.3 mm (0.17 in.) dia. 90° apart on 24 mm (0.94 in.) dia.</p>	Standard ring magnet I.D.: 13.5 mm (0.53 in.) O.D.: 33 mm (1.3 in.) Thickness: 8 mm (0.3 in.) Operating temperature: - 40 °C to 100 °C	201542-2
		Ring magnet I.D.: 13.5 mm (0.53 in.) O.D.: 25.4 mm (1 in.) Thickness: 8 mm (0.3 in.) Operating temperature: - 40 °C to 100 °C	400533
	 <p>2 Holes Each 4 mm (0.17 in.) dia. on 24 mm (0.94 in.) dia. 60° 14 mm (0.55 in.) 25 mm (0.97 in.) 21 mm (0.81 in.)</p>	Open-ring magnet, Style M I.D.: 13.5 mm (0.53 in.) O.D.: 33 mm (1.3 in.) Thickness: 8 mm (0.3 in.) Operating temperature: - 40 °C to 100 °C	251416-2
	 <p>4 Holes Each 4.3 mm (0.17 in.) dia. 90° apart on 24 mm (0.94 in.) dia.</p>	Magnet spacer (Non-ferrous, use with ring magnet) Order number: 201542-2 I.D.: 14 mm (0.56 in.) O.D.: 32 mm (1.25 in.) Thickness: 3.2 mm (0.125 in.)	400633

MAGNET FLOAT SELECTION

(Drawing dimensions are for reference only)

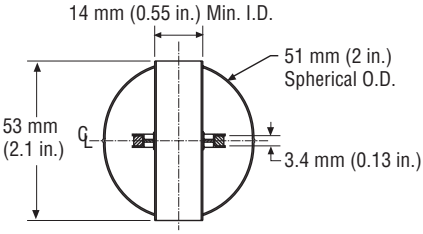
	 <p>14 mm (0.55 in.) Min. I.D. 51 mm (2 in.) Spherical O.D. 53 mm (2.1 in.) 3.4 mm (0.13 in.)</p>	Magnet float (Level sensing applications) Specific gravity: 0.70 maximum Pressure: 870 psi maximum <i>(This float is used with the Model RH Rod-style sensors for hydraulic fluid or fresh water applications only)</i>	251447
---	--	--	--------

Model RH Rod-Style sensor mounting

The position magnet requires minimum distances away from ferrous metals to allow proper sensor output. The minimum distance from the front of the magnet to the cylinder end cap is 15 mm (0.6 in.).

The minimum distance from the back of the magnet to the piston head is 3.2 mm (0.125 in.). The non-ferrous spacer (part number 400633) provides this minimum distance when used along with the standard ring magnet (part no.: 201542-2)

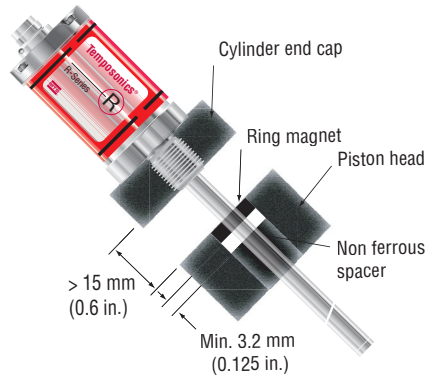

Figure 6. Model RH rod-style mounting

Cylinder installation

When used for direct-stroke measurement in fluid cylinders, the sensor's high pressure, stainless steel rod installs into a bore in the piston head/rod assembly as illustrated. This method guarantees a long-life and trouble-free operation.

The sensor cartridge can be removed from the flange and rod housing while still installed in the cylinder. This procedure allows quick and easy sensor cartridge replacement, without the loss of hydraulic pressure.

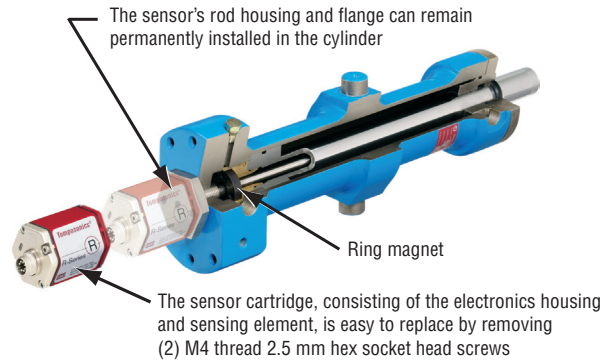

Figure 7. Fluid cylinder installation

Connections and wiring

CABLE CONNECTOR (FIELD INSTALLED FEMALE MICRO DEVICENET)



Male, 5-pin (DeviceNet micro connector) pin-out as viewed from the end of the sensor

Pin number	Function / DeviceNet outputs
1	Shield
2	+24 Vdc (+20% / -15%)
3	DC ground (for supply)
4	CAN (+)
5	CAN (-)

CABLE CONNECTOR OPTIONS (FIELD INSTALLABLE) 5-PIN DIN (D51) MALE (Drawing dimensions are for reference only)
 Appropriate grounding of cable shield is required at the controller end. Molded extension cables are available from third-party vendors.

Connector	Connector dimensions	Description	Part number
		Female Cable Connector, Straight Exit (D51) (Field installable) 5-Pin micro DeviceNet connector mates with male (D51) connection type	370375
		Female Cable Connector, 90° exit, (D51) (Field installable) 5-Pin micro DeviceNet connector mates with male (D51) connection type	370376



Document Part Number: 550651, Revision F 02-10

MTS and Temposonics are registered trademarks of MTS Systems Corporation.
All other trademarks are the property of their respective owners.
All Temposonics sensors are covered by US patent number 5,545,984. Additional patents are pending.
Printed in USA. Copyright © 2010 MTS Systems Corporation. All Rights Reserved in all media.



Sold & Serviced By:



Toll Free Phone (877) SERV098

Toll Free Fax (877) SERV099

www.electromate.com

sales@electromate.com