

Temposonics®

Magnetostrictive, Absolute, Non-contact
Linear-Position Sensors

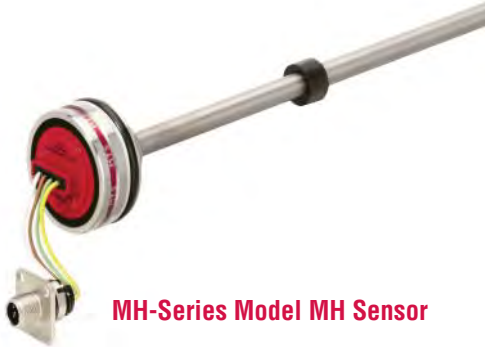

MH-Series Mobile Hydraulic in-Cylinder Sensor Model MH PWM Output Data Sheet



MH-Series Model MH Sensor



Cylinder Application Example

FEATURES

- Linear, Absolute Measurement in Hydraulic Cylinders
- Non-Contact Sensing Technology
- Superior Accuracy, $< \pm 0.04\%$ F.S.
- Hysteresis $< \pm 0.1$ mm
- Repeatability, $< \pm 0.005\%$ F.S.
- Compact Design for Embedded Cylinder Applications
- PWM Output:
 - Selectable frequency: 50 to 500 Hz
 - Scaling: 5% to 95%, 25% to 75%
- Stroke length: 50 mm (2 in.) to 2500 mm (98 in.)
- Voltage input: 12/24 Vdc
- Shock Rating: 100 g (single hit) / IEC 68-2-27
- Vibration Rating 25 g / 10-2000 Hz/IEC 68-2-6
- 200 V/m EMI Immunity

BENEFITS

- Rugged Mobile Sensor
- Direct PWM Output (Fully reversible)

APPLICATIONS

- Continuous Operation In Harsh Mobile Conditions
- High Pressure Conditions
- For Welded and Tie-rod Cylinder Applications

TYPICAL INDUSTRIES

- Construction
- Agriculture
- Off-highway Machinery

Product overview

The MH-Series Model MH sensor is designed with the “mobile” world in mind. The Model MH sensor is validated in the field by customers worldwide. Performance is second-to-none with high EMI resistance of 200 V/m. Ruggedness is “designed in”; 100 g shock and 25 g vibration rating. The model MH PWM sensor can be fully sealed and embedded in a cylinder to ensure a long operating life. Direct connection to the Temposonics® M12x1 connector system and other proven mobile connectors are available.

Sold & Serviced By:



Toll Free Phone (877) SERV098
Toll Free Fax (877) SERV099
www.electromate.com
sales@electromate.com

Product Specifications and Output

Product specifications

Parameters	Specifications	Parameters	Specifications
OUTPUT		ENVIRONMENTAL	
Measured variable:	Linear Position measurement	Operating conditions:	Operating: -40 °C (-40 °F) to +105 °C (221 °F) Storage: -30 °C (-22 °F) to +105 °C (221 °F) 90% relative humidity, no condensation
Output:	Direct PWM: Displacement Scaling: 5% to 95%, 10% to 90%, 15% to 85%, 20% to 80%, 25% to 75% Frequency (Hz): 50, 60, 100, 200, 300, 400 and 500 Consistent: $\leq \pm 0.1$ mm Signal output frequency: PWM adjustable 1 ms to 65 ms	EMC test:	200 V/m: ISO 11452-5 ISO 14982 - Agriculture and forest machinery
Stroke length:	50 mm to 2500 mm (2 in. to 98 in.) Measured in 5 mm (0.20 in.) increments	Shock rating:	100 g (single hit)/IEC standard 68-2-27 (survivability) 25 g / 10 to 2000 Hz /IEC standard 68-2-6
Linearity uncorrected:	50 to 2500 mm $\leq \pm 0.1$ mm 255 to 2000 mm $< \pm 0.04\%$ full stroke (minimum ± 0.100 mm 0.003 in.) $< \pm 0.08\%$ full stroke (for short damping zone) 500 mm $\leq \pm 0.2$ mm 750 mm $\leq \pm 0.3$ mm 1250 mm $\leq \pm 0.5$ mm 2005 to 2500 mm $\leq \pm 0.8$ mm	Vibration rating:	Sensor rod, 10 mm (0.39 in.): 25 g Sensor rod, 7 mm (0.27 in.): 15 g
Repeatability:	$< \pm 0.005\%$ of full stroke	WIRING	
Hysteresis:	± 0.1 mm (0.003 in.)	Connection type:	One 4-wire with the M12 x 1 connector and flange (provides IP69K environmental protection when installed in a cylinder).
Cycle time:	2 ms	ROD STYLE SENSOR (Model MH)	
Setpoint tolerance:	± 0.2 mm (0.007 in.)	Material:	Sensor rod: Stainless steel 1.4306 / AISI 304L Housing: Stainless steel 1.4305 / AISI 303 Mechanical assembly: Flange housing 48 mm (1.89 in.) dia., O-ring 40.87 x 3.53 mm NBR 80, backup ring 42.6 x 48 x 1.4 PTFE
Operating voltage:	12/24 Vdc (8-32 Vdc)	Sealing:	IP67 (IP69k when installed inside a cylinder with M12 x 1 in. connection type)
Power drain:	1 W	Pressure rating:	Sensor rod, 10 mm (0.39 in.): Operating, 350 bar (5076 psi) Peak, 530 bar (7687 psi) Sensor rod, 7 mm (0.27 in.): Operating, 300 bar (4350 psi) Peak, 400 bar (5800 psi)
ELECTRONICS		Magnet type:	Ring magnet (See standard magnet selections)
Electrical isolation:	500 Vdc (DC ground to machine ground)		
Polarity protection:	Up to -36 Vdc		
Overvoltage protection:	Up to 36 Vdc		

Output options

The MH-Series Model MH position PWM sensor provides consistent resolution with a adjustable signal output frequency of 1 to 65 ms.

Sold & Serviced By:



Toll Free Phone (877) SERV098
Toll Free Fax (877) SERV099
www.electromate.com
sales@electromate.com

Model MH sensor dimension references

Model MH, rod-style Sensor Drawing is for reference only, contact applications engineering for tolerance specific information.

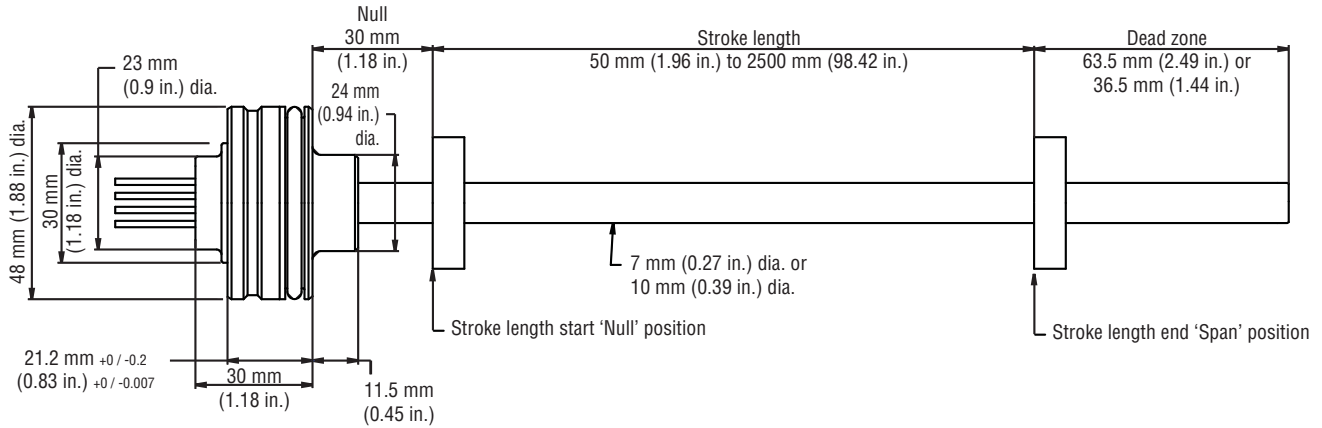

Figure 1. MH-Series Model MH rod-style sensor dimension reference

Standard magnet selections (Model MH)

SELECTION OF POSITION MAGNETS (MAGNET AND MAGNET SPACER MUST BE ORDERED SEPARATELY)

A choice of three magnets are available with the Model MH rod-style sensor. Magnets must be ordered separately with Model MH position sensors. The standard ring magnet (part number 201542-2) is suitable for most applications.

STANDARD RING MAGNET Part number 201542-2



Material: Ferrite PA
I.D.: 13.5 mm (0.53 in.)
O.D.: 33 mm (1.3 in.)
Thickness: 8 mm (0.3 in.)
Operating temperature:
 - 40 °C (-40 °F) to
 - 105 °C to (221 °F)

MAGNET SPACER Part number 400633 (used with magnet part no.: 201542-2)



Material: Non-ferrous
Used with ring magnet (part no.: 201542-2)
I.D.: 14 mm (0.56 in.)
O.D.: 32 mm (1.25 in.)
Thickness: 3.2 mm (0.125 in.)

RING MAGNET Part number 400533



Material: Ferrite PA
I.D.: 13.5 mm (0.53 in.)
O.D.: 25.4 mm (1 in.)
Thickness: 8 mm (0.3 in.)
Operating temperature:
 - 40 °C (-40 °F) to
 - 105 °C to (221 °F)

RING MAGNET Part number 401032



Material: Ferrite PA
I.D.: 13.5 mm (0.53 in.)
O.D.: 17 mm (0.68 in.)
Thickness: 8 mm (0.31 in.)
Operating temperature:
 - 40 °C (-40 °F) to
 - 105 °C to (221 °F)

Sold & Serviced By:

ELECTROMATE

Toll Free Phone (877) SERV098

Toll Free Fax (877) SERV099

www.electromate.com

sales@electromate.com

Model MH Rod-Style Sensor

Installation

Model MH sensor installation references

The robust Temposonics Model MH sensor's new stainless-steel position sensor is designed for direct stroke measurement in mobile hydraulic cylinders. The Temposonics Model MH sensor can be installed from the head side or the rod side of the cylinder depending on the cylinder design.

Installation Notes:

1. Use a non-ferrous circlip to fix the magnet.
2. The piston rod bore is dependent on hydraulic pressure and piston velocity. Minimum drilling for a (10 mm rod) should be 13.5 mm.
3. There should be no less than 3 mm clearance between the end of the sensor rod and the bottom of the rod bore at full retraction.

Model MH, rod-style sensor mechanical installation Drawing is for reference only, contact applications engineering for tolerance specific information.

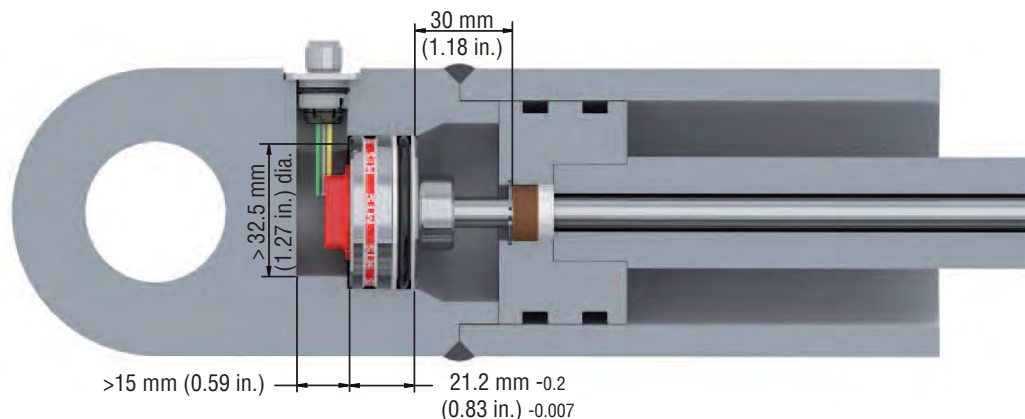

Figure 2. MH-Series Model MH rod-style sensor mechanical installation example

Model MH, rod-style sensor installation Drawings are for reference only, contact applications engineering for tolerance specific information.

Installation methods are possible in magnetic and non-magnetic applications (shown in *Figures 3 and 4*) and are entirely dependent on the cylinder design. While the most common method of installation is from the rod side of the cylinder, installation from the head side of the cylinder is also possible. In both installation methods, the sensor seals the cylinder by using an O-Ring and backup ring which is installed on the sensor housing.

Magnetic material installation reference

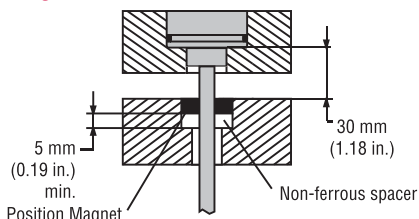

Figure 3. Model MH installation in magnetic material using a non-ferrous magnet spacer.

Non-magnetic material installation reference

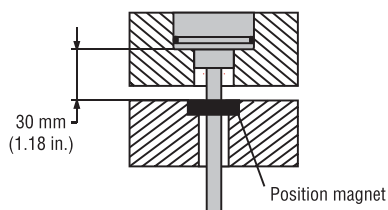
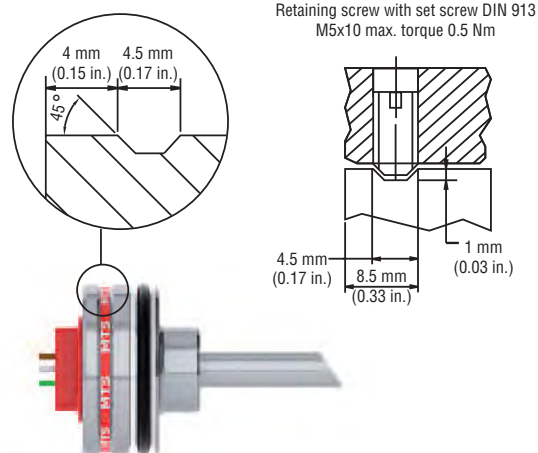

Figure 4. Model MH installation in non-magnetic material without a non-ferrous magnet spacer.

Set screw detail



Sold & Serviced By:



Toll Free Phone (877) SERV098

Toll Free Fax (877) SERV099

www.electromate.com

sales@electromate.com

Connections and wiring

CONNECTION TYPE

The Temposonics® M12 connector system (shown in *Figures 7, 8, 9 and 10*), meets the most stringent protection requirements important for the difficult environmental conditions of mobile hydraulics applications. Protection type IP69K makes the robust metal housing not only completely dust and waterproof, even the harshest cleaning measures cannot damage the sensor.

Model MH, rod-style sensor connector and pin assignments *Drawings are for reference only, contact applications engineering for tolerance specific information.*

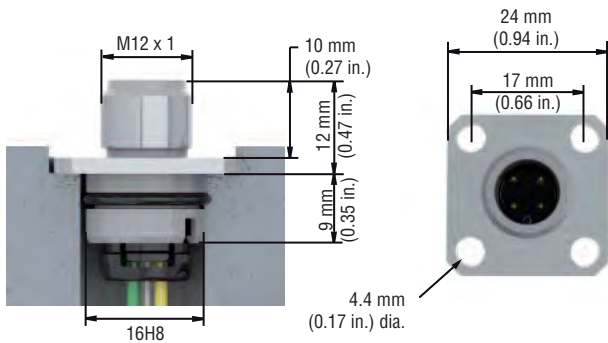

Figure 5. Model MH sensor connection dimensions

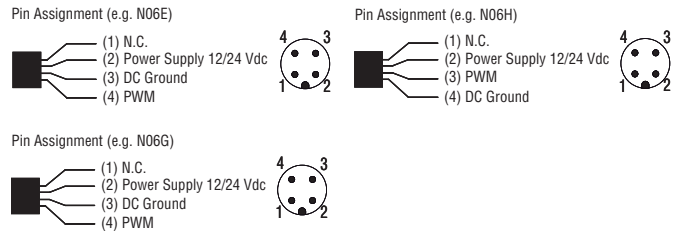

Figure 6. M12 x 1 connector system pin assignments

MOUNTING THE CONNECTOR SYSTEM TO THE CYLINDER

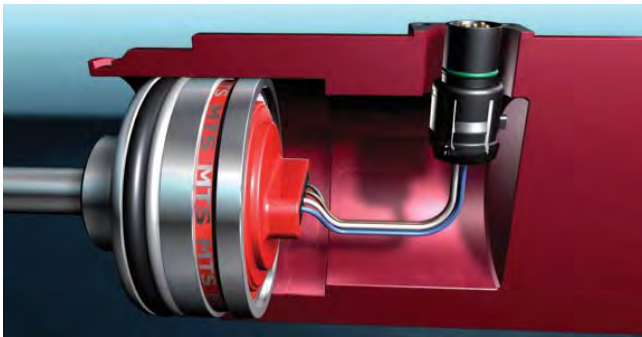

Figure 7. The MH sensor is delivered by MTS together with the new connector system: The connector insert carrier is already connected to the sensor electronics, i.e. no soldering, any color or connection mistake.



Figure 8. The connector insert is taken out of the cylinder through a bore hole. The flange housing can be snapped into position easily from outside.



Figure 9. Four standard screws must be tightened to mount the connector system on the cylinder.

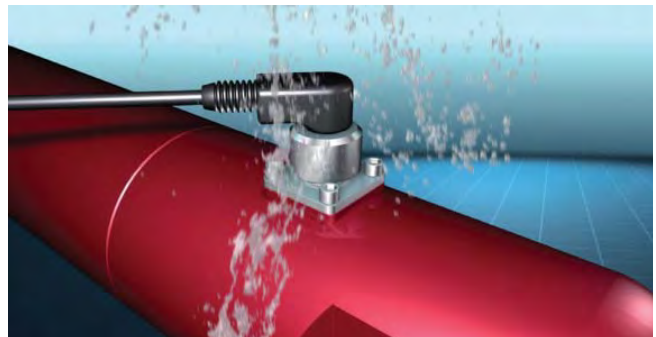

Figure 10. With a corresponding mating molded plug the connector system fulfills an ingress rating of IP69K.

Sold & Serviced By:

ELECTROMATE

Toll Free Phone (877) SERV098

Toll Free Fax (877) SERV099

www.electromate.com

sales@electromate.com

Model MH Rod-Style Sensor

Ordering Information

MH-Series Model MH ordering information

Use the table below to configure your sensor part number.

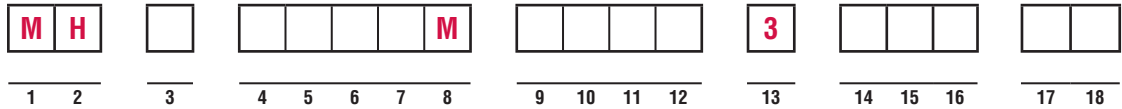

SENSOR MODEL	_____ =	M H	1-2	
MH	= Rod-style with pressure fit flange housing 48 mm (1.88 in.) dia.			
SENSOR STYLES	_____ =		3	
C	= Rod-style 10 mm (0.39 in.) dia. damping zone 63.5 mm (2.49 in.)			
D	= Rod-style 7 mm (0.27 in.) dia. damping zone 63.5 mm (2.49 in.)			
E	= Rod-style 10 mm (0.39 in.) dia. reduced damping zone 36.5 mm (1.44 in.)			
STROKE LENGTH (ORDER LENGTH)	_____ =		M	4-8
M	= Millimeters 50 to 2500 mm (in 5 mm increments)			
CONNECTION TYPE	_____ =			9-12
N _____	= Wire exit Integral 'single wires', Each conductor: 0.5 mm ² (20 AWG) Termination type:			
N __ A	= Pigtail (stripped conductors) no termination			
N __ E	= 4 single wires, M12x1 IP69K, 4 pin (pin assignment 2-3-4)			
N __ G	= 4 single wires, M12x1 IP69K, 4 pin (pin assignment 1-3-4)			
N __ H	= 4 single wires, M12x1 IP69K, 4 pin (pin assignment 1-2-3) Wire length:			
06	= 60 mm (2.36 in.) min. wire length			
25	= 250 mm (9.84 in.) max. wire length Cable exit:			
T _____	= 4 conductor / cable; integral PUR cable, pigtailed, 4 cables, shielded. Cable length (first digit x 1m., second digit x 0.1 m.)			
10	= 1.0 m length (standard all other lengths require minimum order quantities; 0.5 m min. to 9.9 max.: 0.1 m increments). Termination type:			
A	= Pigtail (stripped conductors) for wire termination, contact factory.			
INPUT VOLTAGE	_____ =	3	13	
3	= +12/24 Vdc			
OUTPUT	_____ =		14-16	
P ____	= PWM			
15 digit span range				
A	= 5 to 95%	D	= 20 to 80%	
B	= 10 to 90%	E	= 25 to 75%	
C	= 15 to 85%			
16 digit Frequency				
A	= 50 Hz	E	= 300 Hz	
B	= 60 Hz	F	= 400 Hz	
C	= 100 Hz	G	= 500 Hz	
D	= 200 Hz	X	= Not defined	
POLARITY AND FAILURE OUTPUT OPTION	_____ =			17-18
17 digit - Output polarity (Default 1)				
1	= See page 7 diagram	2	= See page 7 diagram	
3	= See page 7 diagram	4	= See page 7 diagram	
18 digit - Failure output (Default H)				
H	= Output high	L	= Output low	
M	= Square wave			

Sold & Serviced By:



Toll Free Phone (877) SERV098
Toll Free Fax (877) SERV099
www.electromate.com
sales@electromate.com

Signal diagrams

Polarity and failure output options to complete order form digits 17 and 18 are listed below.

Digit 17 - Output polarity (Default = 1)

Enter one of the options below for digit 17 for the direction and polarity of the signal:

1 = Measurement is from rising edge to falling edge, pulse width increases as magnet moves from head to tip (Default condition)

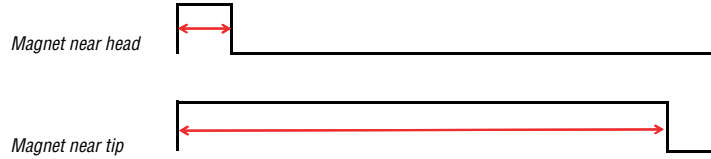

2 = Measurement is from falling edge to rising edge, pulse width decreases as magnet moves from head to tip

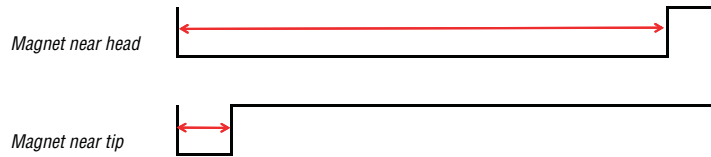

3 = Measurement is from rising edge to falling edge, pulse width decreases as magnet moves from head to tip

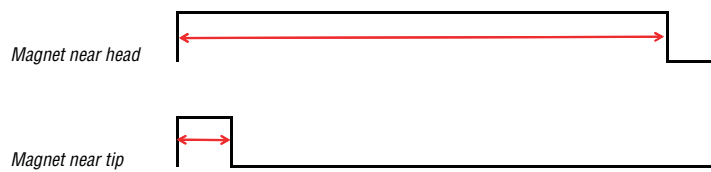

4 = Measurement is from falling edge to rising edge, pulse width increases as magnet moves from head to tip

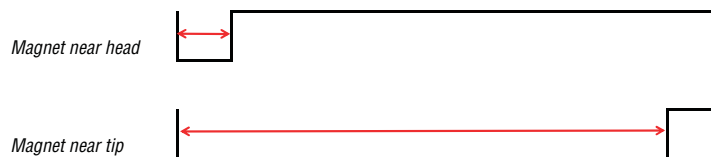

Digit 18 - Failure output (Default = H)

Enter one of the options below for digit 18 to describe the action taken if the sensor stops reading the magnet:

H = Output goes high (5 Vdc, default condition)

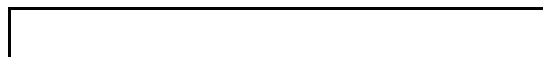

L = Output goes low (0 Vdc)



M = Output is a square wave, 50% duty cycle at 1/2 PWM frequency (Digit 15)



Sold & Serviced By:

 **ELECTROMATE**

Toll Free Phone (877) SERV098

Toll Free Fax (877) SERV099

www.electromate.com

sales@electromate.com

Magnet selections and optional Test kit

Magnets and the MH-Series Analog/PWM tester must be ordered separately. Refer to the table below for ordering information.

Magnet selections	Part no.
Ring magnet, O.D. 17.4 mm (0.68 in.)	401032
Ring magnet, O.D. 25.4 mm (0.99 in.)	400533
Ring magnet, O.D. 33 mm (1.29 in.)	201542-2
Magnet spacer (use with magnet part no.: 201542-2)	400633

Optional accessory	Part no.
MH-Series Analog/PWM Test kit	280618
MH-Series Test kit contents: <ul style="list-style-type: none"> • MH-Series Analog/PWM Tester • 12 Vdc battery charger with (adapter main plug North America, adapter main plug EU, or adapter main plug UK) • Cable with M12 x 1 connector • Cable with pigtailed wires • Carrying case • CD-Rom with user's guide 	



MH-Series Analog/PWM Tester, part no.: 280618



Document Part Number: 551119, Revision B, 02/12, 05/12, 08/12, 12/12, 06/13 (US)

MTS and Temposonics are registered trademarks of MTS Systems Corporation.

All other trademarks are the property of their respective owners.

Printed in USA. Copyright © 2013 MTS Systems Corporation. All Rights Reserved in all media.



Sold & Serviced By:



Toll Free Phone (877) SERV098

Toll Free Fax (877) SERV099

www.electromate.com

sales@electromate.com