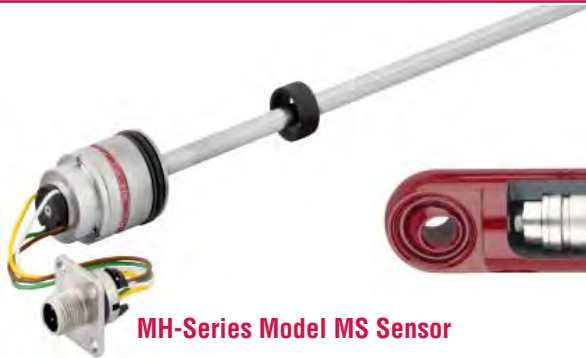


# Temposonics®

Magnetostrictive, Absolute, Non-contact  
Linear-Position Sensors



## MH-Series Mobile Hydraulic In-Cylinder Sensor Model MS Analog Output Data Sheet



MH-Series Model MS Sensor



Cylinder Application Example

### FEATURES

- Linear, Absolute Measurement in Hydraulic Cylinders
- Non-Contact Sensing Technology
- Superior Accuracy,  $< \pm 0.04\%$  F.S.
- Hysteresis  $< \pm 0.1$  mm
- Repeatability,  $< \pm 0.005\%$  F.S.
- Compact Design for Embedded Cylinder Applications
- Direct Analog Displacement Output: Current and Voltage  
0.25 to 4.75 Vdc, 4 to 20 mA
- Stroke length: 50 mm (2 in.) to 2000 mm (79 in.)
- Voltage input: 12/24 Vdc
- Shock Rating: 100 g (single hit) / IEC 68-2-27
- Vibration Rating 15 g / 10-2000 Hz/IEC 68-2-6
- 100 V/m EMI Immunity

### BENEFITS

- Rugged Mobile Sensor
- Direct Analog Output (Fully reversible)

### APPLICATIONS

- Continuous Operation In Harsh Mobile Conditions
- High Pressure Conditions
- For Welded and Tie-rod Cylinder Applications

### TYPICAL INDUSTRIES

- Construction
- Agriculture
- Off-highway Machinery

### Product overview

MTS MH series sensors are designed specifically for mobile hydraulic applications. The Model MS sensor is validated in the field by customers worldwide. Performance is second-to-none with high EMI resistance of 100 V/m. Ruggedness is “designed in”; 100 g shock and 15 g vibration rating. The model MS analog sensor can be fully sealed and embedded in a cylinder to ensure a long operating life. Direct connection to the Temposonics® M12x1 connector system and other proven mobile connectors are available.

Sold & Serviced By:

ELECTROMATE

Toll Free Phone (877) SERV098

Toll Free Fax (877) SERV099

[www.electromate.com](http://www.electromate.com)

[sales@electromate.com](mailto:sales@electromate.com)

## Product Overview and Specifications

### Output Options

### Product specifications

Parameters	Specifications
<b>OUTPUT</b>	
<b>Measured variable:</b>	Linear Position measurement
<b>Outputs:</b>	Direct Analog:  ‡ Voltage: 0.25 to 4.75 Vdc , 0.5 to 4.5 Vdc 4.75 to 0.25 Vdc , 4.5 to 0.5 Vdc ‡ Current: 4 to 20 mA , 20 to 4 mA
<b>Resolution:</b>	<b>Range:</b> <b>Resolution:</b> 50 to 500 mm                      ± 0.10 mm 505 to 2000 mm 750 mm                              ± 0.18 mm 1,000 mm                           ± 0.24 mm 1,250 mm                           ± 0.30 mm 1,750 mm                           ± 0.42 mm
<b>Stroke length:</b>	50 mm to 2000 mm (2 in. to 79 in.) Measured in 5 mm (0.20 in.) increments
<b>Linearity uncorrected:</b>	< ± 0.04% full stroke (minimum ± 0.100 mm 0.003 in.) < ± 0.08% full stroke (for short damping zone)
<b>Repeatability:</b>	< ± 0.005% of full stroke
<b>Hysteresis:</b>	± 0.1 mm (0.003 in.)
<b>Operating voltage:</b>	12/24 Vdc (8-32 Vdc)
<b>Power consumption:</b>	1 W
<b>ELECTRONICS</b>	
<b>Electrical isolation:</b>	500 Vdc (DC ground to machine ground)
<b>Polarity protection:</b>	Up to -36 Vdc
<b>Overvoltage protection:</b>	Up to 36 Vdc

Parameters	Specifications
<b>ENVIRONMENTAL</b>	
<b>Operating conditions:</b>	<b>Operating:</b> -40 °C (-40 °F) to +105 °C (221 °F) <b>Storage:</b> -30 °C (-22 °F) to +105 °C (221 °F) 90% relative humidity, no condensation
<b>EMC test:</b>	<b>100 V/m:</b> ISO 11452-5 (transient emissions stripline) 90% rel. humidity
<b>Shock rating:</b>	100 g (single hit)/IEC standard 68-2-27 (survivability)
<b>Vibration rating:</b>	<b>Sensor rod, 7 mm (0.27 in.):</b> 15 g / 10 to 2000 Hz /IEC standard 68-2-6
<b>WIRING</b>	
<b>Connection type:</b>	One 4-wire with the M12 x 1 connector and flange (provides IP69K environmental protection when installed in a cylinder).
<b>ROD STYLE SENSOR (Model MS)</b>	
<b>Material:</b>	<b>Sensor rod:</b> Stainless steel 1.4306 / AISI 304L <b>Housing:</b> Stainless steel 1.4305 / AISI 303 <b>Mechanical assembly:</b> Flange housing 28 mm (1.1 in.) dia., O-ring 23.47 x2.62 mm NBR, backup ring 28mm x 2 mm x 1.4 mm Parbak
<b>Sealing:</b>	IP67 (IP69k when installed inside a cylinder with M12 x 1 in. connection type)
<b>Pressure rating:</b>	<b>Sensor rod, 7 mm (0.27 in.):</b> Operating, 300 bar (4350 psi) Peak, 400 bar (5800 psi)
<b>Magnet type:</b>	Ring magnet (see standard magnet selections)
‡ Output range is factory programmable through entire stroke and is fully reversible.	

### Output options

The MH-Series Model MS position analog sensor provides direct analog outputs:

- Voltage; 0.25 to 4.75 Vdc, 0.5 to 4.50 Vdc (reverse acting: 4.75 to 0.25 Vdc, 4.5 to 0.5 Vdc)
- Current; 4 to 20 mA (reverse acting: 20 to 4 mA)

Sold & Serviced By:

 **ELECTROMATE**

Toll Free Phone (877) SERV098

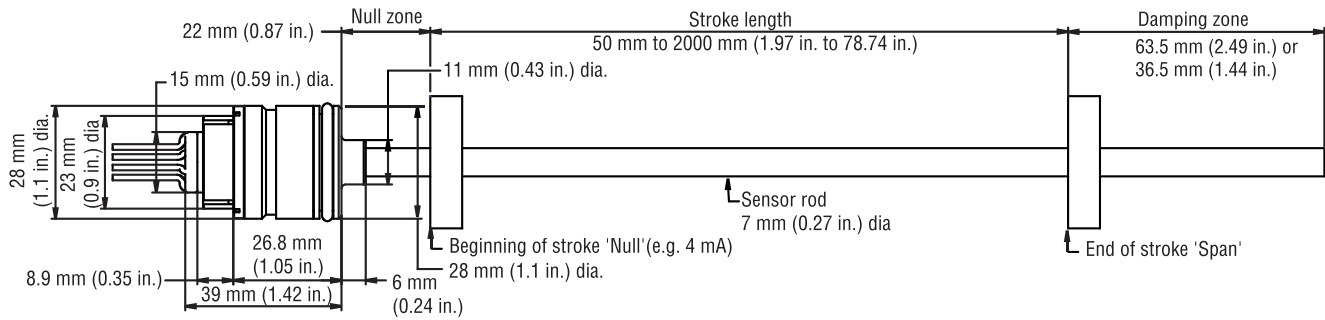
Toll Free Fax (877) SERV099

[www.electromate.com](http://www.electromate.com)

[sales@electromate.com](mailto:sales@electromate.com)

## Model MS sensor dimension references

**Model MS, rod-style Sensor** Drawing is for reference only, contact applications engineering for tolerance specific information.



**Figure 1.** MH-Series Model MS rod-style sensor dimension reference

## Standard magnet selections (Model MS)

### SELECTION OF POSITION MAGNETS (MAGNET AND MAGNET SPACER MUST BE ORDERED SEPARATELY)

A choice of three magnets are available with the Model MS rod-style sensor. Magnets must be ordered separately with Model MS position sensors. The standard ring magnet (part number 201542-2) is suitable for most applications.

#### STANDARD RING MAGNET Part number 201542-2



**Material:** Ferrite PA  
**I.D.:** 13.5 mm (0.53 in.)  
**O.D.:** 33 mm (1.3 in.)  
**Thickness:** 8 mm (0.3 in.)  
**Operating temperature:**  
- 40 °C (-40 °F) to  
- 105 °C to (221 °F)

#### MAGNET SPACER Part number 400633 (Used with magnet part no.: 201542-2)



**Material:** Non-ferrous  
*used with ring magnet (part no.: 201542-2)*  
**I.D.:** 14 mm (0.56 in.)  
**O.D.:** 32 mm (1.25 in.)  
**Thickness:** 3.2 mm (0.125 in.)

#### RING MAGNET Part number 400533



**Material:** Ferrite PA  
**I.D.:** 13.5 mm (0.53 in.)  
**O.D.:** 25.4 mm (1 in.)  
**Thickness:** 8 mm (0.3 in.)  
**Operating temperature:**  
- 40 °C (-40 °F) to  
- 105 °C to (221 °F)

#### RING MAGNET Part number 401032



**Material:** Ferrite PA  
**I.D.:** 13.5 mm (0.53 in.)  
**O.D.:** 17 mm (0.68 in.)  
**Thickness:** 8 mm (0.31 in.)  
**Operating temperature:**  
- 40 °C (-40 °F) to  
- 105 °C to (221 °F)

## Model MS Rod-Style Sensor

### Installation

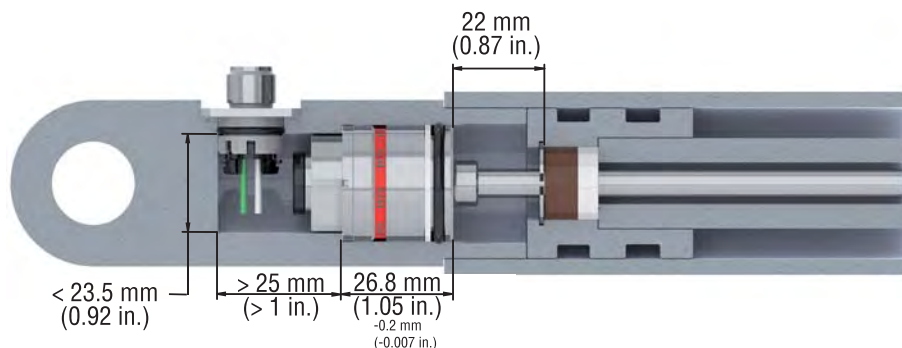
#### Model MS sensor installation references

The robust Temposonics Model MS sensor's new stainless-steel position sensor is designed for direct stroke measurement in mobile hydraulic cylinders. The Temposonics Model MS sensor can be installed from the head side or the rod side of the cylinder depending on the cylinder design.

#### Installation Notes:

1. Use a non-ferrous circlip to fix the magnet.
2. The piston rod bore is dependent on hydraulic pressure and piston velocity. Minimum drilling for a (7 mm rod) should be 10 mm.
3. There should be no less than 3 mm clearance between the end of the sensor rod and the bottom of the rod bore at full retraction.

**Model MS, rod-style sensor mechanical installation** Drawing is for reference only, contact applications engineering for tolerance specific information.

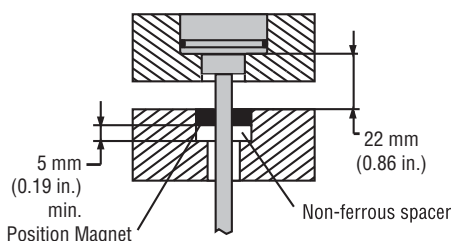


**Figure 2.** MH-Series Model MS rod-style sensor mechanical installation example

**Model MS, rod-style sensor installation** Drawings are for reference only, contact applications engineering for tolerance specific information.

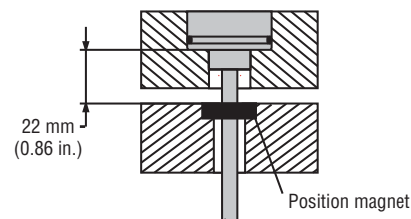
Installation methods are possible in magnetic and non-magnetic applications (shown in Figures 3 and 4) and are entirely dependent on the cylinder design. While the most common method of installation is from the rod side of the cylinder, installation from the head side of the cylinder is also possible. In both installation methods, the sensor seals the cylinder by using an O-Ring and backup ring which is installed on the sensor housing.

#### Magnetic material installation reference



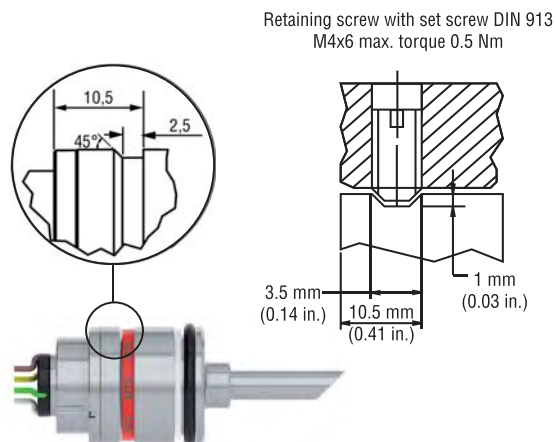
**Figure 3.** Model MS installation in magnetic material using a non-ferrous magnet spacer.

#### Non-magnetic material installation reference



**Figure 4.** Model MS installation in non-magnetic material (without a non-ferrous magnet spacer).

#### Set screw detail

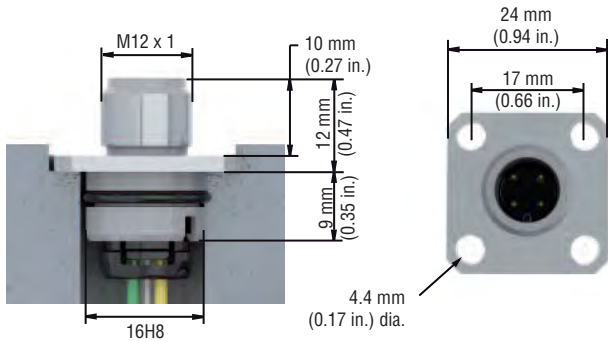


## Connections and wiring

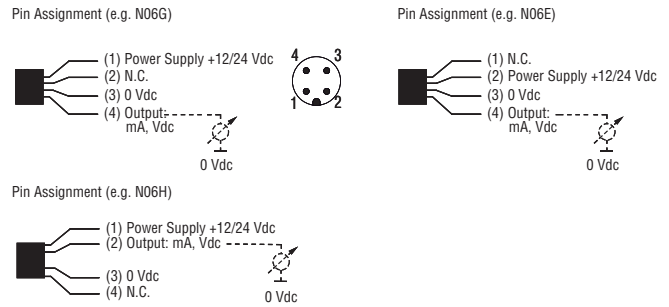
### CONNECTION TYPE

The Temposonics® M12 connector system (shown in *Figures 7, 8, 9 and 10*), meets the most stringent protection requirements important for the difficult environmental conditions of mobile hydraulics applications. Protection type IP69K makes the robust metal housing not only completely dust and waterproof, even the harshest cleaning measures cannot damage the sensor.

**Model MS, rod-style sensor connector and pin assignments** *Drawings are for reference only, contact applications engineering for tolerance specific information.*

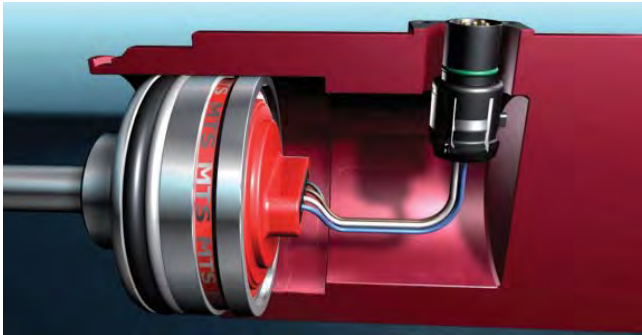


**Figure 5.** Model MS sensor connection dimensions



**Figure 6.** M12 x 1 connector system pin assignments

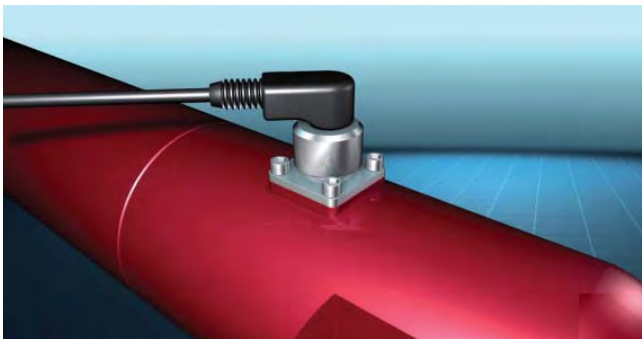
### MOUNTING THE CONNECTOR SYSTEM TO THE CYLINDER



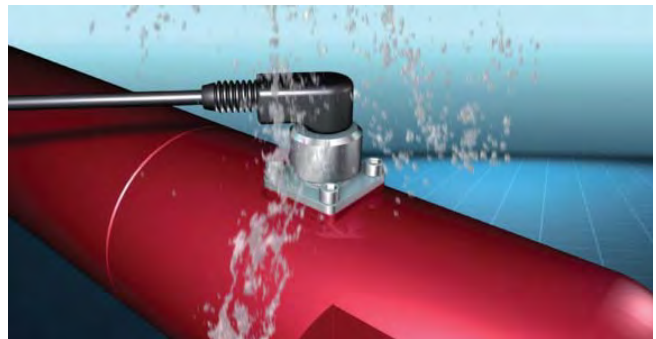
**Figure 7.** The MS sensor is delivered by MTS together with the new connector system: The connector insert carrier is already connected to the sensor electronics, i.e. no soldering, any color or connection mistake.



**Figure 8.** The connector insert is taken out of the cylinder through a bore hole. The flange housing can be snapped into position easily from outside.



**Figure 9.** Four standard screws must be tightened to mount the connector system on the cylinder.



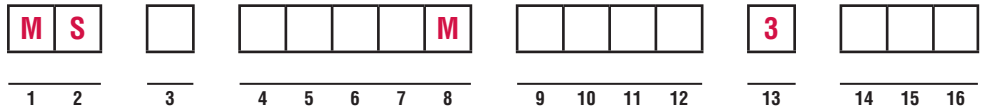
**Figure 10.** With a corresponding mating molded plug the connector system fulfills a ingress rating of IP69K.

# Model MS Rod-Style Sensor

## Ordering Information

### MH-Series Model MS ordering information

Use the table below to configure your sensor part number.



**SENSOR MODEL** \_\_\_\_\_ = **MS**  
**MS** = Rod-style with pressure fit flange housing 28 mm (1.10 in.) dia.

**SENSOR STYLES** \_\_\_\_\_ = **3**  
**D** = Rod-style 7 mm (0.27 in.) dia. (Damping zone 63.5 mm (2.49 in.))  
**F** = Rod-style 7 mm (0.27 in.) dia. (Damping zone 36.5 mm (1.44 in.))

**STROKE LENGTH (ORDER LENGTH)** \_\_\_\_\_ = **M** **4-8**  
**M** = Millimeters  
*50 to 2000 mm (1.97 to 78.74 in.) (in 5 mm (0.2 in.) increments)*

**CONNECTION TYPE** \_\_\_\_\_ = \_\_\_\_\_ **9-12**

**N** \_\_\_\_\_ = **Wire exit**  
 Integral 'single wires', Each conductor: 0.5 mm<sup>2</sup> (20 AWG)

**Termination type:**

- N** **A** = Pigtail (stripped conductors) no termination
- N** **E** = 4 single wires, M12x1 IP69K, 4 pin (pin assignment 2-3-4)
- N** **G** = 4 single wires, M12x1 IP69K, 4 pin (pin assignment 1-3-4)
- N** **H** = 4 single wires, M12x1 IP69K, 4 pin (pin assignment 1-2-3)

**Wire length:**

- 06** = 60 mm (2.36 in.) min. wire length
- 25** = 250 mm (9.84 in.) max. wire length

**Cable exit:**

**T** \_\_\_\_\_ 4 conductor / cable; integral PUR cable, pigtailed, 4 cables, shielded. Cable length ( first digit x 1 m., second digit x 0.1 m.)  
**10** = 1.0 m length (standard all other lengths require minimum order quantities; 0.5 m min. to 9.9 max.: 0.1 m increments).

**Termination type:**

- A** = Pigtail (stripped conductors) for wire termination, contact factory.

**INPUT VOLTAGE** \_\_\_\_\_ = **3**  
**3** = +12/24 Vdc

**OUTPUT** \_\_\_\_\_ = \_\_\_\_\_ **14-16**

**Voltage:**

- V11** = 0.25 to 4.75 Vdc
- V12** = 0.5 to 4.5 Vdc
- V13** = 4.75 to 0.25 Vdc
- V14** = 4.5 to 0.5 Vdc

**Current:**

- A01** = 4 to 20 mA
- A04** = 20 to 4 mA

## Magnet selections and optional Test kit

Magnets and the MH-Series Analog/PWM tester must be ordered separately. Refer to the table below for ordering information.

Magnet selections	Part no.
Ring magnet, O.D. 17.4 mm (0.68 in.)	401032
Ring magnet, O.D. 25.4 mm (0.99 in.)	400533
Ring magnet, O.D. 33 mm (1.29 in.)	201542-2
Magnet spacer	400633

Optional accessory	Part no.
MH-Series Analog/PWM Tester	280618
<b>The MH-Series Tester includes:</b>	
<ul style="list-style-type: none"><li>• MH-Series analog / PWM Tester</li><li>• 12 Vdc battery charger with (adapter main plug North America, adapter main plug EU or adapter main plug UK)</li><li>• Cable with M12 x 1 connector</li><li>• Cable with pigtailed wires</li><li>• Carrying case</li><li>• CD-Rom with user's guide</li></ul>	



MH-Series Analog/PWM Tester, part no.: 280618

Sold & Serviced By:

 **ELECTROMATE**

Toll Free Phone (877) SERV098

Toll Free Fax (877) SERV099

[www.electromate.com](http://www.electromate.com)

[sales@electromate.com](mailto:sales@electromate.com)