

Temposonics®

Magnetostrictive, Absolute, Non-contact
Linear-Position Sensors

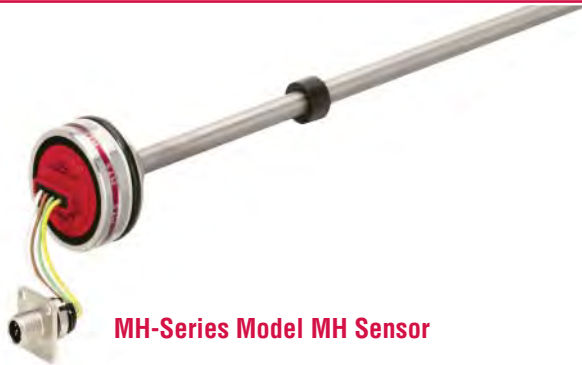

MH-Series Mobile Hydraulic in-Cylinder Sensor Model MH Analog Output Data Sheet



MH-Series Model MH Sensor



Cylinder Application Example

FEATURES

- Linear, Absolute Measurement in Hydraulic Cylinders
- Non-Contact Sensing Technology
- Superior Accuracy, $< \pm 0.04\%$ F.S.
- Hysteresis $< \pm 0.1$ mm
- Repeatability, $< \pm 0.005\%$ F.S.
- Compact Design for Embedded Cylinder Applications
- Direct Analog Output:
0.25 to 4.75 Vdc, 4 to 20 mA
- Stroke length: 50 mm (2 in.) to 2500 mm (98 in.)
- Voltage input: 12/24 Vdc
- Shock Rating: 100 g (single hit) / IEC 68-2-27
- Vibration Rating 25 g / 10-2000 Hz/IEC 68-2-6
- 200 V/m EMI Immunity

BENEFITS

- Rugged Mobile Sensor
- Direct Analog Output (Fully reversible)

APPLICATIONS

- Continuous Operation In Harsh Mobile Conditions
- High Pressure Conditions
- For Welded and Tie-rod Cylinder Applications

TYPICAL INDUSTRIES

- Construction
- Agriculture
- Off-highway Machinery

Product overview

The MH-Series Model MH sensor is designed with the “mobile” world in mind. The Model MH sensor is validated in the field by customers worldwide. Performance is second-to-none with high EMI resistance of 200 V/m. Ruggedness is “designed in”; 100 g shock and 25 g vibration rating. The model MH analog sensor can be fully sealed and embedded in a cylinder to ensure a long operating life. Direct connection to the Temposonics® M12x1 connector system and other proven mobile connectors are available.

Sold & Serviced By:



Toll Free Phone (877) SERV098
Toll Free Fax (877) SERV099
www.electromate.com
sales@electromate.com

Product Specifications and Output Options

Product specifications

Parameters	Specifications
OUTPUT	
Measured variable:	Linear Position measurement
Resolution:	Range: 50 to 500 mm 750 mm 1,000 mm 1,250 mm 1,750 mm
	Resolution: ± 0.10 mm ± 0.18 mm ± 0.24 mm ± 0.30 mm ± 0.42 mm
Outputs:	Voltage: 0.25 to 4.75 Vdc 0.5 to 4.5 Vdc with failure output signal Load resistance: > 10k Ω
	Current: 4 to 20 mA Load resistance: $\leq 250\Omega$ at 12/24 Vdc power supply
Stroke length:	50 mm to 2500 mm (2 in. to 98 in.) Measured in 5 mm (0.20 in.) increments
Linearity uncorrected:	< $\pm 0.04\%$ full stroke (minimum ± 0.100 mm 0.003 in.) < $\pm 0.08\%$ full stroke (for short damping zone)
Repeatability:	< $\pm 0.005\%$ of full stroke
Hysteresis:	± 0.1 mm (0.003 in.)
Outputs:	Direct Analog: \ddagger Voltage: 0.25 to 4.75 Vdc , 0.5 to 4.5 Vdc 4.75 to 0.25 Vdc , 4.5 to 0.5 Vdc \ddagger Current: 4 to 20 mA , 20 to 4 mA
Operating voltage:	12/24 Vdc (8-32 Vdc)
Power consumption:	1 W
ELECTRONICS	
Electrical isolation:	500 Vdc (DC ground to machine ground)
Polarity protection:	Up to -36 Vdc
Overvoltage protection:	Up to 36 Vdc

Parameters	Specifications
ENVIRONMENTAL	
Operating conditions:	Operating: -40 °C (-40 °F) to +105 °C (221 °F) Storage: -30 °C (-22 °F) to +105 °C (221 °F) 90% relative humidity, no condensation
EMI test:	200 V/m: ISO 11452-5 ISO 14982 - Agriculture and forest machinery
Shock rating:	100 g (single hit)/IEC standard 68-2-27 (survivability)
Vibration rating:	25 g / 10 to 2000 Hz /IEC standard 68-2-6
WIRING	
Connection type:	One 4-wire with the M12x1 connector and flange (provides IP69K environmental protection when installed in a cylinder).
ROD STYLE SENSOR (Model MH)	
material:	Sensor rod: Stainless steel 1.4306 / AISI 304L Housing: Stainless steel 1.4305 / AISI 303 Mechanical assembly: Flange housing 48 mm (1.89 in.) dia., O-ring 40.87 x 3.53 mm NBR 80, backup ring 42.6 x 48 x 1.4 PTFE
Sealing:	IP67 (IP69k when installed inside a cylinder with M12 x 1 in. connection type)
Pressure rating:	Sensor rod, 10 mm (0.39 in.): Operating, 350 bar (5076 psi) Peak, 530 bar (7687 psi) Sensor rod, 7 mm (0.27 in.): Operating, 300 bar (4350 psi) Peak, 400 bar (5800 psi)
Magnet type:	Ring magnet,
	\ddagger Output range is factory programmable through entire stroke and is fully reversible.

Output options

The MH-Series Model MH position analog sensor provides direct analog outputs:

- Voltage; 0.25 to 4.75 Vdc, 0.5 to 4.50 Vdc (reverse acting: 4.75 to 0.25 Vdc, 4.5 to 0.5 Vdc)
- Current; 4 to 20 mA (reverse acting: 20 to 4 mA)

Sold & Serviced By:



Toll Free Phone (877) SERV098
Toll Free Fax (877) SERV099
www.electromate.com
sales@electromate.com

Model MH sensor dimension references

Model MH, rod-style Sensor Drawing is for reference only, contact applications engineering for tolerance specific information.

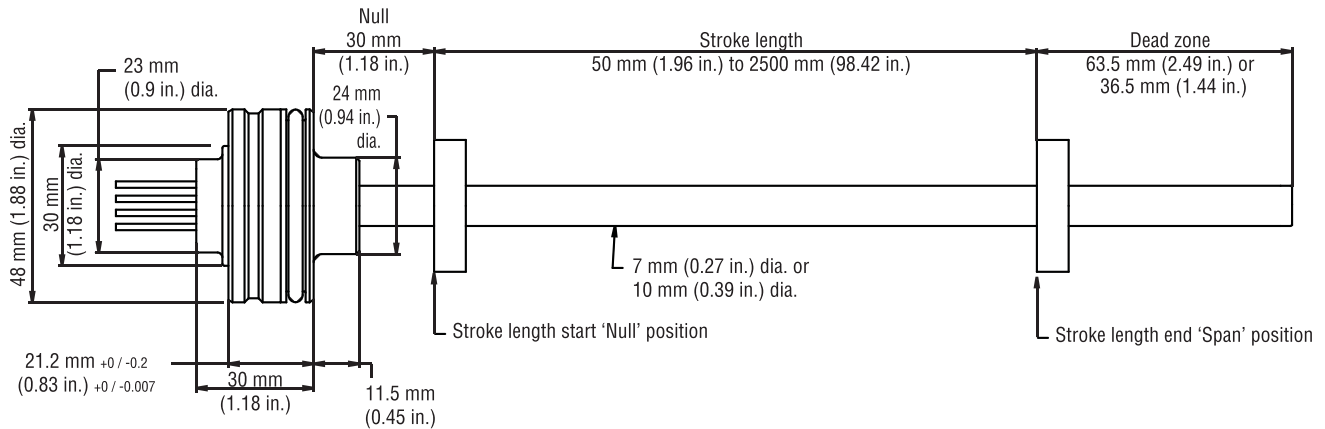

Figure 1. MH-Series Model MH rod-style sensor dimension reference

Standard magnet selections (Model MH)

SELECTION OF POSITION MAGNETS (MAGNET AND MAGNET SPACER MUST BE ORDERED SEPARATELY)

A choice of three magnets are available with the Model MH rod-style sensor. Magnets must be ordered separately with Model MH position sensors. The standard ring magnet (part number 201542-2) is suitable for most applications.

STANDARD RING MAGNET Part number 201542-2



Material: Ferrite PA
I.D.: 13.5 mm (0.53 in.)
O.D.: 33 mm (1.3 in.)
Thickness: 8 mm (0.3 in.)
Operating temperature:
- 40 °C (-40 °F) to
- 105 °C to (221 °F)

MAGNET SPACER Part number 400633 (used with magnet part no.: 201542-2)



Material: Non-ferrous, used with
ring magnet (part no.: 201542-2)
I.D.: 14 mm (0.56 in.)
O.D.: 32 mm (1.25 in.)
Thickness: 3.2 mm (0.125 in.)

RING MAGNET Part number 400533



Material: Ferrite PA
I.D.: 13.5 mm (0.53 in.)
O.D.: 25.4 mm (1 in.)
Thickness: 8 mm (0.3 in.)
Operating temperature:
- 40 °C (-40 °F) to
- 105 °C to (221 °F)

RING MAGNET Part number 401032



Material: Ferrite PA
I.D.: 13.5 mm (0.53 in.)
O.D.: 17 mm (0.68 in.)
Thickness: 8 mm (0.31 in.)
Operating temperature:
- 40 °C (-40 °F) to
- 105 °C to (221 °F)

Sold & Serviced By:

ELECTROMATE

Toll Free Phone (877) SERV098

Toll Free Fax (877) SERV099

www.electromate.com

sales@electromate.com

Model MH Rod-Style Sensor

Installation

Model MH sensor installation references

The robust Temposonics Model MH sensor's new stainless-steel position sensor is designed for direct stroke measurement in mobile hydraulic cylinders. The Temposonics Model MH sensor can be installed from the head side or the rod side of the cylinder depending on the cylinder design.

Installation Notes:

1. Use a non-ferrous circlip to fix the magnet.
2. The piston rod bore is dependent on hydraulic pressure and piston velocity. Minimum drilling for a (10 mm rod) should be 13.5 mm.
3. There should be no less than 3 mm clearance between the end of the sensor rod and the bottom of the rod bore at full retraction.

Model MH, rod-style sensor mechanical installation Drawing is for reference only, contact applications engineering for tolerance specific information.

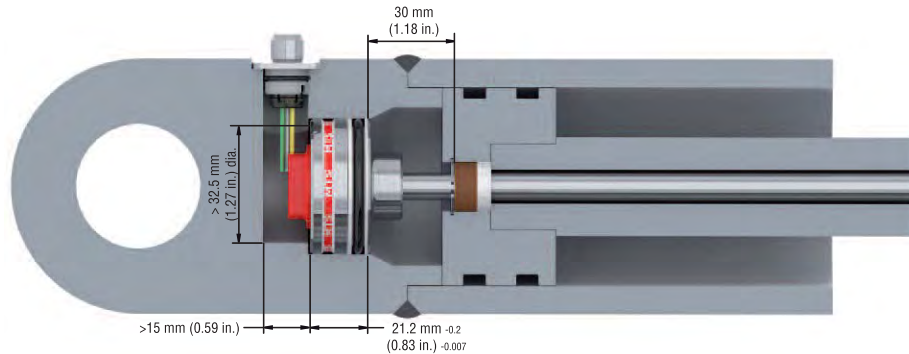

Figure 2. MH-Series Model MH rod-style sensor mechanical installation example

Model MH, rod-style sensor installation Drawings are for reference only, contact applications engineering for tolerance specific information.

Installation methods are possible in magnetic and non-magnetic applications (shown in Figures 3 and 4) and are entirely dependent on the cylinder design. While the most common method of installation is from the rod side of the cylinder, installation from the head side of the cylinder is also possible. In both installation methods, the sensor seals the cylinder by using an O-Ring and backup ring which is installed on the sensor housing.

Magnetic material installation reference

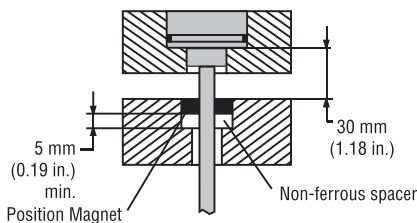

Figure 3. Model MH installation in magnetic material using a non-ferrous magnet spacer.

Non-magnetic material installation reference

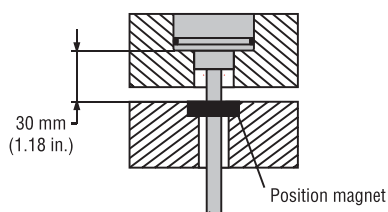
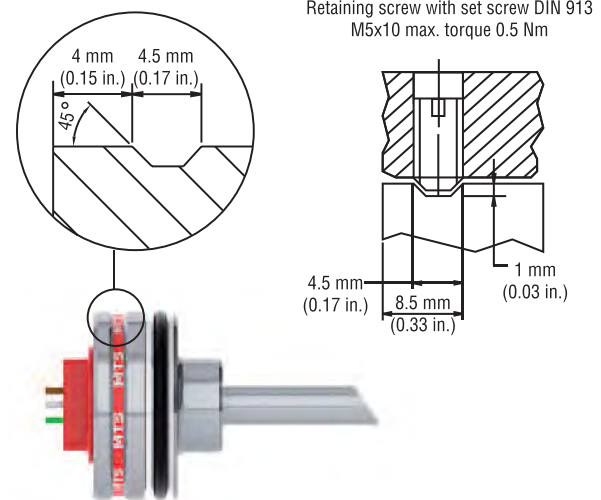

Figure 4. Model MH installation in non-magnetic material shown without magnet spacer

Set screw detail



Sold & Serviced By:

ELECTROMATE

Toll Free Phone (877) SERV098

Toll Free Fax (877) SERV099

www.electromate.com

sales@electromate.com

Connections and wiring

CONNECTION TYPE

The Temposonics® M12 connector system (shown in *Figures 7, 8, 9 and 10*), meets the most stringent protection requirements important for the difficult environmental conditions of mobile hydraulics applications. Protection type IP69K makes the robust metal housing not only completely dust and waterproof, even the harshest cleaning measures cannot damage the sensor.

Model MH, rod-style sensor connector and pin assignments *Drawings are for reference only, contact applications engineering for tolerance specific information.*

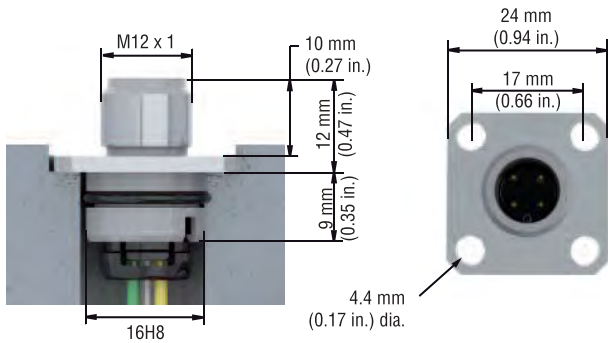

Figure 5. Model MH sensor connection dimensions

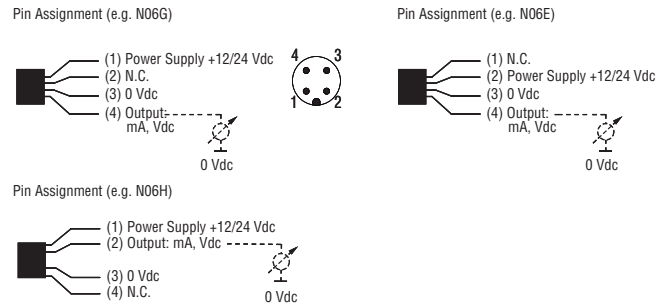

Figure 6. M12 x 1 connector system pin assignments

MOUNTING THE CONNECTOR SYSTEM TO THE CYLINDER

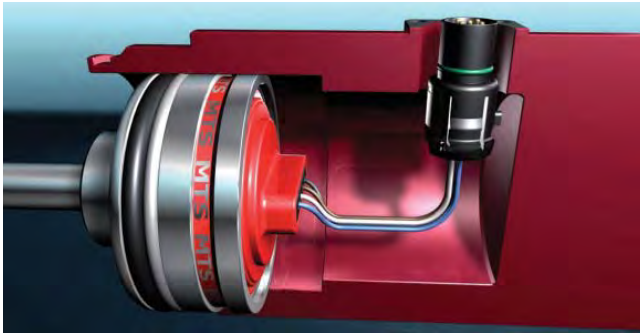

Figure 7. The MH sensor is delivered by MTS together with the new connector system: The connector insert carrier is already connected to the sensor electronics, i.e. no soldering, any color or connection mistake.



Figure 8. The connector insert is taken out of the cylinder through a bore hole. The flange housing can be snapped into position easily from outside.



Figure 9. Four standard screws must be tightened to mount the connector system on the cylinder.



Figure 10. With a corresponding mating molded plug the connector system fulfills an ingress rating of IP69K.

Model MH Rod-Style Sensor

Ordering Information

MH-Series Model MH ordering information

Use the table below to configure your sensor part number.

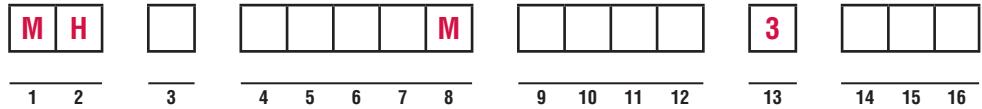

SENSOR MODEL _____ =		M H	1-2
MH = Rod-style with pressure fit flange housing 48 mm (1.88 in.) dia.			
SENSOR STYLES _____ =			3
C = Rod-style 10 mm (0.39 in.) dia. damping zone 63.5 mm (2.49 in.)	F = Rod-style 7 mm (0.27 in.) dia. reduced damping zone 36.5 mm (1.44 in.)		
D = Rod-style 7 mm (0.27 in.) dia. damping zone 63.5 mm (2.49 in.)			
E = Rod-style 10 mm (0.39 in.) dia. reduced damping zone 36.5 mm (1.44 in.)			
STROKE LENGTH (ORDER LENGTH) _____ =			4-8
----- M = Millimeters 50 to 2500 mm (in 5 mm increments)			
CONNECTION TYPE _____ =			9-12
N _____ = Wire exit Integral 'single wires', Each conductor: 0.5 mm ² (20 AWG)			
Termination type:			
N__A = Pigtail (stripped conductors) no termination			
N__E = 4 single wires, M12x1 IP69K, 4 pin (pin assignment 2-3-4)			
N__G = 4 single wires, M12x1 IP69K, 4 pin (pin assignment 1-3-4)			
N__H = 4 single wires, M12x1 IP69K, 4 pin (pin assignment 1-2-3)			
Wire length:			
06 = 60 mm (2.36 in.) min. wire length			
25 = 250 mm (9.84 in.) max. wire length			
Cable exit:			
T _____ 4 conductor / cable; integral PUR cable, pigtailed, 4 cables, shielded. Cable length (first digit x 1m., second digit x 0.1 m.)			
10 = 1.0 m length (standard all other lengths require minimum order quantities; 0.5 m min. to 9.9 max.: 0.1 m increments).			
Termination type:			
A = Pigtail (stripped conductors) for wire termination, contact factory.			
INPUT VOLTAGE _____ =		3	13
3 = 12/24 Vdc			
OUTPUT _____ =			14-16
Voltage:			
V11 = 0.25 to 4.75 Vdc			
V12 = 0.5 to 4.5 Vdc			
V13 = 4.75 to 0.25 Vdc			
V14 = 4.5 to 0.5 Vdc			
Current:			
A01 = 4 to 20 mA			
A04 = 20 to 4 mA			

Sold & Serviced By:



Toll Free Phone (877) SERV098

Toll Free Fax (877) SERV099

www.electromate.com

sales@electromate.com

Magnet selections and optional Test kit

Magnets and the MH-Series Analog/PWM tester must be ordered separately. Refer to the table below for ordering information.

Magnet selections	Part no.
Ring magnet, O.D. 17.4 mm (0.68 in.)	401032
Ring magnet, O.D. 25.4 mm (0.99 in.)	400533
Ring magnet, O.D. 33 mm (1.29 in.)	201542-2
Magnet spacer	400633

Optional accessory	Part no.
MH-Series Analog/PWM Tester	280618
The MH-Series Tester includes:	
<ul style="list-style-type: none">• MH-Series analog / PWM Tester• 12 Vdc battery charger with (adapter main plug North America, adapter main plug EU or adapter main plug UK)• Cable with M12 x 1 connector• Cable with pigtailed wires• Carrying case• CD-Rom with user's guide	



MH-Series Analog/PWM Tester, part no.: 280618

Sold & Serviced By:

 **ELECTROMATE**

Toll Free Phone (877) SERV098

Toll Free Fax (877) SERV099

www.electromate.com

sales@electromate.com