

Modular integrated Robot Joint

High torque and low cogging for excellent performance



Sold & Serviced By:

 **ELECTROMATE**

Toll Free Phone (877) SERV098

www.electromate.com

sales@electromate.com

Robot Joint Overview



High performance



Compact



Easy to use



Introduction

maxon's compact EC frameless motors combined with an EPOS4 positioning controller delivers a highly dynamic, powerful drive package with field-oriented control (FOC), high efficiency, and maintenance-free components in a high-quality industrial housing. High torque and low cogging effect provide excellent performance. Zero Backlash gearheads in combination with a double feedback system allows for excellent positioning movements. To ensure safety during operation a brake system can be added.

Design of the Robot Joint

The compact modular design of the robot joint series is optimal for performance and size. Various options are available such as a hollow shaft, torque sensor, brake and electronics.

Positioning Controller (under development)

The next generation of positioning controllers offer impressively superior dynamics and outstanding power density. The modular design opens up a wide range of opportunities regarding communication and feedback encoders. The CANopen and EtherCAT field buses, as well as the adjustable digital and analog inputs and outputs, are matched optimally to the various functions and operating modes of the CiA-402 device profile. In addition to the intuitive commissioning software, there are libraries available free of charge for integration into a wide variety of master systems. With the graphic user interface of the EPOS Studio, the configurable drive system automatically searches for ideal control parameters (auto tuning) and is ready for use at the press of a button.

Commissioning

maxon preconfigures the robot joints before shipping. Motor, encoder, and brake parameters are stored on the positioning controller at the factory. For commissioning at the customer site, maxon provides the auto tuning function via the EPOS Studio. This reduces the installation time dramatically.

Gear

The customized zero backlash gear with its high position accuracy and zero backlash can achieve high precision and optimal position control. Various gear ratios can be selected.

Brake

The drive can be combined with an optional holding brake; this increases the length of the drive. The brake is active when disconnected from power. It is a holding brake, which is not suitable for deceleration. The brake is controlled by the integrated controller.

Encoders

The Robot Joint series has two integrated encoders. The two different encoder signals can be evaluated simultaneously. This allows for dual-loop control which can be tuned automatically to compensate for mechanical backlash and elasticity.

Torque Sensor

The torque sensor can be used to measure torque at the output shaft of the robotic joint.

Robot Joint Selection

maxon Robot Joints are integrated systems and can be build according to the customer requirements. The base joints on the following pages are containing motor, gear, brake, hollow shaft and double feedback system. An optional position controller and torque sensor can be added. Detailed dimensional drawings based on the selected options are available upon request.

Sold & Serviced By:



Toll Free Phone (877) SERV098
www.electromate.com
sales@electromate.com

Product components

- maxon brushless EC frameless motors
- Customized zero backlash gear
- Double feedback system
- Brake
- Positioning Controller (under development)
- Torque sensor
- Hollow shaft

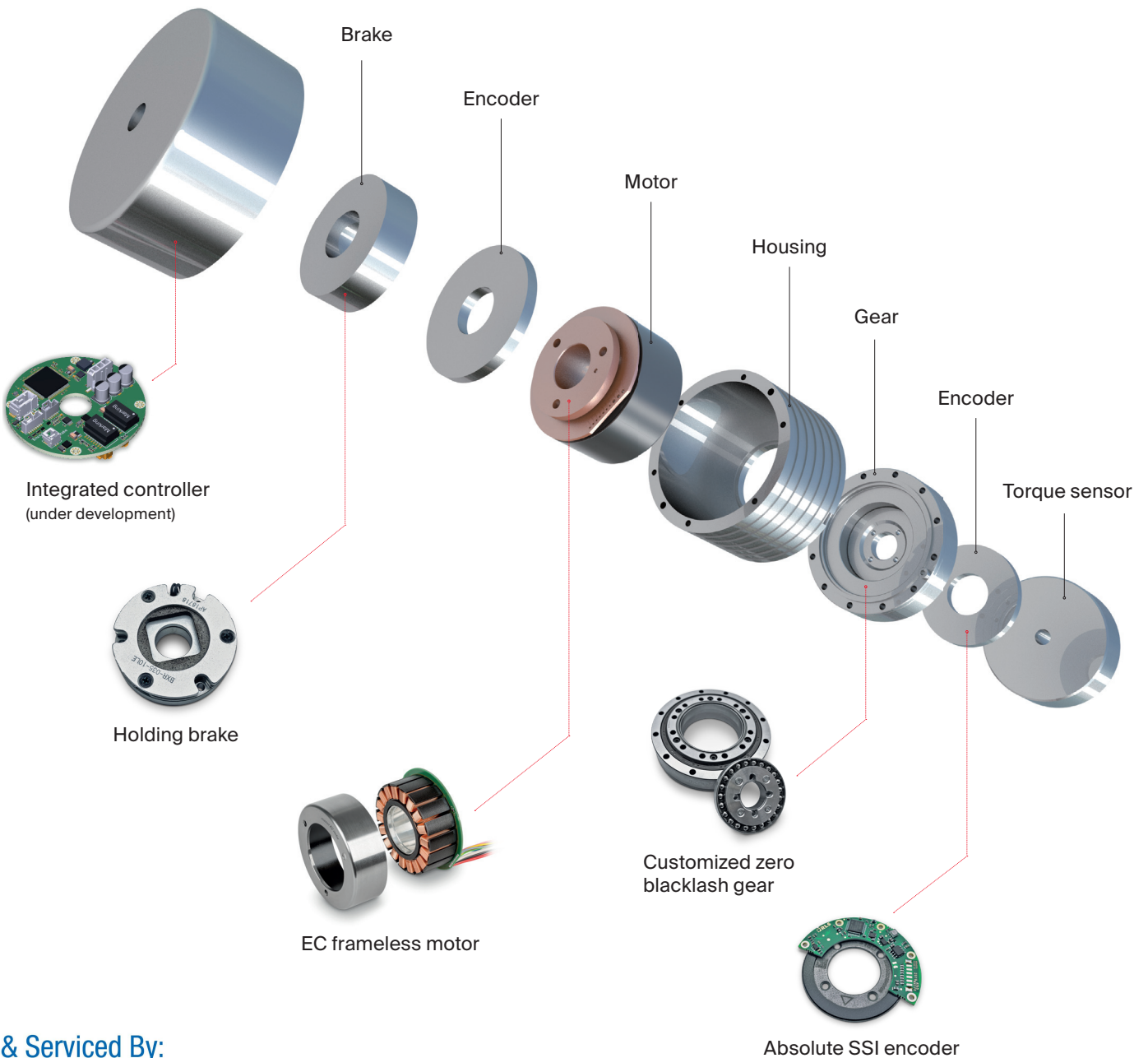

Sold & Serviced By:

 **ELECTROMATE**

Toll Free Phone (877) SERV098

www.electromate.com

sales@electromate.com

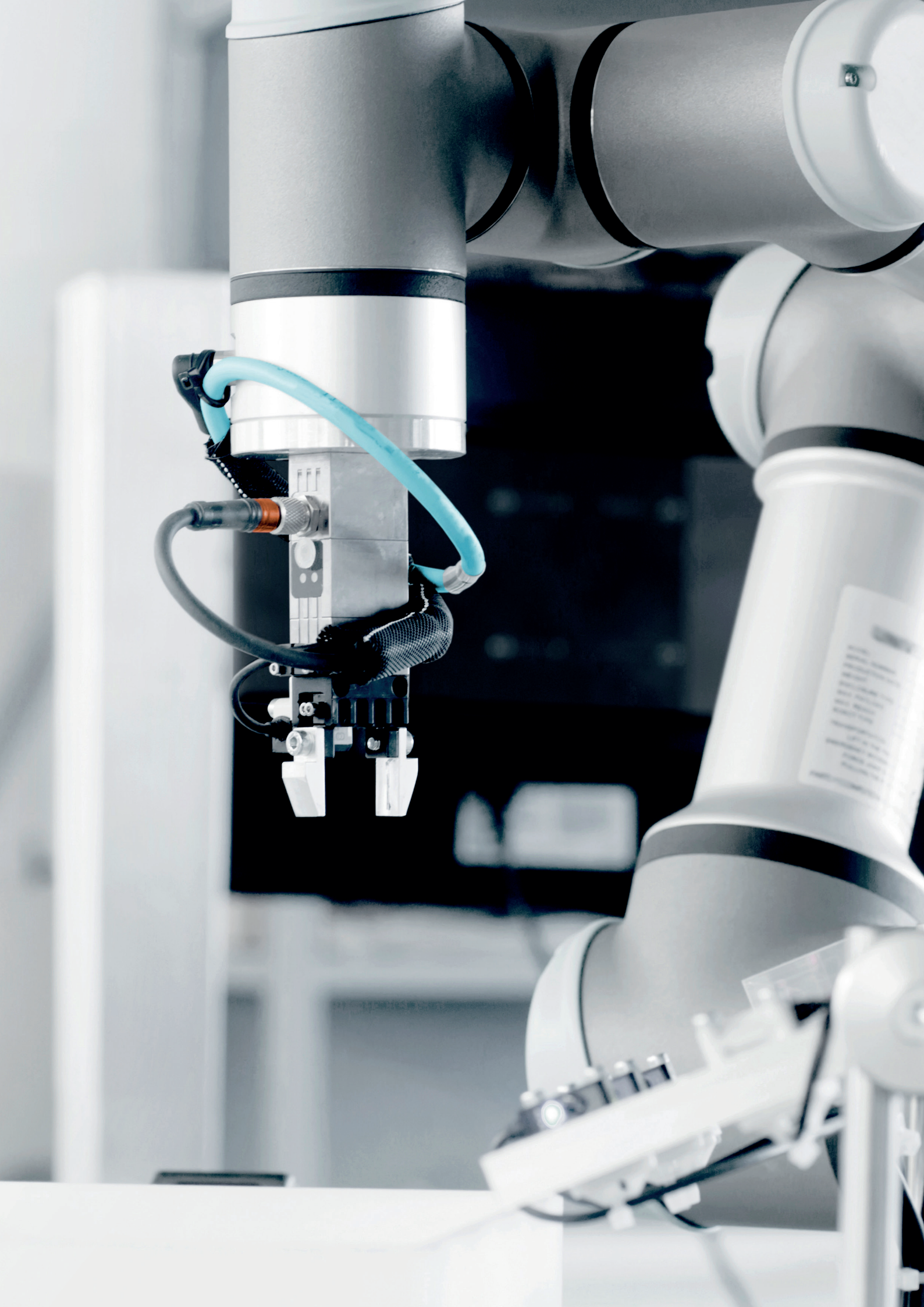

Robot Joint 45 $\varnothing 70$ mm, 70 Watt

Modular integrated Robot Joint

NEW

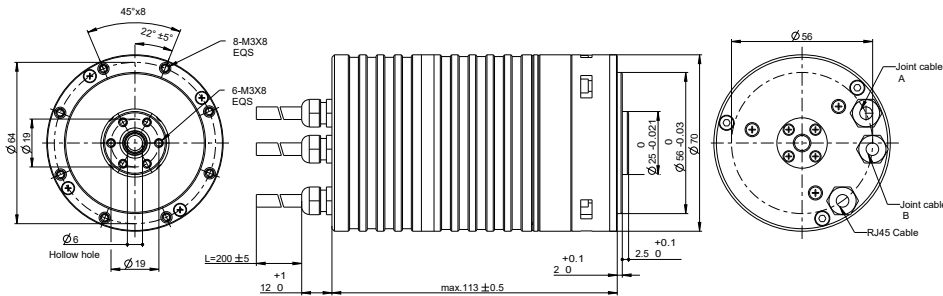

M 1:3

Technical data		
Outer diameter	m	70
Inner diameter	mm	6
Length	mm	L
Weight	kg	1.16
Nominal voltage	VDC	24
Nominal current	A	3.2
Motor/torque constant	mNm/A	37
Nominal torque (Gear ratio 101:1)	Nm	8
Acceleration/Deceleration torque (Gear ratio 101:1)	Nm	19
Nominal speed (Gear ratio 101:1)	rpm	49
Brake	--	YES
Brake voltage	VDC	24
Storage temperature	°C	20
Operation temperature	°C	-10 ... +70
Humidity		0 ... 70% non-condensing

Other specifications

Gear	
Reduction ratio	51:1, 81:1, 101:1

Incremental Encoder		
Resolution of incremental encoder	lines	500
Supply voltage	VDC	5±10%
Output current	mA	55±10%
Rise time	ns	180
Fall time	ns	40
Max. count frequency	kHz	100
High level output voltage	VDC	5±10%
Low level output voltage	VDC	0.4

Absolute Encoder		
Resolution of absolute encoder	bits	19
Maximum speed	rpm	10,000
Bandwidth	kHz	9
Sampling rate	kHz	18
Refresh rate	kHz	44
Supply voltage	VDC	5±0.5
Max. power consumption	mA	150
Precision of absolute encoder	°	0.1
Repeated precision of absolute encoder	°	0.001
Running range	°	+/-180
Maximum clock frequency	kHz	2000
Sample rate	kHz	18
Time out	µs	13.5

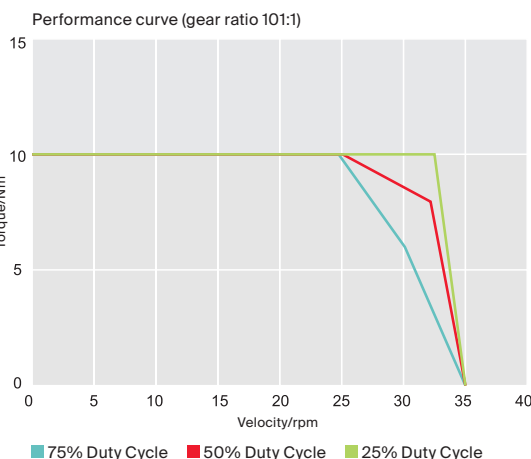
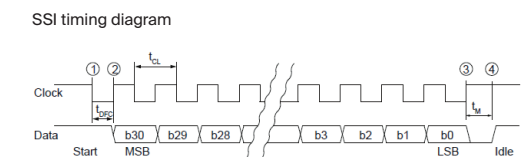
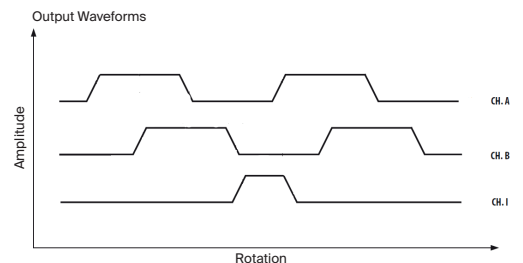

Joint Cable A			Joint Cable B		
Pin 1	VCC	Red	Pin 1	VCC	Red
Pin 2	GND	Black	Pin 2	GND	Black
Pin 3	Hall 1	Yellow	Pin 3	CLOCK+	Green
Pin 4	Hall 2	Brown	Pin 4	CLOCK-	Yellow
Pin 5	Hall 3	Orange	Pin 5	DATA+	Brown
Pin 6	CH A	Blue	Pin 6	DATA-	Orange
Pin 7	CH B	Green			
Pin 8	CH I	Purple			

RJ45 Cable A (AWG18)			RJ45 Cable A (AWG24)		
Pin 1	Winding 1	Red	Pin 1	Brake+	Brown
Pin 2	Winding 2	Black	Pin 2	Brake-	Blue
Pin 3	Winding 3	White			

Robot Joint 60 Ø80 mm, 100 Watt

Modular integrated Robot Joint

NEW

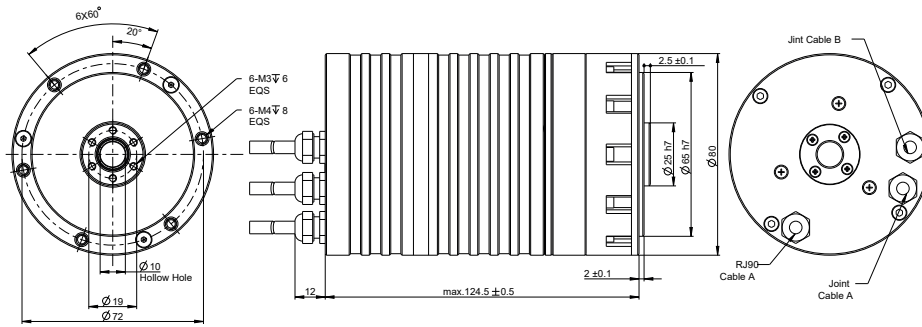

M 1:3

Technical data

Outer diameter	m	80
Inner diameter	mm	10
Length	mm	124.5
Weight	kg	2.5
Nominal voltage	VDC	24
Nominal current	A	5.5
Motor/torque constant	mNm/A	53.4
Nominal torque (Gear ratio 101:1)	Nm	22
Acceleration/Deceleration torque (Gear ratio 101:1)	Nm	57
Nominal speed (Gear ratio 101:1)	rpm	37
Brake	--	YES
Brake voltage	VDC	24
Storage temperature	°C	20
Operation temperature	°C	-10 ... +70
Humidity		0 ... 70 % non-condensing

Other specifications

Gear		
Reduction ratio		51:1, 81:1, 101:1, 121:1

Incremental Encoder		
Resolution of incremental encoder	lines	2048
Supply voltage	VDC	5±0.5
Output current	mA	55±10%
Rise time	ns	180
Fall time	ns	40
Max. count frequency	kHz	100
High level output voltage	VDC	5±10%
Low level output voltage	VDC	0.4

Absolute Encoder		
Resolution of absolute encoder	bits	19
Maximum speed	rpm	10,000
Bandwidth	kHz	9
Sampling rate	kHz	18
Refresh rate	kHz	44
Supply voltage	VDC	5±10%
Max. power consumption	mA	150
Precision of absolute encoder	°	0.1
Repeated precision of absolute encoder	°	0.001
Running range	°	+/-180
Maximum clock frequency	kHz	2000
Sample rate	kHz	18
Time out	µs	13.5

Joint Cable A			Joint Cable B		
Pin 1	VCC	Red	Pin 1	VCC	Red
Pin 2	GND	Black	Pin 2	GND	Black
Pin 3	Hall 1	Yellow	Pin 3	CLOCK+	Green
Pin 4	Hall 2	Brown	Pin 4	CLOCK-	Yellow
Pin 5	Hall 3	Orange	Pin 5	DATA+	Brown
Pin 6	CH A	Blue	Pin 6	DATA-	Orange
Pin 7	CH B	Green			
Pin 8	CH I	Purple			
RJ60 Cable A (AWG18)			RJ60 Cable A (AWG24)		
Pin 1	Winding 1	Red	Pin 1	Brake+	Brown
Pin 2	Winding 2	Black	Pin 2	Brake-	Blue
Pin 3	Winding 3	White			

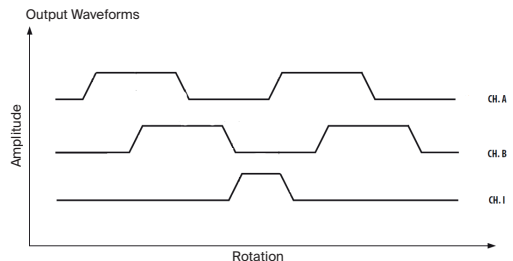

SSI timing diagram

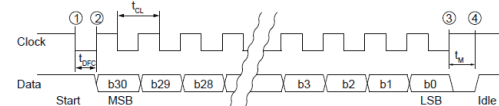

Performance curve gear ratio 101:1

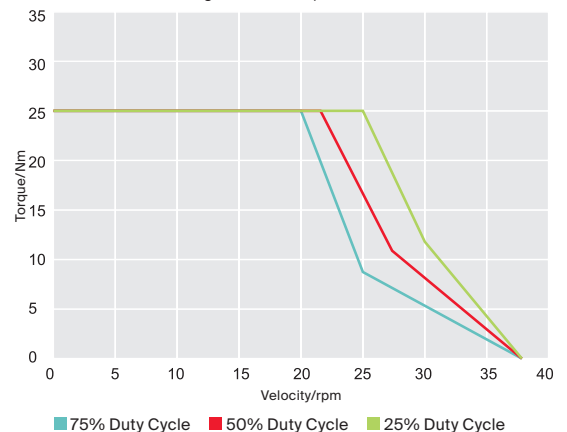

Robot Joint 90 \varnothing 110 mm, 260 Watt

Modular integrated Robot Joint

NEW

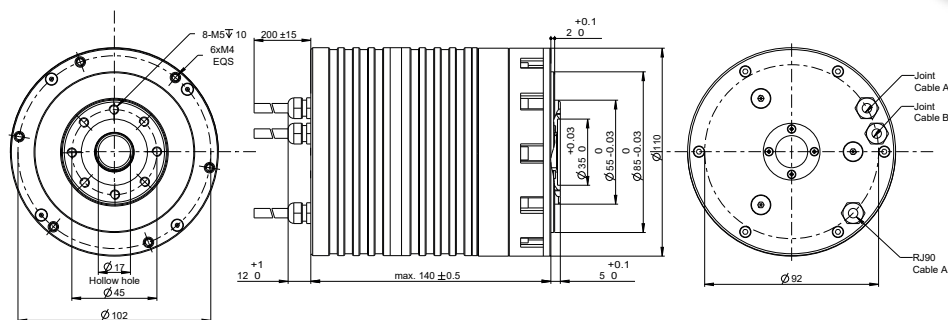

M 1:4

Technical data		
Outer diameter	m	110
Inner diameter	mm	17
Length	mm	L
Weight	kg	3.45
Nominal voltage	VDC	24
Nominal current	A	6
Motor/torque constant	mNm/A	71
Nominal torque (Gear ratio 101:1)	Nm	34
Acceleration/Deceleration torque (Gear ratio 101:1)	Nm	103
Nominal speed (Gear ratio 101:1)	rpm	27
Brake	--	YES
Brake voltage	VDC	24
Storage temperature	$^{\circ}$ C	20
Operation temperature	$^{\circ}$ C	-10 ... +70
Humidity		0 ... 70 % non-condensing

Other specifications

Gear	
Reduction ratio	51:1, 81:1, 101:1, 121:1, 161:1

Incremental Encoder		
Resolution of incremental encoder	lines	2048
Supply voltage	VDC	$5 \pm 10\%$
Output current	mA	$55 \pm 10\%$
Rise time	ns	180
Fall time	ns	49
Max. count frequency	kHz	100
High level output voltage	VDC	$5 \pm 10\%$
Low level output voltage	VDC	0.4

Absolute Encoder		
Resolution of absolute encoder	bits	19
Maximum speed	rpm	10,000
Bandwidth	kHz	9
Sampling rate	kHz	18
Refresh rate	kHz	44
Supply voltage	VDC	$5 \pm 10\%$
Max. power consumption	mA	150
Precision of absolute encoder	$^{\circ}$	0.1
Repeated precision of absolute encoder	$^{\circ}$	0.001
Running range	$^{\circ}$	± 180
Maximum clock frequency	kHz	2000
Sample rate	kHz	18
Time out	Us	13.5

Joint Cable A			Joint Cable B		
Pin 1	VCC	Red	Pin 1	VCC	Red
Pin 2	GND	Black	Pin 2	GND	Black
Pin 3	Hall 1	Yellow	Pin 3	CLOCK+	Green
Pin 4	Hall 2	Brown	Pin 4	CLOCK-	Yellow
Pin 5	Hall 3	Orange	Pin 5	DATA+	Brown
Pin 6	CH A	Blue	Pin 6	DATA-	Orange
Pin 7	CH B	Green			
Pin 8	CH I	Purple			

RJ90 Cable A (AWG18)			RJ90 Cable A (AWG24)		
Pin 1	Winding 1	Red	Pin 1	Brake+	Brown
Pin 2	Winding 2	Black	Pin 2	Brake-	Blue
Pin 3	Winding 3	White			

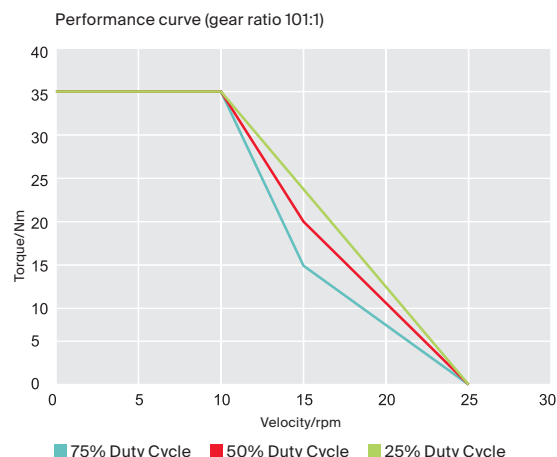
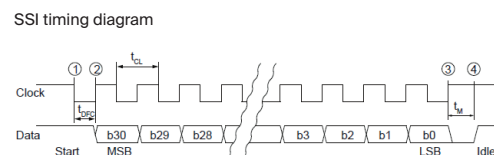
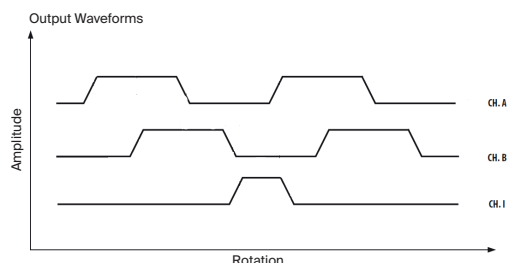

Sold & Serviced By:



Toll Free Phone (877) SERV098
www.electromate.com
sales@electromate.com