



Climbing with maxon drives

A robot able to climb transmission towers makes short work of routine checks. Equipped with powerful maxon drives, autonomous robots can go almost anywhere, to great heights or into narrow cable ducts.

A technician is standing at the foot of a transmission tower, looking up. There is urgent maintenance to be done. In earlier times he would have needed to climb up the tower himself, but no longer. Today, he uses his tablet computer to control a small robot, which slowly rides up the transmission tower on a rail. Equipped with a swiveling camera, the robot sends images and videos to the tablet in real time. This allows the technician to quickly identify and eliminate problems. However, the applications of this robot are not limited to transmission towers. It can also be used to combat fires in cable ducts, wind turbines, or buildings. For this purpose, it can be equipped with a modular fire extinguisher cartridge. As a fire-fighting robot, it can go on patrol to automatically detect and extinguish fires.

The Zurich-based engineering company HighStep Systems AG developed the HSS Robo II to make the daily work of technicians easier. The HighStep Robo is electrically powered and moves along a vertical or horizontal rail. Inspection and monitoring of transmission towers are only two of many possible fields of application. As long as it has a HighStep rail to ride on, the robot can go almost anywhere, to can reach great heights or travel through narrow cable ducts. With its integrated control module, it can be used to carry out a range of tasks, either by remote control or autonomously. The control is implemented via a browser and optimized for all devices, including desktop and tablet PCs, as well as smartphones. Power is supplied from rechargeable battery with a capacity for up to 1.5 hours of operation. The robot is equipped with various sensors whose functions include collision protection and monitoring the battery status.

Authors: Anja Schütz, Stefan Roschi © 2014 maxon motor ag

Powerful drive on four wheels

The robot is driven by two 150-watt maxon RE 40 motors with planetary gearheads. Due to its high motor power, the robot is able to carry loads weighing up to 60 kilogram. maxon RE motors are energy-efficient DC motors with an efficiency of more than 90 percent. The brushed motors use ironless windings and neodymium magnets for maximum performance in a very compact format. Precise control is provided by the maxon ESCON 50/5 servo controller. This high-performance controller can be configured via USB using the graphic user interface of the ESCON Studio software, which makes it very simple to operate for the end user.

Author: Anja Schütz, Editor, maxon motor ag

Application story: 2500 characters, 494 words, 4 figures

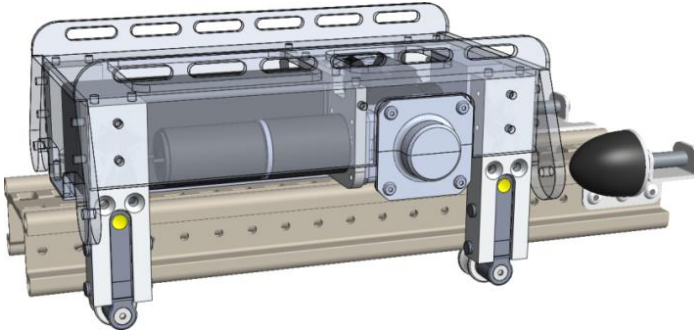

Fig. 2: View inside the robot with maxon drives visible. © 2014 HighStep Systems AG



Fig. 3: The maxon ESCON 50/5 servo controller.
© 2014 maxon motor ag



Fig. 4: Two maxon RE 40 motors are used in the climbing robot together with planetary gearheads.
© 2014 maxon motor ag

For additional information, contact:

maxon motor ag
Brünigstrasse 220
PO Box 263
CH-6072 Sachseln

Phone +41 41 666 15 00
Fax +41 41 666 16 50
Web www.maxonmotor.com

HighStep Systems AG
Blumenfeldstrasse 51
CH-8046 Zurich

Phone +41 44 371 44 33
Web www.highstepsystems.com