

maxon **X**drives

# Custom-made DC motors, gearheads, encoders.

Configurable online and ready for delivery within 11 days.

**NEW**



**HIGH  
SPEED**

First DCX, now ECX:  
The new configurable BLDC motors from page 39

[xdrives.maxonmotor.com](http://xdrives.maxonmotor.com)

**maxon motor**

driven by precision

**NEW**

## Brushed DC motors **maxon DCX**

### **Powerful**

Up to 120 W continuous output power, robust and very quiet.

### **Highly dynamic**

Patented ironless winding and the latest magnetic material.

### **Efficient**

Efficiency of more than 90 %.

## **maxon DC-max**

### **Cost-effective**

Unrivalled price-performance ratio.

### **Dynamic**

Patented ironless winding and the latest magnetic material.

### **Efficient**

Efficiency of almost 90 %.

## Brushless DC motors **maxon ECX**

### **High speed**

Up to 120000 rpm, smooth-running, almost no heat development.

### **Efficient**

Efficiency of more than 90 %.

### **Large selection**

Various power stage options and diameters, electrical and mechanical interfaces.

### **Sterilizable**

Sterilizable for up to 2000 cycles.

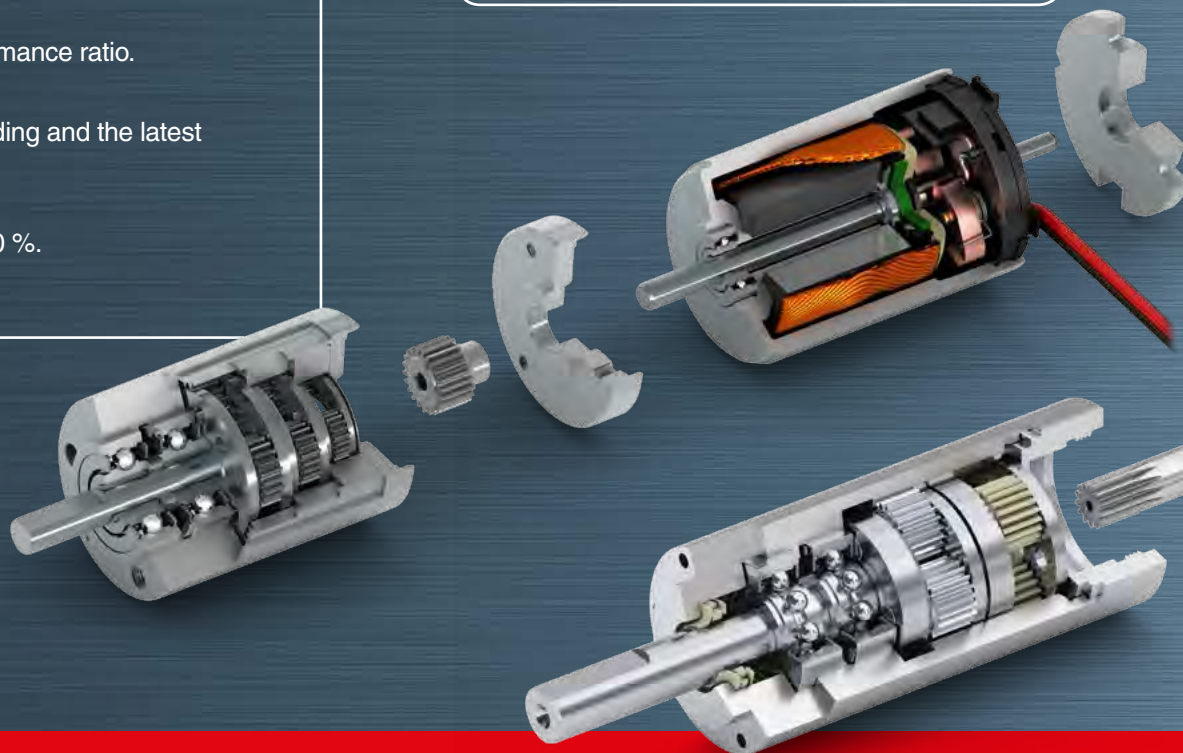



maxon X drives

# The best maxon drives at a glance.

Configure your drive online – in accordance with your individual needs. Mechanical and electrical data, dimensional drawings and CAD files can be downloaded immediately after the configuration has been completed. Within 11 working days, your drive will be ready for shipment.

## Planetary gearhead maxon GPX

### Modular

High number of variants for different applications.

### High power density

Transmission of high torques and speeds.

### High efficiency

Up to 90 %.

### Sterilizable

Sterilizable for up to 2000 cycles.

## Encoder

## maxon ENX

### Compact

Metal housing with a length of only 8.5 mm.

### Robust

Mechanically robust housing and interference-free operation.

### Differential signals

3-channel encoder with differential output signals.

### Flexible

Counts per turn can be custom programmed at the factory – 1 to 1024 cpt.

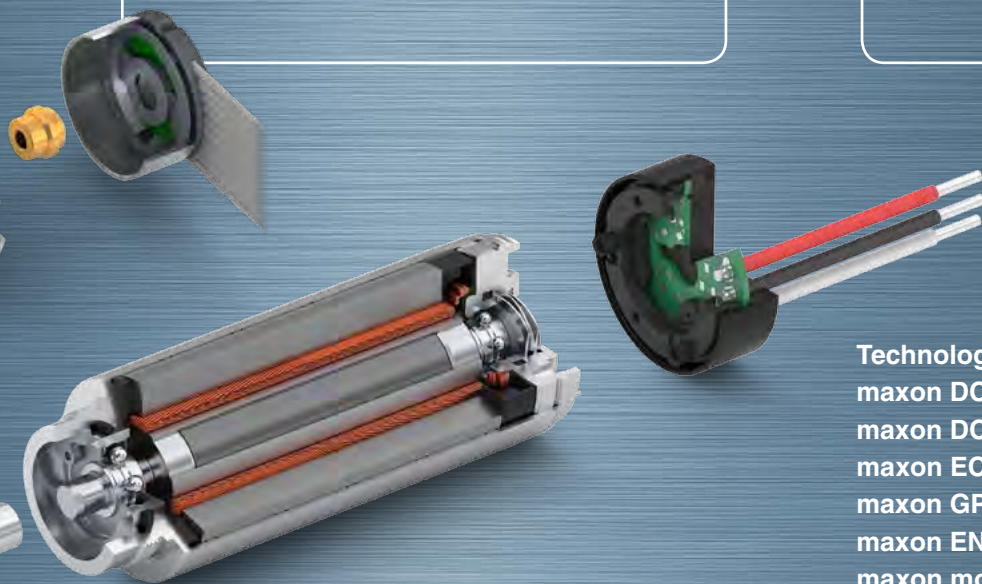

Technology	2–10
maxon DCX motor	11–32
maxon DC-max motor	33–38
maxon ECX motor	39–54
maxon GPX gear	55–78
maxon ENX encoder	79–84
maxon motor control	85–86
When it really matters.	87–91

[xdrives.maxonmotor.com](http://xdrives.maxonmotor.com)

**maxon motor**

driven by precision

maxon X drives

# Produced within 11 days.

Lean, automated processes ensure that all drive versions are ready for shipment within 11 days.

Assemble your individual brushed or brushless DC drive: You can configure the gear stages, the motor bearings, the shafts, the encoder and much more. Design your custom drive online today and your finished drive will ship from Switzerland in 11 working days.

[xdrives.maxonmotor.com](http://xdrives.maxonmotor.com)





# 11 READY IN DAYS



**maxon motor**

driven by precision

maxon DCX

# Configure your DC drive.

## GEARHEAD VERSION

Standard  
Ceramic  
Noise reduced  
Backlash reduced  
High Power

## REDUCTION

3.9:1 ... 1526:1

## FLANGE

Mounting threads

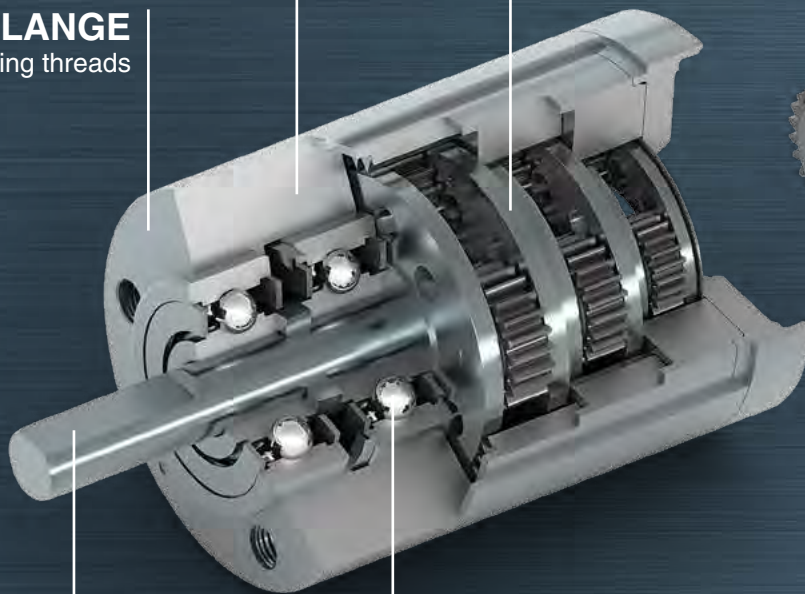

## SHAFT

Length  
Flat face  
Cross hole  
Feather key

## BEARING MODULE

Standard

## FLANGE

Mounting threads  
Centering collar

## SHAFT

Length  
Diameter  
Flat face

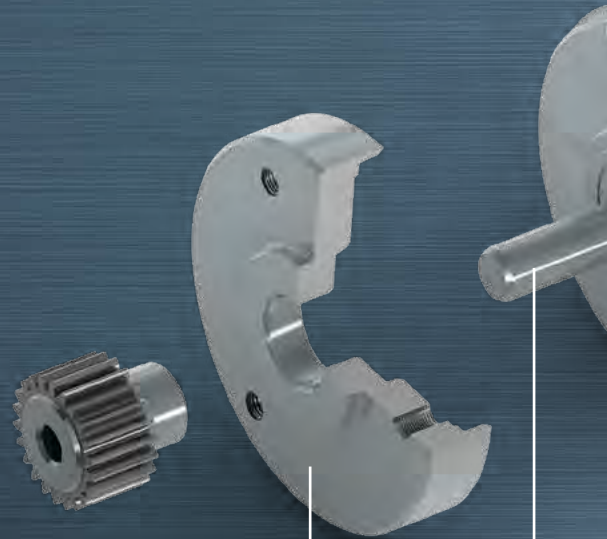



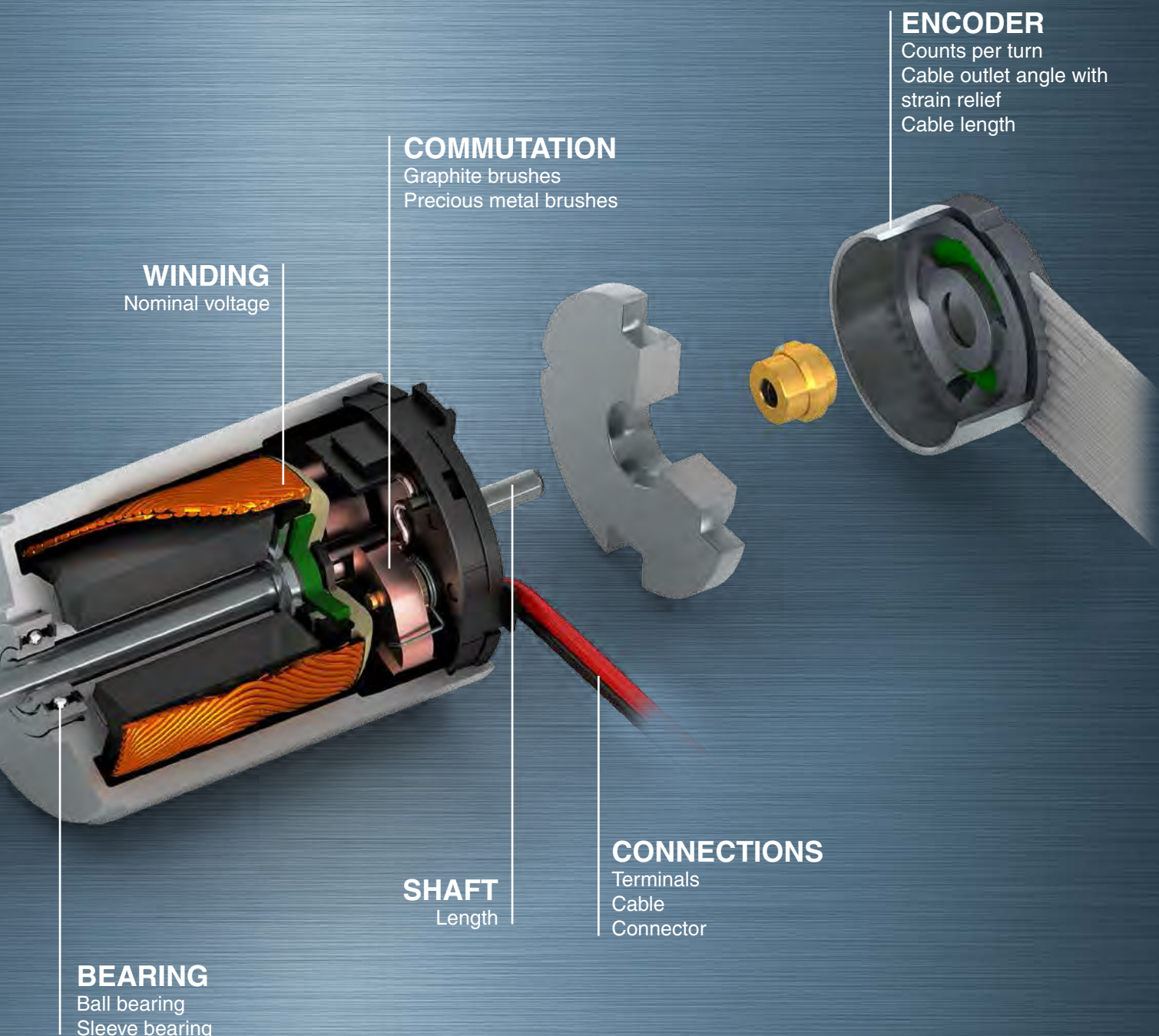

**WINDING**  
Nominal voltage

**BEARING**  
Ball bearing  
Sleeve bearing

**SHAFT**  
Length

**COMMUTATION**  
Graphite brushes  
Precious metal brushes

**CONNECTIONS**  
Terminals  
Cable  
Connector

**ENCODER**  
Counts per turn  
Cable outlet angle with strain relief  
Cable length

[dcx.maxonmotor.com](http://dcx.maxonmotor.com)

**maxon motor**  
driven by precision

maxon ECX

# Configure your BLDC drive.

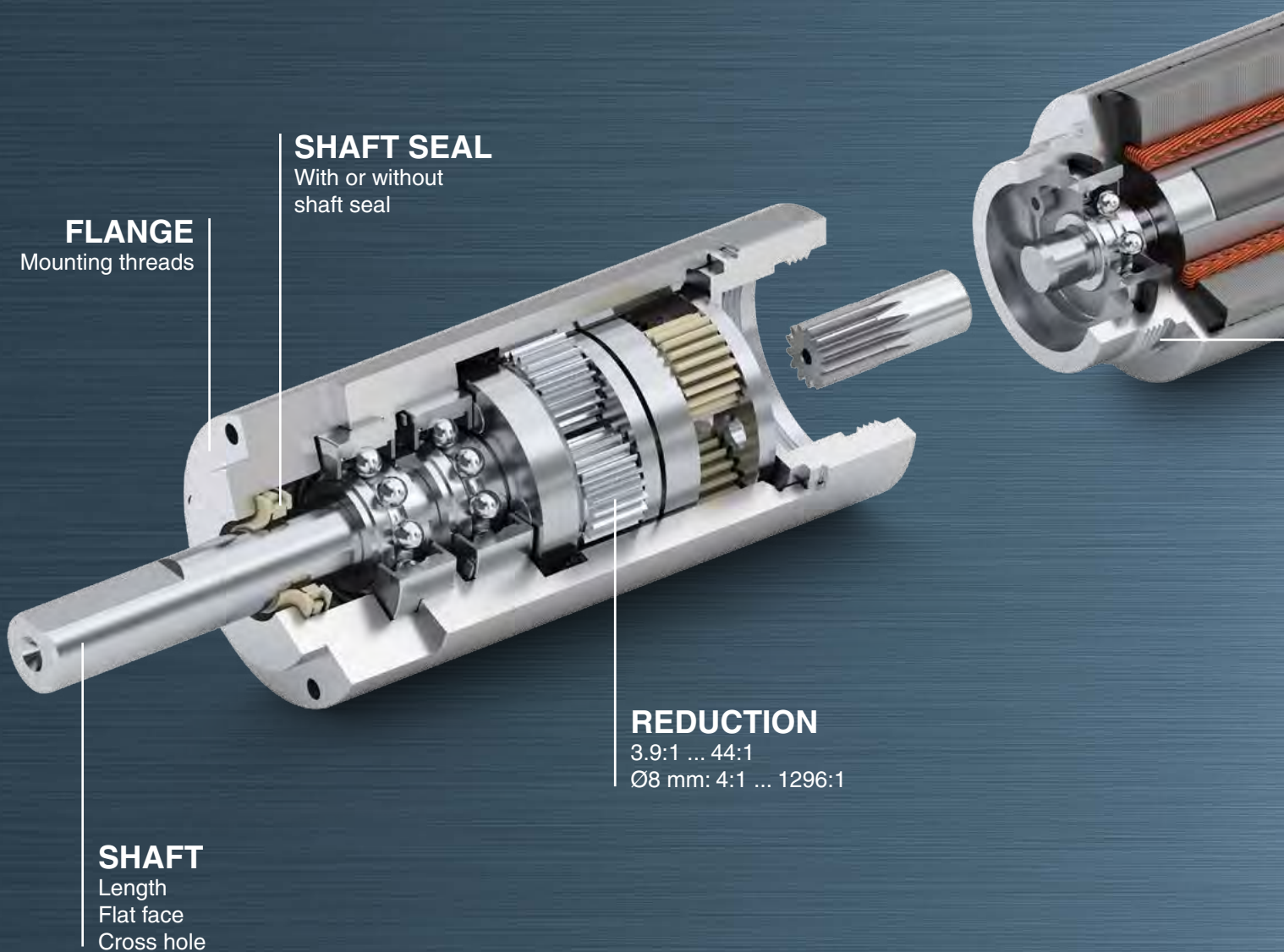

**FLANGE**  
Mounting threads

**SHAFT SEAL**  
With or without  
shaft seal

**SHAFT**  
Length  
Flat face  
Cross hole

**REDUCTION**  
3.9:1 ... 44:1  
Ø8 mm: 4:1 ... 1296:1



## SENSORS

Sensorless or with Hall Sensors  
Thermal sensor NTC  
Encoder Incremental  
Encoder Absolute

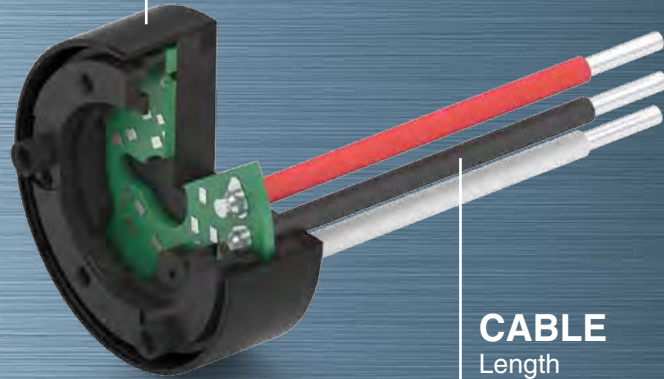

## CABLE

Length  
Ø8 mm: Insulation

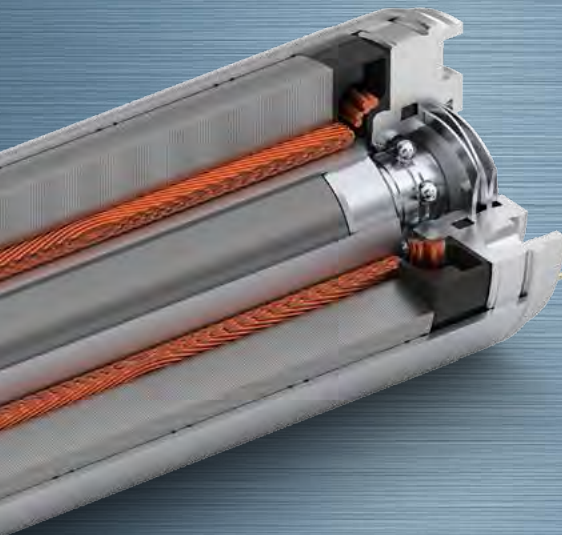

## WINDING

Nominal voltage

## FLANGE

Mounting threads  
External thread

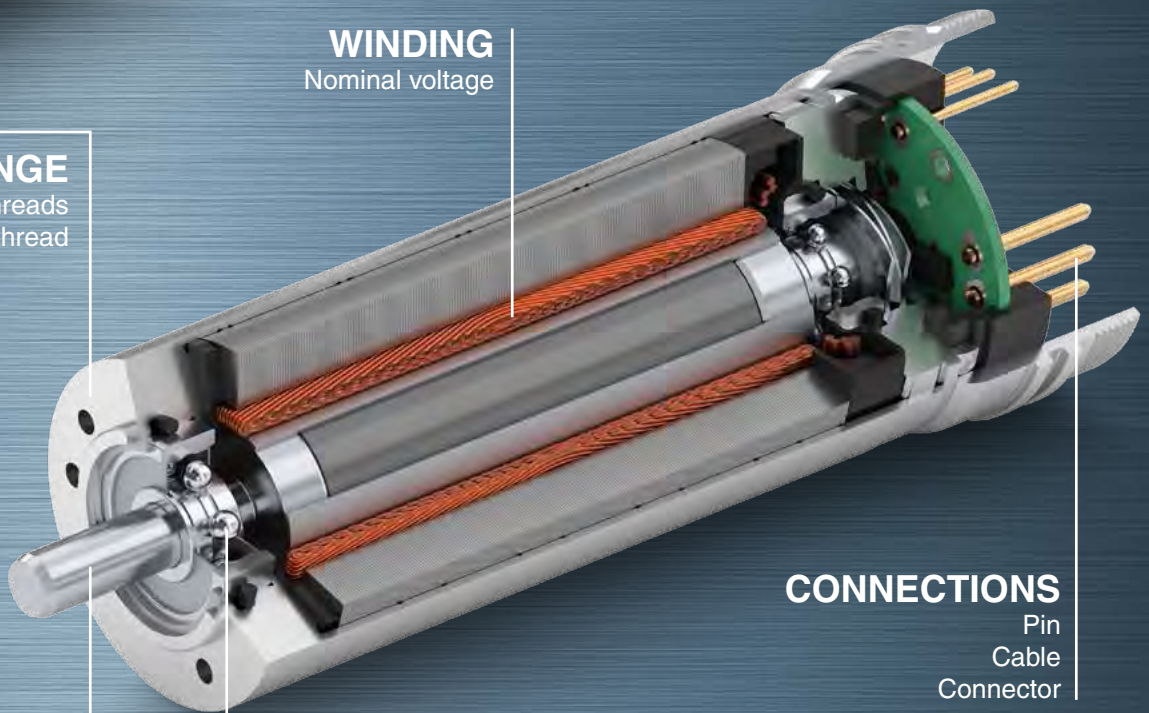

## CONNECTIONS

Pin  
Cable  
Connector

## SHAFT

Length  
Diameter

## BEARINGG

Ball bearing steel  
Ball bearing ceramic

[ecx.maxonmotor.com](http://ecx.maxonmotor.com)

**maxon motor**

driven by precision



# Fast Processing – Worldwide Network.

Configure and order your drive online:  
[xdrives.maxonmotor.com](http://xdrives.maxonmotor.com)

## Headquarters

maxon motor ag  
Brünigstrasse 220  
P.O. Box 263  
6072 Sachseln  
Switzerland

+41 (41) 666 15 00  
[contact.maxonmotor.com](mailto:contact.maxonmotor.com)

**maxon motor**

driven by precision



# maxon DCX

## Brushed DC motors maxon DCX

maxon DCX motors make an impression with their unsurpassed power density (torque/motor volume ratio) and their absolute quiet running. The robust construction together with the worldwide patented ironless rotor make the DCX motors a highly dynamic drive in almost any situation.

maxon DCX motors can be configured online and are ready for delivery within 11 working days.

[dcx.maxonmotor.com](http://dcx.maxonmotor.com)

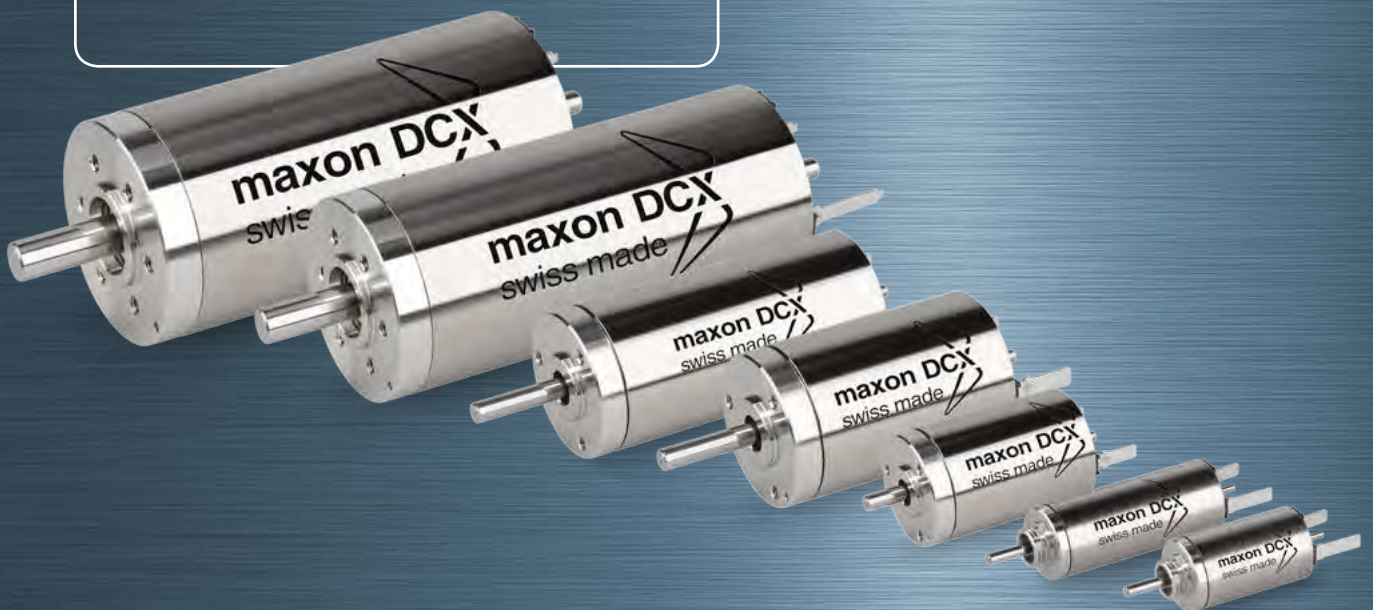

**maxon motor**

driven by precision

# DCX 10 S Precious Metal Brushes

## DC motor Ø10 mm



1/1.4 W 0.9 mNm 14300 rpm

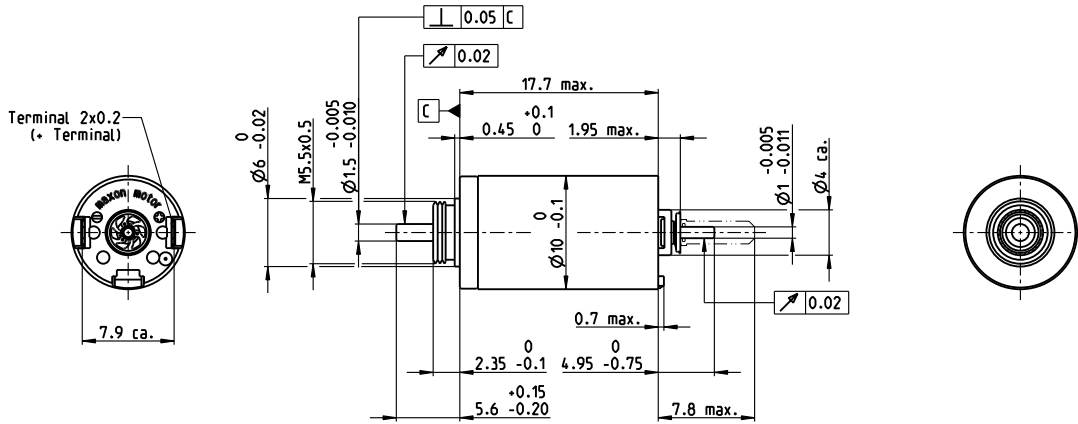

M 3:2

### Motor Data

1_	Nominal voltage	V	1.5	3	4.5	6	9	12
2_	No load speed	rpm	12800	13100	12700	12700	12700	12700
3_	No load current	mA	84.9	44.2	28.3	21.2	14.1	10.6
4_	Nominal speed	rpm	4580	4750	4320	4150	3970	3930
5_	Nominal torque (max. continuous torque)	mNm	0.911	0.94	0.936	0.919	0.902	0.898
6_	Nominal current (max. continuous current)	A	0.924	0.49	0.316	0.233	0.152	0.114
7_	Stall torque	mNm	1.47	1.52	1.47	1.41	1.36	1.35
8_	Stall current	A	1.39	0.742	0.463	0.335	0.215	0.16
9_	Max. efficiency	%	58	58	58	57	56	56
10_	Terminal resistance	Ω	1.08	4.04	9.72	17.9	41.8	74.9
11_	Terminal inductance	mH	0.019	0.073	0.173	0.307	0.692	1.23
12_	Torque constant	mNm/A	1.05	2.05	3.16	4.22	6.33	8.44
13_	Speed constant	rpm/V	9050	4660	3020	2260	1510	1130
14_	Speed/torque gradient	rpm/mNm	9230	9170	9260	9610	9960	10000
15_	Mechanical time constant	ms	7.41	7.35	7.37	7.38	7.43	7.43
16_	Rotor inertia	gcm <sup>2</sup>	0.077	0.077	0.076	0.073	0.071	0.071

### Thermal data

17_	Thermal resistance housing-ambient	K/W	37.6
18_	Thermal resistance winding-housing	K/W	22.0
19_	Thermal time constant winding	s	4.69
20_	Thermal time constant motor	s	156
21_	Ambient temperature ball bearings	°C	-30...+85
21_	Ambient temperature sleeve bearings	°C	-30...+85
22_	Max. winding temperature	°C	100

### Operating Range

n [rpm] Winding 4.5 V

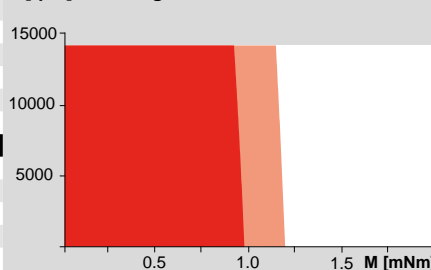

■ Continuous operation  
 ■ Continuous operation with reduced thermal resistance  $R_{th2}$  50%  
 □ Intermittent operation

### Mechanical data ball bearings

23_	Max. speed	rpm	14300
24_	Axial play	mm	0...0.1
	Preload	N	0.5
25_	Radial play	mm	0.015
26_	Max. axial load (dynamic)	N	0.5
27_	Max. force for press fits (static)	N	8.8
	(static, shaft supported)	N	120
28_	Max. radial load [mm from flange]	N	1.5 [5]

### Mechanical data sleeve bearings

23_	Max. speed	rpm	14300
24_	Axial play	mm	0...0.15
	Preload	N	0
25_	Radial play	mm	0.015
26_	Max. axial load (dynamic)	N	0.1
27_	Max. force for press fits (static)	N	30
	(static, shaft supported)	N	120
28_	Max. radial load [mm from flange]	N	0.8 [5]

### Other specifications

29_	Number of pole pairs		1
30_	Number of commutator segments		7
31_	Weight of motor	g	6.3
32_	Typical noise level	dBA	35

### maxon Modular System

<b>maxon gear</b>	Stages	<b>maxon sensor</b>	<b>maxon motor control</b>
57_GPX 10 A	1-5	82_ENX 10 EASY	378_ESCON Module 24/2
		82_ENX 10 QUAD	378_ESCON 36/2 DC
			386_EPOS2 24/2 (DC/EC)
			386_EPOS2 Module 36/2

### Configuration

Bearing: Sleeve bearings/ball bearings preloaded  
 Commutation: Precious metal brushes with or without CLL  
 Flange front/back: Standard flange/Flange with thread holes/no flange  
 Shaft front/back: Length  
 Electric connection: Terminals or cable/cable length/connector type

xdrives.maxonmotor.com



# DCX 10 L Precious Metal Brushes

## DC motor Ø10 mm



1.5/3 W 2.2 mNm 14300 rpm

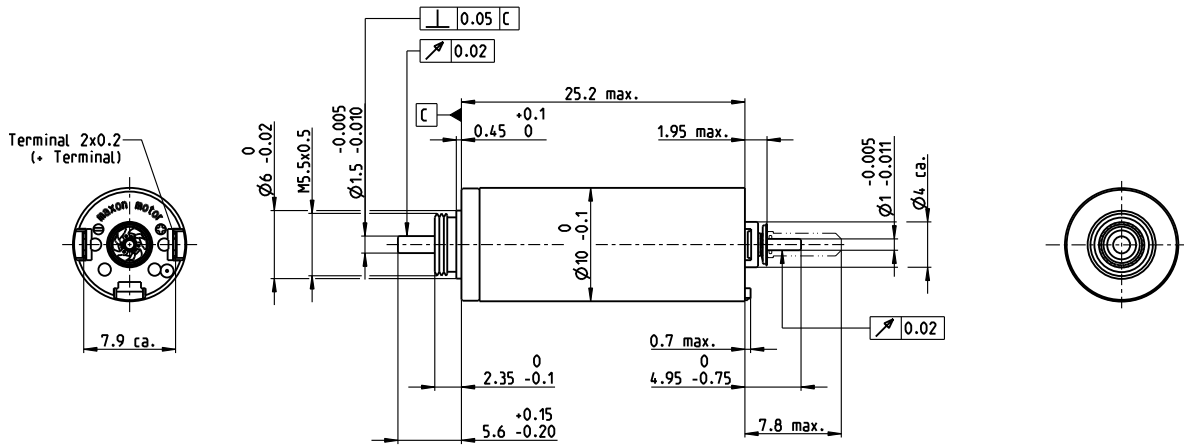

M 3:2

### Motor Data

1_	Nominal voltage	V	1.5	3	4.5	6	9	12
2_	No load speed	rpm	11500	12100	11900	12100	11900	11200
3_	No load current	mA	83.5	45.1	29.3	22.5	14.6	10
4_	Nominal speed	rpm	9180	6910	7090	6620	6760	5960
5_	Nominal torque (max. continuous torque)	mNm	1.04	2.05	2.2	1.94	2.06	2.03
6_	Nominal current (max. continuous current)	A	0.924	0.919	0.646	0.435	0.303	0.211
7_	Stall torque	mNm	5.15	4.83	5.48	4.34	4.82	4.39
8_	Stall current	A	4.23	2.09	1.55	0.937	0.682	0.439
9_	Max. efficiency	%	74	73	75	72	74	73
10_	Terminal resistance	Ω	0.355	1.44	2.9	6.4	13.2	27.3
11_	Terminal inductance	mH	0.006	0.021	0.050	0.086	0.199	0.399
12_	Torque constant	mNm/A	1.22	2.32	3.54	4.63	7.07	10.0
13_	Speed constant	rpm/V	7830	4120	2700	2060	1350	955
14_	Speed/torque gradient	rpm/mNm	2280	2560	2220	2850	2520	2610
15_	Mechanical time constant	ms	3.64	3.53	3.5	3.54	3.53	3.56
16_	Rotor inertia	gcm <sup>2</sup>	0.153	0.132	0.151	0.119	0.134	0.130

### Thermal data

17_	Thermal resistance housing-ambient	K/W	36.5
18_	Thermal resistance winding-housing	K/W	10.6
19_	Thermal time constant winding	s	3.94
20_	Thermal time constant motor	s	151
21_	Ambient temperature ball bearings	°C	-30...+85
21_	Ambient temperature sleeve bearings	°C	-30...+85
22_	Max. winding temperature	°C	100

### Operating Range

n [rpm] Winding 4.5 V

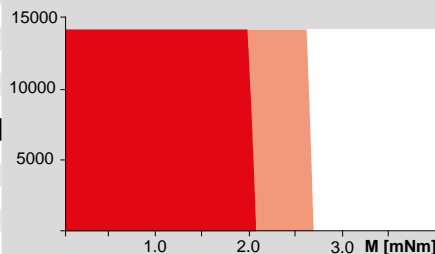

■ Continuous operation  
 ■ Continuous operation with reduced thermal resistance  $R_{th2}$  50%  
 ■ Intermittent operation

### Mechanical data ball bearings

23_	Max. speed	rpm	14300
24_	Axial play	mm	0...0.1
	Preload	N	0.5
25_	Radial play	mm	0.015
26_	Max. axial load (dynamic)	N	0.5
27_	Max. force for press fits (static)	N	8.8
	(static, shaft supported)	N	120
28_	Max. radial load [mm from flange]	N	1.5 [5]

### Mechanical data sleeve bearings

23_	Max. speed	rpm	14300
24_	Axial play	mm	0...0.15
	Preload	N	0
25_	Radial play	mm	0.015
26_	Max. axial load (dynamic)	N	0.1
27_	Max. force for press fits (static)	N	30
	(static, shaft supported)	N	120
28_	Max. radial load [mm from flange]	N	0.8 [5]

### Other specifications

29_	Number of pole pairs		1
30_	Number of commutator segments		7
31_	Weight of motor	g	11
32_	Typical noise level	dB(A)	37

### maxon Modular System

maxon gear	Stages	maxon sensor	maxon motor control
57_GPX 10 A	1-5	82_ENX 10 EASY	378_ESCON Module 24/2
		82_ENX 10 QUAD	378_ESCON 36/2 DC
			386_EPOS2 24/2 (DC/EC)
			386_EPOS2 Module 36/2

### Configuration

Bearing: Sleeve bearings/ball bearings preloaded  
 Commutation: Precious metal brushes with or without CLL  
 Flange front/back: Standard flange/Flange with thread holes/no flange  
 Shaft front/back: Length  
 Electric connection: Terminals or cable/cable length/connector type

[xdrives.maxonmotor.com](http://xdrives.maxonmotor.com)

# DCX 12 S Precious Metal Brushes

## DC motor Ø12 mm

1.6/2 W 2.0 mNm 14300 rpm

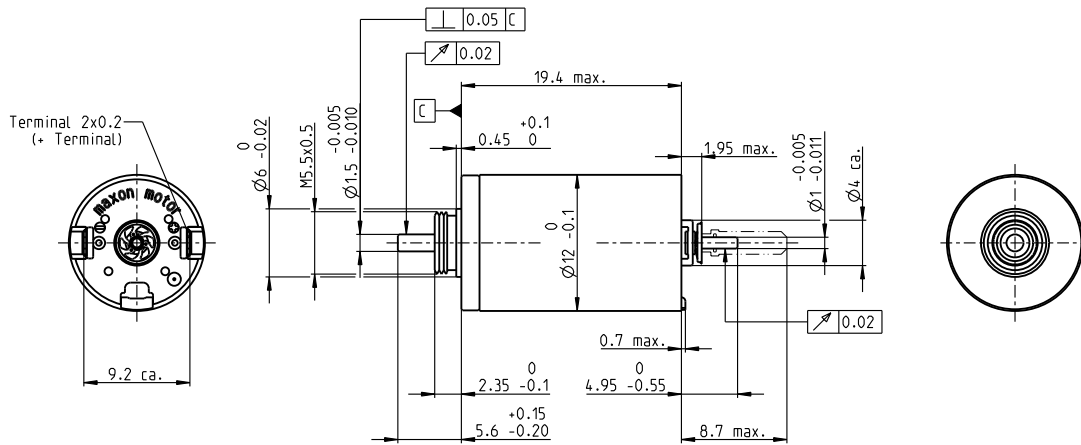

M 3:2

### Motor Data

1_	Nominal voltage	V	1.5	3	4.5	6	9	12
2_	No load speed	rpm	8870	9130	9040	9130	9050	9060
3_	No load current	mA	42.2	21.9	14.4	11	7.21	5.42
4_	Nominal speed	rpm	4590	3730	3600	3840	3680	3600
5_	Nominal torque (max. continuous torque)	mNm	1.41	1.96	1.94	1.99	1.96	1.92
6_	Nominal current (max. continuous current)	A	0.924	0.655	0.427	0.332	0.216	0.159
7_	Stall torque	mNm	2.96	3.36	3.26	3.48	3.35	3.23
8_	Stall current	A	1.87	1.09	0.701	0.566	0.36	0.261
9_	Max. efficiency	%	72	74	74	75	74	74
10_	Terminal resistance	Ω	0.801	2.74	6.42	10.6	25	46
11_	Terminal inductance	mH	0.0162	0.0615	0.141	0.246	0.564	0.998
12_	Torque constant	mNm/A	1.58	3.08	4.65	6.15	9.31	12.4
13_	Speed constant	rpm/V	6050	3110	2050	1550	1030	771
14_	Speed/torque gradient	rpm/mNm	3070	2770	2830	2680	2760	2870
15_	Mechanical time constant	ms	8.64	8.29	8.24	8.22	8.25	8.25
16_	Rotor inertia	gcm <sup>2</sup>	0.269	0.286	0.278	0.293	0.286	0.275

### Thermal data

17_	Thermal resistance housing-ambient	K/W	35
18_	Thermal resistance winding-housing	K/W	14.4
19_	Thermal time constant winding	s	7.67
20_	Thermal time constant motor	s	146
21_	Ambient temperature ball bearings	°C	-30...+85
21_	Ambient temperature sleeve bearings	°C	-30...+85
22_	Max. winding temperature	°C	100

### Operating Range

n [rpm] Winding 4.5 V

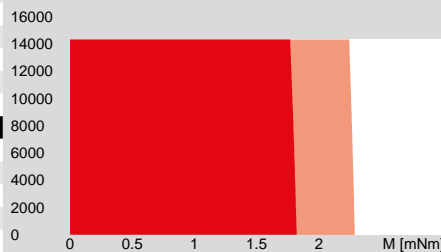

■ Continuous operation  
■ Continuous operation with reduced thermal resistance  $R_{th2}$  50%  
■ Intermittent operation

### Mechanical data ball bearings

23_	Max. speed	rpm	14300
24_	Axial play	mm	0...0.1
	Preload	N	0.5
25_	Radial play	mm	0.015
26_	Max. axial load (dynamic)	N	0.5
27_	Max. force for press fits (static)	N	8.8
	(static, shaft supported)	N	120
28_	Max. radial load [mm from flange]	N	1.5 [5]

### Mechanical data sleeve bearings

23_	Max. speed	rpm	14300
24_	Axial play	mm	0...0.15
	Preload	N	0
25_	Radial play	mm	0.015
26_	Max. axial load (dynamic)	N	0.1
27_	Max. force for press fits (static)	N	30
	(static, shaft supported)	N	120
28_	Max. radial load [mm from flange]	N	0.8 [5]

### maxon Modular System

<b>maxon gear</b>	Stages	<b>maxon sensor</b>	<b>maxon motor control</b>
64_GPX 12 A	1-2	82_ENX 10 EASY	378_ESCON Module 24/2
60_GPX 14 A, C	3-4	82_ENX 10 QUAD	378_ESCON 36/2 DC
61_GPX 14 LN, LZ	3-4		386_EPOS2 24/2 (DC/EC)
			386_EPOS2 Module 36/2

### Other specifications

29_	Number of pole pairs		1
30_	Number of commutator segments		7
31_	Weight of motor	g	11
32_	Typical noise level	dB(A)	40

### Configuration

Bearing: Sleeve bearings/ball bearings preloaded  
 Commutation: Precious metal brushes with or without CLL  
 Flange front/back: Standard flange/Flange with thread holes/no flange  
 Shaft front/back: Length  
 Electric connection: Terminals or cable/cable length/connector type

xdrives.maxonmotor.com



# DCX 12 L Precious Metal Brushes

## DC motor Ø12 mm

2.5/4.8 W 4.2 mNm 12000 rpm

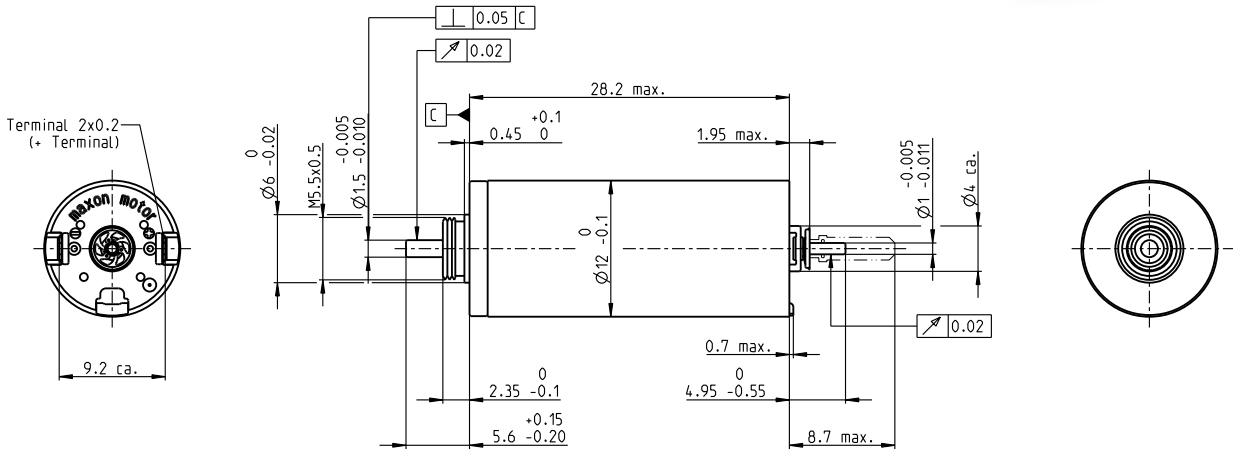

M 3:2

### Motor Data

1_	Nominal voltage	V	3	4.5	6	9	12	18
2_	No load speed	rpm	8680	8690	8690	8700	8690	8690
3_	No load current	mA	33.9	22.6	17.0	11.3	8.49	5.66
4_	Nominal speed	rpm	6140	5570	5470	5680	5490	5470
5_	Nominal torque (max. continuous torque)	mNm	2.92	4.07	3.93	4.18	3.94	3.92
6_	Nominal current (max. continuous current)	A	0.924	0.85	0.616	0.436	0.308	0.204
7_	Stall torque	mNm	10.0	11.4	10.7	12.1	10.8	10.6
8_	Stall current	A	3.08	2.32	1.63	1.23	0.824	0.543
9_	Max. efficiency	%	80	81	81	82	81	81
10_	Terminal resistance	Ω	0.975	1.94	3.68	7.29	14.6	33.1
11_	Terminal inductance	mH	0.031	0.071	0.125	0.282	0.502	1.13
12_	Torque constant	mNm/A	3.26	4.90	6.53	9.79	13.1	19.6
13_	Speed constant	rpm/V	2930	1950	1460	975	731	488
14_	Speed/torque gradient	rpm/mNm	874	772	824	726	816	825
15_	Mechanical time constant	ms	4.43	4.31	4.28	4.25	4.26	4.27
16_	Rotor inertia	gcm <sup>2</sup>	0.484	0.533	0.496	0.559	0.498	0.495

### Thermal data

17_	Thermal resistance housing-ambient	K/W	31
18_	Thermal resistance winding-housing	K/W	10.3
19_	Thermal time constant winding	s	10.1
20_	Thermal time constant motor	s	194
21_	Ambient temperature ball bearings	°C	-30...+85
21_	Ambient temperature sleeve bearings	°C	-30...+85
22_	Max. winding temperature	°C	100

### Operating Range

n [rpm] Winding 4.5 V

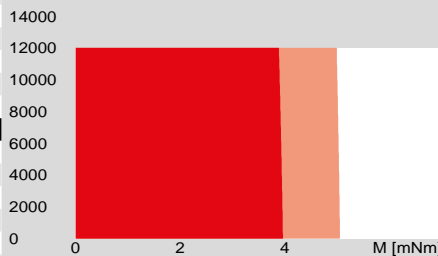

■ Continuous operation  
 ■ Continuous operation with reduced thermal resistance  $R_{th2}$  50%  
 ■ Intermittent operation

### Mechanical data ball bearings

23_	Max. speed	rpm	12000
24_	Axial play	mm	0...0.1
	Preload	N	0.5
25_	Radial play	mm	0.015
26_	Max. axial load (dynamic)	N	0.5
27_	Max. force for press fits (static)	N	8.8
	(static, shaft supported)	N	120
28_	Max. radial load [mm from flange]	N	1.5 [5]

### Mechanical data sleeve bearings

23_	Max. speed	rpm	12000
24_	Axial play	mm	0...0.15
	Preload	N	0
25_	Radial play	mm	0.015
26_	Max. axial load (dynamic)	N	0.1
27_	Max. force for press fits (static)	N	30
	(static, shaft supported)	N	120
28_	Max. radial load [mm from flange]	N	0.8 [5]

### maxon Modular System

<b>maxon gear</b>	Stages	<b>maxon sensor</b>	<b>maxon motor control</b>
64_GPX 12 A	1-2	82_ENX 10 EASY	378_ESCON Module 24/2
60_GPX 14 A, C	3-4	82_ENX 10 QUAD	378_ESCON 36/2 DC
61_GPX 14 LN, LZ	3-4		386_EPOS2 24/2 (DC/EC)
			386_EPOS2 Module 36/2

### Other specifications

29_	Number of pole pairs		1
30_	Number of commutator segments		7
31_	Weight of motor	g	16
32_	Typical noise level	dBA	44

### Configuration

Bearing: Sleeve bearings/ball bearings preloaded  
 Commutation: Precious metal brushes with or without CLL  
 Flange front/back: Standard flange/Flange with thread holes/no flange  
 Shaft front/back: Length  
 Electric connection: Terminals or cable/cable length/connector type

[xdrives.maxonmotor.com](http://xdrives.maxonmotor.com)

# DCX 14 L Precious Metal Brushes

## DC motor Ø14 mm



3/5 W 6.3 mNm 8680 rpm

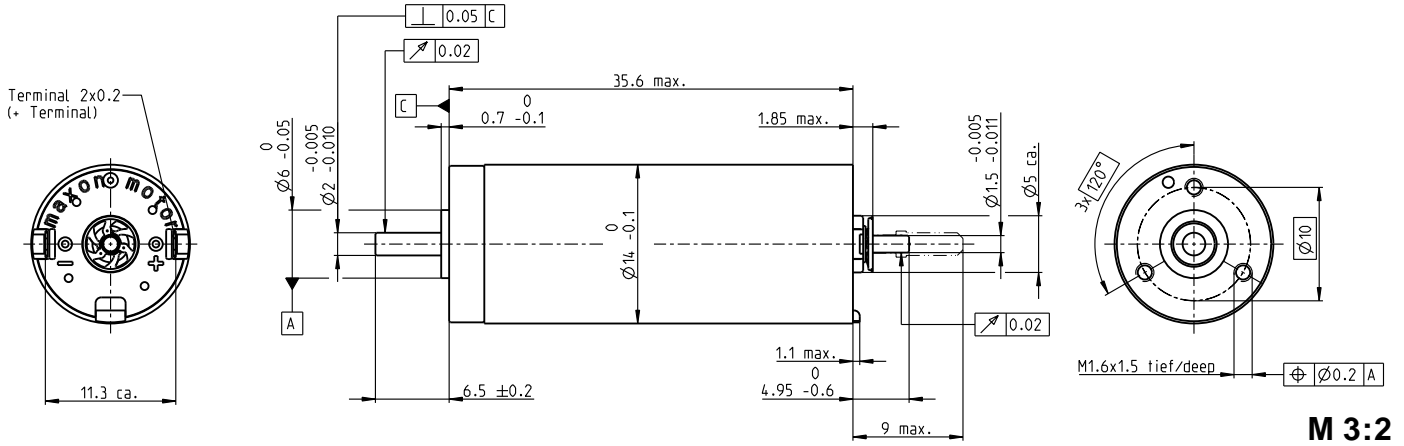

M 3:2

### Motor Data

1_	Nominal voltage	V	3	4.5	6	9	12	18	24
2_	No load speed	rpm	7720	7730	7730	7740	7740	7720	7730
3_	No load current	mA	76.3	50.9	38.2	25.5	19.1	12.7	9.55
4_	Nominal speed	rpm	5770	5170	5150	5210	5220	5060	5160
5_	Nominal torque (max. continuous torque)	mNm	4.11	6.25	6.19	6.33	6.34	5.96	6.2
6_	Nominal current (max. continuous current)	A	1.2	1.19	0.884	0.602	0.452	0.284	0.221
7_	Stall torque	mNm	16.5	19.1	18.8	19.6	19.7	17.5	18.9
8_	Stall current	A	4.52	3.49	2.57	1.79	1.35	0.799	0.647
9_	Max. efficiency	%	75.6	77.3	77.2	77.7	77.7	76.5	77.3
10_	Terminal resistance	Ω	0.664	1.29	2.33	5.02	8.9	22.5	37.1
11_	Terminal inductance	mH	0.0252	0.0567	0.101	0.227	0.403	0.908	1.61
12_	Torque constant	mNm/A	3.65	5.47	7.3	10.9	14.6	21.9	29.2
13_	Speed constant	rpm/V	2620	1740	1310	872	654	436	327
14_	Speed/torque gradient	rpm/mNm	476	411	418	400	399	449	415
15_	Mechanical time constant	ms	4.14	4.06	4.05	4.04	4.05	4.1	4.09
16_	Rotor inertia	gcm <sup>2</sup>	0.831	0.942	0.926	0.966	0.97	0.872	0.939

### Thermal data

17_	Thermal resistance housing-ambient	K/W	22.2
18_	Thermal resistance winding-housing	K/W	8.63
19_	Thermal time constant winding	s	10.3
20_	Thermal time constant motor	s	226
21_	Ambient temperature ball bearings	°C	-30...+85
21_	Ambient temperature sleeve bearings	°C	-30...+85
22_	Max. winding temperature	°C	100

### Operating Range

n [rpm] Winding 9 V

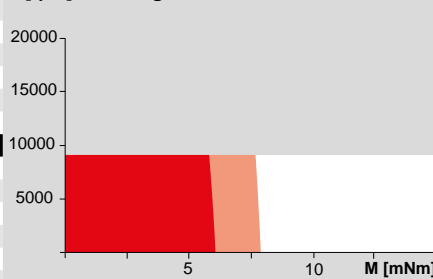

■ Continuous operation  
 ■ Continuous operation with reduced thermal resistance  $R_{th2}$  50%  
 □ Intermittent operation

### Mechanical data ball bearings

23_	Max. speed	rpm	8680
24_	Axial play	mm	0...0.1
	Preload	N	0.8
25_	Radial play	mm	0.015
26_	Max. axial load (dynamic)	N	0.8
27_	Max. force for press fits (static)	N	18
	(static, shaft supported)	N	300
28_	Max. radial load [mm from flange]	N	10 [5]

### Mechanical data sleeve bearings

23_	Max. speed	rpm	8680
24_	Axial play	mm	0...0.1
	Preload	N	0
25_	Radial play	mm	0.015
26_	Max. axial load (dynamic)	N	0.1
27_	Max. force for press fits (static)	N	60
	(static, shaft supported)	N	300
28_	Max. radial load [mm from flange]	N	2 [5]

### maxon Modular System

<b>maxon gear</b>	Stages	<b>maxon sensor</b>	<b>maxon motor control</b>
60_GPX 14 A, C	1-2	82_ENX 10 EASY	378_ESCON Module 24/2
61_GPX 14 LN, LZ	1-2	82_ENX 10 QUAD	378_ESCON 36/2 DC
62_GPX 16 A, C	3-4		386_EPOS2 24/2 (DC/EC)
63_GPX 16 LN, LZ	3-4		386_EPOS2 Module 36/2
64_GPX 16 HP	4		393_EPOS3 70/10 EtherCAT
			396_MAXPOS 50/5

### Other specifications

29_	Number of pole pairs		1
30_	Number of commutator segments		7
31_	Weight of motor	g	26
32_	Typical noise level	dBA	44

### Configuration

Bearing: Ball bearings preloaded/sleeve bearings  
 Commutation: Precious metal brushes with CLL/graphite brushes  
 Flange front/back: Standard flange/configurable flange/no flange  
 Shaft front/back: Length/diameter/flat face  
 Electric connection: Terminals or cable/alignment of connection/cable length/connector type

xdrives.maxonmotor.com



# DCX 14 L Graphite Brushes

## DC motor Ø14 mm



6/10 W 6.9 mNm 17000 rpm

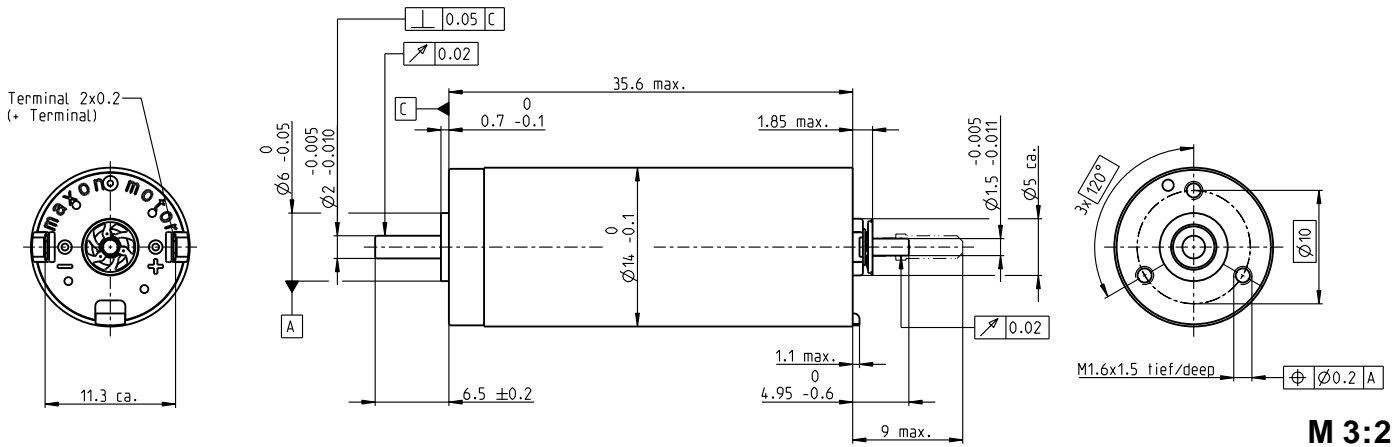

M 3:2

### Motor Data

1_ Nominal voltage	V	4.5	6	9	12	18	24
2_ No load speed	rpm	11600	10400	11700	10300	11600	10300
3_ No load current	mA	74.8	48	37.4	24	18.7	12
4_ Nominal speed	rpm	8470	7430	8760	7370	8760	7310
5_ Nominal torque (max. continuous torque)	mNm	6.34	6.92	6.85	6.87	6.91	6.62
6_ Nominal current (max. continuous current)	A	1.8	1.31	0.972	0.649	0.491	0.313
7_ Stall torque	mNm	23.5	24.8	27.8	24.7	28.5	22.9
8_ Stall current	A	6.45	4.53	3.8	2.26	1.95	1.05
9_ Max. efficiency	%	79.2	80.4	81.2	79.7	81	79.7
10_ Terminal resistance	Ω	0.698	1.33	2.37	5.31	9.21	22.9
11_ Terminal inductance	mH	0.0252	0.0567	0.101	0.227	0.403	0.908
12_ Torque constant	mNm/A	3.65	5.47	7.3	10.9	14.6	21.9
13_ Speed constant	rpm/V	2620	1740	1310	872	654	436
14_ Speed/torque gradient	rpm/mNm	500	422	424	423	413	456
15_ Mechanical time constant	ms	4.35	4.17	4.11	4.28	4.19	4.17
16_ Rotor inertia	gcm <sup>2</sup>	0.831	0.942	0.926	0.966	0.97	0.872

### Thermal data

17_ Thermal resistance housing-ambient	K/W	22.2
18_ Thermal resistance winding-housing	K/W	8.63
19_ Thermal time constant winding	s	10.3
20_ Thermal time constant motor	s	226
21_ Ambient temperature ball bearings	°C	-40...+100
21_ Ambient temperature sleeve bearings	°C	-30...+100
22_ Max. winding temperature	°C	125

### Operating Range

n [rpm] Winding 12 V

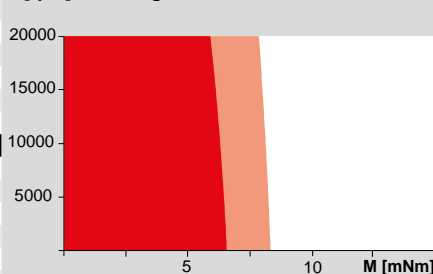

■ Continuous operation  
 ■ Continuous operation with reduced thermal resistance  $R_{th2}$  50%  
 □ Intermittent operation

### Mechanical data ball bearings

23_ Max. speed	rpm	17000
24_ Axial play	mm	0...0.1
Preload	N	0.8
25_ Radial play	mm	0.015
26_ Max. axial load (dynamic)	N	0.8
27_ Max. force for press fits (static) (static, shaft supported)	N	18
28_ Max. radial load [mm from flange]	N	300
		10 [5]

### Mechanical data sleeve bearings

23_ Max. speed	rpm	15000
24_ Axial play	mm	0...0.2
Preload	N	0
25_ Radial play	mm	0.015
26_ Max. axial load (dynamic)	N	0.1
27_ Max. force for press fits (static) (static, shaft supported)	N	60
28_ Max. radial load [mm from flange]	N	300
		2 [5]

### maxon Modular System

<b>maxon gear</b>	Stages	<b>maxon sensor</b>	<b>maxon motor control</b>
60_GPX 14 A, C	1-2	82_ENX 10 EASY	378_ESCON Module 24/2
61_GPX 14 LN, LZ	1-2	82_ENX 10 QUAD	378_ESCON 36/2 DC
62_GPX 16 A, C	3-4		386_EPOS2 24/2 (DC/EC)
63_GPX 16 LN, LZ	3-4		386_EPOS2 Module 36/2
64_GPX 16 HP	4		393_EPOS3 70/10 EtherCAT
			396_MAXPOS 50/5

### Other specifications

29_ Number of pole pairs		1
30_ Number of commutator segments		7
31_ Weight of motor	g	26
32_ Typical noise level	dBA	40

### Configuration

Bearing: Ball bearings preloaded/sleeve bearings  
 Commutation: Precious metal brushes with CLL/graphite brushes  
 Flange front/back: Standard flange/configurable flange/no flange  
 Shaft front/back: Length/diameter/flat face  
 Electric connection: Terminals or cable/alignment of connection/cable length/connector type

[xdrives.maxonmotor.com](http://xdrives.maxonmotor.com)

# DCX 16 S Precious Metal Brushes

## DC motor Ø16 mm

3/5 W 5.3 mNm 8680 rpm

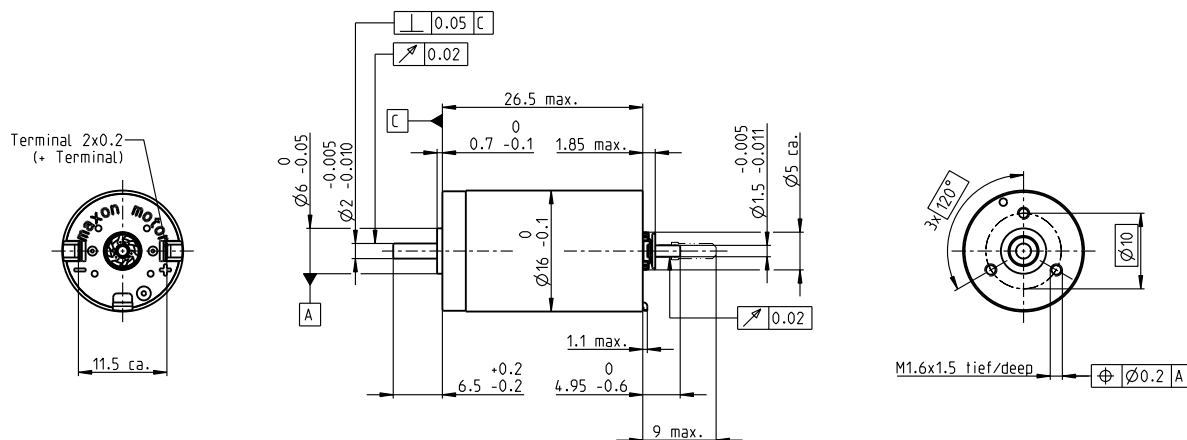

M 1:1

### Motor Data

		3	4.5	6	9	12	24
1_ Nominal voltage	V	3	4.5	6	9	12	24
2_ No load speed	rpm	6290	6290	6580	6290	6230	6220
3_ No load current	mA	56.0	37.3	29.6	18.7	13.8	6.91
4_ Nominal speed	rpm	3350	3300	3770	3280	3330	3210
5_ Nominal torque (max. continuous torque)	mNm	5.10	5.01	5.30	4.96	5.15	4.95
6_ Nominal current (max. continuous current)	A	1.20	0.782	0.648	0.388	0.298	0.143
7_ Stall torque	mNm	11.1	10.7	12.6	10.6	11.2	10.4
8_ Stall current	A	2.49	1.61	1.48	0.791	0.624	0.289
9_ Max. efficiency	%	73	72	74	72	73	72
10_ Terminal resistance	Ω	1.20	2.80	4.06	11.4	19.2	83.1
11_ Terminal inductance	mH	0.036	0.080	0.131	0.320	0.581	2.32
12_ Torque constant	mNm/A	4.45	6.67	8.53	13.3	18.0	36.0
13_ Speed constant	rpm/V	2150	1430	1120	715	531	265
14_ Speed/torque gradient	rpm/mNm	580	600	533	610	568	613
15_ Mechanical time constant	ms	6.09	6.09	6.05	6.13	6.11	6.17
16_ Rotor inertia	gcm <sup>2</sup>	1.00	0.97	1.08	0.959	1.03	0.960

### Thermal data

17_ Thermal resistance housing-ambient	K/W	23.5
18_ Thermal resistance winding-housing	K/W	9.9
19_ Thermal time constant winding	s	9.63
20_ Thermal time constant motor	s	227
21_ Ambient temperature ball bearings	°C	-30...+85
21_ Ambient temperature sleeve bearings	°C	-30...+85
22_ Max. winding temperature	°C	100

### Operating Range

n [rpm] Winding 12 V

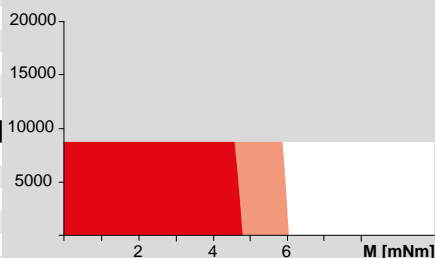

■ Continuous operation  
■ Continuous operation with reduced thermal resistance  $R_{th2}$  50%  
■ Intermittent operation

### Mechanical data ball bearings

23_ Max. speed	rpm	8680
24_ Axial play	mm	0...0.1
Preload	N	0.8
25_ Radial play	mm	0.015
26_ Max. axial load (dynamic)	N	0.8
27_ Max. force for press fits (static)	N	18
(static, shaft supported)	N	300
28_ Max. radial load [mm from flange]	N	10 [5]

### Mechanical data sleeve bearings

23_ Max. speed	rpm	8680
24_ Axial play	mm	0...0.2
Preload	N	0.8
25_ Radial play	mm	0.015
26_ Max. axial load (dynamic)	N	0.1
27_ Max. force for press fits (static)	N	18
(static, shaft supported)	N	300
28_ Max. radial load [mm from flange]	N	10 [5]

### maxon Modular System

maxon gear	Stages	maxon sensor	maxon motor control
62_GPX 16 A, C	1-2	82_ENX 10 EASY	378_ESCON Module 24/2
63_GPX 16 LN, LZ	1-2	82_ENX 10 QUAD	378_ESCON 36/2 DC
64_GPX 16 HP	2-3	83_ENX 16 EASY	386_EPOS2 24/2 (DC/EC)
66_GPX 19 A, C	3-4	84_ENX 16 EASY Abs.	386_EPOS2 Module 36/2
67_GPX 19 LN, LZ	3-4		393_EPOS3 70/10 EtherCAT
			396_MAXPOS 50/5

### Other specifications

29_ Number of pole pairs		1
30_ Number of commutator segments		7
31_ Weight of motor	g	26
32_ Typical noise level	dBA	40

### Configuration

Bearing: Ball bearings preloaded/sleeve bearings  
 Commutation: Precious metal brushes with CLL/graphite brushes  
 Flange front/back: Standard flange/configurable flange/no flange  
 Shaft front/back: Length/diameter/flat face  
 Electric connection: Terminals or cable/alignment of connection/cable length/connector type

xdrives.maxonmotor.com



# DCX 16 S Graphite Brushes

## DC motor Ø16 mm



5/10 W 5.7 mNm 17000 rpm

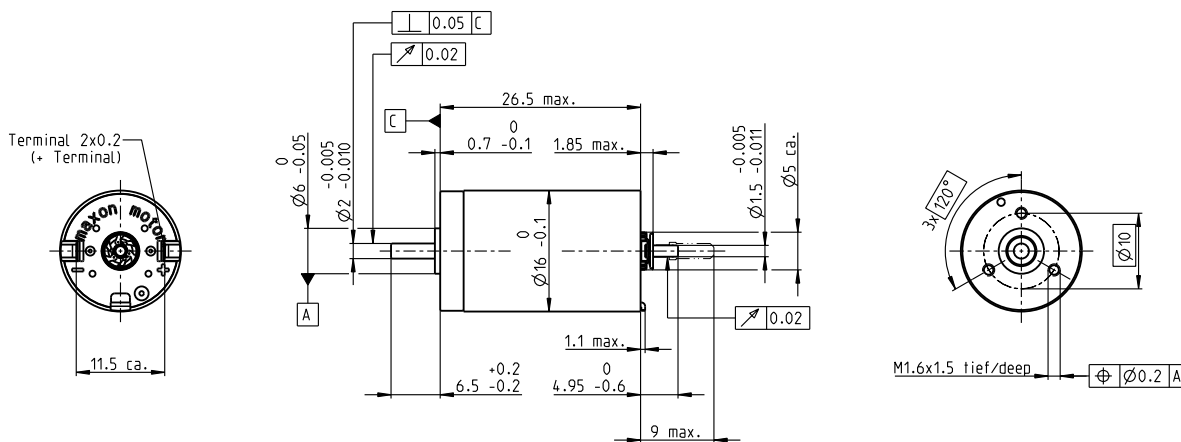

M 1:1

### Motor Data

1_	Nominal voltage	V	6	9	12	18	24	48
2_	No load speed	rpm	12700	12700	13200	12700	12700	12600
3_	No load current	mA	67.1	44.8	35.4	22.4	16.8	8.28
4_	Nominal speed	rpm	9400	9410	9850	9260	9430	9250
5_	Nominal torque (max. continuous torque)	mNm	5.41	5.37	5.36	5.21	5.43	5.32
6_	Nominal current (max. continuous current)	A	1.28	0.845	0.662	0.411	0.321	0.156
7_	Stall torque	mNm	21.3	21	22.6	20.1	21.7	20.6
8_	Stall current	A	4.79	3.15	2.65	1.51	1.22	0.572
9_	Max. efficiency	%	77	78	76	76	78	77
10_	Terminal resistance	Ω	1.25	2.85	4.53	12	19.7	83.9
11_	Terminal inductance	mH	0.036	0.080	0.131	0.320	0.569	2.32
12_	Torque constant	mNm/A	4.45	6.67	8.53	13.3	17.8	36.0
13_	Speed constant	rpm/V	2150	1430	1120	715	536	265
14_	Speed/torque gradient	rpm/mNm	605	612	594	641	592	620
15_	Mechanical time constant	ms	6.35	6.21	6.74	6.43	6.32	6.23
16_	Rotor inertia	gcm <sup>2</sup>	1.00	0.970	1.08	0.959	1.02	0.960

### Thermal data

17_	Thermal resistance housing-ambient	K/W	23.5
18_	Thermal resistance winding-housing	K/W	9.9
19_	Thermal time constant winding	s	9.63
20_	Thermal time constant motor	s	227
21_	Ambient temperature ball bearings	°C	-40...+100
21_	Ambient temperature sleeve bearings	°C	-30...+100
22_	Max. winding temperature	°C	125

### Operating Range

n [rpm] Winding 12 V

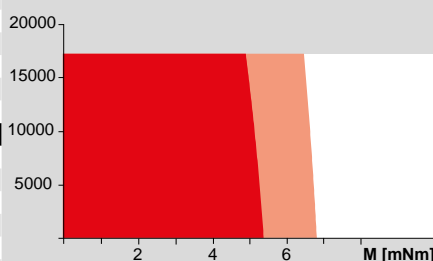

■ Continuous operation  
 ■ Continuous operation with reduced thermal resistance  $R_{th2}$  50%  
 □ Intermittent operation

### Mechanical data ball bearings

23_	Max. speed	rpm	17000
24_	Axial play	mm	0...0.1
	Preload	N	0.8
25_	Radial play	mm	0.015
26_	Max. axial load (dynamic)	N	0.8
27_	Max. force for press fits (static)	N	18
	(static, shaft supported)	N	300
28_	Max. radial load [mm from flange]	N	10 [5]

### Mechanical data sleeve bearings

23_	Max. speed	rpm	17000
24_	Axial play	mm	0...0.2
	Preload	N	0
25_	Radial play	mm	0.015
26_	Max. axial load (dynamic)	N	0.1
27_	Max. force for press fits (static)	N	60
	(static, shaft supported)	N	300
28_	Max. radial load [mm from flange]	N	2 [5]

### maxon Modular System

<b>maxon gear</b>	Stages	<b>maxon sensor</b>	<b>maxon motor control</b>
62_GPX 16 A, C	1-2	82_ENX 10 EASY	378_ESCON Module 24/2
63_GPX 16 LN, LZ	1-2	82_ENX 10 QUAD	378_ESCON 36/2 DC
64_GPX 16 HP	2-3	83_ENX 16 EASY	379_ESCON Module 50/5
66_GPX 19 A, C	3-4	84_ENX 16 EASY Abs.	379_ESCON 50/5
67_GPX 19 LN, LZ	3-4		386_EPOS2 24/2 (DC/EC)
			386_EPOS2 Module 36/2
			387_EPOS2 50/5
			393_EPOS3 70/10 EtherCAT
			396_MAXPOS 50/5

### Other specifications

29_	Number of pole pairs		1
30_	Number of commutator segments		7
31_	Weight of motor	g	26
32_	Typical noise level	dBA	38

### Configuration

Bearing: Ball bearings preloaded/sleeve bearings  
 Commutation: Precious metal brushes with CLL/graphite brushes  
 Flange front/back: Standard flange/configurable flange/no flange  
 Shaft front/back: Length/diameter/flat face  
 Electric connection: Terminals or cable/alignment of connection/cable length/connector type

xdrives.maxonmotor.com

# DCX 16 L Precious Metal Brushes

## DC motor Ø16 mm

5/10 W 11.5 mNm 8680 rpm

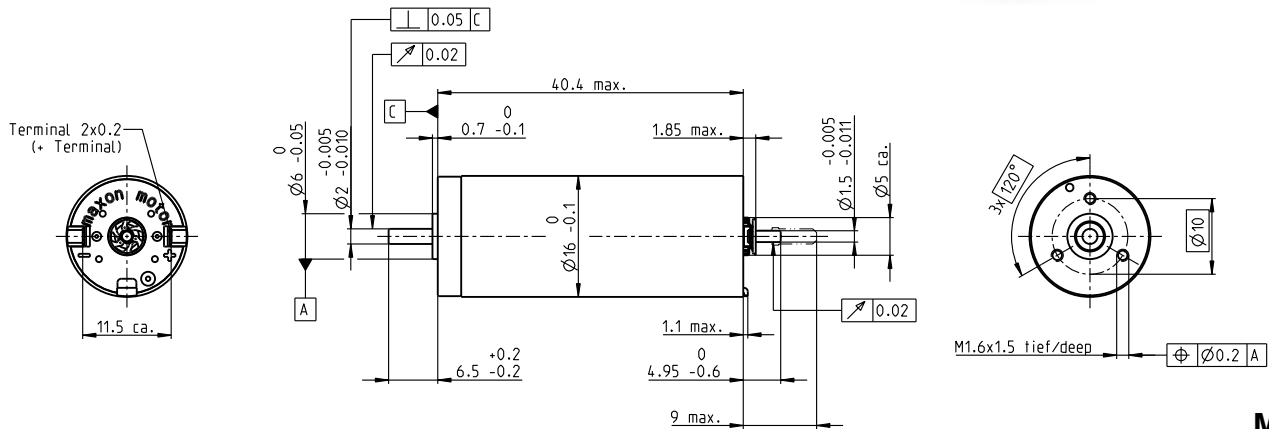

M 1:1

### Motor Data

	V	3	6	9	12	18	24
1_ Nominal voltage	V	3	6	9	12	18	24
2_ No load speed	rpm	6390	6620	6400	6400	6400	6560
3_ No load current	mA	66.8	34.9	22.3	16.7	11.1	8.62
4_ Nominal speed	rpm	5450	4920	4630	4500	4520	4640
5_ Nominal torque (max. continuous torque)	mNm	5.05	10.0	11.5	10.8	10.9	10.6
6_ Nominal current (max. continuous current)	A	1.20	1.20	0.887	0.622	0.419	0.315
7_ Stall torque	mNm	34.4	39.3	41.8	36.6	37.3	36.6
8_ Stall current	A	7.73	4.57	3.14	2.06	1.40	1.06
9_ Max. efficiency	%	82	83	84	83	83	83
10_ Terminal resistance	Ω	0.388	1.31	2.87	5.82	12.9	22.7
11_ Terminal inductance	mH	0.026	0.096	0.231	0.411	0.925	1.56
12_ Torque constant	mNm/A	4.44	8.59	13.3	17.8	26.7	34.7
13_ Speed constant	rpm/V	2150	1110	716	537	358	276
14_ Speed/torque gradient	rpm/mNm	188	170	154	176	173	181
15_ Mechanical time constant	ms	4.29	4.20	4.18	4.19	4.22	4.23
16_ Rotor inertia	gcm <sup>2</sup>	2.18	2.36	2.59	2.28	2.33	2.23

### Thermal data

17_ Thermal resistance housing-ambient	K/W	17.9
18_ Thermal resistance winding-housing	K/W	7.21
19_ Thermal time constant winding	s	21.5
20_ Thermal time constant motor	s	294
21_ Ambient temperature ball bearings	°C	-30...+85
21_ Ambient temperature sleeve bearings	°C	-30...+85
22_ Max. winding temperature	°C	100

### Operating Range

n [rpm] Winding 9 V

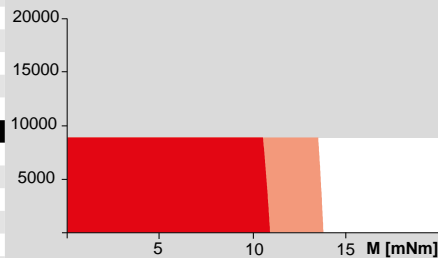

■ Continuous operation  
 ■ Continuous operation with reduced thermal resistance  $R_{th2}$  50%  
 ■ Intermittent operation

### Mechanical data ball bearings

23_ Max. speed	rpm	8680
24_ Axial play	mm	0...0.1
Preload	N	0.8
25_ Radial play	mm	0.015
26_ Max. axial load (dynamic)	N	0.8
27_ Max. force for press fits (static)	N	18
(static, shaft supported)	N	300
28_ Max. radial load [mm from flange]	N	10 [5]

### Mechanical data sleeve bearings

23_ Max. speed	rpm	8680
24_ Axial play	mm	0...0.1
Preload	N	0
25_ Radial play	mm	0.015
26_ Max. axial load (dynamic)	N	0.1
27_ Max. force for press fits (static)	N	60
(static, shaft supported)	N	300
28_ Max. radial load [mm from flange]	N	2 [5]

### maxon Modular System

maxon gear	Stages	maxon sensor	maxon motor control
62_GPX 16 A, C	1-2	82_ENX 10 EASY	378_ESCON Module 24/2
63_GPX 16 LN, LZ	1-2	82_ENX 10 QUAD	378_ESCON 36/2 DC
64_GPX 16 HP	2-3	83_ENX 16 EASY	386_EPOS2 24/2 (DC/EC)
66_GPX 19 A, C	3-4	84_ENX 16 EASY Abs.	386_EPOS2 Module 36/2
67_GPX 19 LN, LZ	3-4		390_EPOS2 P 24/5
			393_EPOS3 70/10 EtherCAT
			396_MAXPOS 50/5

### Other specifications

29_ Number of pole pairs		1
30_ Number of commutator segments		7
31_ Weight of motor	g	42
32_ Typical noise level	dBA	44

### Configuration

Bearing: Ball bearings preloaded/sleeve bearings  
 Commutation: Precious metal brushes with CLL/graphite brushes  
 Flange front/back: Standard flange/configurable flange/no flange  
 Shaft front/back: Length/diameter/flat face  
 Electric connection: Terminals or cable/alignment of connection/cable length/connector type

xdrives.maxonmotor.com



# DCX 16 L Graphite Brushes

## DC motor Ø16 mm

10/19 W 12.5 mNm 17000 rpm

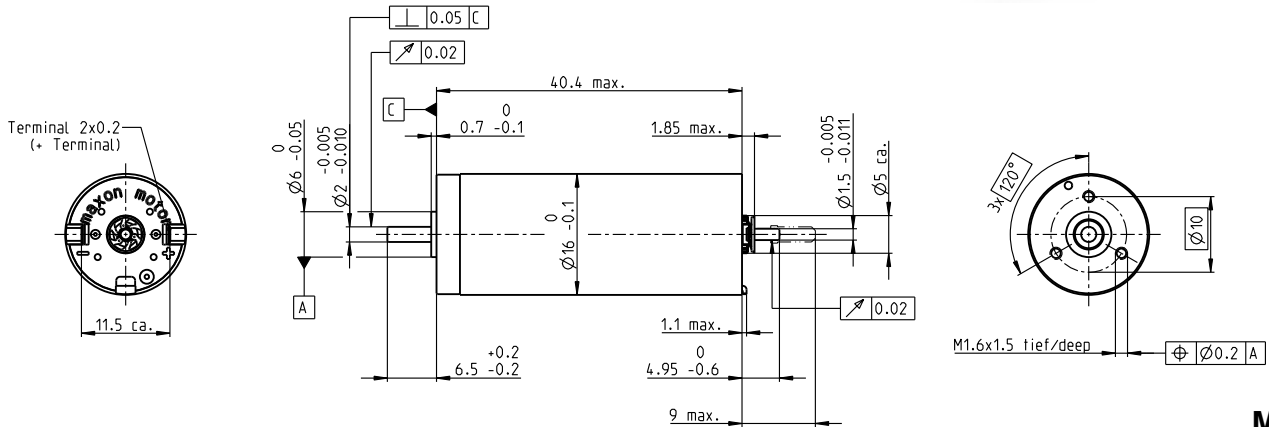

M 1:1

### Motor Data

1_ Nominal voltage	V	6	9	12	18	24	36
2_ No load speed	rpm	12800	13100	13200	12800	12800	12800
3_ No load current	mA	79.3	54.8	41.6	26.4	19.8	13.2
4_ Nominal speed	rpm	11000	11000	10700	10600	10600	10700
5_ Nominal torque (max. continuous torque)	mNm	8.56	11.7	10.3	11.6	11.2	11.6
6_ Nominal current (max. continuous current)	A	2.00	1.85	1.24	0.894	0.649	0.446
7_ Stall torque	mNm	61.9	74.3	63.3	74.5	68.5	72.1
8_ Stall current	A	13.9	11.4	7.37	5.59	3.86	2.70
9_ Max. efficiency	%	85	86	83	85	85	86
10_ Terminal resistance	Ω	0.43	0.79	1.63	3.22	6.22	13.3
11_ Terminal inductance	mH	0.026	0.055	0.096	0.231	0.411	0.925
12_ Torque constant	mNm/A	4.44	6.52	8.59	13.3	17.8	26.7
13_ Speed constant	rpm/V	2150	1470	1110	716	537	358
14_ Speed/torque gradient	rpm/mNm	208	178	211	173	188	179
15_ Mechanical time constant	ms	4.76	4.46	5.21	4.70	4.48	4.37
16_ Rotor inertia	gcm <sup>2</sup>	2.18	2.40	2.36	2.59	2.28	2.33

### Thermal data

17_ Thermal resistance housing-ambient	K/W	17.9
18_ Thermal resistance winding-housing	K/W	7.21
19_ Thermal time constant winding	s	21.5
20_ Thermal time constant motor	s	294
21_ Ambient temperature ball bearings	°C	-40...+100
21_ Ambient temperature sleeve bearings	°C	-30...+100
22_ Max. winding temperature	°C	125

### Operating Range

n [rpm] Winding 12 V

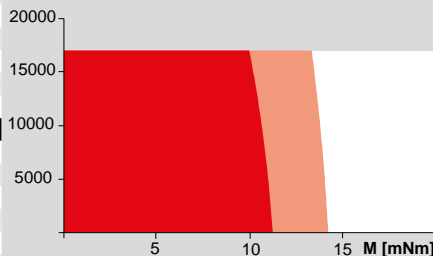

■ Continuous operation  
■ Continuous operation with reduced thermal resistance  $R_{th2}$  50%  
■ Intermittent operation

### Mechanical data ball bearings

23_ Max. speed	rpm	17000
24_ Axial play	mm	0...0.1
Preload	N	0.8
25_ Radial play	mm	0.015
26_ Max. axial load (dynamic)	N	0.8
27_ Max. force for press fits (static) (static, shaft supported)	N	300
28_ Max. radial load [mm from flange]	N	10 [5]

### Mechanical data sleeve bearings

23_ Max. speed	rpm	15000
24_ Axial play	mm	0...0.1
Preload	N	0
25_ Radial play	mm	0.015
26_ Max. axial load (dynamic)	N	0.1
27_ Max. force for press fits (static) (static, shaft supported)	N	300
28_ Max. radial load [mm from flange]	N	2 [5]

### maxon Modular System

<b>maxon gear</b>	Stages	<b>maxon sensor</b>	<b>maxon motor control</b>
62_GPX 16 A, C	1-2	82_ENX 10 EASY	378_ESCON Module 24/2
63_GPX 16 LN, LZ	1-2	82_ENX 10 QUAD	378_ESCON 36/2 DC
64_GPX 16 HP	2-3	83_ENX 16 EASY	386_EPOS2 24/2 (DC/EC)
66_GPX 19 A, C	3-4	84_ENX 16 EASY Abs.	386_EPOS2 Module 36/2
67_GPX 19 LN, LZ	3-4		390_EPOS2 P 24/5
			393_EPOS3 70/10 EtherCAT
			396_MAXPOS 50/5

### Other specifications

29_ Number of pole pairs		1
30_ Number of commutator segments		7
31_ Weight of motor	g	42
32_ Typical noise level	dBA	40

### Configuration

Bearing: Ball bearings preloaded/sleeve bearings  
 Commutation: Precious metal brushes with CLL/graphite brushes  
 Flange front/back: Standard flange/configurable flange/no flange  
 Shaft front/back: Length/diameter/flat face  
 Electric connection: Terminals or cable/alignment of connection/cable length/connector type

[xdrives.maxonmotor.com](http://xdrives.maxonmotor.com)

# DCX 19 S Precious Metal Brushes

## DC motor Ø19 mm

**NEW**

5/8 W 11.1 mNm 7500 rpm

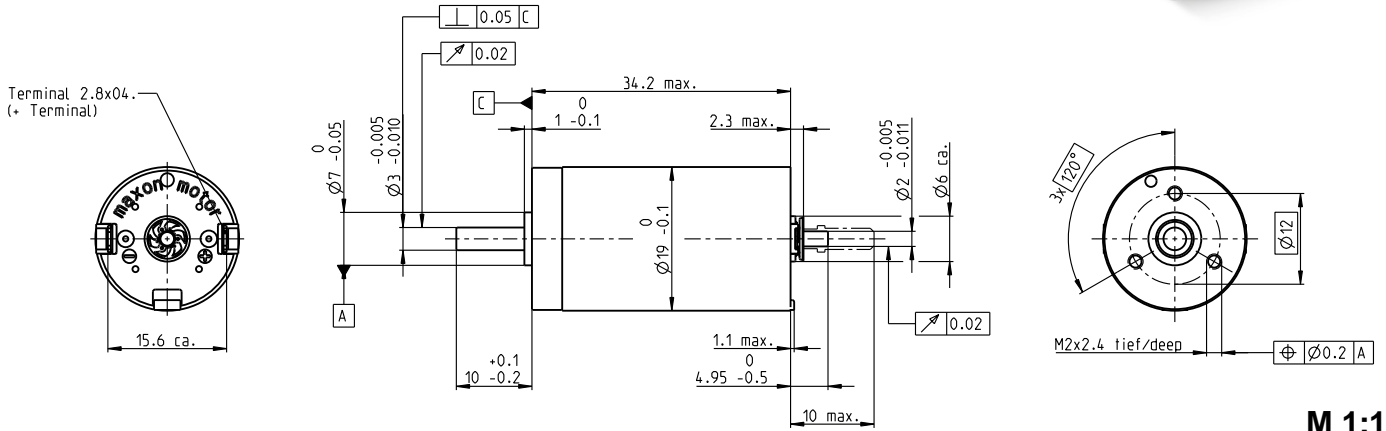

**M 1:1**

**Motor Data**

1_ Nominal voltage	V	4.5	6	9	12	18	24
2_ No load speed	rpm	6440	6350	6260	6360	6360	6350
3_ No load current	mA	72	53	34.6	26.5	17.7	13.2
4_ Nominal speed	rpm	5080	4540	4350	4490	4490	4480
5_ Nominal torque (max. continuous torque)	mNm	7.46	10.3	10.8	11.0	11.0	10.9
6_ Nominal current (max. continuous current)	A	1.20	1.20	0.829	0.643	0.428	0.319
7_ Stall torque	mNm	35.7	36.3	35.8	38.0	37.8	37.5
8_ Stall current	A	5.42	4.07	2.64	2.13	1.41	1.05
9_ Max. efficiency	%	78	79	79	79	79	79
10_ Terminal resistance	Ω	0.831	1.47	3.40	5.63	12.7	22.8
11_ Terminal inductance	mH	0.045	0.082	0.191	0.329	0.740	1.320
12_ Torque constant	mNm/A	6.58	8.90	13.5	17.8	26.7	35.6
13_ Speed constant	rpm/V	1450	1070	705	536	358	268
14_ Speed/torque gradient	rpm/mNm	183	177	177	170	170	172
15_ Mechanical time constant	ms	5.12	4.99	4.92	4.89	4.89	4.90
16_ Rotor inertia	gcm <sup>2</sup>	2.67	2.68	2.65	2.75	2.74	2.72

**Thermal data**

17_ Thermal resistance housing-ambient	K/W	17.6
18_ Thermal resistance winding-housing	K/W	6.5
19_ Thermal time constant winding	s	11.6
20_ Thermal time constant motor	s	312
21_ Ambient temperature ball bearings	°C	-30...+85
21_ Ambient temperature sleeve bearings	°C	-30...+85
22_ Max. winding temperature	°C	100

**Operating Range**

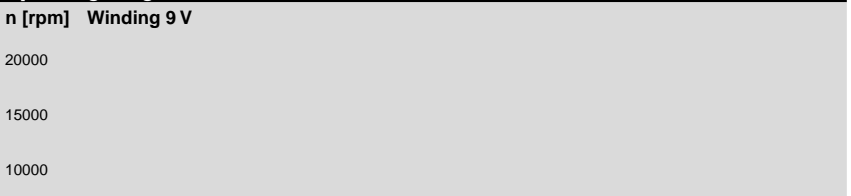

**Mechanical data ball bearings**

23_ Max. speed	rpm	7500
24_ Axial play	mm	0...0.1
Preload	N	2.5
25_ Radial play	mm	0.02
26_ Max. axial load (dynamic)	N	2.5
27_ Max. force for press fits (static)	N	30
(static, shaft supported)	N	440
28_ Max. radial load [mm from flange]	N	16 [5]

**Mechanical data sleeve bearings**

23_ Max. speed	rpm	7500
24_ Axial play	mm	0...0.2
Preload	N	0
25_ Radial play	mm	0.02
26_ Max. axial load (dynamic)	N	0.1
27_ Max. force for press fits (static)	N	80
(static, shaft supported)	N	440
28_ Max. radial load [mm from flange]	N	3 [5]

**maxon Modular System**

<b>maxon gear</b>	Stages	<b>maxon sensor</b>	<b>maxon motor control</b>
66_GPX 19 A, C	1-2	102_ENX 10 QUAD	378_ESCON Module 24/2
67_GPX 19 LN, LZ	1-2	103_ENX 16 EASY	378_ESCON 36/2 DC
68_GPX 22 A, C	3-4	104_ENX 16 EASY Abs.	386_EPOS2 24/2 (DC/EC)
69_GPX 22 LN, LZ	3-4		386_EPOS2 Module 36/2
70_GPX 22 HP	4		390_EPOS2 P 24/5
			393_EPOS3 70/10 EtherCAT
			396_MAXPOS 50/5

**Other specifications**

29_ Number of pole pairs		1
30_ Number of commutator segments		9
31_ Weight of motor	g	50
32_ Typical noise level	dBA	48

**Configuration**

Bearing: Ball bearings preloaded/sleeve bearings  
 Commutation: Precious metal brushes with CLL/graphite brushes  
 Flange front/back: Standard flange/configurable flange/no flange  
 Shaft front/back: Length/diameter/flat face  
 Electric connection: Terminals or cable/alignment of connection/cable length/connector type

[xdrives.maxonmotor.com](http://xdrives.maxonmotor.com)

# DCX 19 S Graphite Brushes

## DC motor Ø19 mm

**NEW**

11/17 W 11.3 mNm 18000 rpm

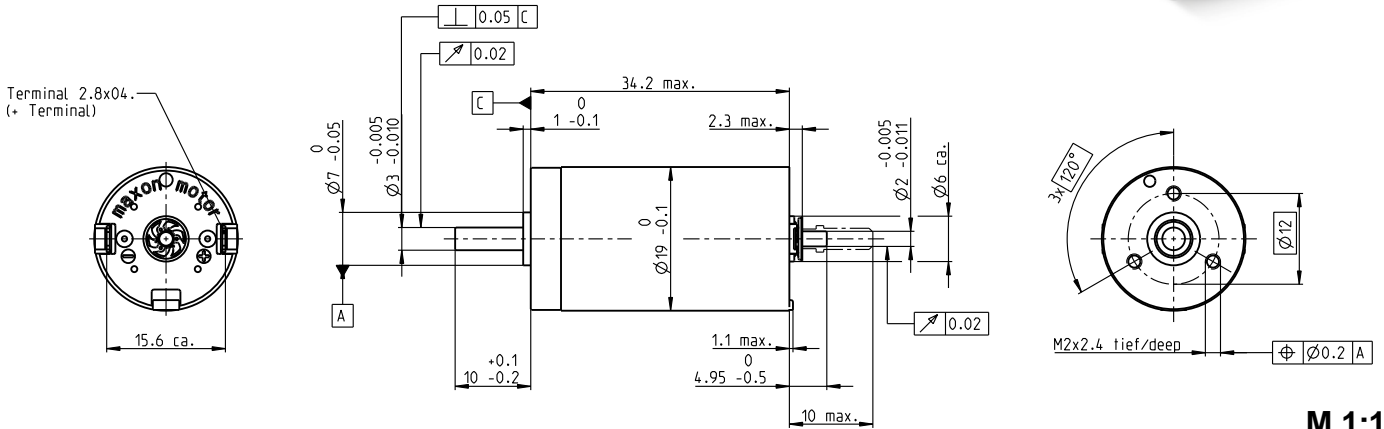

M 1:1

### Motor Data

1_	Nominal voltage	V	9	12	18	24	36	48
2_	No load speed	rpm	12900	12800	12600	12700	12700	12700
3_	No load current	mA	102	75	48.9	37.4	25	18.7
4_	Nominal speed	rpm	10900	10800	10600	10600	10700	10700
5_	Nominal torque (max. continuous torque)	mNm	11.3	11.4	11.4	11.1	11.3	11.3
6_	Nominal current (max. continuous current)	A	1.81	1.35	0.884	0.657	0.445	0.335
7_	Stall torque	mNm	73.8	73.9	72.2	73.2	73.9	73.8
8_	Stall current	A	11.2	8.30	5.33	4.11	2.77	2.07
9_	Max. efficiency	%	82	82	82	81	82	82
10_	Terminal resistance	Ω	0.802	1.45	3.38	5.84	13.0	23.2
11_	Terminal inductance	mH	0.045	0.082	0.191	0.329	0.740	1.320
12_	Torque constant	mNm/A	6.58	8.90	13.5	17.8	26.7	35.6
13_	Speed constant	rpm/V	1450	1070	705	536	358	268
14_	Speed/torque gradient	rpm/mNm	177	174	176	176	174	174
15_	Mechanical time constant	ms	4.94	4.90	4.88	5.07	5.00	4.97
16_	Rotor inertia	gcm <sup>2</sup>	2.67	2.68	2.65	2.75	2.74	2.72

### Thermal data

17_	Thermal resistance housing-ambient	K/W	17.6
18_	Thermal resistance winding-housing	K/W	6.5
19_	Thermal time constant winding	s	11.6
20_	Thermal time constant motor	s	312
21_	Ambient temperature ball bearings	°C	-40...+100
21_	Ambient temperature sleeve bearings	°C	-30...+100
22_	Max. winding temperature	°C	125

### Operating Range

n [rpm] Winding 18 V

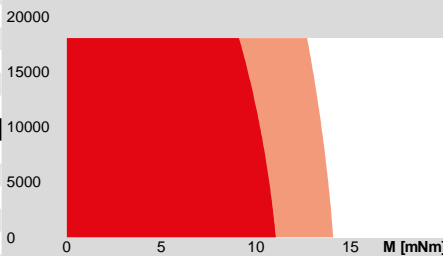

■ Continuous operation  
■ Continuous operation with reduced thermal resistance  $R_{th2}$  50%  
■ Intermittent operation

### Mechanical data ball bearings

23_	Max. speed	rpm	18000
24_	Axial play	mm	0...0.1
	Preload	N	2.5
25_	Radial play	mm	0.02
26_	Max. axial load (dynamic)	N	2.5
27_	Max. force for press fits (static)	N	30
	(static, shaft supported)	N	440
28_	Max. radial load [mm from flange]	N	16 [5]

### Mechanical data sleeve bearings

23_	Max. speed	rpm	13500
24_	Axial play	mm	0...0.2
	Preload	N	0
25_	Radial play	mm	0.02
26_	Max. axial load (dynamic)	N	0.1
27_	Max. force for press fits (static)	N	80
	(static, shaft supported)	N	440
28_	Max. radial load [mm from flange]	N	3 [5]

### Other specifications

29_	Number of pole pairs		1
30_	Number of commutator segments		9
31_	Weight of motor	g	50
32_	Typical noise level	dBA	40

### maxon Modular System

<b>maxon gear</b>	Stages	<b>maxon sensor</b>	<b>maxon motor control</b>
66_GPX 19 A, C	1-2	102_ENX 10 QUAD	378_ESCON Module 24/2
67_GPX 19 LN, LZ	1-2	103_ENX 16 EASY	378_ESCON 36/2 DC
68_GPX 22 A, C	3-4	104_ENX 16 EASY Abs.	379_ESCON Module 50/5
69_GPX 22 LN, LZ	3-4		379_ESCON 50/5
70_GPX 22 HP	4		386_EPOS2 24/2 (DC/EC)
			386_EPOS2 Module 36/2
			387_EPOS2 50/5
			390_EPOS2 P 24/5
			393_EPOS3 70/10 EtherCAT
			396_MAXPOS 50/5

### Configuration

Bearing: Ball bearings preloaded/sleeve bearings  
 Commutation: Precious metal brushes with CLL/graphite brushes  
 Flange front/back: Standard flange/configurable flange/no flange  
 Shaft front/back: Length/diameter/flat face  
 Electric connection: Terminals or cable/alignment of connection/cable length/connector type

[xdrives.maxonmotor.com](http://xdrives.maxonmotor.com)



# DCX 22 S Precious Metal Brushes

## DC motor Ø22 mm



6/10 W 14.5 mNm 7160 rpm

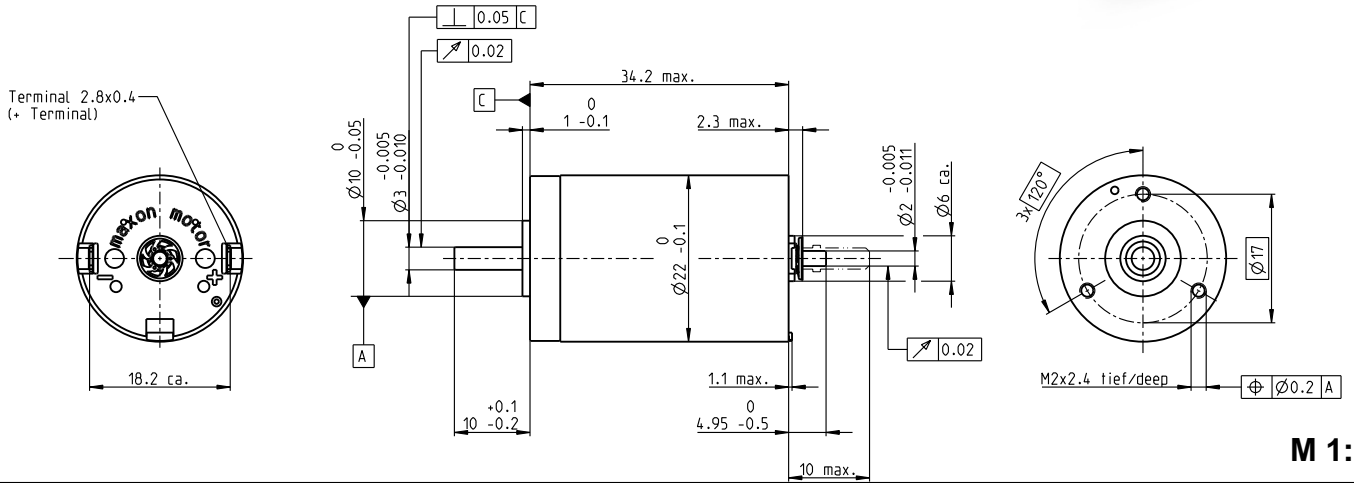

M 1:1

### Motor Data

1_ Nominal voltage	V	6	12	18	24	36	48
2_ No load speed	rpm	6200	6200	6110	6340	6550	5890
3_ No load current	mA	39.2	19.6	12.8	10.1	7.09	4.55
4_ Nominal speed	rpm	4960	4670	4560	4700	4940	4240
5_ Nominal torque (max. continuous torque)	mNm	10.7	14.7	14.5	13.6	13.8	13.6
6_ Nominal current (max. continuous current)	A	1.20	0.817	0.531	0.388	0.272	0.180
7_ Stall torque	mNm	53.7	59.7	57.5	52.7	56.5	48.6
8_ Stall current	A	5.85	3.25	2.06	1.47	1.08	0.63
9_ Max. efficiency	%	84	85	85	84	85	84
10_ Terminal resistance	Ω	1.02	3.69	8.75	16.3	33.3	76.2
11_ Terminal inductance	mH	0.058	0.231	0.535	0.881	1.86	4.08
12_ Torque constant	mNm/A	9.18	18.4	28.0	35.9	52.2	77.2
13_ Speed constant	rpm/V	1040	520	342	266	183	124
14_ Speed/torque gradient	rpm/mNm	116	104	107	121	117	122
15_ Mechanical time constant	ms	6.14	6.07	6.09	5.93	6.15	6.19
16_ Rotor inertia	gcm <sup>2</sup>	5.05	5.55	5.44	4.67	5.03	4.84

### Thermal data

17_ Thermal resistance housing-ambient	K/W	16
18_ Thermal resistance winding-housing	K/W	7
19_ Thermal time constant winding	s	20
20_ Thermal time constant motor	s	528
21_ Ambient temperature ball bearings	°C	-30...85
21_ Ambient temperature sleeve bearings	°C	-30...85
22_ Max. winding temperature	°C	100

### Operating Range

n [rpm] Winding 18 V

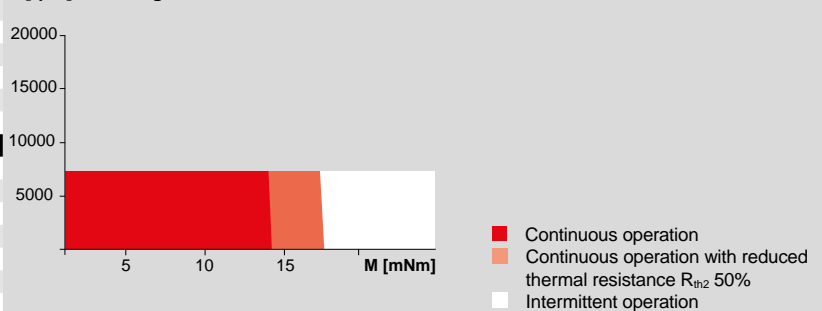

### Mechanical data ball bearings

23_ Max. speed	rpm	7160
24_ Axial play	mm	0...0.1
Preload	N	2.5
25_ Radial play	mm	0.02
26_ Max. axial load (dynamic)	N	2.5
27_ Max. force for press fits (static) (static, shaft supported)	N	30
28_ Max. radial load [mm from flange]	N	16 [5]

### Mechanical data sleeve bearings

23_ Max. speed	rpm	7160
24_ Axial play	mm	0...0.2
Preload	N	0
25_ Radial play	mm	0.02
26_ Max. axial load (dynamic)	N	0.1
27_ Max. force for press fits (static) (static, shaft supported)	N	80
28_ Max. radial load [mm from flange]	N	3 [5]

### Other specifications

29_ Number of pole pairs		1
30_ Number of commutator segments		9
31_ Weight of motor	g	66
32_ Typical noise level	dB(A)	48

### maxon Modular System

<b>maxon gear</b>	Stages	<b>maxon sensor</b>	<b>maxon motor control</b>
68_GPX 22 A, C	1-2	82_ENX 10 QUAD	378_ESCON Module 24/2
69_GPX 22 LN, LZ	1-2	83_ENX 16 EASY	378_ESCON 36/2 DC
70_GPX 22 HP	2-3	84_ENX 16 EASY Abs.	379_ESCON 50/5
71_GPX 26 A, C	3	359_ENC SCH16F	379_ESCON Module 50/5
72_GPX 26 LN, LZ	3	367_ENC 30 HEDL 5540	386_EPOS2 24/2 (DC/EC)
			386_EPOS2 Module 36/2
			387_EPOS2 50/5
			390_EPOS2 P 24/5
			393_EPOS3 70/10 EtherCAT
			396_MAXPOS 50/5

### Configuration

Bearing: Ball bearings preloaded/sleeve bearings  
 Commutation: Precious metal brushes with or without CLL/graphite brushes/EMI filter  
 Flange front/back: Standard flange/configurable flange/no flange  
 Shaft front/back: Length/diameter/flat face  
 Electric connection: Terminals or cable/alignment of connection/cable length/connector type

xdrives.maxonmotor.com

# DCX 22 S Graphite Brushes

## DC motor Ø22 mm



14/24 W 15.3 mNm 18000 rpm

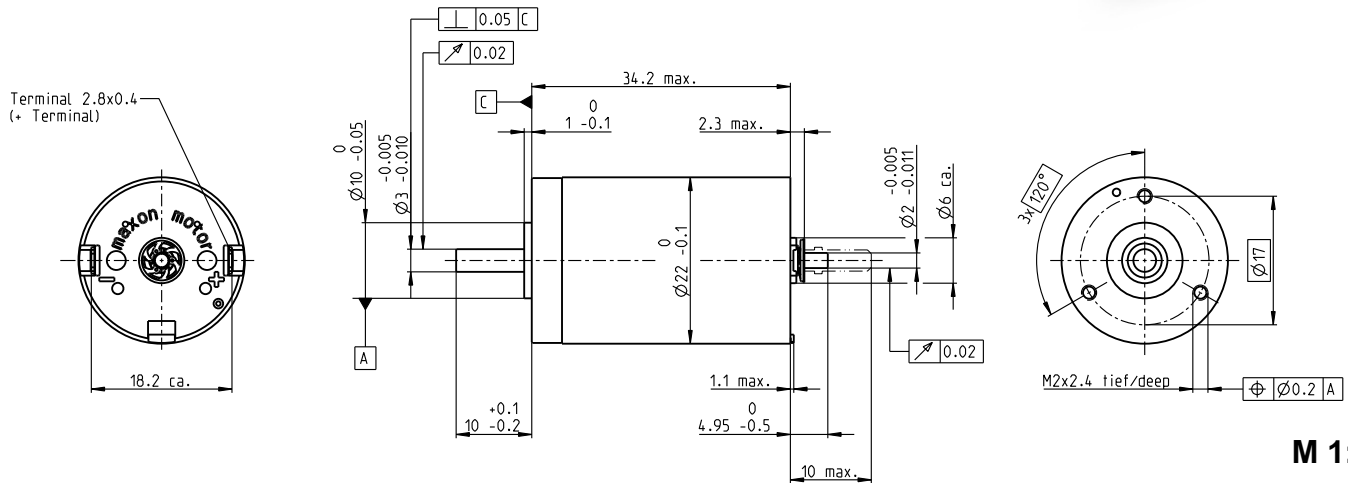

M 1:1

### Motor Data

1_	Nominal voltage	V	6	12	18	24	36	48
2_	No load speed	rpm	11400	12400	12400	12400	12200	12700
3_	No load current	mA	126	71.7	47.8	35.9	23.4	18.5
4_	Nominal speed	rpm	9700	10700	10800	10800	10500	10900
5_	Nominal torque (max. continuous torque)	mNm	14.4	14.6	14.9	15.3	14.8	14.0
6_	Nominal current (max. continuous current)	A	3.00	1.65	1.12	0.869	0.552	0.406
7_	Stall torque	mNm	101	108	112	120	113	104
8_	Stall current	A	20.2	11.8	8.15	6.51	4.03	2.90
9_	Max. efficiency	%	85	85	85	86	85	84
10_	Terminal resistance	Ω	0.297	1.02	2.21	3.69	8.94	16.6
11_	Terminal inductance	mH	0.017	0.058	0.130	0.231	0.535	0.881
12_	Torque constant	mNm/A	5.01	9.18	13.8	18.4	28.0	35.9
13_	Speed constant	rpm/V	1910	1040	693	520	342	266
14_	Speed/torque gradient	rpm/mNm	113	116	111	104	109	123
15_	Mechanical time constant	ms	6.23	6.12	6.08	6.07	6.22	6.01
16_	Rotor inertia	gcm <sup>2</sup>	5.27	5.05	5.22	5.55	5.44	4.67

### Thermal data

17_	Thermal resistance housing-ambient	K/W	16
18_	Thermal resistance winding-housing	K/W	7
19_	Thermal time constant winding	s	20
20_	Thermal time constant motor	s	528
21_	Ambient temperature ball bearings	°C	-40...+100
21_	Ambient temperature sleeve bearings	°C	-30...+100
22_	Max. winding temperature	°C	125

### Operating Range

n [rpm] Winding 18 V

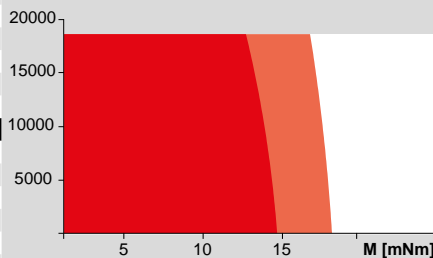

■ Continuous operation  
■ Continuous operation with reduced thermal resistance  $R_{th2}$  50%  
■ Intermittent operation

### Mechanical data ball bearings

23_	Max. speed	rpm	18000
24_	Axial play	mm	0...0.1
	Preload	N	2.5
25_	Radial play	mm	0.02
26_	Max. axial load (dynamic)	N	2.5
27_	Max. force for press fits (static)	N	30
	(static, shaft supported)	N	440
28_	Max. radial load [mm from flange]	N	16 [5]

### Mechanical data sleeve bearings

23_	Max. speed	rpm	18000
24_	Axial play	mm	0...0.2
	Preload	N	0
25_	Radial play	mm	0.02
26_	Max. axial load (dynamic)	N	0.1
27_	Max. force for press fits (static)	N	80
	(static, shaft supported)	N	440
28_	Max. radial load [mm from flange]	N	3 [5]

### Other specifications

29_	Number of pole pairs		1
30_	Number of commutator segments		9
31_	Weight of motor	g	66
32_	Typical noise level	dB(A)	41

### maxon Modular System

<b>maxon gear</b>	Stages	<b>maxon sensor</b>	<b>maxon motor control</b>
68_GPX 22 A, C	1-2	82_ENX 10 QUAD	378_ESCON Module 24/2
69_GPX 22 LN, LZ	1-2	83_ENX 16 EASY	378_ESCON 36/2 DC
70_GPX 22 HP	2-3	84_ENX 16 EASY Abs.	379_ESCON 50/5
71_GPX 26 A, C	3	359_ENC SCH16F	379_ESCON Module 50/5
72_GPX 26 LN, LZ	3	367_ENC 30 HEDL 5540	386_EPOS2 24/2 (DC/EC)
			386_EPOS2 Module 36/2
			387_EPOS2 24/5
			387_EPOS2 50/5
			390_EPOS2 P 24/5
			393_EPOS3 70/10 EtherCAT
			396_MAXPOS 50/5

### Configuration

Bearing: Ball bearings preloaded/sleeve bearings  
 Commutation: Precious metal brushes with or without CLL/graphite brushes/EMI filter  
 Flange front/back: Standard flange/configurable flange/no flange  
 Shaft front/back: Length/diameter/flat face  
 Electric connection: Terminals or cable/alignment of connection/cable length/connector type

[xdrives.maxonmotor.com](http://xdrives.maxonmotor.com)

# DCX 22 L Precious Metal Brushes

## DC motor Ø22 mm

11/20 W 29.8 mNm 7160 rpm

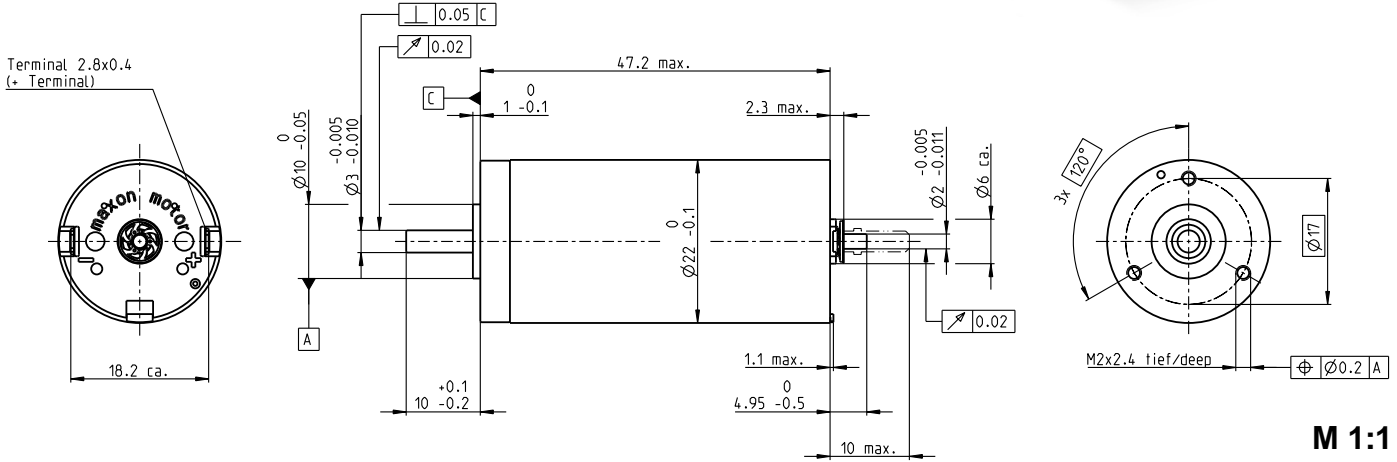

M 1:1

### Motor Data

1_ Nominal voltage	V	6	9	12	18	24	36	48
2_ No load speed	rpm	5870	5870	4980	5740	5060	6020	5220
3_ No load current	mA	51.0	34	20.0	16.4	10.2	8.82	5.36
4_ Nominal speed	rpm	5380	5210	4000	4780	4070	5040	4180
5_ Nominal torque (max. continuous torque)	mNm	14.1	21.4	29.5	29.8	29.2	29.2	27.8
6_ Nominal current (max. continuous current)	A	1.50	1.50	1.30	1.01	0.655	0.520	0.322
7_ Stall torque	mNm	170	191	150	178	150	180	140
8_ Stall current	A	17.5	13.1	6.54	5.97	3.31	3.16	1.60
9_ Max. efficiency	%	89	90	89	90	89	90	89
10_ Terminal resistance	Ω	0.343	0.687	1.84	3.01	7.25	11.4	29.9
11_ Terminal inductance	mH	0.035	0.078	0.192	0.326	0.746	1.19	2.80
12_ Torque constant	mNm/A	9.73	14.6	22.9	29.9	45.2	57.0	87.6
13_ Speed constant	rpm/V	981	654	416	320	211	168	109
14_ Speed/torque gradient	rpm/mNm	34.6	30.8	33.3	32.2	33.9	33.5	37.3
15_ Mechanical time constant	ms	3.28	3.17	3.14	3.13	3.14	3.14	3.17
16_ Rotor inertia	gcm <sup>2</sup>	9.06	9.82	9.00	9.26	8.85	8.94	8.12

### Thermal data

17_ Thermal resistance housing-ambient	K/W	13.6
18_ Thermal resistance winding-housing	K/W	4.57
19_ Thermal time constant winding	s	22
20_ Thermal time constant motor	s	646
21_ Ambient temperature ball bearings	°C	-30...+85
21_ Ambient temperature sleeve bearings	°C	-30...+85
22_ Max. winding temperature	°C	100

### Operating Range

n [rpm] Winding 18 V

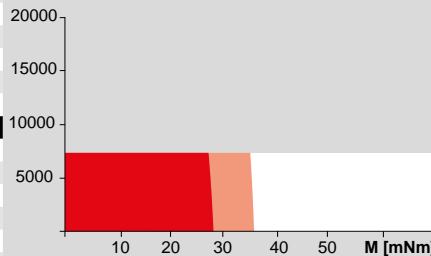

■ Continuous operation  
 ■ Continuous operation with reduced thermal resistance  $R_{th2}$  50%  
 □ Intermittent operation

### Mechanical data ball bearings

23_ Max. speed	rpm	7160
24_ Axial play	mm	0...0.1
Preload	N	2.5
25_ Radial play	mm	0.02
26_ Max. axial load (dynamic)	N	2.5
27_ Max. force for press fits (static)	N	30
(static, shaft supported)	N	440
28_ Max. radial load [mm from flange]	N	16 [5]

### Mechanical data sleeve bearings

23_ Max. speed	rpm	7160
24_ Axial play	mm	0...0.2
Preload	N	0
25_ Radial play	mm	0.02
26_ Max. axial load (dynamic)	N	0.1
27_ Max. force for press fits (static)	N	80
(static, shaft supported)	N	440
28_ Max. radial load [mm from flange]	N	3 [5]

### Other specifications

29_ Number of pole pairs		1
30_ Number of commutator segments		9
31_ Weight of motor	g	95
32_ Typical noise level	dB(A)	52

### maxon Modular System

<b>maxon gear</b>	Stages	<b>maxon sensor</b>	<b>maxon motor control</b>
68_GPX 22 A, C	1-2	82_ENX 10 QUAD	378_ESCON Module 24/2
69_GPX 22 LN, LZ	1-2	83_ENX 16 EASY	378_ESCON 36/2 DC
70_GPX 22 HP	2-3	84_ENX 16 EASY Abs.	379_ESCON 50/5
71_GPX 26 A, C	3	359_ENC SCH16F	379_ESCON Module 50/5
72_GPX 26 LN, LZ	3	367_ENC 30 HEDL 5540	386_EPOS2 24/2 (DC/EC)
			386_EPOS2 Module 36/2
			387_EPOS2 50/5
			390_EPOS2 P 24/5
			393_EPOS3 70/10 EtherCAT
			396_MAXPOS 50/5

### Configuration

Bearing: Ball bearings preloaded/sleeve bearings  
 Commutation: Precious metal brushes with or without CLL/graphite brushes/EMI filter  
 Flange front/back: Standard flange/configurable flange/no flange  
 Shaft front/back: Length/diameter/flat face  
 Electric connection: Terminals or cable/alignment of connection/cable length/connector type

xdrives.maxonmotor.com



# DCX 22 L Graphite Brushes

## DC motor Ø22 mm

20/49 W 32.2 mNm 18000 rpm

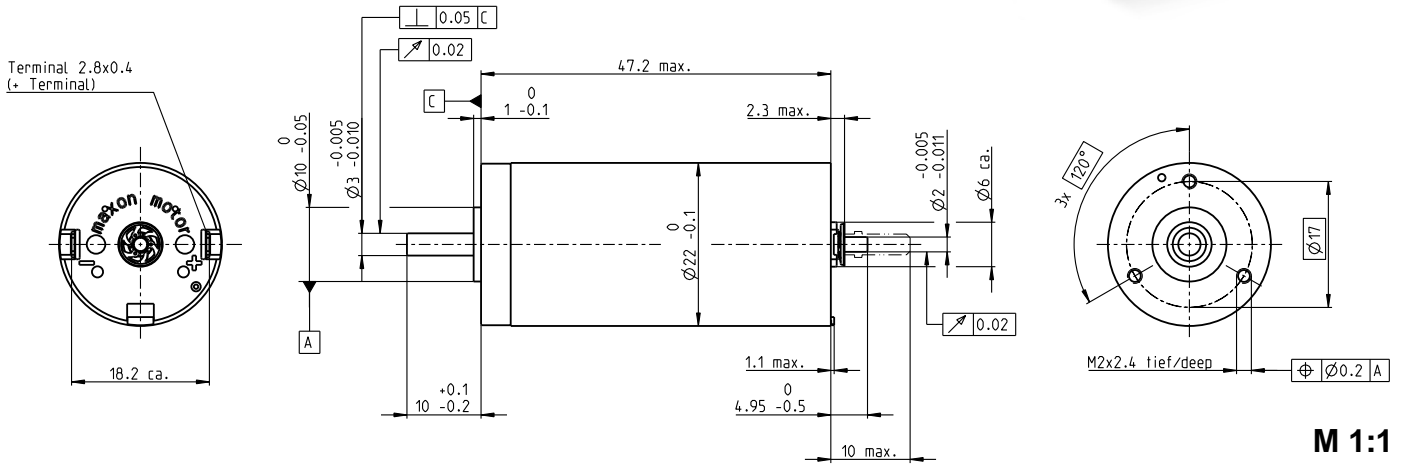

M 1:1

### Motor Data

1_	Nominal voltage	V	9	12	18	24	36	48
2_	No load speed	rpm	12300	11700	11800	9970	11400	10100
3_	No load current	mA	118	81.8	54.6	31.8	26.3	16.2
4_	Nominal speed	rpm	11400	10700	10800	8920	10400	9020
5_	Nominal torque (max. continuous torque)	mNm	27.0	30.5	32.2	31.5	30.0	30.3
6_	Nominal current (max. continuous current)	A	4.00	3.21	2.26	1.40	1.03	0.687
7_	Stall torque	mNm	371	348	386	301	346	294
8_	Stall current	A	53.4	35.8	26.5	13.1	11.6	6.50
9_	Max. efficiency	%	90	91	91	90	90	90
10_	Terminal resistance	Ω	0.168	0.335	0.680	1.83	3.11	7.39
11_	Terminal inductance	mH	0.018	0.035	0.078	0.192	0.326	0.746
12_	Torque constant	mNm/A	6.95	9.73	14.6	22.9	29.9	45.2
13_	Speed constant	rpm/V	1370	981	654	416	320	211
14_	Speed/torque gradient	rpm/mNm	33.3	33.8	30.5	33.2	33.3	34.6
15_	Mechanical time constant	ms	3.27	3.21	3.13	3.13	3.23	3.20
16_	Rotor inertia	gcm <sup>2</sup>	9.37	9.06	9.82	9.00	9.26	8.85

### Thermal data

17_	Thermal resistance housing-ambient	K/W	13.6
18_	Thermal resistance winding-housing	K/W	4.57
19_	Thermal time constant winding	s	22
20_	Thermal time constant motor	s	646
21_	Ambient temperature ball bearings	°C	-40...+100
21_	Ambient temperature sleeve bearings	°C	-30...+100
22_	Max. winding temperature	°C	125

### Operating Range

n [rpm] Winding 18 V

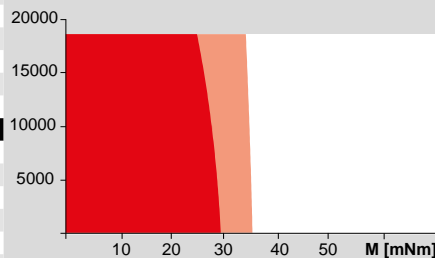

■ Continuous operation  
 ■ Continuous operation with reduced thermal resistance  $R_{th2}$  50%  
 □ Intermittent operation

### Mechanical data ball bearings

23_	Max. speed	rpm	18000
24_	Axial play	mm	0...0.1
	Preload	N	2.5
25_	Radial play	mm	0.02
26_	Max. axial load (dynamic)	N	2.5
27_	Max. force for press fits (static)	N	30
	(static, shaft supported)	N	440
28_	Max. radial load [mm from flange]	N	16 [5]

### Mechanical data sleeve bearings

23_	Max. speed	rpm	18000
24_	Axial play	mm	0...0.2
	Preload	N	0
25_	Radial play	mm	0.02
26_	Max. axial load (dynamic)	N	0.1
27_	Max. force for press fits (static)	N	80
	(static, shaft supported)	N	440
28_	Max. radial load [mm from flange]	N	3 [5]

### maxon Modular System

<b>maxon gear</b>	Stages	<b>maxon sensor</b>	<b>maxon motor control</b>
68_GPX 22 A, C	1-2	82_ENX 10 QUAD	378_ESCON Module 24/2
69_GPX 22 LN, LZ	1-2	83_ENX 16 EASY	378_ESCON 36/2 DC
70_GPX 22 HP	2-3	84_ENX 16 EASY Abs.	379_ESCON 50/5
71_GPX 26 A, C	3	359_ENC SCH16F	379_ESCON Module 50/5
72_GPX 26 LN, LZ	3	367_ENC 30 HEDL 5540	386_EPOS2 24/2 (DC/EC)
			386_EPOS2 Module 36/2
			387_EPOS2 24/5
			387_EPOS2 50/5
			390_EPOS2 P 24/5
			393_EPOS3 70/10 EtherCAT
			396_MAXPOS 50/5

### Other specifications

29_	Number of pole pairs		1
30_	Number of commutator segments		9
31_	Weight of motor	g	95
32_	Typical noise level	dBA	44

### Configuration

Bearing: Ball bearings preloaded/sleeve bearings  
 Commutation: Precious metal brushes with or without CLL/graphite brushes/EMI filter  
 Flange front/back: Standard flange/configurable flange/no flange  
 Shaft front/back: Length/diameter/flat face  
 Electric connection: Terminals or cable/alignment of connection/cable length/connector type

[xdrives.maxonmotor.com](http://xdrives.maxonmotor.com)

# DCX 26 L Precious Metal Brushes

## DC motor Ø26 mm

18/29 W 52.3 mNm 5900 rpm

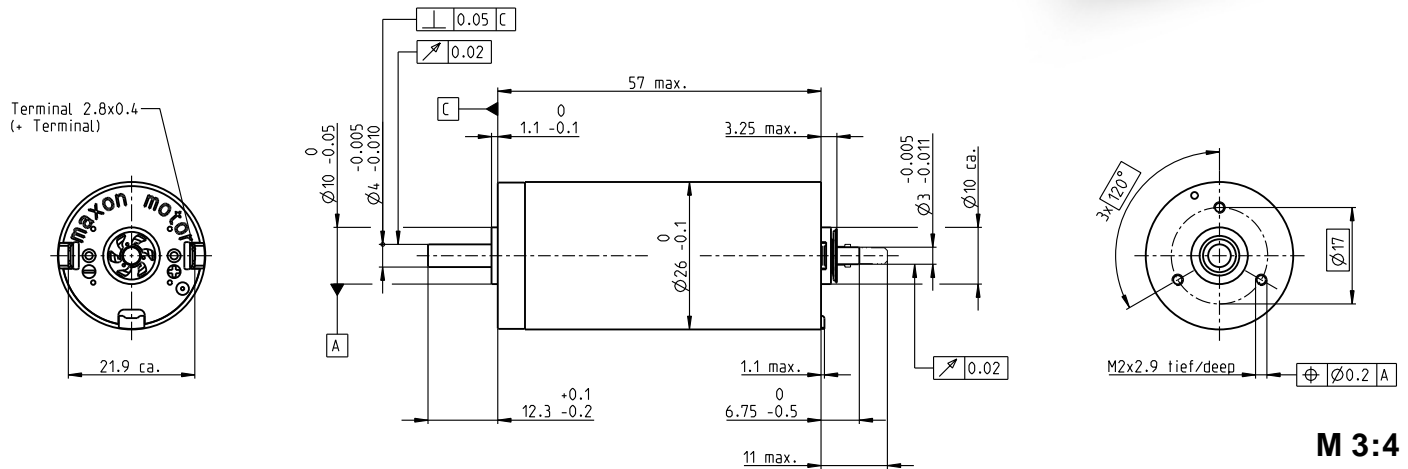

M 3:4

### Motor Data

	V	9	12	18	24	36	48
1_ Nominal voltage	V	9	12	18	24	36	48
2_ No load speed	rpm	5530	5330	5530	5330	5430	5320
3_ No load current	mA	80.5	56.8	40.2	28.4	19.5	14.2
4_ Nominal speed	rpm	5060	4690	4770	4600	4680	4570
5_ Nominal torque (max. continuous torque)	mNm	32.9	46.1	49.8	52.3	50.8	50.3
6_ Nominal current (max. continuous current)	A	2.20	2.20	1.64	1.25	0.822	0.599
7_ Stall torque	mNm	384	384	362	384	370	355
8_ Stall current	A	24.8	17.9	11.7	8.95	5.86	4.14
9_ Max. efficiency	%	89	89	89	89	89	89
10_ Terminal resistance	Ω	0.363	0.671	1.54	2.68	6.15	11.6
11_ Terminal inductance	mH	0.067	0.129	0.268	0.514	1.11	2.06
12_ Torque constant	mNm/A	15.5	21.4	31.0	42.9	63.2	85.8
13_ Speed constant	rpm/V	616	445	308	223	151	111
14_ Speed/torque gradient	rpm/mNm	14.4	13.9	15.3	13.9	14.7	15.0
15_ Mechanical time constant	ms	3.23	3.13	3.11	3.09	3.10	3.11
16_ Rotor inertia	gcm <sup>2</sup>	21.3	21.4	19.4	21.2	20.1	19.7

### Thermal data

17_ Thermal resistance housing-ambient	K/W	10.2
18_ Thermal resistance winding-housing	K/W	3.01
19_ Thermal time constant winding	s	24
20_ Thermal time constant motor	s	620
21_ Ambient temperature ball bearings	°C	-30...+85
21_ Ambient temperature sleeve bearings	°C	-30...+85
22_ Max. winding temperature	°C	100

### Operating Range

n [rpm] Winding 18 V

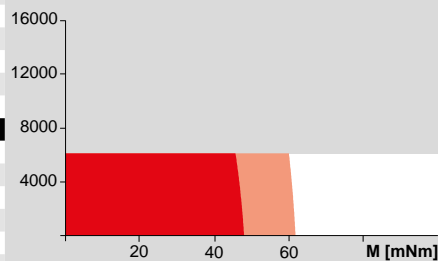

■ Continuous operation  
 ■ Continuous operation with reduced thermal resistance  $R_{th2}$  50%  
 ■ Intermittent operation

### Mechanical data ball bearings

23_ Max. speed	rpm	5900
24_ Axial play	mm	0...0.1
Preload	N	5.5
25_ Radial play	mm	0.02
26_ Max. axial load (dynamic)	N	5.5
27_ Max. force for press fits (static)	N	40
(static, shaft supported)	N	500
28_ Max. radial load [mm from flange]	N	20.5 [5]

### Mechanical data sleeve bearings

23_ Max. speed	rpm	5900
24_ Axial play	mm	0...0.2
Preload	N	0
25_ Radial play	mm	0.02
26_ Max. axial load (dynamic)	N	0.1
27_ Max. force for press fits (static)	N	80
(static, shaft supported)	N	500
28_ Max. radial load [mm from flange]	N	5.5 [5]

### maxon Modular System

maxon gear	Stages	maxon sensor	maxon motor control
71_GPX 26 A, C	1-2	82_ENX 10 QUAD	378_ESCON 36/2 DC
72_GPX 26 LN, LZ	1-2	83_ENX 16 EASY	379_ESCON 50/5
73_GPX 32 A, C	3	84_ENX 16 EASY Abs.	379_ESCON Module 50/5
74_GPX 32 LN, LZ	3	367_ENC 30 HEDL 5540	386_EPOS2 24/2 (DC/EC)
75_GPX 32 HP	4		386_EPOS2 Module 36/2
			387_EPOS2 24/5
			387_EPOS2 50/5
			390_EPOS2 P 24/5
			393_EPOS3 70/10 EtherCAT
			396_MAXPOS 50/5

### Other specifications

29_ Number of pole pairs		1
30_ Number of commutator segments		11
31_ Weight of motor	g	170
32_ Typical noise level	dBA	48

### Configuration

Bearing: Ball bearings preloaded/sleeve bearings  
 Commutation: Precious metal brushes with CLL/graphite brushes  
 Flange front/back: Standard flange/configurable flange/no flange  
 Shaft front/back: Length/diameter/flat face  
 Electric connection: Terminals or cable/alignment of connection/cable length/connector type

xdrives.maxonmotor.com

# DCX 26 L Graphite Brushes

## DC motor Ø26 mm

40/74 W 59.8 mNm 14400 rpm

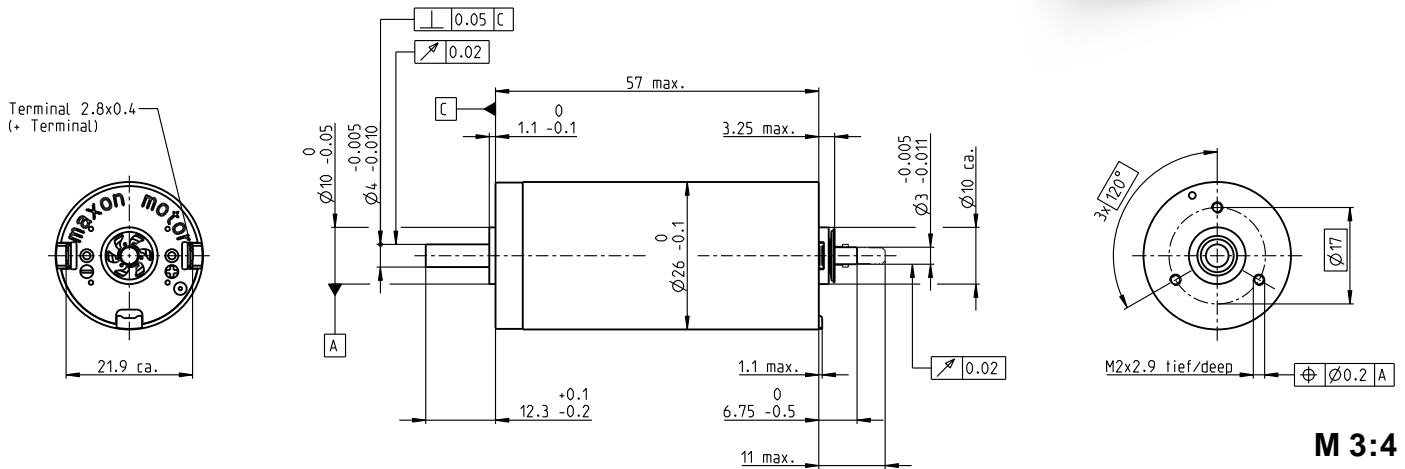

Motor Data							
1_ Nominal voltage	V	12	18	24	36	48	60
2_ No load speed	rpm	10600	11100	10700	11100	10700	10900
3_ No load current	mA	131	93.0	65.7	46.5	32.9	27.3
4_ Nominal speed	rpm	9460	10000	9690	10000	9730	10000
5_ Nominal torque (max. continuous torque)	mNm	46.9	54.3	57.8	54.0	59.1	59.8
6_ Nominal current (max. continuous current)	A	4.50	3.59	2.76	1.79	1.41	1.17
7_ Stall torque	mNm	532	653	695	639	697	750
8_ Stall current	A	49.7	42.2	32.4	20.6	16.2	14.3
9_ Max. efficiency	%	87	89	90	90	91	91
10_ Terminal resistance	Ω	0.242	0.427	0.740	1.75	2.95	4.19
11_ Terminal inductance	mH	0.032	0.067	0.129	0.268	0.514	0.768
12_ Torque constant	mNm/A	10.7	15.5	21.4	31.0	42.9	52.4
13_ Speed constant	rpm/V	890	616	445	308	223	182
14_ Speed/torque gradient	rpm/mNm	20.1	17.0	15.4	17.4	15.3	14.6
15_ Mechanical time constant	ms	4.50	3.79	3.45	3.53	3.40	3.16
16_ Rotor inertia	gcm <sup>2</sup>	21.4	21.3	21.4	19.4	21.2	20.7

Thermal data		Operating Range	
17_ Thermal resistance housing-ambient	K/W	10.2	
18_ Thermal resistance winding-housing	K/W	3.01	
19_ Thermal time constant winding	s	24	
20_ Thermal time constant motor	s	620	
21_ Ambient temperature ball bearings	°C	-40...+100	
21_ Ambient temperature sleeve bearings	°C	-30...+100	
22_ Max. winding temperature	°C	125	

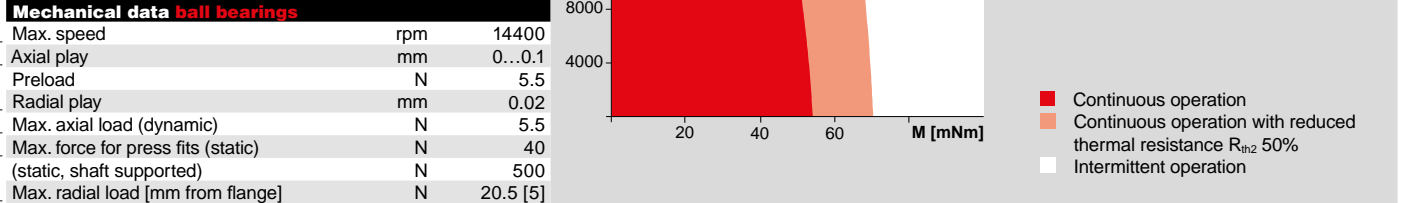

Mechanical data ball bearings		Mechanical data sleeve bearings		maxon Modular System	
23_ Max. speed	rpm	14400		maxon gear	Stages
24_ Axial play	mm	0...0.1		71_GPX 26 A, C	1-2
Preload	N	5.5		72_GPX 26 LN, LZ	1-2
25_ Radial play	mm	0.02		73_GPX 32 A, C	3
26_ Max. axial load (dynamic)	N	5.5		74_GPX 32 LN, LZ	3
27_ Max. force for press fits (static)	N	40		75_GPX 32 HP	4
(static, shaft supported)	N	500			
28_ Max. radial load [mm from flange]	N	20.5 [5]			

Other specifications		maxon sensor		maxon motor control	
29_ Number of pole pairs		1		378_ESCON 36/2 DC	
30_ Number of commutator segments		11		379_ESCON 50/5	
31_ Weight of motor	g	170		379_ESCON Module 50/5	
32_ Typical noise level	dBA	44		386_EPOS2 24/2 (DC/EC)	
				386_EPOS2 Module 36/2	
				387_EPOS2 24/5	
				387_EPOS2 50/5	
				390_EPOS2 P 24/5	
				393_EPOS3 70/10 EtherCAT	
				396_MAXPOS 50/5	

**Configuration**  
 Bearing: Ball bearings preloaded/sleeve bearings  
 Commutation: Precious metal brushes with CLL/graphite brushes  
 Flange front/back: Standard flange/configurable flange/no flange  
 Shaft front/back: Length/diameter/flat face  
 Electric connection: Terminals or cable/alignment of connection/cable length/connector type

xdrives.maxonmotor.com



# DCX 32 L Graphite Brushes

## DC motor Ø32 mm

70/110 W 128 mNm 11300 rpm

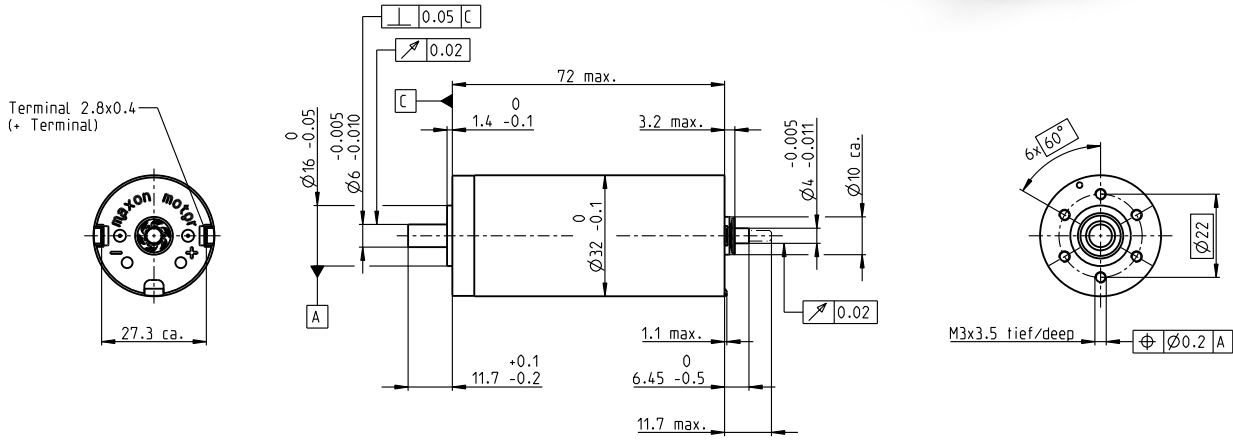

M 1:2

### Motor Data

1_	Nominal voltage	V	12	18	24	36	48	60
2_	No load speed	rpm	7120	8630	8270	7940	7780	5840
3_	No load current	mA	274	234	164	103	75.2	41.6
4_	Nominal speed	rpm	6560	8070	7710	7410	7260	5290
5_	Nominal torque (max. continuous torque)	mNm	89.4	101	108	119	123	128
6_	Nominal current (max. continuous current)	A	6.00	5.42	4.12	2.87	2.17	1.35
7_	Stall torque	mNm	1730	2120	1980	2020	2000	1420
8_	Stall current	A	111	109	72.5	47.1	34.2	14.5
9_	Max. efficiency	%	85	88	88	90	90	89
10_	Terminal resistance	Ω	0.108	0.165	0.331	0.764	1.40	4.12
11_	Terminal inductance	mH	0.034	0.053	0.103	0.254	0.473	1.31
12_	Torque constant	mNm/A	15.6	19.5	27.3	42.9	58.5	97.5
13_	Speed constant	rpm/V	612	490	350	223	163	97.9
14_	Speed/torque gradient	rpm/mNm	4.24	4.15	4.24	3.96	3.92	4.14
15_	Mechanical time constant	ms	3.44	3.30	3.24	3.19	3.11	3.11
16_	Rotor inertia	gcm <sup>2</sup>	77.6	75.9	72.8	76.8	75.9	71.7

### Thermal data

17_	Thermal resistance housing-ambient	K/W	7.28
18_	Thermal resistance winding-housing	K/W	2.3
19_	Thermal time constant winding	s	42.2
20_	Thermal time constant motor	s	837
21_	Ambient temperature	°C	-40...+100
22_	Max. winding temperature	°C	155

### Operating Range

n [rpm] Winding 36 V

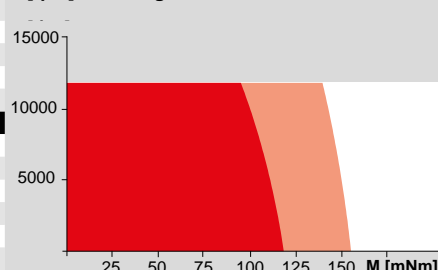

■ Continuous operation  
■ Continuous operation with reduced thermal resistance  $R_{th2}$  50%  
■ Intermittent operation

### Mechanical data ball bearings

23_	Max. speed	rpm	11300
24_	Axial play	mm	0...0.1
	Preload	N	7
25_	Radial play	mm	0.02
26_	Max. axial load (dynamic)	N	7
27_	Max. force for press fits (static) (static, shaft supported)	N	22.6 2510
28_	Max. radial load [mm from flange]	N	65.3 [5]

### Other specifications

29_	Number of pole pairs		1
30_	Number of commutator segments		11
31_	31 Weight of motor	g	325
32_	Typical noise level	dBA	47

### maxon Modular System

<b>maxon gear</b>	Stages	<b>maxon sensor</b>	<b>maxon motor control</b>
73_GPX 32 A, C	1-2	82_ENX 10 QUAD	379_ESCON 50/5
74_GPX 32 LN, LZ	1-2	83_ENX 16 EASY	379_ESCON Module 50/5
75_GPX 32 HP	2-3	84_ENX 16 EASY Abs.	379_ESCON 70/10
76_GPX 37 A	3	360_ENC 2RMHF	387_EPOS2 24/5
77_GPX 37 LN, LZ	3	367_ENC 30 HEDL 5540	387_EPOS2 50/5
			387_EPOS2 70/10
			390_EPOS2 P 24/5
			393_EPOS3 70/10 EtherCAT
			396_MAXPOS 50/5

### Configuration

Bearing: Ball bearings preloaded  
 Commutation: Graphite brushes  
 Flange front/back: Standard flange/configurable flange/no flange  
 Shaft front/back: Length/diameter/flat face  
 Electric connection: Terminals or cable/alignment of connection/cable length/connector type

xdrives.maxonmotor.com

# DCX 35 L Graphite Brushes

## DC motor Ø35 mm

80/120 W 138 mNm 12300 rpm

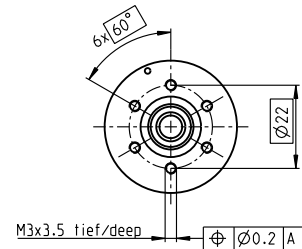
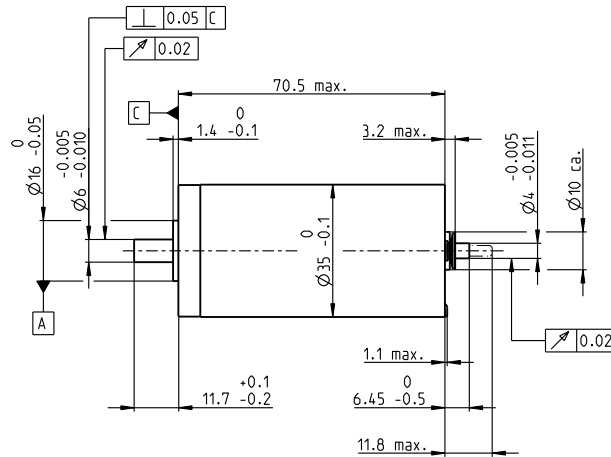
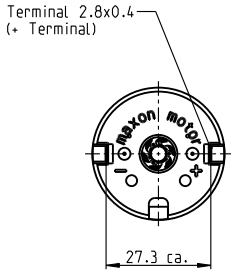

M 1:2

### Motor Data

		12	18	24	36	48	60
1_ Nominal voltage	V	12	18	24	36	48	60
2_ No load speed	rpm	8130	7200	7720	7940	6670	7690
3_ No load current	mA	320	177	146	101	58.6	57.5
4_ Nominal speed	rpm	7610	6640	7160	7410	6140	7160
5_ Nominal torque (max. continuous torque)	mNm	77.7	120	121	128	138	132
6_ Nominal current (max. continuous current)	A	6.00	5.32	4.26	3.07	2.08	1.84
7_ Stall torque	mNm	2080	1980	2030	2160	1860	2050
8_ Stall current	A	152	84.8	69.3	50.3	27.3	27.7
9_ Max. efficiency	%	85	88	89	90	90	90
10_ Terminal resistance	Ω	0.079	0.212	0.346	0.716	1.76	2.16
11_ Terminal inductance	mH	0.026	0.077	0.121	0.260	0.658	0.776
12_ Torque constant	mNm/A	13.7	23.4	29.3	42.9	68.3	74.1
13_ Speed constant	rpm/V	699	408	326	223	140	129
14_ Speed/torque gradient	rpm/mNm	4.04	3.70	3.86	3.72	3.61	3.76
15_ Mechanical time constant	ms	4.21	3.97	3.91	3.84	3.76	3.75
16_ Rotor inertia	gcm <sup>2</sup>	99.5	102	96.6	98.7	99.5	95.2

### Thermal data

			Operating Range
17_ Thermal resistance housing-ambient	K/W	6.98	n [rpm] Winding 36 V
18_ Thermal resistance winding-housing	K/W	2.1	
19_ Thermal time constant winding	s	43.9	
20_ Thermal time constant motor	s	1030	
21_ Ambient temperature	°C	-40...+100	
22_ Max. winding temperature	°C	155	

### Mechanical data ball bearings

23_ Max. speed	rpm	12300
24_ Axial play	mm	0...0.1
Preload	N	7
25_ Radial play	mm	0.02
26_ Max. axial load (dynamic)	N	7
27_ Max. force for press fits (static) (static, shaft supported)	N	22.6 / 2510
28_ Max. radial load [mm from flange]	N	65.3 [5]

### Other specifications

		maxon Modular System		
29_ Number of pole pairs		1	maxon gear	Stages
30_ Number of commutator segments		11	76_GPX 37 A	1-2
31_ 31 Weight of motor	g	385	77_GPX 37 LN, LZ	1-2
32_ Typical noise level	dBA	48	78_GPX 42 C	1-4

	maxon sensor	maxon motor control
82_ENX 10 QUAD	379_ESCON 50/5	
83_ENX 16 EASY	379_ESCON Module 50/5	
84_ENX 16 EASY Abs.	379_ESCON 70/10	
360_ENC 2RMHF	387_EPOS2 24/5	
367_ENC 30 HEDL 5540	387_EPOS2 50/5	
	387_EPOS2 70/10	
	390_EPOS2 P 24/5	
	393_EPOS3 70/10 EtherCAT	
	396_MAXPOS 50/5	

### Configuration

Bearing: Ball bearings preloaded  
 Commutation: Graphite brushes  
 Flange front/back: Standard flange/configurable flange/no flange  
 Shaft front/back: Length/diameter/flat face  
 Electric connection: Terminals or cable/alignment of connection/cable length/connector type

xdrives.maxonmotor.com





# maxon *DC-max*

## Brushed DC motors **maxon DC-max**

Strong RE magnets, state-of-the-art winding technology, cost-optimized design, economical manufacturing: The maxon DC-max motors feature maximum performance at minimum volume and an unrivaled price-performance ratio.

maxon DC-max motors can be configured online and are ready for delivery within 11 working days.

[dcmx.maxonmotor.com](http://dcmx.maxonmotor.com)



**maxon motor**

driven by precision

# DC-max 16 S Precious Metal Brushes

## DC motor Ø16 mm



2/4.3 W 4.1 mNm 11000 rpm

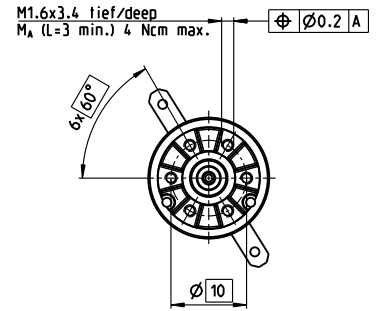
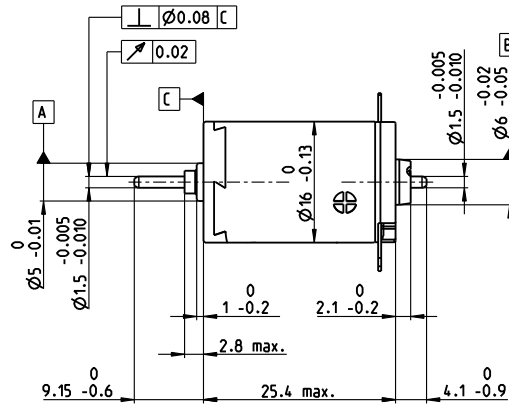
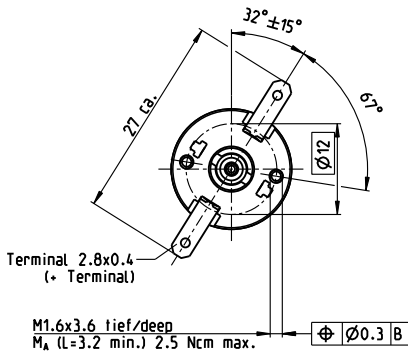

M 1:1

### Motor Data

1_ Nominal voltage	V	6	12	24
2_ No load speed	rpm	7890	7560	7470
3_ No load current	mA	14.7	6.90	3.40
4_ Nominal speed	rpm	4830	4390	4210
5_ Nominal torque (max. continuous torque)	mNm	4.06	3.92	3.80
6_ Nominal current (max. continuous current)	A	0.577	0.267	0.128
7_ Stall torque	mNm	10.5	9.44	8.75
8_ Stall current	A	1.46	0.629	0.289
9_ Max. efficiency	%	81	80	80
10_ Terminal resistance	Ω	4.10	19.1	83.2
11_ Terminal inductance	mH	0.140	0.610	2.49
12_ Torque constant	mNm/A	7.19	15.0	30.3
13_ Speed constant	rpm/V	1330	637	315
14_ Speed/torque gradient	rpm/mNm	758	809	864
15_ Mechanical time constant	ms	8.87	8.92	9.00
16_ Rotor inertia	gcm <sup>2</sup>	1.12	1.05	0.994

### Thermal data

17_ Thermal resistance housing-ambient	K/W	29.8
18_ Thermal resistance winding-housing	K/W	5.5
19_ Thermal time constant winding	s	5.35
20_ Thermal time constant motor	s	288
21_ Ambient temperature	°C	-30...+65
22_ Max. winding temperature	°C	85

### Operating Range

n [rpm] Winding 12 V

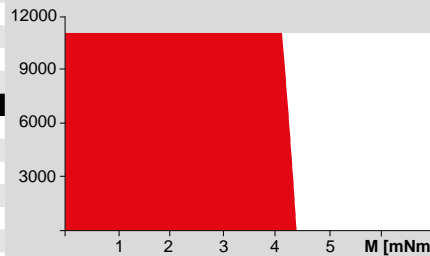

■ Continuous operation  
■ Continuous operation with reduced thermal resistance  $R_{th2}$  50%  
■ Intermittent operation

### Mechanical data ball bearings

23_ Max. speed	rpm	11000
24_ Axial play	mm	0.15...0.05
Preload	N	0
25_ Radial play	mm	0.025
26_ Max. axial load (dynamic)	N	2.2
27_ Max. force for press fits (static) (static, shaft supported)	N	30
28_ Max. radial load [mm from flange]	N	200

### Mechanical data sleeve bearings

23_ Max. speed	rpm	11000
24_ Axial play	mm	0.15...0.05
Preload	N	0
25_ Radial play	mm	0.012
26_ Max. axial load (dynamic)	N	0.8
27_ Max. force for press fits (static) (static, shaft supported)	N	35
28_ Max. radial load [mm from flange]	N	200

### maxon Modular System

<b>maxon gear</b>	Stages
62_GPX 16 A, C	1-2
63_GPX 16 LN, LZ	1-2
66_GPX 19 A, C	3-4
67_GPX 19 LN, LZ	3-4

<b>maxon sensor</b>
82_ENX 10 QUAD
82_ENX 10 EASY

<b>maxon motor control</b>
378_ESCON Module 24/2
378_ESCON 36/2 DC
386_EPOS2 24/2 (DC/EC)
386_EPOS2 Module 36/2
393_EPOS3 70/10 EtherCAT
396_MAXPOS 50/5

### Other specifications

29_ Number of pole pairs		1
30_ Number of commutator segments		7
31_ Weight of motor	g	23.3

### Configuration

Bearing: Sleeve bearings/ball bearings  
 Commutation: Precious metal brushes with CLL/Graphite Brushes  
 Shaft front/back: Length  
 Electric connection: Terminals/cable

xdrives.maxonmotor.com

# DC-max 16 S Graphite Brushes

## DC motor Ø16 mm

3/4.7 W 4.8 mNm 11 000 rpm

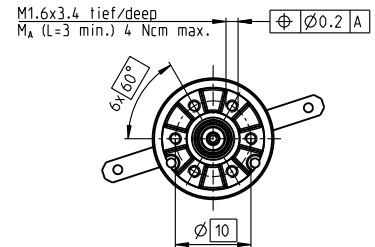
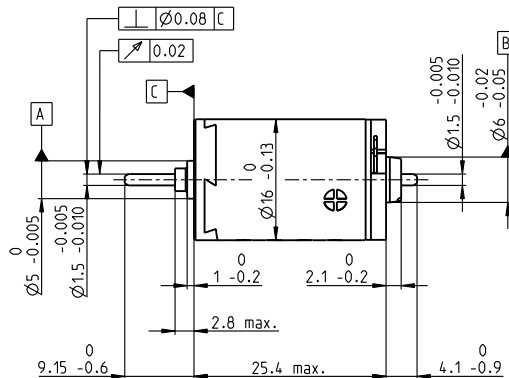
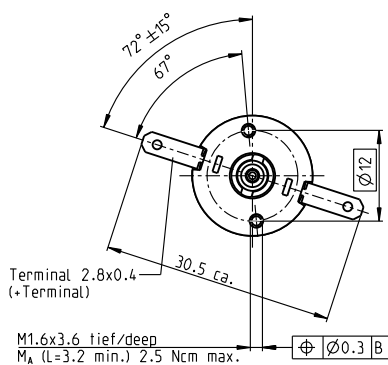

M 1:1

### Motor Data

1_ Nominal voltage	V	6	12	24
2_ No load speed	rpm	9870	9860	9920
3_ No load current	mA	67.3	33.6	16.8
4_ Nominal speed	rpm	6770	6200	6580
5_ Nominal torque (max. continuous torque)	mNm	3.71	4.31	4.76
6_ Nominal current (max. continuous current)	A	0.720	0.413	0.227
7_ Stall torque	mNm	12.1	11.9	14.4
8_ Stall current	A	2.15	1.05	0.64
9_ Max. efficiency	%	68	68	71
10_ Terminal resistance	Ω	2.79	11.4	37.5
11_ Terminal inductance	mH	0.086	0.343	1.37
12_ Torque constant	mNm/A	5.62	11.2	22.5
13_ Speed constant	rpm/V	1700	849	424
14_ Speed/torque gradient	rpm/mNm	843	858	707
15_ Mechanical time constant	ms	8.85	8.92	8.57
16_ Rotor inertia	gcm <sup>2</sup>	1.00	0.993	1.16

### Thermal data

17_ Thermal resistance housing-ambient	K/W	29.8
18_ Thermal resistance winding-housing	K/W	5.5
19_ Thermal time constant winding	s	5.35
20_ Thermal time constant motor	s	288
21_ Ambient temperature	°C	-30...+85
22_ Max. winding temperature	°C	125

### Operating Range

n [rpm] Winding 24 V

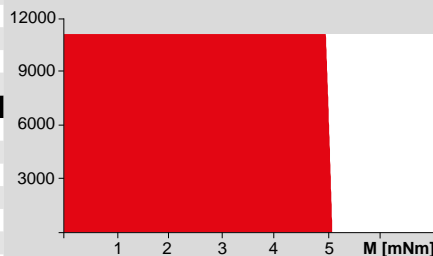

■ Continuous operation  
■ Continuous operation with reduced thermal resistance  $R_{th2}$  50%  
■ Intermittent operation

### Mechanical data ball bearings

23_ Max. speed	rpm	11 000
24_ Axial play	mm	0.15...0.05
Preload	N	0
25_ Radial play	mm	0.025
26_ Max. axial load (dynamic)	N	2.2
27_ Max. force for press fits (static) (static, shaft supported)	N	30
28_ Max. radial load [mm from flange]	N	200
	N	7.8 [5]

### Mechanical data sleeve bearings

23_ Max. speed	rpm	11 000
24_ Axial play	mm	0.15...0.05
Preload	N	0
25_ Radial play	mm	0.012
26_ Max. axial load (dynamic)	N	0.8
27_ Max. force for press fits (static) (static, shaft supported)	N	35
28_ Max. radial load [mm from flange]	N	200
	N	1.4 [5]

### maxon Modular System

<b>maxon gear</b>	Stages
62_GPX 16 A, C	1-2
63_GPX 16 LN, LZ	1-2
66_GPX 19 A, C	3-4
67_GPX 19 LN, LZ	3-4

<b>maxon sensor</b>
82_ENX 10 QUAD
82_ENX 10 EASY

<b>maxon motor control</b>
378_ESCON Module 24/2
378_ESCON 36/2 DC
386_EPOS2 24/2 (DC/EC)
386_EPOS2 Module 36/2
393_EPOS3 70/10 EtherCAT
396_MAXPOS 50/5

### Other specifications

29_ Number of pole pairs		1
30_ Number of commutator segments		7
31_ Weight of motor	g	23.1

### Configuration

Bearing: Sleeve bearings/ball bearings  
 Commutation: Precious metal brushes with CLL/Graphite Brushes  
 Shaft front/back: Length  
 Electric connection: Terminals/cable

xd rives.maxonmotor.com

# DC-max 22 S Precious Metal Brushes

## DC motor Ø22 mm

5/9.6 W 10.4 mNm 9000 rpm

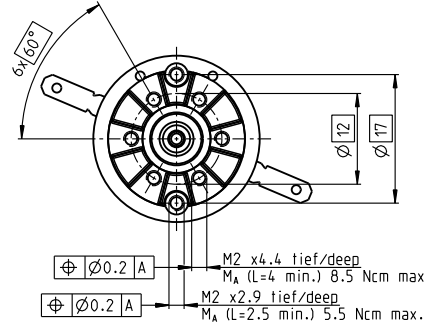
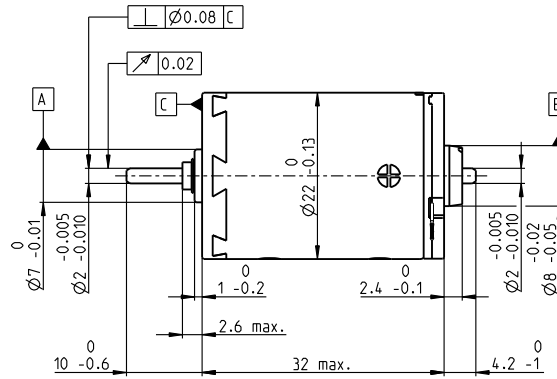
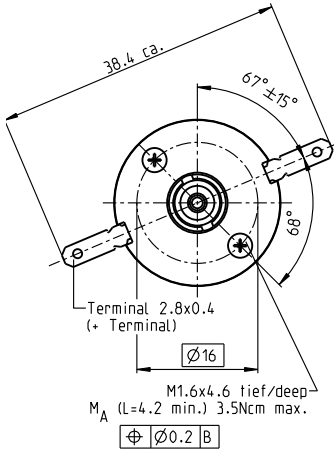

M 1:1

### Motor Data

1_ Nominal voltage	V	6	12	24
2_ No load speed	rpm	5500	5900	5100
3_ No load current	mA	13.6	7.49	3.07
4_ Nominal speed	rpm	4280	4240	3440
5_ Nominal torque (max. continuous torque)	mNm	8.60	10.4	10.4
6_ Nominal current (max. continuous current)	A	0.840	0.543	0.236
7_ Stall torque	mNm	39.0	36.9	32.3
8_ Stall current	A	3.75	1.91	0.721
9_ Max. efficiency	%	88	88	88
10_ Terminal resistance	Ω	1.60	6.28	33.3
11_ Terminal inductance	mH	0.119	0.413	2.21
12_ Torque constant	mNm/A	10.4	19.3	44.8
13_ Speed constant	rpm/V	919	494	213
14_ Speed/torque gradient	rpm/mNm	141	160	159
15_ Mechanical time constant	ms	8.44	8.36	8.39
16_ Rotor inertia	gcm <sup>2</sup>	5.70	4.98	5.05

### Thermal data

17_ Thermal resistance housing-ambient	K/W	20
18_ Thermal resistance winding-housing	K/W	6
19_ Thermal time constant winding	s	16.8
20_ Thermal time constant motor	s	538
21_ Ambient temperature	°C	-30...65
22_ Max. winding temperature	°C	85

### Operating Range

n [rpm] Winding 12 V

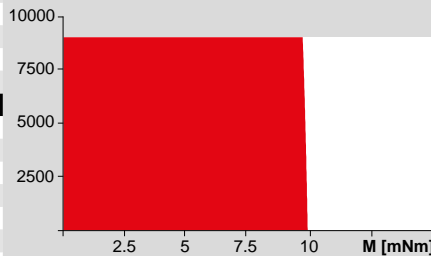

- Continuous operation
- Continuous operation with reduced thermal resistance R<sub>th2</sub> 50%
- Intermittent operation

### Mechanical data ball bearings

23_ Max. speed	rpm	9000
24_ Axial play	mm	0.05...0.15
Preload	N	0
25_ Radial play	mm	0.025
26_ Max. axial load (dynamic)	N	3.3
27_ Max. force for press fits (static) (static, shaft supported)	N	45
28_ Max. radial load [mm from flange]	N	420
		12.3 [5]

### Mechanical data sleeve bearings

23_ Max. speed	rpm	9000
24_ Axial play	mm	0.15...0.05
Preload	N	0
25_ Radial play	mm	0.012
26_ Max. axial load (dynamic)	N	1
27_ Max. force for press fits (static) (static, shaft supported)	N	80
28_ Max. radial load [mm from flange]	N	420
		2.8 [5]

### maxon Modular System

<b>maxon gear</b>	Stages	<b>maxon sensor</b>	<b>maxon motor control</b>
68_GPX 22 A, C	1-2	82_ENX 10 QUAD	378_ESCON Module 24/2
69_GPX 22 LN, LZ	1-2	82_ENX 10 EASY	378_ESCON 36/2 DC
71_GPX 26 A, C	3		386_EPOS2 24/2 (DC/EC)
72_GPX 26 LN, LZ	3		386_EPOS2 Module 36/2
			393_EPOS3 70/10 EtherCAT
			396_MAXPOS 50/5

### Other specifications

29_ Number of pole pairs		1
30_ Number of commutator segments		9
31_ Weight of motor	g	53.8

### Configuration

Bearing: Sleeve bearings/ball bearings  
 Commutation: Precious metal brushes with CLL/Graphite Brushes  
 Shaft front/back: Length  
 Electric connection: Terminals/cable

xdrives.maxonmotor.com



# DC-max 22 S Graphite Brushes

## DC motor Ø22 mm

8/10 W 12.5 mNm 9000 rpm

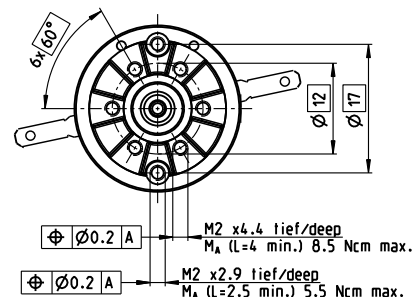
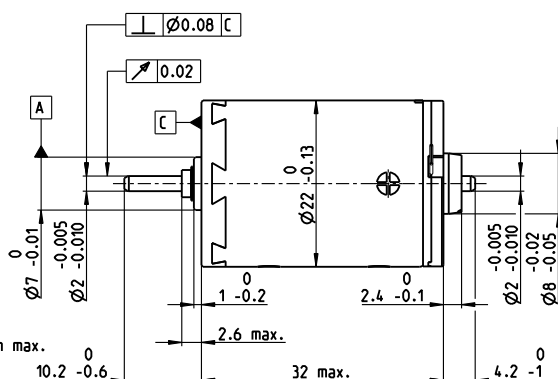
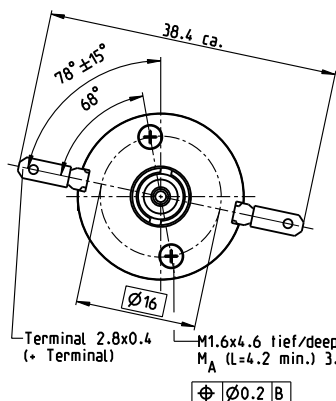

M 1:1

### Motor Data

1_	Nominal voltage	V	6	12	24
2_	No load speed	rpm	7030	7140	7330
3_	No load current	mA	58.8	29.5	15.1
4_	Nominal speed	rpm	4980	5260	5350
5_	Nominal torque (max. continuous torque)	mNm	11.3	12.5	11.8
6_	Nominal current (max. continuous current)	A	1.49	0.818	0.397
7_	Stall torque	mNm	42.4	49.4	44.6
8_	Stall current	A	5.39	3.14	1.45
9_	Max. efficiency	%	76	80	80
10_	Terminal resistance	Ω	1.11	3.83	16.6
11_	Terminal inductance	mH	0.069	0.274	1.05
12_	Torque constant	mNm/A	7.88	15.8	30.8
13_	Speed constant	rpm/V	1210	606	310
14_	Speed/torque gradient	rpm/mNm	171	147	167
15_	Mechanical time constant	ms	9.09	8.57	8.20
16_	Rotor inertia	gcm <sup>2</sup>	5.07	5.57	4.69

### Thermal data

17_	Thermal resistance housing-ambient	K/W	20
18_	Thermal resistance winding-housing	K/W	6
19_	Thermal time constant winding	s	16.8
20_	Thermal time constant motor	s	538
21_	Ambient temperature	°C	-30...85
22_	Max. winding temperature	°C	125

### Operating Range

n [rpm] Winding 12 V

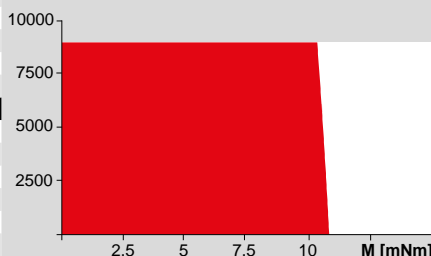

■ Continuous operation  
 ■ Continuous operation with reduced thermal resistance  $R_{th2}$  50%  
 □ Intermittent operation

### Mechanical data ball bearings

23_	Max. speed	rpm	9000
24_	Axial play	mm	0.05...0.15
	Preload	N	0
25_	Radial play	mm	0.025
26_	Max. axial load (dynamic)	N	3.3
27_	Max. force for press fits (static) (static, shaft supported)	N	45 420
28_	Max. radial load [mm from flange]	N	12.3 [5]

### Mechanical data sleeve bearings

23_	Max. speed	rpm	9000
24_	Axial play	mm	0.05...0.15
	Preload	N	0
25_	Radial play	mm	0.012
26_	Max. axial load (dynamic)	N	1
27_	Max. force for press fits (static) (static, shaft supported)	N	80 420
28_	Max. radial load [mm from flange]	N	2.8 [5]

### maxon Modular System

<b>maxon gear</b>	Stages	<b>maxon sensor</b>	<b>maxon motor control</b>
68_GPX 22 A, C	1-2	82_ENX 10 QUAD	378_ESCON Module 24/2
69_GPX 22 LN, LZ	1-2	82_ENX 10 EASY	378_ESCON 36/2 DC
71_GPX 26 A, C	3		386_EPOS2 24/2 (DC/EC)
72_GPX 26 LN, LZ	3		386_EPOS2 Module 36/2
			393_EPOS3 70/10 EtherCAT
			396_MAXPOS 50/5

### Other specifications

29_	Number of pole pairs	1
30_	Number of commutator segments	9
31_	Weight of motor	g 53.8

### Configuration

Bearing: Sleeve bearings/ball bearings  
 Commutation: Precious metal brushes with CLL/Graphite Brushes  
 Shaft front/back: Length  
 Electric connection: Terminals/cable

xdrives.maxonmotor.com

# Explanation for Terminology maxon DCX and DC-max

## Dimensional drawings

Presentation of the views according to the projection method E (ISO).  All dimensions in [mm].

## Mounting in plastic

Screwed connections on motors with plastic flanges require special attention.

## $M_A$ Max. tightening torque [Ncm]

A torque screw driver may be adjusted to this value.

## L Active depth of screw connection [mm]

The relation of the depth of the screw connection to the thread diameter must be at least 2:1. The depth of the screw connection must be less than the usable length of the thread!

## Motor Data

The values stated are based on a motor temperature of 25°C (so-called cold data).

## 1 Nominal voltage $U_N$ [Volt]

is the DC voltage on the motor connections on which all nominal data are based (lines 2–9). Lower and higher voltages are permissible, provided set limits are not exceeded.

## 2 No load speed $n_0$ [rpm] $\pm 10\%$

This is the speed at which the motor turns at nominal voltage and without load. It is approximately proportional to the applied voltage.

## 3 No load current $I_0$ [mA] $\pm 50\%$

This is the typical current that the unloaded motor draws when operating at nominal voltage. It depends on brush friction and friction in the bearings, and also increases with rising speed. No load friction depends heavily on temperature, particularly with precious metal commutation. In extended operation, no load friction decreases and increases at lower temperatures.

## 4 Nominal speed $n_N$ [rpm]

is the speed set for operation at nominal voltage and nominal torque at a motor temperature of 25°C.

## 5 Nominal torque $M_N$ [mNm]

is the torque generated for operation at nominal voltage and nominal current at a motor temperature of 25°C. It is at the limit of the motor's continuous operation range. Higher torques heat up the winding too much.

## 6 Nominal current $I_N$ [A]

is the current that, at 25°C ambient temperature, heats the winding up to the maximum permissible temperature (= max. permissible continuous current).  $I_N$  decreases as speed increases due to additional friction losses.

## 7 Stall torque $M_H$ [mNm]

is the torque produced by the motor when at standstill. Rising motor temperatures reduce stall torque.

## 8 Stall current $I_A$ [A]

is the quotient from nominal voltage and the motor's terminal resistance. Stall current is equivalent to stall torque. With larger motors,  $I_A$  cannot often be reached due to the amplifier's current limits.

## 9 Max. efficiency $\eta_{max}$ [%]

is the optimal relationship between input and output power at nominal voltage. It also doesn't always denote the optimal operating point.

## 10 Terminal resistance $R$ [ $\Omega$ ]

is the resistance at the terminals at 25°C and determines the stall current at a given voltage. For graphite brushes, it should be noted that resistance is load-dependent and the value only applies to large currents.

## 11 Terminal inductance $L$ [mH]

is the winding inductance when stationary and measured at 1 kHz, sinusoidal.

## 12 Torque constant $k_M$ [mNm/A]

This may also be referred to as "specific torque" and represents the quotient from generated torque and applicable current.

## 13 Speed constant $k_n$ [rpm/V]

shows the ideal no load speed per 1 volt of applied voltage. Friction losses not taken into account.

## 14 Speed / torque gradient

$$\Delta n / \Delta M \text{ [rpm/mNm]}$$

The speed / torque gradient is an indicator of the motor's performance. The smaller the value, the more powerful the motor and consequently the less motor speed varies with load variations. It is based on the quotient of ideal no load speed and ideal stall torque.

## 15 Mechanical time constant

$$\tau_m \text{ [ms]}$$

is the time required for the rotor to accelerate from standstill to 63% of its no load speed.

## 16 Rotor inertia $J_R$ [gcm<sup>2</sup>]

is the mass moment of inertia of the rotor, based on the axis of rotation.

## 17 Thermal resistance

$$\text{housing-ambient } R_{th2} \text{ [K/W]}$$

and

## 18 Thermal resistance

$$\text{winding-housing } R_{th1} \text{ [K/W]}$$

Characteristic values of thermal contact resistance without additional heat sinking. Lines 17 and 18 combined define the maximum heating at a given power loss (load). Thermal resistance  $R_{th2}$  on motors with metal flanges can decrease by up to 80% if the motor is coupled directly to a good heat-conducting (e.g. metallic) mounting rather than a plastic panel.

## 19 Thermal time constant winding $\tau_w$ [s]

and

## 20 Thermal time constant motor $\tau_s$ [s]

These are the typical reaction times for a temperature change of winding and motor. It can be seen that the motor reacts much more sluggishly in thermal terms than the winding. The values are calculated from the product of thermal capacity and given heat resistances.

## 21 Ambient temperature [°C]

Operating temperature range. This derives from the heat reliability of the materials used and viscosity of bearing lubrication.

## 22 Max. winding temperature [°C]

Maximum permissible winding temperature.

## 23 Max. speed

$$n_{max} \text{ [rpm]}$$

is the maximum recommended speed based on thermal and mechanical perspectives. A reduced service life can be expected at higher speeds.

## 24 Axial play [mm]

On motors that are not preloaded, these are the tolerance limits for the bearing play. A preload cancels out the axial play up to the specified axial force. When load is applied in the direction of the preload force (away from the flange), the axial play is always zero. The length tolerance of the shaft includes the maximum axial play.

## 25 Radial play [mm]

Radial play is the bearing's radial movement. A spring is utilized to preload the motor's bearings, eliminating radial play up to a given axial load.

## 26 / 27 Max. axial load [N]

**Dynamically:** axial load permissible in operation. If different values apply for traction and thrust, the smaller value is given.

**Statically:** maximum axial force applying to the shaft at standstill where no residual damage occurs.

**Shaft supported:** maximum axial force applying to the shaft at standstill if the force is not input at the other shaft end. This is not possible for motors with only one shaft end.

## 28 Max. radial load [N]

The value is given for a typical clearance from the flange; this value falls the greater the clearance.

## 29 Number of pole pairs

Number of north poles of the permanent magnet. The phase streams and commutation signals pass through per revolution  $p$  cycles. Servo-controllers require the correct details of the number of pole pairs.

## 30 Number of commutator segments

## 31 Weight of motor [g]

## 32 Typical noise level [dBA]

is that statistical average of the noise level measured according to maxon standard (10 cm distance radially to the drive, no load operation at a speed of 6,000 rpm. The drive lies freely on a plastic foam mat in the noise chamber).

The acoustic noise level depends on a number of factors, such as component tolerances, and it is greatly influenced by the overall system in which the drive is installed. When the drive is installed in an unfavorable constellation, the noise level may be significantly higher than the noise level of the drive alone.

The acoustic noise level is measured and determined during product qualification. In manufacturing, a structure-borne noise test is performed with defined limits. Impermissible deviations can thus be identified.

# maxon ECX

## Brushless DC motors maxon ECX

The brushless ECX motors (BLDC) are the perfect solution for applications that need 0–120000 rpm. Quiet, highly efficient, durable and perfectly tailored to your needs – they are available in standard, high-power and sterilizable versions.

maxon ECX motors can be configured online and are ready for delivery within 11 working days.

[ecx.maxonmotor.com](http://ecx.maxonmotor.com)



**maxon motor**

driven by precision



# ECX SPEED 8 M brushless BLDC motor Ø8 mm

**NEW**



**2/4.7 W 0.94 mNm 50000 rpm**

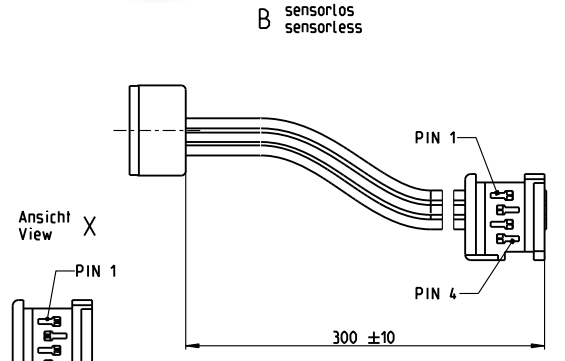
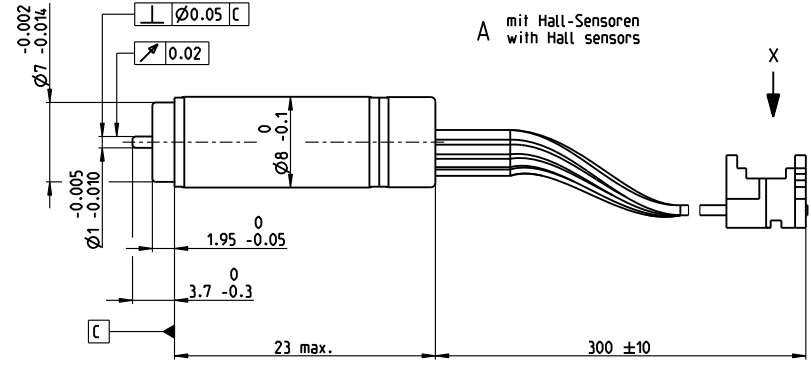

**Connector:**  
8 pole, 1.27 mm, MICA08  
Lumberg Connect GmbH

**Connector:**  
4 pole, 1.27 mm, MICA08  
Lumberg Connect GmbH

**M 3:2**

**Motor Data**

1_	Nominal voltage	V	6	12	24
2_	No load speed	rpm	34500	42200	41100
3_	No load current	mA	87.6	58.2	28
4_	Nominal speed	rpm	23300	31900	31100
5_	Nominal torque (max. continuous torque)	mNm	0.979	0.937	0.94
6_	Nominal current (max. continuous current)	A	0.689	0.408	0.199
7_	Stall torque	mNm	3.15	4.02	4.05
8_	Stall current	A	1.98	1.54	0.755
9_	Max. efficiency	%	63	66	66
10_	Terminal resistance	Ω	3.02	7.8	31.8
11_	Terminal inductance	mH	0.039	0.106	0.447
12_	Torque constant	mNm/A	1.59	2.61	5.37
13_	Speed constant	rpm/V	6020	3660	1780
14_	Speed/torque gradient	rpm/mNm	11500	10900	10500
15_	Mechanical time constant	ms	3	2.85	2.75
16_	Rotor inertia	gcm <sup>2</sup>	0.025	0.025	0.025

**Thermal data**

17_	Thermal resistance housing-ambient	K/W	51.2
18_	Thermal resistance winding-housing	K/W	3.5
19_	Thermal time constant winding	s	0.832
20_	Thermal time constant motor	s	154
21_	Ambient temperature <sup>1</sup>	°C	-20...+85
22_	Max. winding temperature	°C	125

**Operating Range**

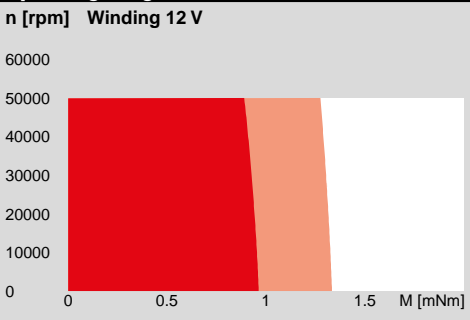

■ Continuous operation  
■ Continuous operation with reduced thermal resistance R<sub>th2</sub> 50%  
■ Short term operation

**Mechanical data ball bearings**

23_	Max. speed	rpm	50000
24_	Axial play	mm	0...0.07
	Preload	N	0.3
	Direction of force		pull
25_	Radial play		preloaded
26_	Max. axial load (dynamic)	N	0.2
27_	Max. force for press fits (static)	N	10
	(static, shaft supported)	N	10
28_	Max. radial load [mm from flange]	N	2 [2]

**Other specifications**

29_	Number of pole pairs	1	
30_	Number of phases	3	
31_	Weight of motor	g	6
32_	Typical noise level [rpm]	dB(A)	49 [50 000]

**maxon Modular System**

<b>maxon gear</b>	Stages	<b>maxon sensor</b>	<b>maxon motor control</b>
56_GPX 8 A	1-5	for motor type B: 80_ENX 8 81_ENX 8 Abs.	378_ESCON Module 24/2 379_ESCON 36/3 EC 379_ESCON Module 50/4 EC-S 382_DEC Module 24/2 386_EPOS2 24/2 386_EPOS2 Module 36/2

**Connection A** (flat band cable AWG 28, pitch 1.27 mm)

- Pin 1 Motor winding 1
  - Pin 2 Motor winding 2
  - Pin 3 Motor winding 3
  - Pin 4 V<sub>Hall</sub> 1.6...5.5 VDC
  - Pin 5 GND
  - Pin 6 Hall sensor 1
  - Pin 7 Hall sensor 2
  - Pin 8 Hall sensor 3
- Output signal: CMOS compatible  
Output current per channel: max 0.5 mA

**Connection B** (flat band cable AWG 28, pitch 1.27 mm)

- Pin 1 Motor winding 1
- Pin 2 Motor winding 2
- Pin 3 Motor winding 3
- Pin 4 N.C.

**Configuration**

Shaft front: length  
Electric connection: cable length  
Cable insulation: PVC/PO/FEP

**Notes**

<sup>1</sup> For type A:  
PVC-cable (-20...85°C)  
PO- and FEP cable (-30...85°C)  
For type B:  
PVC-cable (-20...100°C)  
PO- and FEP cable (-40...100°C)

Adapter Micromotor (Part number 498157) required for all maxon controllers.



# ECX SPEED 8 M brushless

BLDC motor Ø8 mm

High Power

**NEW**

3/6.0 W 1.24 mNm 50000 rpm

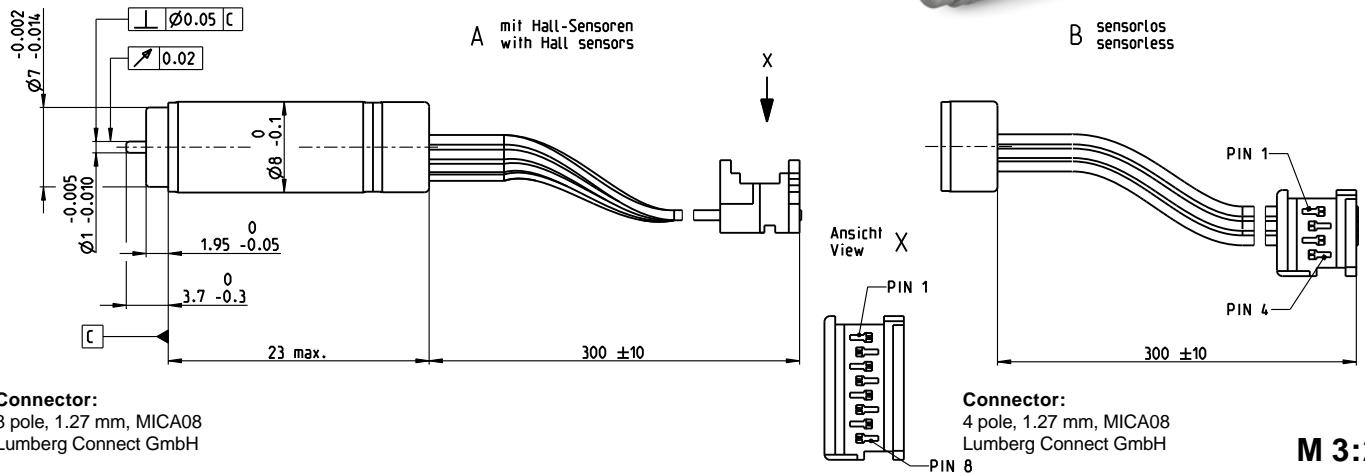

**M 3:2**

### Motor Data

1_	Nominal voltage	V	6	9	12
2_	No load speed	rpm	37900	31400	33000
3_	No load current	mA	88.2	43.4	35.2
4_	Nominal speed	rpm	28000	22500	24300
5_	Nominal torque (max. continuous torque)	mNm	1.24	1.24	1.24
6_	Nominal current (max. continuous current)	A	0.913	0.5	0.393
7_	Stall torque	mNm	4.91	4.53	4.85
8_	Stall current	A	3.34	1.7	1.43
9_	Max. efficiency	%	71	71	72
10_	Terminal resistance	Ω	1.8	5.3	8.38
11_	Terminal inductance	mH	0.0264	0.0888	0.144
12_	Torque constant	mNm/A	1.47	2.67	3.39
13_	Speed constant	rpm/V	6500	3580	2820
14_	Speed/torque gradient	rpm/mNm	7940	7110	6980
15_	Mechanical time constant	ms	2.08	1.73	1.69
16_	Rotor inertia	gcm <sup>2</sup>	0.025	0.025	0.025

### Thermal data

17_	Thermal resistance housing-ambient	K/W	51.2
18_	Thermal resistance winding-housing	K/W	4.11
19_	Thermal time constant winding	s	0.906
20_	Thermal time constant motor	s	154
21_	Ambient temperature <sup>1</sup>	°C	-20...+85
22_	Max. winding temperature	°C	125

### Operating Range

n [rpm] Winding 9 V

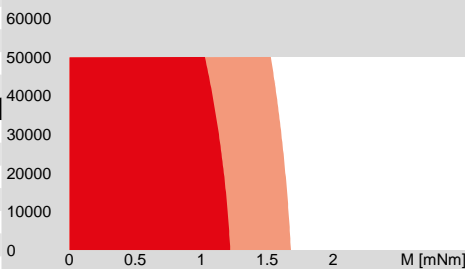

■ Continuous operation  
■ Continuous operation with reduced thermal resistance R<sub>m2</sub> 50%  
□ Short term operation

### Mechanical data ball bearings

23_	Max. speed	rpm	50000
24_	Axial play	mm	0...0.07
	Preload	N	0.3
	Direction of force		pull
25_	Radial play		preloaded
26_	Max. axial load (dynamic)	N	0.2
27_	Max. force for press fits (static) (static, shaft supported)	N	10
28_	Max. radial load [mm from flange]	N	2 [2]

### Other specifications

29_	Number of pole pairs	1	
30_	Number of phases	3	
31_	Weight of motor	g	6
32_	Typical noise level [rpm]	dBA	49 [50000]

### maxon Modular System

<b>maxon gear</b>	Stages	<b>maxon sensor</b>	<b>maxon motor control</b>
56_GPX 8 A	1-5	for motor type B: 80_ENX 8 81_ENX 8 Abs.	378_ESCON Module 24/2 379_ESCON 36/3 EC 379_ESCON Module 50/4 EC-S 382_DEC Module 24/2 386_EPOS2 24/2 386_EPOS2 Module 36/2

### Connection A (flat band cable AWG 28, pitch 1.27 mm)

Pin 1	Motor winding 1
Pin 2	Motor winding 2
Pin 3	Motor winding 3
Pin 4	V <sub>Hall</sub> 1.6...5.5 VDC
Pin 5	GND
Pin 6	Hall sensor 1
Pin 7	Hall sensor 2
Pin 8	Hall sensor 3
Output signal: CMOS compatible	
Output current per channel: max 0.5 mA	

### Connection B (flat band cable AWG 28, pitch 1.27 mm)

Pin 1	Motor winding 1
Pin 2	Motor winding 2
Pin 3	Motor winding 3
Pin 4	N.C.

### Configuration

Shaft front: length  
Electric connection: cable length  
Cable insulation: PVC/PO/FEP

### Notes

<sup>1</sup> For type A:  
PVC-cable (-20...85°C)  
PO- and FEP cable (-30...85°C)  
For type B:  
PVC-cable (-20...100°C)  
PO- and FEP cable (-40...100°C)

Adapter Micromotor (Part number 498157) required for all maxon controllers.

xdrives.maxonmotor.com

# ECX SPEED 16 M brushless

BLDC motor Ø16 mm

Sterilizable

**NEW**



40/51 W 6.6 mNm 70000 rpm

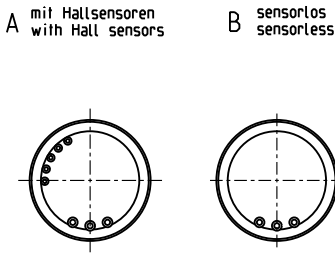

Lage des Kabelabganges zum Befestigungsbohrbild ±25°  
alignment of cables relative to mounting holes ±25°

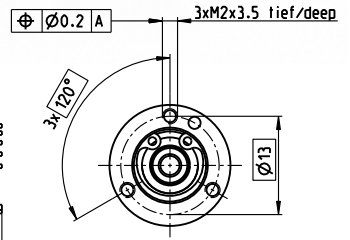
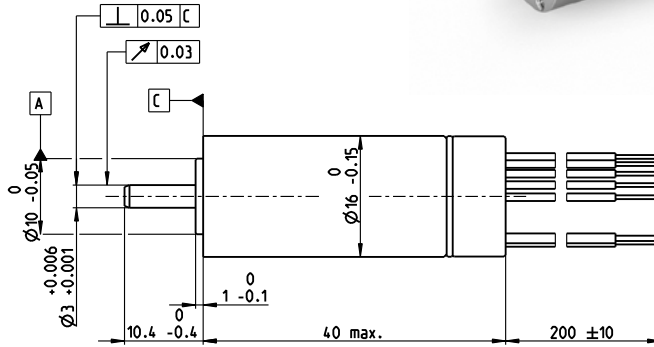

M 1:1

**Motor Data**

1_	Nominal voltage	V	18	24	48
2_	No load speed	rpm	61500	65000	58900
3_	No load current	mA	275	227	96.2
4_	Nominal speed	rpm	56400	59900	53900
5_	Nominal torque (max. continuous torque)	mNm	6.88	6.61	6.64
6_	Nominal current (max. continuous current)	A	2.71	2.08	0.94
7_	Stall torque	mNm	97.3	99.6	91
8_	Stall current	A	35.1	28.5	11.8
9_	Max. efficiency	%	84	83	83
10_	Terminal resistance	Ω	0.512	0.841	4.06
11_	Terminal inductance	mH	0.0341	0.0542	0.264
12_	Torque constant	mNm/A	2.77	3.49	7.7
13_	Speed constant	rpm/V	3450	2740	1240
14_	Speed/torque gradient	rpm/mNm	638	659	654
15_	Mechanical time constant	ms	3.94	4.06	4.03
16_	Rotor inertia	gcm <sup>2</sup>	0.589	0.589	0.589

**Thermal data**

17_	Thermal resistance housing-ambient	K/W	20.2
18_	Thermal resistance winding-housing	K/W	1.64
19_	Thermal time constant winding	s	1.97
20_	Thermal time constant motor	s	505
21_	Ambient temperature	°C	-40...+135
22_	Max. winding temperature	°C	155

**Operating Range**

n [rpm] winding 24 V

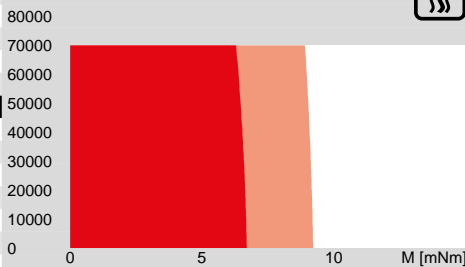

Sensorless: typical 2000 sterilization cycles  
Hall sensors: typical 1000 sterilization cycles  
Sterilization with steam  
Temperature +134°C ±4°C  
Compression pressure up to 2.3 bar  
Rel. humidity 100%  
Cycle length 18 min.

**Mechanical data ball bearings**

23_	Max. speed	rpm	70000
24_	Axial play	mm	0..0.29
	Preload	N	2.5
	Direction of force		pull
25_	Radial play	preloaded	
26_	Max. axial load (dynamic)	N	2.5
27_	Max. force for press fits (static)	N	60
	(static, shaft supported)	N	2500
28_	Max. radial load [mm from flange]	N	10 [5]

**Other specifications**

29_	Number of pole pairs		1
30_	Number of phases		3
31_	Weight of motor	g	50
32_	Typical noise level [rpm]	dBA	50 [50000]

**maxon Modular System**

maxon gear	Stages	maxon sensor	maxon motor control
65_GPX 16 SPEED	1-2		378_ESCON Module 24/2 379_ESCON 36/3 EC 379_ESCON Module 50/4 EC-S 379_ESCON Module 50/5 382_DEC Module 24/2 382_DEC Module 50/5

**Connection A and B, motor (Cable AWG 22)**

red	Motor winding 1
black	Motor winding 2
white	Motor winding 3

**Connection A, sensors (Cable AWG 26)**

orange	V <sub>Hall</sub> 3...24 VDC
blue	GND
yellow	Hall sensor 1
brown	Hall sensor 2
grey	Hall sensor 3

Wiring diagram for Hall sensors see page 33

**Connection NTC (Cable AWG 26)**

purple	NTC
purple	NTC
Resistance 25°C: 10 kOhm ±1%, beta (25-85°C): 3490 K	

**Configuration**

Flange front: thread in flange/center thread  
Flange back: without/center thread  
Shaft front: length  
Electric connection: cable length/pin connection  
Temperature Sensor: NTC-Thermistor

# ECX SPEED 16 M brushless

**NEW**

BLDC motor Ø16 mm

Sterilizable, Ceramic Bearings



40/72.4 W 6.6 mNm 120 000 rpm

A mit Hallsensoren  
with Hall sensors

B sensorlos  
sensorless

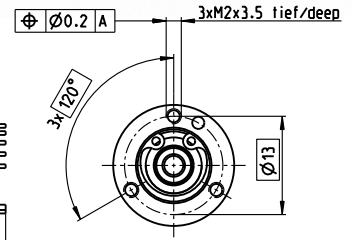
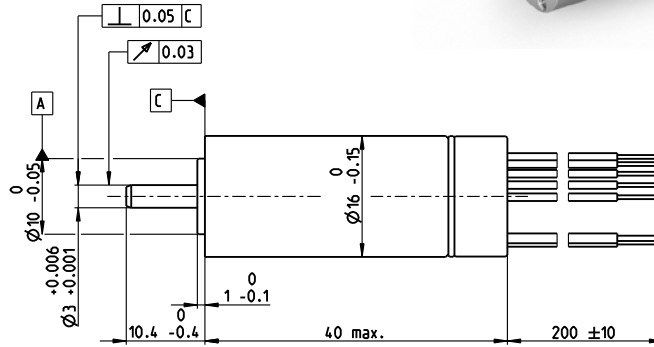
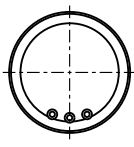
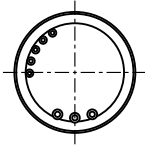

Lage des Kabelabganges  
zum Befestigungsbohrbild ±25°

alignment of cables relative  
to mounting holes ±25°

**M 1:1**

### Motor Data

1_	Nominal voltage	V	18	24	48
2_	No load speed	rpm	61500	65000	58900
3_	No load current	mA	275	227	96.2
4_	Nominal speed	rpm	56400	59900	53900
5_	Nominal torque (max. continuous torque)	mNm	6.88	6.61	6.64
6_	Nominal current (max. continuous current)	A	2.71	2.08	0.94
7_	Stall torque	mNm	97.3	99.6	91
8_	Stall current	A	35.1	28.5	11.8
9_	Max. efficiency	%	84	83	83
10_	Terminal resistance	Ω	0.512	0.841	4.06
11_	Terminal inductance	mH	0.0341	0.0542	0.264
12_	Torque constant	mNm/A	2.77	3.49	7.7
13_	Speed constant	rpm/V	3450	2740	1240
14_	Speed/torque gradient	rpm/mNm	638	659	654
15_	Mechanical time constant	ms	3.94	4.06	4.03
16_	Rotor inertia	gcm <sup>2</sup>	0.589	0.589	0.589

### Thermal data

17_	Thermal resistance housing-ambient	K/W	20.2
18_	Thermal resistance winding-housing	K/W	1.64
19_	Thermal time constant winding	s	1.97
20_	Thermal time constant motor	s	505
21_	Ambient temperature	°C	-40...+135
22_	Max. winding temperature	°C	155

### Operating Range

n [rpm] winding 24 V

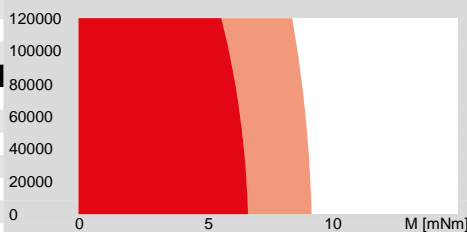

Sensorless: typical 2000 sterilization cycles  
Hall sensors: typical 1000 sterilization cycles  
Sterilization with steam  
Temperature +134°C ±4°C  
Compression pressure up to 2.3 bar  
Rel. humidity 100%  
Cycle length 18 min.

### Mechanical data ball bearings

23_	Max. speed	rpm	120 000
24_	Axial play	mm	0..0.29
	Preload	N	2.5
	Direction of force		pull
25_	Radial play		preloaded
26_	Max. axial load (dynamic)	N	2.5
27_	Max. force for press fits (static)	N	60
	(static, shaft supported)	N	2500
28_	Max. radial load [mm from flange]	N	10 [5]

### Other specifications

29_	Number of pole pairs		1
30_	Number of phases		3
31_	Weight of motor	g	50
32_	Typical noise level [rpm]	dBA	50 [50000]

### Connection A and B, motor (Cable AWG 22)

red	Motor winding 1
black	Motor winding 2
white	Motor winding 3

### Connection A, sensors (Cable AWG 26)

orange	V <sub>Hall</sub> 3...24 VDC
blue	GND
yellow	Hall sensor 1
brown	Hall sensor 2
grey	Hall sensor 3

Wiring diagram for Hall sensors see page 33

### Connection NTC (Cable AWG 26)

purple	NTC
purple	NTC

Resistance 25°C: 10 kOhm ±1%, beta (25–85°C): 3490 K

### maxon Modular System

maxon gear	Stages	maxon sensor	maxon motor control
65_GPX 16 SPEED	1–2		378_ESCON Module 24/2
			379_ESCON 36/3 EC
			379_ESCON Module 50/4 EC-S
			379_ESCON Module 50/5
			379_ESCON 50/5
			382_DEC Module 24/2
			382_DEC Module 50/5

### Configuration

Flange front: thread in flange/center thread  
Flange back: without/center thread  
Shaft front: length  
Electric connection: cable length/pin connection  
Temperature Sensor: NTC-Thermistor

xdrives.maxonmotor.com

# ECX SPEED 16 L brushless

## BLDC motor Ø16 mm

**NEW**

Sterilizable



80/97 W 13.9 mNm 70000 rpm

A mit Hallensoren  
with Hall sensors

B sensorlos  
sensorless

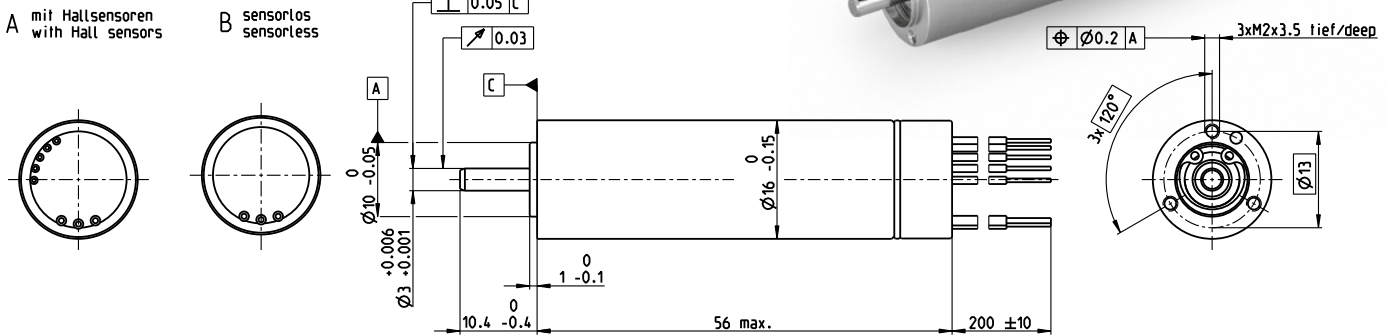

Lage des Kabelabganges  
zum Befestigungsbohrbild ±25°

alignment of cables relative  
to mounting holes ±25°

**M 1:1**

**Motor Data**

1_	Nominal voltage	V	18	24	36	48
2_	No load speed	rpm	67700	67700	67700	67700
3_	No load current	mA	567	425	283	213
4_	Nominal speed	rpm	64600	64900	65100	65100
5_	Nominal torque (max. continuous torque)	mNm	13.4	13.9	13.4	12.8
6_	Nominal current (max. continuous current)	A	5.82	4.52	2.9	2.1
7_	Stall torque	mNm	330	389	395	377
8_	Stall current	A	131	115	78.1	56
9_	Max. efficiency	%	88	89	89	88
10_	Terminal resistance	Ω	0.138	0.208	0.461	0.858
11_	Terminal inductance	mH	0.00567	0.0101	0.0227	0.0403
12_	Torque constant	mNm/A	2.53	3.37	5.06	6.74
13_	Speed constant	rpm/V	3780	2830	1890	1420
14_	Speed/torque gradient	rpm/mNm	206	175	172	180
15_	Mechanical time constant	ms	1.24	1.06	1.04	1.09
16_	Rotor inertia	gcm <sup>2</sup>	0.577	0.577	0.577	0.577

**Thermal data**

17_	Thermal resistance housing-ambient	K/W	15.8
18_	Thermal resistance winding-housing	K/W	0.952
19_	Thermal time constant winding	s	1.88
20_	Thermal time constant motor	s	574
21_	Ambient temperature	°C	-40...+135
22_	Max. winding temperature	°C	155

**Operating Range**

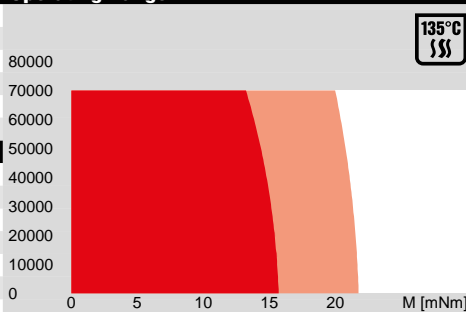

Sensorless: typical 2000 sterilization cycles  
Hall sensors: typical 1000 sterilization cycles  
Sterilization with steam  
Temperature +134°C ±4°C  
Compression pressure up to 2.3 bar  
Rel. humidity 100%  
Cycle length 18 min.

■ Continuous operation  
■ Continuous operation with reduced thermal resistance R<sub>th2</sub> 50%  
□ Short term operation

**Mechanical data ball bearings**

23_	Max. speed	rpm	70000
24_	Axial play	mm	0...0.29
	Preload	N	2.5
	Direction of force		pull
25_	Radial play		preloaded
26_	Max. axial load (dynamic)	N	2.5
27_	Max. force for press fits (static)	N	60
	(static, shaft supported)	N	2500
28_	Max. radial load [mm from flange]	N	10 [5]

**Other specifications**

29_	Number of pole pairs		1
30_	Number of phases		3
31_	Weight of motor	g	73
32_	Typical noise level [rpm]	dBA	52 [50000]

**maxon Modular System**

<b>maxon gear</b>	<b>Stages</b>	<b>maxon sensor</b>	<b>maxon motor control</b>
65_GPX 16 SPEED	1-2		379_ESCON 36/3 EC 379_ESCON Module 50/4 EC-S 379_ESCON Module 50/5 379_ESCON 50/5 379_ESCON 70/10 382_DEC Module 50/5

**Connection A and B, motor (Cable AWG 22)**

red Motor winding 1  
black Motor winding 2  
white Motor winding 3

**Connection A, sensors (Cable AWG 26)**

orange V<sub>Hall</sub> 3...24 VDC  
blue GND  
yellow Hall sensor 1  
brown Hall sensor 2  
grey Hall sensor 3

Wiring diagram for Hall sensors see page 33

**Connection NTC (Cable AWG 26)**

purple NTC  
purple NTC  
Resistance 25°C: 10 kOhm ±1%, beta (25-85°C): 3490 K

**Configuration**

Flange front: thread in flange/center thread  
Flange back: without/center thread  
Shaft front: length  
Electric connection: cable length/pin connection  
Temperature Sensor: NTC-Thermistor



# ECX SPEED 16 L brushless

## BLDC motor Ø16 mm

Sterilizable, Ceramic Bearings

**NEW**

80/104 W 13.9 mNm 120 000 rpm

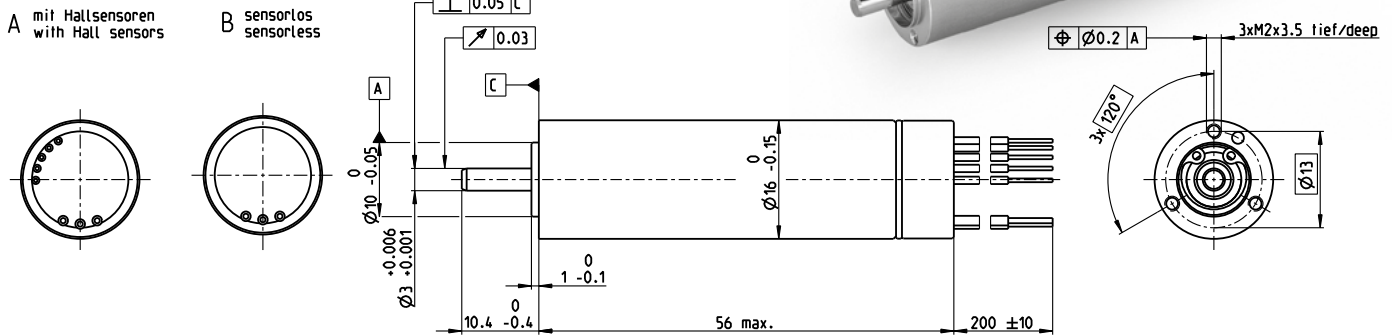

Lage des Kabelabganges zum Befestigungsbohrbild ±25°

alignment of cables relative to mounting holes ±25°

**M 1:1**

### Motor Data

1_	Nominal voltage	V	18	24	36	48
2_	No load speed	rpm	67700	67700	67700	67700
3_	No load current	mA	567	425	283	213
4_	Nominal speed	rpm	64600	64900	65100	65100
5_	Nominal torque (max. continuous torque)	mNm	13.4	13.9	13.4	12.8
6_	Nominal current (max. continuous current)	A	5.82	4.52	2.9	2.1
7_	Stall torque	mNm	330	389	395	377
8_	Stall current	A	131	115	78.1	56
9_	Max. efficiency	%	88	89	89	88
10_	Terminal resistance	Ω	0.138	0.208	0.461	0.858
11_	Terminal inductance	mH	0.00567	0.0101	0.0227	0.0403
12_	Torque constant	mNm/A	2.53	3.37	5.06	6.74
13_	Speed constant	rpm/V	3780	2830	1890	1420
14_	Speed/torque gradient	rpm/mNm	206	175	172	180
15_	Mechanical time constant	ms	1.24	1.06	1.04	1.09
16_	Rotor inertia	gcm <sup>2</sup>	0.577	0.577	0.577	0.577

### Thermal data

17_	Thermal resistance housing-ambient	K/W	15.8
18_	Thermal resistance winding-housing	K/W	0.952
19_	Thermal time constant winding	s	1.88
20_	Thermal time constant motor	s	574
21_	Ambient temperature	°C	-40...+135
22_	Max. winding temperature	°C	155

### Operating Range

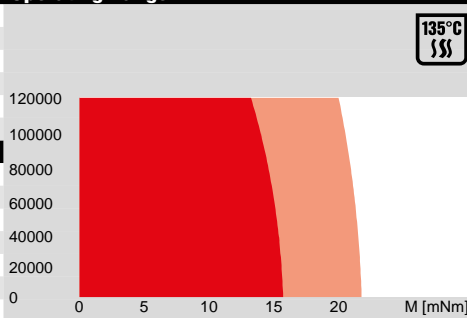

Sensorless: typical 2000 sterilization cycles  
Hall sensors: typical 1000 sterilization cycles  
Sterilization with steam  
Temperature +134°C ±4°C  
Compression pressure up to 2.3 bar  
Rel. humidity 100%  
Cycle length 18 min.

■ Continuous operation  
■ Continuous operation with reduced thermal resistance R<sub>th2</sub> 50%  
□ Short term operation

### Mechanical data ball bearings

23_	Max. speed	rpm	120 000
24_	Axial play	mm	0...0.29
	Preload	N	2.5
	Direction of force		pull
25_	Radial play		preloaded
26_	Max. axial load (dynamic)	N	2.5
27_	Max. force for press fits (static) (static, shaft supported)	N	60
28_	Max. radial load [mm from flange]	N	10 [5]

### Other specifications

29_	Number of pole pairs		1
30_	Number of phases		3
31_	Weight of motor	g	73
32_	Typical noise level [rpm]	dBA	52 [50 000]

### Connection A and B, motor (Cable AWG 22)

red Motor winding 1  
black Motor winding 2  
white Motor winding 3

### Connection A, sensors (Cable AWG 26)

orange V<sub>Hall</sub> 3...24 VDC  
blue GND  
yellow Hall sensor 1  
brown Hall sensor 2  
grey Hall sensor 3

Wiring diagram for Hall sensors see page 33

### Connection NTC (Cable AWG 26)

purple NTC  
purple NTC  
Resistance 25°C: 10 kOhm ±1%, beta (25–85°C): 3490 K

### maxon Modular System

maxon gear	Stages	maxon sensor	maxon motor control
65_GPX 16 SPEED	1–2		379_ESCON 36/3 EC 379_ESCON Module 50/4 EC-S 379_ESCON Module 50/5 379_ESCON 50/5 379_ESCON 70/10 382_DEC Module 50/5

### Configuration

Flange front: thread in flange/center thread  
Flange back: without/center thread  
Shaft front: length  
Electric connection: cable length/pin connection  
Temperature Sensor: NTC-Thermistor

xdrives.maxonmotor.com

# ECX SPEED 19 M brushless BLDC motor Ø19 mm

Sterilizable

**NEW**



60/68 W 10.3 mNm 70000 rpm

A mit Hallensoren  
with Hall sensors

B sensorlos  
sensorless

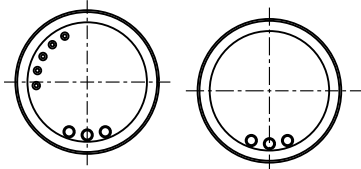

Lage des Kabelabganges  
zum Befestigungsbohrbild ±25°

alignment of cables relative  
to mounting holes ±25°

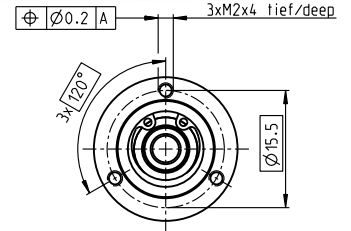
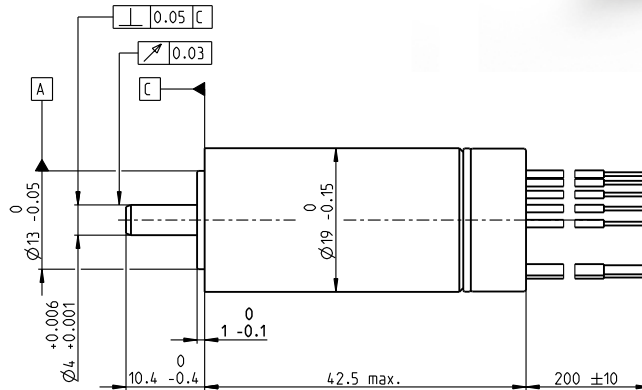

M 1:1

### Motor Data

1_ Nominal voltage	V	18	24	36	48
2_ No load speed	rpm	64700	64400	64500	63300
3_ No load current	mA	307	229	153	112
4_ Nominal speed	rpm	59700	59300	59700	58600
5_ Nominal torque (max. continuous torque)	mNm	10.7	9.59	9.91	10.1
6_ Nominal current (max. continuous current)	A	4.28	2.89	1.99	1.49
7_ Stall torque	mNm	175	150	164	169
8_ Stall current	A	66.1	42.4	31	23.5
9_ Max. efficiency	%	87	86	87	87
10_ Terminal resistance	Ω	0.272	0.566	1.16	2.04
11_ Terminal inductance	mH	0.0234	0.0438	0.0986	0.182
12_ Torque constant	mNm/A	2.64	3.54	5.3	7.2
13_ Speed constant	rpm/V	3610	2700	1800	1330
14_ Speed/torque gradient	rpm/mNm	373	432	396	376
15_ Mechanical time constant	ms	4.49	5.2	4.77	4.53
16_ Rotor inertia	gcm <sup>2</sup>	1.15	1.15	1.15	1.15

### Thermal data

17_ Thermal resistance housing-ambient	K/W	16.9
18_ Thermal resistance winding-housing	K/W	1.1
19_ Thermal time constant winding	s	1.62
20_ Thermal time constant motor	s	700
21_ Ambient temperature	°C	-40...+135
22_ Max. winding temperature	°C	155

### Operating Range

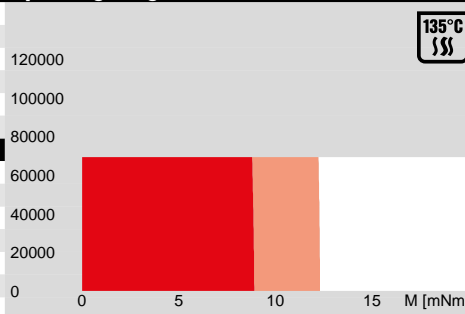

Sensorless: typical 2000 sterilization cycles  
Hall sensors: typical 1000 sterilization cycles  
Sterilization with steam  
Temperature +134°C ±4°C  
Compression pressure up to 2.3 bar  
Rel. humidity 100%  
Cycle length 18 min.

■ Continuous operation  
■ Continuous operation with reduced thermal resistance R<sub>th2</sub> 50%  
■ Short term operation

### Mechanical data ball bearings

23_ Max. speed	rpm	70000
24_ Axial play	mm	0...0.29
Preload	N	4
Direction of force	pull	
25_ Radial play	preloaded	
26_ Max. axial load (dynamic)	N	4
27_ Max. force for press fits (static)	N	70
(static, shaft supported)	N	5000
28_ Max. radial load [mm from flange]	N	12 [5]

### Other specifications

29_ Number of pole pairs		1
30_ Number of phases		3
31_ Weight of motor	g	78
32_ Typical noise level [rpm]	dBA	48 [50 000]

### Connection A and B, motor (Cable AWG 20)

red Motor winding 1  
black Motor winding 2  
white Motor winding 3

### Connection A, sensors (Cable AWG 26)

orange V<sub>Hall</sub> 3...24 VDC  
blue GND  
yellow Hall sensor 1  
brown Hall sensor 2  
grey Hall sensor 3

Wiring diagram for Hall sensors see page 33

### Connection NTC (Cable AWG 26)

purple NTC  
purple NTC  
Resistance 25°C: 10 kOhm ±1%, beta (25–85°C): 3490 K

### maxon Modular System

maxon gear	maxon sensor	maxon motor control
		379_ESCON 36/3 EC
		379_ESCON Module 50/4 EC-S
		379_ESCON Module 50/5
		379_ESCON 50/5
		382_DEC Module 50/5

### Configuration

Flange front: thread in flange/center thread  
Flange back: without/center thread  
Shaft front: length  
Electric connection: cable length/pin connection  
Temperature Sensor: NTC-Thermistor

# ECX SPEED 19 M brushless

## BLDC motor Ø19 mm

Sterilizable, Ceramic Bearings

**NEW**

60/94 W 10.3 mNm 100000 rpm



A mit Hallensoren  
with Hall sensors

B sensorlos  
sensorless

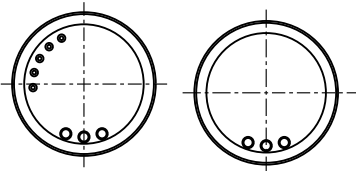

Lage des Kabelabganges  
zum Befestigungsbohrbild ±25°

alignment of cables relative  
to mounting holes ±25°

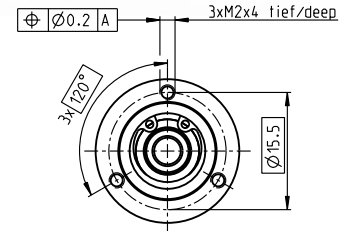
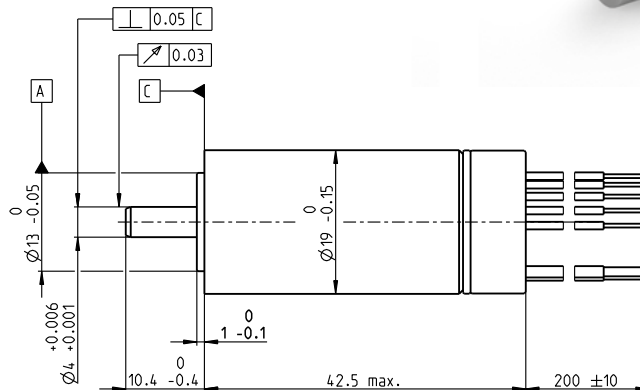

**M 1:1**

### Motor Data

1_	Nominal voltage	V	18	24	36	48
2_	No load speed	rpm	64700	64400	64500	63300
3_	No load current	mA	307	229	153	112
4_	Nominal speed	rpm	59700	59300	59700	58600
5_	Nominal torque (max. continuous torque)	mNm	10.7	9.59	9.91	10.1
6_	Nominal current (max. continuous current)	A	4.28	2.89	1.99	1.49
7_	Stall torque	mNm	175	150	164	169
8_	Stall current	A	66.1	42.4	31	23.5
9_	Max. efficiency	%	87	87	87	87
10_	Terminal resistance	Ω	0.272	0.566	1.16	2.04
11_	Terminal inductance	mH	0.0234	0.0438	0.0986	0.182
12_	Torque constant	mNm/A	2.64	3.54	5.3	7.2
13_	Speed constant	rpm/V	3610	2700	1800	1330
14_	Speed/torque gradient	rpm/mNm	373	432	396	376
15_	Mechanical time constant	ms	4.49	5.2	4.77	4.53
16_	Rotor inertia	gcm <sup>2</sup>	1.15	1.15	1.15	1.15

### Thermal data

17_	Thermal resistance housing-ambient	K/W	16.9
18_	Thermal resistance winding-housing	K/W	1.1
19_	Thermal time constant winding	s	1.62
20_	Thermal time constant motor	s	700
21_	Ambient temperature	°C	-40...+135
22_	Max. winding temperature	°C	155

### Operating Range

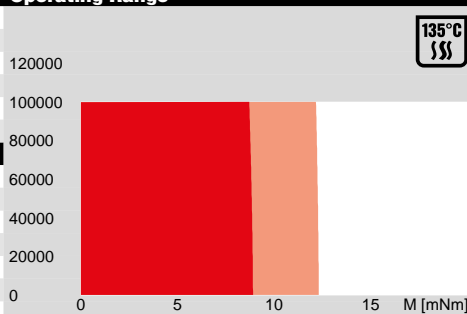

Sensorless: typical 2000 sterilization cycles  
Hall sensors: typical 1000 sterilization cycles  
Sterilization with steam  
Temperature +134°C ±4°C  
Compression pressure up to 2.3 bar  
Rel. humidity 100%  
Cycle length 18 min.

### Mechanical data ball bearings

23_	Max. speed	rpm	100000
24_	Axial play	mm	0...0.29
	Preload	N	4
	Direction of force		pull
25_	Radial play		preloaded
26_	Max. axial load (dynamic)	N	4
27_	Max. force for press fits (static)	N	70
	(static, shaft supported)	N	5000
28_	Max. radial load [mm from flange]	N	12 [5]

### Other specifications

29_	Number of pole pairs		1
30_	Number of phases		3
31_	Weight of motor	g	78
32_	Typical noise level [rpm]	dBA	48 [50000]

### Connection A and B, motor (Cable AWG 20)

red Motor winding 1  
black Motor winding 2  
white Motor winding 3

### Connection A, sensors (Cable AWG 26)

orange V<sub>Hall</sub> 3...24 VDC  
blue GND  
yellow Hall sensor 1  
brown Hall sensor 2  
grey Hall sensor 3

Wiring diagram for Hall sensors see page 33

### Connection NTC (Cable AWG 26)

purple NTC  
purple NTC  
Resistance 25°C: 10 kOhm ±1%, beta (25–85°C): 3490 K

### maxon Modular System

maxon gear	maxon sensor	maxon motor control
		379_ESCON 36/3 EC
		379_ESCON Module 50/4 EC-S
		379_ESCON Module 50/5
		379_ESCON 50/5
		382_DEC Module 50/5

### Configuration

Flange front: thread in flange/center thread  
Flange back: without/center thread  
Shaft front: length  
Electric connection: cable length/pin connection  
Temperature Sensor: NTC-Thermistor

xdrives.maxonmotor.com

# ECX SPEED 19 L brushless BLDC motor Ø19 mm

**NEW**

Sterilizable



120/145 W 22.7 mNm 70 000 rpm

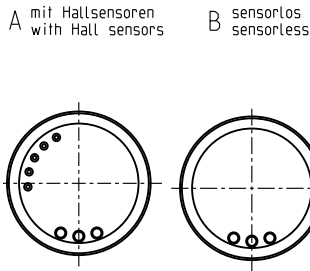

Lage des Kabelabganges zum Befestigungsbohrbild ±25°  
alignment of cables relative to mounting holes ±25°

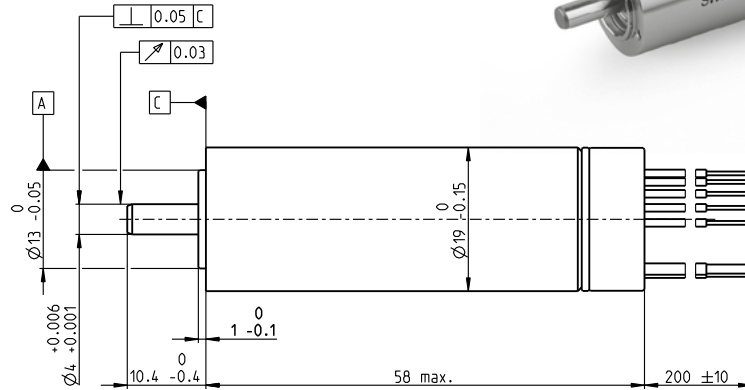

M 1:1

**Motor Data**

1_	Nominal voltage	V	18	24	36	48
2_	No load speed	rpm	60800	60800	57600	63400
3_	No load current	mA	426	319	194	172
4_	Nominal speed	rpm	57200	57600	54700	60500
5_	Nominal torque (max. continuous torque)	mNm	23.3	22.7	23.5	22.6
6_	Nominal current (max. continuous current)	A	8.56	6.27	4.09	3.27
7_	Stall torque	mNm	503	551	613	655
8_	Stall current	A	178	146	103	90.8
9_	Max. efficiency	%	91	91	91	92
10_	Terminal resistance	Ω	0.101	0.164	0.35	0.528
11_	Terminal inductance	mH	0.0096	0.0171	0.0428	0.0627
12_	Torque constant	mNm/A	2.82	3.76	5.95	7.21
13_	Speed constant	rpm/V	3390	2540	1600	1320
14_	Speed/torque gradient	rpm/mNm	121	111	94.2	97.1
15_	Mechanical time constant	ms	2.27	2.07	1.77	1.82
16_	Rotor inertia	gcm <sup>2</sup>	1.79	1.79	1.79	1.79

**Thermal data**

17_	Thermal resistance housing-ambient	K/W	14
18_	Thermal resistance winding-housing	K/W	0.9
19_	Thermal time constant winding	s	2.97
20_	Thermal time constant motor	s	580
21_	Ambient temperature	°C	-40...+135
22_	Max. winding temperature	°C	155

**Operating Range**

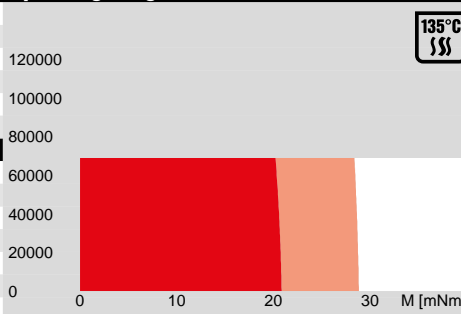

Sensorless: typical 2000 sterilization cycles  
Hall sensors: typical 1000 sterilization cycles  
Sterilization with steam  
Temperature +134°C ±4°C  
Compression pressure up to 2.3 bar  
Rel. humidity 100%  
Cycle length 18 min.

**Mechanical data ball bearings**

23_	Max. speed	rpm	70 000
24_	Axial play	mm	0...0.29
	Preload	N	4
	Direction of force		pull
25_	Radial play	preloaded	
26_	Max. axial load (dynamic)	N	4
27_	Max. force for press fits (static)	N	70
	(static, shaft supported)	N	5000
28_	Max. radial load [mm from flange]	N	12 [5]

**Other specifications**

29_	Number of pole pairs		1
30_	Number of phases		3
31_	Weight of motor	g	108
32_	Typical noise level [rpm]	dBA	51 [50 000]

**maxon Modular System**

maxon gear	maxon sensor	maxon motor control
		379_ESCON Module 50/4 EC-S
		379_ESCON Module 50/5
		379_ESCON 50/5
		379_ESCON 70/10
		382_DEC Module 50/5

**Connection A and B, motor (Cable AWG 20)**

red	Motor winding 1
black	Motor winding 2
white	Motor winding 3

**Connection A, sensors (Cable AWG 26)**

orange	V <sub>Hall</sub> 3...24 VDC
blue	GND
yellow	Hall sensor 1
brown	Hall sensor 2
grey	Hall sensor 3

Wiring diagram for Hall sensors see page 33

**Connection NTC (Cable AWG 26)**

purple	NTC
purple	NTC
Resistance 25°C: 10 kOhm ±1%, beta (25–85°C): 3490 K	

**Configuration**

Flange front: thread in flange/center thread  
Flange back: without/center thread  
Shaft front: length  
Electric connection: cable length/pin connection  
Temperature Sensor: NTC-Thermistor



# ECX SPEED 19 L brushless

## BLDC motor Ø19 mm

Sterilizable, Ceramic Bearings

**NEW**

120/200 W 22.7 mNm 100 000 rpm

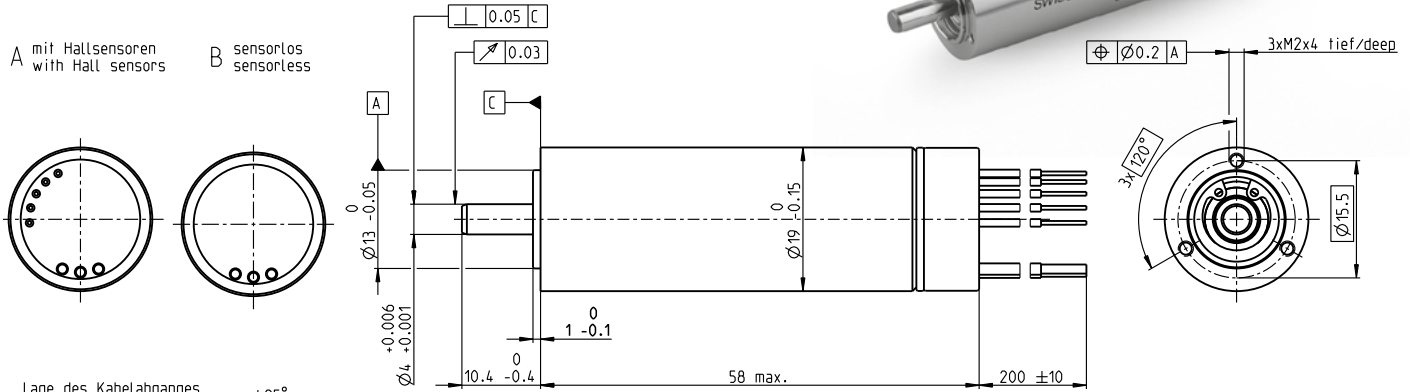

Lage des Kabelabganges zum Befestigungsbohrbild ±25°

alignment of cables relative to mounting holes ±25°

**M 1:1**

### Motor Data

1_ Nominal voltage	V	18	24	36	48
2_ No load speed	rpm	60800	60800	57600	63400
3_ No load current	mA	426	319	194	172
4_ Nominal speed	rpm	57200	57600	54700	60500
5_ Nominal torque (max. continuous torque)	mNm	23.3	22.7	23.5	22.6
6_ Nominal current (max. continuous current)	A	8.56	6.27	4.09	3.27
7_ Stall torque	mNm	503	551	613	655
8_ Stall current	A	178	146	103	90.8
9_ Max. efficiency	%	91	91	91	92
10_ Terminal resistance	Ω	0.101	0.164	0.35	0.528
11_ Terminal inductance	mH	0.0096	0.0171	0.0428	0.0627
12_ Torque constant	mNm/A	2.82	3.76	5.95	7.21
13_ Speed constant	rpm/V	3390	2540	1600	1320
14_ Speed/torque gradient	rpm/mNm	121	111	94.2	97.1
15_ Mechanical time constant	ms	2.27	2.07	1.77	1.82
16_ Rotor inertia	gcm <sup>2</sup>	1.79	1.79	1.79	1.79

### Thermal data

17_ Thermal resistance housing-ambient	K/W	14
18_ Thermal resistance winding-housing	K/W	0.9
19_ Thermal time constant winding	s	2.97
20_ Thermal time constant motor	s	580
21_ Ambient temperature	°C	-40...+135
22_ Max. winding temperature	°C	155

### Operating Range

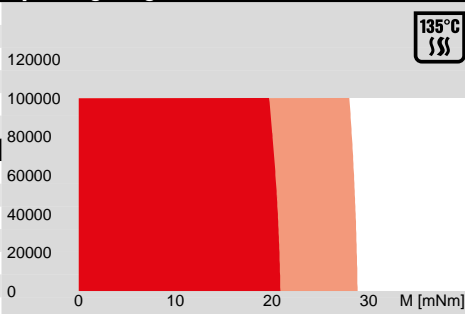

Sensorless: typical 2000 sterilization cycles  
Hall sensors: typical 1000 sterilization cycles  
Sterilization with steam  
Temperature +134°C ±4°C  
Compression pressure up to 2.3 bar  
Rel. humidity 100%  
Cycle length 18 min.

### Mechanical data ball bearings

23_ Max. speed	rpm	100 000
24_ Axial play	mm	0...0.29
Preload	N	4
Direction of force		pull
25_ Radial play		preloaded
26_ Max. axial load (dynamic)	N	4
27_ Max. force for press fits (static) (static, shaft supported)	N	70
28_ Max. radial load [mm from flange]	N	5000
		12 [5]

### Other specifications

29_ Number of pole pairs		1
30_ Number of phases		3
31_ Weight of motor	g	108
32_ Typical noise level [rpm]	dBA	51 [50000]

### Connection A and B, motor (Cable AWG 20)

red Motor winding 1  
black Motor winding 2  
white Motor winding 3

### Connection A, sensors (Cable AWG 26)

orange V<sub>Hall</sub> 3...24 VDC  
blue GND  
yellow Hall sensor 1  
brown Hall sensor 2  
grey Hall sensor 3

Wiring diagram for Hall sensors see page 33

### Connection NTC (Cable AWG 26)

purple NTC  
purple NTC  
Resistance 25°C: 10 kOhm ±1%, beta (25–85°C): 3490 K

### maxon Modular System

maxon gear

maxon sensor

maxon motor control

379\_ESCON Module 50/4 EC-S  
379\_ESCON Module 50/5  
379\_ESCON 50/5  
379\_ESCON 70/10  
382\_DEC Module 50/5

### Configuration

Flange front: thread in flange/center thread  
Flange back: without/center thread  
Shaft front: length  
Electric connection: cable length/pin connection  
Temperature Sensor: NTC-Thermistor

xdrives.maxonmotor.com

# ECX SPEED 22 M brushless BLDC motor Ø22 mm

**NEW**

Sterilizable



**80/106 W 19.5 mNm 60000 rpm**

A mit Hallensoren  
with Hall sensors      B sensorlos  
sensorless

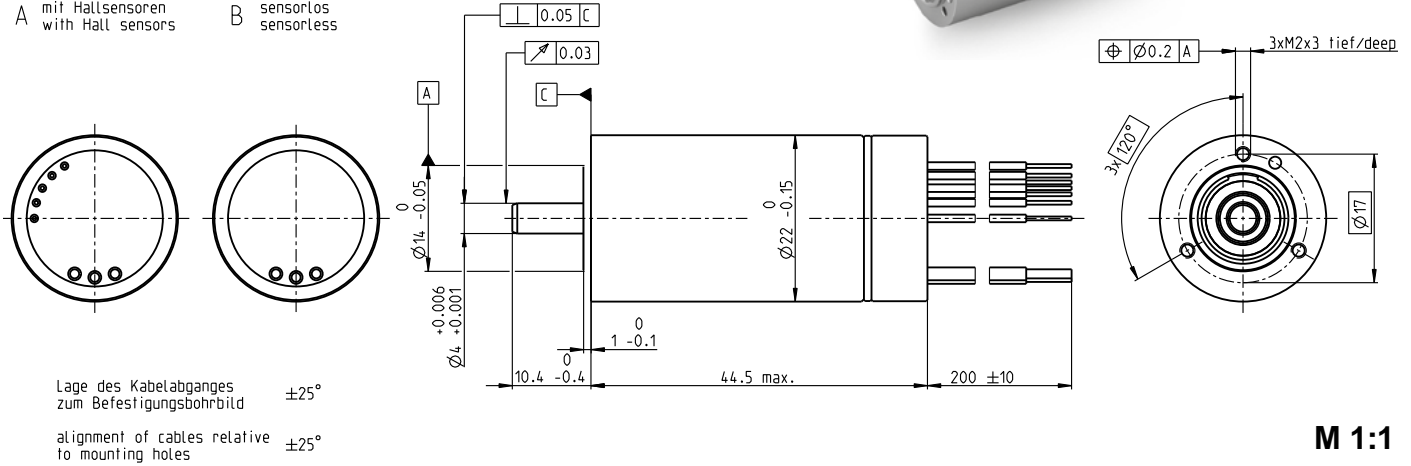

**M 1:1**

**Motor Data**

1_	Nominal voltage	V	18	24	36	48
2_	No load speed	rpm	52800	54800	56900	54800
3_	No load current	mA	286	227	161	114
4_	Nominal speed	rpm	49400	51500	53600	51500
5_	Nominal torque (max. continuous torque)	mNm	19.5	19.4	18.7	19
6_	Nominal current (max. continuous current)	A	6.23	4.85	3.23	2.37
7_	Stall torque	mNm	340	365	362	361
8_	Stall current	A	105	87.5	60.1	43.3
9_	Max. efficiency	%	90	90	90	90
10_	Terminal resistance	Ω	0.172	0.274	0.599	1.11
11_	Terminal inductance	mH	0.00934	0.0154	0.0322	0.0617
12_	Torque constant	mNm/A	3.24	4.17	6.02	8.34
13_	Speed constant	rpm/V	2940	2290	1590	1150
14_	Speed/torque gradient	rpm/mNm	156	151	158	152
15_	Mechanical time constant	ms	3.12	3.01	3.15	3.05
16_	Rotor inertia	gcm <sup>2</sup>	1.91	1.91	1.91	1.91

**Thermal data**

17_	Thermal resistance housing-ambient	K/W	12
18_	Thermal resistance winding-housing	K/W	1
19_	Thermal time constant winding	s	2.09
20_	Thermal time constant motor	s	334
21_	Ambient temperature	°C	-40...+135
22_	Max. winding temperature	°C	155

**Operating Range**

n [rpm] winding 36 V

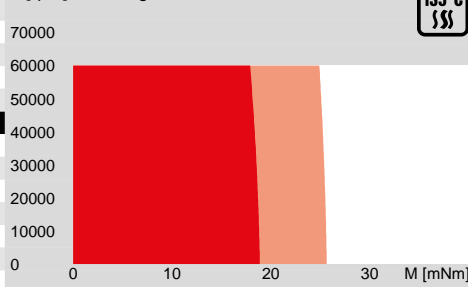

Sensorless: typical 2000 sterilization cycles  
Hall sensors: typical 1000 sterilization cycles  
Sterilization with steam  
Temperature +134°C ±4°C  
Compression pressure up to 2.3 bar  
Rel. humidity 100%  
Cycle length 18 min.

**Mechanical data ball bearings**

23_	Max. speed	rpm	60000
24_	Axial play	mm	0...0.24
	Preload	N	4
	Direction of force		pull
25_	Radial play		preloaded
26_	Max. axial load (dynamic)	N	4
27_	Max. force for press fits (static)	N	110
	(static, shaft supported)	N	6000
28_	Max. radial load [mm from flange]	N	16 [5]

**Other specifications**

29_	Number of pole pairs		1
30_	Number of phases		3
31_	Weight of motor	g	106
32_	Typical noise level [rpm]	dBA	54 [50000]

**maxon Modular System**

maxon gear	maxon sensor	maxon motor control
		379_ESCON Module 50/4 EC-S
		379_ESCON Module 50/5
		379_ESCON 50/5
		379_ESCON 70/10
		382_DEC Module 50/5

**Connection A and B, motor (Cable AWG 18)**

red	Motor winding 1
black	Motor winding 2
white	Motor winding 3

**Connection A, sensors (Cable AWG 26)**

orange	V <sub>Hall</sub> 3...24 VDC
blue	GND
yellow	Hall sensor 1
brown	Hall sensor 2
grey	Hall sensor 3

Wiring diagram for Hall sensors see page 33

**Connection NTC (Cable AWG 26)**

purple	NTC
purple	NTC
Resistance 25°C: 10 kOhm ±1%, beta (25–85°C): 3490 K	

**Configuration**

Flange front: thread in flange/center thread  
Flange back: without/center thread  
Shaft front: length  
Electric connection: cable length/pin connection  
Temperature Sensor: NTC-Thermistor

# ECX SPEED 22 M brushless

## BLDC motor Ø22 mm

Sterilizable, Ceramic Bearings

**NEW**



**80/168 W 19.5 mNm 85000 rpm**

A mit Hallensoren  
with Hall sensors      B sensorlos  
sensorless

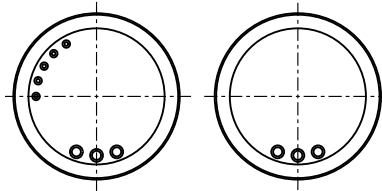

Lage des Kabelabganges  
zum Befestigungsbohrbild ±25°

alignment of cables relative  
to mounting holes ±25°

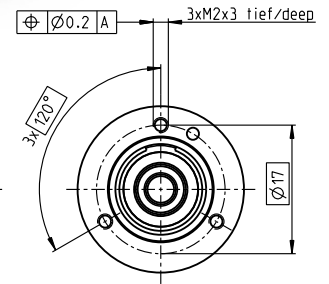
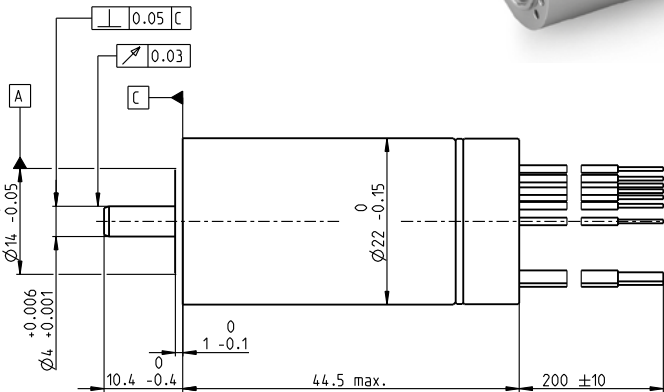

**M 1:1**

### Motor Data

1_	Nominal voltage	V	18	24	36	48
2_	No load speed	rpm	52800	54800	56900	54800
3_	No load current	mA	286	227	161	114
4_	Nominal speed	rpm	49400	51500	53600	51500
5_	Nominal torque (max. continuous torque)	mNm	19.5	19.9	18.7	19
6_	Nominal current (max. continuous current)	A	6.23	4.85	3.23	2.37
7_	Stall torque	mNm	340	365	362	361
8_	Stall current	A	105	87.5	60.1	43.3
9_	Max. efficiency	%	90	90	90	90
10_	Terminal resistance	Ω	0.172	0.274	0.599	1.11
11_	Terminal inductance	mH	0.00934	0.0154	0.0322	0.0617
12_	Torque constant	mNm/A	3.24	4.17	6.02	8.34
13_	Speed constant	rpm/V	2940	2290	1590	1150
14_	Speed/torque gradient	rpm/mNm	156	151	158	152
15_	Mechanical time constant	ms	3.12	3.01	3.15	3.05
16_	Rotor inertia	gcm <sup>2</sup>	1.91	1.91	1.91	1.91

### Thermal data

17_	Thermal resistance housing-ambient	K/W	12
18_	Thermal resistance winding-housing	K/W	1
19_	Thermal time constant winding	s	2.09
20_	Thermal time constant motor	s	334
21_	Ambient temperature	°C	-40...+135
22_	Max. winding temperature	°C	155

### Operating Range

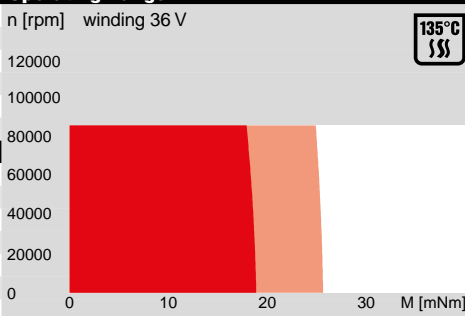

Sensorless: typical 2000 sterilization cycles  
Hall sensors: typical 1000 sterilization cycles  
Sterilization with steam  
Temperature +134°C ±4°C  
Compression pressure up to 2.3 bar  
Rel. humidity 100%  
Cycle length 18 min.

### Mechanical data ball bearings

23_	Max. speed	rpm	85000
24_	Axial play	mm	0...0.24
	Preload	N	4
	Direction of force		pull
25_	Radial play		preloaded
26_	Max. axial load (dynamic)	N	4
27_	Max. force for press fits (static)	N	110
	(static, shaft supported)	N	6000
28_	Max. radial load [mm from flange]	N	16 [5]

### Other specifications

29_	Number of pole pairs		1
30_	Number of phases		3
31_	Weight of motor	g	106
32_	Typical noise level [rpm]	dBA	54 [50000]

### Connection A and B, motor (Cable AWG 18)

red Motor winding 1  
black Motor winding 2  
white Motor winding 3

### Connection A, sensors (Cable AWG 26)

orange V<sub>Hall</sub> 3...24 VDC  
blue GND  
yellow Hall sensor 1  
brown Hall sensor 2  
grey Hall sensor 3

Wiring diagram for Hall sensors see page 33

### Connection NTC (Cable AWG 26)

purple NTC  
purple NTC  
Resistance 25°C: 10 kOhm ±1%, beta (25–85°C): 3490 K

### maxon Modular System

maxon gear	maxon sensor	maxon motor control
		379_ESCON Module 50/4 EC-S
		379_ESCON Module 50/5
		379_ESCON 50/5
		379_ESCON 70/10
		382_DEC Module 50/5

### Configuration

Flange front: thread in flange/center thread  
Flange back: without/center thread  
Shaft front: length  
Electric connection: cable length/pin connection  
Temperature Sensor: NTC-Thermistor

xdrives.maxonmotor.com

# ECX SPEED 22 L brushless BLDC motor Ø22 mm

Sterilizable

**NEW**



120/190 W 33 mNm 60000 rpm

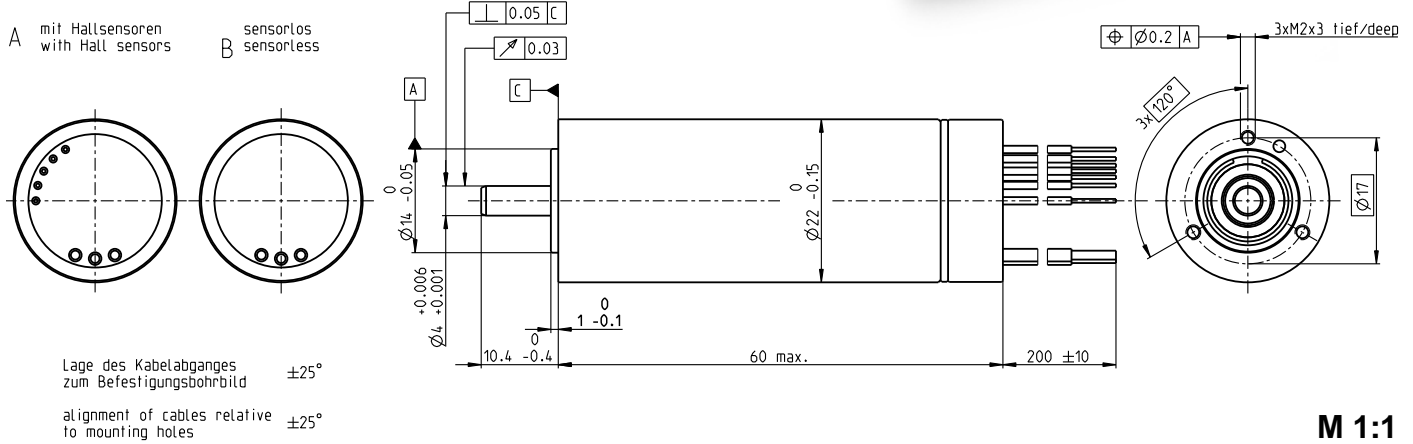

### Motor Data

1_ Nominal voltage	V	24	36	48
2_ No load speed	rpm	54100	56200	57300
3_ No load current	mA	425	303	235
4_ Nominal speed	rpm	51800	54000	55200
5_ Nominal torque (max. continuous torque)	mNm	32.6	33.5	31.6
6_ Nominal current (max. continuous current)	A	8.05	5.72	4.14
7_ Stall torque	mNm	965	1160	1120
8_ Stall current	A	228	190	140
9_ Max. efficiency	%	92	92	92
10_ Terminal resistance	Ω	0.105	0.189	0.343
11_ Terminal inductance	mH	0.0114	0.0237	0.0406
12_ Torque constant	mNm/A	4.23	6.11	7.99
13_ Speed constant	rpm/V	2260	1560	1200
14_ Speed/torque gradient	rpm/mNm	56.1	48.4	51.3
15_ Mechanical time constant	ms	1.39	1.2	1.27
16_ Rotor inertia	gcm <sup>2</sup>	2.36	2.36	2.36

### Thermal data

17_ Thermal resistance housing-ambient	K/W	10
18_ Thermal resistance winding-housing	K/W	0.823
19_ Thermal time constant winding	s	2.9
20_ Thermal time constant motor	s	507
21_ Ambient temperature	°C	-40...+135
22_ Max. winding temperature	°C	155

### Operating Range

n [rpm] winding 36 V

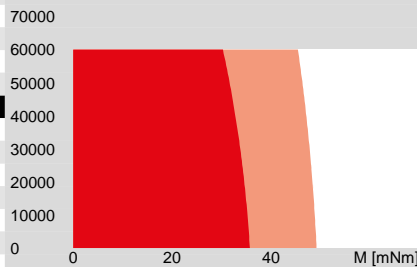

Sensorless: typical 2000 sterilization cycles  
Hall sensors: typical 1000 sterilization cycles  
Sterilization with steam  
Temperature +134°C ±4°C  
Compression pressure up to 2.3 bar  
Rel. humidity 100%  
Cycle length 18 min.

■ Continuous operation  
■ Continuous operation with reduced thermal resistance R<sub>th2</sub> 50%  
□ Short term operation

### Mechanical data ball bearings

23_ Max. speed	rpm	60000
24_ Axial play	mm	0...0.24
Preload	N	4
Direction of force	pull	
25_ Radial play	preloaded	
26_ Max. axial load (dynamic)	N	4
27_ Max. force for press fits (static)	N	110
(static, shaft supported)	N	6000
28_ Max. radial load [mm from flange]	N	16 [5]

### Other specifications

29_ Number of pole pairs		1
30_ Number of phases		3
31_ Weight of motor	g	148
32_ Typical noise level [rpm]	dBA	55 [50 000]

### Connection A and B, motor (Cable AWG 18)

red Motor winding 1  
black Motor winding 2  
white Motor winding 3

### Connection A, sensors (Cable AWG 26)

orange V<sub>Hall</sub> 3...24 VDC  
blue GND  
yellow Hall sensor 1  
brown Hall sensor 2  
grey Hall sensor 3

Wiring diagram for Hall sensors see page 33

### Connection NTC (Cable AWG 26)

purple NTC  
purple NTC  
Resistance 25°C: 10 kOhm ±1%, beta (25–85°C): 3490 K

### maxon Modular System

maxon gear	maxon sensor	maxon motor control
		379_ESCON Module 50/4 EC-S
		379_ESCON Module 50/5
		379_ESCON 50/5
		379_ESCON 70/10
		382_DEC Module 50/5

### Configuration

Flange front: thread in flange/center thread  
Flange back: without/center thread  
Shaft front: length  
Electric connection: cable length/pin connection  
Temperature Sensor: NTC-Thermistor



# ECX SPEED 22 L brushless

## BLDC motor Ø22 mm

Sterilizable, Ceramic Bearings

**NEW**



**120/233 W 33 mNm 85000 rpm**

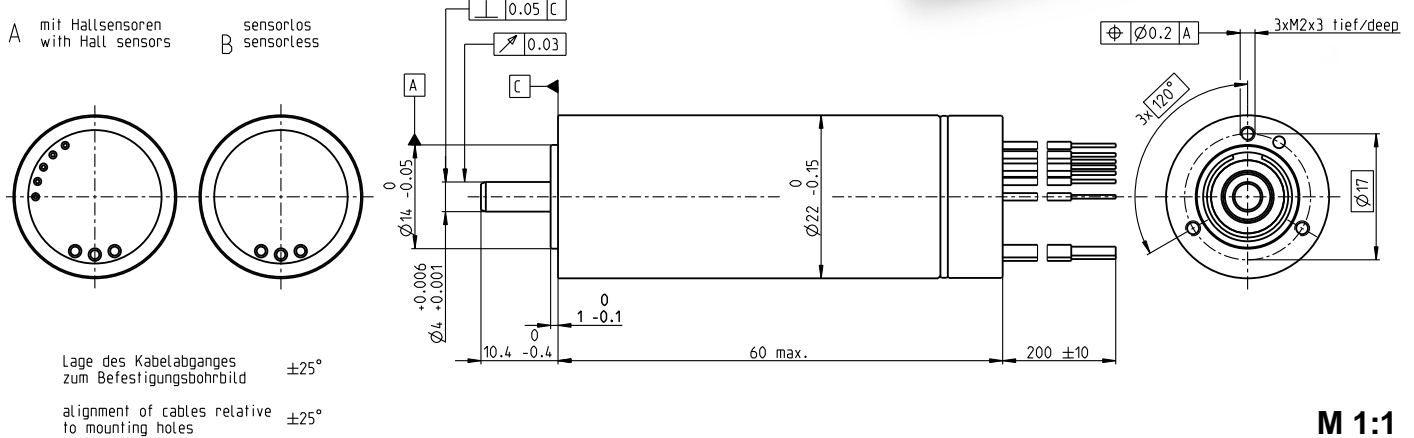

Motor Data					
1_	Nominal voltage	V	24	36	48
2_	No load speed	rpm	54100	56200	57300
3_	No load current	mA	425	303	235
4_	Nominal speed	rpm	51800	54000	55200
5_	Nominal torque (max. continuous torque)	mNm	32.6	33.5	31.6
6_	Nominal current (max. continuous current)	A	8.05	5.32	4.14
7_	Stall torque	mNm	965	1160	1120
8_	Stall current	A	228	190	140
9_	Max. efficiency	%	92	92	92
10_	Terminal resistance	Ω	0.105	0.189	0.343
11_	Terminal inductance	mH	0.0114	0.0237	0.0406
12_	Torque constant	mNm/A	4.23	6.11	7.99
13_	Speed constant	rpm/V	2260	1560	1200
14_	Speed/torque gradient	rpm/mNm	56.1	48.4	51.3
15_	Mechanical time constant	ms	1.39	1.2	1.27
16_	Rotor inertia	gcm <sup>2</sup>	2.36	2.36	2.36

Thermal data		Operating Range	
17_	Thermal resistance housing-ambient	K/W	10
18_	Thermal resistance winding-housing	K/W	0.823
19_	Thermal time constant winding	s	2.9
20_	Thermal time constant motor	s	507
21_	Ambient temperature	°C	-40...+135
22_	Max. winding temperature	°C	155

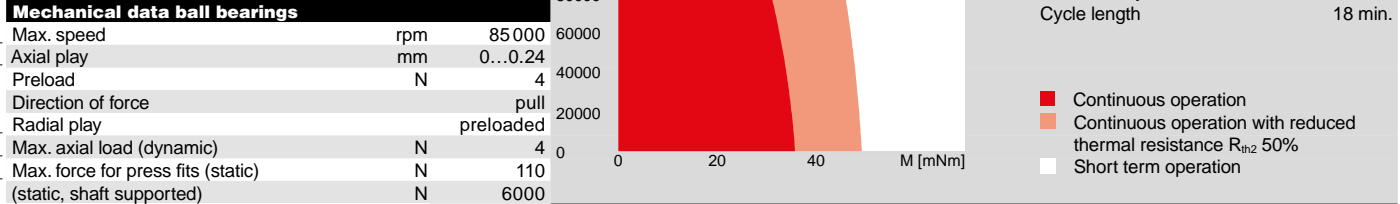

Mechanical data ball bearings		maxon Modular System		
23_	Max. speed	rpm	85000	
24_	Axial play	mm	0...0.24	
	Preload	N	4	
	Direction of force		pull	
25_	Radial play		preloaded	
26_	Max. axial load (dynamic)	N	4	
27_	Max. force for press fits (static) (static, shaft supported)	N	110	
28_	Max. radial load [mm from flange]	N	16 [5]	
29_	Number of pole pairs		1	maxon gear
30_	Number of phases		3	maxon sensor
31_	Weight of motor	g	148	maxon motor control
32_	Typical noise level [rpm]	dBA	55 [50000]	379_ESCON Module 50/4 EC-S 379_ESCON Module 50/5 379_ESCON 50/5 379_ESCON 70/10 382_DEC Module 50/5

**Connection A and B, motor** (Cable AWG 18)  
red Motor winding 1  
black Motor winding 2  
white Motor winding 3

**Connection A, sensors** (Cable AWG 26)  
orange V<sub>Hall</sub> 3...24 VDC  
blue GND  
yellow Hall sensor 1  
brown Hall sensor 2  
grey Hall sensor 3

Wiring diagram for Hall sensors see page 33

**Connection NTC** (Cable AWG 26)  
purple NTC  
purple NTC  
Resistance 25°C: 10 kOhm ±1%, beta (25–85°C): 3490 K

**Configuration**  
Flange front: thread in flange/center thread  
Flange back: without/center thread  
Shaft front: length  
Electric connection: cable length/pin connection  
Temperature Sensor: NTC-Thermistor

# Explanation for Terminology maxon ECX

## Dimensional drawings

Presentation of the views according to the projection method E (ISO).  All dimensions in [mm].

## Motor Data

The values in lines 2–15 are valid when using block commutation.

### 1 Nominal voltage $U_N$ [Volt]

is the applied voltage between two powered phases in block commutation. See page 32 for the timing diagram of the voltage in the three phases. All nominal data (lines 2–9) refer to this voltage. Lower and higher voltages are permissible, provided that limits are not exceeded.

### 2 No load speed $n_0$ [rpm] $\pm 10\%$

is the speed at which the unloaded motor runs with the nominal voltage applied. It is approximately proportional to the applied voltage.

### 3 No load current $I_0$ [mA] $\pm 50\%$

This is the typical current that the unloaded motor draws when operating at nominal voltage. It increases with rising speed owing to bearing friction and iron losses. No load friction depends heavily on temperature. It decreases in extended operation and increases at lower temperatures.

### 4 Nominal speed $n_N$ [rpm]

is the speed set for operation at nominal voltage and nominal torque at a motor temperature of 25°C.

### 5 Nominal torque $M_N$ [mNm]

is the torque generated for operation at nominal voltage and nominal current at a motor temperature of 25°C. It is at the limit of the motor's continuous operation range. Higher torques heat up the winding too much.

### 6 Nominal current $I_N$ [A]

is the current in the active phase in block commutation that generates the nominal torque at the given nominal speed (= max. permissible continuous load current). The maximum winding temperature is reached at 25°C ambient temperature in continuous operation with  $I_N$ .  $I_N$  decreases as speed increases due to additional losses in the lamination. For the EC 10 flat motor the nominal operating point is given varying at half no load speed, as the thermal limit is not reached at nominal voltage.

### 7 Stall torque $M_{Ht}$ [mNm]

is the torque produced by the motor when at standstill. Rising motor temperatures reduce stall torque.

### 8 Stall current $I_A$ [A]

is the quotient from nominal voltage and the motor's terminal resistance. Stall current is equivalent to stall torque. With larger motors,  $I_A$  cannot often be reached due to the amplifier's current limits.

### 9 Max. efficiency $\eta_{max}$ [%]

is the optimal relationship between input and output power at nominal voltage. It also doesn't always denote the optimal operating point.

### 10 Terminal resistance phase to phase $R$ [ $\Omega$ ]

is determined through the resistance at 25°C between two connections.

### 11 Terminal inductance phase to phase $L$ [mH]

is the winding inductance between two connections. It is measured at 1 kHz, sinusoidal.

### 12 Torque constant $k_M$ [mNm/A]

This may also be referred to as «specific torque» and represents the quotient from generated torque and applicable current.

### 13 Speed constant $k_n$ [rpm/V]

indicates the theoretical no load speed per volt of applied voltage, disregarding friction losses.

### 14 Speed/torque gradient $\Delta n/\Delta M$ [rpm/mNm]

The speed/torque gradient is an indicator of the motor's performance. The smaller the value, the more powerful the motor and consequently the less motor speed varies with load variations. It is based on the quotient of ideal no load speed and ideal stall torque (tolerance  $\pm 20\%$ ). With flat motors, the real gradient depends on speed: at higher speeds, it is steeper, but flatter at lower speeds. The real gradient at nominal voltage can be approximated by a straight line between no load speed and the nominal operating point (see page 45).

### 15 Mechanical time constant $\tau_m$ [ms]

is the time required for the rotor to accelerate from standstill to 63% of its no load speed.

### 16 Rotor moment of inertia $J_R$ [gcm<sup>2</sup>]

is the mass moment of inertia of the rotor, based on the axis of rotation.

### 17 Thermal resistance housing-ambient $R_{th2}$ [K/W]

and

### 18 Thermal resistance winding-housing $R_{th1}$ [K/W]

Characteristic values of thermal contact resistance without additional heat sinking. Lines 17 and 18 combined define the maximum heating at a given power loss (load). Thermal resistance  $R_{th2}$  on motors with metal flanges can decrease by up to 80% if the motor is coupled directly to a good heat-conducting (e.g. metallic) mounting rather than a plastic panel.

### 19 Thermal time constant winding $\tau_w$ [s]

and

### 20 Thermal time constant motor $\tau_s$ [s]

These are the typical reaction times for a temperature change of winding and motor. It can be seen that the motor reacts much more sluggishly in thermal terms than the winding. The values are calculated from the product of thermal capacity and given heat resistances.

### 21 Ambient temperature [°C]

Operating temperature range. This derives from the heat reliability of the materials used and viscosity of bearing lubrication.

### 22 Max. winding temperature [°C]

Maximum permissible winding temperature.

### 23 Max. speed $n_{max}$ [rpm]

is the maximum recommended speed based on thermal and mechanical perspectives. A reduced service life can be expected at higher speeds.

### 24 Axial play [mm]

On motors that are not preloaded, these are the tolerance limits for the bearing play. A preload cancels out the axial play up to the specified axial force. When load is applied in the direction of the preload force (away from the flange), the axial play is always zero. The length tolerance of the shaft includes the maximum axial play.

### 25 Radial play [mm]

Radial play is the bearing's radial movement. A spring is utilized to preload the motor's bearings, eliminating radial play up to a given axial load.

### 26/27 Max. axial load [N]

**Dynamically:** axial loading permissible in operation. If different values apply for traction and thrust, the smaller value is given.

**Statically:** maximum axial force applying to the shaft at standstill where no residual damage occurs.

**Shaft supported:** maximum axial force applying to the shaft at standstill if the force is not input at the other shaft end. This is not possible for motors with only one shaft end.

### 28 Max. radial load [N]

The value is given for a typical clearance from the flange; this value falls the greater the clearance.

### 29 Number of pole pairs

Number of north poles of the permanent magnet. The phase streams and commutation signals pass through per revolution  $p$  cycles. Servo-controllers require the correct details of the number of pole pairs.

### 30 Number of phases

All maxon EC motors have three phases.

### 31 Weight of motor [g]

### 32 Typical noise level [dBA]

is that statistical average of the noise level measured according to maxon standard (10 cm distance radially to the drive, no load operation at a speed of 6,000 or 50,000 rpm. The drive lies freely on a plastic foam mat in the noise chamber).

The acoustic noise level depends on a number of factors, such as component tolerances, and it is greatly influenced by the overall system in which the drive is installed. When the drive is installed in an unfavorable constellation, the noise level may be significantly higher than the noise level of the drive alone.

The acoustic noise level is measured and determined during product qualification. In manufacturing, a structure-borne noise test is performed with defined limits. Impermissible deviations can thus be identified.

### 33 Max. torque $M_{max}$ [mNm]

Maximum torque the motor can briefly deliver. It is limited by the overload protection of the electronics.

### 34 Max. current $I_{max}$ [A]

Surge current with which the peak torque is generated at nominal voltage. With an active speed controller, surge current is not proportionate to the torque, but also depends on the supply voltage. As a result, this value only applies at nominal voltage.

### 35 Type of control

«Speed» means that the drive is fitted with an integral speed controller. «Controlled» means that the drive is fitted with true commutation electronics.

### 36 Supply voltage $+V_{CC}$ [V]

Range of supply voltages measured in respect of GND at which the drive functions.

### 37 Speed set value input $U_c$ [V]

Range of analog voltage for set speed value measured in respect of GND. For 2 wire solutions, the supply voltage acts as speed setting at the same time.

### 38 Scaling Set speed value input $k_c$ [rpm/V]

Set speed value  $n_c$  is based on the product  $n_c = k_c \cdot U_c$ .

### 39 Speed range

Achievable speeds in the controlled range.

### 40 Max. acceleration

The set speed value follows a sudden set point change with a ramp. This value indicates the increase in the ramp.

# maxon GPX

## Planetary Gearhead maxon GPX

maxon GPX gearheads make an impression with the highest power transmission in a very short compact design. The modular construction and the scaled stages form the basis for a custom made drive solution. High torque, high speed, low noise, low backlash; maxon GPX gearheads fulfill practically all requirements.

maxon GPX gearheads can be configured online and are ready for delivery within 11 working days.

[gpx.maxonmotor.com](http://gpx.maxonmotor.com)



**maxon motor**

driven by precision

# GPX 8

## Planetary Gearhead Ø8 mm

NEW



Key Data		A Standard Version
Max. transmittable power	W	0.84
Max. continuous torque	Nm	0.1
Max. continuous input speed	rpm	12000
Ambient temperature	°C	-15 ... +80
Bearing at output		Ball bearing

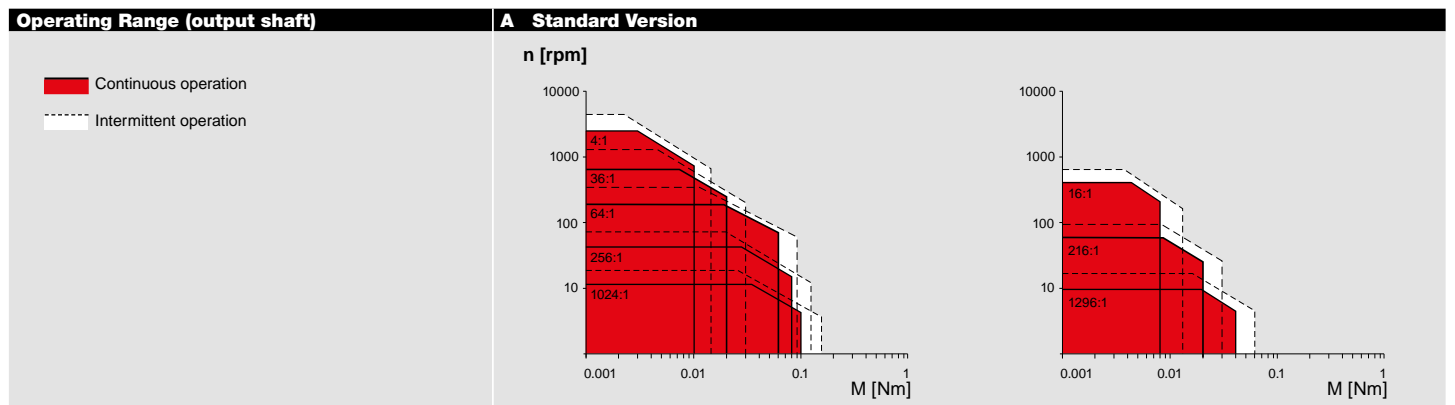

Specifications	A Standard Version	1	2	3	3	4	4	5
Number of stages		1	2	2	3	3	4	5
Max. transmittable power (continuous)	W	0.840	0.520	0.140	0.390	0.060	0.130	0.040
Max. transmittable power (intermittent)	W	1.05	0.650	0.180	0.490	0.080	0.160	0.050
Max. continuous torque	Nm	0.010	0.020	0.008	0.060	0.020	0.080	0.100
Max. intermittent torque	Nm	0.015	0.030	0.012	0.090	0.030	0.120	0.150
Max. continuous input speed	rpm	12000	12000	12000	12000	12000	12000	12000
Max. intermittent input speed	rpm	20000	20000	20000	20000	20000	20000	20000
Max. efficiency	%	90	81	76	73	66	65	59
Average backlash no load	°	1.8	2.0	2.4	2.2	2.6	2.5	2.8
Max. axial load (dynamic)	N	5.0	5.0	5.0	5.0	5.0	5.0	5.0
Max. radial load, 5 mm from flange	N	5	6	6	7	7	8	8
Gearhead length L1	mm	5.5	8.1	8.3	10.7	11.1	13.3	15.9
Weight	g	2.6	3.2	3.2	3.8	3.8	4.4	5.0

Configuration	A Standard Version	1	2	2	3	3	4	4	5
Number of stages		1	2	2	3	3	4	4	5
Reduction	X:1	4	16	36	64	216	256	1296	1024
Version		Standard							
Flange		Standard flange							
Shaft		Length/flat face							

maxon Modular System		Page	Dimensions	M 2:1
maxon EC motor	Number of stages			
ECX 8	1-5	28		

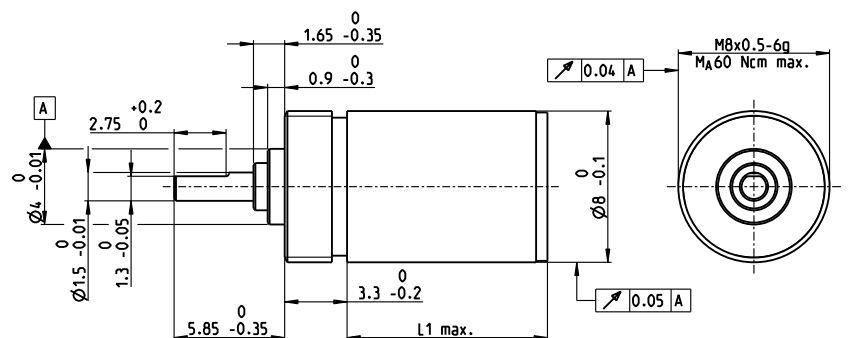

xdrives.maxonmotor.com



# GPX 10

## Planetary Gearhead Ø10 mm



Key Data		A Standard Version	
Max. transmittable power	W	1.6	
Max. continuous torque	Nm	0.15	
Max. continuous input speed	rpm	12000	
Ambient temperature	°C	-15 ... +80	
Bearing at output		Ball bearing	

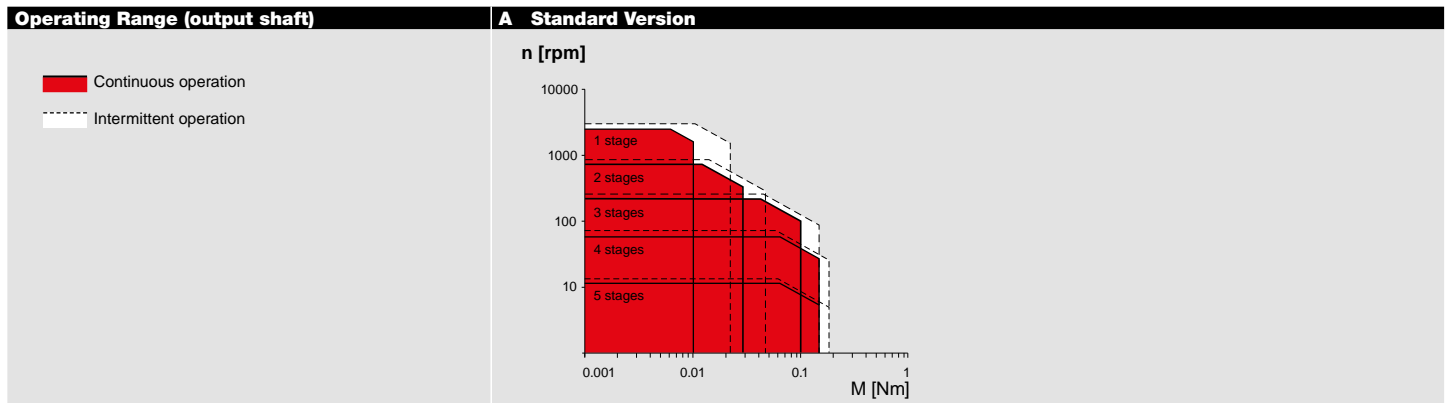

Specifications		A Standard Version				
Number of stages		1	2	3	4	5
Max. transmittable power (continuous)	W	1.6	1.2	1.0	0.40	0.10
Max. transmittable power (intermittent)	W	2.0	1.5	1.3	0.50	0.13
Max. continuous torque	Nm	0.01	0.03	0.10	0.15	0.15
Max. intermittent torque	Nm	0.02	0.05	0.15	0.20	0.20
Max. continuous input speed	rpm	12000	12000	12000	12000	12000
Max. intermittent input speed	rpm	15000	15000	15000	15000	15000
Max. efficiency	%	90	81	73	65	59
Average backlash no load	°	1.5	1.8	2.0	2.2	2.5
Max. axial load (dynamic)	N	5	5	5	5	5
Max. radial load, 5 mm from flange	N	5	10	15	20	25
Gearhead length L1	mm	10.4	14.1	17.2	20.4	23.5
Weight	g	6.7	7.2	7.7	8.2	8.7

Configuration		A Standard Version				
Number of stages		1	2	3	4	5
Reduction	X:1	4	16	64	256	1024
Version		Standard				
Flange		Standard flange				
Shaft		Length/flat face				

maxon Modular System		Page	Dimensions
maxon DC motor	Number of stages		
DCX 10 S	1-5	12	
DCX 10 L	1-5	13	

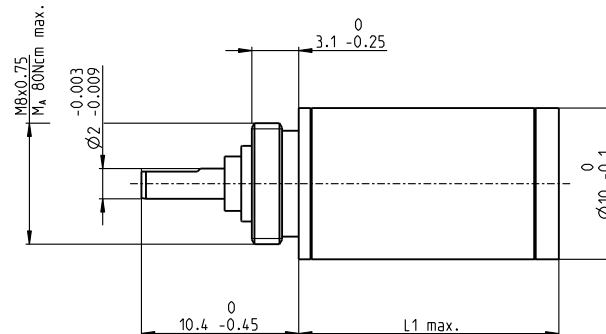

xdrives.maxonmotor.com

# GPX 12

## Planetary Gearhead Ø12 mm

**NEW**



Key Data		A Standard Version	C Ceramic Version
Max. transmittable power	W	2	2
Max. continuous torque	Nm	0.17	0.2
Max. continuous input speed	rpm	16000	16000
Ambient temperature	°C	-40 ... +100	-40 ... +100
Bearing at output		Ball bearing	Ball bearing

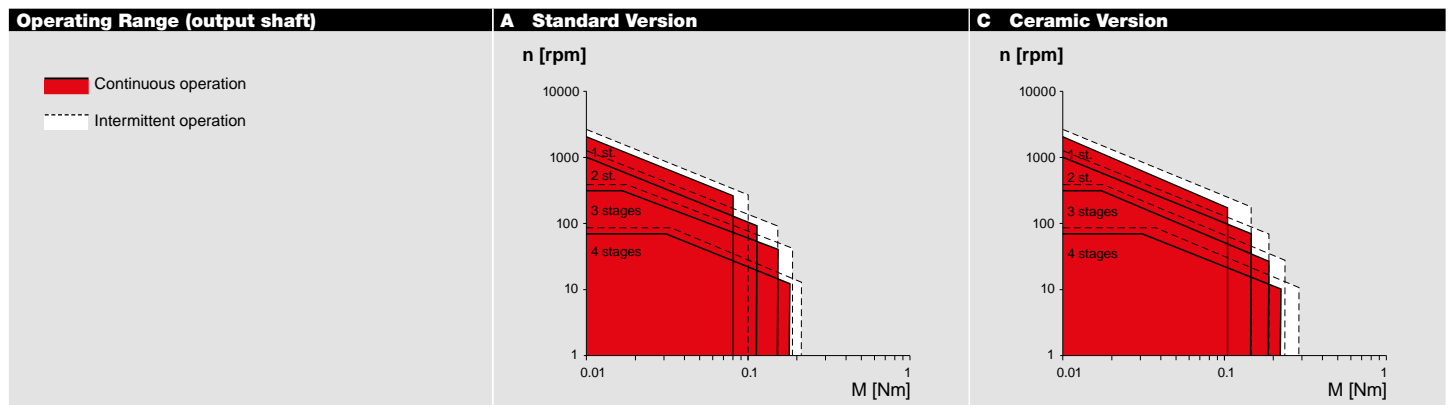

Specifications		A Standard Version				C Ceramic Version			
		1	2	3	4	1	2	3	4
Number of stages		1	2	3	4	1	2	3	4
Max. transmittable continuous power	W	2.0	1.0	0.50	0.25	2.0	1.0	0.50	0.25
Max. transmittable intermittent power	W	2.5	1.25	0.65	0.30	2.5	1.25	0.65	0.30
Max. continuous torque	Nm	0.08	0.11	0.14	0.17	0.08	0.11	0.14	0.17
Max. intermittent torque	Nm	0.10	0.14	0.18	0.21	0.10	0.14	0.18	0.21
Max. continuous input speed	rpm	16000	16000	16000	16000	16000	16000	16000	16000
Max. intermittent input speed	rpm	20000	20000	20000	20000	20000	20000	20000	20000
Max. efficiency	%	90	80	75	65	90	80	75	65
Average backlash no load	°	1.4	1.6	2.0	2.4	1.4	1.6	2.0	2.4
Max. axial load (dynamic)	N	20	20	20	20	20	20	20	20
Max. radial load, 5 mm from flange	N	30	35	50	50	30	35	50	50
Gearhead length L1	mm	15.5	20.4	25.2	30.1	15.5	20.4	25.2	30.1
Weight	g	11	14	17	19	11	14	17	19

Configuration		A Standard Version				C Ceramic Version			
		1	2	3	4	1	2	3	4
Number of stages		1	2	3	4	1	2	3	4
Reduction	X:1	3.9, 5.3	16, 21, 26, 28, 35	62, 83, 103, 111, 138, 150, 172, 186, 231	243, 326, 406, 439, 546, 590, 679, 734, 794, 913, 987, 1135, 1227, 1526	3.9, 5.3	16, 21, 26, 28, 35	62, 83, 103, 111, 138, 150, 172, 186, 231	243, 326, 406, 439, 546, 590, 679, 734, 794, 913, 987, 1135, 1227, 1526
Version		Standard/ceramic version/noise reduced/reduced backlash							
Flange		Standard flange/configurable flange							
Shaft		Length/flat face							

maxon Modular System	Page	Dimensions
maxon DC motor	Number of stages	
DCX 12 S	1-4	14
DCX 12 L	1-4	15

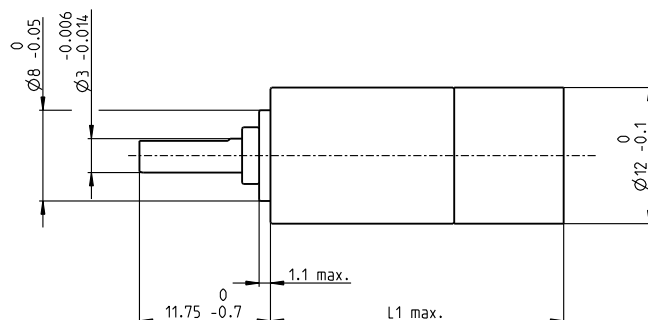

[xdrives.maxonmotor.com](http://xdrives.maxonmotor.com)

# GPX 12

## Planetary Gearhead Ø12 mm

**NEW**



Key Data	LN Noise Reduced	LZ Backlash Reduced
Max. transmittable power	W 1.6	1
Max. continuous torque	Nm 0.14	0.2
Max. continuous input speed	rpm 16000	16000
Ambient temperature	°C -40 ... +85	-40 ... +100
Bearing at output	Ball bearing	Ball bearing
Typical noise level	dBA -5 dBA compared to standard configuration	

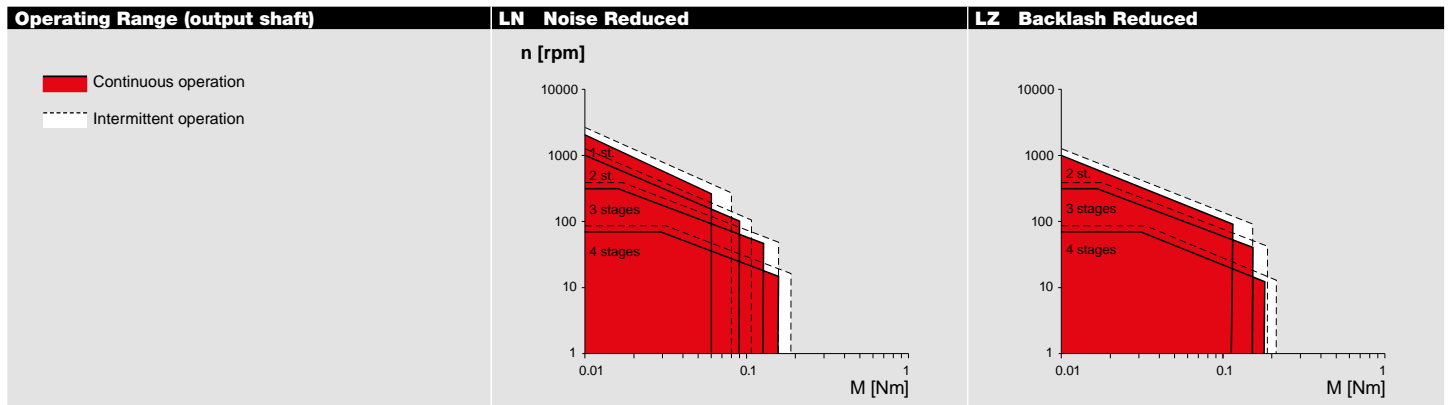

Specifications	LN Noise Reduced				LZ Backlash Reduced			
	1	2	3	4	2	3	4	
Number of stages								
Max. transmittable continuous power	W 1.6	0.8	0.40	0.20	1.0	0.50	0.25	
Max. transmittable intermittent power	W 2.0	1.00	0.50	0.25	1.25	0.65	0.30	
Max. continuous torque	Nm 0.06	0.09	0.11	0.14	0.11	0.14	0.17	
Max. intermittent torque	Nm 0.08	0.11	0.14	0.18	0.14	0.18	0.21	
Max. continuous input speed	rpm 16000	16000	16000	16000	16000	16000	16000	
Max. intermittent input speed	rpm 20000	20000	20000	20000	20000	20000	20000	
Max. efficiency	% 90	80	75	65	80	75	65	
Average backlash no load	° 1.4	1.6	2.0	2.4	1.2	1.4	1.6	
Max. axial load (dynamic)	N 20	20	20	20	20	20	20	
Max. radial load, 5 mm from flange	N 30	35	50	50	35	50	50	
Gearhead length L1	mm 15.5	20.4	25.2	30.1	20.4	25.2	30.1	
Weight	g 11	14	17	19	14	17	19	

Configuration	LN Noise Reduced				LZ Backlash Reduced			
	1	2	3	4	2	3	4	
Number of stages								
Reduction	X:1 3.9, 5.3	16, 21, 26, 28, 35	62, 83, 103, 111, 138, 150, 172, 186, 231	243, 326, 406, 439, 546, 590, 679, 734, 794, 913, 987, 1135, 1227, 1526	16, 21, 26, 28, 35	62, 83, 103, 111, 138, 150, 172, 186, 231	243, 326, 406, 439, 546, 590, 679, 734, 794, 913, 987, 1135, 1227, 1526	
Version	Standard/ceramic version/noise reduced/backlash reduced							
Flange	Standard flange/configurable flange							
Shaft	Length/flat face							

maxon Modular System		Page	Dimensions
maxon DC motor	Number of stages		
DCX 12 S	1-4	14	
DCX 12 L	1-4	15	

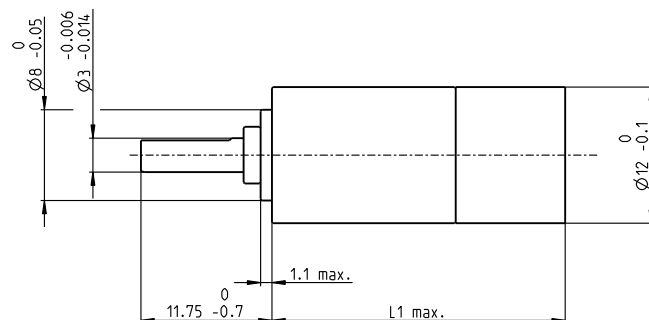

[xdrives.maxonmotor.com](http://xdrives.maxonmotor.com)

# GPX 14

## Planetary Gearhead Ø14 mm



Key Data		A Standard Version	C Ceramic Version
Max. transmittable power	W	4	4.8
Max. continuous torque	Nm	0.3	0.4
Max. continuous input speed	rpm	16000	16000
Ambient temperature	°C	-40 ... +100	-40 ... +100
Bearing at output		Ball bearing	Ball bearing

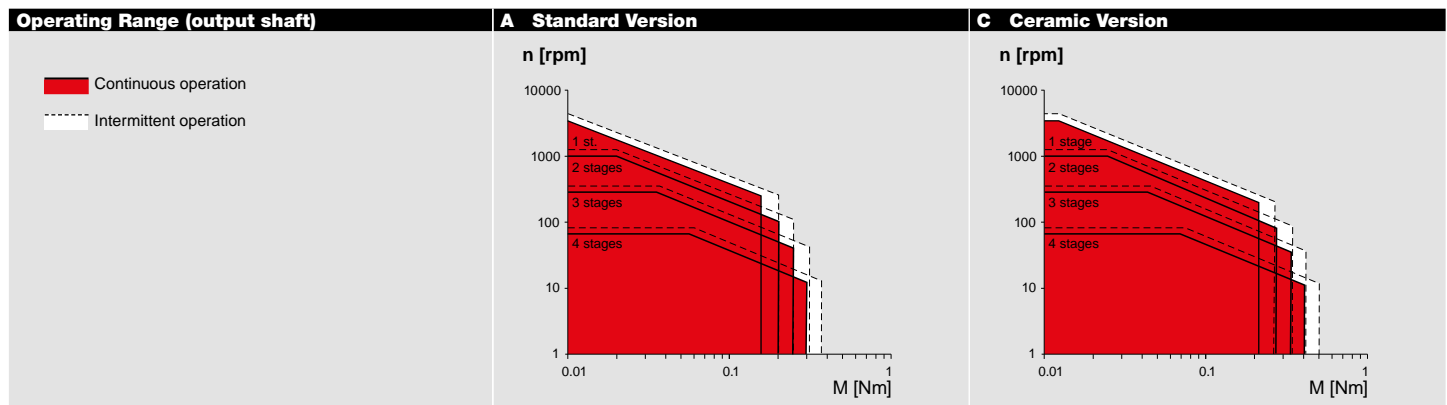

Specifications		A Standard Version				C Ceramic Version			
		1	2	3	4	1	2	3	4
Number of stages		1	2	3	4	1	2	3	4
Max. transmittable continuous power	W	4.0	2.0	1.0	0.4	4.8	2.4	1.2	0.5
Max. transmittable intermittent power	W	5.0	2.5	1.25	0.5	6.0	3.0	1.50	0.6
Max. continuous torque	Nm	0.16	0.20	0.25	0.30	0.21	0.27	0.33	0.40
Max. intermittent torque	Nm	0.20	0.25	0.31	0.38	0.26	0.34	0.41	0.50
Max. continuous input speed	rpm	14000	16000	16000	16000	14000	16000	16000	16000
Max. intermittent input speed	rpm	17500	20000	20000	20000	17500	20000	20000	20000
Max. efficiency	%	90	80	75	65	90	80	75	65
Average backlash no load	°	1.4	1.6	2	2.4	1.4	1.6	2	2.4
Max. axial load (dynamic)	N	20	20	20	20	20	20	20	20
Max. radial load, 5 mm from flange	N	30	45	60	60	30	45	60	60
Gearhead length L1	mm	15.7	20.8	25.5	30.3	15.7	20.8	25.5	30.3
Weight	g	14	19	21	23	14	19	21	23

Configuration		A Standard Version				C Ceramic Version			
		1	2	3	4	1	2	3	4
Number of stages		1	2	3	4	1	2	3	4
Reduction	X:1	3.9, 5.3, 6.6	16, 21, 26, 28, 35	62, 83, 103, 111, 138, 150, 172, 186, 231	243, 326, 406, 439, 546, 590, 679, 734, 794, 913, 987, 1135, 1227, 1526	3.9, 5.3, 6.6	16, 21, 26, 28, 35	62, 83, 103, 111, 138, 150, 172, 186, 231	243, 326, 406, 439, 546, 590, 679, 734, 794, 913, 987, 1135, 1227, 1526
Version		Standard/ceramic version/noise reduced/reduced backlash							
Flange		Standard flange/configurable flange							
Shaft		Length/flat face							

maxon Modular System	Page	Dimensions	M 1:1
maxon DC motor	Number of stages		
DCX 12 S	3-4	14	
DCX 12 L	3-4	15	
DCX 14 L	1-2	16-17	

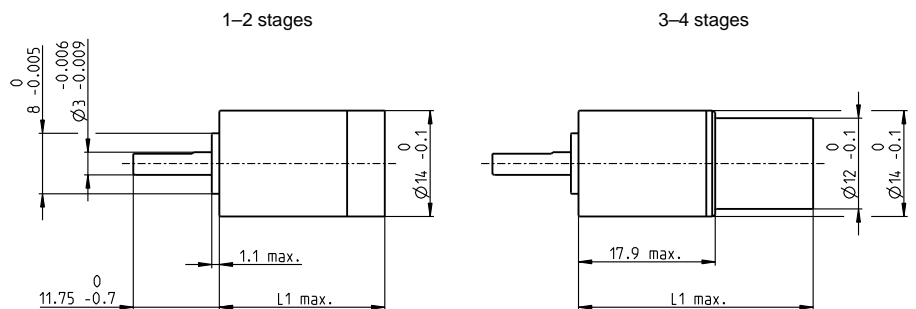

[xdrives.maxonmotor.com](http://xdrives.maxonmotor.com)



# GPX 14

## Planetary Gearhead Ø14 mm



Key Data	LN Noise Reduced	LZ Backlash Reduced
Max. transmittable power	W 3.2	3
Max. continuous torque	Nm 0.24	0.3
Max. continuous input speed	rpm 16000	16000
Ambient temperature	°C -40 ... +85	-40 ... +100
Bearing at output	Ball bearing	Ball bearing
Typical noise level	dBA -5 dBA compared to standard configuration	

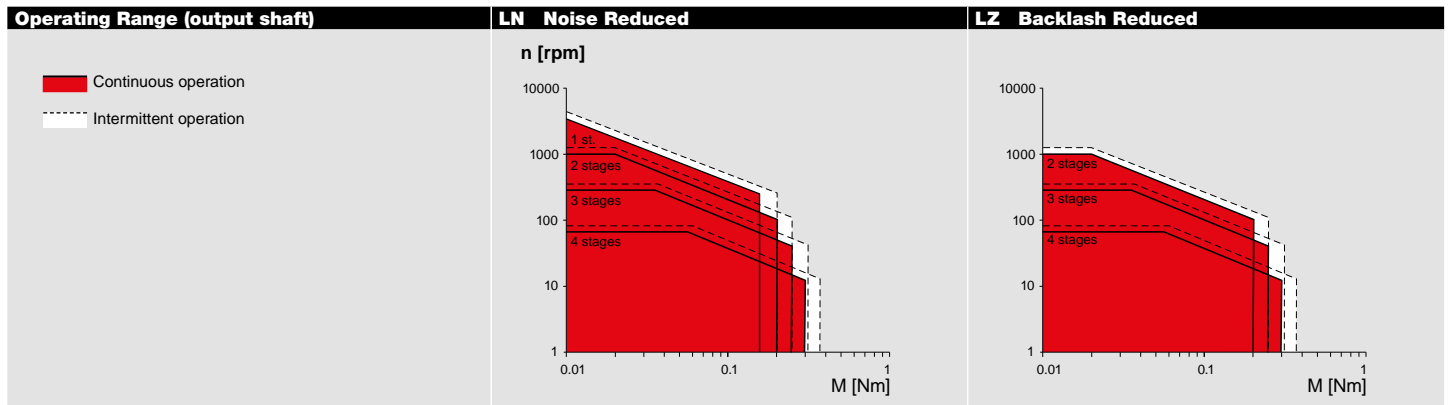

Specifications	LN Noise Reduced	LZ Backlash Reduced
Number of stages	1      2      3      4	2      3      4
Max. transmittable continuous power	W 3.2    1.6    0.8    0.3	2.0    1.0    0.4
Max. transmittable intermittent power	W 4.0    2.0    1.0    0.4	2.5    1.25   0.5
Max. continuous torque	Nm 0.13   0.16   0.20   0.24	0.20   0.25   0.30
Max. intermittent torque	Nm 0.16   0.20   0.25   0.30	0.25   0.31   0.38
Max. continuous input speed	rpm 14000   16000   16000   16000	16000   16000   16000
Max. intermittent input speed	rpm 17500   20000   20000   20000	20000   20000   20000
Max. efficiency	% 90    80    75    65	80    75    65
Average backlash no load	° 1.4    1.6    2.0    2.4	1.2    1.4    1.6
Max. axial load (dynamic)	N 20    20    20    20	20    20    20
Max. radial load, 5 mm from flange	N 30    45    60    60	45    60    60
Gearhead length L1	mm 15.7   20.8   25.5   30.3	20.8   25.5   30.3
Weight	g 14    19    21    23	19    21    23

Configuration	LN Noise Reduced	LZ Backlash Reduced	
Number of stages	1      2      3      4	2      3      4	
Reduction	X:1 3.9, 5.3, 6.6    16, 21, 26, 28, 35    62, 83, 103, 111, 138, 150, 172, 186, 231    243, 326, 406, 439, 546, 590, 679, 734, 794, 913, 987, 1135, 1227, 1526	16, 21, 26, 28, 35    62, 83, 103, 111, 138, 150, 172, 186, 231    243, 326, 406, 439, 546, 590, 679, 734, 794, 913, 987, 1135, 1227, 1526	
Version	Standard/ceramic version/noise reduced/backlash reduced		
Flange	Standard flange/configurable flange		
Shaft	Length/flat face		

maxon Modular System	Page	Dimensions
maxon DC motor	Number of stages	
DCX 12 S	3-4	14
DCX 12 L	3-4	15
DCX 14 L	1-2	16-17

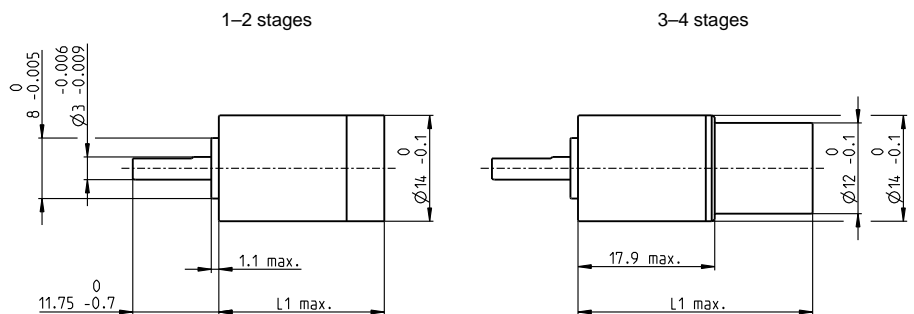

xdrives.maxonmotor.com

# GPX 16

## Planetary Gearhead Ø16 mm



Key Data		A Standard Version	C Ceramic Version
Max. transmittable power	W	6.5	7.8
Max. continuous torque	Nm	0.45	0.6
Max. continuous input speed	rpm	16000	16000
Ambient temperature	°C	-40 ... +100	-40 ... +100
Bearing at output		Ball bearing	Ball bearing

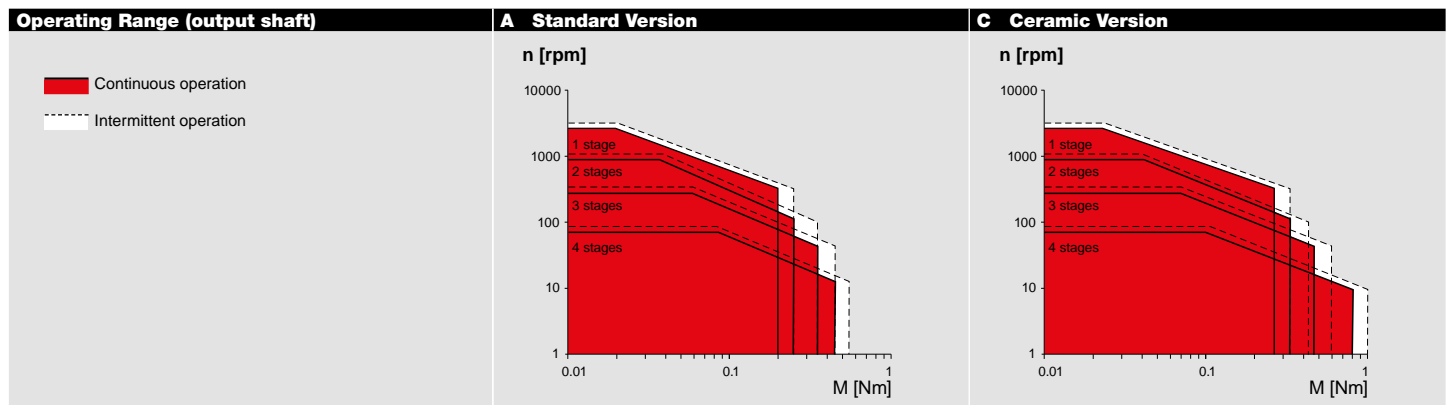

Specifications		A Standard Version				C Ceramic Version			
		1	2	3	4	1	2	3	4
Number of stages		1	2	3	4	1	2	3	4
Max. transmittable continuous power	W	6.5	3.2	1.6	0.60	7.8	3.8	1.9	0.7
Max. transmittable intermittent power	W	8.0	4.0	2.0	0.75	10.0	5.0	2.5	1.0
Max. continuous torque	Nm	0.20	0.25	0.35	0.45	0.27	0.33	0.47	0.60
Max. intermittent torque	Nm	0.25	0.35	0.45	0.55	0.33	0.42	0.58	0.75
Max. continuous input speed	rpm	12000	14000	16000	16000	12000	14000	16000	16000
Max. intermittent input speed	rpm	15000	17500	20000	20000	15000	17500	20000	20000
Max. efficiency	%	90	80	75	65	90	80	75	65
Average backlash no load	°	1.4	1.6	2.0	2.4	1.4	1.6	2.0	2.4
Max. axial load (dynamic)	N	20	20	20	20	20	20	20	20
Max. radial load, 5 mm from flange	N	30	45	70	70	30	45	70	70
Gearhead length L1	mm	15.8	20.7	25.7	30.6	15.8	20.7	25.7	30.6
Weight	g	20	25	27	31	20	25	27	31

Configuration		A Standard Version				C Ceramic Version			
		1	2	3	4	1	2	3	4
Number of stages		1	2	3	4	1	2	3	4
Reduction	X:1	3.9, 5.3, 6.6	16, 21, 26, 28, 35, 44	62, 83, 103, 111, 138, 150, 172, 186, 231	243, 326, 406, 439, 546, 590, 679, 734, 794, 913, 987, 1135, 1227, 1526	3.9, 5.3, 6.6	16, 21, 26, 28, 35, 44	62, 83, 103, 111, 138, 150, 172, 186, 231	243, 326, 406, 439, 546, 590, 679, 734, 794, 913, 987, 1135, 1227, 1526
Version		Standard/ceramic version/noise reduced/reduced backlash/high power							
Flange		Standard flange/configurable flange							
Shaft		Length/flat face							

maxon Modular System	Page
maxon DC motor	Number of stages
DCX 14 L	3-4 16-17
DCX 16 S	1-2 18-19
DCX 16 L	1-2 20-21
DC-max 16 S	1-2 34-35

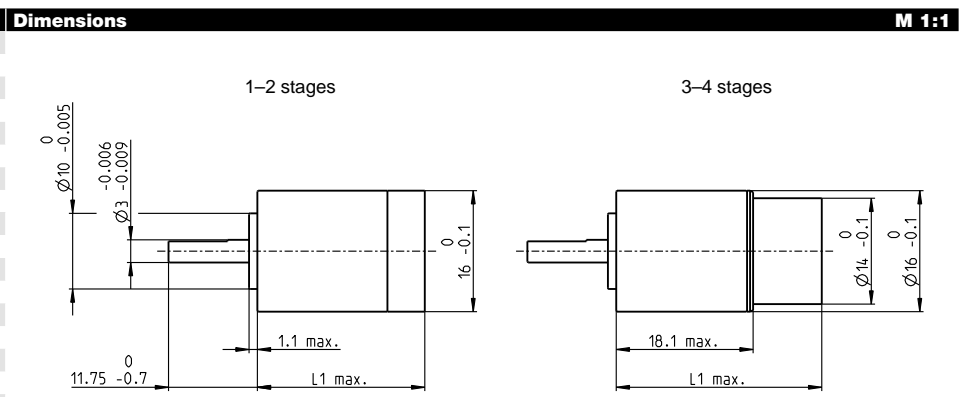

xdrives.maxonmotor.com

# GPX 16

## Planetary Gearhead Ø16 mm



Key Data		LN Noise Reduced	LZ Backlash Reduced
Max. transmittable power	W	5.2	3.2
Max. continuous torque	Nm	0.36	0.5
Max. continuous input speed	rpm	16000	16000
Ambient temperature	°C	-40 ... +85	-40 ... +100
Bearing at output		Ball bearing	Ball bearing
Typical noise level	dBA	-5 dBA compared to standard configuration	

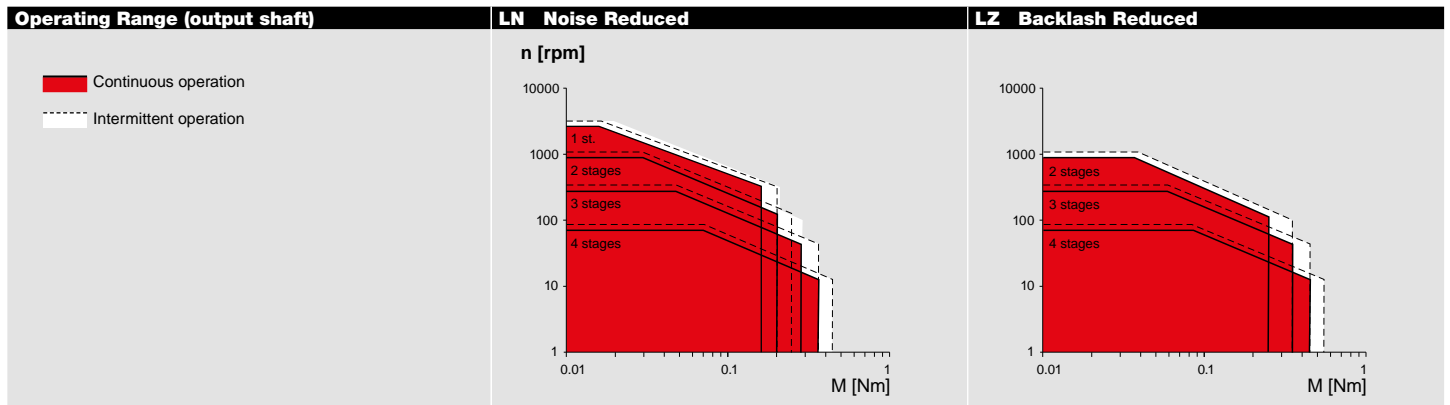

Specifications		LN Noise Reduced				LZ Backlash Reduced			
		1	2	3	4	2	3	4	
Number of stages		1	2	3	4	2	3	4	
Max. transmittable continuous power	W	5.2	2.6	1.3	0.5	3.2	1.6	0.6	
Max. transmittable intermittent power	W	6.5	3.3	1.6	0.6	4.0	2.0	0.8	
Max. continuous torque	Nm	0.16	0.20	0.28	0.36	0.25	0.35	0.45	
Max. intermittent torque	Nm	0.20	0.25	0.35	0.45	0.35	0.45	0.55	
Max. continuous input speed	rpm	12000	14000	16000	16000	14000	16000	16000	
Max. intermittent input speed	rpm	15000	17500	20000	20000	17500	20000	20000	
Max. efficiency	%	90	80	75	65	80	75	65	
Average backlash no load	°	1.4	1.6	2.0	2.4	1.3	1.6	1.9	
Max. axial load (dynamic)	N	20	20	20	20	20	20	20	
Max. radial load, 5 mm from flange	N	30	45	70	70	45	70	70	
Gearhead length L1	mm	15.8	20.7	25.7	30.6	20.7	25.7	30.6	
Weight	g	20	25	27	30.6	25	27	30.6	

Configuration		LN Noise Reduced				LZ Backlash Reduced			
		1	2	3	4	2	3	4	
Number of stages		1	2	3	4	2	3	4	
Reduction	X:1	3.9, 5.3, 6.6	16, 21, 26, 28, 35, 44	62, 83, 103, 111, 138, 150, 172, 186, 231	243, 326, 406, 439, 546, 590, 679, 734, 794, 913, 987, 1135, 1227, 1526	16, 21, 26, 28, 35, 44	62, 83, 103, 111, 138, 150, 172, 186, 231	243, 326, 406, 439, 546, 590, 679, 734, 794, 913, 987, 1135, 1227, 1526	
Version		Standard/ceramic version/noise reduced/backlash reduced/high power							
Flange		Standard flange/configurable flange							
Shaft		Length/flat face							

maxon Modular System		Page	Dimensions
maxon DC motor	Number of stages		
DCX 14 L	3-4	16-17	
DCX 16 S	1-2	18-19	
DCX 16 L	1-2	20-21	
DC-max 16 S	1-2	34-35	

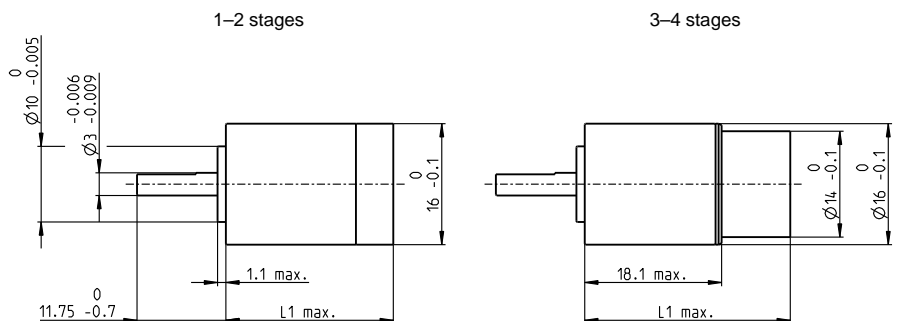

xdrives.maxonmotor.com

# GPX 16

## Planetary Gearhead Ø16 mm

**NEW**



Key Data		HP High Power
Max. transmittable power	W	8
Max. continuous torque	Nm	0.9
Max. continuous input speed	rpm	16000
Ambient temperature	°C	-40 ... +100
Bearing at output		Ball bearing

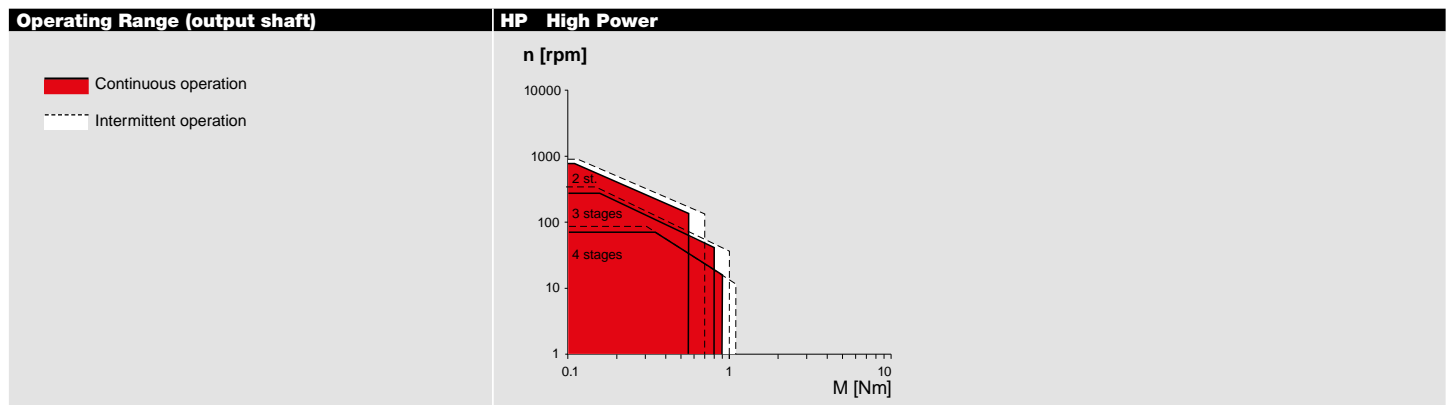

Specifications		HP High Power		
		2	3	4
Number of stages		2	3	4
Max. transmittable power (continuous)	W	8.0	4.0	1.5
Max. transmittable power (intermittent)	W	10.0	4.4	1.5
Max. continuous torque	Nm	0.55	0.80	0.90
Max. intermittent torque	Nm	0.70	1.00	1.10
Max. continuous input speed	rpm	12000	14000	16000
Max. intermittent input speed	rpm	15000	17500	20000
Max. efficiency	%	75	65	55
Average backlash no load	°	1.6	2.0	2.4
Max. axial load (dynamic)	N	30	30	30
Max. radial load, 5 mm from flange	N	80	90	90
Gearhead length L1	mm	26.1	30.8	35.6
Weight	g	31	35	39

Configuration		HP High Power		
		2	3	4
Number of stages		2	3	4
Reduction	X:1	16, 21, 26, 28, 35, 44	62, 83, 103, 111, 138, 150, 172, 186, 231	243, 326, 406, 439, 546, 590, 679, 734, 794, 913, 987, 1135, 1227, 1526
Version		Standard/ceramic version/noise reduced/backlash reduced/high power		
Flange		Standard flange/configurable flange		
Shaft		Length/flat face/cross hole		

maxon Modular System		Page
maxon DC motor	Number of stages	
DCX 14 L	4	16–17
DCX 16 S	2–3	18–19
DCX 16 L	2–3	20–21

### Dimensions M 1:1

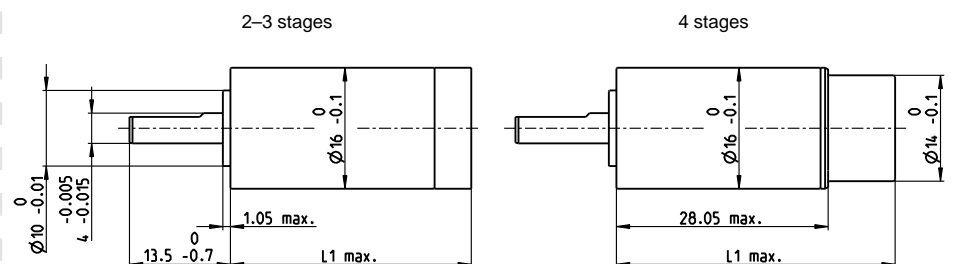

[xdrives.maxonmotor.com](http://xdrives.maxonmotor.com)



# GPX 16 SPEED

## Planetary Gearhead Ø16 mm

Sterilizable

NEW



Key Data	Without shaft seal	With shaft seal
Max. transmittable power	W 42	42
Max. continuous torque	Nm 0.2	0.2
Max. continuous input speed	rpm 50000	50000
Ambient temperature	°C -10 ... +100	-10 ... +100
Bearing at output	Ball bearing	Ball bearing

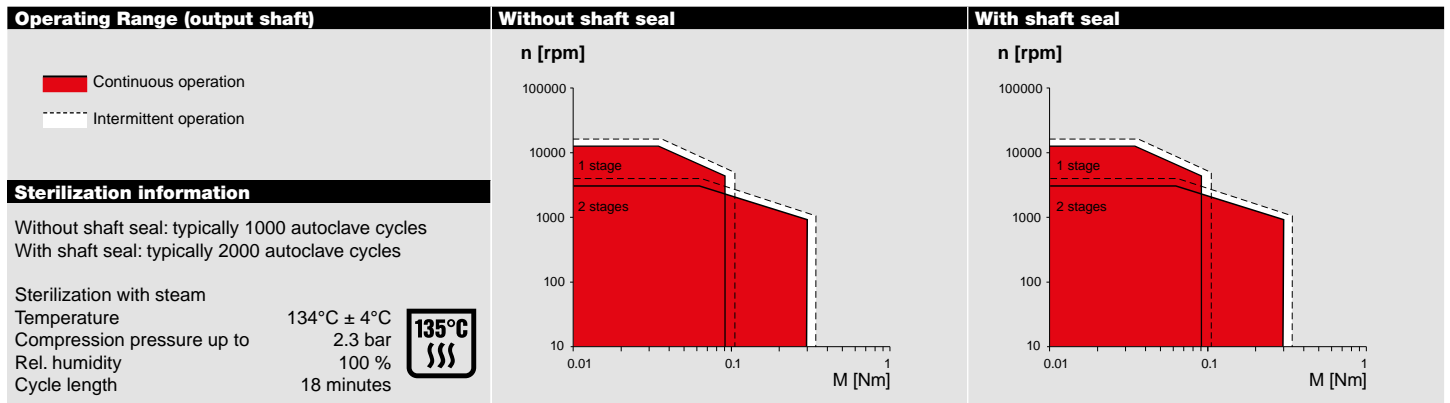

Specifications	Without shaft seal	With shaft seal
Number of stages	1 2	1 2
Max. transmittable continuous power	W 42 20	42 20
Max. transmittable intermittent power	W 50 24	50 24
Max. continuous torque	Nm 0.09 0.2	0.09 0.2
Max. intermittent torque	Nm 0.11 0.24	0.11 0.24
Max. continuous input speed	rpm 50000 50000	50000 50000
Max. intermittent input speed	rpm 60000 60000	60000 60000
Max. efficiency	% 85 80	85 80
Average backlash no load	° 1.4 1.6	1.4 1.6
Max. axial load (dynamic)	N 30 30	30 30
Max. radial load, 5 mm from flange	N 25 35	15 20
Gearhead length L1	mm 27.7 35.1	35.5 42.7
Weight	g 27 35	37.2 45

Configuration	Without shaft seal	With shaft seal
Number of stages	1 2	1 2
Reduction	X:1 3.9, 5.3, 6.6 16, 21, 26, 28, 35, 44	3.9, 5.3, 6.6 16, 21, 26, 28, 35, 44
Version	Without shaft seal/With shaft seal	
Flange	Standard flange/configurable flange	
Shaft	Length/flat face/cross hole	

maxon Modular System	Page	Dimensions	M 1:1
maxon EC motor	Number of stages		
ECX SPEED 16 M	1-2	42-43	
ECX SPEED 16 L	1-2	44-45	

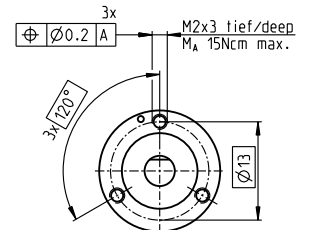
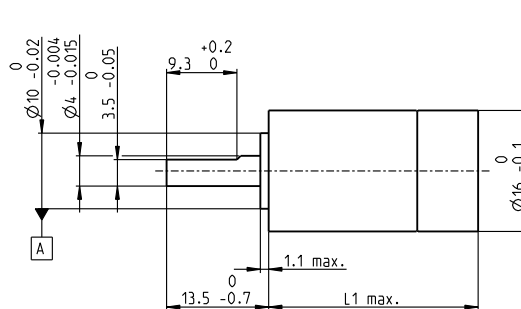

xdrives.maxonmotor.com

# GPX 19

## Planetary Gearhead Ø19 mm

**NEW**



Key Data		A Standard Version	C Ceramic Version
Max. transmittable power	W	13	16
Max. continuous torque	Nm	0.8	1.1
Max. continuous input speed	rpm	14000	14000
Ambient temperature	°C	-40 ... +100	-40 ... +100
Bearing at output		Ball bearing	Ball bearing

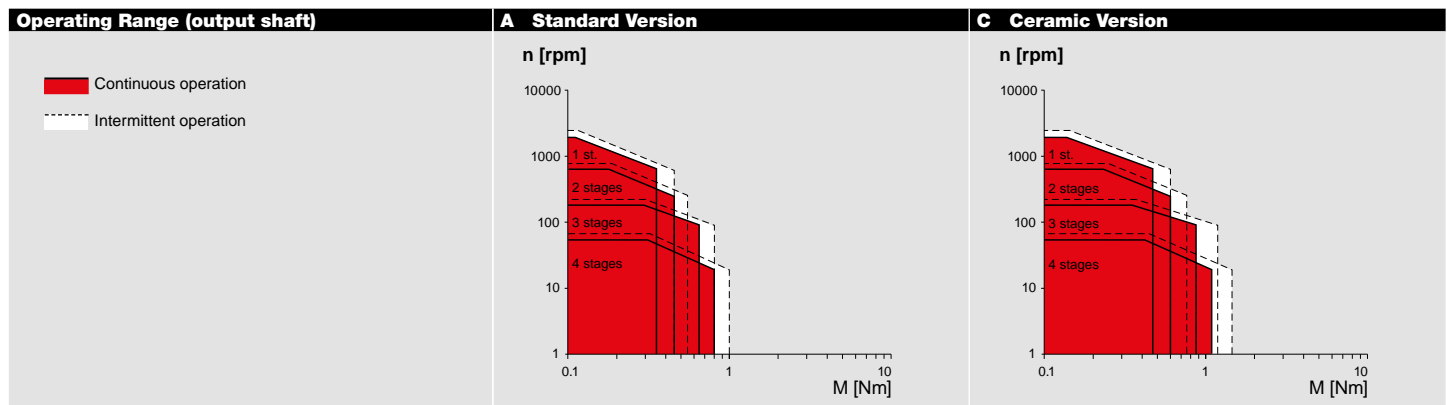

Specifications		A Standard Version				C Ceramic Version			
		1	2	3	4	1	2	3	4
Number of stages		1	2	3	4	1	2	3	4
Max. transmittable continuous power	W	13.0	6.5	3.2	0.9	15.5	7.8	3.9	1.0
Max. transmittable intermittent power	W	16.2	8.1	4.1	1.1	19.4	9.7	4.9	1.3
Max. continuous torque	Nm	0.35	0.45	0.65	0.80	0.47	0.60	0.86	1.05
Max. intermittent torque	Nm	0.45	0.55	0.80	1.00	0.60	0.75	1.10	1.30
Max. continuous input speed	rpm	10000	12000	14000	14000	10000	12000	14000	14000
Max. intermittent input speed	rpm	12500	15000	17500	17500	12500	15000	17500	17500
Max. efficiency	%	90	80	75	65	90	80	75	65
Average backlash no load	°	1.0	1.2	1.4	1.6	1.0	1.2	1.4	1.6
Max. axial load (dynamic)	N	40	40	40	40	40	40	40	40
Max. radial load, 5 mm from flange	N	50	80	90	90	50	80	90	90
Gearhead length L1	mm	16.7	22.9	27.0	36.2	16.7	22.9	27.0	36.2
Weight	g	30	40	43	55	30	40	43	55

Configuration		A Standard Version				C Ceramic Version			
		1	2	3	4	1	2	3	4
Number of stages		1	2	3	4	1	2	3	4
Reduction	X:1	3.9, 5.3, 6.6	16, 21, 26, 28, 35	62, 83, 103, 111, 138, 150, 172, 186, 231	243, 326, 406, 439, 546, 590, 679, 734, 794, 913, 987, 1135, 1227, 1526	3.9, 5.3, 6.6	16, 21, 26, 28, 35	62, 83, 103, 111, 138, 150, 172, 186, 231	243, 326, 406, 439, 546, 590, 679, 734, 794, 913, 987, 1135, 1227, 1526
Version		Standard/ceramic version/noise reduced/reduced backlash							
Flange		Standard flange/configurable flange							
Shaft		Length/flat face/cross hole							

maxon Modular System	Page	Dimensions	M 1:1
maxon DC motor	Number of stages		
DCX 16 S	3-4	18-19	
DCX 16 L	3-4	20-21	
DCX 19 S	1-2	22-23	
DC-max 16 S	3-4	34-35	

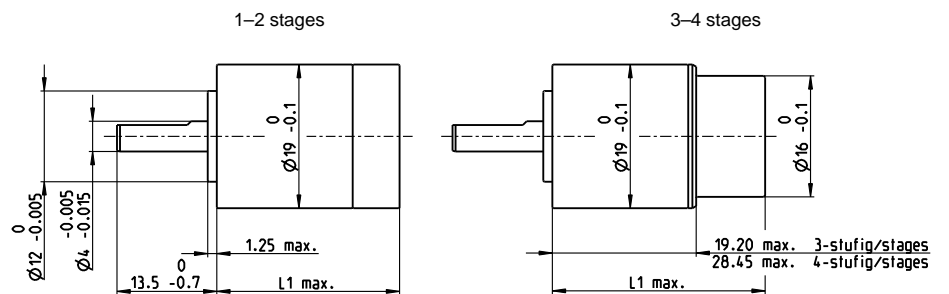

[xdrives.maxonmotor.com](http://xdrives.maxonmotor.com)

# GPX 19

## Planetary Gearhead Ø19 mm

**NEW**



Key Data		LN Noise Reduced	LZ Backlash Reduced
Max. transmittable power	W	10.4	7
Max. continuous torque	Nm	0.64	0.8
Max. continuous input speed	rpm	14000	14000
Ambient temperature	°C	-40 ... +85	-40 ... +100
Bearing at output		Ball bearing	Ball bearing
Typical noise level	dBA	-5 dBA compared to standard configuration	

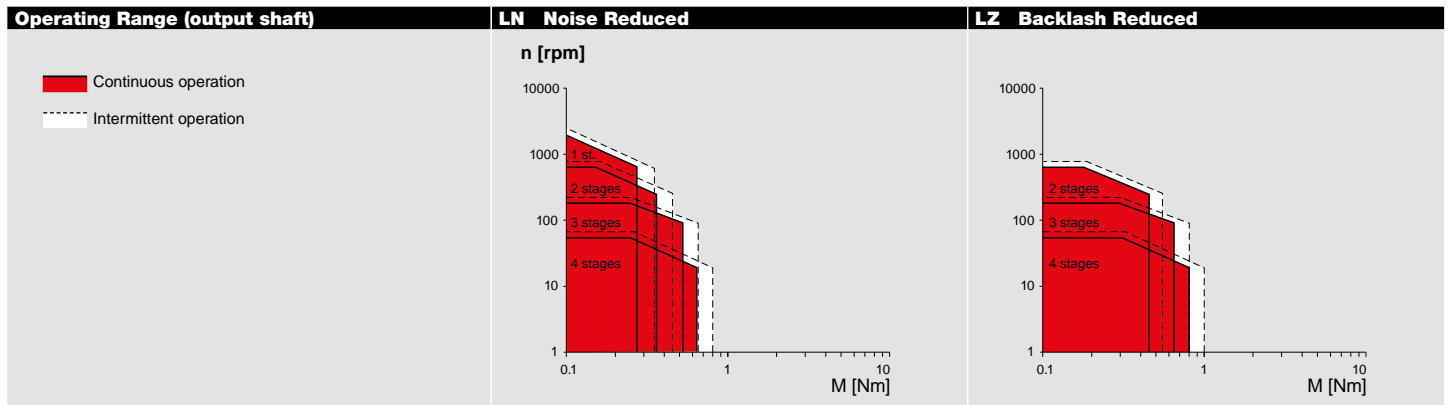

Specifications	LN Noise Reduced				LZ Backlash Reduced			
	1	2	3	4	2	3	4	
Number of stages	1	2	3	4	2	3	4	
Max. transmittable continuous power	W	10.4	5.2	2.6	0.7	6.5	3.2	0.9
Max. transmittable intermittent power	W	13.0	6.5	3.2	0.9	8.1	4.1	1.1
Max. continuous torque	Nm	0.28	0.36	0.52	0.64	0.45	0.65	0.80
Max. intermittent torque	Nm	0.35	0.45	0.65	0.80	0.55	0.80	1.00
Max. continuous input speed	rpm	10000	12000	14000	14000	12000	14000	14000
Max. intermittent input speed	rpm	12500	15000	17500	17500	15000	17500	17500
Max. efficiency	%	90	80	75	65	80	75	65
Average backlash no load	°	1.0	1.2	1.4	1.6	1.0	1.1	1.3
Max. axial load (dynamic)	N	40	40	40	40	40	40	40
Max. radial load, 5 mm from flange	N	50	80	90	90	80	90	90
Gearhead length L1	mm	16.7	22.9	27.0	36.2	22.9	27.0	36.2
Weight	g	30	40	43	55	40	43	55

Configuration	LN Noise Reduced				LZ Backlash Reduced			
	1	2	3	4	2	3	4	
Number of stages	1	2	3	4	2	3	4	
Reduction	X:1	3.9, 5.3, 6.6	16, 21, 26, 28, 35	62, 83, 103, 111, 138, 150, 172, 186, 231	243, 326, 406, 439, 546, 590, 679, 734, 794, 913, 987, 1135, 1227, 1526	16, 21, 26, 28, 35	62, 83, 103, 111, 138, 150, 172, 186, 231	243, 326, 406, 439, 546, 590, 679, 734, 794, 913, 987, 1135, 1227, 1526
Version	Standard/ceramic version/noise reduced/backlash reduced							
Flange	Standard flange/configurable flange							
Shaft	Length/flat face/cross hole							

maxon Modular System		Page	Dimensions
maxon DC motor	Number of stages		
DCX 16 S	3-4	18-19	
DCX 16 L	3-4	20-21	
DCX 19 S	1-2	22-23	
DC-max 16 S	3-4	34-35	

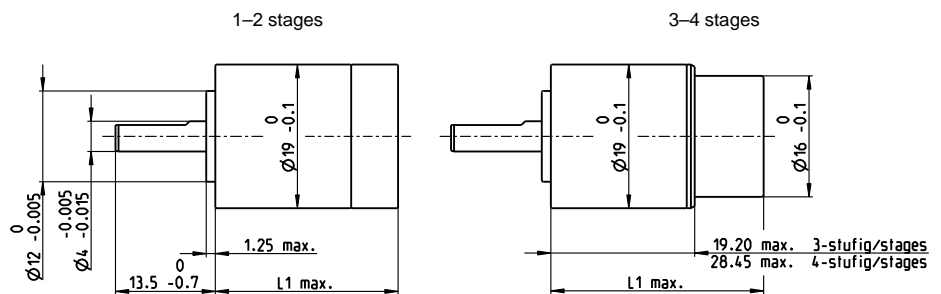

xdrives.maxonmotor.com

# GPX 22

## Planetary Gearhead Ø22 mm

**NEW**



Key Data	A Standard Version	C Ceramic Version
Max. transmittable power	W 24	30
Max. continuous torque	Nm 1.5	2
Max. continuous input speed	rpm 12000	12000
Ambient temperature	°C -40 ... +100	-40 ... +100
Bearing at output	Ball bearing	Ball bearing

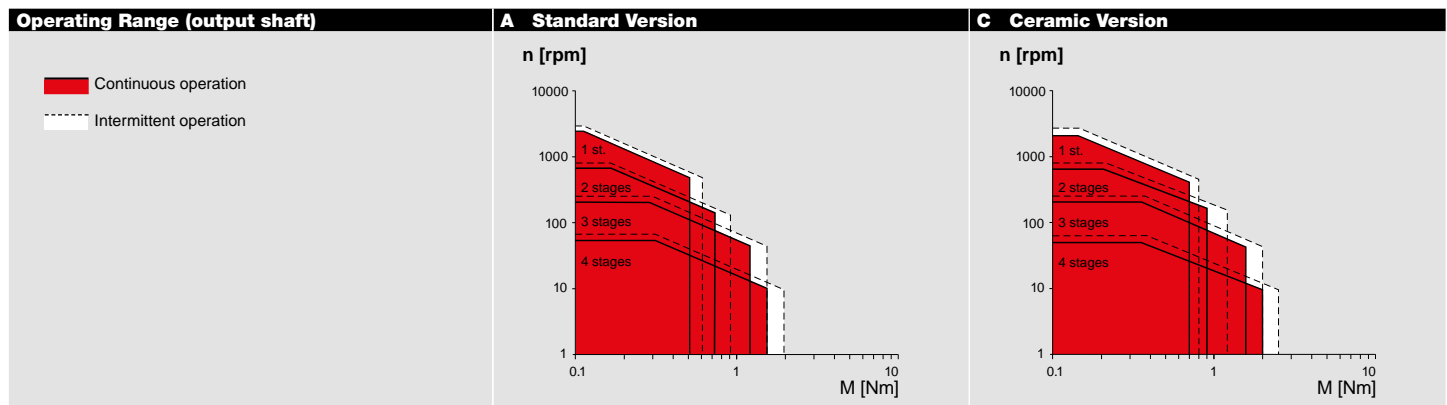

Specifications	A Standard Version	C Ceramic Version
Number of stages	1 2 3 4	1 2 3 4
Max. transmittable power (continuous)	W 24.0 12.0 6.0 1.6	30.0 15.0 7.0 2.0
Max. transmittable power (intermittent)	W 30.0 15.0 7.5 2.0	38.0 19.0 9.0 2.5
Max. continuous torque	Nm 0.50 0.70 1.20 1.50	0.70 0.90 1.60 2.00
Max. intermittent torque	Nm 0.60 0.90 1.50 1.90	0.80 1.20 2.00 2.50
Max. continuous input speed	rpm 8000 10000 12000 12000	8000 10000 12000 12000
Max. intermittent input speed	rpm 10000 12500 15000 15000	10000 12500 15000 15000
Max. efficiency	% 90 81 74 66	90 81 74 66
Average backlash no load	° 1.4 1.6 1.75 1.9	1.4 1.6 1.75 1.9
Max. axial load (dynamic)	N 40 40 40 40	40 40 40 40
Max. radial load, 10 mm from flange	N 65 100 120 120	65 100 120 120
Gearhead length L1	mm 19.9 26.4 32.2 43.0	19.9 26.4 32.2 43.0
Weight	g 45 58 67 89	45 58 67 89

Configuration	A Standard Version	C Ceramic Version	
Number of stages	1 2 3 4	1 2 3 4	
Reduction	X:1 3.9, 5.3, 6.6 16, 21, 26, 28, 35, 44 62, 83, 103, 111, 138, 150, 172, 186, 231 243, 326, 406, 439, 546, 590, 679, 734, 794, 913, 987, 1135, 1227, 1526	3.9, 5.3, 6.6 16, 21, 26, 28, 35, 44 62, 83, 103, 111, 138, 150, 172, 186, 231 243, 326, 406, 439, 546, 590, 679, 734, 794, 913, 987, 1135, 1227, 1526	
Version	Standard/ceramic version/noise reduced/backlash reduced/high power		
Flange	Standard flange/configurable flange		
Shaft	Length/flat face/cross hole		

maxon Modular System	Page	Dimensions
maxon DC motor	Number of stages	
DCX 19 S	3-4	22-23
DCX 22 S	1-2	24-25
DCX 22 L	1-2	26-27
DC-max 22 S	1-2	36-37

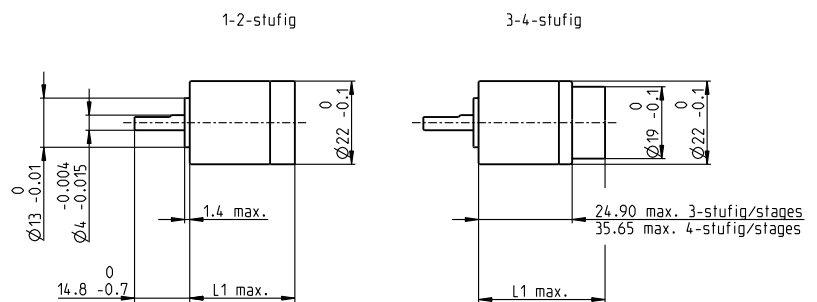

[xdrives.maxonmotor.com](http://xdrives.maxonmotor.com)



# GPX 22

## Planetary Gearhead Ø22 mm

**NEW**



Key Data	LN Noise Reduced	LZ Backlash Reduced
Max. transmittable power	W 20	12
Max. continuous torque	Nm 1.2	1.5
Max. continuous input speed	rpm 12000	12000
Ambient temperature	°C -40 ... +85	-40 ... +100
Bearing at output	Ball bearing	Ball bearing
Typical noise level	dBA -5 dBA compared to standard configuration	

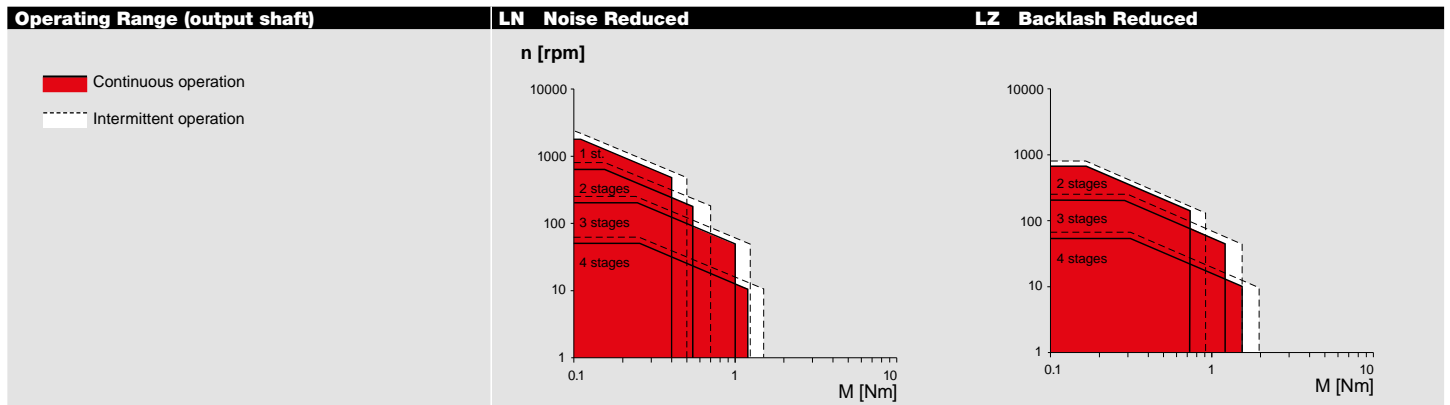

Specifications	LN Noise Reduced				LZ Backlash Reduced			
	1	2	3	4	2	3	4	
Number of stages								
Max. transmittable power (continuous)	W 20.0	10.0	5.0	1.3	12.0	6.0	1.6	
Max. transmittable power (intermittent)	W 25.0	13.0	6.3	1.6	15.0	7.5	2.0	
Max. continuous torque	Nm 0.40	0.55	1.00	1.20	0.70	1.20	1.50	
Max. intermittent torque	Nm 0.50	0.70	1.25	1.50	0.90	1.50	1.90	
Max. continuous input speed	rpm 8000	10000	12000	12000	10000	12000	12000	
Max. intermittent input speed	rpm 10000	12500	15000	15000	12500	15000	15000	
Max. efficiency	% 90	81	74	66	81	74	66	
Average backlash no load	° 1.4	1.6	1.75	1.9	1.1	1.2	1.4	
Max. axial load (dynamic)	N 40	40	40	40	40	40	40	
Max. radial load, 10 mm from flange	N 65	100	120	120	100	120	120	
Gearhead length L1	mm 19.9	26.4	32.2	43.0	26.4	32.2	43.0	
Weight	g 45	58	67	89	58	67	89	

Configuration	LN Noise Reduced				LZ Backlash Reduced			
	1	2	3	4	2	3	4	
Number of stages								
Reduction	X:1 3.9, 5.3, 6.6	16, 21, 26, 28, 35, 44	62, 83, 103, 111, 138, 150, 172, 186, 231	243, 326, 406, 439, 546, 590, 679, 734, 794, 913, 987, 1135, 1227, 1526	16, 21, 26, 28, 35, 44	62, 83, 103, 111, 138, 150, 172, 186, 231	243, 326, 406, 439, 546, 590, 679, 734, 794, 913, 987, 1135, 1227, 1526	
Version	Standard/ceramic version/noise reduced/backlash reduced/high power							
Flange	Standard flange/configurable flange							
Shaft	Length/flat face/cross hole							

maxon Modular System	Page	Dimensions
maxon DC motor		
DCX 19 S	3-4	22-23
DCX 22 S	1-2	24-25
DCX 22 L	1-2	26-27
DC-max 22 S	1-2	36-37

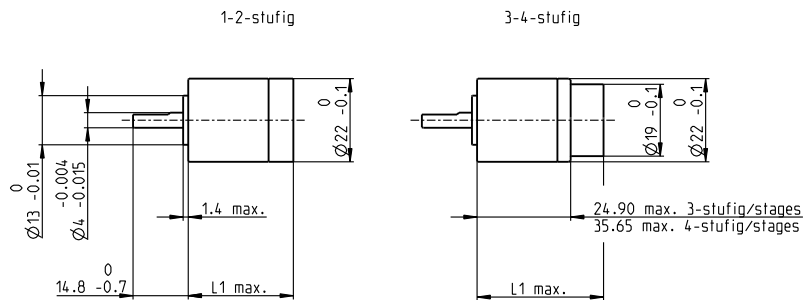

[xdrives.maxonmotor.com](http://xdrives.maxonmotor.com)

# GPX 22

## Planetary Gearhead Ø22 mm

**NEW**



Key Data		HP High Power
Max. transmittable power	W	30
Max. continuous torque	Nm	3.7
Max. continuous input speed	rpm	12000
Ambient temperature	°C	-40 ... +85
Bearing at output		Ball bearing

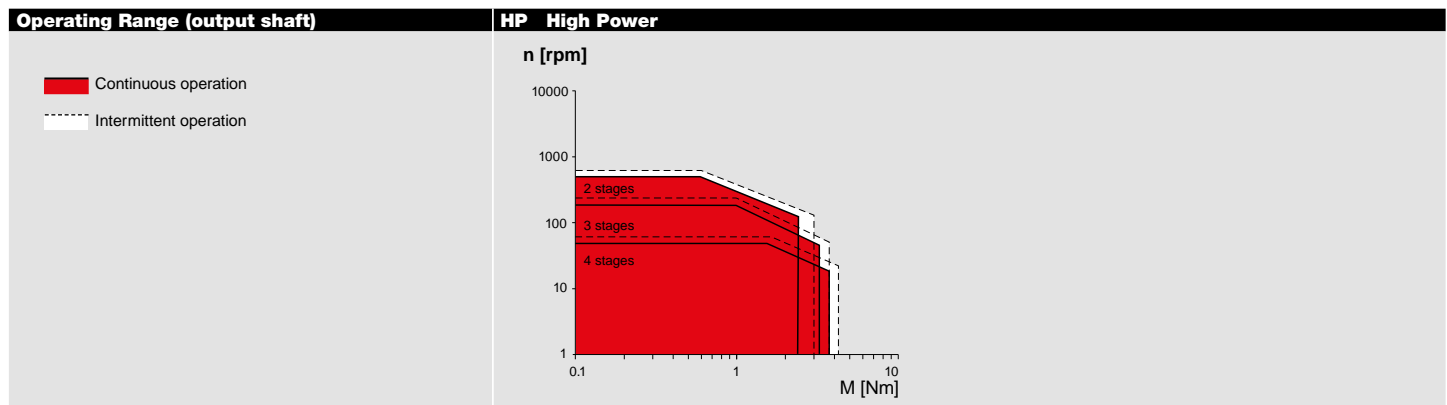

Specifications		HP High Power		
		2	3	4
Number of stages		2	3	4
Max. transmittable power (continuous)	W	30.0	15.0	8.0
Max. transmittable power (intermittent)	W	40.0	20.0	10.0
Max. continuous torque	Nm	2.40	3.30	3.70
Max. intermittent torque	Nm	3.00	3.80	4.20
Max. continuous input speed	rpm	8000	10000	12000
Max. intermittent input speed	rpm	10000	12500	15000
Max. efficiency	%	75	65	55
Average backlash no load	°	1.6	1.75	1.9
Max. axial load (dynamic)	N	80	80	80
Max. radial load, 5 mm from flange	N	145	150	150
Gearhead length L1	mm	31.7	38.2	44.0
Weight	g	73	86	95

Configuration		HP High Power		
		2	3	4
Number of stages		2	3	4
Reduction	X:1	16, 21, 26, 28, 35, 44	62, 83, 103, 111, 138, 150, 172, 186, 231	243, 326, 406, 439, 546, 590, 679, 734, 794, 913, 987, 1135, 1227, 1526
Version		Standard/ceramic version/noise reduced/backlash reduced/high power		
Flange		Standard flange/configurable flange		
Shaft		Length/flat face/cross hole		

maxon Modular System		Page
maxon DC motor	Number of stages	
DCX 19 S	4	22–23
DCX 22 S	2–3	24–25
DCX 22 L	2–3	26–27

### Dimensions M 1:2

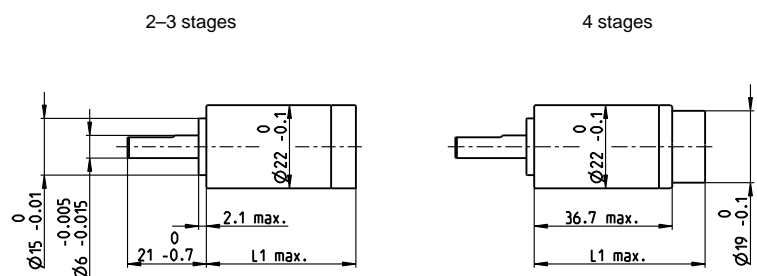

[xdrives.maxonmotor.com](http://xdrives.maxonmotor.com)

# GPX 26

## Planetary Gearhead Ø26 mm

**NEW**



Key Data	A Standard Version	C Ceramic Version
Max. transmittable power	W 48	55
Max. continuous torque	Nm 2.25	3.0
Max. continuous input speed	rpm 8000	8000
Ambient temperature	°C -40 ... +100	-40 ... +100
Bearing at output	Ball bearing	Ball bearing

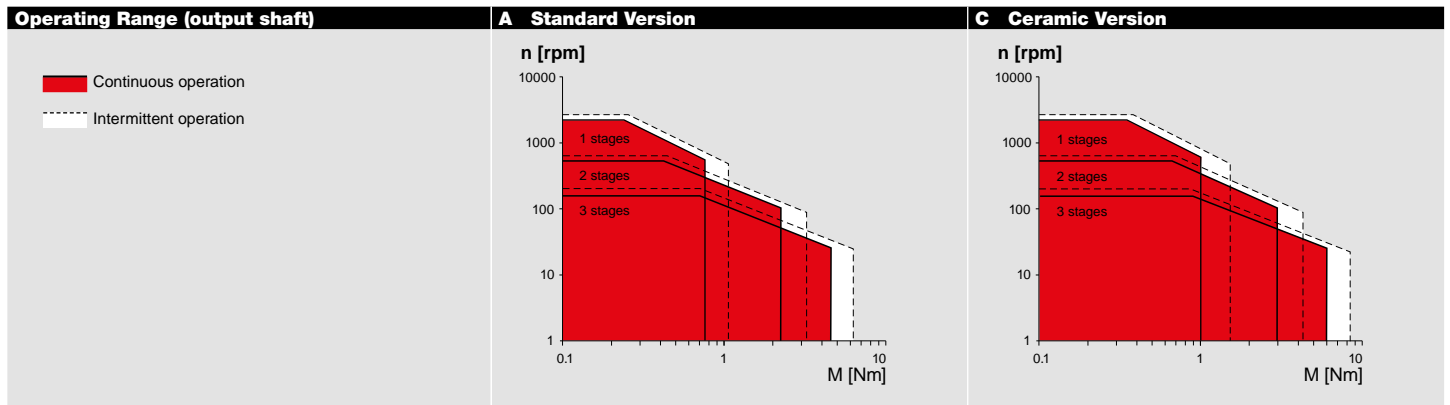

Specifications	A Standard Version			C Ceramic Version		
Number of stages	1	2	3	1	2	3
Max. transmittable continuous power	W 48	24	12.0	55	30	15.0
Max. transmittable intermittent power	W 60	30	15.0	70	35	18.0
Max. continuous torque	Nm 0.75	2.25	4.50	1.00	3.00	6.00
Max. intermittent torque	Nm 1.10	3.20	6.20	1.50	4.25	8.25
Max. continuous input speed	rpm 7000	8000	10000	7000	8000	10000
Max. intermittent input speed	rpm 8750	10000	12500	8750	10000	12500
Max. efficiency	% 90	78	75	90	78	75
Average backlash no load	° 1.2	1.3	1.60	1.2	1.3	1.60
Max. axial load (dynamic)	N 80	80	80	80	80	80
Max. radial load, 10 mm from flange	N 95	145	150	95	145	150
Gearhead length L1	mm 21.3	30.2	35.6	21.3	30.2	35.6
Weight	g 75	95	105	75	95	105

Configuration	A Standard Version			C Ceramic Version		
Number of stages	1	2	3	1	2	3
Reduction	X:1 3.9, 5.3, 6.6	16, 21, 26, 28, 35	62, 83, 103, 111, 138, 150, 172, 186, 231	3.9, 5.3, 6.6	16, 21, 26, 28, 35	62, 83, 103, 111, 138, 150, 172, 186, 231
Version	Standard/ceramic version/noise reduced/reduced backlash					
Flange	Standard flange/configurable flange					
Shaft	Length/flat face/cross hole					

maxon Modular System	Page	Dimensions
maxon DC motor	Number of stages	
DCX 22 S	3	24-25
DCX 22 L	3	26-27
DCX 26 L	1-2	28-29
DC-max 22 S	3	36-37

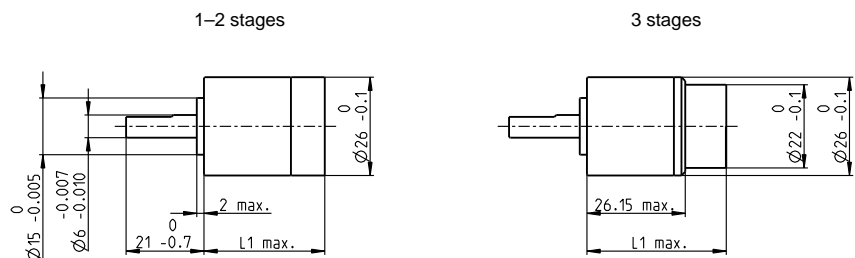

[xdrives.maxonmotor.com](http://xdrives.maxonmotor.com)

# GPX 26

## Planetary Gearhead Ø26 mm

**NEW**



Key Data	LN Noise Reduced	LZ Backlash Reduced
Max. transmittable power	W 38	24
Max. continuous torque	Nm 1.8	2.3
Max. continuous input speed	rpm 8000	8000
Ambient temperature	°C -40 ... +85	-40 ... +100
Bearing at output	Ball bearing	Ball bearing
Typical noise level	dBA -5 dBA compared to standard configuration	

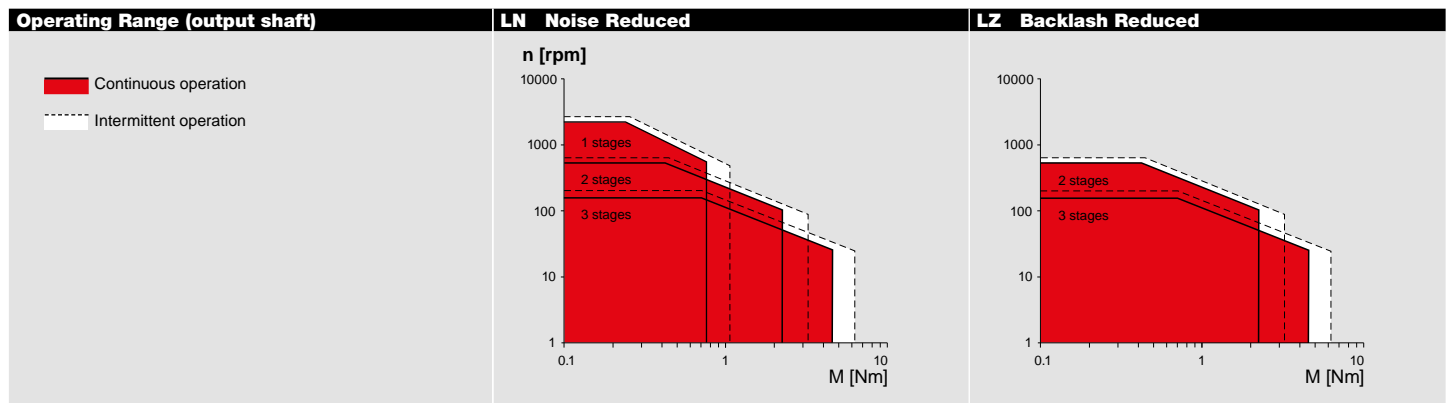

Specifications	LN Noise Reduced	LZ Backlash Reduced
Number of stages	1      2      3	2      3
Max. transmittable continuous power	W 38      19      10.0	24      12.0
Max. transmittable intermittent power	W 48      24      12.0	30      15.0
Max. continuous torque	Nm 0.60      1.80      3.60	2.25      4.50
Max. intermittent torque	Nm 0.75      2.25      4.50	3.20      6.20
Max. continuous input speed	rpm 7000      8000      10000	8000      10000
Max. intermittent input speed	rpm 8750      10000      12500	10000      12500
Max. efficiency	% 90      78      75	78      75
Average backlash no load	° 1.2      1.3      1.60	0.7      0.80
Max. axial load (dynamic)	N 80      80      80	80      80
Max. radial load, 10 mm from flange	N 95      145      150	145      150
Gearhead length L1	mm 21.3      30.2      35.5	30.2      35.5
Weight	g 75      95      105	95      105

Configuration	LN Noise Reduced	LZ Backlash Reduced
Number of stages	1      2      3	2      3
Reduction	X:1 3.9, 5.3, 6.6      16, 21, 26, 28, 35      62, 83, 103, 111, 138, 150, 172, 186, 231	16, 21, 26, 28, 35      62, 83, 103, 111, 138, 150, 172, 186, 231
Version	Standard/ceramic version/noise reduced/backlash reduced	
Flange	Standard flange/configurable flange	
Shaft	Length/flat face/cross hole	

maxon Modular System	Page	Dimensions
maxon DC motor	Number of stages	
DCX 22 S	3	24-25
DCX 22 L	3	26-27
DCX 26 L	1-2	28-29
DC-max 22 S	3	36-37

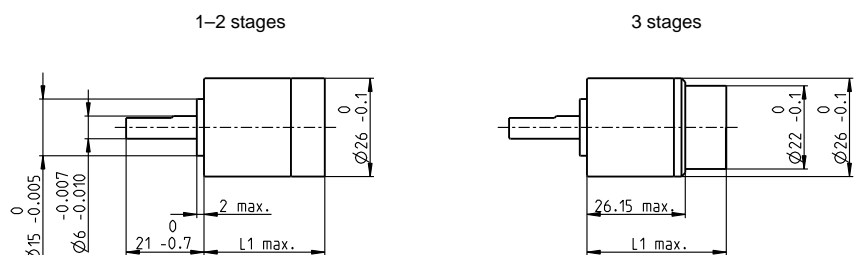

[xdrives.maxonmotor.com](http://xdrives.maxonmotor.com)



# GPX 32

## Planetary Gearhead Ø32 mm



Key Data	A Standard Version	C Ceramic Version
Max. transmittable power	W 100	120
Max. continuous torque	Nm 5	6.6
Max. continuous input speed	rpm 8000	8000
Ambient temperature	°C -40 ... +100	-40 ... +100
Bearing at output	Ball bearing	Ball bearing

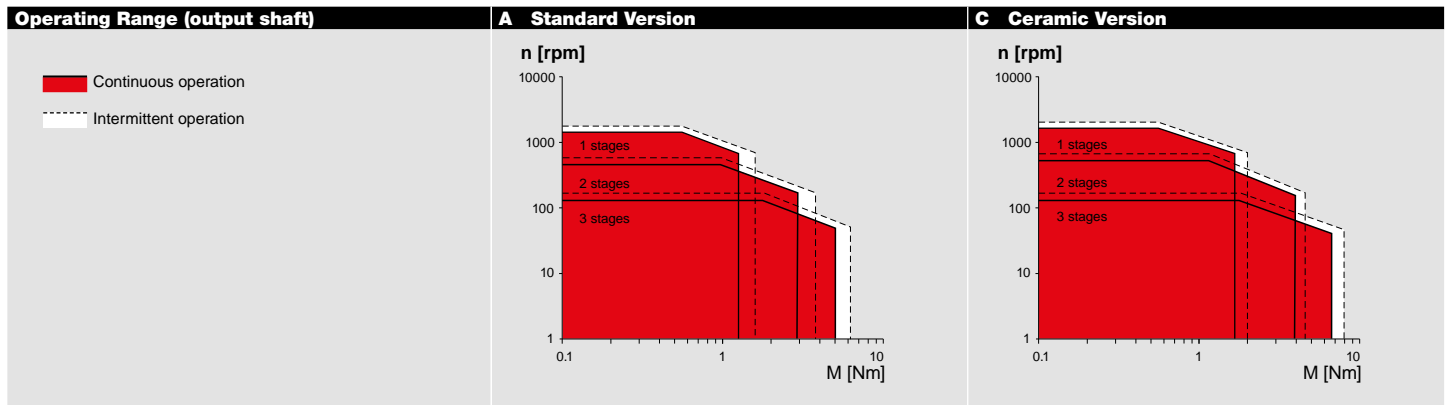

Specifications	A Standard Version			C Ceramic Version		
Number of stages	1	2	3	1	2	3
Max. transmittable continuous power	W 100	50	25	120	60	30
Max. transmittable intermittent power	W 125	62	31	150	75	37
Max. continuous torque	Nm 1.25	2.90	5.00	1.60	3.80	6.60
Max. intermittent torque	Nm 1.60	3.60	6.25	2.00	4.50	8.00
Max. continuous input speed	rpm 6000	7000	8000	6000	7000	8000
Max. intermittent input speed	rpm 7500	8750	10000	7500	8750	10000
Max. efficiency	% 90	78	75	90	78	75
Average backlash no load	° 1.4	1.5	1.7	1.4	1.5	1.7
Max. axial load (dynamic)	N 110	110	110	110	110	110
Max. radial load, 10 mm from flange	N 160	180	180	160	180	180
Gearhead length L1	mm 26.7	36.3	43.9	26.7	36.3	43.9
Weight	g 140	185	230	140	185	230

Configuration	A Standard Version			C Ceramic Version		
Number of stages	1	2	3	1	2	3
Reduction X:1	3.9, 5.3	16, 21, 26, 28, 35	62, 83, 103, 111, 138, 150, 172, 186, 231	3.9, 5.3	16, 21, 26, 28, 35	62, 83, 103, 111, 138, 150, 172, 186, 231
Version	Standard/ceramic version/noise reduced/backlash reduced/high power					
Flange	Standard flange/configurable flange					
Shaft	Length/flat face/cross hole					

maxon Modular System	Page	Dimensions
maxon DC motor	Number of stages	
DCX 26 L	3	28-29
DCX 32 L	1-2	30

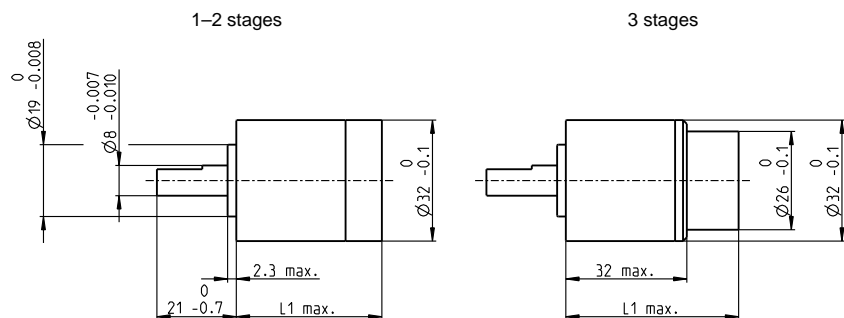

xdrives.maxonmotor.com

# GPX 32

## Planetary Gearhead Ø32 mm



Key Data	LN Noise Reduced	LZ Backlash Reduced
Max. transmittable power	W 80	50
Max. continuous torque	Nm 4	5
Max. continuous input speed	rpm 8000	8000
Ambient temperature	°C -40 ... +100	-40 ... +100
Bearing at output	Ball bearing	Ball bearing
Typical noise level	dBA -5 dBA compared to standard configuration	

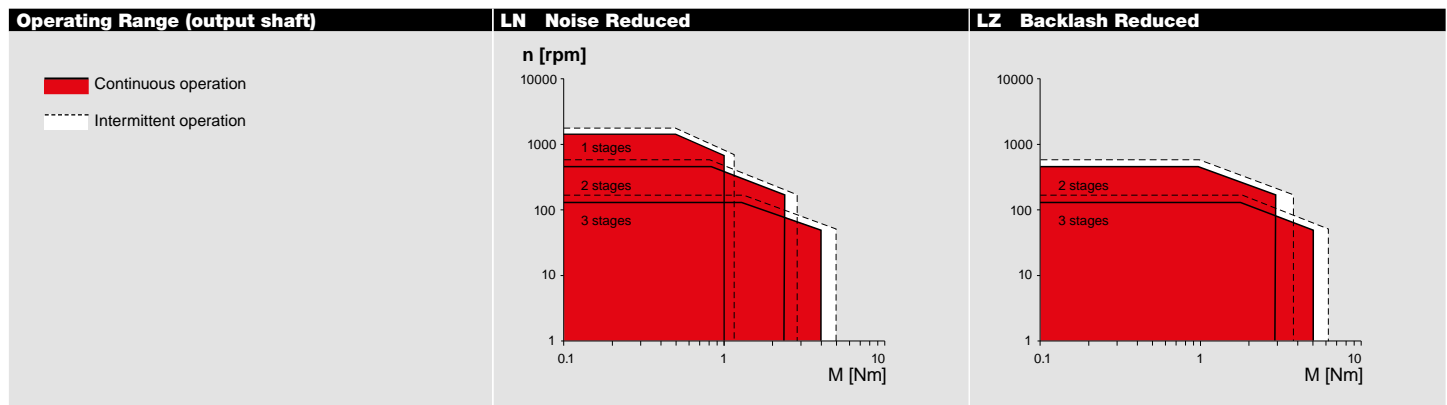

Specifications	LN Noise Reduced	LZ Backlash Reduced
Number of stages	1      2      3	2      3
Max. transmittable continuous power	W 80      40      20	50      25
Max. transmittable intermittent power	W 100      50      25	62      31
Max. continuous torque	Nm 1.00      2.30      4.00	2.90      5.00
Max. intermittent torque	Nm 1.30      2.90      5.00	3.60      6.25
Max. continuous input speed	rpm 6000      7000      8000	7000      8000
Max. intermittent input speed	rpm 7500      8750      10000	8750      10000
Max. efficiency	% 90      78      75	78      75
Average backlash no load	° 1.4      1.5      1.7	0.8      1.0
Max. axial load (dynamic)	N 110      110      110	110      110
Max. radial load, 10 mm from flange	N 160      180      180	180      180
Gearhead length L1	mm 26.7      36.3      43.9	36.3      43.9
Weight	g 140      185      230	185      230

Configuration	LN Noise Reduced	LZ Backlash Reduced
Number of stages	1      2      3	2      3
Reduction	X:1 3.9, 5.3      16, 21, 26, 28, 35      62, 83, 103, 111, 138, 150, 172, 186, 231	16, 21, 26, 28, 35      62, 83, 103, 111, 138, 150, 172, 186, 231
Version	Standard/ceramic version/noise reduced/backlash reduced/high power	
Flange	Standard flange/configurable flange	
Shaft	Length/flat face/cross hole	

maxon Modular System	Page	Dimensions
maxon DC motor	Number of stages	
DCX 26 L	3	28–29
DCX 32 L	1–2	30

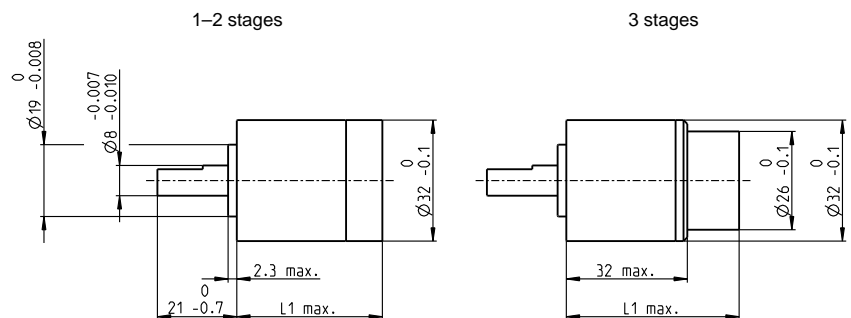

xdrives.maxonmotor.com

# GPX 32

## Planetary Gearhead Ø32 mm

**NEW**



Key Data		HP High Power	
Max. transmittable power	W	110	
Max. continuous torque	Nm	9	
Max. continuous input speed	rpm	8000	
Ambient temperature	°C	-40 ... +100	
Bearing at output		Ball bearing	

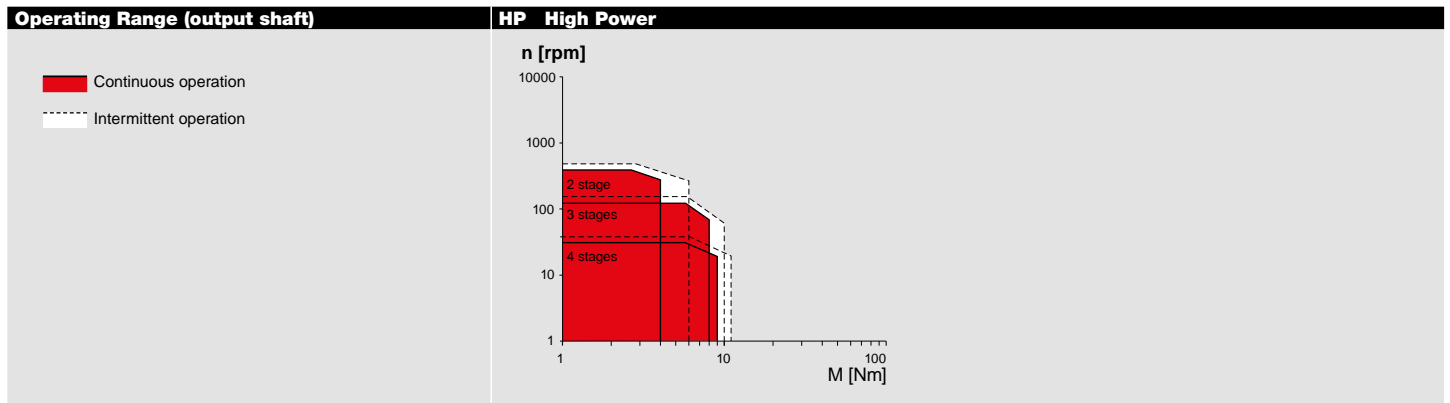

Specifications		HP High Power			
		2	3	4	
Number of stages		2	3	4	
Max. transmittable power (continuous)	W	110	55	18.0	
Max. transmittable power (intermittent)	W	140	70	25.0	
Max. continuous torque	Nm	4.00	8.00	9.00	
Max. intermittent torque	Nm	6.00	10.00	12.00	
Max. continuous input speed	rpm	6000	7000	8000	
Max. intermittent input speed	rpm	7500	8750	10000	
Max. efficiency	%	76	65	55	
Average backlash no load	°	1.5	1.7	2.0	
Max. axial load (dynamic)	N	110	110	110	
Max. radial load, 5 mm from flange	N	200	250	250.0	
Gearhead length L1	mm	46.3	55.9	63.5	
Weight	g	200	220	250	

Configuration		HP High Power			
		2	3	4	
Number of stages		2	3	4	
Reduction	X:1	16, 21, 26, 28, 35	62, 83, 103, 111, 138, 150, 172, 186, 231	243, 326, 406, 439, 546, 590, 679, 734, 794, 913, 987, 1135, 1227, 1526	
Version		Standard/ceramic version/noise reduced/backlash reduced/high power			
Flange		Standard flange/configurable flange			
Shaft		Length/flat face/feather key			

maxon Modular System		Page	Dimensions	M 1:2
maxon DC motor	Number of stages			
DCX 26 L	4	28–29		
DCX 32 L	2–3	30		

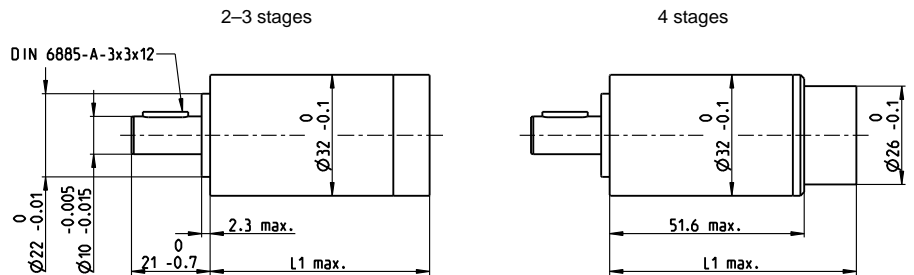

[xdrives.maxonmotor.com](http://xdrives.maxonmotor.com)

# GPX 37

## Planetary Gearhead Ø37 mm



Key Data		A Standard Version	
Max. transmittable power	W	185	
Max. continuous torque	Nm	9.3	
Max. continuous input speed	rpm	7000	
Ambient temperature	°C	-40 ... +100	
Bearing at output		Ball bearing	

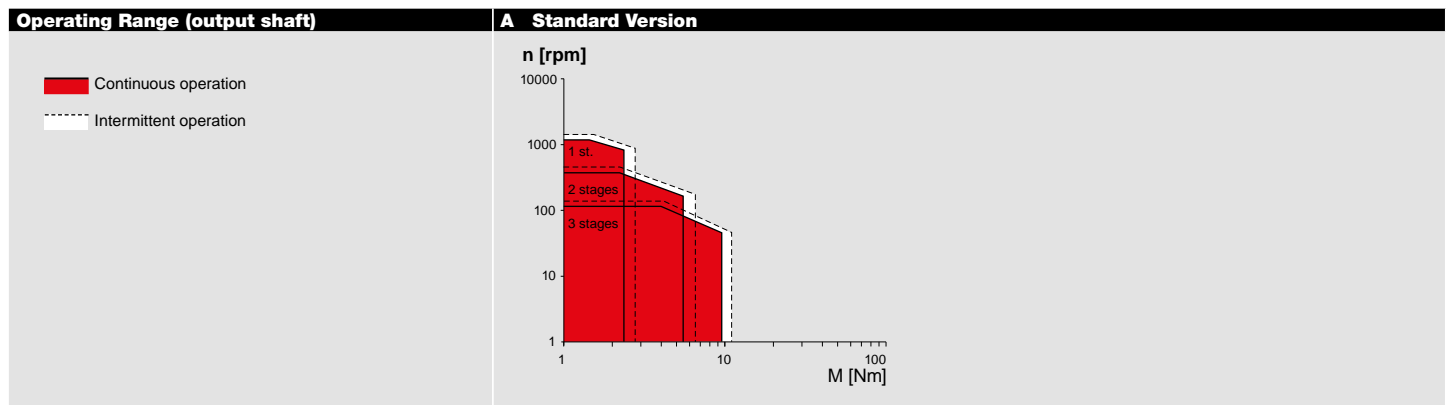

Specifications		A Standard Version		
		1	2	3
Number of stages		1	2	3
Max. transmittable continuous power	W	185	90	45
Max. transmittable intermittent power	W	230	115	60
Max. continuous torque	Nm	2.30	5.40	9.30
Max. intermittent torque	Nm	2.90	6.80	11.60
Max. continuous input speed	rpm	5000	6000	7000
Max. intermittent input speed	rpm	6250	7500	8750
Max. efficiency	%	90	80	75
Average backlash no load	°	1.4	1.5	1.7
Max. axial load (dynamic)	N	240	240	240
Max. radial load, 10 mm from flange	N	200	250	250
Gearhead length L1	mm	35.4	48.3	52.9
Weight	g	230	310	410

Configuration		A Standard Version		
		1	2	3
Number of stages		1	2	3
Reduction	X:1	3.9	16, 26	62, 83, 103, 111, 138, 150, 172, 186, 231
Version		Standard/noise reduced/reduced backlash		
Flange		Standard flange/configurable flange		
Shaft		Length/flat face/feather key		

maxon DC motor		Page	Dimensions		M 1:2
maxon DC motor	Number of stages				
DCX 32 L	3	30			
DCX 35 L	1-2	31			

xdrives.maxonmotor.com

# GPX 37

## Planetary Gearhead Ø37 mm



Key Data	LN Noise Reduced	LZ Backlash Reduced
Max. transmittable power	W 150	90
Max. continuous torque	Nm 7.4	9.3
Max. continuous input speed	rpm 7000	7000
Ambient temperature	°C -40 ... +85	-40 ... +100
Bearing at output	Ball bearing	Ball bearing
Typical noise level	dBA -5 dBA compared to standard configuration	

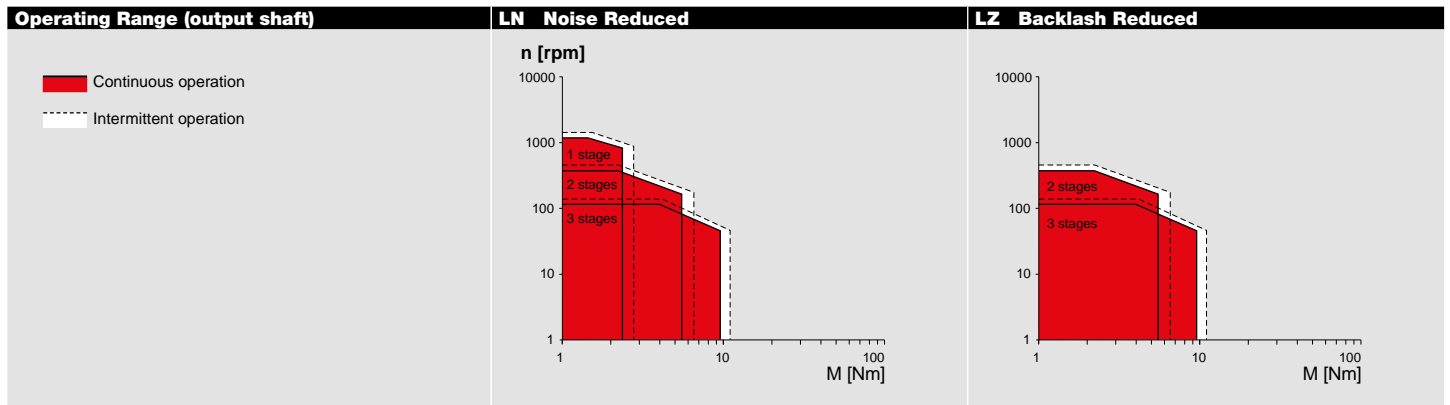

Specifications	LN Noise Reduced			LZ Backlash Reduced	
Number of stages	1	2	3	2	3
Max. transmittable continuous power	W 150	75	37	90	45
Max. transmittable intermittent power	W 185	90	45	115	60
Max. continuous torque	Nm 1.85	4.30	7.40	5.40	9.30
Max. intermittent torque	Nm 2.30	5.40	9.20	6.80	11.60
Max. continuous input speed	rpm 5000	6000	7000	6000	7000
Max. intermittent input speed	rpm 6250	7500	8750	7500	8750
Max. efficiency	% 90	80	75	80	75
Average backlash no load	° 1.4	1.5	1.7	0.8	1.0
Max. axial load (dynamic)	N 240	240	240	240	240
Max. radial load, 10 mm from flange	N 200	250	250	250	250
Gearhead length L1	mm 35.4	48.3	52.9	48.3	52.9
Weight	g 230	310	410	310	410

Configuration	LN Noise Reduced			LZ Backlash Reduced	
Number of stages	1	2	3	2	3
Reduction	X:1	3.9, 16, 26	62, 83, 103, 111, 138, 150, 172, 186, 231	16, 26	62, 83, 103, 111, 138, 150, 172, 186, 231
Version	Standard/noise reduced/backlash reduced				
Flange	Standard flange/configurable flange				
Shaft	Length/flat face/feather key				

maxon Modular System	Page	Dimensions	M 1:2
maxon DC motor	Number of stages		
DCX 32 L	3	30	
DCX 35 L	1-2	31	

xdrives.maxonmotor.com





# maxon ENX

## Encoder

### maxon ENX

maxon ENX encoders make an impression with their robust design and high signal quality. The 3-channel encoder with differential signals guarantees interference-free function even under the highest loads. The resolution can be factory-set. EASY is an incremental or absolute encoder based on the Hall effect. With the QUAD you get a 1-count encoder for rotation direction and speed recognition.

maxon ENX encoders can be configured online and are ready for delivery within 11 working days.

[enx.maxonmotor.com](http://enx.maxonmotor.com)



**maxon motor**

driven by precision



# ENX 8 Absolute

## Encoder Ø8 mm, 4096 steps

NEW



Key Data	EASY Absolute	EASY Absolute, Commutation Signal
Steps per turn	4096	4096
Resolution (bit single turn)	12	12
Encoder length L max.	mm (integrated into motor)	(integrated into motor)
Ambient temperature <sup>1</sup>	°C -20...100 (-40...100)	-20...100 (-40...100)
Weight	g <4	<4

Selection criteria	EASY Absolute	EASY Absolute, Commutation Signal
Speed and rotation direction detection	■	■
Speed and position control	■	■
Compact and robust design	■	■
High resolution	■	■
Cost effective	■	■

■ suitable ▲ suitable to a limited extent ● not suitable

Specifications	EASY Absolute	EASY Absolute, Commutation Signal
Supply voltage V <sub>cc</sub>	V 5 ±0.5	5 ±0.5
Max. operating frequency	kHz 80000	80000
Connector <sup>2</sup>	10-pin 1.27 mm multipoint connector e.g. Samtec FTSH series Pin 1: Data Pin 2: V <sub>cc</sub> 4.5...5.5 Pin 3: GND Pin 4: CLK Pin 5: Do not connect (A̅) Pin 6: Do not connect (A) Pin 7: Do not connect (B̅) Pin 8: Do not connect (B) Pin 9: Do not connect (I) Pin 10: Do not connect (I) Output signal: EIA-Standard RS 422 Output current per channel: ± 20 mA	10-pin 1.27 mm multipoint connector e.g. Samtec FTSH series Pin 1: Data Pin 2: V <sub>cc</sub> 4.5...5.5 Pin 3: GND Pin 4: CLK Pin 5: H1 Pin 6: Do not connect (A) Pin 7: H2 Pin 8: Do not connect (B) Pin 9: H3 Pin 10: Do not connect (I) Output signal: CMOS compatible Output current per channel: + 20 mA

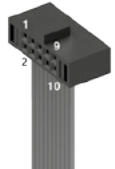
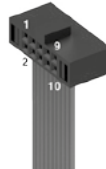

Configuration	EASY Absolute	EASY Absolute, Commutation Signal
Signal protocol	BiSS-C, SSI	BiSS-C, SSI
Cable length	mm 50, 100, 150, 200, 250, 300	50, 100, 150, 200, 250, 300
Cable insulation <sup>1</sup>	PVC/PO/FEP	PVC/PO/FEP
Alignment of cable outlet in relation to motor flange	° axial	axial

maxon Modular System	Page	Dimensions Standard Version	M 3:4	Notes
maxon EC motor				
ECX 8	28			

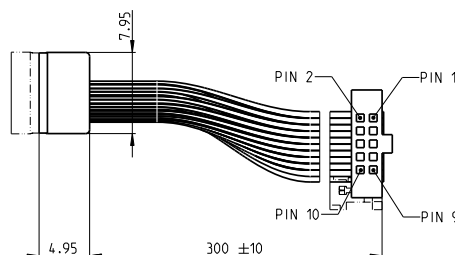

<sup>1</sup> For PVC-cable (-20...100°C)  
For PO- and FEP cable (-40...100°C)  
<sup>2</sup> H1, index and angle zero are aligned with angle commutation zero (see p. 32).

xdrives.maxonmotor.com

# ENX 10

## Encoder Ø10 mm



Key Data	EASY	QUAD
Number of channels	3	2
Max. counts per turn	1024	1
Encoder length L max.	mm 8.5	9
Ambient temperature	°C -40 ... +100	-40 ... +100
Weight	g <5	<5

Selection criteria	EASY	QUAD
Speed and rotation direction detection	■	■
Speed and position control	■	▲
Compact and robust design	■	■
High resolution	■	●
Cost effective	■	■

■ suitable    ▲ suitable to a limited extent    ● not suitable

Specifications	EASY	QUAD
Supply voltage V <sub>cc</sub>	V 5 ±0.5	5 ±0.5
Max. operating frequency	kHz 500	2
Max. Speed	rpm 30000	30000
Connector	10-pin 1.27 mm multipoint connector e.g. Samtec FTSH series	10-pin 2.54 mm multipoint connector <sup>3</sup> (IEC/EN 60603-1-DIN41651)
	Pin 1: Do not connect <sup>1</sup> Pin 2: V <sub>CC</sub> Pin 3: GND Pin 4: Do not connect <sup>1</sup> Pin 5: Channel A Pin 6: Channel A Pin 7: Channel B Pin 8: Channel B Pin 9: Channel I Pin 10: Channel I	Pin 1: Not connected Pin 2: V <sub>CC</sub> Pin 3: Channel A Pin 4: Channel B Pin 5: GND Pin 6: Not connected Pin 7: Not connected Pin 8: Not connected Pin 9: Not connected Pin 10: Not connected

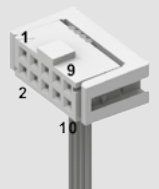
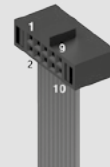

Configuration	EASY	QUAD
Counts per turn <sup>2</sup>	1 ... 1024	1
Cable length	mm 50, 100, 150, 200, 300, 500, 1000	50, 100, 150, 200, 300, 500, 1000
Alignment of cable outlet in relation to motor flange	° 15	15

maxon Modular System	Page	Dimensions Standard Configuration	M 1:1	Notes
<b>maxon DC motor</b>				
DCX 10 S	EASY, QUAD	12		
DCX 10 L	EASY, QUAD	13		
DCX 12 S	EASY, QUAD	14		
DCX 12 L	EASY, QUAD	15		
DCX 14 L	EASY, QUAD	16–17		
DCX 16 S	EASY, QUAD	18–19		
DCX 16 L	EASY, QUAD	20–21		
DCX 19 S	QUAD	22–23		
DCX 22 S	QUAD	24–25		
DCX 22 L	QUAD	26–27		
DCX 26 L	QUAD	28–29		
DCX 32 L	QUAD	30		
DCX 35 L	QUAD	31		
DC-max 16 S	EASY, QUAD	34–35		
DC-max 22 S	EASY, QUAD	36–37		

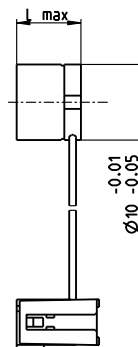

<sup>1</sup> Applying voltage to these pins can destroy the encoder.  
<sup>2</sup> maxon controllers require a resolution of at least 16 counts per turn.  
<sup>3</sup> Option: 6-pol 2.54 mm pin header.



# ENX 16

## Encoder Ø16 mm



Key Data		EASY
Number of channels		3
Max. counts per turn		1024
Encoder length L max.	mm	8.5
Ambient temperature	°C	-40 ... +100
Weight	g	7

Selection criteria		EASY
Speed and rotation direction detection		■
Speed and position control		■
Compact and robust design		■
High resolution		■
Cost effective		■

■ suitable    ▲ suitable to a limited extent    ● not suitable

Specifications		EASY
Supply voltage V <sub>cc</sub>	V	5 ±0.5
Max. operating frequency	kHz	500
Max. Speed	rpm	30000
Connector		10-pin 2.54 mm multipoint connector (IEC/EN 60603-1-DIN41651) Pin 1: N.C. Pin 2: V <sub>cc</sub> Pin 3: GND Pin 4: N.C. Pin 5: Channel $\bar{A}$ Pin 6: Channel A Pin 7: Channel $\bar{B}$ Pin 8: Channel B Pin 9: Channel $\bar{I}$ Pin 10: Channel I

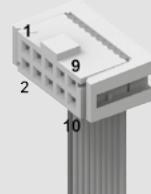

Configuration		EASY
Counts per turn <sup>1</sup>		1 ... 1024
Cable length	mm	50, 100, 150, 200, 300, 500, 1000
Alignment of cable outlet in relation to motor flange	°	15

maxon Modular System	Page	Dimensions Standard Version	M 3:4	Notes
<b>maxon DC motor</b>				
DCX 16 S	18–19			<sup>1</sup> maxon controllers require a resolution of at least 16 counts per turn.
DCX 16 L	20–21			
DCX 19 S	22–23			
DCX 22 S	24–25			
DCX 22 L	26–27			
DCX 26 L	28–29			
DCX 32 L	30			
DCX 35 L	31			

[xdrives.maxonmotor.com](http://xdrives.maxonmotor.com)

# ENX 16 Absolute

## Encoder Ø16 mm



Key Data	EASY Absolute	
Steps per turn	4096	
Resolution (bit single turn)	12	
Encoder length L max.	mm 8.5	
Ambient temperature	°C -40 ... +100	
Weight	g 7	

Selection criteria	EASY Absolute	
Speed and rotation direction detection	■	
Speed and position control	■	
Compact and robust design	■	
High resolution	■	
Cost effective	■	

■ suitable    ▲ suitable to a limited extent    ● not suitable

Specifications	EASY Absolute	
Supply voltage Vcc	V 5 ±0.5	
Max. Speed	rpm 30000	
Connector	10-pin 2.54 mm multipoint connector (IEC/EN 60603-1-DIN41651) Pin 1: Data Pin 2: V <sub>CC</sub> Pin 3: GND Pin 4: CLK Pin 5: Do not connect (A) Pin 6: Do not connect (A) Pin 7: Do not connect (B) Pin 8: Do not connect (B) Pin 9: Do not connect (I) Pin 10: Do not connect (I)	

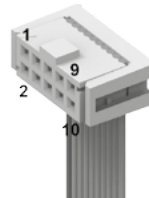

Configuration	EASY Absolute	
Signal protocol	BiSS-C, SSI	
Cable length	mm 50, 100, 150, 200, 300, 500, 1000	
Alignment of cable outlet in relation to motor flange	° 15	

maxon Modular System	Page	Dimensions Standard Version	M 3:4	Notes
<b>maxon DC motor</b>				
DCX 16 S	18–19			Adapter EASY Absolute (Part number 488167) required for all maxon controllers.
DCX 16 L	20–21			
DCX 19 S	22–23			
DCX 22 S	24–25			
DCX 22 L	26–27			
DCX 26 L	28–29			
DCX 32 L	30			
DCX 35 L	31			

xdrives.maxonmotor.com

# maxon motor control

## Electronics

## maxon motor control

These control electronics have been designed for optimum compatibility with maxon motors. A range of 4-quadrant servo amplifiers and position controllers cover all requirements related to power, speed precision, positioning accuracy and controlled rotary motion. More information on maxon motor control can be found in our main catalog "maxon Program", as well as at [www.maxonmotor.com](http://www.maxonmotor.com).

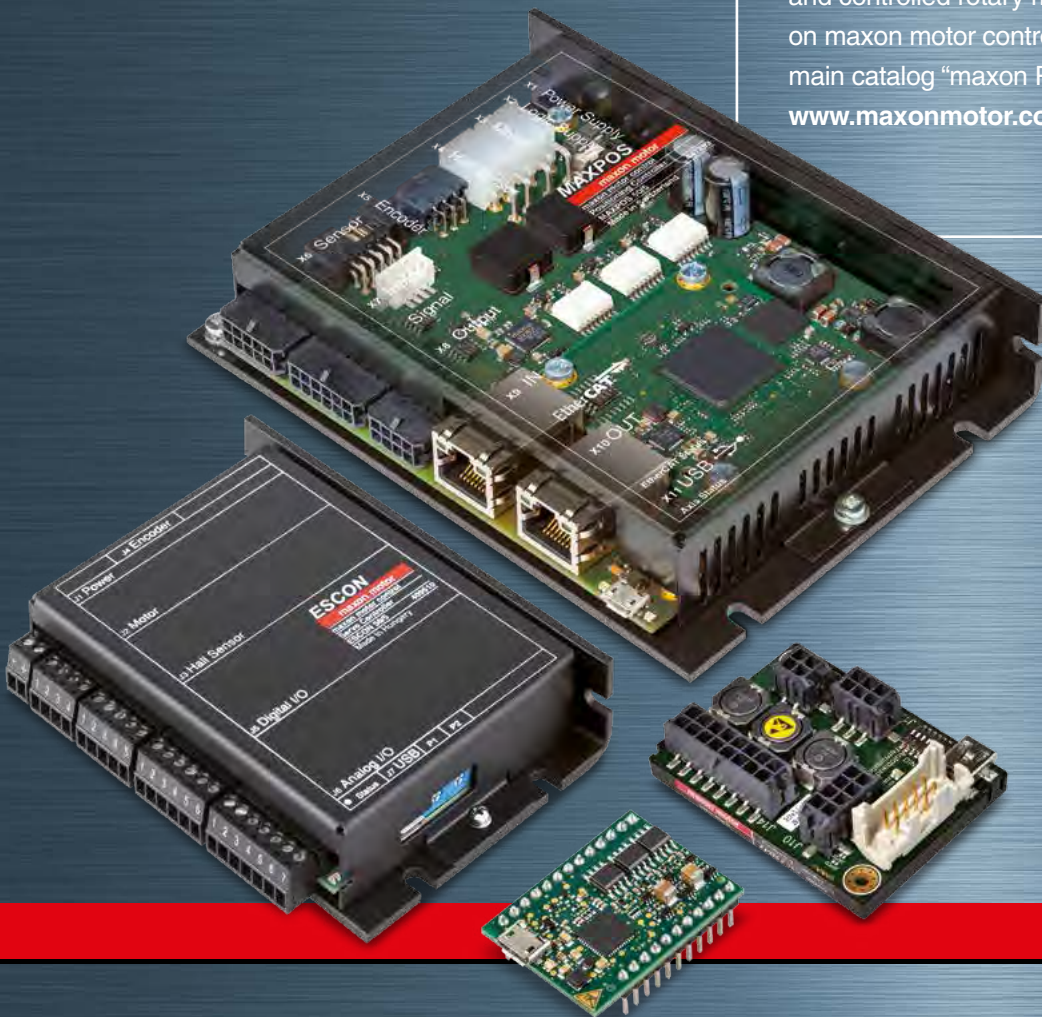

**maxon motor**

driven by precision

## ESCON Servo Controller

The ESCON servo controllers are compact, powerful 4-quadrant PWM servo controllers for efficient control of permanent magnet-activated DC motors. The available operating modes – speed controller (closed loop), speed controller (open loop) and current controller – satisfy the most demanding requirements. The ESCON servo controllers are designed to be controlled using an analog set value.

ESCON Servokontroller	Beschreibung
ESCON Module 24/2	For DC and EC motors up to 48 W
ESCON 36/2 DC	For DC motors up to 72 W
ESCON 36/3 EC	For EC motors up to 97 W
ESCON Module 50/4 EC-S	For sensorless EC motors up to 200 W
ESCON Module 50/5	For DC and EC motors up to 250 W
ESCON 50/5	For DC and EC motors up to 250 W
ESCON 70/10	For DC and EC motors up to 700 W

## 1-Q-EC Amplifier

The basic function of EC motors electronics is the electronic commutation of the motor winding. Simple speed controls are possible with Hall sensors. A further distinction is made between open or closed loop speed control. 1-Q amplifier functions in motor operation. Direction reverse via digital signal.

1-Q-EC Amplifier	Description
DEC Module 24/2	For EC motors up to 48 W
DEC Module 50/5	For EC motors up to 250 W

## EPOS2 P Programmable Positioning Controller

EPOS2 P is a freely programmable positioning controller with an integrated power stage, based on the EPOS2 slave version. It is suitable for brushless and brush DC motors with incremental encoder and up to 120 watt output.

EPOS2 P Programmable Positioning Controller	Description
EPOS2 P 24/5	For DC and EC motors bis 120 W

## EPOS2 Positioning Control Units

If a drive system's control requirements go beyond just speed and torque controls and if repeated positioning processes are required in complex paths of motion, positioning controls can be used. The EPOS2 (Easy to use Positioning System) provides a modular product range for DC and EC motors.

EPOS2 Positioning Control Units	Description
EPOS2 24/2 (DC/EC)	For DC and EC motors up to 48 W
EPOS2 Module 36/2	For DC and EC motors up to 72 W
EPOS2 24/5	For DC and EC motors up to 120 W
EPOS2 50/5	For DC and EC motors up to 250 W
EPOS2 70/10	For DC and EC motors up to 700 W

## MAXPOS Positioning Control Unit

The MAXPOS 50/5 is a motion controller for highly dynamic applications and receives motion and I/O commands from the higher-level EtherCAT master controlling the process.

MAXPOS Positioning Control Unit	Beschreibung
MAXPOS 50/5	For DC- and EC motors up to 250 W

More information: [www.maxonmotor.com](http://www.maxonmotor.com)





# When it really matters.

## **maxon motor – Precise drives ince 1961.**

More than 50 years of experience, nonstop innovation and superior product quality combine with outstanding customer service and sales offices in over 40 countries to make maxon motor a most reliable partner in drive technology. Your specific needs determine our way of doing business: individual, customized drive solutions are our greatest strength. The maxon motor range of products, manufactured by using our unique modular system, is comprehensive and encompasses:

- Brushless and brushed DC motors with ironless rotors and assigned outputs of up to 500 watts
- Brushless flat motors with iron cores and outputs of up to 100 watts
- Spur and planetary gearheads and customized special gears
- Feedback devices
- Servoamplifiers and positioning control units
- Innovative CIM and MIM components
- Customer-specific drives

**maxon motor**

driven by precision



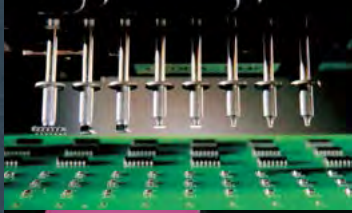

# maxon Markets

- Medical science
- Industrial automation
- Instrumentation and Inspection
- Communication
- Robotics
- Security
- Automotive
- Aerospace
- Consumer applications

# maxon drives set the world in motion.

Precision drives from maxon motor are used in a multitude of application fields. The most famous example comes is from astronautics. NASA's Mars rovers prove that maxon drives can perform their work with absolute reliability, even under the harshest conditions. Therefore, it should come as no surprise that high-precision drive systems from maxon motor are in wide use on Earth.

## Quality assurance.

### Quality with no compromise.

Consistent standards on quality, safety, and procedures ensure that only premium products leave our factories. The business and production processes fulfill international standards such as ISO 9001 and ISO 14001. maxon medical has ISO 13485 certification and products for the aerospace industry have ISO 9100 certification.

**maxon motor**

driven by precision







# A global network.

Everywhere in the world, maxon motor's sales engineers collaborate with customers to develop tailor-made drive solutions.

● **maxon Manufacturing Companies**

Switzerland (headquarters), Germany, Hungary, South Korea.

● **maxon Sales Companies**

Australia, Belgium/Luxembourg, China, Denmark, Germany, Finland, France, Great Britain, India, Italy, Japan, South Korea, the Netherlands, Norway, Austria/Hungary/Slovenia/Romania, Sweden, Switzerland, Spain, Taiwan, Czech Republic/Slovakia/Poland, USA.

○ **maxon Sales Agents**

Brazil, Hong Kong, Israel, Canada, Malaysia, Russia, Singapore, South Africa, Thailand, Turkey.

For detailed contact information please visit [contact.maxonmotor.com](https://www.maxonmotor.com)

**maxon motor**

driven by precision

# maxon motor at a glance.

maxon motor is the worldwide leading provider of high-precision drives and systems up to 500 W. We develop and manufacture brushed and brushless DC motors with a unique ironless core winding as well as motors with iron cores. maxon motor's modular system includes planetary, spur and special gearheads, as well as encoders and control electronics. High-tech CIM and MIM components are manufactured in a specialized facility. maxon motor stands for top quality, innovation, competitive pricing, and a worldwide distribution network. What matters most, however, is the high quality of the customer-specific solution that we create with you and for you.



[www.maxonmotor.com](http://www.maxonmotor.com)

201510

**maxon motor**  
driven by precision