

MACRON MINI 6 - 56 LINEAR ACTUATOR

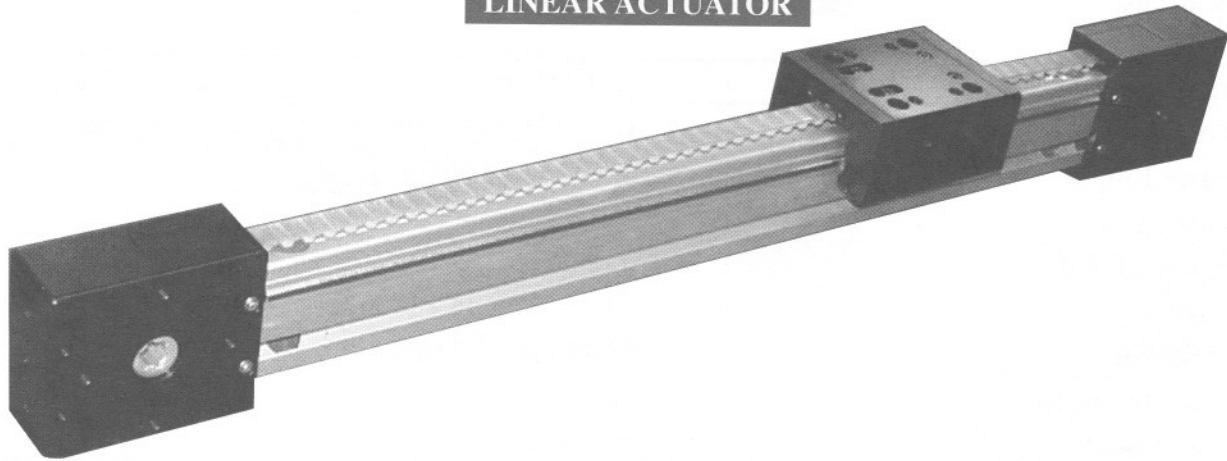

Features

- Macron actuators are furnished to your specifications
- Available in any length up to 12 meters (40 ft.)
- Fast turnaround on all standard units

Optional

- Sensors
- Wrap-Around Cart (WAC)
- Bellows

Motor Mounting (See Page 22)

- Motor Mount Adapter
- NEMA 23, 34 & 42 (standard)
- 48, 56 & non-NEMA sizes (optional)
- Spline Adapter
- Shafted Pulley

Sold & Serviced By:

 Toll Free Phone (877) SERV098
 Toll Free Fax (877) SERV099
 www.electromate.com
 sales@electromate.com

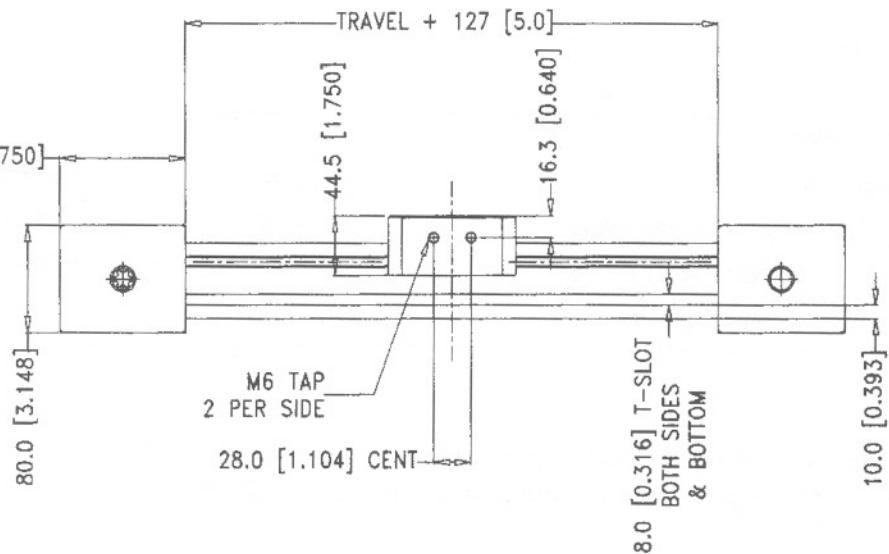
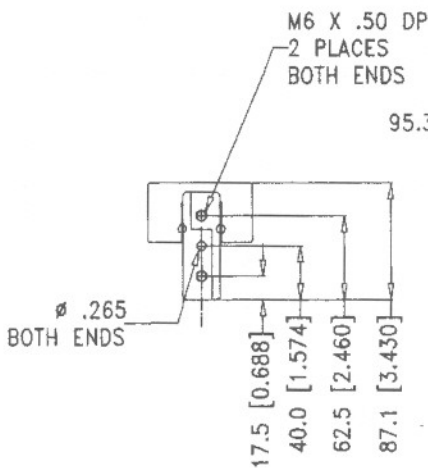
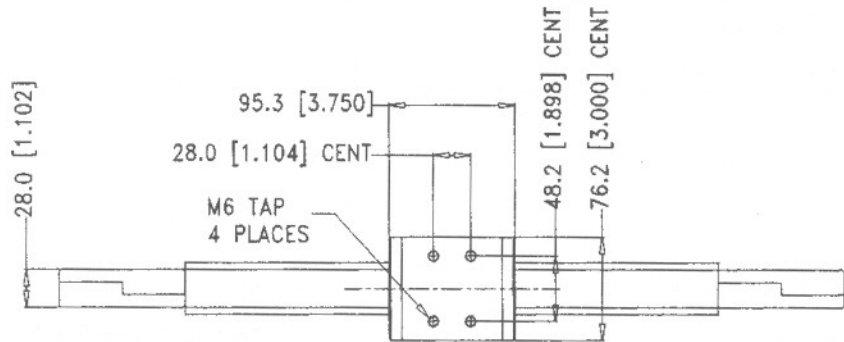

MACRON MINI 6 - 56
LINEAR ACTUATOR
TECHNICAL DATA

Specifications:

| | | |
|------------------------|--|--|
| Repeatability | | +/- 0.001 in |
| Linear Accuracy | | +/- 0.003 in per 36 in |
| Breakaway Torque | | 10 - 12 oz-in |
| Belt Tensile Limit | | 875 lbs |
| Belt Running Load | | 250 lbs |
| Travel/Revolution | | 200 mm/rev (7.874 in/rev) |
| Pulley Diameter | | 63.66 mm (2.506 in) |
| Pulley Weight (each) | | 6.5 oz |
| Maximum Speed | | 400 in/sec |
| Acceleration Exceeding | | 20 G's |
| Motor Mount/Coupling | | NEMA 23, 34 & 42 (standard), 48, 56 & non-NEMA sizes (optional) |

Shipping Weight

| | | | |
|--|-----------------------|--|--------|
| <small>Sold & Serviced By:</small>  <small>For Free Phone (877) SERV098</small> <small>Toll Free Fax (877) SERV099</small> <small>www.electromate.com</small> <small>sales@electromate.com</small> | First meter of travel | | 12 lbs |
| | Additional per meter | | 4 lbs |

Load Capacities

| | | |
|--------------------|--|----------------------------|
| Dynamic Horizontal | | To Customer Specifications |
| Static Horizontal | | To Customer Specifications |

Inertia Calculation

| ~ W values of actuators | weight | inertia |
|----------------------------------|-------------|-----------------------------|
| ~ weight of cart & hardware | 1.156 lbs | 1.812 lbs - in ² |
| ~ weight of belt/meter of travel | 0.625 lbs/m | 0.980 lbs - in ² |
| ~ weight of (two) pulleys | 0.812 lbs | 0.637 lbs - in ² |

For Multi-Axis Units and other specifications not listed, contact your local Distributor or Macron for Engineering Design assistance and quotations.