

MACRON RAIL LINEAR ACTUATOR

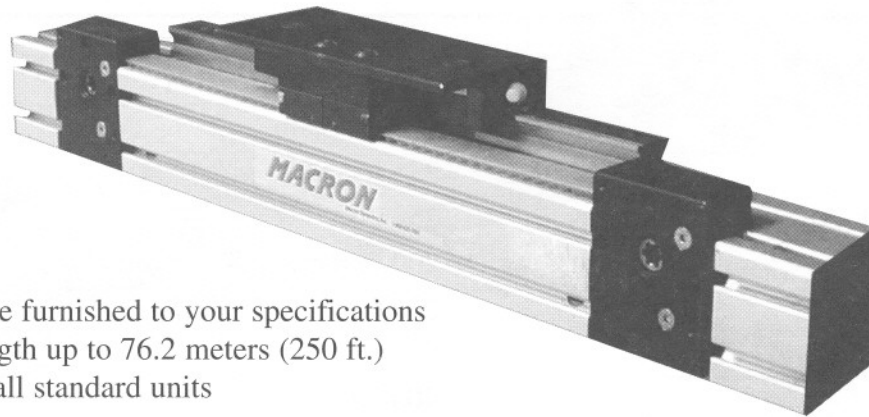

Features

- Macron actuators are furnished to your specifications
- Available in any length up to 76.2 meters (250 ft.)
- Fast turnaround on all standard units

Optional

- Sensors
- Dual Belt
- Bellows

Motor Mounting (See Page 22)

- Motor Mount Adapter
- NEMA 23, 34 & 42 (standard)
48, 56 & non-NEMA sizes (optional)
- Spline Adapter
- Shafted Pulley

Sold & Serviced By:
 **ELECTROMATE**
 Toll Free Phone (877) SERV098
 Toll Free Fax (877) SERV099
 www.electromate.com
 sales@electromate.com

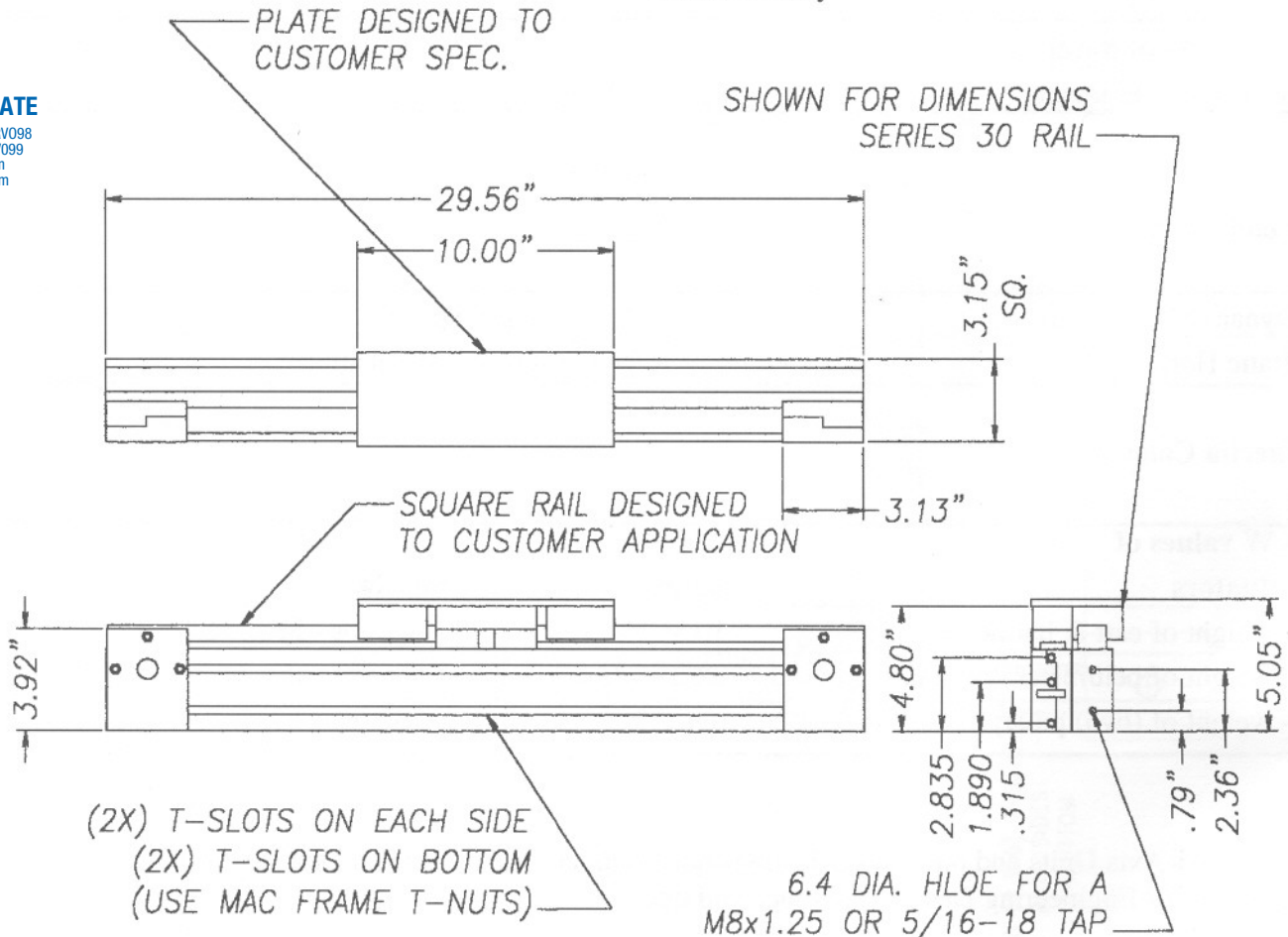

MACRON RAIL LINEAR ACTUATOR

TECHNICAL DATA

Specifications:

Repeatability		+/- 0.001 in
Linear Accuracy		+/- 0.003 in
Breakaway Torque		TDB* oz-in
Belt Tensile Limit		1750 lbs
Belt Running Load		0 - 500 lbs
Travel/Revolution		150 mm/rev (5.906 in/rev)
Pulley Diameter		47.75 mm (1.88 in)
Pulley Weight (each)		9.5 oz
Maximum Speed		TDB* in/sec
Acceleration Exceeding		TDB* G's
Motor Mount/Coupling		NEMA 23, 34 & 42 (standard), 48, 56 & non-NEMA sizes (optional)

Shipping Weight

First meter of travel		Application Specific
Additional per meter		Application Specific

Load Capacities

Dynamic Horizontal		To Customer Specifications
Static Horizontal		To Customer Specifications

Inertia Calculation

~ W values of actuators	weight	inertia
~ weight of cart & hardware	TDB* lbs	TDB* lbs - in ²
~ weight of belt/meter of travel	0.938 lbs	0.827 lbs - in ²
~ weight of (two) pulleys	1.188 lbs	0.524 lbs - in ²

*Application Specific

For Multi-Axis Units and other specifications not listed, contact your local Distributor or Macron for Engineering Design assistance and quotations.

Sold & Serviced By:

 Toll Free Phone (877) SERV098
 Toll Free Fax (877) SERV099
 www.electromate.com
 sales@electromate.com