

MACRON Dual Independent Belt Drive

(Mechanical Belt Drive to be used in conjunction with external guide Bearing System)

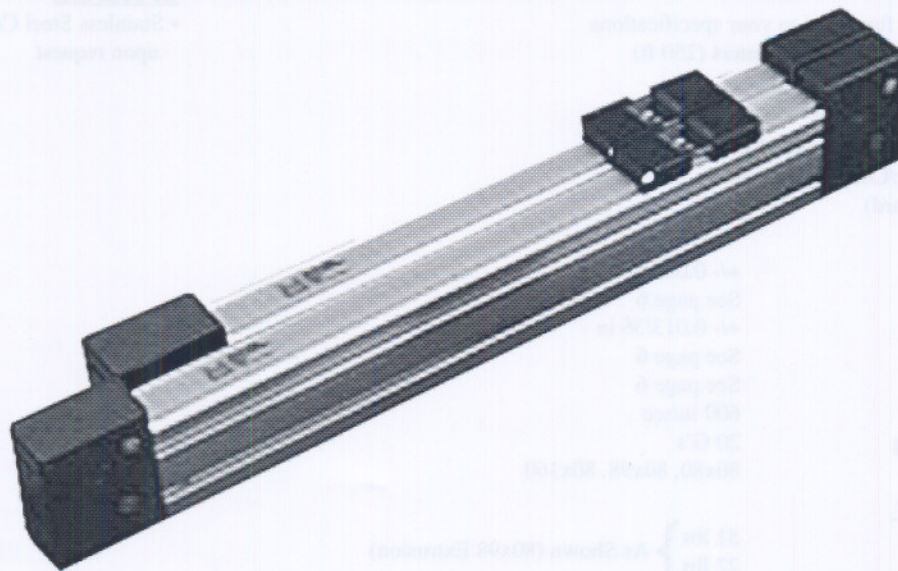

Sold & Serviced By:

ELECTROMATE

Toll Free Phone (877) SERV098

Toll Free Fax (877) SERV099

www.electromate.com

sales@electromate.com

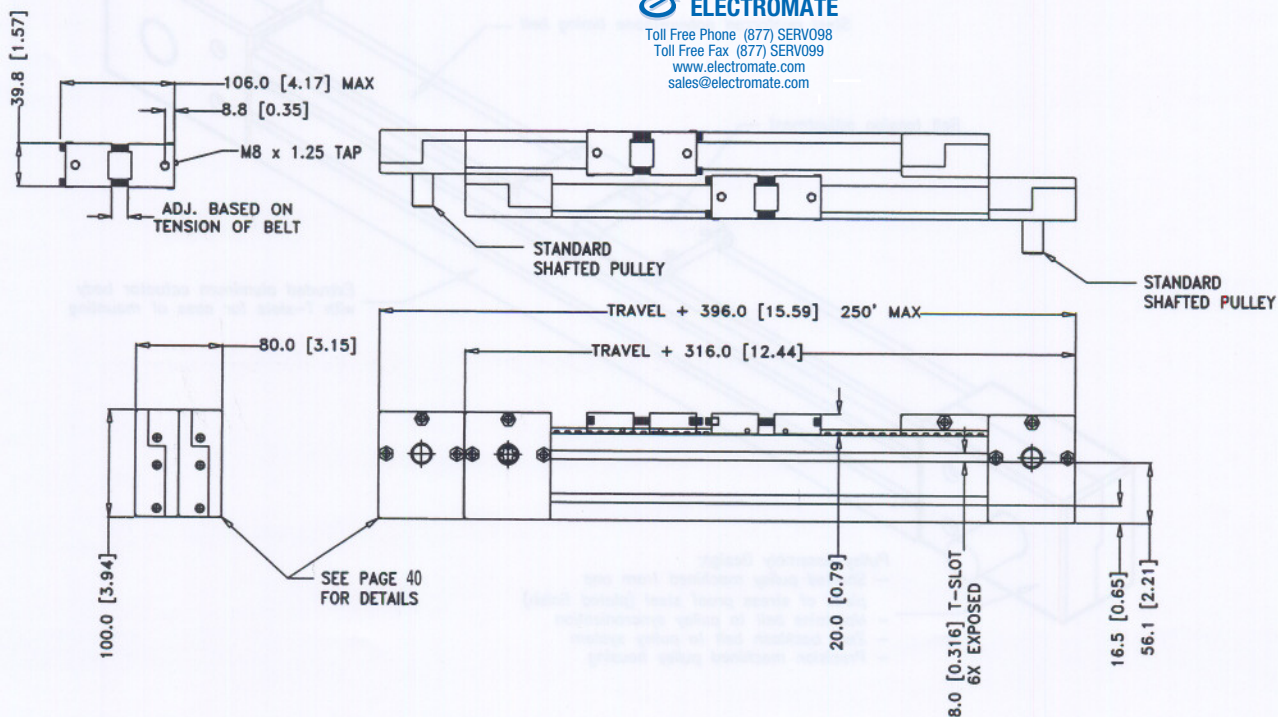

MACRON Dual Independent Belt Drive

FEATURES

- Macron Actuators are furnished to your specifications
- Available in any length up to 76.2 meters (250 ft)
- Fast turnaround on all standard units
- Corrosion resistant components

MOTOR MOUNTING (See Page 38)

- Motor Mount Adapter - NEMA 23, 34 & 42 - (standard) - Other sizes are optional
- Shafted Pulley (standard)

SPECIFICATIONS

Repeatability	+/- 0.001 in
Load Capacities	See page 6
Positional Accuracy	+/- 0.013/36 in
Belt Options 25S, 25H	See page 6
Pulley Information	See page 6
Maximum Speed	400 in/sec
Acceleration Exceeding	20 G's
Beam Options	80x80, 80x98, 80x160

SHIPPING WEIGHT

First meter of travel	29 lbs	} As Shown (80x80S Extrusion)
Additional per meter	11 lbs	

Note: No Flag Mount for Sensors

OPTIONAL

- Stainless Steel Components upon request

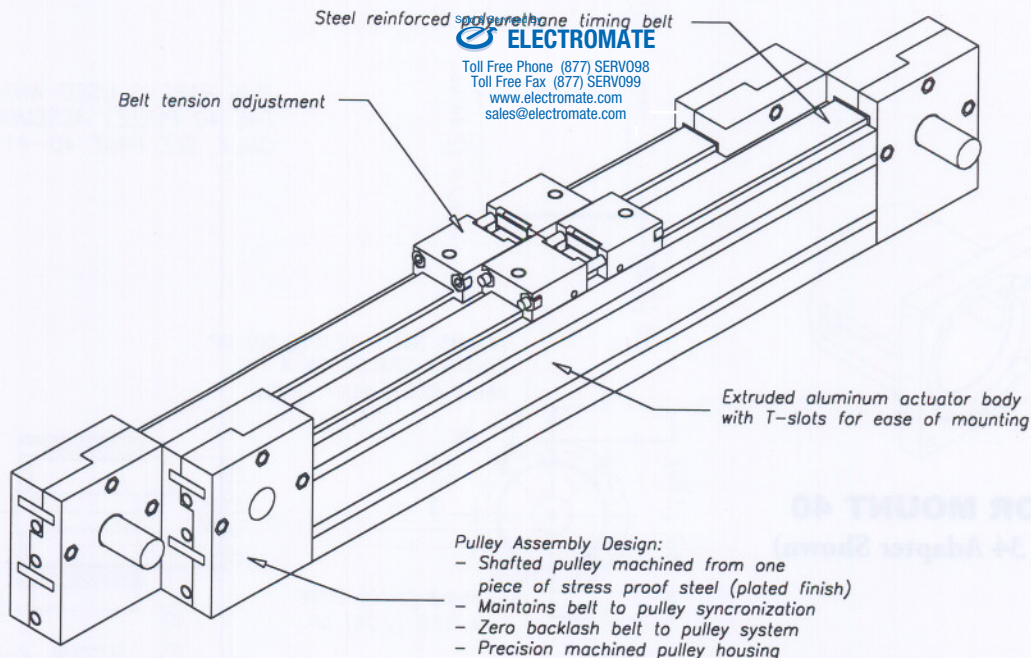

- For Multi-Axis Units and other specifications not listed, contact your local Distributor or Macron for Engineering Design assistance and quotations.