

# LINTECH<sup>®</sup>

## Round Rail Components

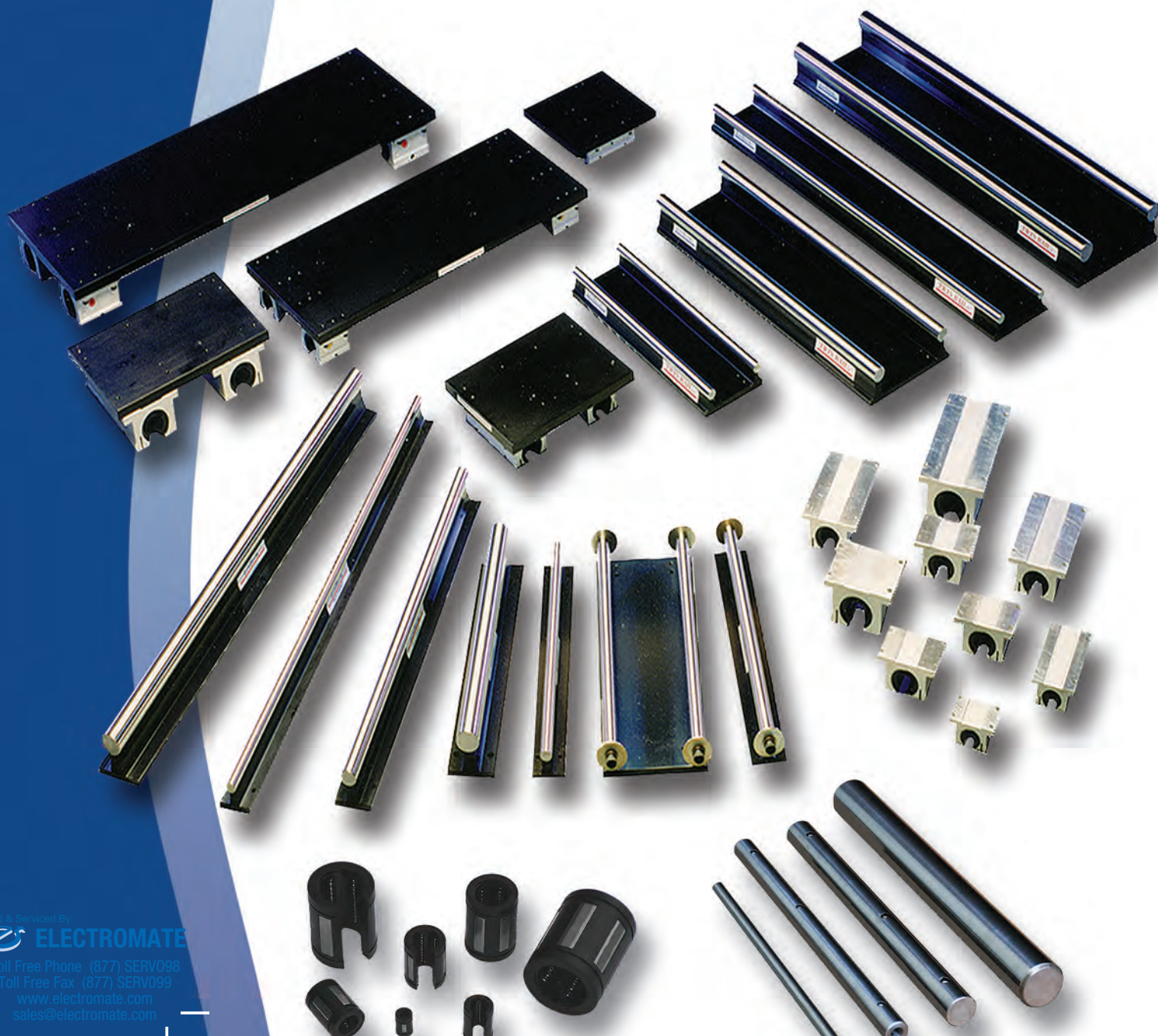

Sold & Serviced By  
**ELECTROMATE**

Toll Free Phone (877) SERV098  
Toll Free Fax (877) SERV099  
[www.electromate.com](http://www.electromate.com)  
[sales@electromate.com](mailto:sales@electromate.com)

# Table of Contents

---

|  | <b>Pages</b>             |
|--|--------------------------|
| <b>Design Considerations</b>                                   | <b>2 to 16</b>           |
| <b>Linear Bearings, Pillow Blocks and Carriage Assemblies</b>  | <b>17 to 36</b>          |
| <b>Precision Shafting, Shaft Supports and Shaft Assemblies</b> | <b>37 to 65</b>          |
| <b>Terms of Sale</b>   | <b>Inside Back Cover</b> |

Sold & Serviced By:



Toll Free Phone (877) SERV098

Toll Free Fax (877) SERV099

[www.electromate.com](http://www.electromate.com)

[sales@electromate.com](mailto:sales@electromate.com)

---

### Precision Shafting

LINTECH's precision "cut to length" 1060 carbon steel inch precision shafting is manufactured with the highest standards for surface finish, surface hardening, roundness and straightness. These manufacturing procedures provide a quality shaft with long life and optimum performance in today's demanding applications. Inch diameters are available from 0.25 to 2.0 inches in class L, S and N diameter tolerances. Metric diameters are available from 8 to 50 mm. Any length is available within .001 inch increments, up to the standard maximum stocked length.



### ES End Shaft Support Blocks

LINTECH's aluminum and steel end support housings (ES series) provide a simple means to fix the ends of a shaft to a mounting surface. The ES-S series is manufactured from 1045 steel, while the ES-A series is manufactured from 6061-T6 aluminum.

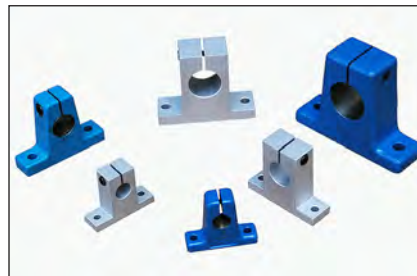

### ARS & LSRS Shaft Supports

LINTECH's aluminum and steel shaft supports provide a simple means to fix a shaft to a user mounting surface in an application that requires the shaft to be fully supported over its entire length. The ARS series is manufactured from 6061-T6 aluminum, while the low profile LSRS series is manufactured from C-1018 steel.



### SA Shaft Assemblies

LINTECH's single Shaft Assembly (SA series) is a complete assembly which simplifies the use of a linear bearing in a mechanical positioning application. Each assembly has a steel shaft mounted to a black anodized, precision machined, aluminum support. The pre-drilled base mounting holes in the 6, 12, 18, and 24 inch supports allow for easy customer mounting. The SA assemblies come in standard lengths from 6 to 192 inches, and with shaft diameters from 0.50 to 2.00 inches.

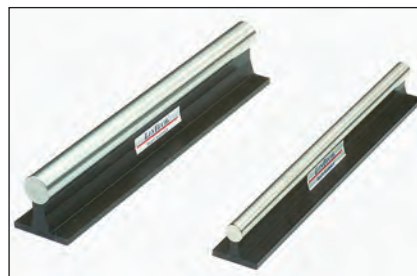

### TRSA Shaft Assemblies

LINTECH's TWIN RAIL® Shaft Assembly (TRSA series) is a complete assembly which simplifies the use of a linear bearing in a mechanical positioning application. Two steel shafts are mounted and aligned on the common base, therefore eliminating the alignment process required for two separate shafts. The pre-drilled base mounting holes in the support allow for easy customer mounting. Each 6, 12, 18, and 24 inch aluminum support has two threaded holes at one end to assist in leveling the assembly. The TRSA comes in standard lengths from 6 to 192 inches, and with shaft diameters from 0.50 to 2.00 inches.



### LBCA & LBOA Precision Linear Bearings

LINTECH's LBCA & LBOA offer an "all steel" linear bearing design. This provides for operation in high temperature environments (up to + 600° F) and can offer a smoother operation when compared to the LBC & LBO style bearings for some applications.



### LBC, LBO & Metric High Capacity Linear Bearings

LINTECH's high capacity linear bearings have a ball conforming outer race coupled with a self-aligning feature which allows for zero bearing clearance while maintaining smooth operation. The independently self-aligning outer bearing races insure smooth operation by allowing miss-alignment up to 1/2 degree in all directions. These linear bearings are available in "open" or "closed" styles. The closed style is available in 0.25 to 2.00 inch nominal diameters, while the open style is available in 0.50 to 2.00 inch nominal diameters. Metric style diameters are available from 16 mm to 50 mm.



### SLBO, SLBC, DLBC & DLBO Pillow Blocks

LINTECH's SLBC and SLBO series have one linear bearing and two wiper seals per pillow block, and are self-aligning in all directions. The SLBO and DLBO series have a screw for pre-load adjustment to reduce the shaft and bearing clearance. LINTECH's DLBC and DLBO series have two linear bearings in one aluminum pillow block, separated by a wick that serves as an oil reservoir. Each pillow block housing provides a flat top surface for load mounting and alignment.

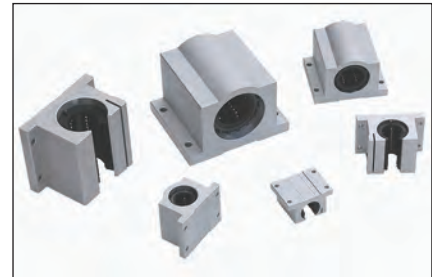

### TRCA Carriage Assemblies

LINTECH's TRCA series, TWIN RAIL® carriage assemblies are pre-engineered assemblies which have either SLBO or DLBO pillow blocks mounted to a 6061-T6 aluminum, black anodized machined plate. The pillow blocks are pre-aligned and doweled to the carriage plate to match LINTECH's TRSA series shaft assemblies. The use of a TRCA carriage assembly and a TRSA shaft assembly reduces the process of mounting and aligning two shafts and pillow blocks. Each carriage surface is machined which allows for accurate mounting of customer loads, and are available with mounting holes with stainless steel inserts. Carriage assemblies are provided with pillow blocks for shaft diameters from 0.50 to 2.00 inches, and come in lengths from 6 to 30 inches.

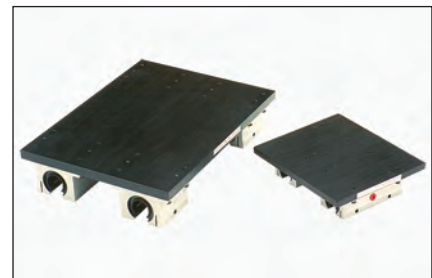

### Options

LINTECH can provide many options which allow the user to customize a product for their application requirements. These include: metric shaft assemblies, tubular shafting, bearing locks, metric linear bearings, special finishes, custom TWIN RAIL® assembly widths and lengths, etc.. Contact the factory if a desired option is not shown in this catalog.

## Precision Steel Shafts

**LINTECH's** precision shafting, SA and TRSA shaft assemblies use Rockwell 60-65C hardened and ground shafts. These high quality carbon steel shafts are accurately machined and heat treated for uniform hardness. They are also inspected for straightness, roundness, and smoothness. The high hardness and extremely smooth surface of the steel shafts creates an abrasion-resistant surface, which reduces material wear and system friction, while maintaining an optimal surface finish. Inch and Metric shaft diameters are available in different shaft tolerances.

## Stainless Steel Shafts

For corrosion resistant applications, **LINTECH** provides 440C stainless steel shafts with the same shaft diameter tolerance, hardness depth, and straightness as our standard steel shafts. Stainless steel shafts are typically used in the chemical and food processing industries, for medical equipment in corrosive environments, or in strong oxidizing atmospheres where no lubricating oil is available.

## Chrome Plated Shafts

**LINTECH** can also provide chrome plated precision shafting for those demanding applications that required a high level of corrosion resistance.

## Shaft Diameter Tolerance

**LINTECH** shafts are precision ground to a very close diameter tolerance. This diameter tolerance is an extremely important factor when using **LINTECH** linear bearings. It assures a dependable fit, with proper clearance between a shaft and linear bearing.

## Shaft Hardness

The hardness of a steel shaft is its ability to prevent nicks, indentations, or grooving. It is an important factor in determining the life of a linear bearing system in an application. The heat treatment process performed on all shafts assures uniform hardness in radial and axial directions.

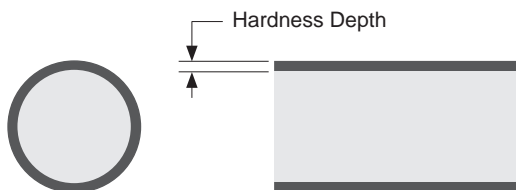

## Shaft Straightness

The exceptional straightness of all shafts eliminate system binding when using a TRSA shaft assembly with a TRCA carriage assembly, and helps the alignment process when using two precision shafts, or SA shaft assemblies, in a parallel assembly application.

## Shaft Supports

**LINTECH** ES end supports use 6061-T6 aluminum (-A), or 1045 steel (-S). These supports slide over the hardened shaft, and have a screw that is adjusted to clamp the support onto the shaft. The ARS series assembly support is manufactured from aluminum, while the low profile LSRS series is manufactured from C-1018 steel and functions the same as the ARS series, but has a smaller overall height.

### ES-A Series

### ES-S Series

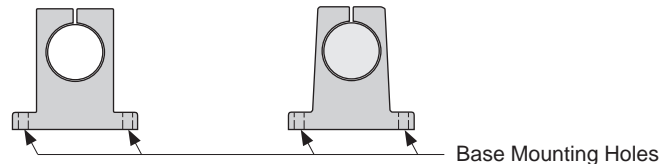

### ARS Series

### LSRS Series

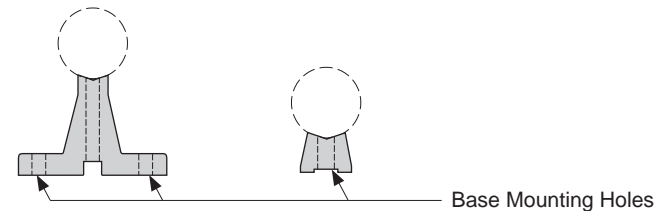

## Shaft Assemblies

**LINTECH** shaft assemblies (SA and TRSA series) use 6061-T6 precision machined aluminum supports. These black anodized supports have pre-drilled base mounting holes that come in both single supports for the SA, and **TWIN RAIL®** supports for the TRSA. These precision machined supports come in 6, 12, 18, and 24 inch lengths, and can be combined for nearly unlimited assembly lengths.

### SA Series - single rail supported assembly

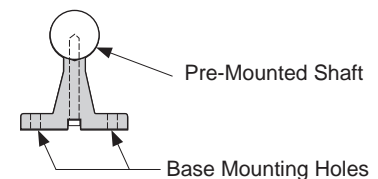

### TRSA Series - **TWIN RAIL®** supported assembly

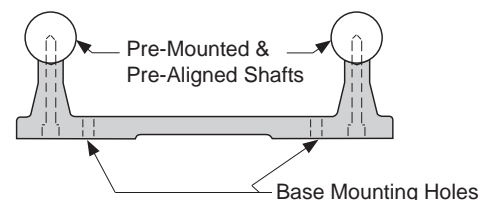

## Precision Steel Linear Bearings

**LINTECH's** LBCA and LBCO precision steel linear bearings are manufactured with high quality steel that is hardened and precision ground. The recirculating precision ground bearing balls roll freely into and out of the load zone. The balls are guided through their recirculation path by a steel retainer and hardened sleeve. These bearings are used in high temperature applications and where self alignment is not required.

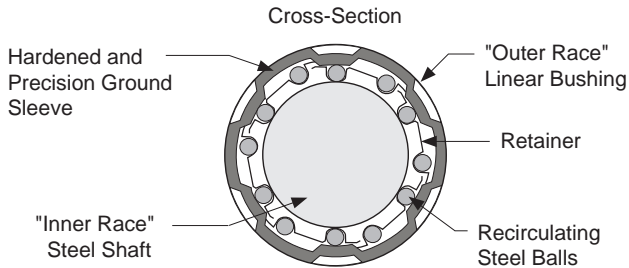

## Pillow Blocks

**LINTECH's** SLBC, SLBO, DLBC and DLBO series pillow blocks use one or two, LBC or LBO, linear bearings with integral seals to obtain their long life, and high load capacity. The precision machined 6061-T6 aluminum pillow block mounting surface allows for accurate and easy mounting to a common carriage plate. The SLBO and DLBO pillow block models have an adjusting screw to permit adjustment of radial play between the "inner race" steel shaft and the "outer race" linear bearing. A retention pin is used to secure the linear bushing within the aluminum housing.

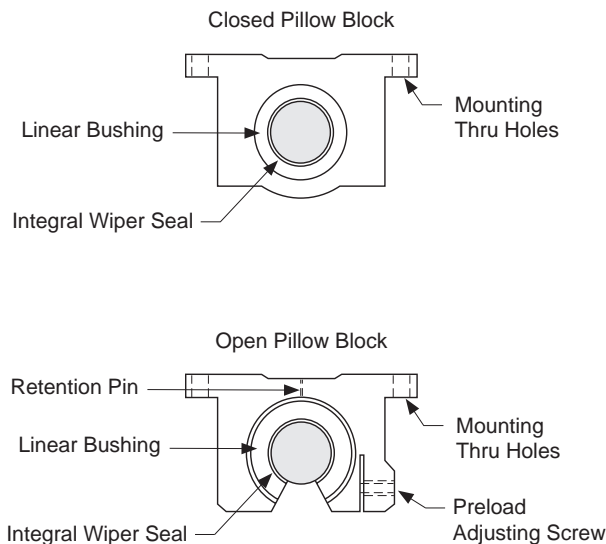

## Self-Aligning Linear Bearings

**LINTECH's** LBC, LBC and Metric style linear bearings consists of a wear resistant, low friction, smooth, resilient, plastic ball retainer and plastic outer sleeve. The load carrying components of the linear bearing are precision machined, hardened steel bearing plates, and recirculating steel balls. There are longitudinal grooves along the inner surface of the steel bearing plates which contact the recirculating steel balls. The steel bearing plate is also designed slightly thicker in the middle than at either end. This tapered thickness along the bearing plate length allows the bearing plate to automatically align itself with the "inner race" steel shaft. This assures smooth entry and exit of the recirculating steel balls in and out of the load area, along with a more uniform load distribution within the linear bearing.

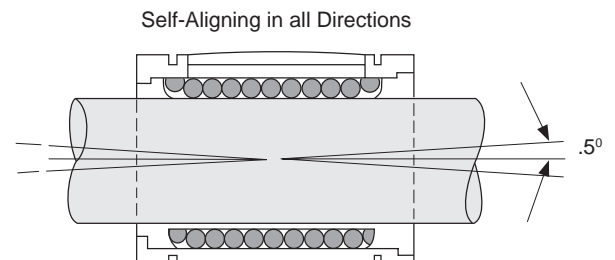
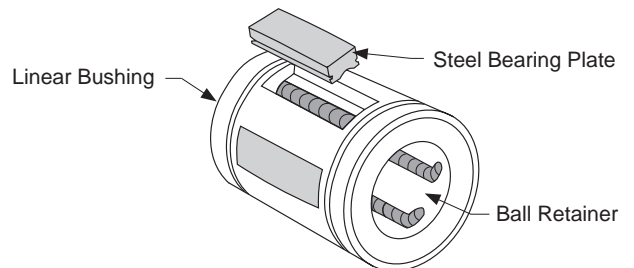
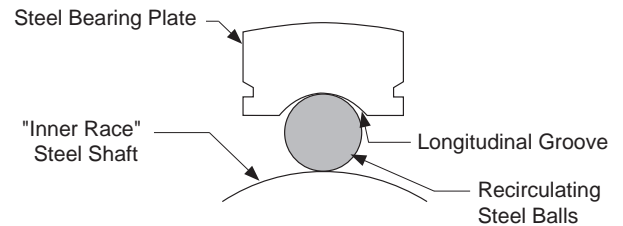
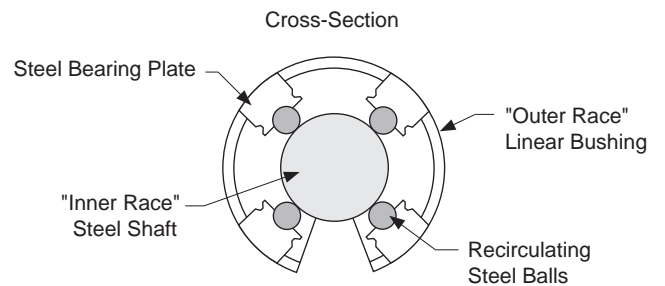

## Travel Life

The rated life of a linear bearing, pillow block or carriage assembly is measured in inches (or km) of travel under a specified load. The failure of a linear bearing system occurs when the operating stresses from the rolling balls in the linear bushing cause material fatigue, resulting in flaking of the steel balls or steel shaft and/or grooving in the steel shaft.

Every linear bearing, pillow block or carriage assembly has a dynamic load rating associated with it based on a  $L_{10}$  life of 2 million inches of travel (approximately 50 km). For most applications, knowing the load applied to a linear bearing and the life required is all that is needed in selecting the proper components for the task at hand.

For more demanding applications the hardness of the shaft used, operating temperature, direction of the load, additional shock loads, and linear speed of the bearing are all factors that should be considered. This allows for an accurate prediction of the dynamic life of a linear bearing, pillow block or carriage assembly in a specific application.

## Load Ratings

The applied load that a linear bearing, pillow block or carriage assembly will see needs to be compared against the load capacity of that component. The dynamic load rating of a linear bearing, pillow block or carriage assembly pertains to the component in motion and this load rating is based on the number of inches (or km) traveled.

## Required Life

It is important to evaluate the required or expected life from a linear bearing system for a given application load. This required life is specified by the user as the desired life prior to a possible failure. This period of time (usually in years) then will need to be converted into a travel distance (typically inches or km) to select the appropriate size linear bearing, pillow block or carriage assembly.

## Required Life Examples

Below are two examples which illustrate the importance of a dynamic load rating based upon travel life. These two applications could lead to the selection of different components due to the difference in the number of required inches of travel, even though the the applied load is the same 150 lbs (68 kg).

### Example 1:

assembly needs to last 6 years  
with  
a 10 inch move out, then back 10 inches every 90 seconds  
for  
8 hours per day  
for  
5 days per week  
and  
50 weeks per year

$$\frac{(10 \times 2) \text{ inches}}{90 \text{ sec}} \times \frac{60 \text{ sec}}{1 \text{ min}} \times \frac{60 \text{ min}}{1 \text{ hr}} \times \frac{8 \text{ hr}}{1 \text{ day}} \times \frac{5 \text{ days}}{1 \text{ week}} \times \frac{50 \text{ weeks}}{1 \text{ yr}} \times 6 \text{ years} = \mathbf{9,590,400} \text{ inches of travel}$$

### Example 2:

assembly needs to last 8 years  
with  
(24) 1 inch moves out, then back 24 inches every 30 seconds  
for  
12 hours per day  
for  
7 days per week  
and  
52 weeks per year

$$\frac{(24 \times 2) \text{ inches}}{30 \text{ sec}} \times \frac{60 \text{ sec}}{1 \text{ min}} \times \frac{60 \text{ min}}{1 \text{ hr}} \times \frac{12 \text{ hr}}{1 \text{ day}} \times \frac{7 \text{ days}}{1 \text{ week}} \times \frac{52 \text{ weeks}}{1 \text{ yr}} \times 8 \text{ years} = \mathbf{201,277,440} \text{ inches of travel}$$

## Safety Factors

As a practice, safety factors should always be used when selecting a linear bearing, pillow block or carriage assembly for a given application. For most real world applications people do use safety factors. However, sometimes the incorrect safety factor or no safety has been used. This can lead into an unexpected system failure. **LINTECH** provides, in a chart form, different safety factor recommendations for linear bearings, pillow blocks or carriage assemblies. Keep in mind that these recommendations for safety factors are not hard and fast rules. Safety factors for a specific linear bearing system may have to be increased or decreased based upon the application requirements.

## Linear Bearing Load Capacities

Linear Bearing Load Capacities are usually specified with a dynamic value. These values are used to help select the proper linear bearing, pillow block or carriage assembly size for a given load/life application. The use of adequate safety factors is a key element in the selection process of a linear bearing system for a given application. Selecting a bearing system with no safety margin can lead to problems relating to performance and long term life.

## Dynamic Load Capacity

Dynamic Loads exert a force upon the linear bearing, pillow block or carriage assembly while in motion. Every linear bearing system has a load capacity associated with it that is based upon the number of inches (or km) traveled. If the load applied to the linear bearing system is less than the rated value at 2 million inches (or 50 km) of travel, the linear bearings will have a longer life associated with them that is exponential. Therefore, to properly select a linear bearing, pillow block or carriage assembly that will last the required travel life for an application, the forces acting upon the linear bearings need to be reviewed. Once the force on the heaviest loaded bearing has been determined and a proper safety factor selected, then the life of that bearing, pillow block or carriage assembly can be determined by using a simple mathematical equation.

Even though the forces acting upon a bearing, pillow block or carriage assembly can be calculated, other parameters such as changing loads, speeds, acceleration rates, environments, and lack of lubrication produce extra forces (stresses) that are hard to quantify. As a bearing moves, there are additional resultant loads as a by-product. The rate at which the bearing begins to move a load can have a large impact on its life. The linear bearings see this start/stop rate as a shock load each time. These and other variable loads cannot be calculated precisely. Thus, a safety factor should be applied to account for these loads which could fatigue the system and cause premature failure. See the below chart as a guideline.

### Recommended Linear Bearing Dynamic Safety Factors

| Impacts or Vibration | Speed (in/sec) | Acceleration (G's) | Min. Safety Factor - S |
|----------------------|----------------|--------------------|------------------------|
| None                 | < 5            | < 0.25             | 1.0 - 2.0              |
| Small                | 5 - 10         | 0.25 - 0.50        | 2.0 - 3.0              |
| Medium               | 10 - 20        | 0.50 - 1.00        | 3.0 - 4.0              |
| Large                | 20 - 50        | 1.00 - 1.50        | 4.0 - 6.0              |
| Very Large           | > 50           | > 1.50             | 6.0 - 8.0              |

## Safety Factor Example

*The application calls for moving a part (weight = 150 lbs) that is mounted to a carriage assembly. The carriage assembly will be moved to various positions at a speed of 9 IPS, with an acceleration of 0.75 G's.*

From above chart - use a 3.5 safety factor

Load      Safety Factor      *Select a carriage assembly that has a dynamic capacity greater than this value*

$$150 \times 3.5 = 525 \text{ lbs}$$



## Hardness factor - $F_H$

The maximum travel life of a linear bearing is achieved when the shaft surface has a hardness value greater than (>) Rockwell 60C. This hardness assures that no shaft grooving or flaking will occur under normal operating conditions.

| <i>LINTECH</i><br>SL, SS, SN, SM, SA & TRSA | Rockwell<br>Hardness | $F_H$<br>factor |
|---|----------------------|-----------------|
| standard 1060 steel shafts                  | 60-65C               | 1.00            |
| 440C stainless steel shafts                 | 50-55C               | .52             |
| chrome plated 1060 steel shafts             | 67-72C               | 1.00            |

When using *LINTECH* bearings, pillow blocks or TRCA carriage assemblies with different shafting and hardness ratings, refer to the Shaft Hardness graph below for the correction factor.

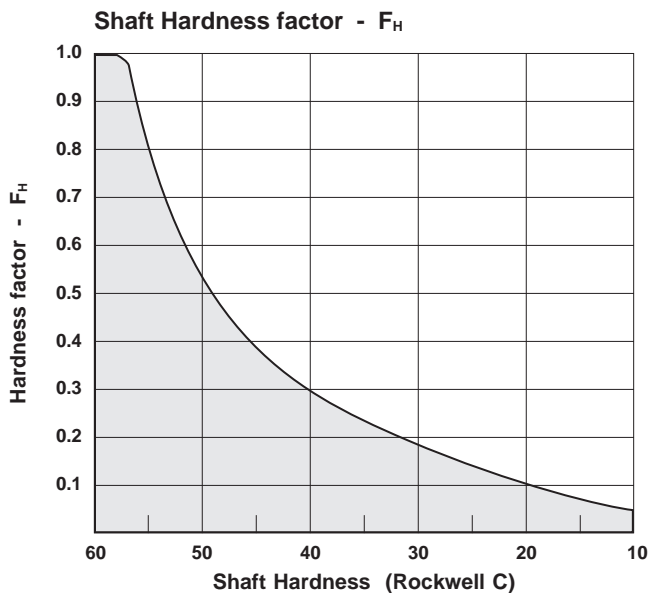

## Temperature factor - $F_T$

Ambient temperatures over 212° F (100° C) will fatigue any linear bearing system, and will cause a decrease in travel life. Please note that some *LINTECH* linear bearings, pillow blocks and carriage assemblies have a maximum operating ambient temperature of 185° F. Therefore these bearings, pillow blocks or carriage assemblies, should never be used in ambient temperatures above 185° F.

Refer to the temperature graph below for the correction factor when using a linear bearing system in an ambient temperature that exceeds 212° F (100° C).

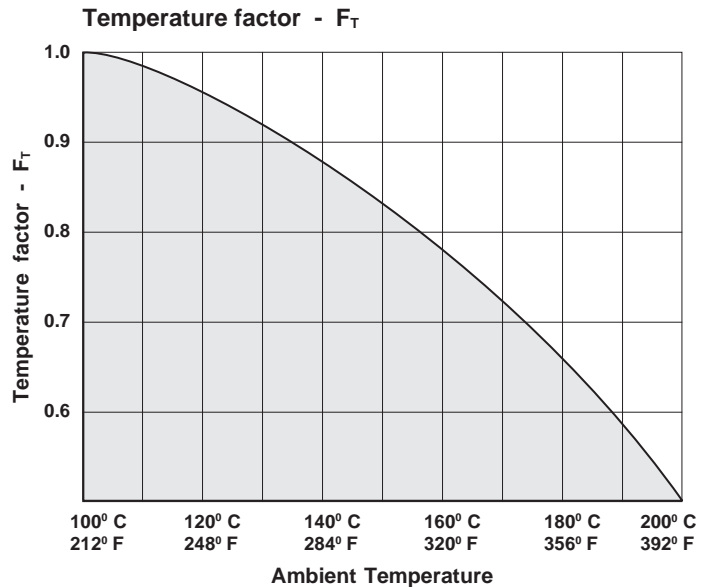

## Load direction factor - $F_L$

The maximum travel life of a linear bearing, pillow block or carriage assembly may need to be de-rated depending upon the direction the load is applied to the bearing. The Polar charts shown below for each bearing type indicate the de-rating factor (or multiplier) based upon the direction the load is applied to the bearing. In most applications not all the bearings will see the same applied load, so you can use the adjacent equation to determine the estimated life based upon the heaviest loaded bearing or the bearing which requires the greatest de-rating factor. This will yield a system life value showing the bearing which has the lowest overall travel life. To use the below graphs, simply find the intersecting point based upon the direction of the load (that the bearing sees) and then use the de-rating factor (i.e. 0.9, etc.), if any.

$$L = \left[ F_H \times F_T \times F_L \times \frac{R}{F \times S} \right]^3 \times B$$

- $L$  = normal travel life millions of inches (or Km)
- $R$  = rated dynamic load capacity of linear bearing, or carriage at 2 million inches of travel (or 50 Km)
- $F$  = user applied load
- $B$  = either 2 millions of inches (or 50 Km)
- $F_H$  = shaft hardness factor
- $F_T$  = environment temperature factor
- $F_L$  = load direction factor
- $S$  = dynamic safety factor

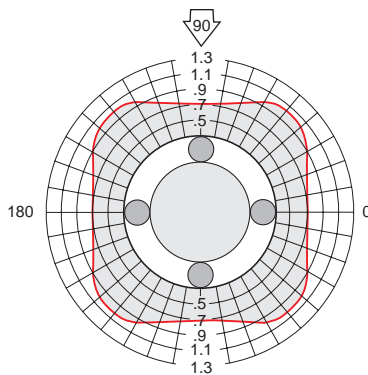

**LBC-4**  
**LBC-6, LBCA-6**  
**LBC-8, LBCA-8, SLBC-8, DLBC-8**  
**LBCA-10**

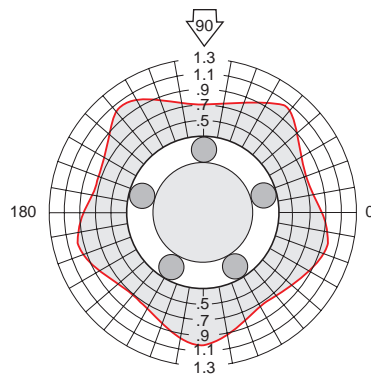

**LBC-10, SLBC-10, DLBC-10**  
**LBCA-12, LBCA-16**  
**LBCM-16, LBCME-16**

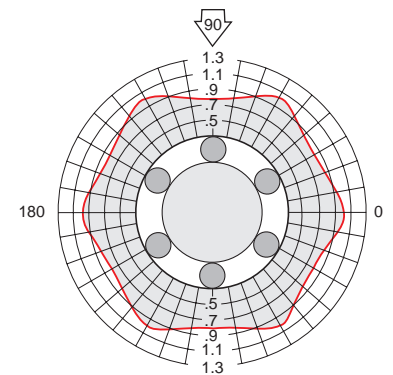

**LBC-12, SLBC-12, DLBC-12**  
**LBC-16, SLBC-16, DLBC-16**  
**LBC-20, LBCA-20, SLBC-20, DLBC-20**  
**LBC-24, LBCA-24, SLBC-24, DLBC-24**  
**LBC-32, LBCA-32, SLBC-32**  
**LBCM-20, LBCM-25, LBCM-30, LBCM-40**  
**LBCME-20, LBCME-25, LBCM-30**  
**LBCME-40, LBCME-50**

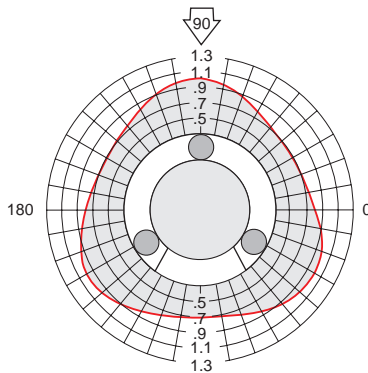

**LBCA-4**  
**LBO-8, LBOA-8,**  
**SLBO-8, DLBO-8**  
**LBOA-10**

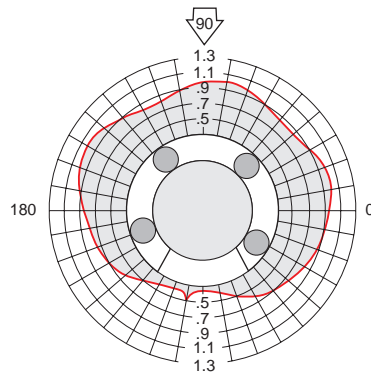

**LBO-10, SLBO-10, DLBO-10**  
**LBOA-12, LBOA-16**  
**LBOM-16, LBOME-16**

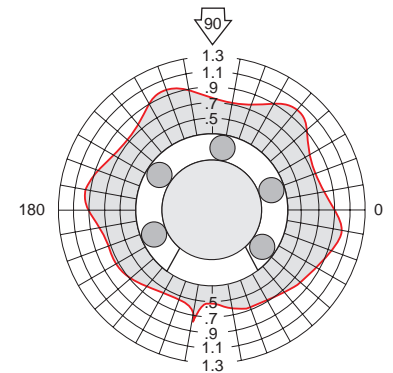

**LBO-12, SLBO-12, DLBO-12**  
**LBO-16, SLBO-16, DLBO-16**  
**LBO-20, LBOA-20, SLBO-20, DLBO-20**  
**LBO-24, LBOA-24, SLBO-24, DLBO-24**  
**LBO-32, LBOA-32, SLBO-32**  
**LBOM-20, LBOM-25, LBOM-30, LBOM-40**  
**LBOME-20, LBOME-25, LBOM-30**  
**LBOME-40, LBOME-50**

## Lubrication

**LINTECH** shafts, shaft assemblies, linear bearings, pillow blocks or carriage assemblies require a small amount of grease or oil for proper, long term operation. Lubrication will decrease system wear and the potential for rusting of shafts and linear bearing surfaces. For most applications a medium to heavy oil, light grease, or silicone based lubricant is recommended. The many built-in pockets within the linear bearing allows the adhesive properties of these lubricants to be stored for extended periods of time while minimizing sealing problems.

To obtain the estimated travel life for a given application, the linear bearings, pillow blocks or carriage assemblies should not run dry for an extended period of time. This lubrication schedule will ultimately need to be determined empirically during operation at the installation site since it can vary depending upon the environment, operation conditions, quantity and type of lube used, and other unforeseen conditions.

All **LINTECH** shafts, shaft assemblies, linear bearings, pillow blocks and carriage assemblies are shipped lightly coated with a rust preventative oil in the bearings or on the shafts. This will help prevent corrosion during the shipping period of the product. It is highly recommended that all shafts, shaft assemblies, linear bearings, pillow blocks and carriage assemblies be lubricated during installation or prior to operation. Also, periodic re-lubrication of the linear bearings and shafts, will help assure that the rated life of the system is obtained.

NOTE: Use of WD-40 or other cleaning solvents should strictly be avoided as they can cause damage to the linear bearing and shaft.

## Frictional Resistance

The total friction resistance of a **LINTECH** linear bearing, pillow block or carriage assembly can be calculated by using the following equation.

$$R = [ W \times \mu ] + F_s$$

**R** = Frictional resistance (lbs)

**W** = Load weight (lbs)

**μ** = coefficient of friction

**F<sub>s</sub>** = Frictional resistance - seal drag (lbs)

**Note:** **LINTECH** recommends using **μ** = .01 for all linear bearing systems.

The coefficient of friction (**μ**) of a **LINTECH** linear bearing, pillow block or carriage assembly consists of the rolling friction and the static (breakaway) friction. Two main factors affect the coefficient value. The type of lubrication used (i.e. oil, grease, or none) and the ratio between the total load weight and the dynamic load rating of the linear bearing, pillow block or carriage assembly used.

For most applications, **LINTECH** recommends using a value of .01 for the coefficient of friction. This value can be used for all linear bearings systems. The .01 value provides for an adequate safety margin when evaluating system performance. Other frictional resistances of a **LINTECH** linear bearing are seal drag and system preload. While wiper seals are used to retain lubricants and prevent entry of foreign particles into the linear bearing, they will increase the frictional resistance of the system. Increasing the preload of a linear bearing will also add extra frictional resistance. The chart below lists the nominal values for frictional seal drag of **LINTECH** linear bearings, pillow blocks and carriage assemblies.

### Frictional Resistance - F<sub>s</sub> (seal drag)

| Bearing size<br>-S (Sealed Versions)<br>and Pillow Blocks | F <sub>s</sub><br>(lbs) | Carriage Model<br>TRCA series | F <sub>s</sub><br>(lbs) |
|---|-------------------------|-------------------------------|-------------------------|
| Single, 0.50" diameter                                    | 0.5                     | <b>TRCA-8-xx</b>              | 2.0                     |
| Single, 0.62" diameter                                    | 0.4                     | <b>TRCA-10-xx</b>             | 1.6                     |
| Single, 0.75" diameter                                    | 0.4                     | <b>TRCA-12-xx</b>             | 1.6                     |
| Single, 1.00" diameter                                    | 0.4                     | - <b>TRCA-16-xx</b>           | 1.6                     |
| Single, 1.25" diameter                                    | 5.0                     | <b>TRCA-20-xx</b>             | 20.0                    |
| Single, 1.50" diameter                                    | 7.0                     | <b>TRCA-24-xx</b>             | 28.0                    |
| Single, 2.00" diameter                                    | 8.0                     | <b>TRCA-32-xx</b>             | 32.0                    |
| Double, 0.50" diameter                                    | 0.5                     | <b>TRCA-8-6</b>               | 1.0                     |
| Double, 0.62" diameter                                    | 0.4                     | <b>TRCA-10-6</b>              | 0.8                     |
| Double, 0.75" diameter                                    | 0.4                     | <b>TRCA-12-6</b>              | 0.8                     |
| Double, 1.00" diameter                                    | 0.4                     | <b>TRCA-16-6</b>              | 0.8                     |
| Double, 1.25" diameter                                    | 5.0                     | <b>TRCA-20-8</b>              | 10.0                    |
| Double, 1.50" diameter                                    | 7.0                     | <b>TRCA-24-12</b>             | 14.0                    |

All individual bearing force equations below pertain to a four bearing carriage which is at constant uniform velocity or with the carriage at rest. During acceleration and deceleration intervals of a positioning system, the force exerted upon an individual bearing changes as the acceleration or deceleration rate varies. In most cases, the extra force acting upon an individual bearing during the acceleration interval is offset by a reduced force during the deceleration interval. Therefore, using just the constant uniform velocity equations will adequately determine the life of an individual bearing for a particular application.

- $d_1$  - distance between center lines of shafts or rails (in)
- $d_2$  - distance between center lines of linear bearing blocks (in)
- $d_3$  - distance between carriage center and load center of gravity (in)
- $d_4$  - distance between carriage center and load center of gravity (in)
- $d_r$  - distance between carriage surface and linear bearings (in)
- $F_{BX}$  - force acting upon bearing in X-axis direction (lbs)
- $F_{BY}$  - force acting upon bearing in Y-axis direction (lbs)
- $F_{BZ}$  - force acting upon bearing in Z-axis direction (lbs)
- $W$  - load weight (lbs)

### Horizontal Applications

Example #1

Example #2

$$F_{1z} = \frac{W}{4} + \left[ \frac{W}{2} \times \frac{d_4}{d_2} \right] + \left[ \frac{W}{2} \times \frac{d_3}{d_1} \right]$$

$$F_{2z} = \frac{W}{4} - \left[ \frac{W}{2} \times \frac{d_4}{d_2} \right] + \left[ \frac{W}{2} \times \frac{d_3}{d_1} \right]$$

$$F_{3z} = \frac{W}{4} + \left[ \frac{W}{2} \times \frac{d_4}{d_2} \right] - \left[ \frac{W}{2} \times \frac{d_3}{d_1} \right]$$

$$F_{4z} = \frac{W}{4} - \left[ \frac{W}{2} \times \frac{d_4}{d_2} \right] - \left[ \frac{W}{2} \times \frac{d_3}{d_1} \right]$$

### Side Mounted Applications

$$F_{1z} = F_{3z} = \frac{W}{4} + \left[ \frac{W}{2} \times \frac{d_4}{d_2} \right]$$

$$F_{2z} = F_{4z} = \frac{W}{4} - \left[ \frac{W}{2} \times \frac{d_4}{d_2} \right]$$

$$F_{1y} \sim F_{3y} = \left[ \frac{W}{2} \times \frac{d_3 + d_r}{d_1} \right]$$

### Vertical Applications

$$F_{1x} \sim F_{3x} = \frac{W}{2} \times \frac{d_4 + d_r}{d_2}$$

$$F_{1y} \sim F_{3y} = \frac{W}{2} \times \frac{d_3}{d_2}$$

$$F_{1x} + F_{3x} \sim F_{2x} + F_{4x}$$

$$F_{1y} + F_{3y} \sim F_{2y} + F_{4y}$$

### Mean Bearing Load Calculation

When the force acting upon an individual bearing varies, as is the case with the bottom axis bearings of a multi-axes positioning system, a mean bearing load calculation determines the life of that bearing.

$$F_{avg} = \frac{1}{3} ( F_{min} + 2 \times F_{max} )$$

- $F_{avg}$  - average force acting upon bearing (lbs)
- $F_{min}$  - minimum force acting upon bearing (lbs)
- $F_{max}$  - maximum force acting upon bearing (lbs)

## TRCA Rated Load Capacity

The **LINTECH** TRCA series, **TWIN RAIL**® carriage assembly consists of (2) DLBO or (4) SLBO series pillow blocks mounted to a precision machined aluminum plate. The pillow blocks are mounted, aligned, and then doweled in-place. They are designed to mate directly with the **LINTECH** TRSA series, **TWIN RAIL**® shaft assemblies. Using these two series in combination with each other will eliminate the requirement to align and set-up a mechanical positioning system to be parallel.

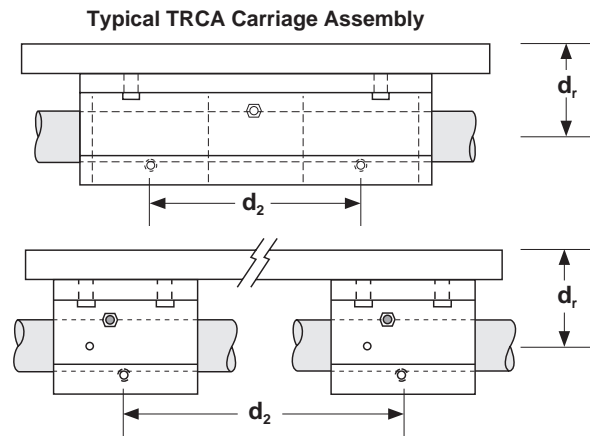

## TRCA Carriage Assemblies

| Model Number | Nominal Shaft Dia. (inches) | Carriage Length (inches) | Linear Bearing Used | Each Bearing <sup>(1)</sup> Dyn. Load Capacity (lbs) | Dyn. Load Capacity <sup>(1)</sup> (lbs) | d <sub>r</sub> (inches) | d <sub>1</sub> (inches) | d <sub>2</sub> (inches) |
|--------------|-----------------------------|--------------------------|---------------------|--|---|-------------------------|-------------------------|-------------------------|
| TRCA8-6      | 0.500                       | 6.00                     | DLBO-8              | 230  | 920                                     | 1.062                   | 3.00                    | 1.90                    |
| TRCA8-12     | 0.500                       | 12.00                    | SLBO-8              | 230  | 920                                     | 1.062                   | 3.00                    | 10.00                   |
| TRCA8-18     | 0.500                       | 18.00                    | SLBO-8              | 230  | 920                                     | 1.062                   | 3.00                    | 16.00                   |
| TRCA10-6     | 0.625                       | 6.00                     | DLBO-10             | 320  | 1,280                                   | 1.250                   | 3.75                    | 2.15                    |
| TRCA10-12    | 0.625                       | 12.00                    | SLBO-10             | 320  | 1,280                                   | 1.250                   | 3.75                    | 9.75                    |
| TRCA10-18    | 0.625                       | 18.00                    | SLBO-10             | 320  | 1,280                                   | 1.250                   | 3.75                    | 15.75                   |
| TRCA12-6     | 0.750                       | 6.00                     | DLBO-12             | 470  | 1,880                                   | 1.437                   | 4.50                    | 2.50                    |
| TRCA12-12    | 0.750                       | 12.00                    | SLBO-12             | 470  | 1,880                                   | 1.437                   | 4.50                    | 9.62                    |
| TRCA12-18    | 0.750                       | 18.00                    | SLBO-12             | 470  | 1,880                                   | 1.437                   | 4.50                    | 15.62                   |
| TRCA16-6     | 1.000                       | 6.00                     | DLBO-16             | 780  | 3,120                                   | 1.687                   | 5.25                    | 3.25                    |
| TRCA16-12    | 1.000                       | 12.00                    | SLBO-16             | 780  | 3,120                                   | 1.687                   | 5.25                    | 8.87                    |
| TRCA16-18    | 1.000                       | 18.00                    | SLBO-16             | 780  | 3,120                                   | 1.687                   | 5.25                    | 14.87                   |
| TRCA16-24    | 1.000                       | 24.00                    | SLBO-16             | 780  | 3,120                                   | 1.687                   | 5.25                    | 20.87                   |
| TRCA20-8     | 1.250                       | 8.00                     | DLBO-20             | 1,170  | 4,680                                   | 2.250                   | 6.00                    | 3.90                    |
| TRCA20-12    | 1.250                       | 12.00                    | SLBO-20             | 1,170  | 4,680                                   | 2.250                   | 6.00                    | 8.12                    |
| TRCA20-18    | 1.250                       | 18.00                    | SLBO-20             | 1,170  | 4,680                                   | 2.250                   | 6.00                    | 14.12                   |
| TRCA20-24    | 1.250                       | 24.00                    | SLBO-20             | 1,170  | 4,680                                   | 2.250                   | 6.00                    | 20.12                   |
| TRCA24-12    | 1.500                       | 12.00                    | DLBO-24             | 1,560  | 6,240                                   | 2.750                   | 6.62                    | 5.00                    |
| TRCA24-18    | 1.500                       | 18.00                    | SLBO-24             | 1,560  | 6,240                                   | 2.750                   | 6.62                    | 13.75                   |
| TRCA24-24    | 1.500                       | 24.00                    | SLBO-24             | 1,560  | 6,240                                   | 2.750                   | 6.62                    | 19.75                   |
| TRCA24-30    | 1.500                       | 30.00                    | SLBO-24             | 1,560  | 6,240                                   | 2.750                   | 6.62                    | 25.75                   |
| TRCA32-18    | 2.000                       | 18.00                    | SLBO-32             | 2,350  | 9,400                                   | 3.375                   | 7.25                    | 12.75                   |
| TRCA32-24    | 2.000                       | 24.00                    | SLBO-32             | 2,350  | 9,400                                   | 3.375                   | 7.25                    | 18.75                   |
| TRCA32-30    | 2.000                       | 30.00                    | SLBO-32             | 2,350  | 9,400                                   | 3.375                   | 7.25                    | 24.75                   |

### Footnotes:

(1) Rating based upon 2 million inches of travel with the load forces being applied downward on the linear bearing, while in a horizontal application, and based upon 1060 steel shafting (Rockwell 60C). The actual load rating, and life, is dependent upon factors detailed on pages 6 to 11.

## TRCA Rated Load Capacity

The dynamic load capacity of a *LINTECH* TRCA carriage assembly is based upon having the load forces centered on the carriage and the combined dynamic load capacity values of the SLBO or DLBO linear bearings used. The rated values are based on a  $L_{10}$  life of 2 million inches of travel (or 50 km) and with the load forces applied downward onto the carriage assembly.

For a given carriage assembly, as the load force decreases, the life of the carriage assembly will increase exponentially. The life of a carriage assembly, used in an application, can be determined by reviewing the load considerations found on pages 6 to 11.

## TRCA Rated Moment Loads

When using a *LINTECH* TRCA carriage assembly in an application, a moment load exists when the load center of gravity is located away from the center of the carriage assembly. The life of a carriage assembly is determined by the heaviest loaded linear bearing. Follow the steps below to determine if a specific TRCA carriage assembly will operate sufficiently in a given application.

**Step 1:** Calculate the forces acting on each of the individual bearings for a given configuration and TRCA carriage assembly by using the equations on page 11.

**Step 2:** Compare the calculated values with the rated dynamic load capacity values for the SLBO or DLBO linear bearings used on the TRCA carriage assembly. Make sure the calculated values are below the rated values. **Note:** If the calculated forces are acting on the open end of a linear bearing, reduce the rated dynamic load capacity of that bearing by the value shown on the Polar Charts found on page 9.

**Step 3:** Follow the information on pages 6 through 11 to determine the theoretical travel life of the selected carriage assembly in inches (or km) of travel.

### Load Centered on Carriage

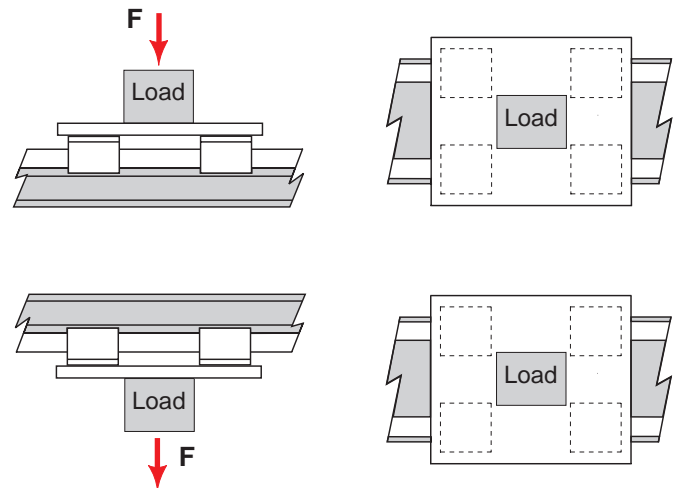

### Load Center away from Carriage Center

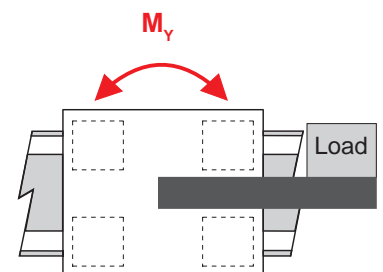
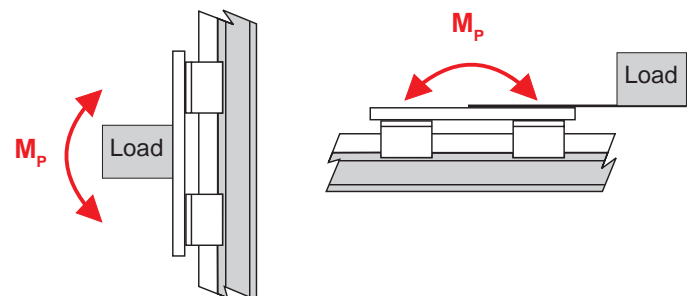
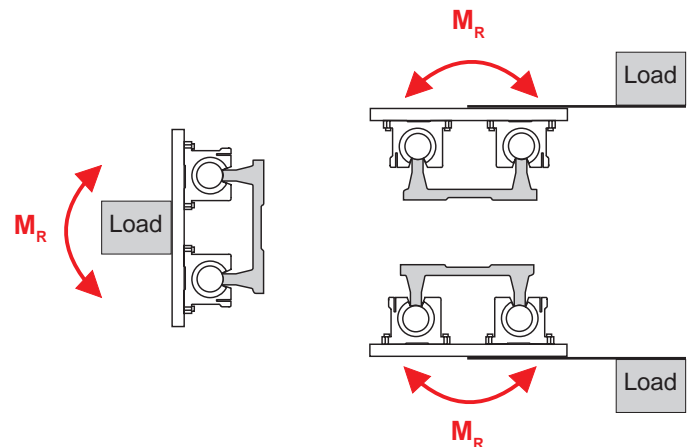

## Shaft Deflection

The equations below can be used when *LINTECH* closed linear bearings (LBC, LBCA, SLBC or DLBC series), and precision hardened shafting is used with shaft end supports (ES series), or with threaded shaft ends attached to a plate on each end. The estimated deflection that a configuration will experience is dependent upon the shaft diameter, unsupported shaft length, shaft material, along with the type and number of bearings being used.

Minimizing the deflection of the components will reduce additional stresses which can lead to premature failure. Excessive deflection can cause binding or rough operation when the bearings are at the area of travel furthest from the supported portion, which is usually at mid-stroke.

- D** = deflection (inches) (mm)
- W** = user applied load (lbs) (N)
- L** = length of unsupported shaft (inches) (mm)
- C** = distance from support to center of first bearing (inches) (mm)
- T** = shaft weight per length (lbs/in) (N/mm)
- S<sub>k</sub>** = strength constant - modulus of elasticity x moment of inertia

| Model Number | Nominal Shaft Diameter (inches) | Shaft Weight T (lbs/in) | Strength Factor S <sub>k</sub> (lb/in <sup>2</sup> ) |
|--------------|---------------------------------|-------------------------|--|
| <b>Sx4</b>   | 0.250                           | 0.014                   | 5,700  |
| <b>Sx6</b>   | 0.375                           | 0.031                   | 29,100   |
| <b>Sx8</b>   | 0.500                           | 0.055                   | 91,800   |
| <b>Sx10</b>  | 0.625                           | 0.086                   | 224,400  |
| <b>Sx12</b>  | 0.750                           | 0.125                   | 465,000  |
| <b>Sx16</b>  | 1.000                           | 0.222                   | 1,470,000  |
| <b>Sx20</b>  | 1.250                           | 0.348                   | 3,594,000  |
| <b>Sx24</b>  | 1.500                           | 0.500                   | 7,455,000  |
| <b>Sx32</b>  | 2.000                           | 0.890                   | 23,562,000   |

| Model Number | Nominal Shaft Diameter (mm) | Shaft Weight T (N/mm) | Strength Factor S <sub>k</sub> (N/mm <sup>2</sup> ) |
|--------------|-----------------------------|-----------------------|---|
| <b>SM8</b>   | 8                           | 0.0038                | 38.26   |
| <b>SM10</b>  | 10                          | 0.0061                | 93.41   |
| <b>SM12</b>  | 12                          | 0.0087                | 193.70  |
| <b>SM16</b>  | 16                          | 0.0154                | 612.20  |
| <b>SM20</b>  | 20                          | 0.0240                | 1,495.00  |
| <b>SM25</b>  | 25                          | 0.0379                | 3,649.00  |
| <b>SM30</b>  | 30                          | 0.0542                | 7,566.00  |
| <b>SM40</b>  | 40                          | 0.0968                | 23,910.00   |
| <b>SM50</b>  | 50                          | 0.1513                | 58,380.00   |

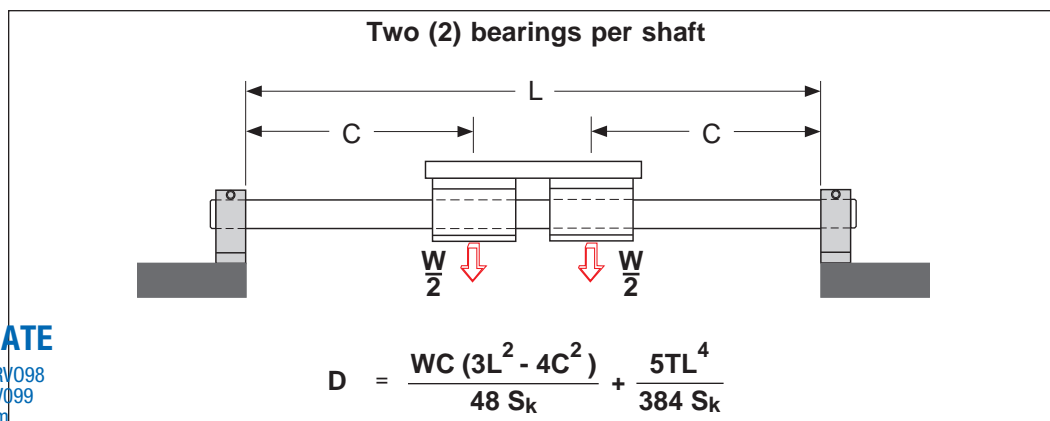
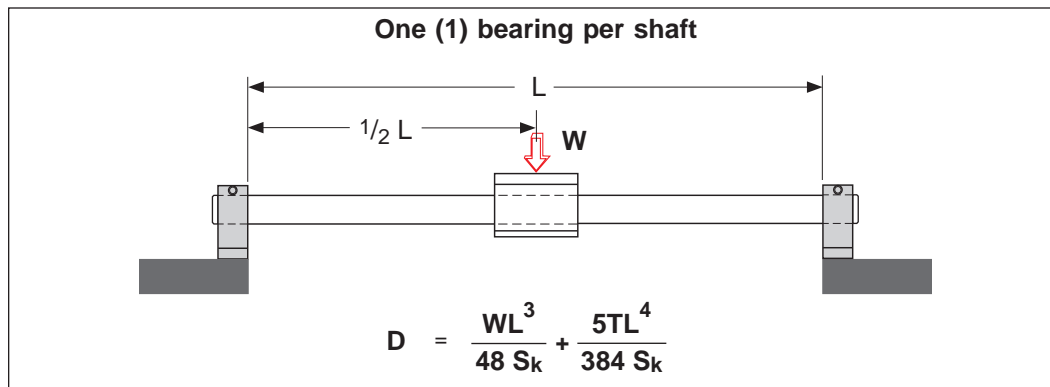

## Life Example

The following example is provided to aid in the understanding of how the various charts and equations in this technical section should be implemented. For this example, the life estimation will be determined for an application that will use a **LINTECH** TRCA carriage assembly with a TRSA shaft assembly.

## Application Parameters

The load weight of 100 lbs is centered on the TRCA carriage along with a 12 inch total travel in the horizontal plane. The **LINTECH** TRSA shaft assembly will use 440C stainless steel shafts, and will be mounted to a support structure so that the carriage will be inverted. Various outward moves will be made with a maximum return speed of 5 IPS. This return speed will be the most demanding speed profile in the application and the installation environment will be at 80° F.

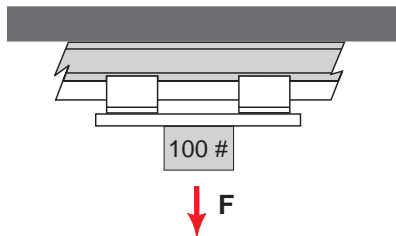

## Different Options

In the application below, utilizing a custom carriage length which has six (6) SLBO-12 pillow blocks instead of two (2) DLBO-12 pillow blocks on the TRCA12 carriage assembly, would increase the R value from 1,880 to 2,820 lbs. Thus, increasing the L life estimate value to 98,538,824 inches of travel from 29,196,688 inches of travel.

Another option would be to utilize chrome plated shafts for the TRSA assembly instead of the 440C stainless steel shafts. This would increase the shaft hardness factor to 1 instead of 0.52. Thus, increasing the L life estimate value to 207,646,00 inches of travel from 29,196,688 inches of travel for just using the standard TRCA12-6.

## Determine Safety and Correction Factors

- Step 1: Use chart on page 7 for 5 IPS to select a safety factor:  $S = 2$
- Step 2: Use chart on page 8 for 440C to select a shaft hardness factor:  $F_H = .52$
- Step 3: Use graph on page 8 for 80° F to select a temperature factor:  $F_T = 1$
- Step 4: Would like to use a TRCA12-6. From chart on page 12:  $R = 1,880$  lbs
- Step 5: Use polar graph on page 9 to select load direction factor:  $F_L = .5$
- Step 6: Use the equation on page 9 to compute the estimated life:

$$L = \left[ F_H \times F_T \times F_L \times \frac{R}{F \times S} \right]^3 \times B$$

$$L = \left[ .52 \times 1 \times .5 \times \frac{1880}{100 \times 2} \right]^3 \times 2,000,000$$

$$L = 29,196,688 \text{ inches of travel}$$

- Step 7: Use the equation on page 6 to determine the required life of your application. If the estimated L value above (for a 100 pound load) is less than your desired life, then select a larger carriage assembly from the chart on page 12, and then plug its dynamic load capacity for the R value into the equation above to re-calculate the estimated L life. As an example, the TRCA16-6 load rating of 3,120 lbs would increase the L life estimate to 133,451,615 inches of travel from 29,196,688 inches of travel.



## Shafting & Shaft Assembly Applications

**LINTECH** shafts, shaft assemblies, linear bearings, pillow blocks and carriage assemblies are used in many different applications requiring mechanical motion. These components are utilized with air cylinders, hydraulic actuators, lead screws, rack & pinion systems, belt & pulleys, chain & sprockets, as well as in manual positioning systems. **LINTECH** individual shafts or SA shaft assemblies, along with individual linear bearings or pillow blocks, are typically used when a designer wishes to spread apart the shafts or SA shaft assemblies and make a custom carriage assembly. The TRSA shaft assemblies and TRCA carriage assemblies are utilized together when ease of installation is of essence.

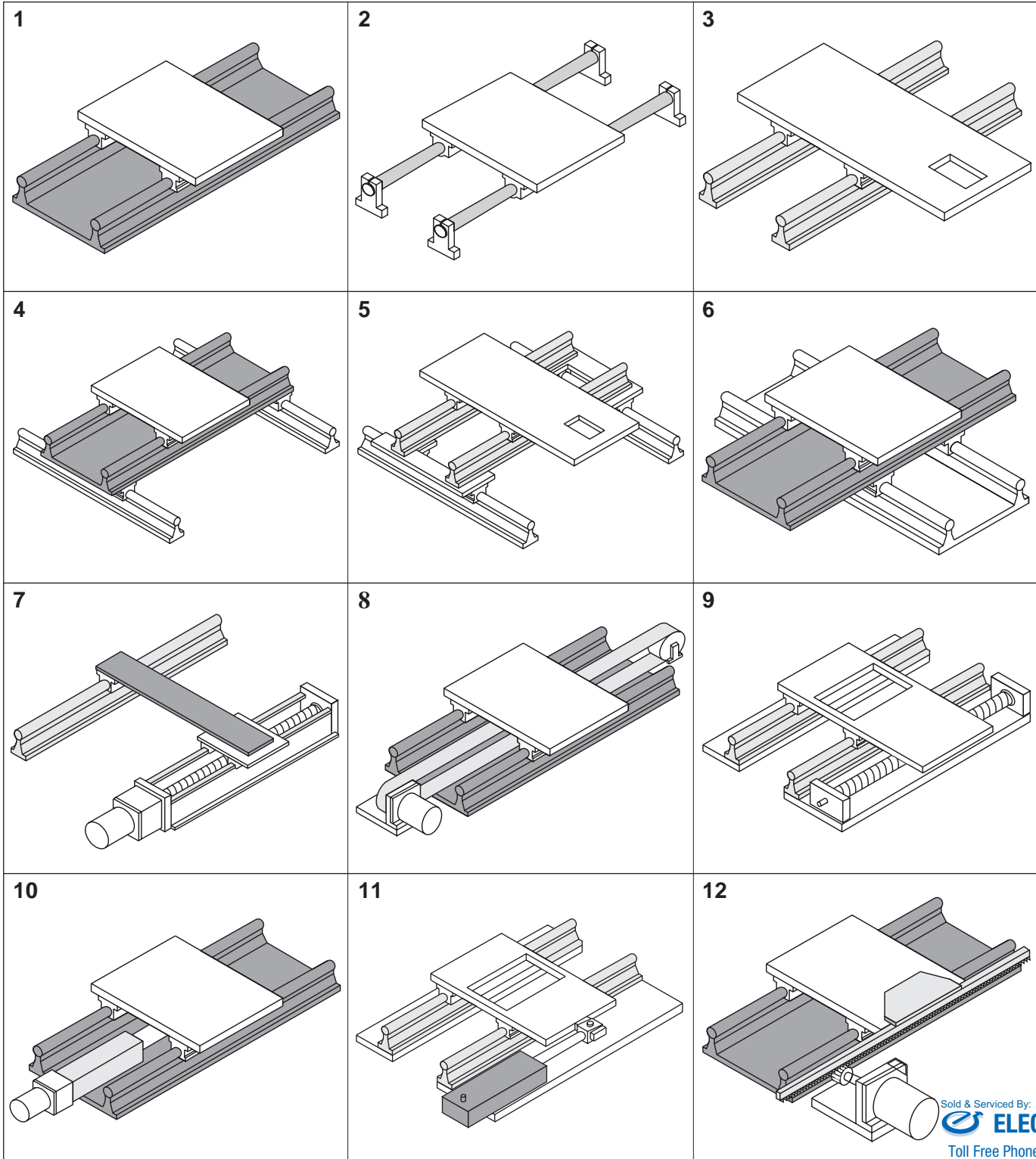

# Linear Bearings, Pillow Blocks and Carriage Assemblies

|                            |         |
|----------------------------|---------|
| LBCA & LBOA series _____   | 18 - 19 |
| LBC & LBO series _____     | 20 - 21 |
| LBCM & LBOM series _____   | 22 - 23 |
| LBCME & LBOME series _____ | 24 - 25 |
| Pillow Block series _____  | 26 - 28 |
| TRCA series _____          | 29 - 32 |
| Options _____              | 33 - 33 |
| Metric Pillow Blocks _____ | 34 - 35 |

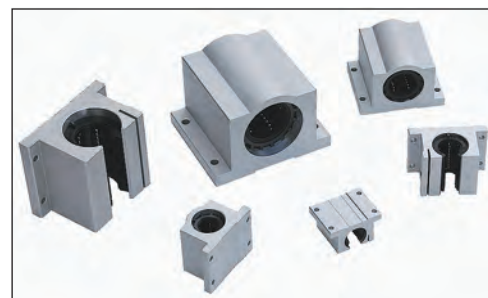

Sold & Serviced By:

 **ELECTROMATE**

Toll Free Phone (877) SERV098

Toll Free Fax (877) SERV099

[www.electromate.com](http://www.electromate.com)

[sales@electromate.com](mailto:sales@electromate.com)



**LBCA** - **12** - **S**

**Linear Bearing Series**

- LBCA** - One Precision linear bearing (closed - all steel)
- LBOA** - One Precision linear bearing (open - all steel)

**Nominal Diameter**

- 4** - 0.250 inch diameter
- 6** - 0.375 inch diameter
- 8** - 0.500 inch diameter
- 10** - 0.625 inch diameter
- 12** - 0.750 inch diameter
- 16** - 1.000 inch diameter
- 20** - 1.250 inch diameter
- 24** - 1.500 inch diameter
- 32** - 2.000 inch diameter

**Wiper Seals**

- No seals
- S** - Seals at both ends

## Specifications: LBCA & LBOA Linear Bearings

|   |   |  |                                     |   |   |   |
|---|---|--|-------------------------------------|---|---|---|
| <p><b>Operating Temperature</b></p> <p><b>Maximum Speed</b></p> <p><b>Bearing Seals</b> (optional)</p> <p><b>Matching Shaft</b></p> | <p>0° F to + 600° F (without seals)      0° F to + 185° F (with seals)</p> <p>10 ft/second</p> <p>Internal Wiper Seals on both ends, Plastic Bearing Retainer</p> <p>Class S (<b>SS</b> series), hardened &amp; ground shafting (see pages 38 - 39)</p> |  |                                     |   |   |   |
| <p><b>Housing Tolerances</b></p> <p>C = clearance</p>   | <p><b>LBCA</b><br/>(closed style)</p>   |  | <p><b>LBOA</b><br/>(open style)</p> |   |   |   |
|   | <p><b>Nominal Shaft Diameter</b><br/>(inches)</p>   | <p><b>Recommended Housing Bore</b></p> |                                     | <p><b>Bearing and Shaft Fit-up</b><br/>(inches)</p> | <p><b>Nominal Shaft Diameter</b><br/>(inches)</p> | <p><b>Recommended Housing Bore</b><br/>before adjustment<br/>(inches)</p> |
|   |   | <p>Normal Fit<br/>(inches)</p>         | <p>Press Fit<br/>(inches)</p>       |   |   |   |
|   | 0.250   | .5005 / .5000                          | .4995 / .4990                       | .0015C / .0005C                                     |   |   |
|   | 0.375   | .6255 / .6250                          | .6245 / .6240                       | .0015C / .0005C                                     |   |   |
|   | 0.500   | .8755 / .8750                          | .8745 / .8740                       | .0015C / .0005C                                     | 0.500   | .8760 / .8740   |
|   | 0.625   | 1.1255 / 1.1250                        | 1.1245 / 1.1240                     | .0015C / .0005C                                     | 0.625   | 1.1260 / 1.1240   |
|   | 0.750   | 1.2505 / 1.2500                        | 1.2495 / 1.2490                     | .0015C / .0005C                                     | 0.750   | 1.2510 / 1.2490   |
|   | 1.000   | 1.5630 / 1.5625                        | 1.5620 / 1.5615                     | .0015C / .0005C                                     | 1.000   | 1.5635 / 1.5615   |
|   | 1.250   | 2.0010 / 2.0000                        | 1.9993 / 1.9983                     | .0015C / .0004C                                     | 1.250   | 2.0010 / 1.9990   |
|   | 1.500   | 2.3760 / 2.3750                        | 2.3743 / 2.3733                     | .0016C / .0005C                                     | 1.500   | 2.3760 / 2.3740   |
|   | 2.000   | 3.0010 / 3.0000                        | 2.9992 / 2.9982                     | .0020C / .0005C                                     | 2.000   | 3.0010 / 2.9990   |

Dimensions & Specifications: **LBCA** Precision Linear Bearing (closed)

| Model Number  |                           | Nominal Shaft Diameter<br>(inches) | Working Bore Diameter<br>(inches) | Dyn. <sup>(1)</sup> Load Capacity<br>(lbs) | Dimensions<br>(inches) |             |       |               | Bearing Weight<br>(lbs) |
|---------------|---------------------------|------------------------------------|-----------------------------------|--|------------------------|-------------|-------|---------------|-------------------------|
| Without Seals | With Seals <sup>(2)</sup> |                                    |                                   |  | A                      | B           | C     | D             |                         |
| LBCA-4        | LBCA-4-S                  | 0.250                              | 0.2500/0.2495                     | 19   | 0.750/0.735            | 0.515/0.499 | 0.039 | 0.5000/0.4996 | 0.02                    |
| LBCA-6        | LBCA-6-S                  | 0.375                              | 0.3750/0.3745                     | 37   | 0.875/0.860            | 0.640/0.624 | 0.039 | 0.6250/0.6246 | 0.06                    |
| LBCA-8        | LBCA-8-S                  | 0.500                              | 0.5000/0.4995                     | 85   | 1.250/1.235            | 0.967/0.951 | 0.046 | 0.8750/0.8746 | 0.08                    |
| LBCA-10       | LBCA-10-S                 | 0.625                              | 0.6250/0.6245                     | 150  | 1.500/1.485            | 1.108/1.092 | 0.056 | 1.1250/1.1246 | 0.16                    |
| LBCA-12       | LBCA-12-S                 | 0.750                              | 0.7500/0.7495                     | 200  | 1.625/1.610            | 1.170/1.154 | 0.056 | 1.2500/1.2496 | 0.21                    |
| LBCA-16       | LBCA-16-S                 | 1.000                              | 1.0000/0.9995                     | 350  | 2.250/2.235            | 1.759/1.741 | 0.068 | 1.5625/1.5621 | 0.38                    |
| LBCA-20       | LBCA-20-S                 | 1.250                              | 1.2500/1.2494                     | 520  | 2.625/2.605            | 2.009/1.991 | 0.068 | 2.0000/1.9995 | 1.10                    |
| LBCA-24       | LBCA-24-S                 | 1.500                              | 1.5000/1.4994                     | 770  | 3.000/2.980            | 2.415/2.397 | 0.086 | 2.3750/2.3745 | 1.43                    |
| LBCA-32       | LBCA-32-S                 | 2.000                              | 2.0000/1.9992                     | 1,100                                      | 4.000/3.980            | 3.195/3.177 | 0.103 | 3.0000/2.9994 | 2.75                    |

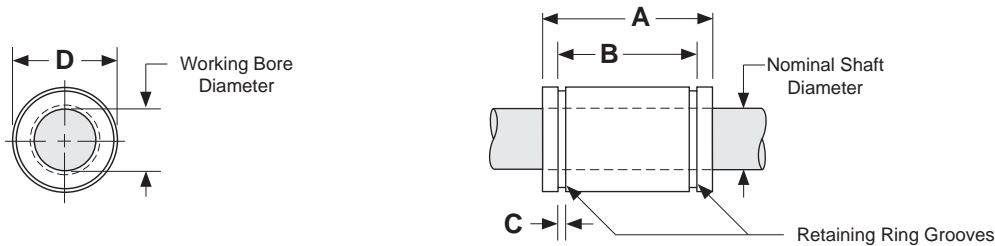

Dimensions & Specifications: **LBOA** Precision Linear Bearing (open)

| Model Number  |                           | Nominal Shaft Dia.<br>(inches) | Working Bore Diameter<br>(inches) | Dyn. <sup>(1)</sup> Load Cap.<br>(lbs) | Dimensions<br>(inches) |             |       |               |                   | Bearing Weight<br>(lbs) | Angle<br>$\alpha$ |
|---------------|---------------------------|--------------------------------|-----------------------------------|--|------------------------|-------------|-------|---------------|-------------------|-------------------------|-------------------|
| Without Seals | With Seals <sup>(2)</sup> |                                |                                   |  | A                      | B           | C     | D             | E <sub>min.</sub> |                         |                   |
| LBOA-8        | LBOA-8-S                  | 0.500                          | 0.5005/0.4995                     | 60                                     | 1.250/1.235            | 0.967/0.951 | 0.046 | 0.8760/0.8746 | 0.31              | 0.07                    | 50°               |
| LBOA-10       | LBOA-10-S                 | 0.625                          | 0.6255/0.6245                     | 105                                    | 1.500/1.485            | 1.108/1.092 | 0.056 | 1.1260/1.1240 | 0.38              | 0.11                    | 60°               |
| LBOA-12       | LBOA-12-S                 | 0.750                          | 0.7505/0.7495                     | 140                                    | 1.625/1.610            | 1.170/1.154 | 0.056 | 1.2510/1.2490 | 0.44              | 0.17                    | 60°               |
| LBOA-16       | LBOA-16-S                 | 1.000                          | 1.0005/0.9995                     | 240                                    | 2.250/2.235            | 1.759/1.741 | 0.068 | 1.5635/1.5615 | 0.56              | 0.32                    | 60°               |
| LBOA-20       | LBOA-20-S                 | 1.250                          | 1.2506/1.2494                     | 400                                    | 2.625/2.605            | 2.009/1.991 | 0.068 | 2.0010/1.9990 | 0.63              | 0.90                    | 50°               |
| LBOA-24       | LBOA-24-S                 | 1.500                          | 1.5006/1.4994                     | 600                                    | 3.000/2.980            | 2.415/2.397 | 0.086 | 2.3760/2.3740 | 0.75              | 1.12                    | 50°               |
| LBOA-32       | LBOA-32-S                 | 2.000                          | 2.0008/1.9992                     | 860                                    | 4.000/3.980            | 3.195/3.177 | 0.103 | 3.0010/2.9990 | 1.00              | 2.16                    | 50°               |

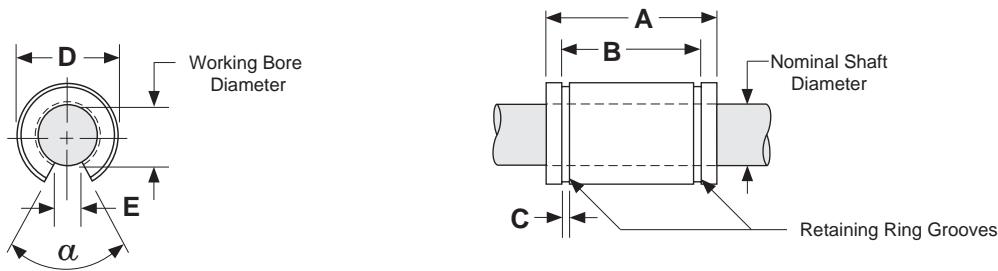

Footnotes:

- (1) Rating based upon 2 million inches of travel with the load forces being applied downward on the linear bearing, while in a horizontal application, and based upon 1060 steel shafting (Rockwell 60C). The actual load rating, and life, is dependent upon factors detailed on pages 6 to 11.
- (2) The bearing retainer is plastic when the internal -S seal option is selected.



**LBC** - **10** - **S**

**Linear Bearing Series**

**LBC** - One Linear Bearing Closed

**LBO** - One Linear Bearing Open

**Nominal Diameter**

- 4** - 0.250 inch diameter
- 6** - 0.375 inch diameter
- 8** - 0.500 inch diameter
- 10** - 0.625 inch diameter
- 12** - 0.750 inch diameter
- 16** - 1.000 inch diameter
- 20** - 1.250 inch diameter
- 24** - 1.500 inch diameter
- 32** - 2.000 inch diameter

**Bearing Options**

- No seals or corrosion resistance
- S** - Seals at both ends
- CR** - Corrosion Resistant without seals

## Specifications: **LBC** & **LBO** Linear Bearings (self-aligning)

|   |   |                                 |                             |  |                             |
|---|---|---------------------------------|-----------------------------|--|-----------------------------|
| <b>Operating Temperature</b>                              | 0° F to + 185° F  |                                 |                             |  |                             |
| <b>Maximum Speed</b>                                      | 9 ft/second   |                                 |                             |  |                             |
| <b>Bearing Seals</b>                                      | Optional Internal Wiper Seals on both ends                                  |                                 |                             |  |                             |
| <b>Matching Shaft</b>                                     | Class L ( <b>SL</b> series), hardened & ground shafting (see pages 38 - 39) |                                 |                             |  |                             |
| <b>Housing Tolerances</b><br>C = clearance<br>P = preload | <b>Nominal Shaft Diameter</b><br><br>(inches)                               | <b>Recommended Housing Bore</b> |                             | <b>Bearing and Shaft Fit-up<sup>(1)</sup></b><br>(before adjustment) |                             |
|   |   | Fixed Housing (inches)          | Adjustable Housing (inches) | Fixed Housing (inches)   | Adjustable Housing (inches) |
|   | 0.250   | .5005 / .5000                   | .5010 / .5000               | .0015C / .0000   | .002C / .0000               |
|   | 0.375   | .6255 / .6250                   | .6260 / .6250               | .0015C / .0000   | .002C / .0000               |
|   | 0.500   | .8755 / .8750                   | .8760 / .8750               | .0015C / .0000   | .002C / .0000               |
|   | 0.625   | 1.1255 / 1.1250                 | 1.1260 / 1.1250             | .0015C / .0000   | .002C / .0000               |
|   | 0.750   | 1.2505 / 1.2500                 | 1.2510 / 1.2500             | .0015C / .0000   | .002C / .0000               |
|   | 1.000   | 1.5630 / 1.5625                 | 1.5635 / 1.5625             | .0015C / .0000   | .002C / .0000               |
|   | 1.250   | 2.0008 / 2.0000                 | 2.0010 / 2.0000             | .0018C / .0001P  | .002C / .0000               |
|   | 1.500   | 2.3760 / 2.3750                 | 2.3760 / 2.3750             | .0021C / .0000   | .0021C / .0000              |
| 2.000   | 3.0010 / 3.0000   | 3.0010 / 3.0000                 | .0023C / .0002P             | .0023C / .0002P  |                             |

**Footnotes:**

(1) Adjustable Housing Diameter (before adjustment) for LBO-20 is .002C/.0001P.

## Dimensions & Specifications: **LBC** Linear Bearing (closed)

| Model Number  |               | Nominal Shaft Diameter (inches) | Dyn. <sup>(1)</sup> Load Capacity (lbs) | Working Bore Diameter (inches) | Housing Bore <sup>(2)</sup> D (inches) | Dimensions (inches) |             |       | Bearing Weight (lbs) |
|---------------|---------------|---------------------------------|---|--------------------------------|--|---------------------|-------------|-------|----------------------|
| Without Seals | With Seals    |                                 |   |                                |  | A                   | B           | C     |                      |
| LBC-4         | LBC-4-S       | 0.250                           | 60                                      | 0.2500/0.2495                  | 0.5005/0.5000                          | 0.750/0.735         | 0.511/0.501 | 0.039 | 0.01                 |
| LBC-6         | LBC-6-S       | 0.375                           | 105                                     | 0.3750/0.3745                  | 0.6255/0.6250                          | 0.875/0.860         | 0.699/0.689 | 0.039 | 0.02                 |
| LBC-8         | LBC-8-S       | 0.500                           | 265                                     | 0.5000/0.4995                  | 0.8755/0.8750                          | 1.250/1.230         | 1.032/1.012 | 0.050 | 0.04                 |
| LBC-10        | LBC-10-S      | 0.625                           | 420                                     | 0.6250/0.6245                  | 1.1255/1.1250                          | 1.500/1.480         | 1.105/1.095 | 0.056 | 0.10                 |
| LBC-12        | LBC-12-S      | 0.750                           | 640                                     | 0.7500/0.7495                  | 1.2505/1.2500                          | 1.625/1.605         | 1.270/1.250 | 0.056 | 0.14                 |
| LBC-16        | LBC-16-S      | 1.000                           | 1,045                                   | 1.0000/0.9995                  | 1.5630/1.5625                          | 2.250/2.230         | 1.884/1.864 | 0.068 | 0.25                 |
| LBC-20        | LBC-20-S      | 1.250                           | 1,585                                   | 1.2500/1.2494                  | 2.0008/2.0000                          | 2.625/2.600         | 2.004/1.984 | 0.068 | 0.45                 |
| LBC-24        | LBC-24-S      | 1.500                           | 1,930                                   | 1.5000/1.4994                  | 2.3760/2.3750                          | 3.000/2.970         | 2.410/2.390 | 0.086 | 0.85                 |
| LBC-32        | not available | 2.000                           | 3,000                                   | 2.0000/1.9992                  | 3.0010/3.0000                          | 4.000/3.960         | 3.193/3.163 | 0.105 | 1.45                 |

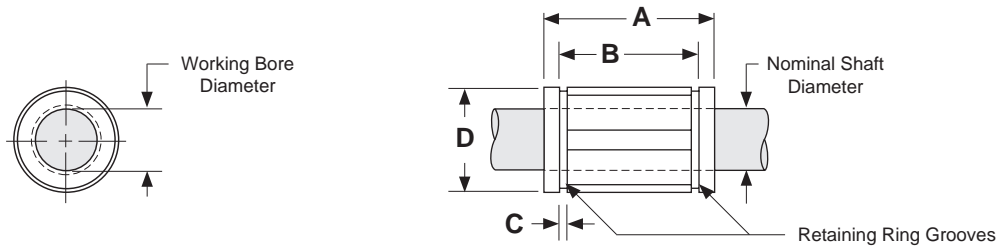

## Dimensions & Specifications: **LBO** Linear Bearing (open)

| Model Number  |               | Nominal Shaft Diameter (inches) | Dyn. <sup>(1)</sup> Load Capacity (lbs) | Working Bore Diameter (inches) | Housing Bore <sup>(2)</sup> D (inches) | Dimensions (inches) |             |       |        | Bearing Weight (lbs) |
|---------------|---------------|---------------------------------|---|--------------------------------|--|---------------------|-------------|-------|--------|----------------------|
| Without Seals | With Seals    |                                 |   |                                |  | A                   | B           | C     | E min. |                      |
| LBO-8         | LBO-8-S       | 0.500                           | 230                                     | 0.5000/0.4995                  | 0.8755/0.8750                          | 1.250/1.230         | 1.032/1.012 | 0.050 | 0.312  | 0.04                 |
| LBO-10        | LBO-10-S      | 0.625                           | 320                                     | 0.6250/0.6245                  | 1.1255/1.1250                          | 1.500/1.480         | 1.105/1.095 | 0.056 | 0.375  | 0.08                 |
| LBO-12        | LBO-12-S      | 0.750                           | 470                                     | 0.7500/0.7495                  | 1.2505/1.2500                          | 1.625/1.605         | 1.270/1.250 | 0.056 | 0.437  | 0.12                 |
| LBO-16        | LBO-16-S      | 1.000                           | 780                                     | 1.0000/0.9995                  | 1.5630/1.5625                          | 2.250/2.230         | 1.884/1.864 | 0.068 | 0.562  | 0.21                 |
| LBO-20        | LBO-20-S      | 1.250                           | 1,170                                   | 1.2500/1.2494                  | 2.0008/2.0000                          | 2.625/2.600         | 2.004/1.984 | 0.068 | 0.625  | 0.38                 |
| LBO-24        | LBO-24-S      | 1.500                           | 1,560                                   | 1.5000/1.4994                  | 2.3760/2.3750                          | 3.000/2.970         | 2.410/2.390 | 0.086 | 0.750  | 0.71                 |
| LBO-32        | not available | 2.000                           | 2,350                                   | 2.0000/1.9992                  | 3.0010/3.0000                          | 4.000/3.960         | 3.193/3.163 | 0.105 | 1.000  | 1.20                 |

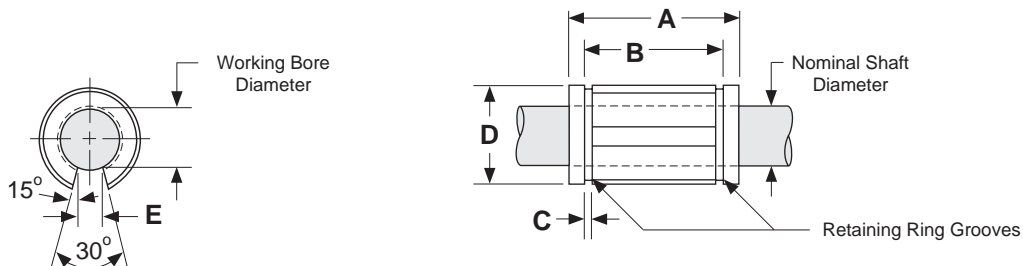

### Footnotes:

- (1) Rating based upon 2 million inches of travel with the load forces being applied downward on the linear bearing, while in a horizontal application, and based upon 1060 steel shafting (Rockwell 60C). The actual load rating, and life, is dependent upon factors detailed on pages 6 to 11.
- (2) This specification is based upon the bearing being on the shaft. Refer to page 38 for additional details.



**LBCM** - **16** - **S**

**Linear Bearing Closed Metric**

**LBCM** - Asian Style Super Metric Bearing Closed

**LBOM** - Asian Style Super Metric Bearing Open

**Nominal Diameter**

**16** - 16 mm diameter

**20** - 20 mm diameter

**25** - 25 mm diameter

**30** - 30 mm diameter

**40** - 40 mm diameter

**Bearing Options**

- No seals

**S** - Seals at both ends

**Specifications: LBCM & LBOM Linear Bearings Metric (self-aligning)**

|                              |  |                                   |
|------------------------------|--|-----------------------------------|
| <b>Operating Temperature</b> | -17.8° C to +85° C   |                                   |
| <b>Maximum Speed</b>         | 2,74 meters/second   |                                   |
| <b>Matching Shaft</b>        | Metric ( <b>SM</b> series), hardened & ground shafting (see pages 40 - 41) |                                   |
| <b>Housing Tolerances</b>    | <b>Nominal Shaft Diameter</b>  | <b>Recommended Housing Bore D</b> |
|                              | (mm)   | (mm)                              |
|                              | 16   | 28,10 / 28,03                     |
|                              | 20   | 32,10 / 32,05                     |
|                              | 25   | 40,10 / 40,05                     |
|                              | 30   | 45,15 / 45,05                     |
| 40                           | 60,15 / 60,05  |                                   |

## Dimensions & Specifications: LBCM Linear Bearing Closed Metric (Asian Style)

| Model Number  |            | Nominal Shaft Diameter (mm) | Dynamic Load Capacity N (Kgf) | Housing Bore D (mm) | Dimensions (mm) |      |      | No. of Ball Tracks | Bearing Weight (kg) |
|---------------|------------|-----------------------------|-------------------------------|---------------------|-----------------|------|------|--------------------|---------------------|
| Without Seals | With Seals |                             |                               |                     | A               | B    | C    |                    |                     |
| LBCM-16       | LBCM-16-S  | 16                          | 1225 (119,9)                  | 28                  | 37              | 26,5 | 1,60 | 5                  | 0,034               |
| LBCM-20       | LBCM-20-S  | 20                          | 2303 (239,8)                  | 32                  | 42              | 30,5 | 1,60 | 6                  | 0,058               |
| LBCM-25       | LBCM-25-S  | 25                          | 4312 (459,6)                  | 40                  | 59              | 41,0 | 1,85 | 6                  | 0,120               |
| LBCM-30       | LBCM-30-S  | 30                          | 4802 (569,6)                  | 45                  | 64              | 44,5 | 1,85 | 6                  | 0,148               |
| LBCM-40       | LBCM-40-S  | 40                          | 9310 (949,3)                  | 60                  | 80              | 60,5 | 2,10 | 6                  | 0,314               |

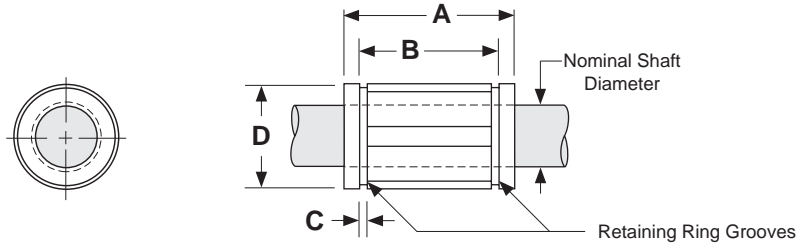

## Dimensions & Specifications: LBOM Linear Bearing Open Metric (Asian Style)

| Model Number  |            | Nominal Shaft Diameter (mm) | Dynamic Load Capacity N (Kgf) | Housing Bore D (mm) | Dimensions (mm) |      |      |        | Angle $\alpha$  | No. of Ball Tracks | Bearing Weight (kg) |
|---------------|------------|-----------------------------|-------------------------------|---------------------|-----------------|------|------|--------|-----------------|--------------------|---------------------|
| Without Seals | With Seals |                             |                               |                     | A               | B    | C    | E min. |                 |                    |                     |
| LBOM-16       | LBOM-16-S  | 16                          | 1372 (139,9)                  | 28                  | 37              | 26,5 | 1,60 | 11,0   | 60 <sup>0</sup> | 4                  | 0,026               |
| LBOM-20       | LBOM-20-S  | 20                          | 2332 (237,8)                  | 32                  | 42              | 30,5 | 1,60 | 11,0   | 60 <sup>0</sup> | 5                  | 0,048               |
| LBOM-25       | LBOM-25-S  | 25                          | 4351 (443,7)                  | 40                  | 59              | 41,0 | 1,85 | 12,5   | 60 <sup>0</sup> | 5                  | 0,100               |
| LBOM-30       | LBOM-30-S  | 30                          | 4851 (494,7)                  | 45                  | 64              | 44,5 | 1,85 | 15,0   | 60 <sup>0</sup> | 5                  | 0,122               |
| LBOM-40       | LBOM-40-S  | 40                          | 9408 (959,3)                  | 60                  | 80              | 60,5 | 2,15 | 20,0   | 60 <sup>0</sup> | 5                  | 0,260               |

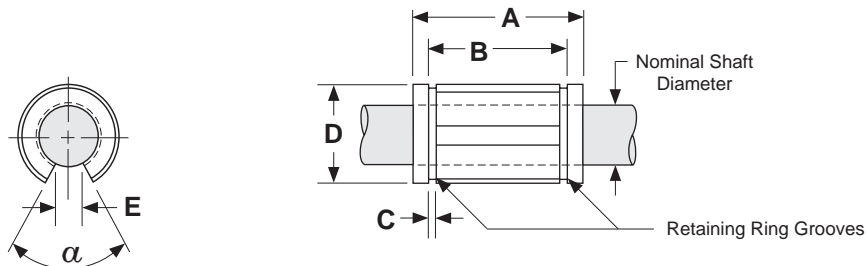

### Footnotes:

- (1) Rating based upon 50 km of travel with the load forces being applied downward on the linear bearing, while in a horizontal application, and based upon 1060 steel shafting (Rockwell 60C).
- (2) This specification is based upon the bearing being on the shaft.



# Ordering Guide

- Self-Aligning Metric (European Style) -

# LBCME & LBOME Series



**LBCME** - **16** - **S**

## Linear Bearing Closed Metric

**LBCME** - European ISO Super Metric Bearing Closed

**LBOME** - European ISO Super Metric Bearing Open

## Nominal Diameter

**16** - 16 mm diameter

**20** - 20 mm diameter

**25** - 25 mm diameter

**30** - 30 mm diameter

**40** - 40 mm diameter

**50** - 50 mm diameter

## Bearing Options

- No seals

**S** - Seals at both ends

## Specifications: **LBCME** & **LBOME** Linear Bearings Metric (self-aligning)

|                              |  |                                   |
|------------------------------|--|-----------------------------------|
| <b>Operating Temperature</b> | -17.8° C to +85° C   |                                   |
| <b>Maximum Speed</b>         | 2,74 meters/second   |                                   |
| <b>Matching Shaft</b>        | Metric ( <b>SM</b> series), hardened & ground shafting (see pages 40 - 41) |                                   |
| <b>Housing Tolerances</b>    | <b>Nominal Shaft Diameter</b>  | <b>Recommended Housing Bore D</b> |
|                              | (mm)   | (mm)                              |
|                              | 16   | 26,10 / 26,03                     |
|                              | 20   | 32,10 / 32,05                     |
|                              | 25   | 40,10 / 40,05                     |
|                              | 30   | 47,15 / 47,05                     |
|                              | 40   | 62,15 / 62,05                     |
| 50                           | 75,20 / 75,02  |                                   |

Sold & Serviced By:

 **ELECTROMATE**

Toll Free Phone (877) SERV098

Toll Free Fax (877) SERV099

[www.electromate.com](http://www.electromate.com)

[sales@electromate.com](mailto:sales@electromate.com)

# Technical Reference - Self-Aligning Metric (European Style) - LBCME & LBOME Series

## Dimensions & Specifications: **LBCME** Linear Bearing Closed Metric (European Style)

| Model Number  |            | Nominal Shaft Diameter<br>(mm) | Dynamic Load Capacity<br>N (Kgf) | Housing Bore D<br>(mm) | Dimensions<br>(mm) |      |      | No. of Ball Tracks | Bearing Weight<br>(kg) |
|---------------|------------|--------------------------------|----------------------------------|------------------------|--------------------|------|------|--------------------|------------------------|
| Without Seals | With Seals |                                |                                  |                        | A                  | B    | C    |                    |                        |
| LBCME-16      | LBCME-16-S | 16                             | 1176 (119,9)                     | 26                     | 36                 | 24,6 | 1,30 | 5                  | 0,026                  |
| LBCME-20      | LBCME-20-S | 20                             | 2352 (239,8)                     | 32                     | 45                 | 31,2 | 1,60 | 6                  | 0,060                  |
| LBCME-25      | LBCME-25-S | 25                             | 4508 (459,6)                     | 40                     | 58                 | 43,7 | 1,85 | 6                  | 0,120                  |
| LBCME-30      | LBCME-30-S | 30                             | 5586 (569,6)                     | 47                     | 68                 | 51,7 | 1,85 | 6                  | 0,184                  |
| LBCME-40      | LBCME-40-S | 40                             | 9310 (949,3)                     | 62                     | 80                 | 60,3 | 2,15 | 6                  | 0,342                  |
| LBCME-50      | LBCME-50-S | 50                             | 13720 (1399,0)                   | 75                     | 100                | 77,3 | 2,65 | 6                  | 0,586                  |

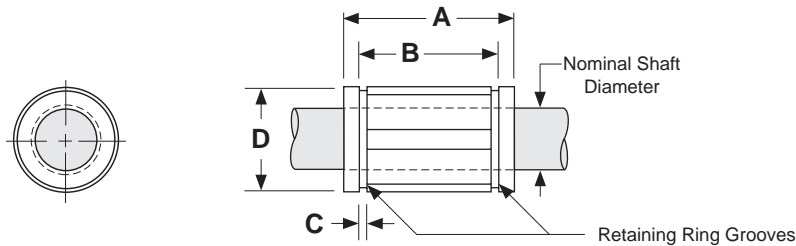

## Dimensions & Specifications: **LBOME** Linear Bearing Open Metric (European Style)

| Model Number  |            | Nominal Shaft Diameter<br>(mm) | Dynamic Load Capacity<br>N (Kgf) | Housing Bore D<br>(mm) | Dimensions<br>(mm) |      |      |           | Angle<br>$\alpha$ | No. of Ball Tracks | Bearing Weight<br>(kg) |
|---------------|------------|--------------------------------|----------------------------------|------------------------|--------------------|------|------|-----------|-------------------|--------------------|------------------------|
| Without Seals | With Seals |                                |                                  |                        | A                  | B    | C    | E<br>min. |                   |                    |                        |
| LBOME-16      | LBOME-16-S | 16                             | 1332 (135,8)                     | 26                     | 36                 | 24,6 | 1,30 | 9,0       | 68 <sup>0</sup>   | 4                  | 0,020                  |
| LBOME-20      | LBOME-20-S | 20                             | 2371 (241,8)                     | 32                     | 45                 | 31,2 | 1,60 | 9,0       | 55 <sup>0</sup>   | 5                  | 0,050                  |
| LBOME-25      | LBOME-25-S | 25                             | 4557 (464,7)                     | 40                     | 58                 | 43,7 | 1,85 | 11,5      | 57 <sup>0</sup>   | 5                  | 0,100                  |
| LBOME-30      | LBOME-30-S | 30                             | 5644 (575,5)                     | 47                     | 68                 | 51,7 | 1,85 | 14,0      | 57 <sup>0</sup>   | 5                  | 0,154                  |
| LBOME-40      | LBOME-40-S | 40                             | 9398 (958,3)                     | 62                     | 80                 | 60,3 | 2,15 | 19,5      | 56 <sup>0</sup>   | 5                  | 0,286                  |
| LBOME-50      | LBOME-50-S | 50                             | 13857 (1413,0)                   | 75                     | 100                | 77,3 | 2,65 | 22,5      | 54 <sup>0</sup>   | 5                  | 0,486                  |

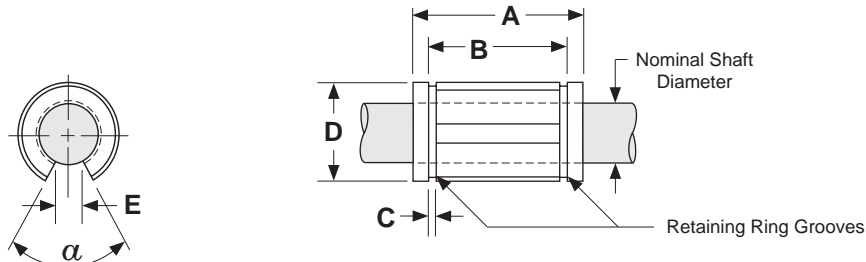

### Footnotes:

- (1) Rating based upon 50 km of travel with the load forces being applied downward on the linear bearing, while in a horizontal application, and based upon 1060 steel shafting (Rockwell 60C).
- (2) This specification is based upon the bearing being on the shaft.

Sold & Serviced By:

**ELECTROMATE**

Toll Free Phone (877) SERV098

Toll Free Fax (877) SERV099

www.electromate.com

sales@electromate.com

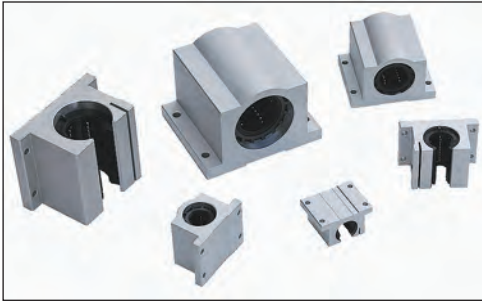

**SLBC** - **10** - **CR** - **L**

**Pillow Block Series** \_\_\_\_\_

- SLBC** - One LBC bearing per pillow block
- DLBC** - Two LBC bearings per pillow block
- SLBO** - One LBO bearing per pillow block
- DLBO** - Two LBO bearings per pillow block

**Nominal Diameter** \_\_\_\_\_

- 8** - 0.500 inch diameter
- 10** - 0.625 inch diameter
- 12** - 0.750 inch diameter
- 16** - 1.000 inch diameter
- 20** - 1.250 inch diameter
- 24** - 1.500 inch diameter
- 32** - 2.000 inch diameter (only in SLBC & SLBO style)

**Bearing Options** \_\_\_\_\_

- Standard
- CR** - Corrosion resistant

**Bearing Lock** \_\_\_\_\_

- None
- L** - Hand wheel lock

## Specifications: **SLBC, SLBO, DLBC & DLBO** Pillow Blocks (self-aligning)

| <b>Bearing Housing Type &amp; Finish</b> | Aluminum 6061-T6 Pillow Block, Clear Anodized   |                                    |                                      |       |               |       |               |       |               |       |               |       |                 |       |                 |       |                 |  |
|--|---|------------------------------------|--------------------------------------|-------|---------------|-------|---------------|-------|---------------|-------|---------------|-------|-----------------|-------|-----------------|-------|-----------------|--|
| <b>Bearing Seals</b>                     | Internal Wiper Seals on Both Ends   |                                    |                                      |       |               |       |               |       |               |       |               |       |                 |       |                 |       |                 |  |
| <b>Operating Temperature</b>             | 0° F to + 185° F  |                                    |                                      |       |               |       |               |       |               |       |               |       |                 |       |                 |       |                 |  |
| <b>Maximum Speed</b>                     | 9 ft/second   |                                    |                                      |       |               |       |               |       |               |       |               |       |                 |       |                 |       |                 |  |
| <b>Matching Shaft</b>                    | Class L ( <b>SL</b> series), hardened & ground shafting (see pages 38 - 39)   |                                    |                                      |       |               |       |               |       |               |       |               |       |                 |       |                 |       |                 |  |
| <b>Diameter Tolerance</b>                | <table border="1"> <thead> <tr> <th>Nominal Shaft Diameter<br/>(inches)</th> <th>Shaft Diameter Tolerance<br/>(inches)</th> </tr> </thead> <tbody> <tr> <td>0.500</td> <td>.4995 / .4990</td> </tr> <tr> <td>0.625</td> <td>.6245 / .6240</td> </tr> <tr> <td>0.750</td> <td>.7495 / .7490</td> </tr> <tr> <td>1.000</td> <td>.9995 / .9990</td> </tr> <tr> <td>1.250</td> <td>1.2495 / 1.2490</td> </tr> <tr> <td>1.500</td> <td>1.4994 / 1.4989</td> </tr> <tr> <td>2.000</td> <td>1.9994 / 1.9987</td> </tr> </tbody> </table> | Nominal Shaft Diameter<br>(inches) | Shaft Diameter Tolerance<br>(inches) | 0.500 | .4995 / .4990 | 0.625 | .6245 / .6240 | 0.750 | .7495 / .7490 | 1.000 | .9995 / .9990 | 1.250 | 1.2495 / 1.2490 | 1.500 | 1.4994 / 1.4989 | 2.000 | 1.9994 / 1.9987 |  |
| Nominal Shaft Diameter<br>(inches)       | Shaft Diameter Tolerance<br>(inches)  |                                    |                                      |       |               |       |               |       |               |       |               |       |                 |       |                 |       |                 |  |
| 0.500                                    | .4995 / .4990   |                                    |                                      |       |               |       |               |       |               |       |               |       |                 |       |                 |       |                 |  |
| 0.625                                    | .6245 / .6240   |                                    |                                      |       |               |       |               |       |               |       |               |       |                 |       |                 |       |                 |  |
| 0.750                                    | .7495 / .7490   |                                    |                                      |       |               |       |               |       |               |       |               |       |                 |       |                 |       |                 |  |
| 1.000                                    | .9995 / .9990   |                                    |                                      |       |               |       |               |       |               |       |               |       |                 |       |                 |       |                 |  |
| 1.250                                    | 1.2495 / 1.2490   |                                    |                                      |       |               |       |               |       |               |       |               |       |                 |       |                 |       |                 |  |
| 1.500                                    | 1.4994 / 1.4989   |                                    |                                      |       |               |       |               |       |               |       |               |       |                 |       |                 |       |                 |  |
| 2.000                                    | 1.9994 / 1.9987   |                                    |                                      |       |               |       |               |       |               |       |               |       |                 |       |                 |       |                 |  |

## Dimensions & Specifications: **SLBC** Single Linear Bearing Closed Pillow Block (self-aligning)

| Model Number | Nominal Shaft Diameter (inches) | Dyn. Load Capacity (lbs) | Dimensions (inches) |      |      |      |          |          |      |      |     |      |      | Block Weight (lbs) |
|--------------|---------------------------------|--------------------------|---------------------|------|------|------|----------|----------|------|------|-----|------|------|--------------------|
|              |                                 |                          | A                   | B    | C    | D    | E        | F        | G    | H    | I   | J    |      |                    |
|              |                                 |                          | +/- .003            |      |      |      | +/- .010 | +/- .010 |      |      |     | hole | bolt |                    |
| SLBC-8       | 0.500                           | 265                      | 0.687               | 2.00 | 1.69 | 1.13 | 1.688    | 1.000    | 1.38 | 1.25 | .25 | .16  | # 6  | 0.20               |
| SLBC-10      | 0.625                           | 420                      | 0.875               | 2.50 | 1.94 | 1.44 | 2.125    | 1.125    | 1.75 | 1.63 | .28 | .19  | # 8  | 0.50               |
| SLBC-12      | 0.750                           | 640                      | 0.937               | 2.75 | 2.06 | 1.56 | 2.375    | 1.250    | 1.88 | 1.75 | .31 | .19  | # 8  | 0.60               |
| SLBC-16      | 1.000                           | 1,045                    | 1.187               | 3.25 | 2.81 | 1.94 | 2.875    | 1.750    | 2.38 | 2.19 | .38 | .22  | #10  | 1.20               |
| SLBC-20      | 1.250                           | 1,585                    | 1.500               | 4.00 | 3.63 | 2.50 | 3.500    | 2.000    | 3.00 | 2.81 | .44 | .22  | #10  | 2.50               |
| SLBC-24      | 1.500                           | 1,930                    | 1.750               | 4.75 | 4.00 | 2.88 | 4.125    | 2.500    | 3.50 | 3.25 | .50 | .28  | 1/4  | 3.80               |
| SLBC-32      | 2.000                           | 3,000                    | 2.125               | 6.00 | 5.00 | 3.63 | 5.250    | 3.250    | 4.50 | 4.06 | .63 | .41  | 3/8  | 7.00               |

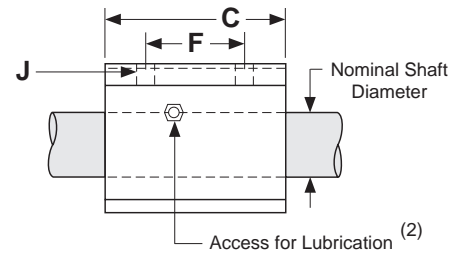
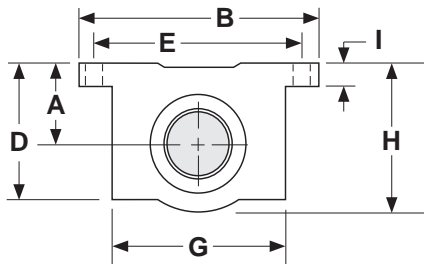

## Dimensions & Specifications: **SLBO** Single Linear Bearing Open Pillow Block (self-aligning)

| Model Number | Nominal Shaft Diameter (inches) | Dyn. Load Capacity (lbs) | Dimensions (inches) |      |      |      |          |          |      |      |      |     |      |      |      | Block Weight (lbs) |
|--------------|---------------------------------|--------------------------|---------------------|------|------|------|----------|----------|------|------|------|-----|------|------|------|--------------------|
|              |                                 |                          | A                   | B    | C    | D    | E        | F        | G    | H    |      | I   | J    | K    |      |                    |
|              |                                 |                          | +/- .003            |      |      |      | +/- .010 | +/- .010 |      | hole | bolt |     | min. |      |      |                    |
| SLBO-8       | 0.500                           | 230                      | 0.687               | 2.00 | 1.50 | 1.13 | 1.688    | 1.000    | 0.69 | .16  | # 6  | .25 | 0.31 | 0.75 | 0.20 |                    |
| SLBO-10      | 0.625                           | 320                      | 0.875               | 2.50 | 1.75 | 1.44 | 2.125    | 1.125    | 0.88 | .19  | # 8  | .28 | 0.37 | 0.94 | 0.40 |                    |
| SLBO-12      | 0.750                           | 470                      | 0.937               | 2.75 | 1.88 | 1.56 | 2.375    | 1.250    | 0.94 | .19  | # 8  | .31 | 0.43 | 1.00 | 0.50 |                    |
| SLBO-16      | 1.000                           | 780                      | 1.187               | 3.25 | 2.63 | 2.00 | 2.875    | 1.750    | 1.19 | .22  | #10  | .38 | 0.56 | 1.25 | 1.00 |                    |
| SLBO-20      | 1.250                           | 1,170                    | 1.500               | 4.00 | 3.38 | 2.56 | 3.500    | 2.000    | 1.50 | .22  | #10  | .44 | 0.62 | 1.63 | 2.10 |                    |
| SLBO-24      | 1.500                           | 1,560                    | 1.750               | 4.75 | 3.75 | 2.94 | 4.125    | 2.500    | 1.75 | .28  | 1/4  | .50 | 0.75 | 1.88 | 3.20 |                    |
| SLBO-32      | 2.000                           | 2,350                    | 2.125               | 6.00 | 4.75 | 3.63 | 5.250    | 3.250    | 2.25 | .41  | 3/8  | .63 | 1.00 | 2.44 | 6.00 |                    |

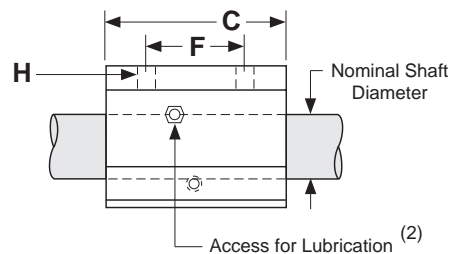
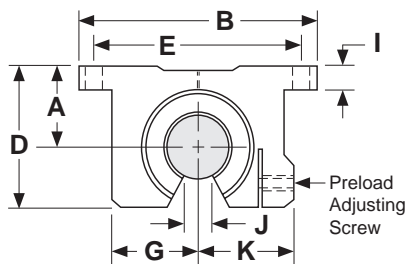

### Footnotes:

- (1) Rating based upon 2 million inches of travel with the load forces being applied downward on the linear bearing, while in a horizontal application, and based upon 1060 steel shafting (Rockwell 60C). The actual load rating, and life, is dependent upon factors detailed on pages 6 to 11.
- (2) Size 0.500 has oil lubricant fitting. Sizes 0.625 and above have a 1/4-28 UNF straight thread access for lubrication.

## Dimensions & Specifications: DLBC Double Linear Bearing Closed Pillow Block (self-aligning)

| Model Number | Nominal Shaft Diameter (inches) | Dyn. Load Capacity (lbs) <sup>(1)</sup> | Dimensions (inches) |      |      |      |          |          |      |      |     |     |      | Block Weight (lbs) |                               |
|--------------|---------------------------------|---|---------------------|------|------|------|----------|----------|------|------|-----|-----|------|--------------------|-------------------------------|
|              |                                 |   | A                   | B    | C    | D    | E        | F        | G    | H    | I   | J   |      |                    | d <sub>2</sub> <sup>(3)</sup> |
|              |                                 |   | +/- .003            |      |      |      | +/- .010 | +/- .010 |      |      |     |     | hole |                    |                               |
| DLBC-8       | 0.500                           | 510                                     | 0.687               | 2.00 | 3.50 | 1.13 | 1.688    | 2.500    | 1.38 | 1.25 | .25 | .16 | # 6  | 1.75               | 0.40                          |
| DLBC-10      | 0.625                           | 900                                     | 0.875               | 2.50 | 4.00 | 1.44 | 2.125    | 3.000    | 1.75 | 1.63 | .28 | .19 | # 8  | 2.00               | 1.00                          |
| DLBC-12      | 0.750                           | 1,200                                   | 0.937               | 2.75 | 4.50 | 1.56 | 2.375    | 3.500    | 1.88 | 1.75 | .31 | .19 | # 8  | 2.25               | 1.20                          |
| DLBC-16      | 1.000                           | 2,100                                   | 1.187               | 3.25 | 6.00 | 1.94 | 2.875    | 4.500    | 2.38 | 2.19 | .38 | .22 | #10  | 3.00               | 2.40                          |
| DLBC-20      | 1.250                           | 3,000                                   | 1.500               | 4.00 | 7.50 | 2.50 | 3.500    | 5.500    | 3.00 | 2.81 | .44 | .22 | #10  | 3.75               | 5.00                          |
| DLBC-24      | 1.500                           | 4,000                                   | 1.750               | 4.75 | 9.00 | 2.88 | 4.125    | 6.500    | 3.50 | 3.25 | .50 | .28 | 1/4  | 4.50               | 7.80                          |

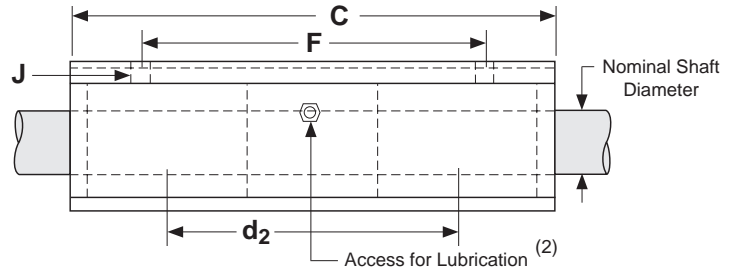
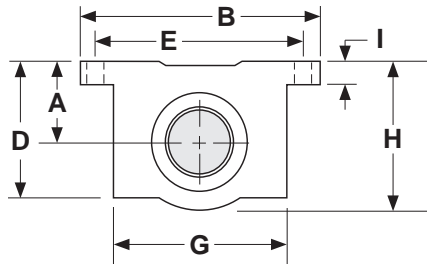

## Dimensions & Specifications: DLBO Double Linear Bearing Pillow Block Open (self-aligning)

| Model Number | Nominal Shaft Diameter (inches) | Dyn. Load Capacity (lbs) <sup>(1)</sup> | Dimensions (inches) |      |      |      |          |          |      |      |     |      |      |      |                               | Block Weight (lbs) |
|--------------|---------------------------------|---|---------------------|------|------|------|----------|----------|------|------|-----|------|------|------|-------------------------------|--------------------|
|              |                                 |   | A                   | B    | C    | D    | E        | F        | G    | H    | I   | J    |      | K    | d <sub>2</sub> <sup>(3)</sup> |                    |
|              |                                 |   | +/- .003            |      |      |      | +/- .010 | +/- .010 |      | min. |     | hole | bolt |      |                               |                    |
| DLBO-8       | 0.500                           | 460                                     | 0.687               | 2.00 | 3.50 | 1.13 | 1.688    | 2.500    | 0.69 | .31  | .25 | .16  | # 6  | 0.75 | 1.75                          | 0.40               |
| DLBO-10      | 0.625                           | 640                                     | 0.875               | 2.50 | 4.00 | 1.44 | 2.125    | 3.000    | 0.88 | .37  | .28 | .19  | # 8  | 0.94 | 2.00                          | 0.80               |
| DLBO-12      | 0.750                           | 940                                     | 0.937               | 2.75 | 4.50 | 1.56 | 2.375    | 3.500    | 0.94 | .43  | .31 | .19  | # 8  | 1.00 | 2.25                          | 1.00               |
| DLBO-16      | 1.000                           | 1,560                                   | 1.187               | 3.25 | 6.00 | 2.00 | 2.875    | 4.500    | 1.19 | .56  | .38 | .22  | #10  | 1.25 | 3.00                          | 2.00               |
| DLBO-20      | 1.250                           | 2,340                                   | 1.500               | 4.00 | 7.50 | 2.56 | 3.500    | 5.500    | 1.50 | .62  | .44 | .22  | #10  | 1.63 | 3.75                          | 4.20               |
| DLBO-24      | 1.500                           | 3,120                                   | 1.750               | 4.75 | 9.00 | 2.94 | 4.125    | 6.500    | 1.75 | .75  | .50 | .28  | 1/4  | 1.88 | 4.50                          | 6.70               |

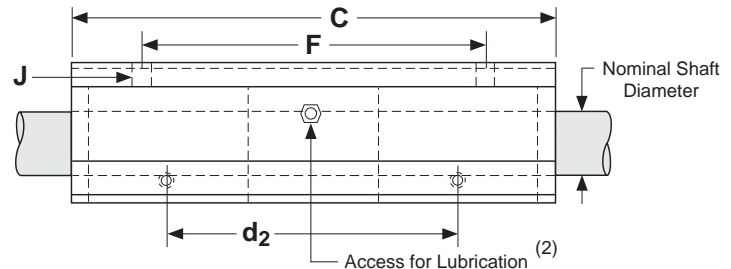
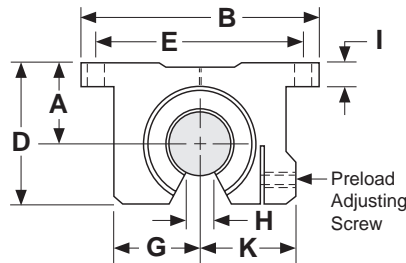

### Footnotes:

- (1) Rating based upon 2 million inches of travel with the load forces being applied downward on the linear bearing, while in a horizontal application, and based upon 1060 steel shafting (Rockwell 60C). The actual load rating, and life, is dependent upon factors detailed on pages 6 to 11.
- (2) Size 0.500 has oil lubricant fitting. Sizes 0.625 and above have a 1/4-28 UNF straight thread access for lubrication.
- (3) This value is the center to center distance (spacing) of the bearings on a single shaft (d<sub>2</sub>).

Sold & Serviced By:

**ELECTROMATE**

Toll Free Phone (877) SERV098

Toll Free Fax (877) SERV099

www.electromate.com

sales@electromate.com

Specifications subject to change without notice

**TRCA** - **12** - **12** - **CR** - **P** - **L1**

**TWIN RAIL® Carriage Assembly series**

**TRCA** - Plate with mounted SLBO or DLBO

**Nominal Bearing Diameter**

- 8** - 0.500 inch diameter
- 10** - 0.625 inch diameter
- 12** - 0.750 inch diameter
- 16** - 1.000 inch diameter
- 20** - 1.250 inch diameter
- 24** - 1.500 inch diameter
- 32** - 2.000 inch diameter

**Carriage Plate Length**

- 6** - 6 inches
- 8** - 8 inches
- 12** - 12 inches
- 18** - 18 inches
- 24** - 24 inches
- 30** - 30 inches

**Bearing Options**

- Standard
- CR** - Corrosion resistant

**Carriage Plate Mounting**

- No Holes
- P** - Pre-Machined Mounting holes

**Bearing Lock**

- None
- Lx** - Hand wheel locks (x = number of locks - 1, 2, 3 or 4)

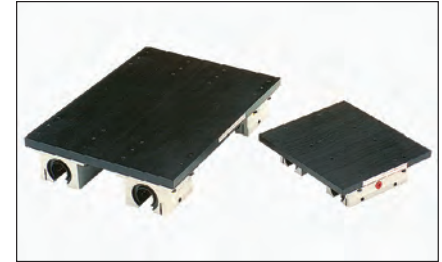

**Specifications: TRCA TWIN RAIL® Carriage Assembly**

| <b>Bearing Housing Type &amp; Finish</b> | Aluminum 6061-T6 Pillow Block, Clear Anodized   |                                    |                                      |       |               |       |               |       |               |       |               |       |                 |       |                 |       |                 |  |
|--|---|------------------------------------|--------------------------------------|-------|---------------|-------|---------------|-------|---------------|-------|---------------|-------|-----------------|-------|-----------------|-------|-----------------|--|
| <b>Bearing Seals</b>                     | Internal Wiper Seals on Both Ends   |                                    |                                      |       |               |       |               |       |               |       |               |       |                 |       |                 |       |                 |  |
| <b>Carriage Plate Type &amp; Finish</b>  | Machined Aluminum 6061-T6 Plate, Black Anodized   |                                    |                                      |       |               |       |               |       |               |       |               |       |                 |       |                 |       |                 |  |
| <b>Bearing Alignment on Plate</b>        | +/- 0.001", Pillow Blocks Doweled to Carriage Plate   |                                    |                                      |       |               |       |               |       |               |       |               |       |                 |       |                 |       |                 |  |
| <b>Operating Temperature</b>             | 0° F to + 185° F  |                                    |                                      |       |               |       |               |       |               |       |               |       |                 |       |                 |       |                 |  |
| <b>Maximum Speed</b>                     | 9 ft/second   |                                    |                                      |       |               |       |               |       |               |       |               |       |                 |       |                 |       |                 |  |
| <b>Matching Shaft Assembly</b>           | <b>TRSA</b> series (see page 47)  |                                    |                                      |       |               |       |               |       |               |       |               |       |                 |       |                 |       |                 |  |
| <b>Diameter Tolerance</b>                | <table border="1"> <thead> <tr> <th>Nominal Shaft Diameter<br/>(inches)</th> <th>Shaft Diameter Tolerance<br/>(inches)</th> </tr> </thead> <tbody> <tr> <td>0.500</td> <td>.4995 / .4990</td> </tr> <tr> <td>0.625</td> <td>.6245 / .6240</td> </tr> <tr> <td>0.750</td> <td>.7495 / .7490</td> </tr> <tr> <td>1.000</td> <td>.9995 / .9990</td> </tr> <tr> <td>1.250</td> <td>1.2495 / 1.2490</td> </tr> <tr> <td>1.500</td> <td>1.4994 / 1.4989</td> </tr> <tr> <td>2.000</td> <td>1.9994 / 1.9987</td> </tr> </tbody> </table> | Nominal Shaft Diameter<br>(inches) | Shaft Diameter Tolerance<br>(inches) | 0.500 | .4995 / .4990 | 0.625 | .6245 / .6240 | 0.750 | .7495 / .7490 | 1.000 | .9995 / .9990 | 1.250 | 1.2495 / 1.2490 | 1.500 | 1.4994 / 1.4989 | 2.000 | 1.9994 / 1.9987 |  |
| Nominal Shaft Diameter<br>(inches)       | Shaft Diameter Tolerance<br>(inches)  |                                    |                                      |       |               |       |               |       |               |       |               |       |                 |       |                 |       |                 |  |
| 0.500                                    | .4995 / .4990   |                                    |                                      |       |               |       |               |       |               |       |               |       |                 |       |                 |       |                 |  |
| 0.625                                    | .6245 / .6240   |                                    |                                      |       |               |       |               |       |               |       |               |       |                 |       |                 |       |                 |  |
| 0.750                                    | .7495 / .7490   |                                    |                                      |       |               |       |               |       |               |       |               |       |                 |       |                 |       |                 |  |
| 1.000                                    | .9995 / .9990   |                                    |                                      |       |               |       |               |       |               |       |               |       |                 |       |                 |       |                 |  |
| 1.250                                    | 1.2495 / 1.2490   |                                    |                                      |       |               |       |               |       |               |       |               |       |                 |       |                 |       |                 |  |
| 1.500                                    | 1.4994 / 1.4989   |                                    |                                      |       |               |       |               |       |               |       |               |       |                 |       |                 |       |                 |  |
| 2.000                                    | 1.9994 / 1.9987   |                                    |                                      |       |               |       |               |       |               |       |               |       |                 |       |                 |       |                 |  |

## Dimensions & Specifications: TRCA TWIN RAIL® Carriage Assembly

| Model Number | Nom. Shaft Dia. (inches) | Dyn. Load Cap. (lbs) | Dimensions (inches) |               |      |      |      |      |      |     |       |       |                               |                               |                               | Assembly Weight (lbs) |
|--------------|--------------------------|----------------------|---------------------|---------------|------|------|------|------|------|-----|-------|-------|-------------------------------|-------------------------------|-------------------------------|-----------------------|
|              |                          |                      | A<br>+/- .005       | B<br>+/- .005 | C    | D    | E    | F    | G    | H   | J     | K     | d <sub>r</sub> <sup>(2)</sup> | d <sub>1</sub> <sup>(3)</sup> | d <sub>2</sub> <sup>(4)</sup> |                       |
| TRCA8-6      | 0.500                    | 920                  | 6.00                | 5.50          | 1.25 | 0.75 | 0.68 | 1.12 | 2.00 | .25 | 3.50  | 0.375 | 1.062                         | 3.00                          | 1.90                          | 2.4                   |
| TRCA8-12     | 0.500                    | 920                  | 12.00               | 5.50          | 0.25 | 0.75 | 0.68 | 1.12 | 2.00 | .25 | 11.50 | 0.375 | 1.062                         | 3.00                          | 10.00                         | 4.6                   |
| TRCA8-18     | 0.500                    | 920                  | 18.00               | 5.50          | 0.25 | 0.75 | 0.68 | 1.12 | 2.00 | .25 | 17.50 | 0.375 | 1.062                         | 3.00                          | 16.00                         | 5.9                   |
| TRCA10-6     | 0.625                    | 1,280                | 6.00                | 6.75          | 1.00 | 0.93 | 0.87 | 1.43 | 2.50 | .25 | 4.00  | 0.375 | 1.250                         | 3.75                          | 2.15                          | 3.5                   |
| TRCA10-12    | 0.625                    | 1,280                | 12.00               | 6.75          | 0.25 | 0.93 | 0.87 | 1.43 | 2.50 | .25 | 11.50 | 0.375 | 1.250                         | 3.75                          | 9.75                          | 6.0                   |
| TRCA10-18    | 0.625                    | 1,280                | 18.00               | 6.75          | 0.25 | 0.93 | 0.87 | 1.43 | 2.50 | .25 | 17.50 | 0.375 | 1.250                         | 3.75                          | 15.75                         | 7.7                   |
| TRCA12-6     | 0.750                    | 1,880                | 6.00                | 7.75          | 0.75 | 1.00 | 0.93 | 1.56 | 2.75 | .25 | 4.50  | 0.500 | 1.437                         | 4.50                          | 2.50                          | 4.8                   |
| TRCA12-12    | 0.750                    | 1,880                | 12.00               | 7.75          | 0.25 | 1.00 | 0.93 | 1.56 | 2.75 | .25 | 11.49 | 0.500 | 1.437                         | 4.50                          | 9.62                          | 8.2                   |
| TRCA12-18    | 0.750                    | 1,880                | 18.00               | 7.75          | 0.25 | 1.00 | 0.93 | 1.56 | 2.75 | .25 | 17.49 | 0.500 | 1.437                         | 4.50                          | 15.62                         | 10.7                  |
| TRCA16-6     | 1.000                    | 3,120                | 6.00                | 9.00          | 0.00 | 1.25 | 1.18 | 2.00 | 3.25 | .25 | 6.00  | 0.500 | 1.687                         | 5.25                          | 3.25                          | 7.2                   |
| TRCA16-12    | 1.000                    | 3,120                | 12.00               | 9.00          | 0.25 | 1.25 | 1.18 | 2.00 | 3.25 | .25 | 11.49 | 0.500 | 1.687                         | 5.25                          | 8.87                          | 11.0                  |
| TRCA16-18    | 1.000                    | 3,120                | 18.00               | 9.00          | 0.25 | 1.25 | 1.18 | 2.00 | 3.25 | .25 | 17.49 | 0.500 | 1.687                         | 5.25                          | 14.87                         | 14.0                  |
| TRCA16-24    | 1.000                    | 3,120                | 24.00               | 9.00          | 0.25 | 1.25 | 1.18 | 2.00 | 3.25 | .25 | 23.49 | 0.500 | 1.687                         | 5.25                          | 20.87                         | 16.9                  |
| TRCA20-8     | 1.250                    | 4,680                | 8.00                | 10.50         | 0.25 | 1.62 | 1.50 | 2.56 | 4.00 | .25 | 7.50  | 0.750 | 2.250                         | 6.00                          | 3.90                          | 16.0                  |
| TRCA20-12    | 1.250                    | 4,680                | 12.00               | 10.50         | 0.25 | 1.62 | 1.50 | 2.56 | 4.00 | .25 | 11.49 | 0.750 | 2.250                         | 6.00                          | 8.12                          | 16.4                  |
| TRCA20-18    | 1.250                    | 4,680                | 18.00               | 10.50         | 0.25 | 1.62 | 1.50 | 2.56 | 4.00 | .25 | 17.49 | 0.750 | 2.250                         | 6.00                          | 14.12                         | 21.6                  |
| TRCA20-24    | 1.250                    | 4,680                | 24.00               | 10.50         | 0.25 | 1.62 | 1.50 | 2.56 | 4.00 | .25 | 23.49 | 0.750 | 2.250                         | 6.00                          | 20.12                         | 26.8                  |
| TRCA24-12    | 1.500                    | 6,240                | 12.00               | 12.00         | 1.50 | 1.87 | 1.75 | 2.93 | 4.75 | .31 | 9.00  | 1.000 | 2.750                         | 6.62                          | 5.00                          | 30.0                  |
| TRCA24-18    | 1.500                    | 6,240                | 18.00               | 12.00         | 0.25 | 1.87 | 1.75 | 2.93 | 4.75 | .31 | 17.50 | 1.000 | 2.750                         | 6.62                          | 13.75                         | 40.2                  |
| TRCA24-24    | 1.500                    | 6,240                | 24.00               | 12.00         | 0.25 | 1.87 | 1.75 | 2.93 | 4.75 | .31 | 23.50 | 1.000 | 2.750                         | 6.62                          | 19.75                         | 48.1                  |
| TRCA24-30    | 1.500                    | 6,240                | 30.00               | 12.00         | 0.25 | 1.87 | 1.75 | 2.93 | 4.75 | .31 | 29.50 | 1.000 | 2.750                         | 6.62                          | 25.75                         | 56.0                  |
| TRCA32-18    | 2.000                    | 9,400                | 18.00               | 14.00         | 0.25 | 2.43 | 2.25 | 3.62 | 6.00 | .37 | 17.50 | 1.250 | 3.375                         | 7.25                          | 12.75                         | 61.7                  |
| TRCA32-24    | 2.000                    | 9,400                | 24.00               | 14.00         | 0.25 | 2.43 | 2.25 | 3.62 | 6.00 | .37 | 23.50 | 1.250 | 3.375                         | 7.25                          | 18.75                         | 73.2                  |
| TRCA32-30    | 2.000                    | 9,400                | 30.00               | 14.00         | 0.25 | 2.43 | 2.25 | 3.62 | 6.00 | .37 | 29.50 | 1.250 | 3.375                         | 7.25                          | 24.75                         | 84.8                  |

### Footnotes:

- (1) Rating based upon 2 million inches of travel with the load forces being applied downward on the linear bearing, while in a horizontal application, and based upon 1060 steel shafting (Rockwell 60C). The actual load rating, and life, is dependent upon factors detailed on pages 6 to 11.
- (2) This value is the center distance of the bearing to the top of the carriage plate surface (d<sub>r</sub>).
- (3) This value is the center to center distance (spread) between the rails (d<sub>1</sub>).
- (4) This value is the center to center distance (spacing) of the bearings on a single shaft (d<sub>2</sub>).

## Dimensions

(inches)

**Available For:**

TRCA8-6, TRCA10-6, TRCA12-6,  
TRCA16-6, TRCA20-8, TRCA24-12

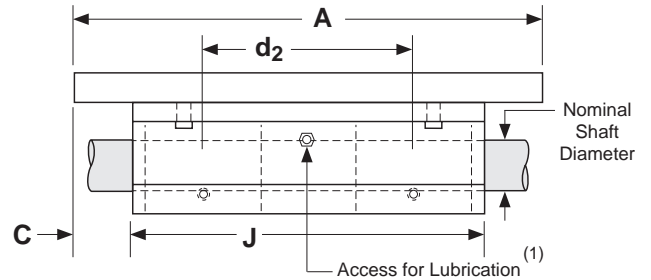
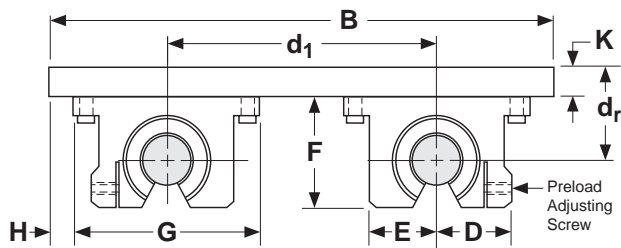

**Available For:**

All other TRCA models,  
not shown above

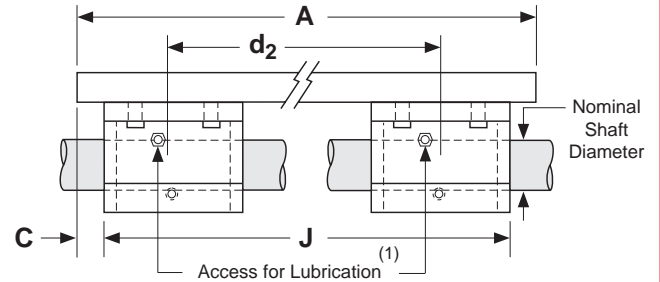
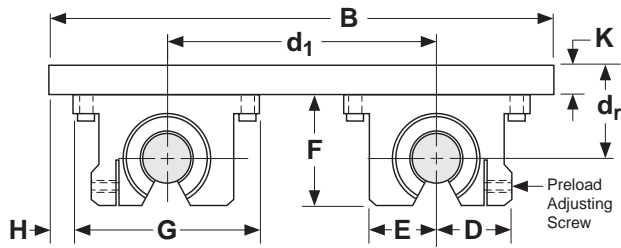

**Footnotes:**

(1) Size 0.500 has oil lubricant fitting. Sizes 0.625 and above have a 1/4-28 UNF straight thread access for lubrication.



### ( -P ) Pre-Machined Carriage Mounting Holes

All carriage assembly plates are available with a pre-determined number & location of mounting holes. These holes consist of stainless steel threaded inserts per the below chart. Custom mounting patterns are available upon request.

| Model Number | Carriage Length<br>(inches) | L<br>(inches) | Threaded Insert Size |
|--------------|-----------------------------|---------------|----------------------|
| TRCA8-6-P    | 6.00                        | 5.00          | #10-32               |
| TRCA8-12-P   | 12.00                       | 5.00          | #10-32               |
| TRCA8-18-P   | 18.00                       | 5.00          | #10-32               |
| TRCA10-6-P   | 6.00                        | 5.00          | #10-32               |
| TRCA10-12-P  | 12.00                       | 5.00          | #10-32               |
| TRCA10-18-P  | 18.00                       | 5.50          | #10-32               |
| TRCA12-6-P   | 6.00                        | 5.00          | 1/4-28               |
| TRCA12-12-P  | 12.00                       | 5.00          | 1/4-28               |
| TRCA12-18-P  | 18.00                       | 5.50          | 1/4-28               |
| TRCA16-6-P   | 6.00                        | 5.00          | 5/16-24              |
| TRCA16-12-P  | 12.00                       | 5.00          | 5/16-24              |
| TRCA16-18-P  | 18.00                       | 5.00          | 5/16-24              |
| TRCA16-24-P  | 24.00                       | 5.00          | 5/16-24              |
| TRCA20-8-P   | 8.00                        | 7.00          | 3/8-24               |
| TRCA20-12-P  | 12.00                       | 5.00          | 3/8-24               |
| TRCA20-18-P  | 18.00                       | 5.00          | 3/8-24               |
| TRCA20-24-P  | 24.00                       | 5.00          | 3/8-24               |
| TRCA24-12-P  | 12.00                       | 5.00          | 3/8-24               |
| TRCA24-18-P  | 18.00                       | 5.00          | 3/8-24               |
| TRCA24-24-P  | 24.00                       | 5.00          | 3/8-24               |
| TRCA24-30-P  | 30.00                       | 5.25          | 3/8-24               |
| TRCA32-18-P  | 18.00                       | 5.00          | 1/2-20               |
| TRCA32-24-P  | 24.00                       | 5.00          | 1/2-20               |
| TRCA32-30-P  | 30.00                       | 5.25          | 1/2-20               |

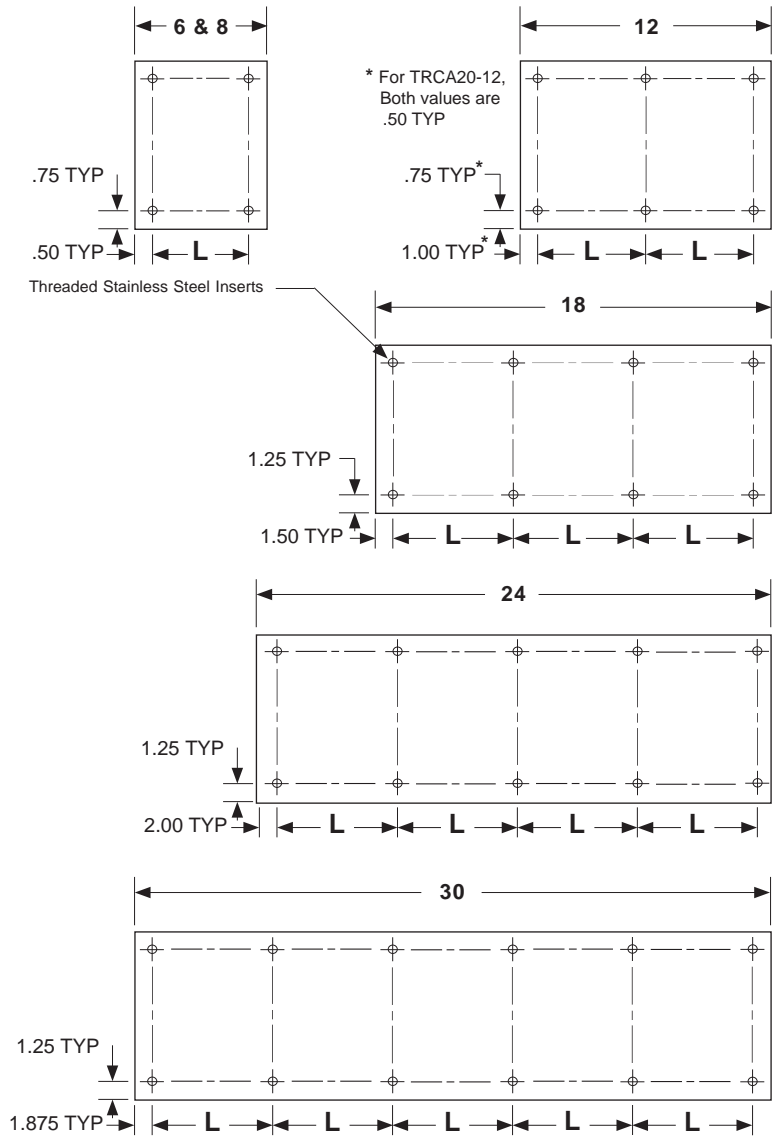

# Options

## ( -L ) Hand Wheel Lock

This option adds an aluminum clamping block to the end of a pillow block, which then provides for a manual lock of the bearing to the shaft. The threaded hand wheel shaft presses into a bronze insert which makes contact to provide a "pressure lock" to the shaft. The threaded steel screw will not back drive and does not make physical contact with the steel shaft (no steel to steel contact). The lock will be installed as shown below when ordered with a SLBC, SLBO, DLBC, DLBO, or TRCA series. Multiple locks can be installed onto a TRCA assembly.

| Nominal Shaft Diameter (inches) | Dimensions (inches) |      |      |      |      |        |      |
|---------------------------------|---------------------|------|------|------|------|--------|------|
|                                 | A                   | B    | C    | D    | E    |        | F    |
|                                 |                     |      |      |      | open | closed |      |
| 8 - 0.500                       | 1.680               | 1.72 | 2.00 | 0.50 | .56  | .44    | 2.00 |
| 10 - 0.625                      | 1.875               | 1.53 | 2.00 | 0.50 | .50  | .31    | 2.50 |
| 12 - 0.750                      | 2.067               | 1.46 | 2.00 | 0.50 | .37  | .18    | 2.75 |
| 16 - 1.000                      | 2.312               | 1.34 | 2.00 | 0.50 | .19  | ---    | 3.25 |
| 20 - 1.250                      | 3.125               | 1.66 | 2.50 | 0.75 | .17  | ---    | 4.00 |
| 24 - 1.500                      | 3.625               | 1.46 | 2.50 | 0.75 | .05  | ---    | 4.75 |
| 32 - 2.000                      | 4.600               | 1.45 | 2.50 | 0.75 | ---  | ---    | 6.00 |

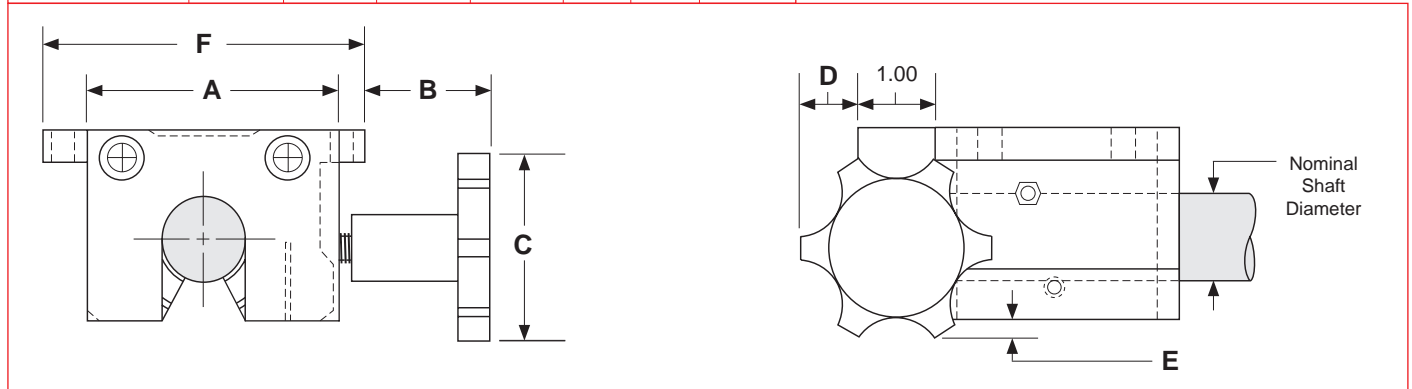

## Custom Carriage Sizes

Custom carriage sizes that need to be wider, or longer than shown in this catalog can be provided upon request. This will allow for larger rail and bearing spacing ( $d_1$  &  $d_2$  dimensions).

## Custom Carriage Material & Finishes

The standard carriage material is aluminum with a black anodized finish. Aluminum plates can be finished in many different colors, while steel carriage plates can be provided with a black oxide finish. Many other custom alternatives for carriage plates are available.

## Special Grease Options

Bearings can be supplied with special greases, or lubricants, in order to meet the environmental requirements of the application. Examples of operating environments which may require a special lubricant include: high or low temperature, clean rooms, vacuums and food grade applications.

## SLBCM Series

Single Self-Aligning Closed

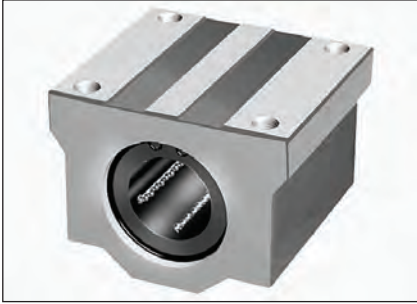

## SLBCM-A Series

Single Self-Aligning Closed Adjustable

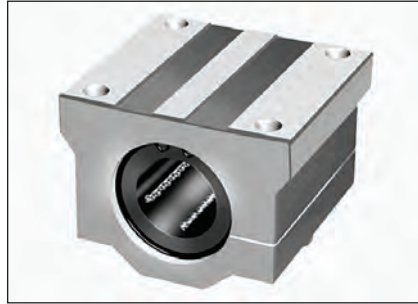

## SLBOM Series

Single Self-Aligning Open



## DLBCM Series

Double Self-Aligning Closed



## SLBCME Series

Single Self-Aligning Closed



## SLBCME-A Series

Single Self-Aligning Closed Adjustable



## SLBOME Series

Single Self-Aligning Open



## SLBOME-A Series

Single Self-Aligning Open Adjustable



## DLBCME Series

Double Self-Aligning Closed



## DLBCME-A Series

Single Self-Aligning Closed Adjustable



## DLBOME Series

Double Self-Aligning Open



## DLBOME-A Series

Double Self-Aligning Open Adjustable



Sold & Serviced By:

 **ELECTROMATE**

Toll Free Phone (877) SERV098

Toll Free Fax (877) SERV099

[www.electromate.com](http://www.electromate.com)

[sales@electromate.com](mailto:sales@electromate.com)

# Notes

---

Sold & Serviced By:



Toll Free Phone (877) SERV098

Toll Free Fax (877) SERV099

[www.electromate.com](http://www.electromate.com)

[sales@electromate.com](mailto:sales@electromate.com)

---

# Shafting, Shaft Supports and Shaft Assembly Products

|                                 |         |
|---------------------------------|---------|
| Precision Linear Shafting _____ | 38 - 41 |
| Shaft Supports _____            | 42 - 45 |
| SA series _____                 | 48 - 55 |
| TRSA series _____               | 56 - 63 |
| Options _____                   | 64 - 65 |

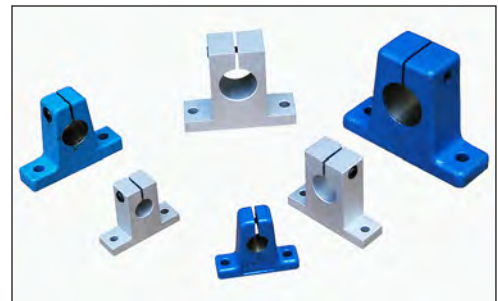



**SL** **12** - **SS** - **PD** x **105.375**

**Shafting** \_\_\_\_\_

- SL** - Class L diameter tolerance
- SS** - Class S diameter tolerance
- SN** - Class N diameter tolerance

**Shaft Diameter** \_\_\_\_\_

- 4** - 0.250 inch diameter
- 6** - 0.375 inch diameter
- 8** - 0.500 inch diameter
- 10** - 0.625 inch diameter
- 12** - 0.750 inch diameter
- 16** - 1.000 inch diameter
- 20** - 1.250 inch diameter
- 24** - 1.500 inch diameter
- 32** - 2.000 inch diameter

**Shaft Material** \_\_\_\_\_

- 1060 Steel
- SS** - 440C Stainless Steel (not available in class N)
- CR** - Chrome Plated 1060 Steel

**Pre-Drilled** \_\_\_\_\_

- No mounting hole pattern
- PD** - pre-drilled hole pattern

**Overall Length** \_\_\_\_\_

**xxx.xxx** - inches for all series

## Specifications: SL, SS & SN Inch Precision Shafting

|   |  |   |   |   |   |
|---|--|---|---|---|---|
| <b>Shaft Straightness<sup>(1)</sup></b> | 0.001/0.002 in/ft, cumulative  |   |   |   |   |
| <b>Shaft Type</b>                       | 1060 Steel or 440C Stainless steel (only with L & S tolerance)                           |   |   |   |   |
| <b>Shaft Roundness</b>                  | 0.000080 inches  |   |   |   |   |
| <b>Shaft Chamfer</b>                    | For 0.25 - 0.75 inch dia. : 0.03 inch x 45°, For 1.00 - 2.00 inch dia. : 0.06 inch x 45° |   |   |   |   |
| <b>Surface Finish</b>                   | 8 - 12 R <sub>a</sub> microinch  |   |   |   |   |
| <b>Diameter Tolerance</b>               | <b>Nominal Shaft Diameter</b><br>(inches)  | <b>Class L Diameter Tolerance</b><br>(inches) | <b>Class S Diameter Tolerance</b><br>(inches) | <b>Class N Diameter Tolerance</b><br>(inches) | <b>Minimum Hardness Depth</b><br>(inches) |
| <b>Hardness Depth</b>                   | 0.250  | .2495 / .2490                                 | .2490 / .2485                                 | .2500 / .2498                                 | 0.040                                     |
|   | 0.375  | .3745 / .3740                                 | .3740 / .3735                                 | .3750 / .3748                                 | 0.040                                     |
|   | 0.500  | .4995 / .4990                                 | .4990 / .4985                                 | .5000 / .4998                                 | 0.040                                     |
|   | 0.625  | .6245 / .6240                                 | .6240 / .6235                                 | .6250 / .6248                                 | 0.040                                     |
|   | 0.750  | .7495 / .7490                                 | .7490 / .7485                                 | .7500 / .7498                                 | 0.060                                     |
|   | 1.000  | .9995 / .9990                                 | .9990 / .9985                                 | 1.0000 / .9998                                | 0.080                                     |
|   | 1.250  | 1.2495 / 1.2490                               | 1.2490 / 1.2485                               | 1.2500 / 1.2498                               | 0.080                                     |
|   | 1.500  | 1.4994 / 1.4989                               | 1.4989 / 1.4984                               | 1.5000 / 1.4997                               | 0.080                                     |
|   | 2.000  | 1.9994 / 1.9987                               | 1.9987 / 1.9980                               | 2.0000 / 1.9997                               | 0.100                                     |

**Footnotes:**

(1) Straightness of .0005/.001 in/ft cumulative is available. Contact the factory.

## Dimensions & Specifications: SL, SS & SN Inch Precision Shafting

| Model Number | Nominal Shaft Diameter (inches) | Maximum Length       |     |                      |     | Shaft Weight (lbs/in) |                  |
|--------------|---------------------------------|----------------------|-----|----------------------|-----|-----------------------|------------------|
|              |                                 | Class L -SS (inches) |     | Class S -SS (inches) |     |                       | Class N (inches) |
| Sx4          | 0.250                           | 96                   | 144 | 96                   | 144 | 96                    | 0.014            |
| Sx6          | 0.375                           | 172                  | 154 | 172                  | 154 | 172                   | 0.031            |
| Sx8          | 0.500                           | 184                  | 154 | 184                  | 154 | 184                   | 0.055            |
| Sx10         | 0.625                           | 184                  | 154 | 184                  | 154 | 184                   | 0.086            |
| Sx12         | 0.750                           | 184                  | 154 | 184                  | 154 | 184                   | 0.125            |
| Sx16         | 1.000                           | 184                  | 154 | 184                  | 154 | 184                   | 0.222            |
| Sx20         | 1.250                           | 184                  | 154 | 184                  | 154 | 184                   | 0.348            |
| Sx24         | 1.500                           | 184                  | 154 | 184                  | 154 | 184                   | 0.500            |
| Sx32         | 2.000                           | 184                  | 154 | 184                  | 154 | 184                   | 0.890            |

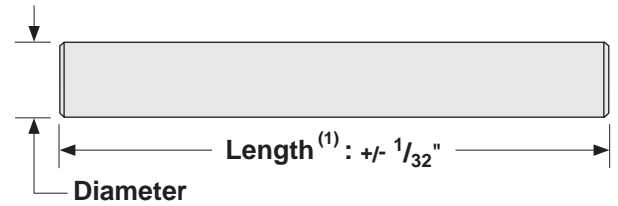

## Dimensions & Specifications: SL-PD Inch Precision Shafting

| Model Number | Nominal Shaft Diameter (inches) | Maximum Length |     | Pre-Drilled Holes (inches) |      |         | Shaft Weight (lbs/in) |
|--------------|---------------------------------|----------------|-----|----------------------------|------|---------|-----------------------|
|              |                                 | -SS (inches)   |     | A +/- .016                 | B    | G       |                       |
| SL8-PD       | 0.500                           | 172            | 154 | 2.00                       | 4.00 | #6-32   | 0.055                 |
| SL10-PD      | 0.625                           | 184            | 154 | 2.00                       | 4.00 | #8-32   | 0.086                 |
| SL12-PD      | 0.750                           | 184            | 154 | 3.00                       | 6.00 | #10-32  | 0.125                 |
| SL16-PD      | 1.000                           | 184            | 154 | 3.00                       | 6.00 | 1/4-20  | 0.222                 |
| SL20-PD      | 1.250                           | 184            | 154 | 3.00                       | 6.00 | 5/16-18 | 0.348                 |
| SL24-PD      | 1.500                           | 184            | 154 | 4.00                       | 8.00 | 3/8-16  | 0.500                 |
| SL32-PD      | 2.000                           | 184            | 154 | 4.00                       | 8.00 | 1/2-13  | 0.890                 |

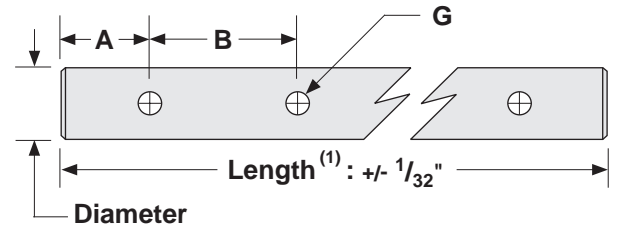

### Footnotes:

(1) Length tolerance for 2" diameter shafting is +/- 1/16 inches. Tighter tolerance available. Contact the factory.





**SM 12 - CR x 105.375**

**Shafting** \_\_\_\_\_

**SM** - Metric diameter

**Shaft Diameter** \_\_\_\_\_

**8** - 8 mm diameter  
**10** - 10 mm diameter  
**12** - 12 mm diameter  
**16** - 16 mm diameter  
**20** - 20 mm diameter  
**25** - 25 mm diameter  
**30** - 30 mm diameter  
**40** - 40 mm diameter  
**50** - 50 mm diameter

**Shaft Material** \_\_\_\_\_

- 1060 Steel  
**CR** - Chrome Plated 1060 Steel

**Overall Length** \_\_\_\_\_

**xxx.xxx** - inches for all series

## Specifications: **SM** Metric Precision Shafting

|                           |  |                           |                               |
|---------------------------|--|---------------------------|-------------------------------|
| <b>Shaft Straightness</b> | 0,0254/0,0508 mm/300 mm - cumulative   |                           |                               |
| <b>Shaft Type</b>         | 1060 Steel   |                           |                               |
| <b>Shaft Roundness</b>    | 0,0020 mm  |                           |                               |
| <b>Shaft Chamfer</b>      | For 8 - 20 mm dia. : 0,762 mm x 45°, For 25 - 50 mm dia. : 1,524 mm inch x 45° |                           |                               |
| <b>Surface Finish</b>     | 8 - 12 R <sub>a</sub> microinch  |                           |                               |
| <b>Diameter Tolerance</b> | <b>Nominal Shaft Diameter</b>  | <b>Diameter Tolerance</b> | <b>Minimum Hardness Depth</b> |
| <b>Hardness Depth</b>     | (mm)   | (mm)                      | (mm)                          |
|                           | 8  | 8,00 / 7,99               | 1,02                          |
|                           | 10   | 10,00 / 9,99              | 1,02                          |
|                           | 12   | 12,00 / 11,99             | 1,52                          |
|                           | 16   | 16,00 / 15,99             | 1,52                          |
|                           | 20   | 20,00 / 19,99             | 1,52                          |
|                           | 25   | 25,00 / 24,99             | 2,03                          |
|                           | 30   | 30,00 / 29,99             | 2,03                          |
|                           | 40   | 40,00 / 39,99             | 2,03                          |
|                           | 50   | 50,00 / 49,98             | 2,54                          |

## Dimensions & Specifications: **SM** Metric Precision Shafting

| Model Number | Nominal Shaft Diameter | Maximum Length | Shaft Weight |
|--------------|------------------------|----------------|--------------|
|              | (mm)                   | inches (mm)    | (lbs/in)     |
| <b>SM8</b>   | 8                      | 172 (4368,8)   | 0.022        |
| <b>SM10</b>  | 10                     | 172 (4368,8)   | 0.038        |
| <b>SM12</b>  | 12                     | 184 (4673,6)   | 0.050        |
| <b>SM16</b>  | 16                     | 184 (4673,6)   | 0.088        |
| <b>SM20</b>  | 20                     | 184 (4673,6)   | 0.138        |
| <b>SM25</b>  | 25                     | 184 (4673,6)   | 0.216        |
| <b>SM30</b>  | 30                     | 184 (4673,6)   | 0.311        |
| <b>SM40</b>  | 40                     | 184 (4673,6)   | 0.553        |
| <b>SM50</b>  | 50                     | 184 (4673,6)   | 0.864        |

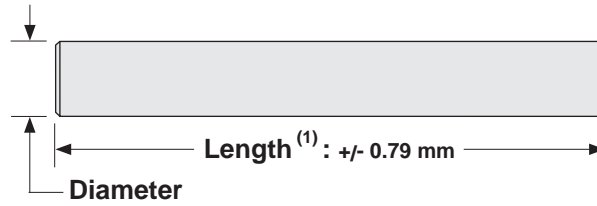

(1) Tighter tolerance available. Contact the factory.

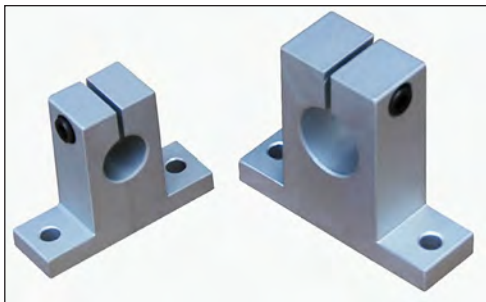

**ES 10 - A**

End Support Block \_\_\_\_\_

Shaft Diameter \_\_\_\_\_

- 8** - 0.500 inch diameter
- 12** - 0.750 inch diameter
- 16** - 1.000 inch diameter
- 20** - 1.250 inch diameter
- 24** - 1.500 inch diameter
- 32** - 2.000 inch diameter

Support Material \_\_\_\_\_

- A** - Aluminum

## Dimensions & Specifications: **ES-A** End Shaft Support Block

| Model Number  | Nominal Shaft Diameter (inches) | Dimensions (inches) |       |       |      |               |       |       |      |           | Support Weight (lbs) |
|---------------|---------------------------------|---------------------|-------|-------|------|---------------|-------|-------|------|-----------|----------------------|
|               |                                 | A<br>+/- .001       | B     | C     | D    | E<br>+/- .010 | F     | H     | M    |           |                      |
|               |                                 |                     |       |       |      |               |       |       | hole | bolt size |                      |
| <b>ES8-A</b>  | 0.500                           | 1.000               | 2.000 | 0.875 | .250 | 1.500         | 0.625 | 1.625 | .188 | #8        | .08                  |
| <b>ES12-A</b> | 0.750                           | 1.250               | 2.500 | 1.250 | .313 | 2.000         | 0.750 | 2.063 | .218 | #10       | .16                  |
| <b>ES16-A</b> | 1.000                           | 1.500               | 3.063 | 1.500 | .375 | 2.500         | 1.000 | 2.500 | .281 | 1/4       | .30                  |
| <b>ES20-A</b> | 1.250                           | 1.750               | 3.750 | 2.000 | .438 | 3.000         | 1.125 | 3.000 | .346 | 5/16      | .53                  |
| <b>ES24-A</b> | 1.500                           | 2.000               | 4.375 | 2.250 | .500 | 3.500         | 1.250 | 3.437 | .346 | 5/16      | .73                  |
| <b>ES32-A</b> | 2.000                           | 2.500               | 5.500 | 3.000 | .625 | 4.500         | 1.500 | 4.500 | .406 | 3/8       | 1.40                 |

Material: 6061-T6 aluminum  
Finish: natural finish

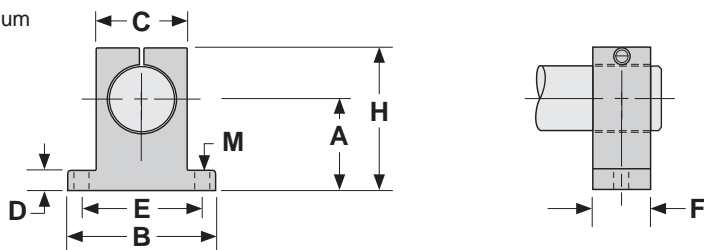

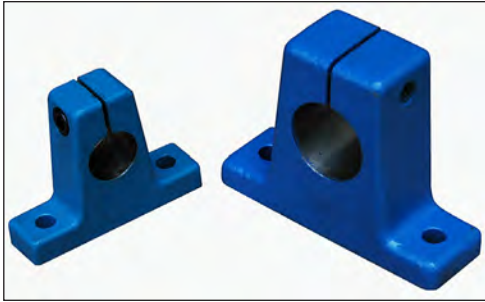

**ES 10 - S**

End Support Block \_\_\_\_\_

Shaft Diameter \_\_\_\_\_

- 8** - 0.500 inch diameter
- 10** - 0.625 inch diameter
- 12** - 0.750 inch diameter
- 16** - 1.000 inch diameter
- 20** - 1.250 inch diameter
- 24** - 1.500 inch diameter
- 32** - 2.000 inch diameter

Support Material \_\_\_\_\_

**S** - Steel

## Dimensions & Specifications: **ES-S** End Shaft Support Block

| Model Number  | Nominal Shaft Diameter (inches) | Dimensions (inches) |       |       |      |               |       |       |      |           | Support Weight (lbs) |
|---------------|---------------------------------|---------------------|-------|-------|------|---------------|-------|-------|------|-----------|----------------------|
|               |                                 | A<br>+/- .001       | B     | C     | D    | E<br>+/- .010 | F     | H     | M    |           |                      |
|               |                                 |                     |       |       |      |               |       |       | hole | bolt size |                      |
| <b>ES8-S</b>  | 0.500                           | 1.000               | 2.000 | 0.750 | .250 | 1.500         | 0.625 | 1.625 | .218 | #10       | .28                  |
| <b>ES10-S</b> | 0.625                           | 1.000               | 2.500 | 0.875 | .312 | 1.875         | 0.750 | 1.750 | .218 | #10       | .36                  |
| <b>ES12-S</b> | 0.750                           | 1.250               | 2.750 | 1.000 | .375 | 2.000         | 0.750 | 2.125 | .281 | 1/4       | .53                  |
| <b>ES16-S</b> | 1.000                           | 1.500               | 3.312 | 1.375 | .375 | 2.500         | 1.000 | 2.625 | .281 | 1/4       | 1.00                 |
| <b>ES20-S</b> | 1.250                           | 1.750               | 4.000 | 1.750 | .438 | 3.000         | 1.250 | 3.000 | .343 | 5/16      | 2.10                 |
| <b>ES24-S</b> | 1.500                           | 2.000               | 4.750 | 2.000 | .500 | 3.500         | 1.250 | 3.500 | .343 | 5/16      | 2.80                 |
| <b>ES32-S</b> | 2.000                           | 2.500               | 6.000 | 2.625 | .625 | 4.500         | 1.500 | 4.500 | .406 | 3/8       | 5.10                 |

Material: C1045 steel  
Finish: blue enamel

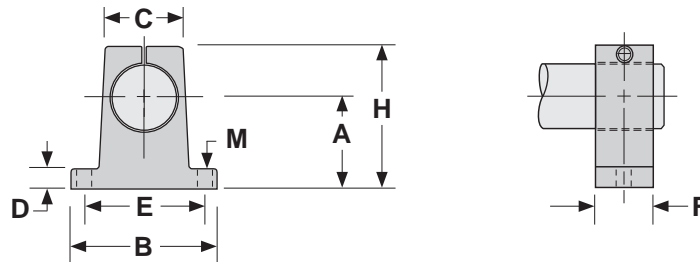

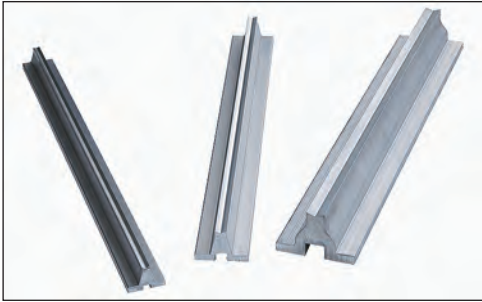

**ARS 10 - PD - 24**

**Aluminum Rail Support**

**Shaft Diameter Supported**

- 8** - 0.500 inch diameter
- 10** - 0.625 inch diameter
- 12** - 0.750 inch diameter
- 16** - 1.000 inch diameter
- 20** - 1.250 inch diameter
- 24** - 1.500 inch diameter
- 32** - 2.000 inch diameter

**Pre-Drilled**

- No mounting hole pattern
- PD** - pre-drilled hole pattern

**Support length**

- 24** - 24 inch length

### Dimensions & Specifications: **ARS-PD** Shaft Support

| Model Number<br>Without Holes | Model Number<br>With Pre-drilled Holes | Nominal Shaft Diameter (inches) | Dimensions (inches) |       |      |      |               |           |                |      |      |      | Support Weight (lbs/in) |
|-------------------------------|--|---------------------------------|---------------------|-------|------|------|---------------|-----------|----------------|------|------|------|-------------------------|
|                               |  |                                 | A<br>+/- .002       | B     | C    | D    | E<br>+/- .010 | F<br>hole | G<br>bolt size | H    | I    |      |                         |
| ARS8                          | ARS8-PD                                | 0.500                           | 1.125               | 1.500 | .250 | .187 | 1.000         | .169      | #6-32 x 0.87   | 2.00 | 4.00 | .050 |                         |
| ARS10                         | ARS10-PD                               | 0.625                           | 1.125               | 1.625 | .312 | .250 | 1.125         | .193      | #8-32 x 0.87   | 2.00 | 4.00 | .063 |                         |
| ARS12                         | ARS12-PD                               | 0.750                           | 1.500               | 1.750 | .375 | .250 | 1.250         | .221      | #10-32 x 1.25  | 3.00 | 6.00 | .083 |                         |
| ARS16                         | ARS16-PD                               | 1.000                           | 1.750               | 2.125 | .500 | .250 | 1.500         | .281      | 1/4-20 x 1.50  | 3.00 | 6.00 | .108 |                         |
| ARS20                         | ARS20-PD                               | 1.250                           | 2.125               | 2.500 | .562 | .312 | 1.875         | .343      | 5/16-18 x 1.75 | 3.00 | 6.00 | .146 |                         |
| ARS24                         | ARS24-PD                               | 1.500                           | 2.500               | 3.000 | .687 | .375 | 2.250         | .406      | 3/8-16 x 2.00  | 4.00 | 8.00 | .213 |                         |
| ARS32                         | ARS32-PD                               | 2.000                           | 3.250               | 3.750 | .875 | .500 | 2.750         | .531      | 1/2-13 x 3.25  | 4.00 | 8.00 | .342 |                         |

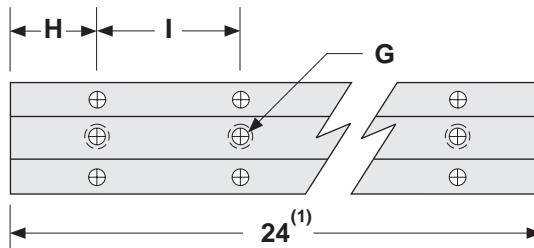
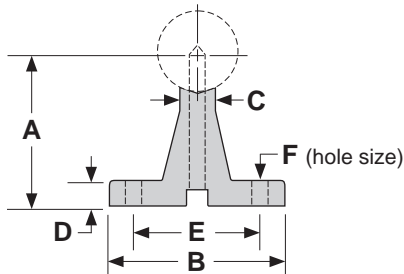

Material: 6061-T6 aluminum  
Finish: natural finish

Shorter lengths available. Contact the factory.



**LSRS 10 - PD - 48**

**Low Profile Steel Rail Support**

**Shaft Diameter Supported**

- 8** - 0.500 inch diameter
- 10** - 0.625 inch diameter
- 12** - 0.750 inch diameter
- 16** - 1.000 inch diameter
- 20** - 1.250 inch diameter
- 24** - 1.500 inch diameter
- 32** - 2.000 inch diameter

**Pre-Drilled**

- No mounting hole pattern
- PD** - pre-drilled hole pattern

**Support length**

- 48** - 48 inch length

## Dimensions & Specifications: LRS-PD Shaft Support

| Model Number  |                        | Nominal Shaft Diameter (inches) | Dimensions (inches) |      |      |      |           |      |      | Support Weight (lbs/in) |
|---------------|------------------------|---------------------------------|---------------------|------|------|------|-----------|------|------|-------------------------|
| Without Holes | With Pre-drilled Holes |                                 | A<br>+/- .002       | B    | C    | G    |           | H    | I    |                         |
|               |                        |                                 |                     |      |      | hole | bolt size |      |      |                         |
| LSRS8         | LSRS8-PD               | 0.500                           | 0.562               | 0.37 | .341 | .169 | #6-32     | 2.00 | 4.00 | .028                    |
| LSRS10        | LSRS10-PD              | 0.625                           | 0.687               | 0.45 | .412 | .193 | #8-32     | 2.00 | 4.00 | .041                    |
| LSRS12        | LSRS12-PD              | 0.750                           | 0.750               | 0.51 | .420 | .221 | #10-32    | 3.00 | 6.00 | .047                    |
| LSRS16        | LSRS16-PD              | 1.000                           | 1.000               | 0.69 | .560 | .281 | 1/4-20    | 3.00 | 6.00 | .089                    |
| LSRS20        | LSRS20-PD              | 1.250                           | 1.187               | 0.78 | .626 | .343 | 5/16-18   | 3.00 | 6.00 | .106                    |
| LSRS24        | LSRS24-PD              | 1.500                           | 1.375               | 0.93 | .703 | .406 | 3/8-16    | 4.00 | 8.00 | .140                    |
| LSRS32        | LSRS32-PD              | 2.000                           | 1.750               | 1.18 | .845 | .531 | 1/2-13    | 4.00 | 8.00 | .230                    |

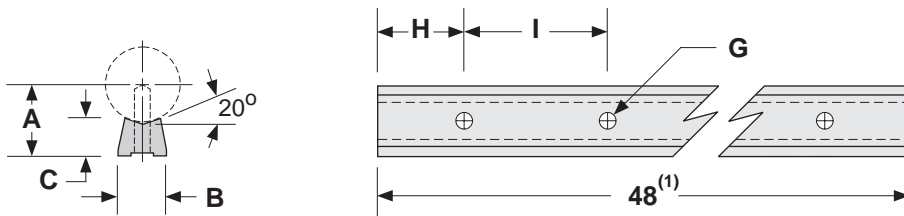

Material: AISI C-1018 steel  
Finish: natural finish

Shorter lengths available. Contact the factory.

# Notes

---



**TRSA** **12** - **6** - **SS** - **E4**

**Assembly Type** \_\_\_\_\_

**SA** - Single rail shaft assembly

**TRSA** - *TWIN RAIL*® shaft assembly

**Shaft Diameter** \_\_\_\_\_

**8** - 0.500 inch diameter

**10** - 0.625 inch diameter

**12** - 0.750 inch diameter

**16** - 1.000 inch diameter

**20** - 1.250 inch diameter

**24** - 1.500 inch diameter

**32** - 2.000 inch diameter

**Overall Length** \_\_\_\_\_

**xxx** - inches

**Shaft Material** \_\_\_\_\_

- 1060 Steel

**SS** - 440C Stainless Steel

**CR** - Chrome Plated 1060 Steel

**End Stops** \_\_\_\_\_

- No end stops

**E1** - One end stop

**E2** - Two end stops

**E3** - Three end stops

**E4** - Four end stops

### Specifications: SA & TRSA Shaft Assemblies

|                                      |  |                                 |                               |
|--------------------------------------|--|---------------------------------|-------------------------------|
| <b>Support Type &amp; Finish</b>     | Precision Machined 6061-T6 Aluminum, Black Anodized                                      |                                 |                               |
| <b>Shaft Straightness</b>            | 0.001/0.002 in/ft, cumulative  |                                 |                               |
| <b>Shaft Parallelism (TRSA only)</b> | +/- 0.002 in overall   |                                 |                               |
| <b>Shaft Type</b>                    | SL - 1060 Steel or 440C Stainless steel  |                                 |                               |
| <b>Shaft Roundness</b>               | 0.000080 inches  |                                 |                               |
| <b>Shaft Chamfer</b>                 | For 0.50 - 0.75 inch dia. : 0.03 inch x 45°, For 1.00 - 2.00 inch dia. : 0.06 inch x 45° |                                 |                               |
| <b>Surface Finish</b>                | 8 - 12 R <sub>a</sub> microinch  |                                 |                               |
| <b>Diameter Tolerance</b>            | <b>Nominal Shaft Diameter</b>  | <b>Shaft Diameter Tolerance</b> | <b>Minimum Hardness Depth</b> |
| <b>Hardness Depth</b>                | (inches)   | (inches)                        | (inches)                      |
|                                      | 0.500  | .4995 / .4990                   | 0.040                         |
|                                      | 0.625  | .6245 / .6240                   | 0.040                         |
|                                      | 0.750  | .7495 / .7490                   | 0.060                         |
|                                      | 1.000  | .9995 / .9990                   | 0.080                         |
|                                      | 1.250  | 1.2495 / 1.2490                 | 0.080                         |
|                                      | 1.500  | 1.4994 / 1.4989                 | 0.080                         |
|                                      | 2.000  | 1.9994 / 1.9987                 | 0.100                         |

Sold & Serviced By:

**ELECTROMATE**

Toll Free Phone (877) SERV098

Toll Free Fax (877) SERV099

www.electromate.com

sales@electromate.com



## Dimensions & Specifications: SA Shaft Assembly

| Model Number           | Nominal Shaft Diameter (inches) | Overall Length (inches) | Dimensions (inches) |       |      |      |               |           |                | Assembly Weight (lbs) |
|------------------------|---------------------------------|-------------------------|---------------------|-------|------|------|---------------|-----------|----------------|-----------------------|
|                        |                                 |                         | A<br>+/- .002       | B     | C    | D    | E<br>+/- .010 | F<br>hole | G<br>bolt size |                       |
| SA8-6                  | 0.500                           | 6                       | 1.125               | 1.500 | .250 | .187 | 1.000         | .169      | #6-32          | 0.5                   |
| SA10-6                 | 0.625                           | 6                       | 1.125               | 1.625 | .312 | .250 | 1.125         | .193      | #8-32          | 0.8                   |
| SA12-6                 | 0.750                           | 6                       | 1.500               | 1.750 | .375 | .250 | 1.250         | .221      | #10-32         | 1.0                   |
| SA16-6                 | 1.000                           | 6                       | 1.750               | 2.125 | .500 | .250 | 1.500         | .281      | 1/4-20         | 1.7                   |
| SA20-6 <sup>(1)</sup>  | 1.250                           | 6                       | 2.125               | 2.500 | .562 | .312 | 1.875         | .281      | 1/4-20         | 2.7                   |
| SA24-6 <sup>(1)</sup>  | 1.500                           | 6                       | 2.500               | 3.000 | .687 | .375 | 2.250         | .343      | 5/16-18        | 3.7                   |
| SA32-6 <sup>(1)</sup>  | 2.000                           | 6                       | 3.250               | 3.750 | .875 | .500 | 2.750         | .406      | 3/8-16         | 6.4                   |
| SA8-12                 | 0.500                           | 12                      | 1.125               | 1.500 | .250 | .187 | 1.000         | .169      | #6-32          | 0.9                   |
| SA10-12                | 0.625                           | 12                      | 1.125               | 1.625 | .312 | .250 | 1.125         | .193      | #8-32          | 1.5                   |
| SA12-12                | 0.750                           | 12                      | 1.500               | 1.750 | .375 | .250 | 1.250         | .221      | #10-32         | 2.0                   |
| SA16-12                | 1.000                           | 12                      | 1.750               | 2.125 | .500 | .250 | 1.500         | .281      | 1/4-20         | 3.4                   |
| SA20-12                | 1.250                           | 12                      | 2.125               | 2.500 | .562 | .312 | 1.875         | .281      | 1/4-20         | 5.3                   |
| SA24-12                | 1.500                           | 12                      | 2.500               | 3.000 | .687 | .375 | 2.250         | .343      | 5/16-18        | 7.3                   |
| SA32-12 <sup>(1)</sup> | 2.000                           | 12                      | 3.250               | 3.750 | .875 | .500 | 2.750         | .406      | 3/8-16         | 12.8                  |
| SA8-18                 | 0.500                           | 18                      | 1.125               | 1.500 | .250 | .187 | 1.000         | .169      | #6-32          | 1.4                   |
| SA10-18                | 0.625                           | 18                      | 1.125               | 1.625 | .312 | .250 | 1.125         | .193      | #8-32          | 2.2                   |
| SA12-18                | 0.750                           | 18                      | 1.500               | 1.750 | .375 | .250 | 1.250         | .221      | #10-32         | 3.0                   |
| SA16-18                | 1.000                           | 18                      | 1.750               | 2.125 | .500 | .250 | 1.500         | .281      | 1/4-20         | 5.1                   |
| SA20-18                | 1.250                           | 18                      | 2.125               | 2.500 | .562 | .312 | 1.875         | .281      | 1/4-20         | 7.9                   |
| SA24-18                | 1.500                           | 18                      | 2.500               | 3.000 | .687 | .375 | 2.250         | .343      | 5/16-18        | 11.0                  |
| SA32-18 <sup>(1)</sup> | 2.000                           | 18                      | 3.250               | 3.750 | .875 | .500 | 2.750         | .406      | 3/8-16         | 19.2                  |
| SA8-24                 | 0.500                           | 24                      | 1.125               | 1.500 | .250 | .187 | 1.000         | .169      | #6-32          | 1.8                   |
| SA10-24                | 0.625                           | 24                      | 1.125               | 1.625 | .312 | .250 | 1.125         | .193      | #8-32          | 2.9                   |
| SA12-24                | 0.750                           | 24                      | 1.500               | 1.750 | .375 | .250 | 1.250         | .221      | #10-32         | 4.0                   |
| SA16-24                | 1.000                           | 24                      | 1.750               | 2.125 | .500 | .250 | 1.500         | .281      | 1/4-20         | 6.8                   |
| SA20-24                | 1.250                           | 24                      | 2.125               | 2.500 | .562 | .312 | 1.875         | .281      | 1/4-20         | 10.5                  |
| SA24-24                | 1.500                           | 24                      | 2.500               | 3.000 | .687 | .375 | 2.250         | .343      | 5/16-18        | 14.6                  |
| SA32-24                | 2.000                           | 24                      | 3.250               | 3.750 | .875 | .500 | 2.750         | .406      | 3/8-16         | 25.6                  |
| SA8-30                 | 0.500                           | 30                      | 1.125               | 1.500 | .250 | .187 | 1.000         | .169      | #6-32          | 2.3                   |
| SA10-30                | 0.625                           | 30                      | 1.125               | 1.625 | .312 | .250 | 1.125         | .193      | #8-32          | 3.6                   |
| SA12-30                | 0.750                           | 30                      | 1.500               | 1.750 | .375 | .250 | 1.250         | .221      | #10-32         | 5.0                   |
| SA16-30                | 1.000                           | 30                      | 1.750               | 2.125 | .500 | .250 | 1.500         | .281      | 1/4-20         | 8.4                   |
| SA20-30                | 1.250                           | 30                      | 2.125               | 2.500 | .562 | .312 | 1.875         | .281      | 1/4-20         | 13.1                  |
| SA24-30                | 1.500                           | 30                      | 2.500               | 3.000 | .687 | .375 | 2.250         | .343      | 5/16-18        | 18.3                  |
| SA32-30                | 2.000                           | 30                      | 3.250               | 3.750 | .875 | .500 | 2.750         | .406      | 3/8-16         | 32.0                  |

### Footnotes:

(1) Not a stock item, but available upon request.

## Dimensions

(inches)

Sold & Serviced By:  
  
 Toll Free Phone (877) SERV098  
 Toll Free Fax (877) SERV099  
[www.electromate.com](http://www.electromate.com)  
[sales@electromate.com](mailto:sales@electromate.com)

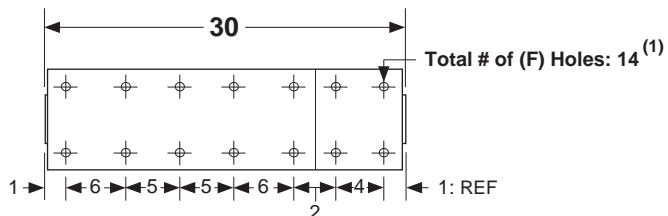
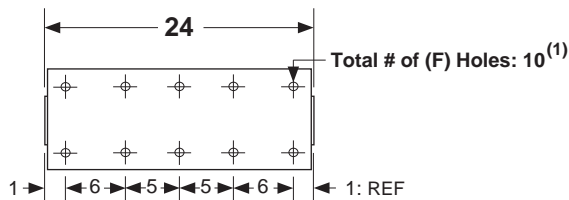
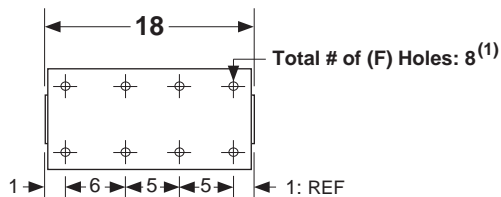
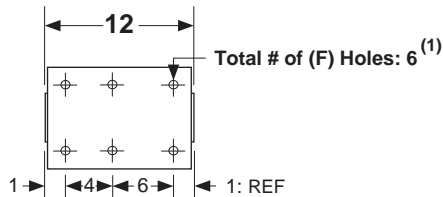
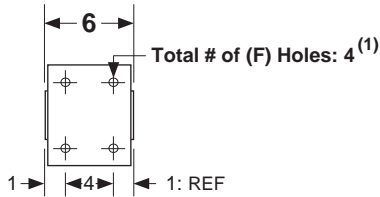
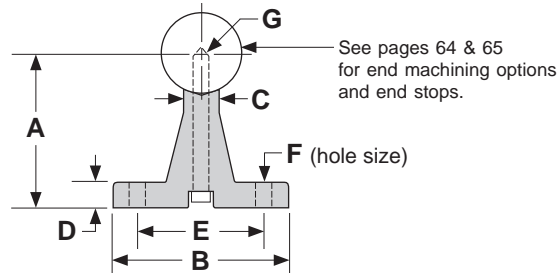

## Footnotes:

(1) Shaft supports come in 6, 12, 18 and 24 inch segments. The mounting hole location linear tolerance is +/- .010 inches noncumulative per segment. These supports are not one piece for lengths over 24 inches. The mounting hole linear tolerance is +/- .015 inches cumulative from one support segment to the next.

## Dimensions & Specifications: SA Shaft Assembly

| Model Number | Nominal Shaft Diameter (inches) | Overall Length (inches) | Dimensions (inches) |       |      |      |               |           |                | Assembly Weight (lbs) |
|--------------|---------------------------------|-------------------------|---------------------|-------|------|------|---------------|-----------|----------------|-----------------------|
|              |                                 |                         | A<br>+/- .002       | B     | C    | D    | E<br>+/- .010 | F<br>hole | G<br>bolt size |                       |
| SA8-36       | 0.500                           | 36                      | 1.125               | 1.500 | .250 | .187 | 1.000         | .169      | #6-32          | 2.7                   |
| SA10-36      | 0.625                           | 36                      | 1.125               | 1.625 | .312 | .250 | 1.125         | .193      | #8-32          | 4.3                   |
| SA12-36      | 0.750                           | 36                      | 1.500               | 1.750 | .375 | .250 | 1.250         | .221      | #10-32         | 6.0                   |
| SA16-36      | 1.000                           | 36                      | 1.750               | 2.125 | .500 | .250 | 1.500         | .281      | 1/4-20         | 10.1                  |
| SA20-36      | 1.250                           | 36                      | 2.125               | 2.500 | .562 | .312 | 1.875         | .281      | 1/4-20         | 15.7                  |
| SA24-36      | 1.500                           | 36                      | 2.500               | 3.000 | .687 | .375 | 2.250         | .343      | 5/16-18        | 21.9                  |
| SA32-36      | 2.000                           | 36                      | 3.250               | 3.750 | .875 | .500 | 2.750         | .406      | 3/8-16         | 38.4                  |
| SA8-42       | 0.500                           | 42                      | 1.125               | 1.500 | .250 | .187 | 1.000         | .169      | #6-32          | 3.2                   |
| SA10-42      | 0.625                           | 42                      | 1.125               | 1.625 | .312 | .250 | 1.125         | .193      | #8-32          | 5.1                   |
| SA12-42      | 0.750                           | 42                      | 1.500               | 1.750 | .375 | .250 | 1.250         | .221      | #10-32         | 7.0                   |
| SA16-42      | 1.000                           | 42                      | 1.750               | 2.125 | .500 | .250 | 1.500         | .281      | 1/4-20         | 11.8                  |
| SA20-42      | 1.250                           | 42                      | 2.125               | 2.500 | .562 | .312 | 1.875         | .281      | 1/4-20         | 18.4                  |
| SA24-42      | 1.500                           | 42                      | 2.500               | 3.000 | .687 | .375 | 2.250         | .343      | 5/16-18        | 25.6                  |
| SA32-42      | 2.000                           | 42                      | 3.250               | 3.750 | .875 | .500 | 2.750         | .406      | 3/8-16         | 44.8                  |
| SA8-48       | 0.500                           | 48                      | 1.125               | 1.500 | .250 | .187 | 1.000         | .169      | #6-32          | 3.6                   |
| SA10-48      | 0.625                           | 48                      | 1.125               | 1.625 | .312 | .250 | 1.125         | .193      | #8-32          | 5.8                   |
| SA12-48      | 0.750                           | 48                      | 1.500               | 1.750 | .375 | .250 | 1.250         | .221      | #10-32         | 8.0                   |
| SA16-48      | 1.000                           | 48                      | 1.750               | 2.125 | .500 | .250 | 1.500         | .281      | 1/4-20         | 13.5                  |
| SA20-48      | 1.250                           | 48                      | 2.125               | 2.500 | .562 | .312 | 1.875         | .281      | 1/4-20         | 21.0                  |
| SA24-48      | 1.500                           | 48                      | 2.500               | 3.000 | .687 | .375 | 2.250         | .343      | 5/16-18        | 29.2                  |
| SA32-48      | 2.000                           | 48                      | 3.250               | 3.750 | .875 | .500 | 2.750         | .406      | 3/8-16         | 51.2                  |
| SA8-54       | 0.500                           | 54                      | 1.125               | 1.500 | .250 | .187 | 1.000         | .169      | #6-32          | 4.1                   |
| SA10-54      | 0.625                           | 54                      | 1.125               | 1.625 | .312 | .250 | 1.125         | .193      | #8-32          | 6.5                   |
| SA12-54      | 0.750                           | 54                      | 1.500               | 1.750 | .375 | .250 | 1.250         | .221      | #10-32         | 9.0                   |
| SA16-54      | 1.000                           | 54                      | 1.750               | 2.125 | .500 | .250 | 1.500         | .281      | 1/4-20         | 15.2                  |
| SA20-54      | 1.250                           | 54                      | 2.125               | 2.500 | .562 | .312 | 1.875         | .281      | 1/4-20         | 23.6                  |
| SA24-54      | 1.500                           | 54                      | 2.500               | 3.000 | .687 | .375 | 2.250         | .343      | 5/16-18        | 32.9                  |
| SA32-54      | 2.000                           | 54                      | 3.250               | 3.750 | .875 | .500 | 2.750         | .406      | 3/8-16         | 57.6                  |
| SA8-60       | 0.500                           | 60                      | 1.125               | 1.500 | .250 | .187 | 1.000         | .169      | #6-32          | 4.5                   |
| SA10-60      | 0.625                           | 60                      | 1.125               | 1.625 | .312 | .250 | 1.125         | .193      | #8-32          | 7.2                   |
| SA12-60      | 0.750                           | 60                      | 1.500               | 1.750 | .375 | .250 | 1.250         | .221      | #10-32         | 10.0                  |
| SA16-60      | 1.000                           | 60                      | 1.750               | 2.125 | .500 | .250 | 1.500         | .281      | 1/4-20         | 16.8                  |
| SA20-60      | 1.250                           | 60                      | 2.125               | 2.500 | .562 | .312 | 1.875         | .281      | 1/4-20         | 26.2                  |
| SA24-60      | 1.500                           | 60                      | 2.500               | 3.000 | .687 | .375 | 2.250         | .343      | 5/16-18        | 36.5                  |
| SA32-60      | 2.000                           | 60                      | 3.250               | 3.750 | .875 | .500 | 2.750         | .406      | 3/8-16         | 63.9                  |

Sold & Serviced By:



Toll Free Phone (877) SERV098

Toll Free Fax (877) SERV099

[www.electromate.com](http://www.electromate.com)

[sales@electromate.com](mailto:sales@electromate.com)

Specifications subject to change without notice

## Dimensions

(inches)

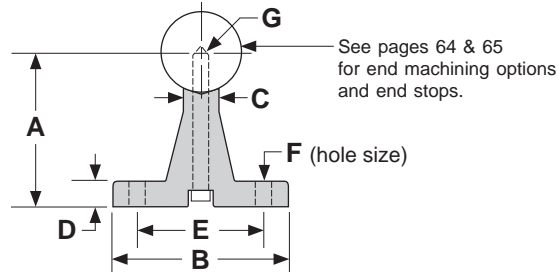

Sold & Serviced By:  
  
 Toll Free Phone (877) SERV098  
 Toll Free Fax (877) SERV099  
[www.electromate.com](http://www.electromate.com)  
[sales@electromate.com](mailto:sales@electromate.com)

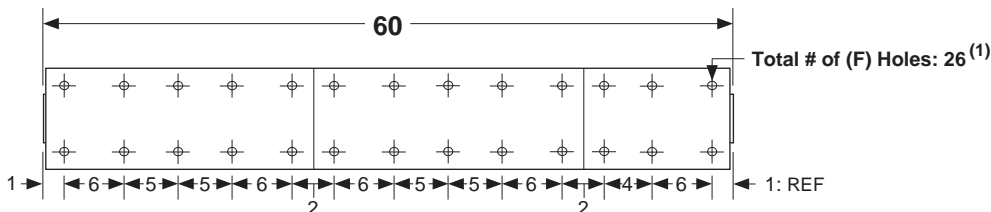
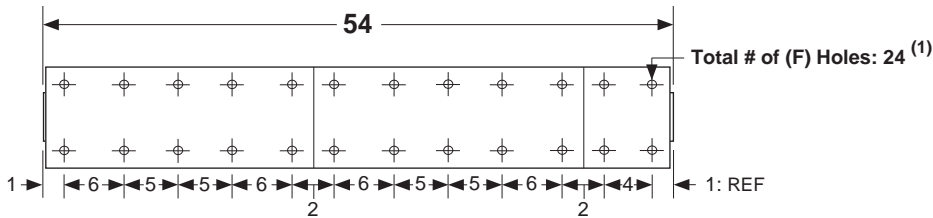
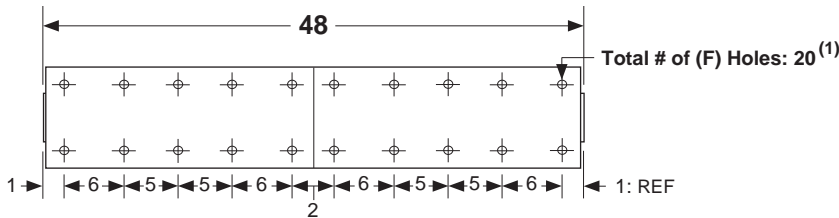
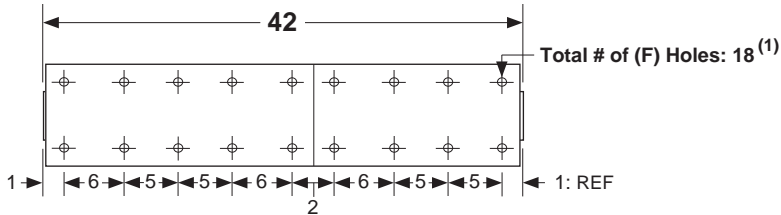
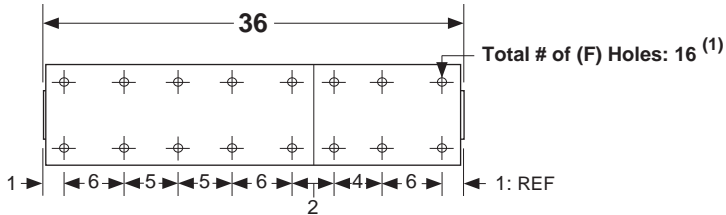

### Footnotes:

(1) Shaft supports come in 6, 12, 18 and 24 inch segments. The mounting hole location linear tolerance is +/- .010 inches noncumulative per segment. These supports are not one piece for lengths over 24 inches. The mounting hole linear tolerance is +/- .015 inches cumulative from one support segment to the next.

## Dimensions & Specifications: SA Shaft Assembly

| Model Number | Nominal Shaft Diameter (inches) | Overall Length (inches) | Dimensions (inches) |       |      |      |               |           |                | Assembly Weight (lbs) |
|--------------|---------------------------------|-------------------------|---------------------|-------|------|------|---------------|-----------|----------------|-----------------------|
|              |                                 |                         | A<br>+/- .002       | B     | C    | D    | E<br>+/- .010 | F<br>hole | G<br>bolt size |                       |
| SA8-66       | 0.500                           | 66                      | 1.125               | 1.500 | .250 | .187 | 1.000         | .169      | #6-32          | 5.0                   |
| SA10-66      | 0.625                           | 66                      | 1.125               | 1.625 | .312 | .250 | 1.125         | .193      | #8-32          | 7.9                   |
| SA12-66      | 0.750                           | 66                      | 1.500               | 1.750 | .375 | .250 | 1.250         | .221      | #10-32         | 11.0                  |
| SA16-66      | 1.000                           | 66                      | 1.750               | 2.125 | .500 | .250 | 1.500         | .281      | 1/4-20         | 18.5                  |
| SA20-66      | 1.250                           | 66                      | 2.125               | 2.500 | .562 | .312 | 1.875         | .281      | 1/4-20         | 28.8                  |
| SA24-66      | 1.500                           | 66                      | 2.500               | 3.000 | .687 | .375 | 2.250         | .343      | 5/16-18        | 40.2                  |
| SA32-66      | 2.000                           | 66                      | 3.250               | 3.750 | .875 | .500 | 2.750         | .406      | 3/8-16         | 70.3                  |
| SA8-72       | 0.500                           | 72                      | 1.125               | 1.500 | .250 | .187 | 1.000         | .169      | #6-32          | 5.4                   |
| SA10-72      | 0.625                           | 72                      | 1.125               | 1.625 | .312 | .250 | 1.125         | .193      | #8-32          | 8.6                   |
| SA12-72      | 0.750                           | 72                      | 1.500               | 1.750 | .375 | .250 | 1.250         | .221      | #10-32         | 12.0                  |
| SA16-72      | 1.000                           | 72                      | 1.750               | 2.125 | .500 | .250 | 1.500         | .281      | 1/4-20         | 20.2                  |
| SA20-72      | 1.250                           | 72                      | 2.125               | 2.500 | .562 | .312 | 1.875         | .281      | 1/4-20         | 31.4                  |
| SA24-72      | 1.500                           | 72                      | 2.500               | 3.000 | .687 | .375 | 2.250         | .343      | 5/16-18        | 43.8                  |
| SA32-72      | 2.000                           | 72                      | 3.250               | 3.750 | .875 | .500 | 2.750         | .406      | 3/8-16         | 76.7                  |
| SA8-84       | 0.500                           | 84                      | 1.125               | 1.500 | .250 | .187 | 1.000         | .169      | #6-32          | 6.3                   |
| SA10-84      | 0.625                           | 84                      | 1.125               | 1.625 | .312 | .250 | 1.125         | .193      | #8-32          | 10.0                  |
| SA12-84      | 0.750                           | 84                      | 1.500               | 1.750 | .375 | .250 | 1.250         | .221      | #10-32         | 14.0                  |
| SA16-84      | 1.000                           | 84                      | 1.750               | 2.125 | .500 | .250 | 1.500         | .281      | 1/4-20         | 23.6                  |
| SA20-84      | 1.250                           | 84                      | 2.125               | 2.500 | .562 | .312 | 1.875         | .281      | 1/4-20         | 36.6                  |
| SA24-84      | 1.500                           | 84                      | 2.500               | 3.000 | .687 | .375 | 2.250         | .343      | 5/16-18        | 51.1                  |
| SA32-84      | 2.000                           | 84                      | 3.250               | 3.750 | .875 | .500 | 2.750         | .406      | 3/8-16         | 89.5                  |
| SA8-96       | 0.500                           | 96                      | 1.125               | 1.500 | .250 | .187 | 1.000         | .169      | #6-32          | 7.2                   |
| SA10-96      | 0.625                           | 96                      | 1.125               | 1.625 | .312 | .250 | 1.125         | .193      | #8-32          | 11.5                  |
| SA12-96      | 0.750                           | 96                      | 1.500               | 1.750 | .375 | .250 | 1.250         | .221      | #10-32         | 16.0                  |
| SA16-96      | 1.000                           | 96                      | 1.750               | 2.125 | .500 | .250 | 1.500         | .281      | 1/4-20         | 26.9                  |
| SA20-96      | 1.250                           | 96                      | 2.125               | 2.500 | .562 | .312 | 1.875         | .281      | 1/4-20         | 41.9                  |
| SA24-96      | 1.500                           | 96                      | 2.500               | 3.000 | .687 | .375 | 2.250         | .343      | 5/16-18        | 58.4                  |
| SA32-96      | 2.000                           | 96                      | 3.250               | 3.750 | .875 | .500 | 2.750         | .406      | 3/8-16         | 102.3                 |
| SA8-108      | 0.500                           | 108                     | 1.125               | 1.500 | .250 | .187 | 1.000         | .169      | #6-32          | 8.1                   |
| SA10-108     | 0.625                           | 108                     | 1.125               | 1.625 | .312 | .250 | 1.125         | .193      | #8-32          | 12.9                  |
| SA12-108     | 0.750                           | 108                     | 1.500               | 1.750 | .375 | .250 | 1.250         | .221      | #10-32         | 18.0                  |
| SA16-108     | 1.000                           | 108                     | 1.750               | 2.125 | .500 | .250 | 1.500         | .281      | 1/4-20         | 30.3                  |
| SA20-108     | 1.250                           | 108                     | 2.125               | 2.500 | .562 | .312 | 1.875         | .281      | 1/4-20         | 47.1                  |
| SA24-108     | 1.500                           | 108                     | 2.500               | 3.000 | .687 | .375 | 2.250         | .343      | 5/16-18        | 65.7                  |
| SA32-108     | 2.000                           | 108                     | 3.250               | 3.750 | .875 | .500 | 2.750         | .406      | 3/8-16         | 115.1                 |

Sold & Serviced By:



Toll Free Phone (877) SERV098

Toll Free Fax (877) SERV099

[www.electromate.com](http://www.electromate.com)

[sales@electromate.com](mailto:sales@electromate.com)

Specifications subject to change without notice

## Dimensions

(inches)

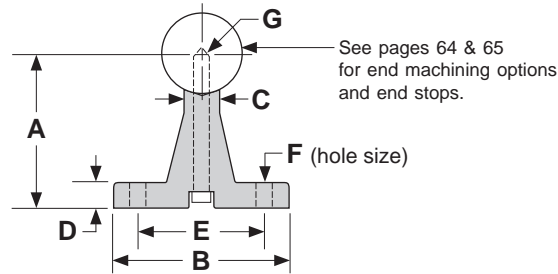

Sold & Serviced By:  
  
 Toll Free Phone (877) SERV098  
 Toll Free Fax (877) SERV099  
[www.electromate.com](http://www.electromate.com)  
[sales@electromate.com](mailto:sales@electromate.com)

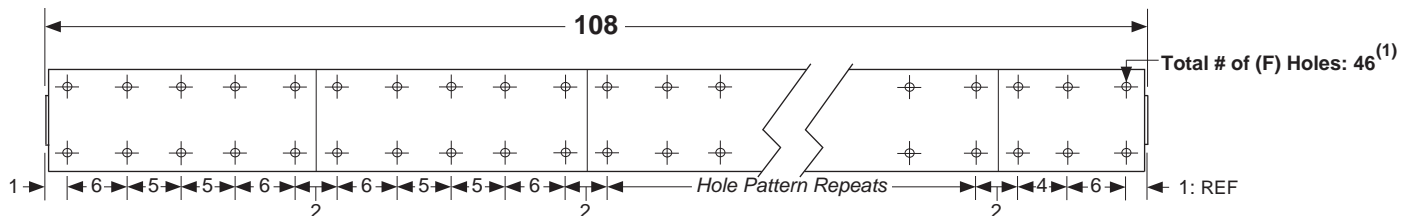
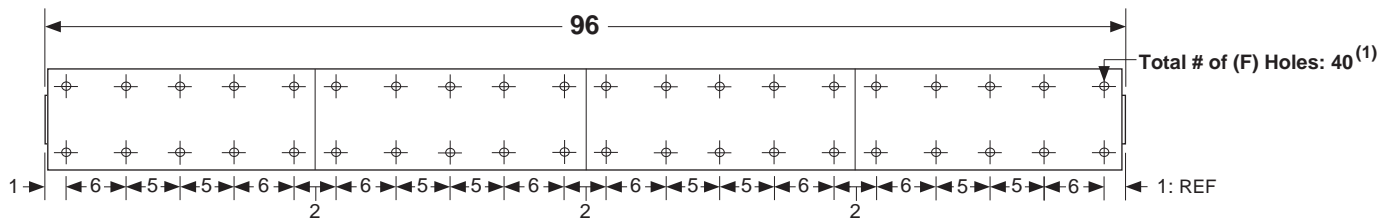
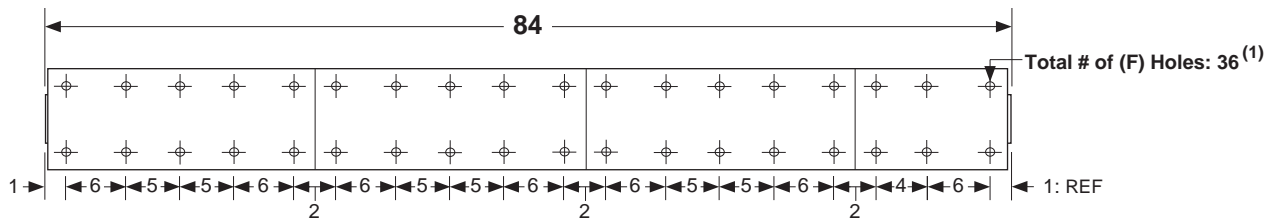
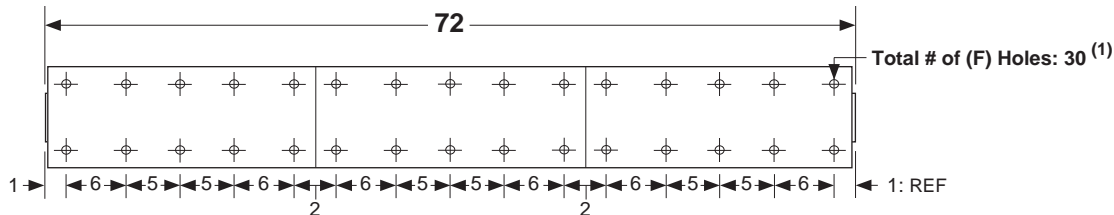
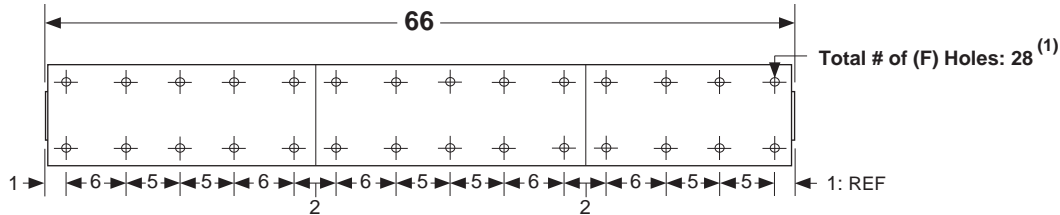

### Footnotes:

(1) Shaft supports come in 6, 12, 18 and 24 inch segments. The mounting hole location linear tolerance is +/- .010 inches noncumulative per segment. These supports are not one piece for lengths over 24 inches. The mounting hole linear tolerance is +/- .015 inches cumulative from one support segment to the next.

## Dimensions & Specifications: SA Shaft Assembly

| Model Number | Nominal Shaft Diameter (inches) | Overall Length (inches) | Dimensions (inches) |       |      |      |               |           |                | Assembly Weight (lbs) |
|--------------|---------------------------------|-------------------------|---------------------|-------|------|------|---------------|-----------|----------------|-----------------------|
|              |                                 |                         | A<br>+/- .002       | B     | C    | D    | E<br>+/- .010 | F<br>hole | G<br>bolt size |                       |
| SA8-120      | 0.500                           | 120                     | 1.125               | 1.500 | .250 | .187 | 1.000         | .169      | #6-32          | 9.0                   |
| SA10-120     | 0.625                           | 120                     | 1.125               | 1.625 | .312 | .250 | 1.125         | .193      | #8-32          | 14.3                  |
| SA12-120     | 0.750                           | 120                     | 1.500               | 1.750 | .375 | .250 | 1.250         | .221      | #10-32         | 20.0                  |
| SA16-120     | 1.000                           | 120                     | 1.750               | 2.125 | .500 | .250 | 1.500         | .281      | 1/4-20         | 33.6                  |
| SA20-120     | 1.250                           | 120                     | 2.125               | 2.500 | .562 | .312 | 1.875         | .281      | 1/4-20         | 52.3                  |
| SA24-120     | 1.500                           | 120                     | 2.500               | 3.000 | .687 | .375 | 2.250         | .343      | 5/16-18        | 73.0                  |
| SA32-120     | 2.000                           | 120                     | 3.250               | 3.750 | .875 | .500 | 2.750         | .406      | 3/8-16         | 127.8                 |
| SA8-144      | 0.500                           | 144                     | 1.125               | 1.500 | .250 | .187 | 1.000         | .169      | #6-32          | 10.8                  |
| SA10-144     | 0.625                           | 144                     | 1.125               | 1.625 | .312 | .250 | 1.125         | .193      | #8-32          | 17.2                  |
| SA12-144     | 0.750                           | 144                     | 1.500               | 1.750 | .375 | .250 | 1.250         | .221      | #10-32         | 24.0                  |
| SA16-144     | 1.000                           | 144                     | 1.750               | 2.125 | .500 | .250 | 1.500         | .281      | 1/4-20         | 40.4                  |
| SA20-144     | 1.250                           | 144                     | 2.125               | 2.500 | .562 | .312 | 1.875         | .281      | 1/4-20         | 62.8                  |
| SA24-144     | 1.500                           | 144                     | 2.500               | 3.000 | .687 | .375 | 2.250         | .343      | 5/16-18        | 87.6                  |
| SA32-144     | 2.000                           | 144                     | 3.250               | 3.750 | .875 | .500 | 2.750         | .406      | 3/8-16         | 153.4                 |
| SA12-168     | 0.750                           | 168                     | 1.500               | 1.750 | .375 | .250 | 1.250         | .221      | #10-32         | 28.0                  |
| SA16-168     | 1.000                           | 168                     | 1.750               | 2.125 | .500 | .250 | 1.500         | .281      | 1/4-20         | 47.1                  |
| SA20-168     | 1.250                           | 168                     | 2.125               | 2.500 | .562 | .312 | 1.875         | .281      | 1/4-20         | 73.3                  |
| SA24-168     | 1.500                           | 168                     | 2.500               | 3.000 | .687 | .375 | 2.250         | .343      | 5/16-18        | 102.2                 |
| SA32-168     | 2.000                           | 168                     | 3.250               | 3.750 | .875 | .500 | 2.750         | .406      | 3/8-16         | 179.0                 |
| SA12-192     | 0.750                           | 192                     | 1.500               | 1.750 | .375 | .250 | 1.250         | .221      | #10-32         | 32.0                  |
| SA16-192     | 1.000                           | 192                     | 1.750               | 2.125 | .500 | .250 | 1.500         | .281      | 1/4-20         | 53.8                  |
| SA20-192     | 1.250                           | 192                     | 2.125               | 2.500 | .562 | .312 | 1.875         | .281      | 1/4-20         | 83.7                  |
| SA24-192     | 1.500                           | 192                     | 2.500               | 3.000 | .687 | .375 | 2.250         | .343      | 5/16-18        | 116.8                 |
| SA32-192     | 2.000                           | 192                     | 3.250               | 3.750 | .875 | .500 | 2.750         | .406      | 3/8-16         | 204.5                 |

Sold & Serviced By:



Toll Free Phone (877) SERV098

Toll Free Fax (877) SERV099

[www.electromate.com](http://www.electromate.com)

[sales@electromate.com](mailto:sales@electromate.com)

Specifications subject to change without notice

## Dimensions

(inches)

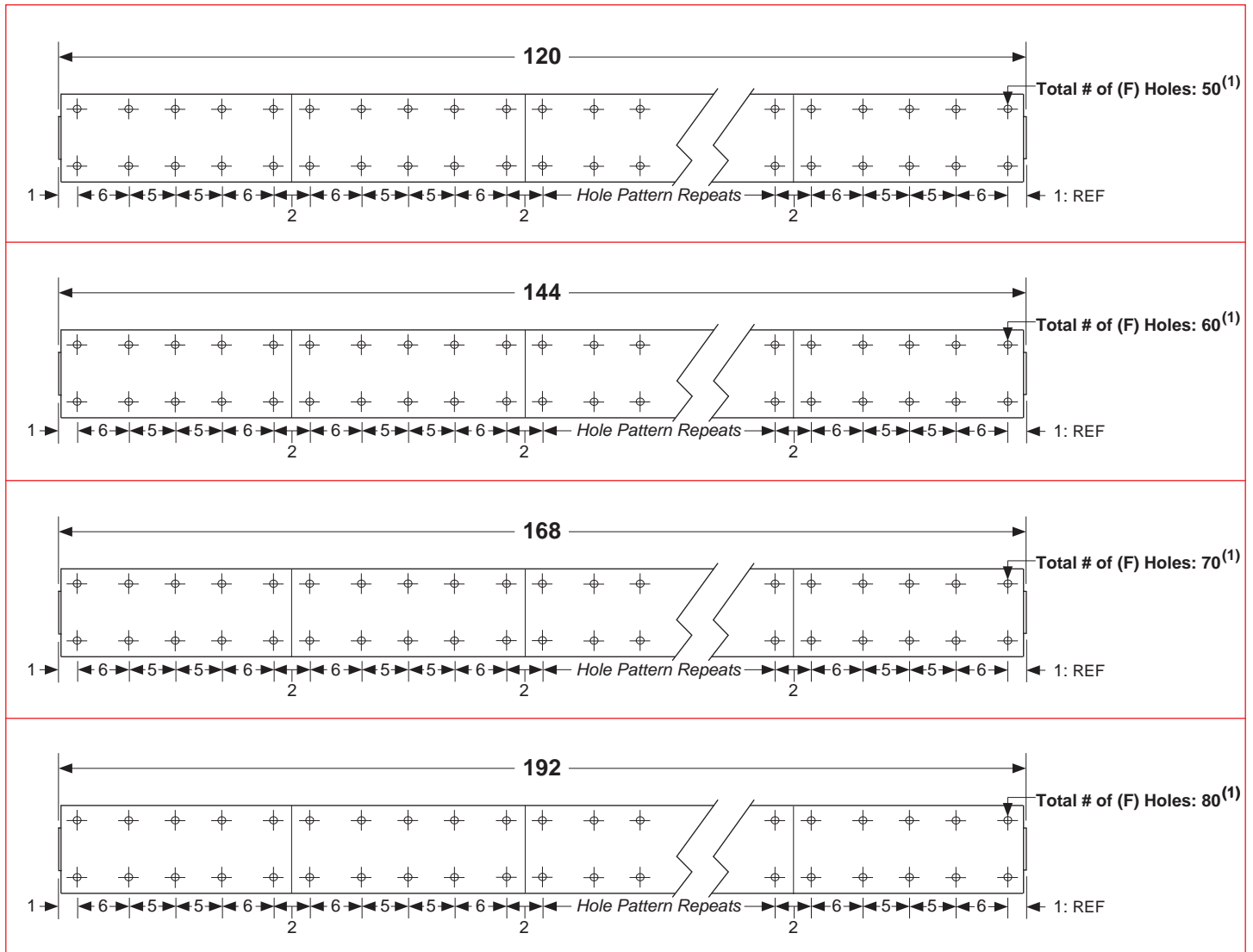
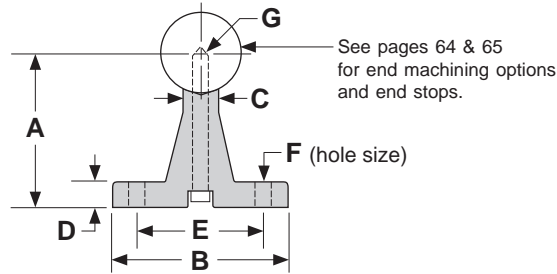

### Footnotes:

(1) Shaft supports come in 6, 12, 18 and 24 inch segments. The mounting hole location linear tolerance is +/- .010 inches noncumulative per segment. These supports are not one piece for lengths over 24 inches. The mounting hole linear tolerance is +/- .015 inches cumulative from one support segment to the next.



## Dimensions & Specifications: TRSA TWIN RAIL® Shaft Assembly

Sold & Serviced By:  
  
 Toll Free Phone (877) SERV098  
 Toll Free Fax (877) SERV099  
[www.electromate.com](http://www.electromate.com)  
[sales@electromate.com](mailto:sales@electromate.com)

| Model Number             | Nominal Shaft Diameter (inches) | Overall Length (inches) | Dimensions (inches) |               |       |       |               |      |      |      |           |                |                            | Assembly Weight (lbs) |
|--------------------------|---------------------------------|-------------------------|---------------------|---------------|-------|-------|---------------|------|------|------|-----------|----------------|----------------------------|-----------------------|
|                          |                                 |                         | A<br>+/- .002       | B<br>+/- .002 | C     | D     | E<br>+/- .010 | F    | G    | H    | J<br>hole | K<br>Bolt Size | L <sup>(2)</sup><br>Thread |                       |
| TRSA8-6                  | 0.500                           | 6                       | 1.125               | 3.000         | 3.750 | 0.875 | 2.000         | .375 | .312 | .250 | .169      | #6-32          | #10-32                     | 1.8                   |
| TRSA10-6                 | 0.625                           | 6                       | 1.125               | 3.750         | 4.625 | 1.000 | 2.625         | .437 | .312 | .312 | .193      | #8-32          | #10-32                     | 2.4                   |
| TRSA12-6                 | 0.750                           | 6                       | 1.500               | 4.500         | 5.500 | 1.125 | 3.250         | .500 | .312 | .375 | .221      | #10-32         | #10-32                     | 3.4                   |
| TRSA16-6                 | 1.000                           | 6                       | 1.750               | 5.250         | 6.375 | 1.312 | 3.750         | .562 | .312 | .500 | .281      | 1/4-20         | #10-32                     | 5.0                   |
| TRSA20-6 <sup>(1)</sup>  | 1.250                           | 6                       | 2.125               | 6.000         | 7.250 | 1.562 | 4.125         | .625 | .375 | .562 | .281      | 1/4-20         | 1/4-20                     | 7.5                   |
| TRSA24-6 <sup>(1)</sup>  | 1.500                           | 6                       | 2.500               | 6.625         | 8.125 | 1.875 | 4.375         | .750 | .437 | .687 | .343      | 5/16-18        | 5/16-18                    | 10.5                  |
| TRSA32-6 <sup>(1)</sup>  | 2.000                           | 6                       | 3.250               | 7.250         | 9.000 | 2.250 | 4.500         | .875 | .562 | .875 | .406      | 3/8-16         | 3/8-16                     | 15.7                  |
| TRSA8-12                 | 0.500                           | 12                      | 1.125               | 3.000         | 3.750 | 0.875 | 2.000         | .375 | .312 | .250 | .169      | #6-32          | #10-32                     | 3.6                   |
| TRSA10-12                | 0.625                           | 12                      | 1.125               | 3.750         | 4.625 | 1.000 | 2.625         | .437 | .312 | .312 | .193      | #8-32          | #10-32                     | 4.8                   |
| TRSA12-12                | 0.750                           | 12                      | 1.500               | 4.500         | 5.500 | 1.125 | 3.250         | .500 | .312 | .375 | .221      | #10-32         | #10-32                     | 6.8                   |
| TRSA16-12                | 1.000                           | 12                      | 1.750               | 5.250         | 6.375 | 1.312 | 3.750         | .562 | .312 | .500 | .281      | 1/4-20         | #10-32                     | 10.0                  |
| TRSA20-12                | 1.250                           | 12                      | 2.125               | 6.000         | 7.250 | 1.562 | 4.125         | .625 | .375 | .562 | .281      | 1/4-20         | 1/4-20                     | 15.0                  |
| TRSA24-12                | 1.500                           | 12                      | 2.500               | 6.625         | 8.125 | 1.875 | 4.375         | .750 | .437 | .687 | .343      | 5/16-18        | 5/16-18                    | 21.0                  |
| TRSA32-12 <sup>(1)</sup> | 2.000                           | 12                      | 3.250               | 7.250         | 9.000 | 2.250 | 4.500         | .875 | .562 | .875 | .406      | 3/8-16         | 3/8-16                     | 31.3                  |
| TRSA8-18                 | 0.500                           | 18                      | 1.125               | 3.000         | 3.750 | 0.875 | 2.000         | .375 | .312 | .250 | .169      | #6-32          | #10-32                     | 5.4                   |
| TRSA10-18                | 0.625                           | 18                      | 1.125               | 3.750         | 4.625 | 1.000 | 2.625         | .437 | .312 | .312 | .193      | #8-32          | #10-32                     | 7.2                   |
| TRSA12-18                | 0.750                           | 18                      | 1.500               | 4.500         | 5.500 | 1.125 | 3.250         | .500 | .312 | .375 | .221      | #10-32         | #10-32                     | 10.1                  |
| TRSA16-18                | 1.000                           | 18                      | 1.750               | 5.250         | 6.375 | 1.312 | 3.750         | .562 | .312 | .500 | .281      | 1/4-20         | #10-32                     | 15.0                  |
| TRSA20-18                | 1.250                           | 18                      | 2.125               | 6.000         | 7.250 | 1.562 | 4.125         | .625 | .375 | .562 | .281      | 1/4-20         | 1/4-20                     | 22.4                  |
| TRSA24-18                | 1.500                           | 18                      | 2.500               | 6.625         | 8.125 | 1.875 | 4.375         | .750 | .437 | .687 | .343      | 5/16-18        | 5/16-18                    | 31.4                  |
| TRSA32-18 <sup>(1)</sup> | 2.000                           | 18                      | 3.250               | 7.250         | 9.000 | 2.250 | 4.500         | .875 | .562 | .875 | .406      | 3/8-16         | 3/8-16                     | 46.9                  |
| TRSA8-24                 | 0.500                           | 24                      | 1.125               | 3.000         | 3.750 | 0.875 | 2.000         | .375 | .312 | .250 | .169      | #6-32          | #10-32                     | 7.2                   |
| TRSA10-24                | 0.625                           | 24                      | 1.125               | 3.750         | 4.625 | 1.000 | 2.625         | .437 | .312 | .312 | .193      | #8-32          | #10-32                     | 9.6                   |
| TRSA12-24                | 0.750                           | 24                      | 1.500               | 4.500         | 5.500 | 1.125 | 3.250         | .500 | .312 | .375 | .221      | #10-32         | #10-32                     | 13.5                  |
| TRSA16-24                | 1.000                           | 24                      | 1.750               | 5.250         | 6.375 | 1.312 | 3.750         | .562 | .312 | .500 | .281      | 1/4-20         | #10-32                     | 20.0                  |
| TRSA20-24                | 1.250                           | 24                      | 2.125               | 6.000         | 7.250 | 1.562 | 4.125         | .625 | .375 | .562 | .281      | 1/4-20         | 1/4-20                     | 29.9                  |
| TRSA24-24                | 1.500                           | 24                      | 2.500               | 6.625         | 8.125 | 1.875 | 4.375         | .750 | .437 | .687 | .343      | 5/16-18        | 5/16-18                    | 41.9                  |
| TRSA32-24                | 2.000                           | 24                      | 3.250               | 7.250         | 9.000 | 2.250 | 4.500         | .875 | .562 | .875 | .406      | 3/8-16         | 3/8-16                     | 62.5                  |
| TRSA8-30                 | 0.500                           | 30                      | 1.125               | 3.000         | 3.750 | 0.875 | 2.000         | .375 | .312 | .250 | .169      | #6-32          | #10-32                     | 9.0                   |
| TRSA10-30                | 0.625                           | 30                      | 1.125               | 3.750         | 4.625 | 1.000 | 2.625         | .437 | .312 | .312 | .193      | #8-32          | #10-32                     | 12.0                  |
| TRSA12-30                | 0.750                           | 30                      | 1.500               | 4.500         | 5.500 | 1.125 | 3.250         | .500 | .312 | .375 | .221      | #10-32         | #10-32                     | 16.8                  |
| TRSA16-30                | 1.000                           | 30                      | 1.750               | 5.250         | 6.375 | 1.312 | 3.750         | .562 | .312 | .500 | .281      | 1/4-20         | #10-32                     | 25.0                  |
| TRSA20-30                | 1.250                           | 30                      | 2.125               | 6.000         | 7.250 | 1.562 | 4.125         | .625 | .375 | .562 | .281      | 1/4-20         | 1/4-20                     | 37.3                  |
| TRSA24-30                | 1.500                           | 30                      | 2.500               | 6.625         | 8.125 | 1.875 | 4.375         | .750 | .437 | .687 | .343      | 5/16-18        | 5/16-18                    | 52.3                  |
| TRSA32-30                | 2.000                           | 30                      | 3.250               | 7.250         | 9.000 | 2.250 | 4.500         | .875 | .562 | .875 | .406      | 3/8-16         | 3/8-16                     | 78.1                  |

### Footnotes:

(1) Not a stock item, but available upon request.

(2) Two threaded leveling holes per TWIN RAIL® support segment are used for setscrew adjustment to aid in assembly leveling to the user mounting surfaces.

## Dimensions

(inches)

Sold & Serviced By:  

Toll Free Phone (877) SERV098  
 Toll Free Fax (877) SERV099  
[www.electromate.com](http://www.electromate.com)  
[sales@electromate.com](mailto:sales@electromate.com)

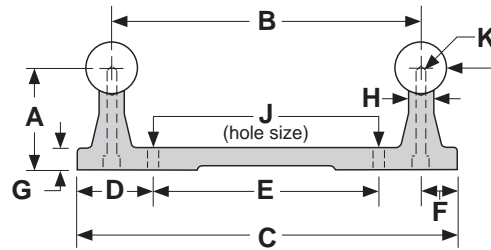

See pages 64 & 65  
 for end machining options  
 and end stops.

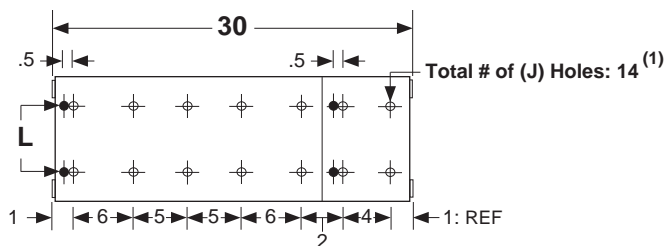
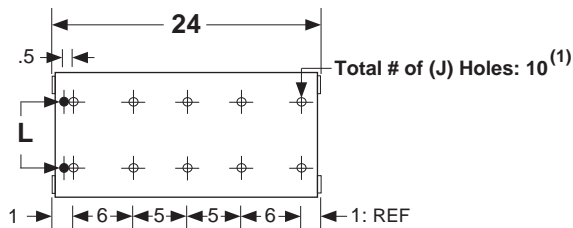
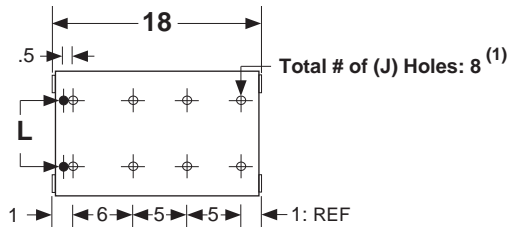
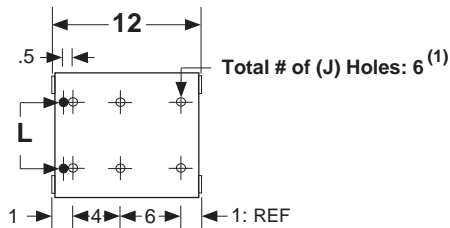
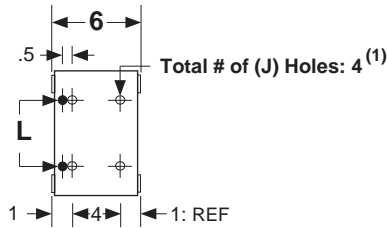

## Footnotes:

(1) *TWIN RAIL*® supports come in 6, 12, 18 and 24 inch segments. The mounting hole location linear tolerance is +/- .010 inches noncumulative per segment. The supports are not one piece for lengths over 24 inches. The mounting hole linear tolerance is +/- .015 inches cumulative from one support segment to the next.

## Dimensions & Specifications: TRSA TWIN RAIL® Shaft Assembly

Sold & Serviced By:  
  
 Toll Free Phone (877) SERV098  
 Toll Free Fax (877) SERV099  
[www.electromate.com](http://www.electromate.com)  
[sales@electromate.com](mailto:sales@electromate.com)

| Model Number | Nominal Shaft Diameter (inches) | Overall Length (inches) | Dimensions (inches) |               |       |       |               |      |      |      |           |                |                            | Assembly Weight (lbs) |
|--------------|---------------------------------|-------------------------|---------------------|---------------|-------|-------|---------------|------|------|------|-----------|----------------|----------------------------|-----------------------|
|              |                                 |                         | A<br>+/- .002       | B<br>+/- .002 | C     | D     | E<br>+/- .010 | F    | G    | H    | J<br>hole | K<br>Bolt Size | L <sup>(1)</sup><br>Thread |                       |
| TRSA8-36     | 0.500                           | 36                      | 1.125               | 3.000         | 3.750 | 0.875 | 2.000         | .375 | .312 | .250 | .169      | #6-32          | #10-32                     | 10.8                  |
| TRSA10-36    | 0.625                           | 36                      | 1.125               | 3.750         | 4.625 | 1.000 | 2.625         | .437 | .312 | .312 | .193      | #8-32          | #10-32                     | 14.4                  |
| TRSA12-36    | 0.750                           | 36                      | 1.500               | 4.500         | 5.500 | 1.125 | 3.250         | .500 | .312 | .375 | .221      | #10-32         | #10-32                     | 20.2                  |
| TRSA16-36    | 1.000                           | 36                      | 1.750               | 5.250         | 6.375 | 1.312 | 3.750         | .562 | .312 | .500 | .281      | 1/4-20         | #10-32                     | 30.0                  |
| TRSA20-36    | 1.250                           | 36                      | 2.125               | 6.000         | 7.250 | 1.562 | 4.125         | .625 | .375 | .562 | .281      | 1/4-20         | 1/4-20                     | 44.8                  |
| TRSA24-36    | 1.500                           | 36                      | 2.500               | 6.625         | 8.125 | 1.875 | 4.375         | .750 | .437 | .687 | .343      | 5/16-18        | 5/16-18                    | 62.8                  |
| TRSA32-36    | 2.000                           | 36                      | 3.250               | 7.250         | 9.000 | 2.250 | 4.500         | .875 | .562 | .875 | .406      | 3/8-16         | 3/8-16                     | 93.7                  |
| TRSA8-42     | 0.500                           | 42                      | 1.125               | 3.000         | 3.750 | 0.875 | 2.000         | .375 | .312 | .250 | .169      | #6-32          | #10-32                     | 12.6                  |
| TRSA10-42    | 0.625                           | 42                      | 1.125               | 3.750         | 4.625 | 1.000 | 2.625         | .437 | .312 | .312 | .193      | #8-32          | #10-32                     | 16.7                  |
| TRSA12-42    | 0.750                           | 42                      | 1.500               | 4.500         | 5.500 | 1.125 | 3.250         | .500 | .312 | .375 | .221      | #10-32         | #10-32                     | 23.6                  |
| TRSA16-42    | 1.000                           | 42                      | 1.750               | 5.250         | 6.375 | 1.312 | 3.750         | .562 | .312 | .500 | .281      | 1/4-20         | #10-32                     | 35.0                  |
| TRSA20-42    | 1.250                           | 42                      | 2.125               | 6.000         | 7.250 | 1.562 | 4.125         | .625 | .375 | .562 | .281      | 1/4-20         | 1/4-20                     | 52.3                  |
| TRSA24-42    | 1.500                           | 42                      | 2.500               | 6.625         | 8.125 | 1.875 | 4.375         | .750 | .437 | .687 | .343      | 5/16-18        | 5/16-18                    | 73.2                  |
| TRSA32-42    | 2.000                           | 42                      | 3.250               | 7.250         | 9.000 | 2.250 | 4.500         | .875 | .562 | .875 | .406      | 3/8-16         | 3/8-16                     | 109.3                 |
| TRSA8-48     | 0.500                           | 48                      | 1.125               | 3.000         | 3.750 | 0.875 | 2.000         | .375 | .312 | .250 | .169      | #6-32          | #10-32                     | 14.4                  |
| TRSA10-48    | 0.625                           | 48                      | 1.125               | 3.750         | 4.625 | 1.000 | 2.625         | .437 | .312 | .312 | .193      | #8-32          | #10-32                     | 19.1                  |
| TRSA12-48    | 0.750                           | 48                      | 1.500               | 4.500         | 5.500 | 1.125 | 3.250         | .500 | .312 | .375 | .221      | #10-32         | #10-32                     | 26.9                  |
| TRSA16-48    | 1.000                           | 48                      | 1.750               | 5.250         | 6.375 | 1.312 | 3.750         | .562 | .312 | .500 | .281      | 1/4-20         | #10-32                     | 40.0                  |
| TRSA20-48    | 1.250                           | 48                      | 2.125               | 6.000         | 7.250 | 1.562 | 4.125         | .625 | .375 | .562 | .281      | 1/4-20         | 1/4-20                     | 59.7                  |
| TRSA24-48    | 1.500                           | 48                      | 2.500               | 6.625         | 8.125 | 1.875 | 4.375         | .750 | .437 | .687 | .343      | 5/16-18        | 5/16-18                    | 83.7                  |
| TRSA32-48    | 2.000                           | 48                      | 3.250               | 7.250         | 9.000 | 2.250 | 4.500         | .875 | .562 | .875 | .406      | 3/8-16         | 3/8-16                     | 124.9                 |
| TRSA8-54     | 0.500                           | 54                      | 1.125               | 3.000         | 3.750 | 0.875 | 2.000         | .375 | .312 | .250 | .169      | #6-32          | #10-32                     | 16.2                  |
| TRSA10-54    | 0.625                           | 54                      | 1.125               | 3.750         | 4.625 | 1.000 | 2.625         | .437 | .312 | .312 | .193      | #8-32          | #10-32                     | 21.5                  |
| TRSA12-54    | 0.750                           | 54                      | 1.500               | 4.500         | 5.500 | 1.125 | 3.250         | .500 | .312 | .375 | .221      | #10-32         | #10-32                     | 30.3                  |
| TRSA16-54    | 1.000                           | 54                      | 1.750               | 5.250         | 6.375 | 1.312 | 3.750         | .562 | .312 | .500 | .281      | 1/4-20         | #10-32                     | 45.0                  |
| TRSA20-54    | 1.250                           | 54                      | 2.125               | 6.000         | 7.250 | 1.562 | 4.125         | .625 | .375 | .562 | .281      | 1/4-20         | 1/4-20                     | 67.2                  |
| TRSA24-54    | 1.500                           | 54                      | 2.500               | 6.625         | 8.125 | 1.875 | 4.375         | .750 | .437 | .687 | .343      | 5/16-18        | 5/16-18                    | 94.1                  |
| TRSA32-54    | 2.000                           | 54                      | 3.250               | 7.250         | 9.000 | 2.250 | 4.500         | .875 | .562 | .875 | .406      | 3/8-16         | 3/8-16                     | 140.5                 |
| TRSA8-60     | 0.500                           | 60                      | 1.125               | 3.000         | 3.750 | 0.875 | 2.000         | .375 | .312 | .250 | .169      | #6-32          | #10-32                     | 18.0                  |
| TRSA10-60    | 0.625                           | 60                      | 1.125               | 3.750         | 4.625 | 1.000 | 2.625         | .437 | .312 | .312 | .193      | #8-32          | #10-32                     | 23.9                  |
| TRSA12-60    | 0.750                           | 60                      | 1.500               | 4.500         | 5.500 | 1.125 | 3.250         | .500 | .312 | .375 | .221      | #10-32         | #10-32                     | 33.6                  |
| TRSA16-60    | 1.000                           | 60                      | 1.750               | 5.250         | 6.375 | 1.312 | 3.750         | .562 | .312 | .500 | .281      | 1/4-20         | #10-32                     | 49.9                  |
| TRSA20-60    | 1.250                           | 60                      | 2.125               | 6.000         | 7.250 | 1.562 | 4.125         | .625 | .375 | .562 | .281      | 1/4-20         | 1/4-20                     | 74.6                  |
| TRSA24-60    | 1.500                           | 60                      | 2.500               | 6.625         | 8.125 | 1.875 | 4.375         | .750 | .437 | .687 | .343      | 5/16-18        | 5/16-18                    | 104.6                 |
| TRSA32-60    | 2.000                           | 60                      | 3.250               | 7.250         | 9.000 | 2.250 | 4.500         | .875 | .562 | .875 | .406      | 3/8-16         | 3/8-16                     | 156.1                 |

### Footnotes:

(1) Two threaded leveling holes per TWIN RAIL® support segment are used for setscrew adjustment to aid in assembly leveling to the user mounting surfaces.

## Dimensions

(inches)

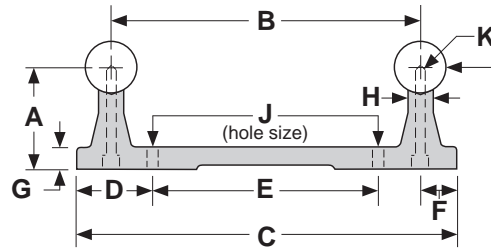

See pages 64 & 65 for end machining options and end stops.

Sold & Serviced By:  
**ELECTROMATE**  
 Toll Free Phone (877) SERV098  
 Toll Free Fax (877) SERV099  
[www.electromate.com](http://www.electromate.com)  
[sales@electromate.com](mailto:sales@electromate.com)

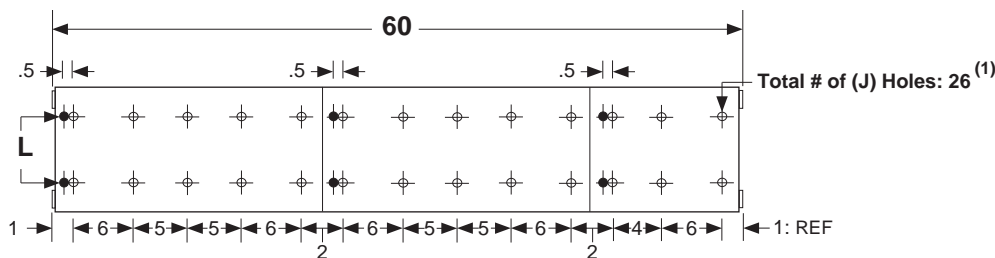
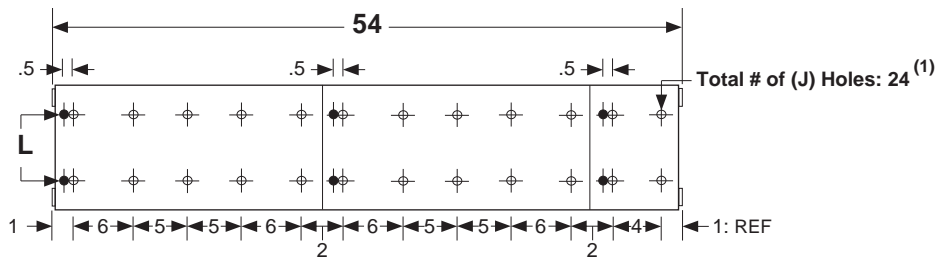
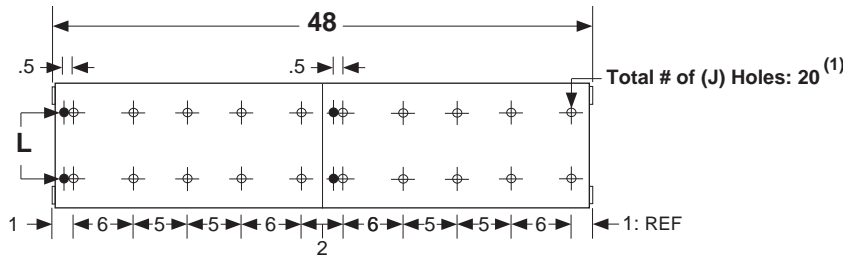
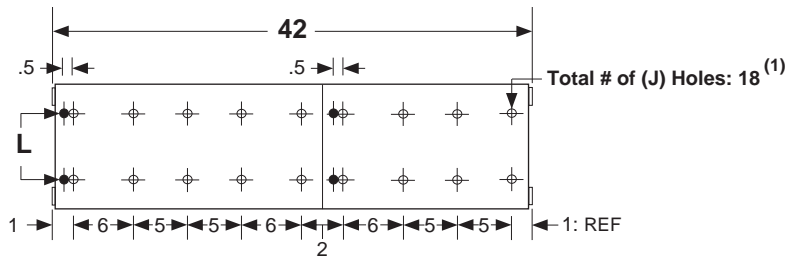
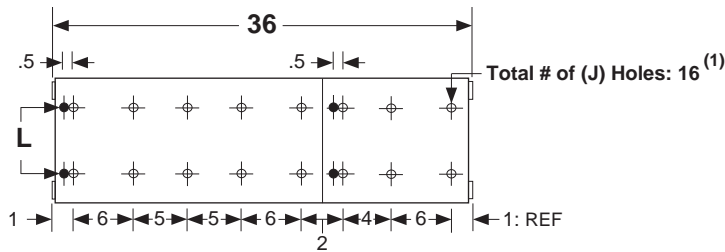

## Footnotes:

(1) *TWIN RAIL*® supports come in 6, 12, 18 and 24 inch segments. The mounting hole location linear tolerance is +/- .010 inches noncumulative per segment. The supports are not one piece for lengths over 24 inches. The mounting hole linear tolerance is +/- .015 inches cumulative from one support segment to the next.

## Dimensions & Specifications: TRSA TWIN RAIL® Shaft Assembly

Sold & Serviced By:  
  
 Toll Free Phone (877) SERV098  
 Toll Free Fax (877) SERV099  
[www.electromate.com](http://www.electromate.com)  
[sales@electromate.com](mailto:sales@electromate.com)

| Model Number | Nominal Shaft Diameter (inches) | Overall Length (inches) | Dimensions (inches) |               |       |       |               |      |      |      |           |                |                            | Assembly Weight (lbs) |
|--------------|---------------------------------|-------------------------|---------------------|---------------|-------|-------|---------------|------|------|------|-----------|----------------|----------------------------|-----------------------|
|              |                                 |                         | A<br>+/- .002       | B<br>+/- .002 | C     | D     | E<br>+/- .010 | F    | G    | H    | J<br>hole | K<br>Bolt Size | L <sup>(1)</sup><br>Thread |                       |
| TRSA8-66     | 0.500                           | 66                      | 1.125               | 3.000         | 3.750 | 0.875 | 2.000         | .375 | .312 | .250 | .169      | #6-32          | #10-32                     | 19.8                  |
| TRSA10-66    | 0.625                           | 66                      | 1.125               | 3.750         | 4.625 | 1.000 | 2.625         | .437 | .312 | .312 | .193      | #8-32          | #10-32                     | 26.3                  |
| TRSA12-66    | 0.750                           | 66                      | 1.500               | 4.500         | 5.500 | 1.125 | 3.250         | .500 | .312 | .375 | .221      | #10-32         | #10-32                     | 37.0                  |
| TRSA16-66    | 1.000                           | 66                      | 1.750               | 5.250         | 6.375 | 1.312 | 3.750         | .562 | .312 | .500 | .281      | 1/4-20         | #10-32                     | 54.9                  |
| TRSA20-66    | 1.250                           | 66                      | 2.125               | 6.000         | 7.250 | 1.562 | 4.125         | .625 | .375 | .562 | .281      | 1/4-20         | 1/4-20                     | 82.1                  |
| TRSA24-66    | 1.500                           | 66                      | 2.500               | 6.625         | 8.125 | 1.875 | 4.375         | .750 | .437 | .687 | .343      | 5/16-18        | 5/16-18                    | 115.1                 |
| TRSA32-66    | 2.000                           | 66                      | 3.250               | 7.250         | 9.000 | 2.250 | 4.500         | .875 | .562 | .875 | .406      | 3/8-16         | 3/8-16                     | 171.8                 |
| TRSA8-72     | 0.500                           | 72                      | 1.125               | 3.000         | 3.750 | 0.875 | 2.000         | .375 | .312 | .250 | .169      | #6-32          | #10-32                     | 21.6                  |
| TRSA10-72    | 0.625                           | 72                      | 1.125               | 3.750         | 4.625 | 1.000 | 2.625         | .437 | .312 | .312 | .193      | #8-32          | #10-32                     | 28.7                  |
| TRSA12-72    | 0.750                           | 72                      | 1.500               | 4.500         | 5.500 | 1.125 | 3.250         | .500 | .312 | .375 | .221      | #10-32         | #10-32                     | 40.4                  |
| TRSA16-72    | 1.000                           | 72                      | 1.750               | 5.250         | 6.375 | 1.312 | 3.750         | .562 | .312 | .500 | .281      | 1/4-20         | #10-32                     | 59.9                  |
| TRSA20-72    | 1.250                           | 72                      | 2.125               | 6.000         | 7.250 | 1.562 | 4.125         | .625 | .375 | .562 | .281      | 1/4-20         | 1/4-20                     | 89.6                  |
| TRSA24-72    | 1.500                           | 72                      | 2.500               | 6.625         | 8.125 | 1.875 | 4.375         | .750 | .437 | .687 | .343      | 5/16-18        | 5/16-18                    | 125.5                 |
| TRSA32-72    | 2.000                           | 72                      | 3.250               | 7.250         | 9.000 | 2.250 | 4.500         | .875 | .562 | .875 | .406      | 3/8-16         | 3/8-16                     | 187.4                 |
| TRSA8-84     | 0.500                           | 84                      | 1.125               | 3.000         | 3.750 | 0.875 | 2.000         | .375 | .312 | .250 | .169      | #6-32          | #10-32                     | 25.2                  |
| TRSA10-84    | 0.625                           | 84                      | 1.125               | 3.750         | 4.625 | 1.000 | 2.625         | .437 | .312 | .312 | .193      | #8-32          | #10-32                     | 33.4                  |
| TRSA12-84    | 0.750                           | 84                      | 1.500               | 4.500         | 5.500 | 1.125 | 3.250         | .500 | .312 | .375 | .221      | #10-32         | #10-32                     | 47.1                  |
| TRSA16-84    | 1.000                           | 84                      | 1.750               | 5.250         | 6.375 | 1.312 | 3.750         | .562 | .312 | .500 | .281      | 1/4-20         | #10-32                     | 69.9                  |
| TRSA20-84    | 1.250                           | 84                      | 2.125               | 6.000         | 7.250 | 1.562 | 4.125         | .625 | .375 | .562 | .281      | 1/4-20         | 1/4-20                     | 104.5                 |
| TRSA24-84    | 1.500                           | 84                      | 2.500               | 6.625         | 8.125 | 1.875 | 4.375         | .750 | .437 | .687 | .343      | 5/16-18        | 5/16-18                    | 146.4                 |
| TRSA32-84    | 2.000                           | 84                      | 3.250               | 7.250         | 9.000 | 2.250 | 4.500         | .875 | .562 | .875 | .406      | 3/8-16         | 3/8-16                     | 218.6                 |
| TRSA8-96     | 0.500                           | 96                      | 1.125               | 3.000         | 3.750 | 0.875 | 2.000         | .375 | .312 | .250 | .169      | #6-32          | #10-32                     | 28.8                  |
| TRSA10-96    | 0.625                           | 96                      | 1.125               | 3.750         | 4.625 | 1.000 | 2.625         | .437 | .312 | .312 | .193      | #8-32          | #10-32                     | 38.2                  |
| TRSA12-96    | 0.750                           | 96                      | 1.500               | 4.500         | 5.500 | 1.125 | 3.250         | .500 | .312 | .375 | .221      | #10-32         | #10-32                     | 53.8                  |
| TRSA16-96    | 1.000                           | 96                      | 1.750               | 5.250         | 6.375 | 1.312 | 3.750         | .562 | .312 | .500 | .281      | 1/4-20         | #10-32                     | 79.9                  |
| TRSA20-96    | 1.250                           | 96                      | 2.125               | 6.000         | 7.250 | 1.562 | 4.125         | .625 | .375 | .562 | .281      | 1/4-20         | 1/4-20                     | 119.4                 |
| TRSA24-96    | 1.500                           | 96                      | 2.500               | 6.625         | 8.125 | 1.875 | 4.375         | .750 | .437 | .687 | .343      | 5/16-18        | 5/16-18                    | 167.3                 |
| TRSA32-96    | 2.000                           | 96                      | 3.250               | 7.250         | 9.000 | 2.250 | 4.500         | .875 | .562 | .875 | .406      | 3/8-16         | 3/8-16                     | 249.8                 |
| TRSA8-108    | 0.500                           | 108                     | 1.125               | 3.000         | 3.750 | 0.875 | 2.000         | .375 | .312 | .250 | .169      | #6-32          | #10-32                     | 32.4                  |
| TRSA10-108   | 0.625                           | 108                     | 1.125               | 3.750         | 4.625 | 1.000 | 2.625         | .437 | .312 | .312 | .193      | #8-32          | #10-32                     | 43.0                  |
| TRSA12-108   | 0.750                           | 108                     | 1.500               | 4.500         | 5.500 | 1.125 | 3.250         | .500 | .312 | .375 | .221      | #10-32         | #10-32                     | 60.5                  |
| TRSA16-108   | 1.000                           | 108                     | 1.750               | 5.250         | 6.375 | 1.312 | 3.750         | .562 | .312 | .500 | .281      | 1/4-20         | #10-32                     | 89.9                  |
| TRSA20-108   | 1.250                           | 108                     | 2.125               | 6.000         | 7.250 | 1.562 | 4.125         | .625 | .375 | .562 | .281      | 1/4-20         | 1/4-20                     | 134.3                 |
| TRSA24-108   | 1.500                           | 108                     | 2.500               | 6.625         | 8.125 | 1.875 | 4.375         | .750 | .437 | .687 | .343      | 5/16-18        | 5/16-18                    | 188.2                 |
| TRSA32-108   | 2.000                           | 108                     | 3.250               | 7.250         | 9.000 | 2.250 | 4.500         | .875 | .562 | .875 | .406      | 3/8-16         | 3/8-16                     | 281.0                 |

### Footnotes:

(1) Two threaded leveling holes per TWIN RAIL® support segment are used for setscrew adjustment to aid in assembly leveling to the user mounting surfaces.

## Dimensions

(inches)

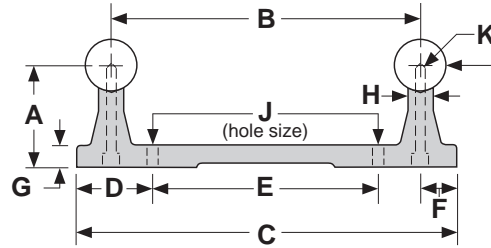

See pages 64 & 65 for end machining options and end stops.

Sold & Serviced By:  
**ELECTROMATE**  
 Toll Free Phone (877) SERV098  
 Toll Free Fax (877) SERV099  
[www.electromate.com](http://www.electromate.com)  
[sales@electromate.com](mailto:sales@electromate.com)

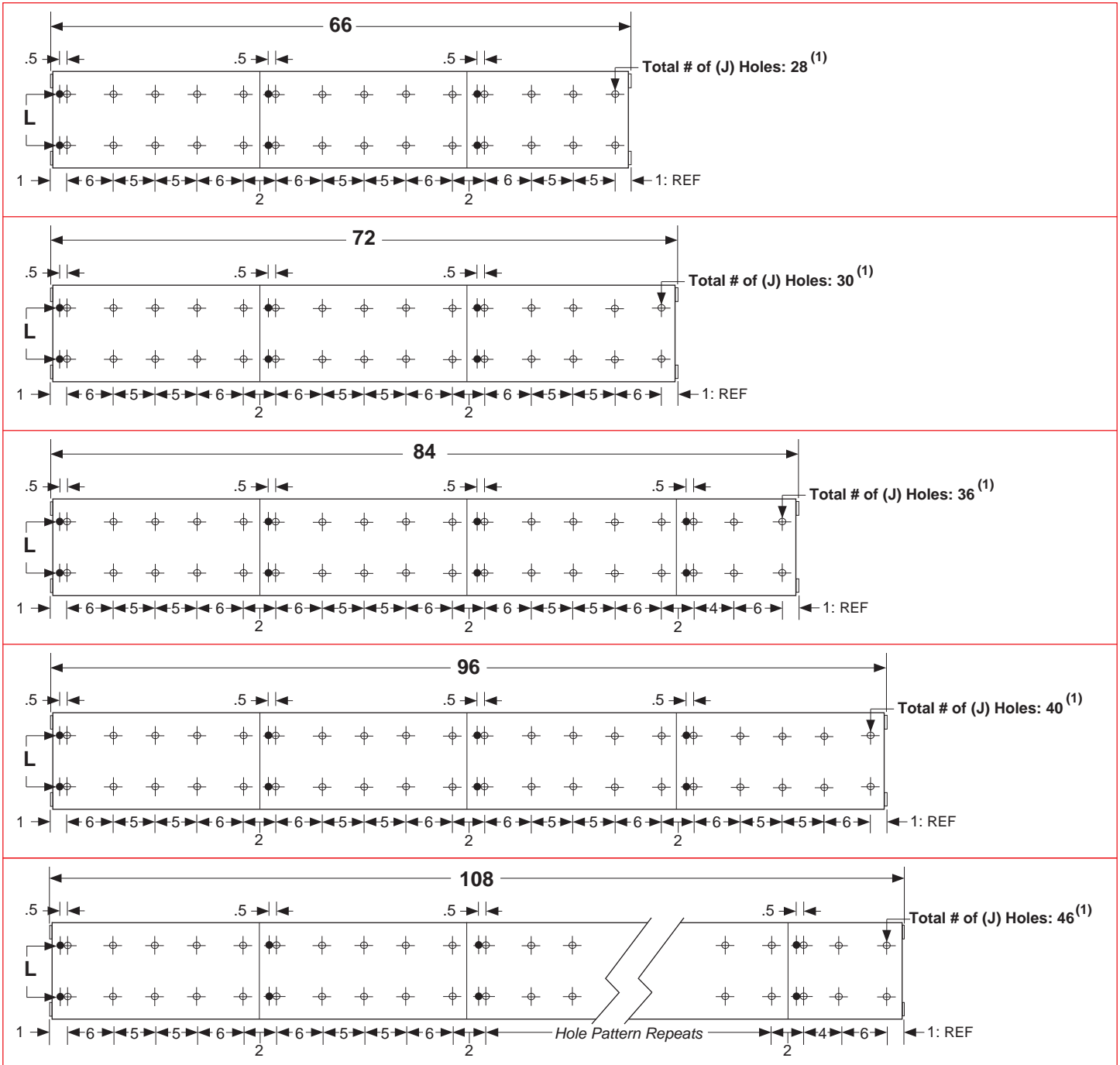

## Footnotes:

(1) *TWIN RAIL*® supports come in 6, 12, 18 and 24 inch segments. The mounting hole location linear tolerance is +/- .010 inches noncumulative per segment. The supports are not one piece for lengths over 24 inches. The mounting hole linear tolerance is +/- .015 inches cumulative from one support segment to the next.

## Dimensions & Specifications: TRSA TWIN RAIL® Shaft Assembly

| Model Number | Nominal Shaft Diameter (inches) | Overall Length (inches) | Dimensions (inches) |               |       |       |               |      |      |      |           |                |                            | Assembly Weight (lbs) |
|--------------|---------------------------------|-------------------------|---------------------|---------------|-------|-------|---------------|------|------|------|-----------|----------------|----------------------------|-----------------------|
|              |                                 |                         | A<br>+/- .002       | B<br>+/- .002 | C     | D     | E<br>+/- .010 | F    | G    | H    | J<br>hole | K<br>Bolt Size | L <sup>(1)</sup><br>Thread |                       |
| TRSA8-120    | 0.500                           | 120                     | 1.125               | 3.000         | 3.750 | 0.875 | 2.000         | .375 | .312 | .250 | .169      | #6-32          | #10-32                     | 35.9                  |
| TRSA10-120   | 0.625                           | 120                     | 1.125               | 3.750         | 4.625 | 1.000 | 2.625         | .437 | .312 | .312 | .193      | #8-32          | #10-32                     | 47.7                  |
| TRSA12-120   | 0.750                           | 120                     | 1.500               | 4.500         | 5.500 | 1.125 | 3.250         | .500 | .312 | .375 | .221      | #10-32         | #10-32                     | 67.2                  |
| TRSA16-120   | 1.000                           | 120                     | 1.750               | 5.250         | 6.375 | 1.312 | 3.750         | .562 | .312 | .500 | .281      | 1/4-20         | #10-32                     | 99.8                  |
| TRSA20-120   | 1.250                           | 120                     | 2.125               | 6.000         | 7.250 | 1.562 | 4.125         | .625 | .375 | .562 | .281      | 1/4-20         | 1/4-20                     | 149.2                 |
| TRSA24-120   | 1.500                           | 120                     | 2.500               | 6.625         | 8.125 | 1.875 | 4.375         | .750 | .437 | .687 | .343      | 5/16-18        | 5/16-18                    | 209.1                 |
| TRSA32-120   | 2.000                           | 120                     | 3.250               | 7.250         | 9.000 | 2.250 | 4.500         | .875 | .562 | .875 | .406      | 3/8-16         | 3/8-16                     | 312.2                 |
| TRSA8-144    | 0.500                           | 144                     | 1.125               | 3.000         | 3.750 | 0.875 | 2.000         | .375 | .312 | .250 | .169      | #6-32          | #10-32                     | 43.1                  |
| TRSA10-144   | 0.625                           | 144                     | 1.125               | 3.750         | 4.625 | 1.000 | 2.625         | .437 | .312 | .312 | .193      | #8-32          | #10-32                     | 57.3                  |
| TRSA12-144   | 0.750                           | 144                     | 1.500               | 4.500         | 5.500 | 1.125 | 3.250         | .500 | .312 | .375 | .221      | #10-32         | #10-32                     | 80.7                  |
| TRSA16-144   | 1.000                           | 144                     | 1.750               | 5.250         | 6.375 | 1.312 | 3.750         | .562 | .312 | .500 | .281      | 1/4-20         | #10-32                     | 119.8                 |
| TRSA20-144   | 1.250                           | 144                     | 2.125               | 6.000         | 7.250 | 1.562 | 4.125         | .625 | .375 | .562 | .281      | 1/4-20         | 1/4-20                     | 179.1                 |
| TRSA24-144   | 1.500                           | 144                     | 2.500               | 6.625         | 8.125 | 1.875 | 4.375         | .750 | .437 | .687 | .343      | 5/16-18        | 5/16-18                    | 251.0                 |
| TRSA32-144   | 2.000                           | 144                     | 3.250               | 7.250         | 9.000 | 2.250 | 4.500         | .875 | .562 | .875 | .406      | 3/8-16         | 3/8-16                     | 374.7                 |
| TRSA12-168   | 0.750                           | 168                     | 1.500               | 4.500         | 5.500 | 1.125 | 3.250         | .500 | .312 | .375 | .221      | #10-32         | #10-32                     | 94.1                  |
| TRSA16-168   | 1.000                           | 168                     | 1.750               | 5.250         | 6.375 | 1.312 | 3.750         | .562 | .312 | .500 | .281      | 1/4-20         | #10-32                     | 139.8                 |
| TRSA20-168   | 1.250                           | 168                     | 2.125               | 6.000         | 7.250 | 1.562 | 4.125         | .625 | .375 | .562 | .281      | 1/4-20         | 1/4-20                     | 208.9                 |
| TRSA24-168   | 1.500                           | 168                     | 2.500               | 6.625         | 8.125 | 1.875 | 4.375         | .750 | .437 | .687 | .343      | 5/16-18        | 5/16-18                    | 292.8                 |
| TRSA32-168   | 2.000                           | 168                     | 3.250               | 7.250         | 9.000 | 2.250 | 4.500         | .875 | .562 | .875 | .406      | 3/8-16         | 3/8-16                     | 437.1                 |
| TRSA12-192   | 0.750                           | 192                     | 1.500               | 4.500         | 5.500 | 1.125 | 3.250         | .500 | .312 | .375 | .221      | #10-32         | #10-32                     | 107.6                 |
| TRSA16-192   | 1.000                           | 192                     | 1.750               | 5.250         | 6.375 | 1.312 | 3.750         | .562 | .312 | .500 | .281      | 1/4-20         | #10-32                     | 159.7                 |
| TRSA20-192   | 1.250                           | 192                     | 2.125               | 6.000         | 7.250 | 1.562 | 4.125         | .625 | .375 | .562 | .281      | 1/4-20         | 1/4-20                     | 238.8                 |
| TRSA24-192   | 1.500                           | 192                     | 2.500               | 6.625         | 8.125 | 1.875 | 4.375         | .750 | .437 | .687 | .343      | 5/16-18        | 5/16-18                    | 334.6                 |
| TRSA32-192   | 2.000                           | 192                     | 3.250               | 7.250         | 9.000 | 2.250 | 4.500         | .875 | .562 | .875 | .406      | 3/8-16         | 3/8-16                     | 499.6                 |

### Footnotes:

(1) Two threaded leveling holes per TWIN RAIL® support segment are used for setscrew adjustment to aid in assembly leveling to the user mounting surfaces.

Sold & Serviced By:



Toll Free Phone (877) SERV098  
Toll Free Fax (877) SERV099

[www.electromate.com](http://www.electromate.com)

[sales@electromate.com](mailto:sales@electromate.com)  
Specifications subject to change without notice

## Dimensions

(inches)

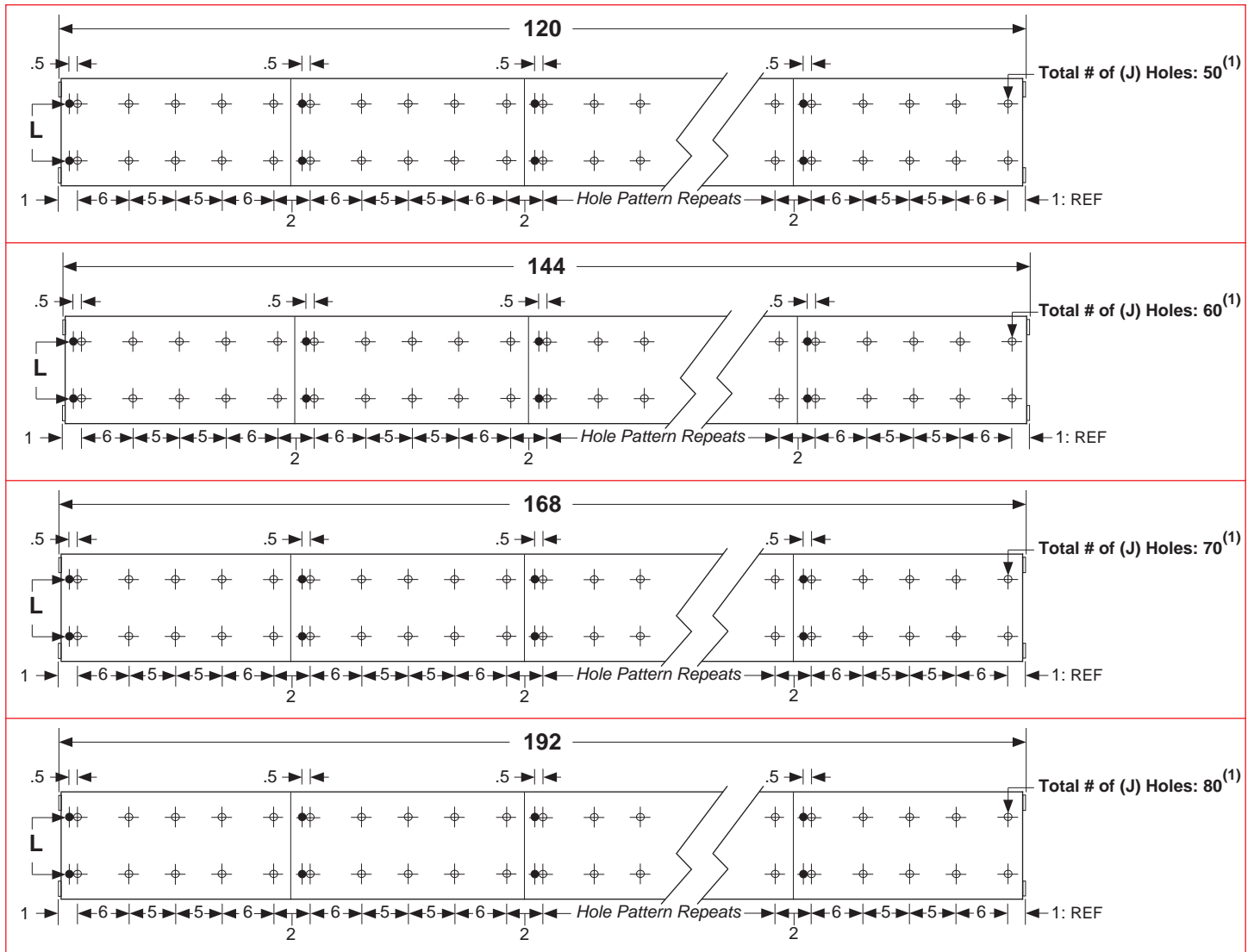
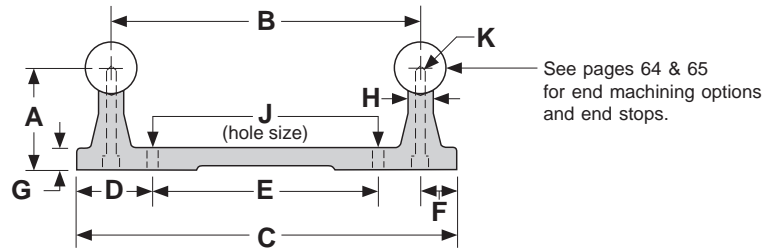

## Footnotes:

(1) TWIN RAIL® supports come in 6, 12, 18 and 24 inch segments. The mounting hole location linear tolerance is +/- .010 inches noncumulative per segment. The supports are not one piece for lengths over 24 inches. The mounting hole linear tolerance is +/- .015 inches cumulative from one support segment to the next.



# Options

## Reduced Diameters, End Stops, Coaxial & Radial Holes

Reduced diameters, end stops, coaxial & radial holes can be provided on any shaft or shaft assembly. The standard tolerance for a reduced diameter is +/- .001 inches, while the concentricity is .002 inches TIR. The shaft may be annealed and soft around the shaft circumference adjacent to the reduced diameter. Coaxial holes are drilled and tapped in the center of the shaft ends and radial holes can be drilled and tapped as desired. The concentricity of the holes will be .005 inches TIR.

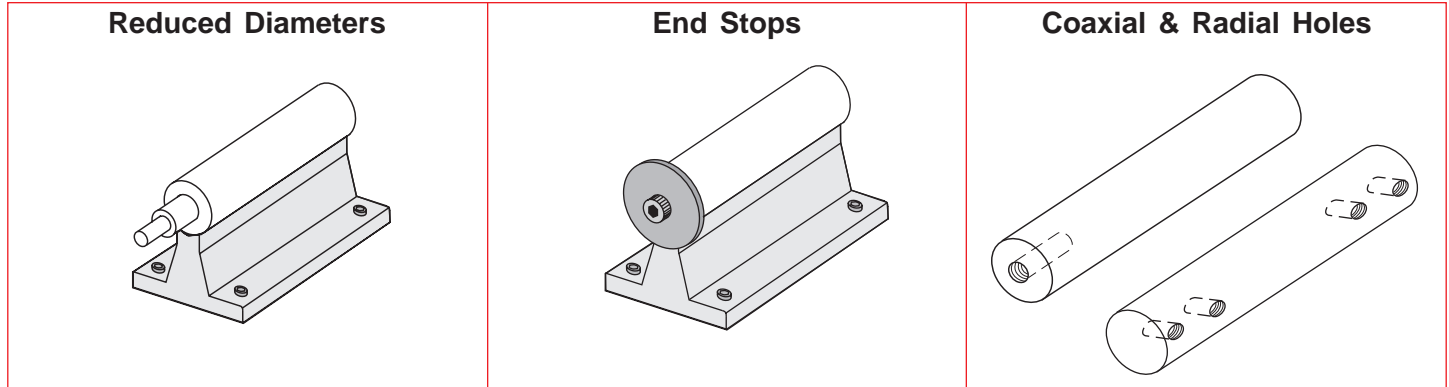

## Butted, Doweled, and Threaded & Ground Joints

Standard shaft assemblies cannot be combined to create longer lengths, as the rolling elements of re-circulating linear bearings will "jam" at the joined ends due to the shaft chamfer. For those long length or custom applications, *LINTECH* provides several options for joining shaft assemblies. Butted, doweled, threaded, and ground joints are available with all shaft lengths and diameters. All of these options will have the standard chamfer removed from the shaft ends. The concentricity of doweled joints is < .001 inches, while the concentricity of butted joints will depend upon the user mounting surface.

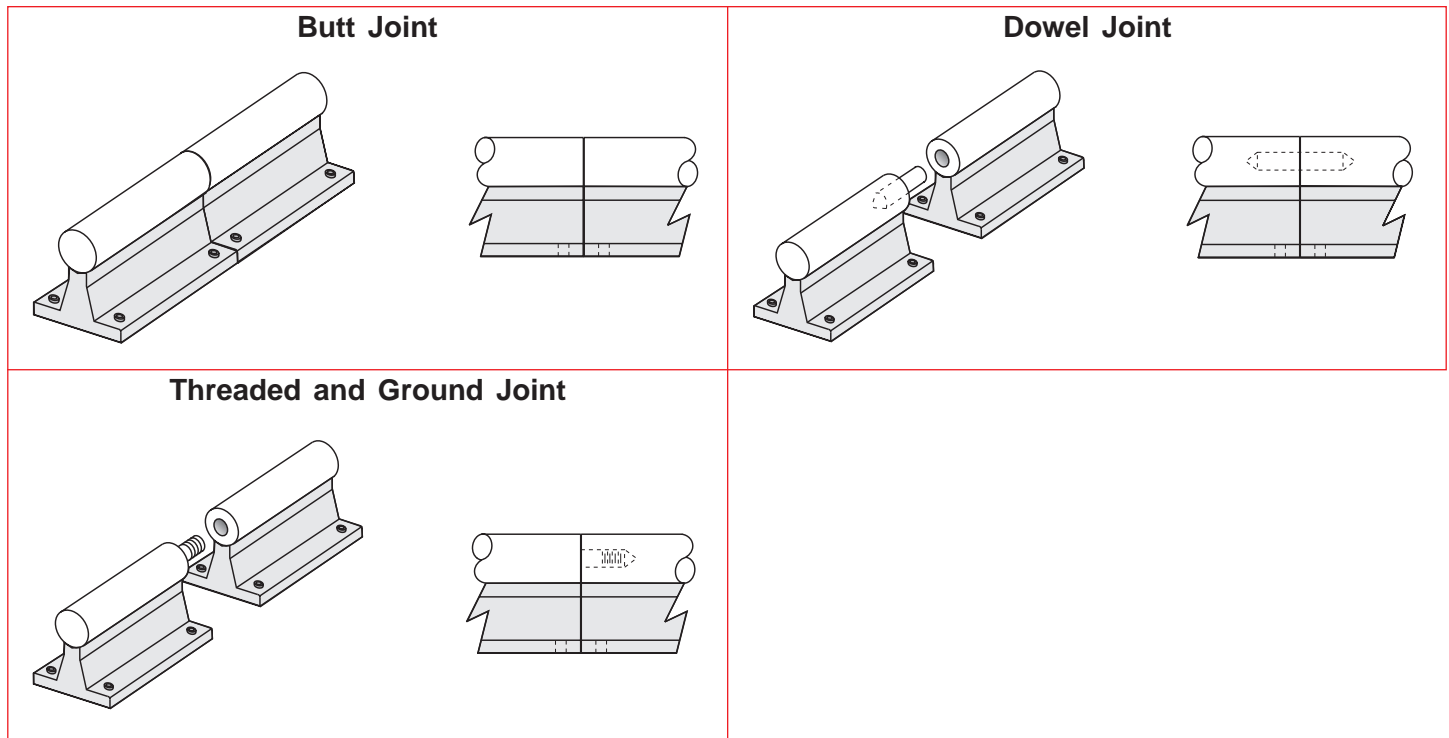

Sold & Serviced By:

 **ELECTROMATE**

Toll Free Phone (877) SERV098

Toll Free Fax (877) SERV099

[www.electromate.com](http://www.electromate.com)

[sales@electromate.com](mailto:sales@electromate.com)

Specifications subject to change without notice

# Options

## Custom Shaft Assembly Lengths & Widths

Custom shaft assembly lengths and widths (shorter and longer) not shown in this catalog can be provided upon request.

## Metric Shaft Assemblies

Metric shaft assemblies can be provided upon request by combining SM shafting with the LSRS or ARS shaft supports.

## Chrome Plated Shafts

For applications in high moisture, high humidity, clean room, or highly corrosive environments, chrome plating of the shafts will offer superior resistance to corrosion. The process uniformly deposits dense, hard, high Chromium alloy onto the shaft, and has a Rockwell C hardness value of 67-72. This process also conforms to MIL Spec: (MIL-C-23422). The chrome plating bonds to the parent steel and will not crack or peel off under the high point loading of the balls on the shaft. This chrome plating process differs from normal hard chrome which just lays on the surface of the part plated.

## Shaft Support Finishes

The standard anodized finish of the aluminum shaft supports can be changed to meet the requirements needed for operation in clean rooms, food processing facilities, highly corrosive environments, or for different appearances. The standard enamel finish of the steel shaft supports can also be changed. Available options are clear or color anodized, chem-film, nickel plated, chrome plated, different oxide color finishes, or painted per customer specifications.

## Shaft Support End Stops

End stops are available for every shaft assembly size and length. They provide a mechanical stop for the linear bearings to prevent them from sliding off the end of the shaft. The shaft ends are drilled, tapped, and a washer is installed using a cap screw and lock washer.

| Number of <sup>(2)</sup><br>End Stops<br>(see model #) | Nominal<br>Shaft Dia.<br>(inches) | Dimensions<br>(inches) |      |       |                               |
|--|-----------------------------------|------------------------|------|-------|-------------------------------|
|  |                                   | A                      | B    | C     | D <sup>(1)</sup><br>Cap Screw |
| E1, E2, E3, E4   | 0.500                             | .375                   | .062 | 1.125 | 1/4                           |
| E1, E2, E3, E4   | 0.625                             | .453                   | .062 | 1.375 | 5/16                          |
| E1, E2, E3, E4   | 0.750                             | .532                   | .062 | 1.625 | 3/8                           |
| E1, E2, E3, E4   | 1.000                             | .656                   | .109 | 1.812 | 7/16                          |
| E1, E2, E3, E4   | 1.250                             | .750                   | .125 | 2.250 | 1/2                           |
| E1, E2, E3, E4   | 1.500                             | .750                   | .125 | 2.625 | 1/2                           |
| E1, E2, E3, E4   | 2.000                             | .750                   | .125 | 3.250 | 1/2                           |

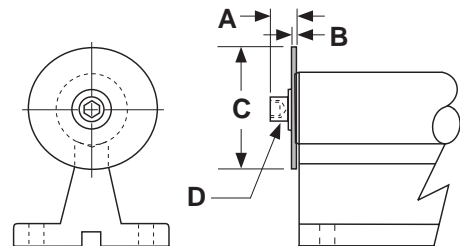

### Footnotes:

- (1) Cap screw for end stops have black oxide finish. End stop & cap screw lock washers are Cadmium plated (QQ-P-416 Type II).
- (2) When only Specifying one end stop (E1) for SA, or two end stops for the TRSA (E2), the end stops will be installed on the left hand end of the assembly, as depicted by the above drawing, unless specified otherwise.

# Unit Conversions

## Torque Conversions

| Present Units    | Convert To            | Multiply By |
|------------------|-----------------------|-------------|
| Gram-centimeters | newton-meters -----   | 0.0000981   |
| Gram-centimeters | ounce-inches -----    | 0.0138874   |
| Gram-centimeters | pound-inches -----    | 0.000868    |
| Gram-centimeters | pound-feet -----      | 0.0000723   |
| Newton-meters    | gram-centimeters ---- | 10,197.162  |
| Newton-meters    | ounce-inches -----    | 141.612     |
| Newton-meters    | pound-inches -----    | 8.85        |
| Newton-meters    | pound-feet -----      | 0.73756     |
| Ounce-inches     | gram-centimeters ---- | 72.0077     |
| Ounce-inches     | newton-meters -----   | 0.007062    |
| Ounce-inches     | pound-inches -----    | 0.0625      |
| Ounce-inches     | pound-feet -----      | 0.005208    |
| Pound-inches     | gram-centimeters ---- | 1,152.0     |
| Pound-inches     | newton-meters -----   | 0.11299     |
| Pound-inches     | ounce-inches -----    | 16.0        |
| Pound-inches     | pound-feet -----      | 0.08333     |
| Pound-feet       | gram-centimeters ---- | 13,825.5    |
| Pound-feet       | newton-meters -----   | 1.3558      |
| Pound-feet       | ounce-inches -----    | 192.0       |
| Pound-feet       | pound-inches -----    | 12.0        |

## Distance Conversions

| Present Units | Convert To        | Multiply By |
|---------------|-------------------|-------------|
| Arc-minutes   | degrees -----     | 0.016666    |
| Arc-seconds   | degrees -----     | 0.000277    |
| Centimeters   | inches -----      | 0.3937      |
| Centimeters   | feet -----        | 0.03280     |
| Centimeters   | microns -----     | 10,000.0    |
| Degrees       | arc-minutes ----  | 60.0        |
| Degrees       | arc-seconds ----  | 3,600.0     |
| Degrees       | radians -----     | 0.017453    |
| Feet          | centimeters ----- | 30.48       |
| Feet          | meters -----      | 0.3048      |
| Inches        | centimeters ----  | 2.54        |
| Inches        | Km -----          | 0.0000254   |
| Inches        | meters -----      | 0.0254      |
| Inches        | microns -----     | 25,400.0    |
| Inches        | millimeters ----  | 25.4        |
| Km            | inches -----      | 39,370.0    |
| Meters        | feet -----        | 3.2808      |
| Meters        | inches -----      | 39.37       |
| Meters        | microns -----     | 1,000,000.0 |
| Microns       | centimeters ----  | 0.0001      |
| Microns       | inches -----      | 0.00003937  |
| Microns       | meters -----      | 0.000001    |
| Microns       | millimeters ----  | 0.001       |
| Millimeters   | inches -----      | 0.03937     |
| Millimeters   | microns -----     | 1,000.0     |
| Radians       | degrees -----     | 57.295779   |

## Inertia Conversions

| Present Units               | Convert To                     | Multiply By  |
|-----------------------------|--------------------------------|--------------|
| Gram-cm <sup>2</sup>        | ounce-inches <sup>2</sup> ---- | 0.00546745   |
| Gram-cm <sup>2</sup>        | ounce-inch-sec <sup>2</sup> -- | 0.000014161  |
| Gram-cm <sup>2</sup>        | pound-inches <sup>2</sup> ---- | 0.000341716  |
| Gram-cm <sup>2</sup>        | pound-inch-sec <sup>2</sup> -- | 0.000000885  |
| Gram-cm <sup>2</sup>        | pound-feet-sec <sup>2</sup> -- | 0.000000074  |
| Ounce-inches <sup>2</sup>   | gram-cm <sup>2</sup> -----     | 182.901      |
| Ounce-inches <sup>2</sup>   | ounce-inch-sec <sup>2</sup> -- | 0.00259008   |
| Ounce-inches <sup>2</sup>   | pound-inches <sup>2</sup> ---- | 0.0625       |
| Ounce-inches <sup>2</sup>   | pound-inch-sec <sup>2</sup> -- | 0.00016188   |
| Ounce-inches <sup>2</sup>   | pound-feet-sec <sup>2</sup> -- | 0.00001349   |
| Ounce-inch-sec <sup>2</sup> | gram-cm <sup>2</sup> -----     | 70,615.4     |
| Ounce-inch-sec <sup>2</sup> | ounce-inches <sup>2</sup> ---- | 386.0        |
| Ounce-inch-sec <sup>2</sup> | pound-inches <sup>2</sup> ---- | 24.13045     |
| Ounce-inch-sec <sup>2</sup> | pound-inch-sec <sup>2</sup> -- | 0.0625       |
| Ounce-inch-sec <sup>2</sup> | pound-feet-sec <sup>2</sup> -- | 0.00520833   |
| Pound-inches <sup>2</sup>   | gram-cm <sup>2</sup> -----     | 2,926.41     |
| Pound-inches <sup>2</sup>   | ounce-inches <sup>2</sup> ---- | 16.0         |
| Pound-inches <sup>2</sup>   | ounce-inch-sec <sup>2</sup> -- | 0.0414413    |
| Pound-inches <sup>2</sup>   | pound-inch-sec <sup>2</sup> -- | 0.00259008   |
| Pound-inches <sup>2</sup>   | pound-feet-sec <sup>2</sup> -- | 0.00021584   |
| Pound-inch-sec <sup>2</sup> | gram-cm <sup>2</sup> -----     | 1,129,850.0  |
| Pound-inch-sec <sup>2</sup> | ounce-inches <sup>2</sup> ---- | 6,177.4      |
| Pound-inch-sec <sup>2</sup> | ounce-inch-sec <sup>2</sup> -- | 16.0         |
| Pound-inch-sec <sup>2</sup> | pound-inches <sup>2</sup> ---- | 386.0        |
| Pound-inch-sec <sup>2</sup> | pound-feet-sec <sup>2</sup> -- | 0.0833333    |
| Pound-feet-sec <sup>2</sup> | gram-cm <sup>2</sup> -----     | 13,558,200.0 |
| Pound-feet-sec <sup>2</sup> | ounce-inches <sup>2</sup> ---  | 74,128.9     |
| Pound-feet-sec <sup>2</sup> | ounce-inch-sec <sup>2</sup> -- | 192.0        |
| Pound-feet-sec <sup>2</sup> | pound-inches <sup>2</sup> ---  | 4,633.06     |
| Pound-feet-sec <sup>2</sup> | pound-inch-sec <sup>2</sup> -  | 12.0         |

## Load Conversions

| Present Units | Convert To      | Multiply By |
|---------------|-----------------|-------------|
| Grams         | newtons -----   | 0.009806    |
| Grams         | ounces -----    | 0.03528     |
| Grams         | pounds -----    | 0.002204    |
| Kilograms     | pounds -----    | 2.2046      |
| Newtons       | grams -----     | 101.971     |
| Newtons       | ounces -----    | 3.59692     |
| Newtons       | pounds -----    | 0.224808    |
| Ounces        | grams -----     | 28.3495     |
| Ounces        | newtons -----   | 0.27802     |
| Ounces        | pounds -----    | 0.0625      |
| Pounds        | grams -----     | 453.592     |
| Pounds        | kilograms ----- | 0.45359     |
| Pounds        | newtons -----   | 4.44824     |
| Pounds        | ounces -----    | 16.0        |
| Pounds        | tons -----      | 0.0005      |
| Tons          | pounds -----    | 2,000.0     |