

Motor Couplings

LINTECH provides three different types of couplings that can be used to interface a motor to a ball screw assembly. These couplings compensate for some misalignment between the motor shaft & lead screw, or drive shaft extension. This provides for trouble-free operation as long as certain precautions are taken. The connected motor or gearhead output torque should never exceed the coupling maximum torque capacity. Larger capacity couplings may be required for high accelerations, large back driving loads, high torque output motors, servo motors, or gear boxes.

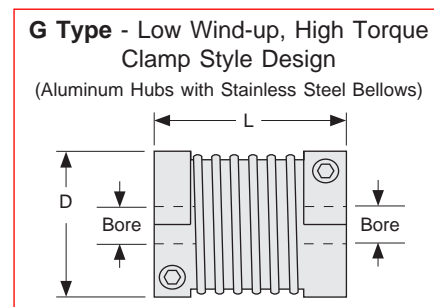
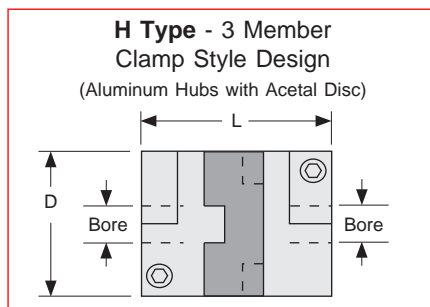
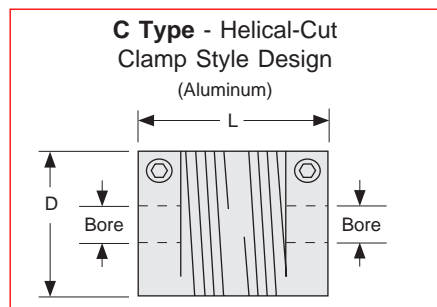

Model #	D inches (mm)	L inches (mm)	Screw	Bore Diameters				Weight ounces (grams)	Inertia oz-in ² (g-cm ²)	Wind-up arc-sec/oz-in (deg/N-m)	Max Torque oz-in (N-m)
				Motor	Minimum (in) (mm)	Maximum (in) (mm)					
C100-xxx-aaa	1.00 (25,4)	1.50 (38,1)	xxx	aaa	.250 6	.375 10	1.5 (43)	.19 (35)	23.0 (0,9)	400 (2,8)	
C125-xxx-aaa	1.25 (31,8)	2.00 (50,8)	xxx	aaa	.250 6	.500 14	3.5 (99)	.68 (124)	15.0 (0,59)	700 (4,9)	
C150-xxx-aaa	1.50 (38,1)	2.37 (60,2)	xxx	aaa	.375 10	.625 16	5.5 (156)	1.54 (282)	13.0 (0,51)	950 (4,9)	
H100-xxx-aaa	1.00 (25,4)	1.28 (32,5)	xxx	aaa	.250 6	.375 10	1.2 (34)	.15 (27)	7.2 (0,28)	450 (2,8)	
H131-xxx-aaa	1.31 (33,3)	1.89 (48,0)	xxx	aaa	.250 6	.625 16	2.9 (82)	.62 (114)	2.5 (0,098)	1,000 (7,1)	
H163-xxx-aaa	1.63 (41,4)	2.00 (50,8)	xxx	aaa	.375 10	.750 20	5.4 (153)	1.79 (328)	1.2 (0,047)	2,000 (14,1)	
H197-xxx-aaa	1.97 (50,0)	2.35 (59,7)	xxx	aaa	.375 10	.750 20	7.6 (215)	3.69 (674)	1.1 (0,043)	3,600 (25,4)	
H225-xxx-aaa	2.25 (57,2)	3.07 (78,0)	xxx	aaa	.500 12	1.000 24	13.1 (371)	8.29 (1516)	0.6 (0,024)	5,300 (37,4)	
G100-xxx-aaa	0.99 (25,2)	1.26 (32,0)	xxx	aaa	.250 6	.500 12	1.3 (36)	.16 (29)	1.0 (0,39)	500 (3,5)	
G126-xxx-aaa	1.26 (32,1)	1.62 (41,0)	xxx	aaa	.250 6	.625 16	2.7 (74)	.54 (99)	0.3 (0,012)	1,100 (7,7)	
G158-xxx-aaa	1.58 (40,2)	1.85 (47,0)	xxx	aaa	.375 10	.750 20	4.3 (120)	1.34 (245)	0.2 (0,008)	2,400 (17,0)	
G177-xxx-aaa	1.77 (45,0)	2.48 (63,0)	xxx	aaa	.375 10	.750 20	7.1 (200)	2.78 (508)	0.2 (0,008)	4,250 (30,0)	
G220-xxx-aaa	2.20 (56,0)	2.56 (65,0)	xxx	aaa	.500 12	1.000 24	10.6 (300)	6.41 (1172)	0.04 (0,002)	7,100 (50,0)	
Possible values for aaa	250 = .250 inch 375 = .375 inch 500 = .500 inch 625 = .625 inch	750 = .750 inch 999 = 1.000 inch			005 = 5 mm 006 = 6 mm 008 = 8 mm 010 = 10 mm	012 = 12 mm 014 = 14 mm 016 = 16 mm 018 = 18 mm	019 = 19 mm 020 = 20 mm 024 = 24 mm				

Motor Couplings

Coupling	Cost	Torque Capacity	Wind-up	Suggested Motor	Comments
C Type	least expensive	light	the most	stepper	ideal for most step motor applications
H Type	medium priced	medium	medium	stepper or servo	use for high accels & for starting & stopping large inertia loads
G Type	most expensive	high	the least	servo	use for very high torque requirements & very high servo accelerations

Specification		Ball Screw Diameters								
		0.500 inch		0.625 inch & 16 mm		0.750 inch & 20 mm		1.000 inch		1.500 inch
		NEMA 23 Mount	NEMA 34 Mount	NEMA 23 Mount	NEMA 34 Mount	NEMA 23 Mount	NEMA 34 Mount	NEMA 34 Mount	NEMA 42 Mount	NEMA 42 Mount
Shaft extension diameter at motor mount end	inches (mm)	.312 (7,92)		.375 (9,52)		.500 (12,70)		.625 (15,87)		.750 (19,05)
Maximum coupling diameter	inches (mm)	2.00 (50,8)	2.00 (50,8)	2.00 (50,8)	2.00 (50,8)	2.00 (50,8)	2.00 (50,8)	3.20 (50,8)	2.80 (71,1)	3.80 (96,5)
Maximum coupling length	inches (mm)	2.10 (53,3)	2.10 (53,3)	2.10 (53,3)	2.10 (53,3)	2.10 (53,3)	2.10 (53,3)	2.60 (66,0)	3.60 (91,4)	3.40 (86,4)

Note: Custom motor mounts available upon request.

C020 C100-312-250	C090 C150-500-016	C171 H131-500-010	C281 H197-750-375	C435 G126-375-250	C492 G158-625-375
C021 C100-312-375	C091 C150-625-375	C172 H131-500-012	C282 H197-750-500	C436 G126-375-375	C493 G158-625-500
C022 C100-312-006	C092 C150-625-500	C173 H131-500-014	C283 H197-750-625	C437 G126-375-500	C494 G158-625-625
C023 C100-312-008	C093 C150-625-625	C174 H131-500-016	C284 H197-750-750	C438 G126-375-625	C495 G158-625-750
C024 C100-312-010	C094 C150-625-010	C175 H131-625-375	C285 H197-750-010	C439 G126-375-006	C496 G158-625-010
C025 C100-375-250	C095 C150-625-012	C176 H131-625-500	C286 H197-750-012	C440 G126-375-008	C497 G158-625-012
C026 C100-375-375	C096 C150-625-014	C177 H131-625-006	C287 H197-750-014	C441 G126-375-010	C498 G158-625-014
C027 C100-375-006	C097 C150-625-016	C178 H131-625-008	C288 H197-750-016	C442 G126-375-012	C499 G158-625-016
C028 C100-375-008	C125 H100-312-250	C179 H131-625-010	C289 H197-750-018	C443 G126-375-014	C500 G158-625-018
C029 C100-375-010	C126 H100-312-375	C180 H131-625-012	C290 H197-750-019	C444 G126-375-016	C501 G158-625-019
C040 C125-312-250	C127 H100-312-006	C181 H131-625-014	C291 H197-750-020	C445 G126-500-250	C502 G158-625-020
C041 C125-312-375	C128 H100-312-008	C182 H131-625-016	C337 H225-750-500	C446 G126-500-375	C503 G158-750-375
C042 C125-312-500	C129 H100-312-010	C201 H163-500-375	C338 H225-750-625	C447 G126-500-500	C504 G158-750-500
C043 C125-312-006	C130 H100-375-250	C202 H163-500-500	C339 H225-750-750	C448 G126-500-625	C505 G158-750-625
C044 C125-312-008	C131 H100-375-375	C203 H163-500-625	C340 H225-750-999	C449 G126-500-006	C506 G158-750-750
C045 C125-312-010	C132 H100-375-006	C204 H163-500-750	C341 H225-750-012	C450 G126-500-008	C507 G158-750-010
C046 C125-312-012	C133 H100-375-008	C205 H163-500-010	C342 H225-750-014	C451 G126-500-010	C508 G158-750-012
C047 C125-312-014	C134 H100-375-010	C206 H163-500-012	C343 H225-750-016	C452 G126-500-012	C509 G158-750-014
C048 C125-375-250	C145 H131-312-250	C207 H163-500-014	C344 H225-750-018	C453 G126-500-014	C510 G158-750-016
C049 C125-375-375	C146 H131-312-375	C208 H163-500-016	C345 H225-750-019	C454 G126-500-016	C511 G158-750-018
C050 C125-375-500	C147 H131-312-500	C209 H163-500-018	C346 H225-750-020	C455 G126-625-375	C512 G158-750-019
C051 C125-375-006	C148 H131-312-625	C210 H163-500-019	C347 H225-750-024	C456 G126-625-500	C513 G158-750-020
C052 C125-375-008	C149 H131-312-006	C211 H163-500-020	C400 G100-312-250	C457 G126-625-625	C561 G177-750-375
C053 C125-375-010	C150 H131-312-008	C212 H163-625-375	C401 G100-312-375	C458 G126-625-008	C562 G177-750-500
C054 C125-375-012	C151 H131-312-010	C213 H163-625-500	C402 G100-312-500	C459 G126-625-010	C563 G177-750-625
C055 C125-375-014	C152 H131-312-012	C214 H163-625-625	C403 G100-312-006	C460 G126-625-012	C564 G177-750-750
C056 C125-500-250	C153 H131-312-014	C215 H163-625-750	C404 G100-312-008	C461 G126-625-014	C565 G177-750-010
C057 C125-500-375	C154 H131-312-016	C216 H163-625-010	C405 G100-312-010	C462 G126-625-016	C566 G177-750-012
C058 C125-500-500	C155 H131-375-250	C217 H163-625-012	C406 G100-312-012	C481 G158-500-375	C567 G177-750-014
C059 C125-500-006	C156 H131-375-375	C218 H163-625-014	C407 G100-375-250	C482 G158-500-500	C568 G177-750-016
C060 C125-500-008	C157 H131-375-500	C219 H163-625-016	C408 G100-375-375	C483 G158-500-625	C569 G177-750-018
C061 C125-500-010	C158 H131-375-625	C220 H163-625-018	C409 G100-375-500	C484 G158-500-750	C570 G177-750-019
C062 C125-500-012	C159 H131-375-006	C221 H163-625-019	C410 G100-375-006	C485 G158-500-010	C571 G177-750-020
C063 C125-500-014	C160 H131-375-008	C222 H163-625-020	C411 G100-375-008	C486 G158-500-012	C617 G220-750-500
C064 C125-625-375	C161 H131-375-010	C223 H163-750-375	C412 G100-375-010	C487 G158-500-014	C618 G220-750-625
C065 C125-625-500	C162 H131-375-012	C224 H163-750-500	C413 G100-375-012	C488 G158-500-016	C619 G220-750-750
C066 C125-625-010	C163 H131-375-014	C225 H163-750-625	C425 G126-312-250	C489 G158-500-018	C620 G220-750-999
C067 C125-625-012	C164 H131-375-016	C226 H163-750-750	C426 G126-312-375	C490 G158-500-019	C621 G220-750-012
C068 C125-625-014	C165 H131-500-250	C227 H163-750-010	C427 G126-312-500	C491 G158-500-020	C622 G220-750-014
C084 C150-500-375	C166 H131-500-375	C228 H163-750-012	C428 G126-312-625	C623 G220-750-016	C624 G220-750-018
C085 C150-500-500	C167 H131-500-500	C229 H163-750-014	C429 G126-312-006	C625 G220-750-019	C626 G220-750-020
C086 C150-500-625	C168 H131-500-625	C230 H163-750-016	C430 G126-312-008	C627 G220-750-024	
C087 C150-500-010	C169 H131-500-006	C231 H163-750-018	C431 G126-312-010		
C088 C150-500-012	C170 H131-500-008	C232 H163-750-019	C432 G126-312-012		
C089 C150-500-014		C233 H163-750-020	C433 G126-312-014		
			C434 G126-312-016		

Hand Crank

For manually operated applications, *LINTECH* provides a hand crank option for 0.500 inch, 0.625 inch, 0.750 inch, 16 mm, and 20 mm diameter screws. If ordered, the hand crank would be installed at the drive end (normally where the motor mount would be).

Sold & Serviced By:



Toll Free Phone (877) SERV098

Toll Free Fax (877) SERV099

www.electromate.com

sales@electromate.com

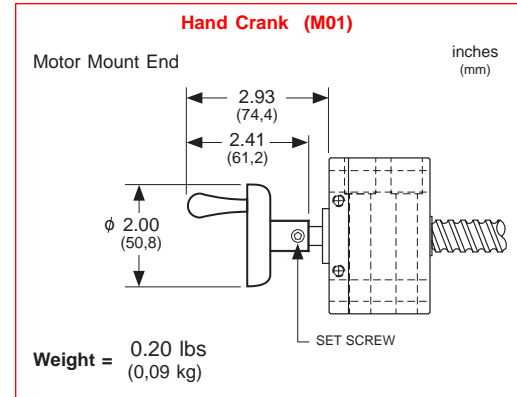

Other Motor Mounts

For motor driven applications, *LINTECH* provides NEMA 23, 34 and 42 motor mounts that easily adapt to either a fixed or rigid bearing housing. For non-NEMA motors, *LINTECH* provides custom motor mounts upon request.

Wiper kits

Wiper kits are only available on the ball nut versions of the RS series assemblies. These brush type wiper kits aid in keeping foreign particles from penetrating the ball nut, and help spread lubricant over the screw as the nut travels back & forth. The wiper kit adds the below lengths to a particular ball nut, thus the overall thread length will increase for a set travel length requirement. Also, one of the nut flange types (F1, F2, F3, F4, or F5) is required to hold the wiper kit in place on the ball nut.

Model Number	A in (mm)	B in (mm)
RS050	.139 (3,53)	.148 (3,76)
RS062	.139 (3,53)	.148 (3,76)
RS075	.158 (4,01)	.148 (3,76)

Model Number	A in (mm)	B in (mm)
RS100	.158 (4,01)	.148 (3,76)
RS150025	.158 (4,01)	.148 (3,76)
RS150050 RS150100 RS150200	0.0 (0,0)	0.0 (0,0)

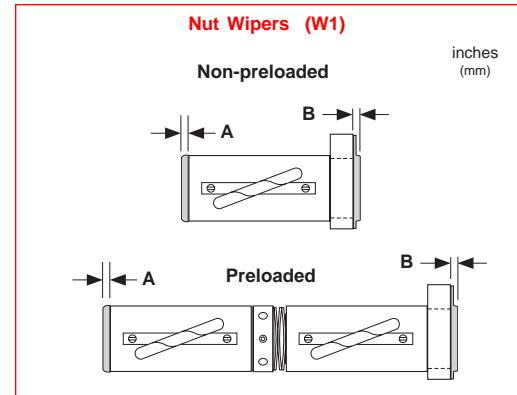

Bellows

Bellows (covers) are available to protect the ball screw & nut from particulates present in the environment. The bellows are designed as a custom fit over the entire length of the screw. Contact the factory for assistance when bellows are required for an application.

Chrome Plated Screw, Nut, Support Housings, and Flange

For applications in high moisture, high humidity, clean room, or highly corrosive environments, chrome plating of the ball screw, ball nut, supports, and flanges will offer superior resistance to corrosion than stainless steel, resulting in longer life. The process uniformly deposits dense, hard, high Chromium alloy on the screw and nut, and has a case hardness value of Rc 67-72. This process also conforms to MIL spec.: (MIL-C-23422). The chrome plating bonds to the parent material and will not crack, chip or peel under load of the balls on the screw. This chrome plating process differs from a normal chrome plate which just lays on the surface of the plated part.

Motor Wrap Packages

For space limited motor driven applications, a belt and pulley system can couple the ball screw to the motor shaft. This wraps the motor parallel to the ball screw assembly in order to decrease the overall ball screw assembly length. Pulley weights and diameters are given in order to assist in calculating motor torque requirements. This option is available only with the fixed and rigid bearing housings and are shown below in the right hand wrap configurations.

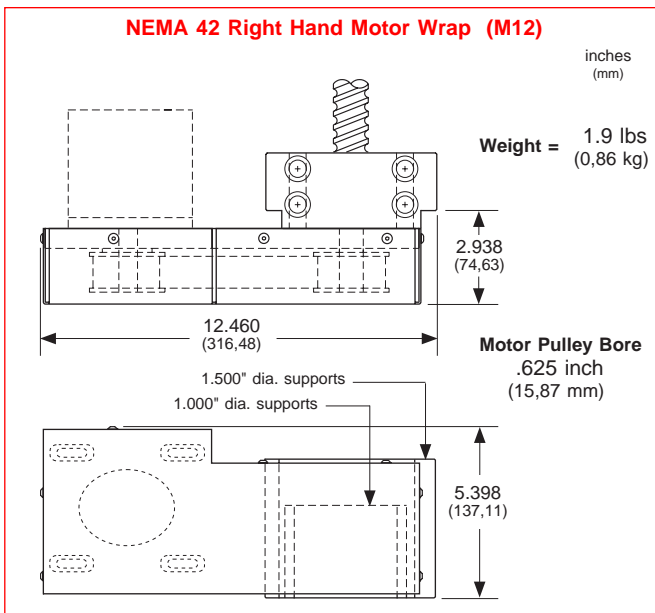
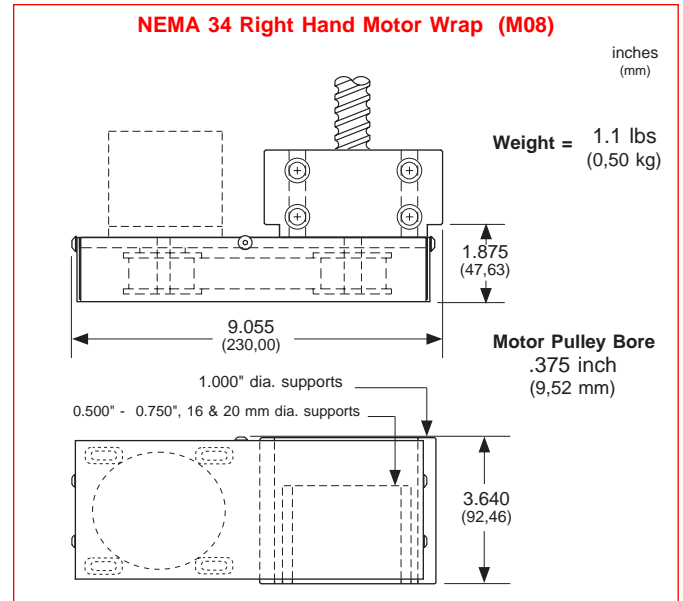
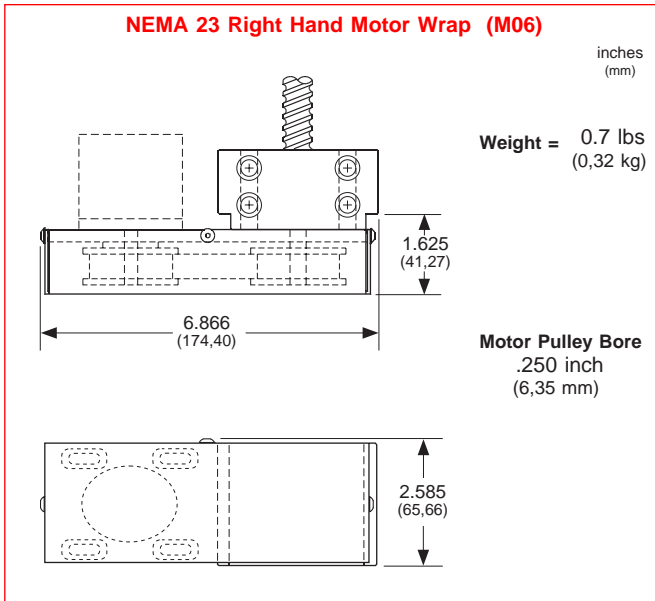

Note: Right hand motor wraps shown. The left hand wrap packages orient the motor to the opposite side of the bearing housing. Motor pulley & belt shipped "loose". No motor mount nuts & bolts are provided. Custom motor wrap packages are available upon request. Other motor pulley bores MUST be specified for non-NEMA motors.

Sold & Serviced By:

 Toll Free Phone (877) SERV098
 Toll Free Fax (877) SERV099
www.electromate.com
sales@electromate.com

Motor Wrap Frame Size	Motor Pulley Dia. inches (mm)	Motor Pulley Weight ounces (kgf)	Screw Pulley Dia. inches (mm)	Screw Pulley Weight ounces (kgf)	Belt Weight ounces (kgf)
NEMA 23	1.65 (41,9)	7.5 (0,21)	1.65 (41,9)	7.5 (0,21)	1.0 (0,028)
NEMA 34	1.65 (41,9)	8.0 (0,23)	1.65 (41,9)	8.0 (0,23)	1.2 (0,034)
NEMA 42	2.12 (53,9)	19.2 (0,54)	2.12 (53,9)	19.2 (0,54)	3.0 (0,085)

Rotary Incremental Encoders

Fully enclosed, shaftless, incremental, optical rotary encoders can be mounted to the screw extension located on the support housing opposite the motor mount end. These encoders are mounted to an adapter plate that is mounted to the face of the housing. An incremental encoder is ideal for providing positional feedback to either a motion controller, or a digital position display.

Specification	ROTARY ENCODERS		
	E20/E24	E21/E25	E22/E26
Line Count	500 lines/rev	1000 lines/rev	1270 lines/rev
Pre Quadrature Resolution	0.002 revs/pulse	0.001 revs/pulse	0.00079 revs/pulse
Post Quadrature Resolution	0.0005 revs/pulse	0.00025 revs/pulse	0.00019 revs/pulse
Maximum Speed	60 revs/sec		
Maximum Accel	4 G's		
Excitation Power	+ 5 VDC @ 125 ma		
Operating Temperature	32° F to 230° F (0° C to 100° C)		
Humidity	20% to 98% non condensing		
Shock	50 G's for 11 msec duration		
Weight	4.5 ounces		
Cable Length	10 ft (3 m), unterminated 26 gauge leads		
Zero Reference Output	Once per revolution		
Outputs	TTL square wave; Two channel (A+ & B+); Differential (A- & B-); Line Driver		

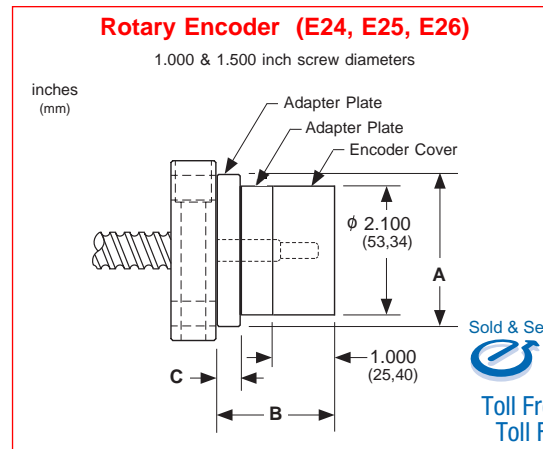
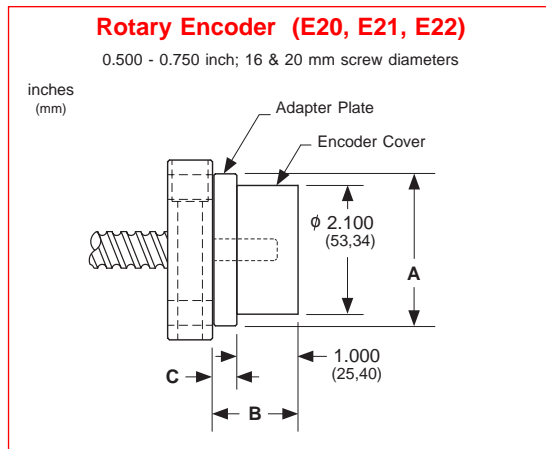

Sold & Serviced By:

 Toll Free Phone (877) SERV098
 Toll Free Fax (877) SERV099
www.electromate.com
sales@electromate.com

Wire Color	Description
White	Channel A ⁺ (or A)
Blue	Channel A ⁻ (or \bar{A})
Green	Channel B ⁺ (or B)
Orange	Channel B ⁻ (or \bar{B})
White/Black	Channel Z ⁺ (or Z)
Red/Black	Channel Z ⁻ (or \bar{Z})
Black	Common
Red	+ 5 vdc (+/- 5%)

Screw Diameters	Encoder Version	A in (mm)	B in (mm)	C in (mm)	Weight lbs (kgf)
0.500 to 0.750 inch 16 & 20 mm	E20, E21 & E22	2.500 (63,50)	1.375 (34,92)	0.375 (9,52)	1.0 (0,45)
1.000 inch	E24, E25 & E26	3.500 (88,90)	2.200 (55,88)	0.500 (12,70)	1.4 (0,63)
1.500 inch	E24, E25 & E26	4.250 (107,95)	2.425 (61,59)	0.625 (15,87)	1.6 (0,73)

Power-off Electric Brakes

For vertical applications, or for those applications requiring the load to be locked securely in place, an electric brake may be mounted to the ball screw assembly. The RS, PS, GS series can have the brake mounted to the screw extension located on the support housing opposite the motor mount end. This power-off friction brake ensures the ball screw is firmly held in place when no electric power is applied. This prevents the ball screw from rotating. When power is applied to the brake, the brake is opened or "released", thus, allowing rotation of the screw. For proper emergency holding of the ball screw, this electric brake needs to be interfaced to a position controller or relay network. *LINTECH* also provides 24 & 90 VDC power supplies which can be used to power the brakes.

Screw Diameters	Brake Version	Holding Force	Excitation Voltage	Current
		in-lbs (N-m)	volts	amps
0.500 to 0.750 inch 16 & 20 mm	B20	18 (2,03)	24 VDC	0.733
	B21	18 (2,03)	90 VDC	0.178
1.000 inch	B22	84 (9,49)	24 VDC	0.973
	B23	84 (9,49)	90 VDC	0.239
1.500 inch	B24	180 (20,3)	24 VDC	1.136
	B25	180 (20,3)	90 VDC	0.287

Note: This power-off electric brake MUST NOT be engaged when the ball screw is in motion. Moving the screw with the brake applied could damage the brake and the ball screw assembly. Also, continuous use of this brake to stop the load that is in motion could damage the brake and the ball screw assembly. Dynamic braking of a ball screw assembly should be done by the motor and not the brake.

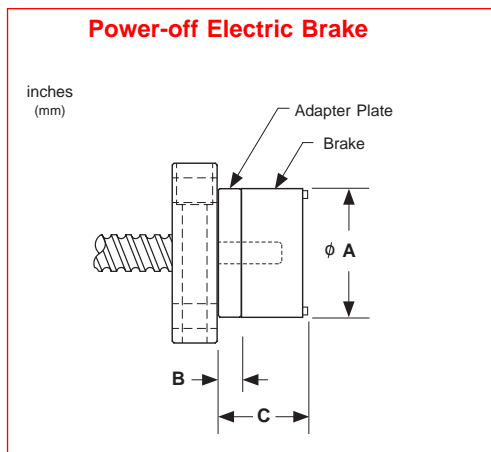

Screw Diameters	Brake Version	A in (mm)	B in (mm)	C in (mm)	Weight lbs (kgf)
0.500 to 0.750 inch 16 & 20 mm	B20 & B21	2.460 (62,48)	0.375 (9,52)	2.125 (53,97)	1.7 (0,77)
1.000 inch	B22 & B23	3.520 (89,41)	0.500 (12,70)	2.350 (59,69)	4.1 (1,86)
1.500 inch	B24 & B25	4.270 (108,46)	0.625 (15,87)	2.650 (67,31)	5.5 (2,49)

Power Supplies

Model Number	DC Output			AC Input		
	volts	amps	style	volts	amps	Hz
41970	5	3.0	regulated	120 / 240	0.8 / 0.4	47-63
37488	24	1.2	regulated	120 / 240	0.8 / 0.4	47-63
37489	90	0.8	unregulated	120	1.0	50/60
37490	90	0.8	unregulated	240	0.5	50/60

Sold & Serviced By:



Toll Free Phone (877) SERV098

Toll Free Fax (877) SERV099

www.electromate.com

sales@electromate.com

Specifications subject to change without notice