

14 **2** **4** **004** - **CP1** - **1** - **D1** - **M02** - **C155** - **L04** - **E00** - **B00**

Table Series

Number of Bearings

- 1** - 1 bearing per carriage
- 2** - 2 bearings per carriage

Carriage Length

- 4** - 4 inches

Travel Length (see pages B-24, B-26 & B-28)

- 004** - 4 to 120 inches

Cover Plate

- CP0** - no cover plate
- CP1** - top cover plate only
- CP2** - top & side cover plates

Carriage Inserts (see pages B-25, B-27 & B-29)

- 1** - English mount
- 2** - Metric mount

Drive Shaft (see pages B-25, B-27 & B-29)

- D1** - Right Hand single shaft
- D2** - Left Hand single shaft
- D3** - Right Hand thru shaft
- D4** - Left Hand thru shaft

Motor Mount (see pages B-25, B-27, B-29 & B-42)

- M00** - none
- M99** - other
- M02** - NEMA 23 mount (E)
- M03** - NEMA 23 mount (M)
- M04** - NEMA 34 mount (E)
- M05** - NEMA 34 mount (M)

Coupling Options (see pages B-38 & B-39)

- C000** - none
- C999** - none
- C130 to C134** - H100
- C155 to C164** - H131
- C190 to C200** - H163
- C407 to C413** - G100
- C435 to C444** - G126
- C470 to C480** - G158

Limit & Home Switches (see pages B-35 to B-37)

- | | | | | | |
|--------------------------|---------------------|------------|------------|------------|------------|
| L00 - no switches | | Reed | Hall | Prox (NPN) | Prox (PNP) |
| L99 - other | EOT & home switches | L04 | L07 | L10 | L13 |
| | EOT switches only | L05 | L08 | L11 | L14 |
| | home switch only | L06 | L09 | L12 | L15 |

Encoder Options (see page B-45)

- E00** - none
- E01** - rotary (500 lines/rev)
- E02** - rotary (1000 lines/rev)
- E03** - rotary (1270 lines/rev)
- E99** - other

note: When selecting any rotary encoder option, the Drive Shaft D3 or D4 above is required.

Power-off Brakes (see page B-44)

- B00** - none
- B01** - 24 VDC
- B02** - 90 VDC
- B99** - other

note: When selecting any brake option, the Drive Shaft D3 or D4 above is required.

(E) - English Interface
(M) - Metric Interface

Specifications

Load Capacities		One (1) Bearing Carriage	Two (2) Bearing Carriage
Dynamic Horizontal	2 million inches (50 km) of travel	100 lbs (45 kg)	200 lbs (90 kg)
Dynamic Horizontal	50 million inches (1270 km) of travel	34 lbs (15 kg)	68 lbs (30 kg)
Static Horizontal		200 lbs (90 kg)	400 lbs (180 kg)
Dynamic Roll Moment	2 million inches (50 km) of travel	8 ft-lbs (11 N-m)	16 ft-lbs (22 N-m)
Dynamic Roll Moment	50 million inches (1270 km) of travel	3 ft-lbs (4 N-m)	5 ft-lbs (7 N-m)
Static Roll Moment		14 ft-lbs (19 N-m)	28 ft-lbs (38 N-m)
Dyn. Pitch & Yaw Moment	2 million inches (50 km) of travel	4 ft-lbs (5,4 N-m)	15 ft-lbs (20 N-m)
Dyn. Pitch & Yaw Moment	50 million inches (1270 km) of travel	1 ft-lbs (1,9 N-m)	5 ft-lbs (7 N-m)
Static Pitch & Yaw Moment		8 ft-lbs (10 N-m)	30 ft-lbs (40 N-m)
Each Bearing Dyn. Capacity	2 million inches (50 km) of travel	100 lbs (45 kg)	100 lbs (45 kg)
Each Bearing Dyn. Capacity	50 million inches (1270 km) of travel	34 lbs (15 kg)	34 lbs (15 kg)
Each Bearing Static Load Capacity		200 lbs (90 kg)	200 lbs (90 kg)
Maximum Belt Tensile Force		250 lbs (113 kg)	250 lbs (113 kg)
Maximum Carriage Thrust Force		115 lbs (52 kg)	115 lbs (52 kg)
Maximum Speed		78 in/sec (2 m/sec)	78 in/sec (2 m/sec)
Maximum Acceleration		193 in/sec ² (4,9 m/sec ²)	386 in/sec ² (9,8 m/sec ²)
d₂	Center to center distance (spacing) of each bearing on a single rail	-	2.088 in (53,0 mm)
d_r	Center distance of the bearing to top of carriage plate surface	1.375 in (34,9 mm)	1.375 in (34,9 mm)

Other	For One (1) & Two (2) Bearing Carriages
Table Material	Base, Carriage, End Plates, & Cover Plate - 6061 anodized aluminum
Linear Rail Material	Stainless Steel
Belt Properties	Black, 16 mm wide, Polyurethane, Steel reinforced belt
Drive Pulley Weight	0.21 lbs (0,10 kg)
Drive Pulley Diameter	1.128 in (28,65 mm)
Drive Lead	3.543 in (90,00 mm)
Belt Stretch - x Load (lbs or N)	0.00025 in/ft per lbs (0,00476 mm/m per N)
Unidirectional Repeatability	+/- 0.001 in (+/- 0,0254 mm)
Bidirectional Repeatability	+/- 0.004 in (+/- 0,1016 mm)
Position Accuracy (Belt) ⁽¹⁾	< 0.010 in/ft (< 0,254 mm/300mm)
Orthogonality (multi-axis systems)	< 30 arc-seconds
Friction Coefficient	< 0.01
Breakaway Torque	< 40 oz-in (0,282 N-m)
Motor Mount	NEMA 23 & 34 Mounts, Metric Mounts, and Gearheads
Coupling	Two (2) different styles available

Sold & Serviced By:

 Toll Free Phone (877) SERV098
 Toll Free Fax (877) SERV099
www.electromate.com
sales@electromate.com

Footnotes:

(1) Position accuracy varies based on belt stretch. The given rating is based upon a carriage speed of 5 inches/sec (127 mm/sec) and a no load condition.

Dimensions & Specifications

- Without Cover Plates -

Model Number	Travel Length inches (mm)	Table Dimensions inches (mm)		Mounting Dimensions inches (mm)			Belt Weight ounces (gm)	Table Weight ⁽¹⁾ lbs (kg)
		A	B	C	E	M		
14x4004-CP0	4 (100)	8.0 (203,2)	14.0 (355,6)	1.188 (30,2)	3	8	1.3 (36,8)	4.8 (2,2)
14x4006-CP0	6 (150)	10.0 (254,0)	16.0 (406,4)	0.313 (8,0)	5	12	1.5 (42,5)	5.3 (2,4)
14x4008-CP0	8 (200)	12.0 (304,8)	18.0 (457,2)	1.313 (33,4)	5	12	1.7 (48,2)	5.8 (2,6)
14x4012-CP0	12 (300)	16.0 (406,4)	22.0 (558,8)	1.438 (36,5)	7	16	2.1 (59,5)	6.3 (2,9)
14x4016-CP0	16 (405)	20.0 (508,0)	26.0 (660,4)	1.563 (39,7)	9	20	2.5 (70,9)	7.3 (3,3)
14x4020-CP0	20 (505)	24.0 (609,6)	30.0 (762,0)	1.688 (42,9)	11	24	2.9 (82,2)	8.3 (3,8)
14x4024-CP0	24 (605)	28.0 (711,2)	34.0 (863,6)	1.813 (46,1)	13	28	3.3 (93,6)	9.3 (4,2)
14x4030-CP0	30 (760)	34.0 (863,6)	40.0 (1016,0)	1.063 (27,0)	17	36	3.9 (110,6)	10.3 (4,7)
14x4036-CP0	36 (910)	40.0 (1016,0)	46.0 (1168,4)	0.313 (8,0)	21	44	4.5 (127,6)	11.8 (5,4)
14x4042-CP0	42 (1060)	46.0 (1168,4)	52.0 (1320,8)	1.438 (36,5)	23	48	5.1 (144,6)	13.3 (6,0)
14x4048-CP0	48 (1215)	52.0 (1320,8)	58.0 (1473,2)	0.688 (17,5)	27	56	5.7 (161,6)	14.8 (6,7)
14x4054-CP0	54 (1370)	58.0 (1473,2)	64.0 (1625,6)	1.813 (46,1)	29	60	6.3 (178,6)	16.3 (7,4)
14x4060-CP0	60 (1520)	64.0 (1625,6)	70.0 (1778,0)	1.063 (27,0)	33	68	6.9 (195,6)	17.8 (8,1)
14x4072-CP0	72 (1820)	76.0 (1930,4)	82.0 (2082,8)	0.500 (12,7)	39	80	8.1 (229,6)	20.8 (9,4)
14x4084-CP0	84 (2130)	88.0 (2235,2)	94.0 (2387,6)	0.875 (22,2)	45	92	9.3 (263,7)	23.8 (10,8)
14x4096-CP0	96 (2435)	100.0 (2540,0)	106.0 (2692,4)	0.313 (8,0)	51	104	10.5 (297,7)	26.8 (12,2)
14x4108-CP0	108 (2740)	112.0 (2844,8)	118.0 (2997,2)	0.688 (17,5)	57	116	11.7 (331,7)	29.8 (13,5)
14x4120-CP0	120 (3045)	124.0 (3149,6)	130.0 (3302,0)	1.063 (27,0)	63	128	12.9 (365,7)	32.8 (14,9)

{

 x = 1; Carriage has 1 bearing; Carriage weight = 1.4 lbs. (0,64 kg)
 x = 2; Carriage has 2 bearings; Carriage weight = 1.5 lbs. (0,68 kg)

Footnotes:

(1) Weight shown is with a 1 bearing carriage [1.4 lbs (0,64 kg)], a NEMA 23 motor mount [0.34 lbs (0,16 kg)], and a H100 style [0.08 lbs (0,04 kg)] coupling. When using a 2 bearing carriage add 0.1 lbs (0,04 kg) to each value.

Sold & Serviced By:

 Toll Free Phone (877) SERV098
 Toll Free Fax (877) SERV099
www.electromate.com
sales@electromate.com

Dimensions

- Without Cover Plates -

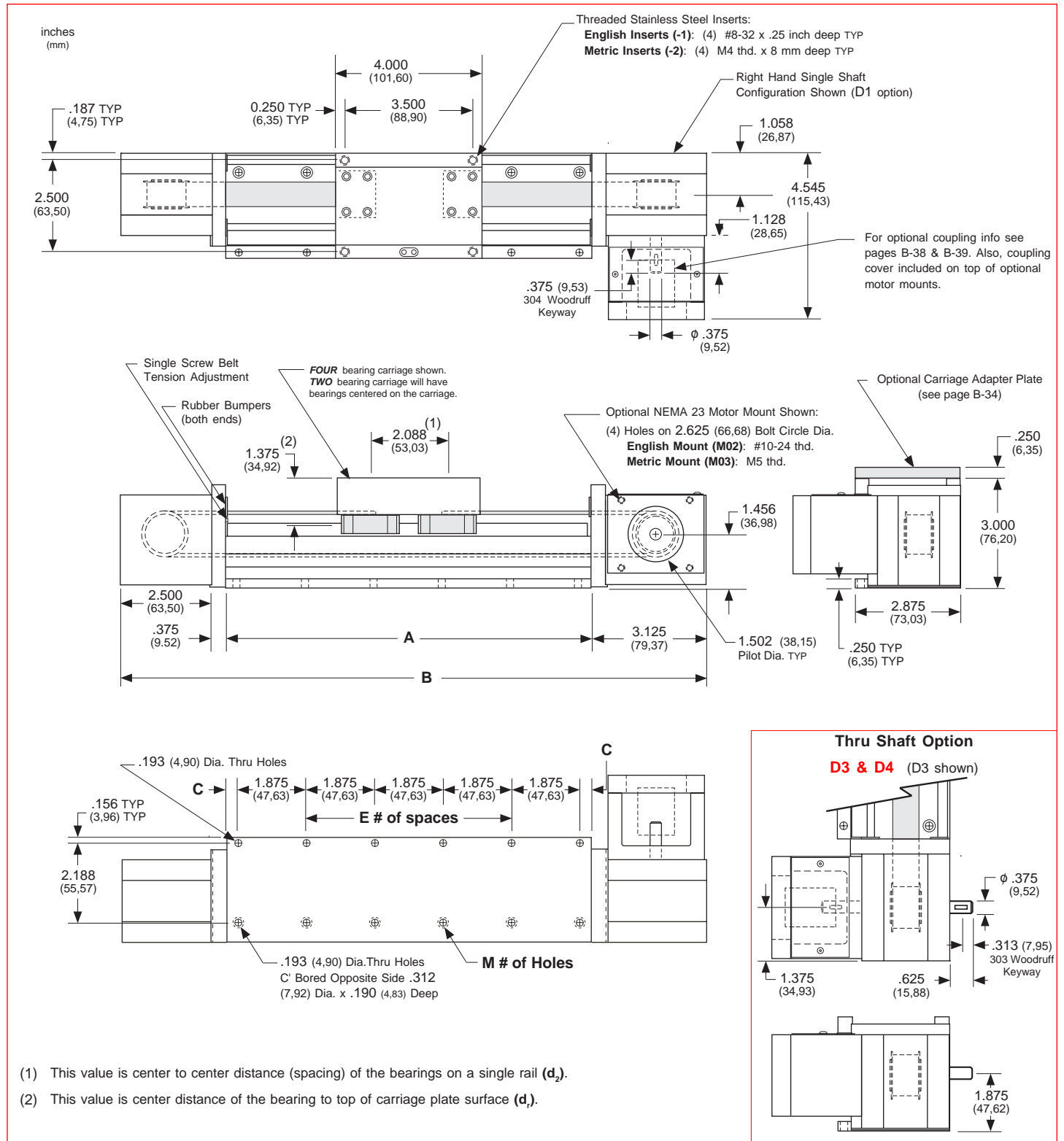

Note: Any 130 or 140 series table can be mounted on top of a second 130 or 140 series table, in order to create X-Y multiple axis configurations. **LINTECH** recommends that a 2 bearing carriage be used for the bottom axis, and that the top axis should never extend out more than 18 inches in either direction, from the bottom axis carriage edge, without the use of a support bearing system on the outer edges of the top axis. The 130-CP1, 130-CP2 or 140 series requires a **Carriage Adapter Plate** option. The carriage's threaded stainless steel insert hole pattern exactly matches the base mounting hole pattern on each table, therefore no adapter bracket or extra machining is required. However a precision square tool, or micrometer depth gauge, is required in order to obtain an orthogonality between the two tables of < 30 arc-seconds. The table base, carriage top & carriage sides are all precision machined. **LINTECH's** 100 or 120 series tables should be used for the bottom axis in a multiple axes application for better system rigidity, performance, and life.

Dimensions & Specifications

- With Top Cover Plate Only -

Model Number	Travel Length inches (mm)	Table Dimensions inches (mm)		Mounting Dimensions inches (mm)			Belt Weight ounces (gm)	Table Weight ⁽¹⁾ lbs (kg)
		A	B	C	E	M		
14x4004-CP1	4 (100)	8.0 (203,2)	14.0 (355,6)	1.188 (30,2)	3	8	1.3 (36,8)	4.8 (2,2)
14x4006-CP1	6 (150)	10.0 (254,0)	16.0 (406,4)	0.313 (8,0)	5	12	1.5 (42,5)	5.3 (2,4)
14x4008-CP1	8 (200)	12.0 (304,8)	18.0 (457,2)	1.313 (33,4)	5	12	1.7 (48,2)	5.8 (2,6)
14x4012-CP1	12 (300)	16.0 (406,4)	22.0 (558,8)	1.438 (36,5)	7	16	2.1 (59,5)	6.3 (2,9)
14x4016-CP1	16 (405)	20.0 (508,0)	26.0 (660,4)	1.563 (39,7)	9	20	2.5 (70,9)	7.3 (3,3)
14x4020-CP1	20 (505)	24.0 (609,6)	30.0 (762,0)	1.688 (42,9)	11	24	2.9 (82,2)	8.3 (3,8)
14x4024-CP1	24 (605)	28.0 (711,2)	34.0 (863,6)	1.813 (46,1)	13	28	3.3 (93,6)	9.3 (4,2)
14x4030-CP1	30 (760)	34.0 (863,6)	40.0 (1016,0)	1.063 (27,0)	17	36	3.9 (110,6)	10.3 (4,7)
14x4036-CP1	36 (910)	40.0 (1016,0)	46.0 (1168,4)	0.313 (8,0)	21	44	4.5 (127,6)	11.8 (5,4)
14x4042-CP1	42 (1060)	46.0 (1168,4)	52.0 (1320,8)	1.438 (36,5)	23	48	5.1 (144,6)	13.3 (6,0)
14x4048-CP1	48 (1215)	52.0 (1320,8)	58.0 (1473,2)	0.688 (17,5)	27	56	5.7 (161,6)	14.8 (6,7)
14x4054-CP1	54 (1370)	58.0 (1473,2)	64.0 (1625,6)	1.813 (46,1)	29	60	6.3 (178,6)	16.3 (7,4)
14x4060-CP1	60 (1520)	64.0 (1625,6)	70.0 (1778,0)	1.063 (27,0)	33	68	6.9 (195,6)	17.8 (8,1)

- x = 1; Carriage has 1 bearing; Carriage weight = 1.4 lbs. (0,64 kg)
- x = 2; Carriage has 2 bearings; Carriage weight = 1.5 lbs. (0,68 kg)

Footnotes:

(1) Weight shown is with a 1 bearing carriage [1.4 lbs (0,64 kg)], a NEMA 23 motor mount [0.34 lbs (0,16 kg)], and a H100 style [0.08 lbs (0,04 kg)] coupling. When using a 2 bearing carriage add 0.1 lbs (0,04 kg) to each value.

Dimensions

- With Top Cover Plate Only -

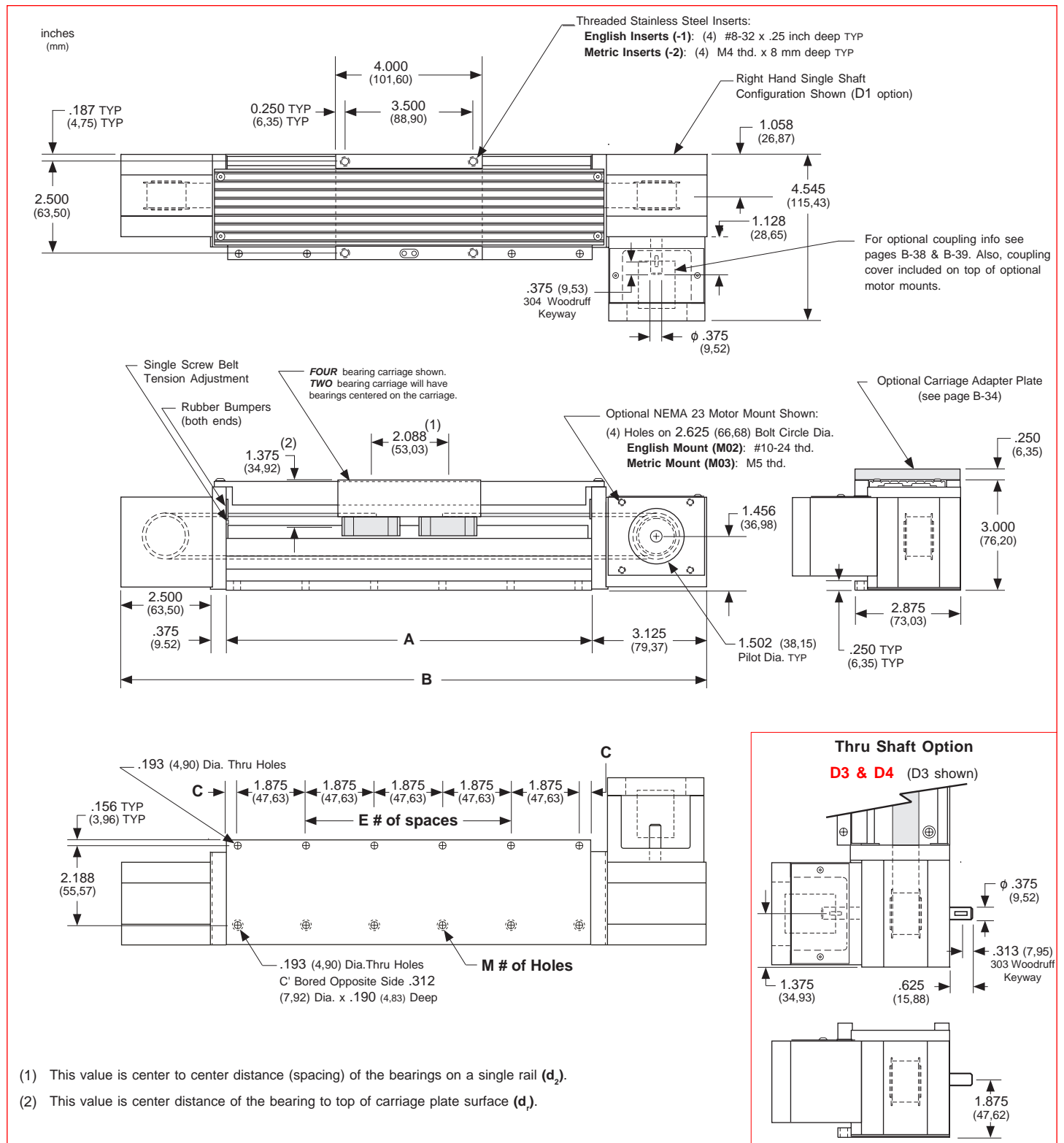

Note: Any 130 or 140 series table can be mounted on top of a second 130 or 140 series table, in order to create X-Y multiple axis configurations. **LINTECH** recommends that a 2 bearing carriage be used for the bottom axis, and that the top axis should never extend out more than 18 inches in either direction, from the bottom axis carriage edge, without the use of a support bearing system on the outer edges of the top axis. The 130-CP1, 130-CP2 or 140 series requires a **Carriage Adapter Plate** option. The carriage's threaded stainless steel insert hole pattern exactly matches the base mounting hole pattern on each table, therefore no adapter bracket or extra machining is required. However a precision square tool, or micrometer depth gauge, is required in order to obtain an orthogonality between the two tables of < 30 arc-seconds. The table base, carriage top & carriage sides are all precision machined. **LINTECH's** 100 or 120 series tables should be used for the bottom axis in a multiple axes application for better system rigidity, performance, and life.

Dimensions & Specifications

- With Top Cover Plate Only -

Model Number	Travel Length inches (mm)	Table Dimensions inches (mm)		Mounting Dimensions inches (mm)			Belt Weight ounces (gm)	Table Weight ⁽¹⁾ lbs (kg)
		A	B	C	E	M		
14x4004-CP2	4 (100)	8.0 (203,2)	14.0 (355,6)	1.188 (30,2)	3	8	1.3 (36,8)	5.0 (2,3)
14x4006-CP2	6 (150)	10.0 (254,0)	16.0 (406,4)	0.313 (8,0)	5	12	1.5 (42,5)	5.5 (2,5)
14x4008-CP2	8 (200)	12.0 (304,8)	18.0 (457,2)	1.313 (33,4)	5	12	1.7 (48,2)	6.0 (2,7)
14x4012-CP2	12 (300)	16.0 (406,4)	22.0 (558,8)	1.438 (36,5)	7	16	2.1 (59,5)	6.6 (3,0)
14x4016-CP2	16 (405)	20.0 (508,0)	26.0 (660,4)	1.563 (39,7)	9	20	2.5 (70,9)	7.7 (3,5)
14x4020-CP2	20 (505)	24.0 (609,6)	30.0 (762,0)	1.688 (42,9)	11	24	2.9 (82,2)	8.7 (3,9)
14x4024-CP2	24 (605)	28.0 (711,2)	34.0 (863,6)	1.813 (46,1)	13	28	3.3 (93,6)	9.8 (4,5)
14x4030-CP2	30 (760)	34.0 (863,6)	40.0 (1016,0)	1.063 (27,0)	17	36	3.9 (110,6)	10.9 (5,0)
14x4036-CP2	36 (910)	40.0 (1016,0)	46.0 (1168,4)	0.313 (8,0)	21	44	4.5 (127,6)	12.5 (5,7)
14x4042-CP2	42 (1060)	46.0 (1168,4)	52.0 (1320,8)	1.438 (36,5)	23	48	5.1 (144,6)	14.0 (6,4)
14x4048-CP2	48 (1215)	52.0 (1320,8)	58.0 (1473,2)	0.688 (17,5)	27	56	5.7 (161,6)	15.6 (7,1)
14x4054-CP2	54 (1370)	58.0 (1473,2)	64.0 (1625,6)	1.813 (46,1)	29	60	6.3 (178,6)	17.2 (7,8)
14x4060-CP2	60 (1520)	64.0 (1625,6)	70.0 (1778,0)	1.063 (27,0)	33	68	6.9 (195,6)	18.8 (8,5)

- x = 1; Carriage has 1 bearing; Carriage weight = 1.4 lbs. (0,64 kg)
- x = 2; Carriage has 2 bearings; Carriage weight = 1.5 lbs. (0,68 kg)

Footnotes:

(1) Weight shown is with a 1 bearing carriage [1.4 lbs (0,64 kg)], a NEMA 23 motor mount [0.34 lbs (0,16 kg)], and a H100 style [0.08 lbs (0,04 kg)] coupling. When using a 2 bearing carriage add 0.1 lbs (0,04 kg) to each value.

Dimensions

- With Top Cover Plate Only -

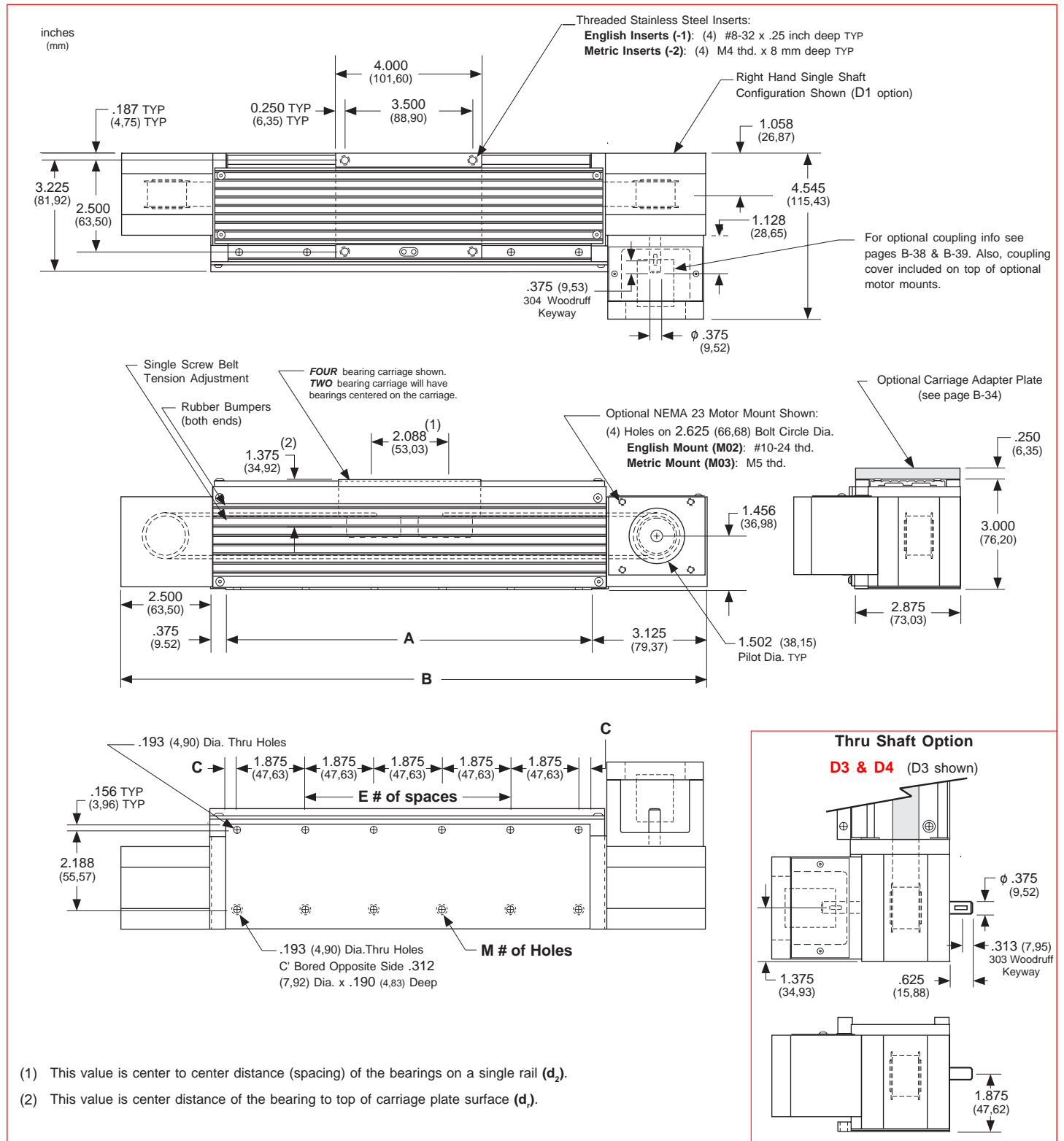

Note: Any 130 or 140 series table can be mounted on top of a second 130 or 140 series table, in order to create X-Y multiple axis configurations. **LINTECH** recommends that a 2 bearing carriage be used for the bottom axis, and that the top axis should never extend out more than 18 inches in either direction, from the bottom axis carriage edge, without the use of a support bearing system on the outer edges of the top axis. The 130-CP1, 130-CP2 or 140 series requires a **Carriage Adapter Plate** option. The carriage's threaded stainless steel insert hole pattern exactly matches the base mounting hole pattern on each table, therefore no adapter bracket or extra machining is required. However a precision square tool, or micrometer depth gauge, is required in order to obtain an orthogonality between the two tables of < 30 arc-seconds. The table base, carriage top & carriage sides are all precision machined. **LINTECH's** 100 or 120 series tables should be used for the bottom axis in a multiple axes application for better system rigidity, performance, and life.