

Kollmorgen Stepper Solutions Catalog

including AC Synchronous Motors

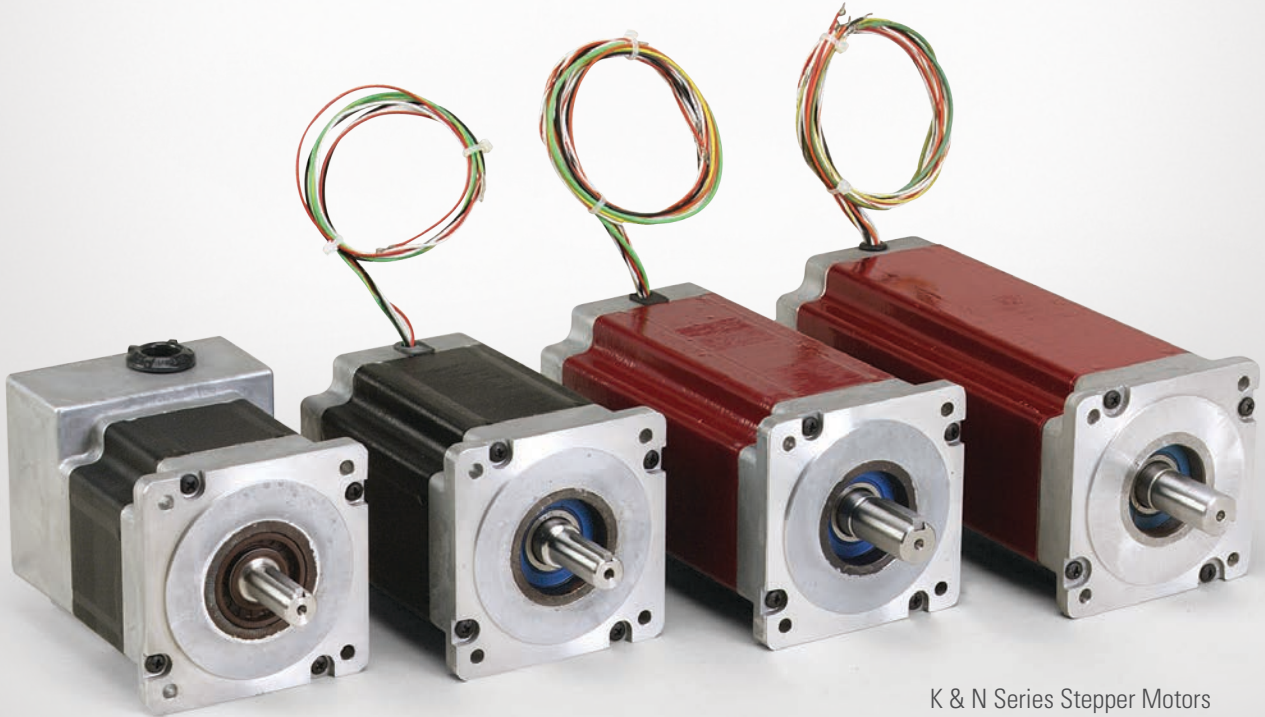

K & N Series Stepper Motors

Kollmorgen. Every solution comes from a real understanding of OEM challenges.

The ever-escalating demands of the marketplace mean increased pressure on OEMs at every turn. Time constraints. Demands for better performance. Having to think about the next-generation machine even before the current one is built. While expectations are enormous, budgets are not. Kollmorgen's innovative motion solutions and broad range of quality products help engineers not only overcome these challenges but also build truly differentiated machines.

Because motion matters, it's our focus. Motion can distinctly differentiate a machine and deliver a marketplace advantage by improving its performance. This translates to overall increased efficiency for your application. Perfectly deployed machine motion can make your customer's machine more reliable and efficient, enhance accuracy and improve operator safety. Motion also represents endless possibilities for innovation. We've always understood this potential, and thus have kept motion at our core, relentlessly developing products that offer precision control of speed, accuracy and position in machines that rely on complex motion.

Table of Contents

▶ Stepper Motors	4	▶ MX9 Series Stepper Motors	84
Hybrid Motor Technology	6	MX9 Series General Specifications	84
Basic Stepper Motor Operation	7	MX9 Outline Drawings and Performance Data	85
Holding Torque	7	▶ MX11 Series Stepper Motors	86
▶ Stepper Positioning Drive Controllers	8	MX11 Series General Specifications and Outline Drawings	86
P5000 Drive	10	MX11 Performance Data	87
P6000 Drive	12	▶ Stepper Motor Connection Information	88
P7000 Drive	14	CT, K&N, E&H, T2, MH172, MX Connection Information	88
▶ Stepper Motor Performance Summary	18	M/P Connection Information	91
▶ CTP/CTM Series Stepper Motor Overview	20	Phase Sequencing Table	93
▶ CTP/CTM Series Stepper Motors	22	▶ X-TRUE Planetary Gearhead	94
CTP/CTM Series General Specifications	22	Outline Drawings, Dimensions, and Specifications	96
CTP1, CTP2/CTM2, CTP3/CTM3 Outline Drawings	23	Performance Data	97
CTP1 Performance Data and Curves	25	Radial and Axial Load Ratings	99
CTP2/CTM2 Performance Data and Curves	27	▶ Stepper Motor Application Worksheet	100
CTP3/CTM3 Performance Data and Curves	32	▶ AC Synchronous Motors	102
▶ T2 Series Stepper Motors	38	AC Synchronous Motor Technology	104
T2 Series General Specifications	38	▶ AC Synchronous Motor Performance Summary	106
T2 Outline Drawings	39	▶ KSL06 Series AC Synchronous Motors	108
T2 Performance Data and Curves	40	KSL06 Series General Specifications and Outline Drawings	108
▶ M2/P2 Series Stepper Motors	42	KSL06 Performance Data	109
M2/P2 Series General Specifications	42	▶ SS Series AC Synchronous Motors	110
M2/P2 Outline Drawings	43	SS Series General Specifications	110
M2/P2 Performance Data and Curves	44	SS24x, 54x Outline Drawings	110
▶ K/N Series Stepper Motors	50	SS15x, 25x, 40x, 70x Outline Drawings	111
K/N Series General Specifications	50	SS1800 Outline Drawings	112
K3/N3 and K4/N4 Outline Drawings	51	SS24x, 54x Performance Data	113
K3/N3 Performance Data and Curves	56	SS15x, 25x, 40x, 70x Performance Data	114
K4/N4 Performance Data and Curves	62	SS1800 Performance Data	115
▶ E/H Series Stepper Motors	66	▶ X(CE) Series AC Synchronous Motors	116
E/H Series General Specifications	66	X(CE) Series General Specifications	116
E2/H2, E3/H3, and E4/H4 Outline Drawings	67	X(CE) 25x/70., 1100/1500 Outline Drawings	117
E2/H2 Performance Data and Curves	73	X(CE) 25x/70., 1100/1500 Performance Data	119
E3/H3 Performance Data and Curves	76	▶ AC Synchronous Gearmotors and Gearbox Kits	120
E4/H4 Performance Data and Curves	80	▶ AC Synchronous Connection Diagrams	123
▶ MH172 Series Stepper Motors	82	▶ AC Synchronous Motor Application Guide	124
MH172 Series General Specifications and Outline Drawings	82	▶ Optimized Solutions	126
MH172 Performance Data and Curves	83	▶ Model Nomenclature	130
		▶ MOTIONEERING® Application Engine	145

Stepper Motors

Kollmorgen's stepper motors are designed with versatility, ease-of-use, and cost-effectiveness in mind. They provide high torque in a small package and come in a wide range of standard sizes, constructions, windings and options.

Our high-performance, brushless, maintenance-free stepper motors provide very precise, extremely cost-effective motion control. These 2 phase stepper motors inherently move in small, very precise, 1.8° increments (200 steps/revolution). This stepping action is simple to control and does not require complicated, expensive feedback devices.

They are available with custom leads, shafts and connectors are routinely provided to effectively solve your application needs. Several models feature the addition of our innovative SIGMAX® technology for higher torque and acceleration rates.

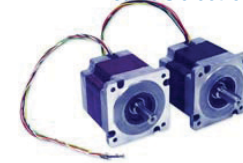

The Benefits of Stepper Motors

- Our stepper motors provide high torque in a small package. They offer a wide range of standard sizes, constructions, windings and options. Custom leads, shafts and connectors are routinely provided to effectively solve your application needs.
- 7 series in 5 frame sizes: NEMA 17, 23, 34, 42, 66
- Models available with SIGMAX technology and high torque construction for maximum torque in the smallest package size
- Holding torques from 33 - 6130 oz-in (0.23 - 43.3 Nm) to accommodate a wide range of applications
- Speeds to 3,000 rpm to meet all low and medium speed applications
- Choice of standard connection methods and IP ratings to meet environmental conditions of the application including:
 - integral connector
 - leads
 - terminal box
- All models are CE compliant
- Special modifications readily available: shafts, leads, connectors, etc.

Model	NEMA	Sizes	Holding Torque oz-in (Nm)	SIGMAX®* Technology	Family Features	Standard Options
CTP1 Series	17	3	33 - 80 (0.23 - 0.56)		High Torque standard (P) hybrid stepper motor Enhanced (M) hybrid stepper motor Low Cost High Volume Minimum Quantities	L, RS
CTM2 Series	23	2	200 - 470 (1.4 - 3.3)	•		
CTP2 Series	23	3	75 - 360 (0.53 - 2.5)			
CTM3 Series	34	3	550 - 1930 (3.9 - 13.6)	•		
CTP3 Series	34	3	450 - 1570 (3.18 - 11.1)			
T2 Series	23	4	74 - 380 (0.52 - 2.68)		High torque standard hybrid stepper motor	L, T, MS, E, RS
M2 Series	23	2	95 - 253 (0.67 - 1.79)	•	Standard (P) hybrid stepper motor Enhanced (M) hybrid stepper motor	IC, L, E, RS, J
P2 Series	23	3	42 - 214 (0.30 - 1.51)			
K3 Series	34	4	590 - 2790 (4.17 - 19.7)	•	Standard (N) hybrid stepper motor Enhanced (K) hybrid step motors	L, T, MS, E, RS
N3 Series	34	4	460 - 2180 (3.25 - 15.4)			
K4 Series	42	3	1510 - 5660 (10.7 - 46.3)	•		
N4 Series	42	3	1150 - 4370 (8.12 - 30.9)			
E2 Series	23	2	85 - 225 (0.60 - 1.59)	•	Standard (H) round frame steppers, low loss, high torque over wide speed range Enhanced (E) standard round frame steppers, low loss, high torque over wide speed range	L, MS, E, RS, J(H2)
H2 Series	23	3	36 - 158 (0.25 - 1.12)			
E3 Series	34	4	223 - 1300 (1.58 - 9.18)	•		L, MS, E, RS
H3 Series	34	4	158 - 916 (1.21 - 6.47)			
E4 Series	42	3	957 - 3960 (6.76 - 28.0)	•		
H4 Series	42	3	585 - 2650 (4.13 - 18.7)			
MH172	66	1	6120 (42.2)		Standard hybrid stepper motor	RS, E
MX9	34	3	180 - 550 (1.27 - 3.88)		Standard hybrid stepper motor Explosion proof UL Class1, Div. 1 Group D	RS
MX11	42	2	850 - 1390 (6.0 - 9.82)			

*Enhanced SIGMAX technology motors have stator mounted magnets that concentrate flux producing higher torque and better current utilization
Standard Options: IC - Integral Connector; L - Leaded; T - Terminal Box; MS - MS Connector; E - Encoders; RS - Rear Shaft; J - low inertia

Stepper Motors

Hybrid Stepper Motor Technology

Kollmorgen motors utilize high torque magnetic designs that feature a large rotor diameter, small air gap, high energy rotor magnets and windings. This provides maximum torque in the smallest package.

- Lower Energy Usage
- Faster Machines
- Lower System Cost
- More Compact Machines

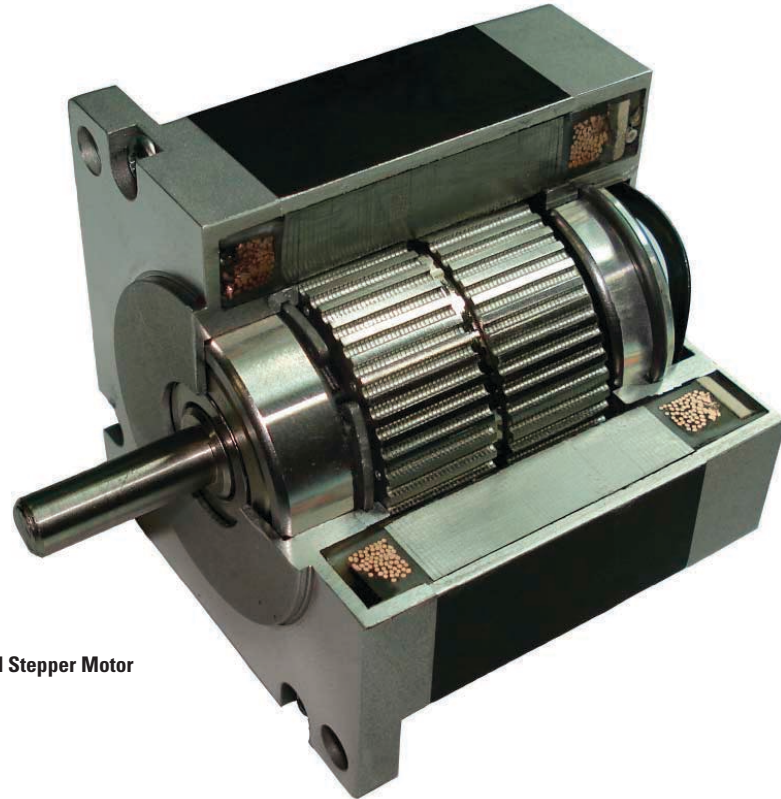

Kollmorgen Hybrid Stepper Motor

High Voltage Insulation

Inset molded insulation system encases the stator, eliminating joints and gaps that can fail. Reliability and voltage ratings are increased. Kollmorgen motors can be used with all standard drives, as well as high voltage high performance drives.

- Faster design cycles knowing Kollmorgen motors work with all drives.
- Higher reliability

Large Bearing System

To accommodate high thrust loads and high side loading, many motors feature large bearings.

- Lower machine costs. Loads can be directly mounted on motor shaft eliminating couplings and load support bearings.
- Excellent for leadscrew applications
- Longer life

Basic Stepper Motor Operation

Kollmorgen Hybrid stepper motors have two windings (two phases) that are energized with DC current. When the current in one winding is reversed, the motor shaft moves one step, or 1.8°. By reversing the current in each winding the position and speed of the motor is easily and precisely controlled, making these motors extremely useful for many different motion control applications.

For even finer resolution and smoother operation, micro-stepping drives divide each step into many increments by controlling the magnitude of the current in each winding.

The performance of hybrid stepper motors is highly dependent on the current and voltage supplied by a drive. Kollmorgen stepper motors are available with a variety of windings so they can be used with drives that have a broad range of voltage and current ratings. Performance curves are included in this catalog for many common motor drive combinations.

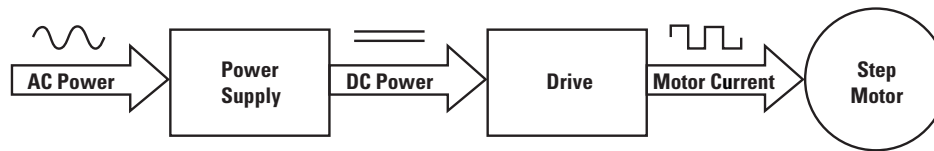

Holding Torque

Because motor performance at speed varies greatly with the drive, holding torque is used to rate hybrid stepper motors. Holding torque specifies the maximum torque that can be applied to a motor shaft and not cause the shaft to rotate. It is measured with the motor at standstill and energized with rated DC current. Since the motor is energized with pure DC current, holding torque is not dependent on specific drive characteristics.

SIGMAX® Technology

- Smaller drives = Lower system cost
- More torque = Smaller, faster machines
- Higher efficiency = Lower operating costs

Through the use of enhancing technology, Kollmorgen stepper motors provide the maximum performance available. This patented technology boosts torque an additional 25% across the entire speed range and allows machines to be designed that are smaller and move faster.

Initial system costs are often less with enhanced motors because the additional torque is produced without the need for larger drives or power supplies. The additional output power is produced through higher efficiency. The higher efficiency reduces energy usage by 25% and lowers operating costs.

SIGMAX® motors use additional magnets inserted between each stator tooth. These magnets block the magnet fields from flowing around the stator teeth. This forces more of the magnetic field to flow through each tooth where it produces torque.

Standard Stepper Motor

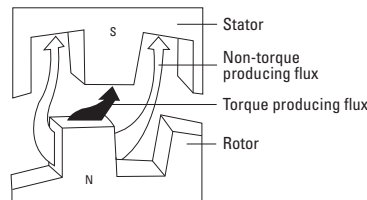

Typical paths of flux transfer in an energized conventional hybrid stepper motor. Some flux leakage occurs in normal operation.

Enhanced Stepper Motor

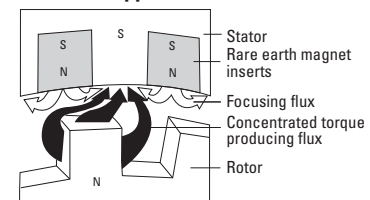

Patented enhancing technology redirects magnetic flux to inhibit leakage and optimize torque production.

Stepper Positioning Drives

Kollmorgen's stepper drives are designed with versatility, ease-of-use, and cost-effectiveness in mind. Choose from a broad range of advanced drives and controls including full, half, and microstepping models in both modular and packaged designs.

Modular drives are open-frame units or have small enclosures, and require an external DC power source. They are generally used where the drive will become an integral part of the user's system or in multiaxis systems utilizing a common power supply.

A packaged drive is a stand-alone unit that operates directly from an AC power source and is packaged in a full enclosure.

P-Series Drive Features and Benefits

P - S E R I E S D R I V E F E A T U R E S A N D B E N E F I T S

P5000



Value DC Input Stepper Drive

- Wave matching for Kollmorgen motors to provide optimal performance
- All inputs and outputs are optically isolated
- Step and direction inputs or internal velocity controlled oscillator (VCO) dip switch selectable
- DIP switch selectable micro-stepping resolution settings
- Idle current reduction, DIP switch selectable
- Compensation for mid-range instability
- RoHS & CE certified
- UL pending

P6000



Full Featured AC Input Stepper Drive

- No programming required
- Covers full power range of Kollmorgen steppers
- Switch selectable current from 0.2-5.7 Arms, 8.0 A peak
- Switch selectable for many Kollmorgen motor pairings
- All inputs and outputs are optically isolated
- Single-ended and differential step and direction
- Enable input
- Switch selectable micro-stepping resolution
- Anti-resonance based on load inertia
- RoHS & CE certified

P7000



Full Featured AC or DC Input Stepper Drives with Intelligent Indexing Option (-PN)

- AC and DC input versions
- Covers full power range of Kollmorgen steppers
- Drives can be configured by either dip switches or P7000 software
- Intelligent indexing option (-PN) provides ability to link motion tasks.
- All inputs and outputs are optically isolated
- Single-ended and differential step and direction
- Enable input
- Switch selectable micro-stepping resolution
- Anti-resonance based on load inertia
- RoHS, CE and UL certified

Budget/Value

Full-Featured

STEPPER DRIVE PRODUCT OVERVIEW

Stepper Drive Model	Modes of Operation*	Input voltage (Vdc)	Input Voltage (Vac)	Output current (A dc) Continuous (Peak)
P5000	S, V	20 - 75	n/a	0.7 - 2.0 {3.5}
P6000	S	n/a	110-240 +/-10%	0.3 - 5.7 {8.0}
P70530	S, M	20 - 75	n/a	0 - 5.0 {7.1}
P70360	S, M	n/a	120/240	0 - 2.5 {3.5}

Modes of Operation: S - Step and Direction; V - Velocity Controlled Oscillator (VCO);
M - Motion Node Indexing

P5000 Stepper Drive-Controller

P 5 0 0 0 S T E P P E R D R I V E - C O N T R O L L E R

Big Performance, Micro Package.

Introducing the New Kollmorgen P5000 Stepper Drive.

The P5000 is a compact micro-stepping stepper drive optimized for high system performance with Kollmorgen's industry leading POWERMAX II stepper motors. It is an impressive yet simple addition to the Kollmorgen stepper drive family.

Optimized. Smooth. Compact.

Pairing a stepper system doesn't get any easier! The P5000 and Kollmorgen stepper motors are meant to be together. With Kollmorgen motor windings optimized for the P5000, all you have to do is set the dip switches for the motor you are paired with and you have a smooth operating system that fully utilizes the potential of your Kollmorgen motor and drive combination!

Features

- Current output from 0.7-3.5 Arms peak; DIP switch selectable in 0.2 Amp increments
- Bus Voltage 20-75 Vdc
- Wave matching for Kollmorgen motors to provide optimal performance for the Kollmorgen Stepper Motor Families.
- All Inputs and Outputs are Optically Isolated
- Command Source from External Step and Direction Inputs or Internal Velocity Controlled Oscillator (VCO); DIP switch selectable
- External Single-Ended Step and Direction Command
 - Disable or Fault Reset Input
 - Fault or Enable Output
- VCO Mode
 - CW Limit Input
 - CCW Limit Input
 - Run/Stop Input
 - Run/Stop Output
 - CW Speed trimpot
 - CCW Speed trimpot
 - Accel/Decel trimpot
- DIP switch selectable micro-stepping-resolution settings
- Pulse Multiplier smooths micro-stepping*
- Idle Current Reduction; DIP switch selectable
- Compensation for mid-range instability*
- RoHS & CE certified
- UL pending



P5000 Stepper Drive
(Shown Actual Size)



*Patents Pending

P5000 Drive-Controller Outline Drawings with Dimensions

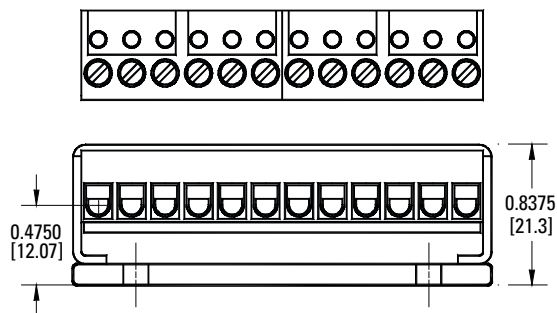
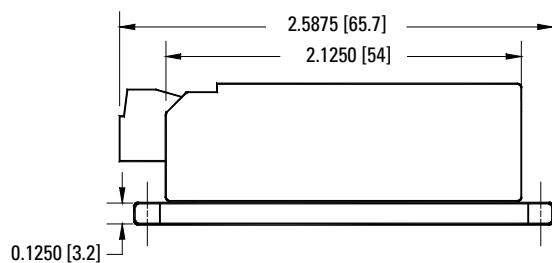
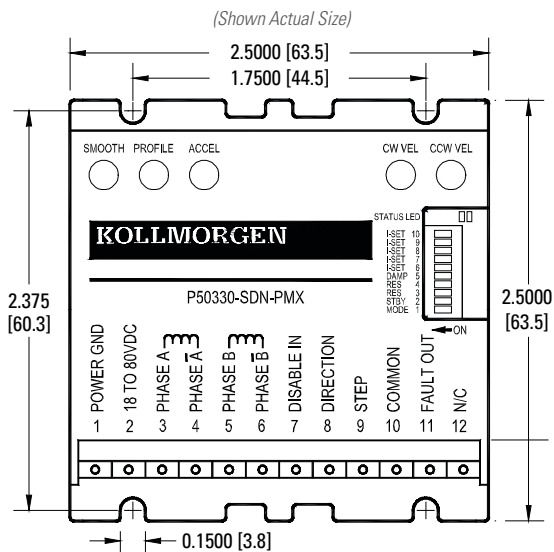
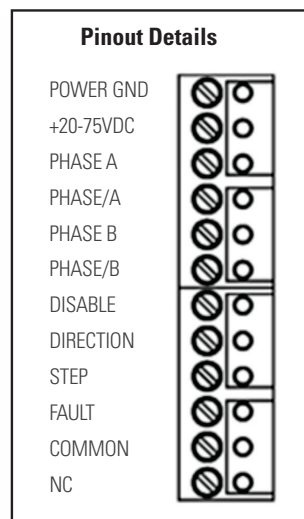

Dimensions in inches [mm]

P6000 Stepper Drive-Controller

Powerful, Yet Simple.

Introducing the New Kollmorgen P6000 Stepper Drive.

The P6000 is an AC input micro-stepping drive optimized for pairing with POWERPAC and POWERMAX stepper motors. With the simplicity of dip switches and the optimized performance from the complete system, this stepper solution brings increased machine performance without the associated complexity.

Powerful. Simple. Optimized.

The P6000 and Kollmorgen POWERPAC and POWERMAX stepper motors are designed to provide the best system solution when paired with one another. The easy dip switch selection matches the P6000 settings with the optimal Kollmorgen stepper motor requirements to provide the best performance and most efficient solution for nearly any application.

Features

- No programming required!
- Covers full power range of Kollmorgen Stepper Motors
- Switch Selectable Current Output from 0.2-5.7 Arms, 8.0 A peak
- 120/240 VAC Input (160/320 Vdc Bus)
- Kollmorgen Stepper Motor Pairing; Switch Selectable
- All Inputs and Outputs are Optically Isolated
- Single-Ended and Differential Step and Direction or CW/CCW Command; Switch Selectable
- Enable Input
- Fault Output (Sinking or Sourcing)
- Status LEDs for easy troubleshooting
- Switch Selectable Micro-Stepping-Resolution Settings
- Step Smoothing Filter; Switch Selectable
- Idle Current Reduction; Switch Selectable
- Anti-Resonance Based On Load Inertia; Switch Selectable
- Self-Test Conducts Spin Test to Confirm Proper Connection; Switch Selectable
- RoHS & CE Certified



P6000 Stepper Drive

P6000 Drive Controller Outline Drawings with Dimensions

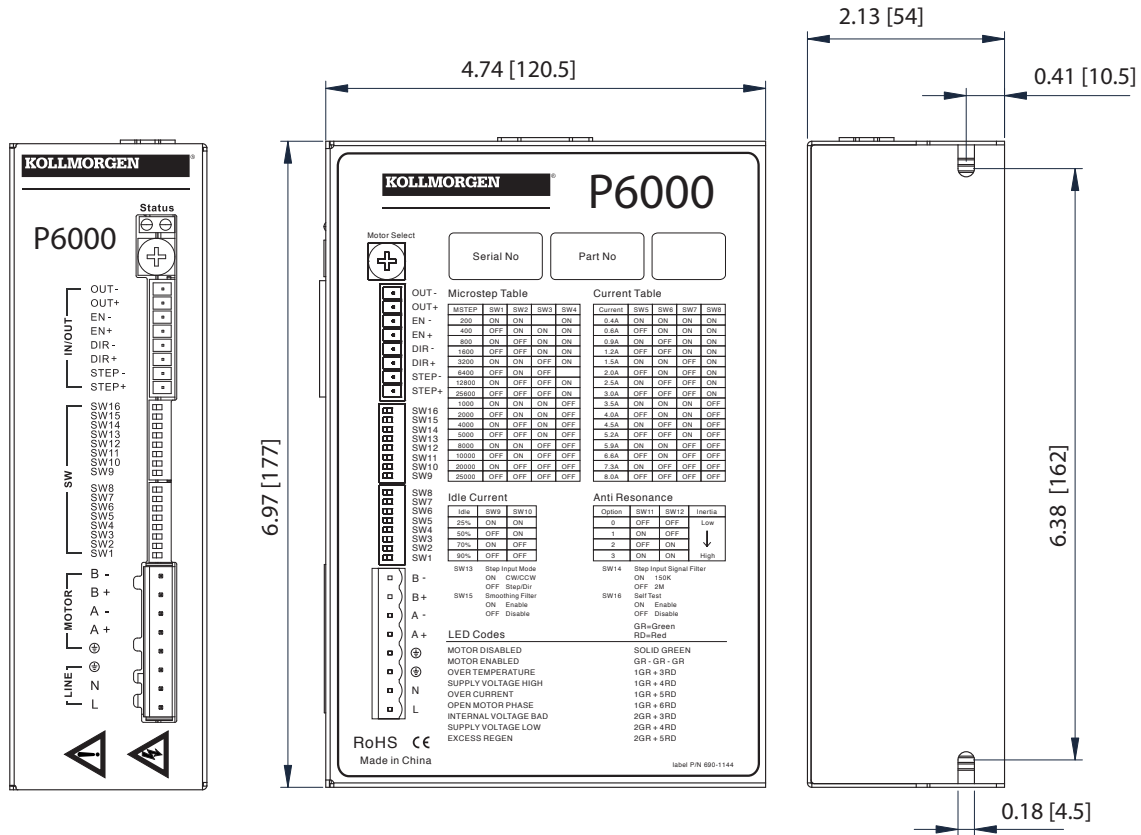

Dimensions in inches [mm]

P7000 Stepper Drive-Controller



P7000 stepper drives offer a unique level of system functionality, smoothness, high-speed performance and innovation unmatched in the industry.

The compact P7000 is designed to power Kollmorgen step motors ranging from NEMA size 17 up to NEMA size 42. Two power configurations are available for operation directly from AC power, or from a DC power supply.

There are two levels of control offered. The basic drive accepts step and direction inputs. P7000 drives are also available with an integrated position controller (-PN option). The drives are configured by either on-board dip switches, or with the P7000 tools software.

Advanced P7000 Features Make it the Best Choice to Meet Your Application Requirements

Multistep™

Also known as auto-smoothing. The P7000 drive accepts full step pulse commands from the indexer and inserts fine micro-steps to smooth coarse low speed motion. This allows you to significantly upgrade machine performance without having to redesign machine control architecture.

Auto-Tuning

Advanced current auto-tuning techniques provide outstanding low-speed smoothness. The P7000 senses the motor's characteristics and automatically fine tunes itself to meet your high-performance needs. This reduces installation and set-up time.

Mid-Band Anti-Resonance Control

Reduces negative effects of mechanical resonance, allowing you to get more out of a smaller motor and virtually eliminating nuisance stalls and machine downtime.

Idle Current Reduction

If you do not require the motor's full torque to hold a load at rest, you can select the right amount of current (torque) to reduce motor heating and power consumption. This increases the life of the system.

Dynamic Smoothing

Quasi-S-curve algorithm reduces jerk, especially upon acceleration. Increases mechanical life of the machine and reduces energy consumption.

Intelligent Indexing Option (-PN)

Wizard-like P7000 helps you to develop and link motion tasks such as homing and conditional and unconditional indexing. You can be up-and-running quickly.

Modbus RTU Compatible

The intelligent indexing option (-PN) supports Modbus RTU to control motion with an external interface device. External interfaces make controlling motion simple for machine operators.

P7000 Tools

The position node option allows you to configure up to 63 absolute or relative moves. You can specify the moves' distance, acceleration, velocity, and deceleration rates, or simply specify the distance and total time for the move – P7000 will perform the calculations automatically.

Specifications	Units	P70530	P70360
Input voltage range	Volts	20 - 75 Vdc	120 or 240 Vac
Continuous current	Amps rms	5	2.5
Microstep peak current	Amps peak	7.1	3.5

Note: For complete P7000 Series model nomenclature, refer to page 132.



P70360 AC Packaged Drive Controller Outline Drawings

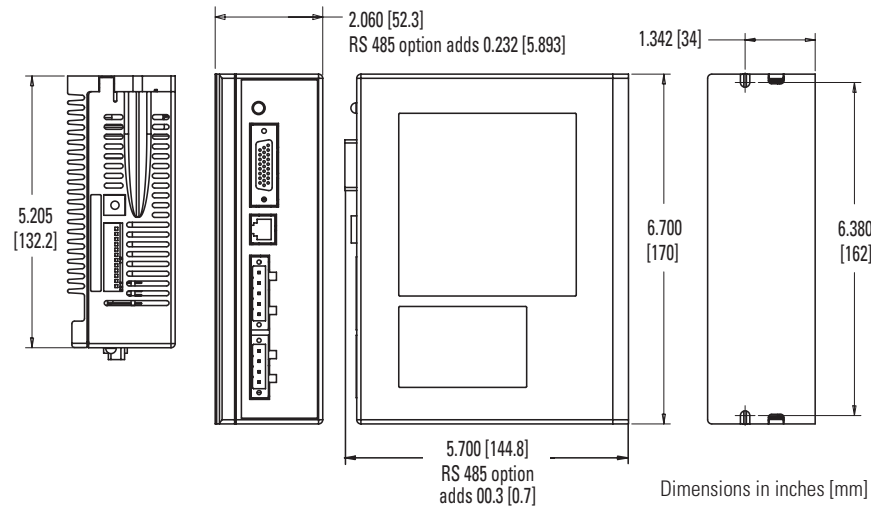

P70530 DC Modular Drive Controller Outline Drawings

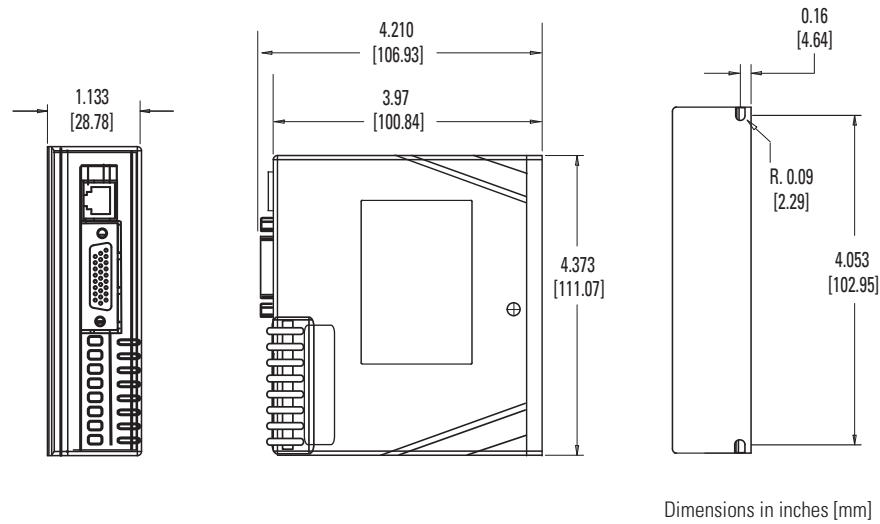

P7000 Drive Wiring Diagrams

P 7 0 0 0 D R I V E - C O N T R O L L E R W I R I N G D I A G R A M S

P70360 AC Packaged Drive Wiring Diagram

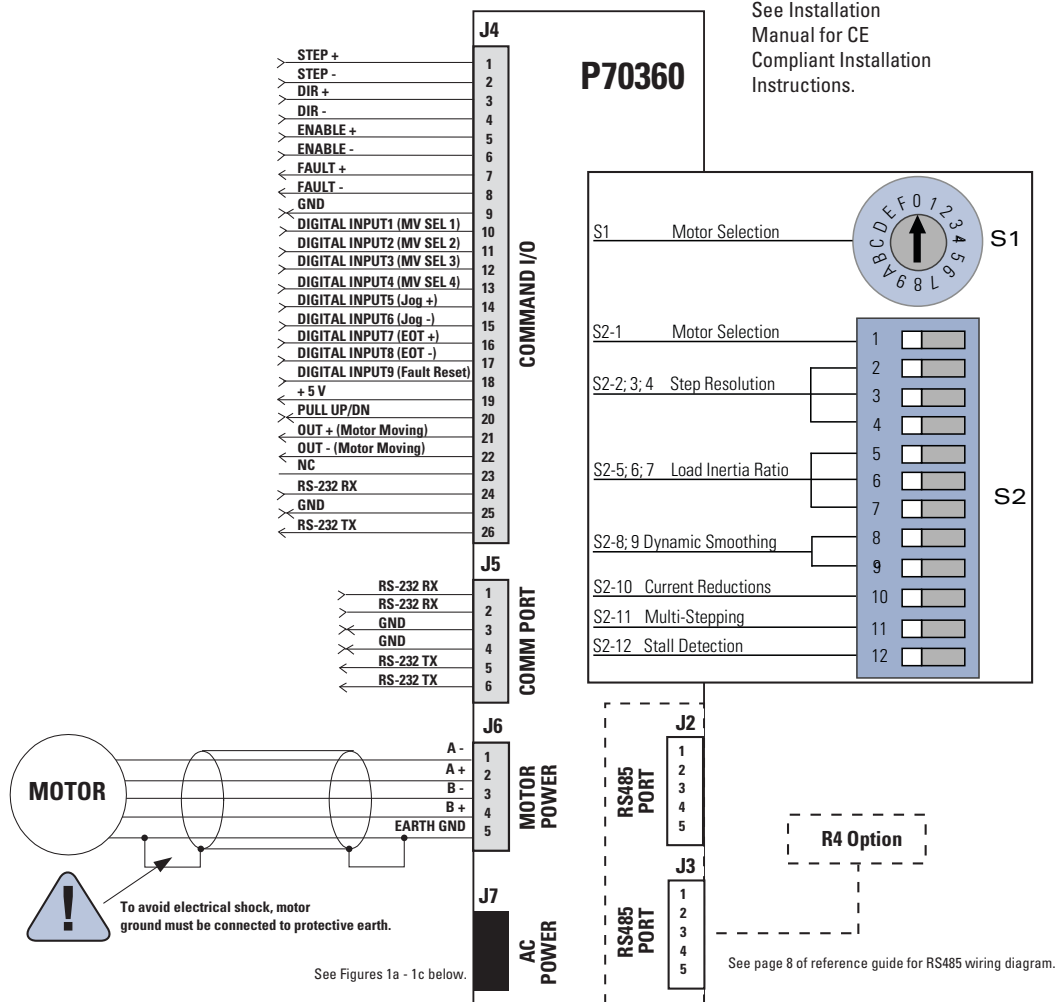

Figure 1a: Connection for a 320 VDC bus using 240 VAC.

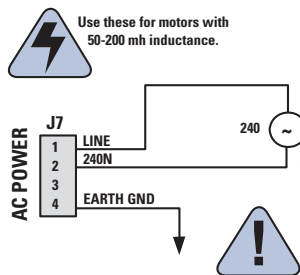

Figure 1b: Connection for a 320 VDC bus using 120 VAC.

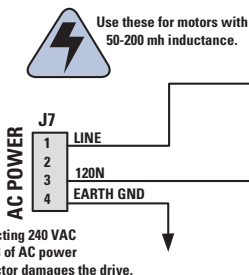
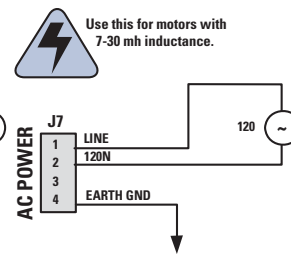
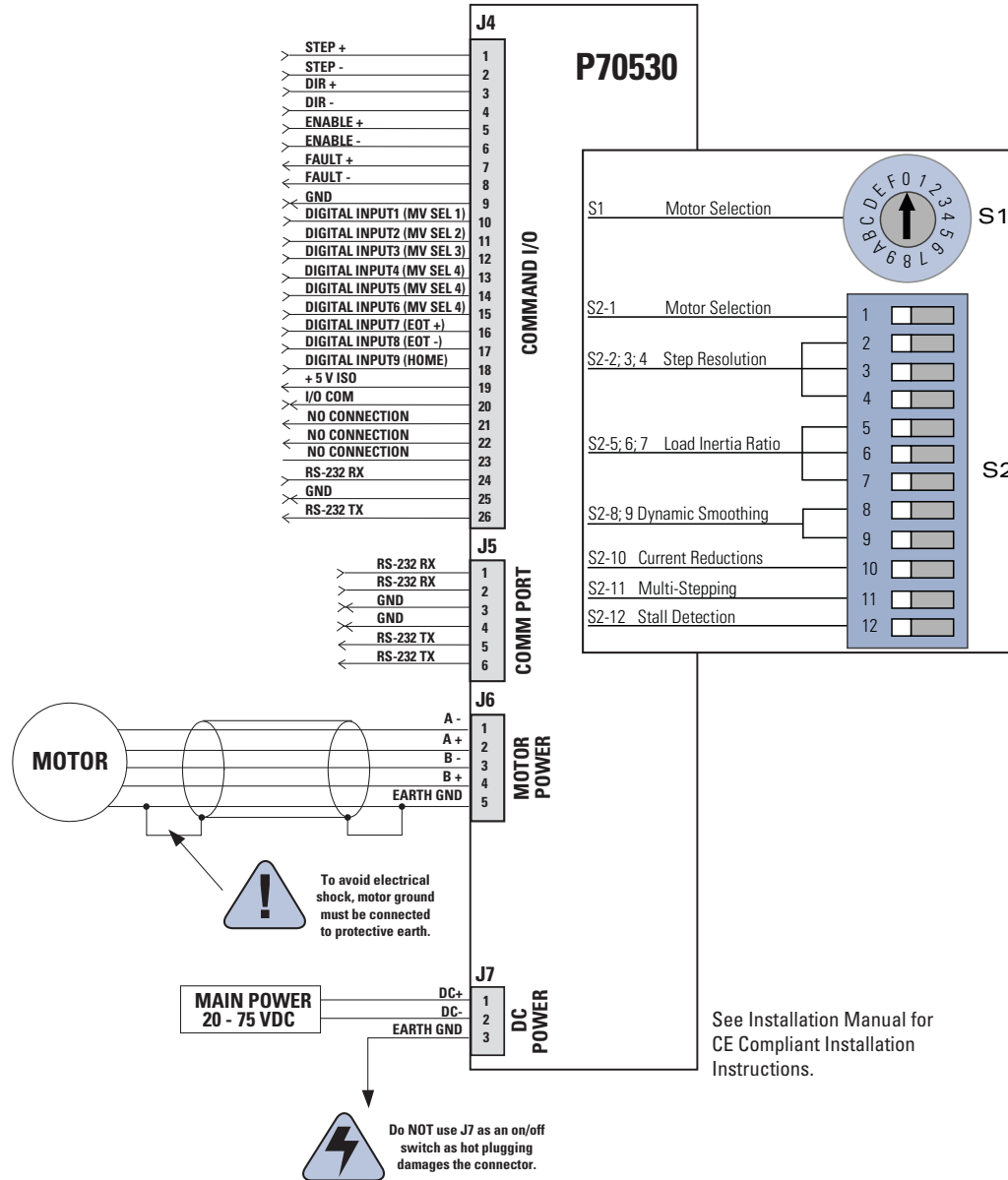

Figure 1c: Connection for a 160 VDC bus.



P70530 DC Modular Drive Wiring Diagram



Performance Summary

opper motor products including continuous torque, high torque and
 on requirements. For products not included in this catalog go to
 er Kollmorgen stepper motor products.

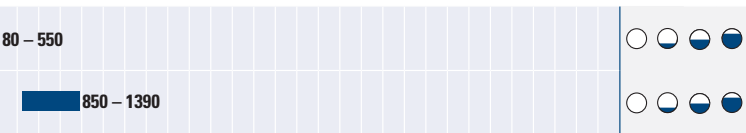
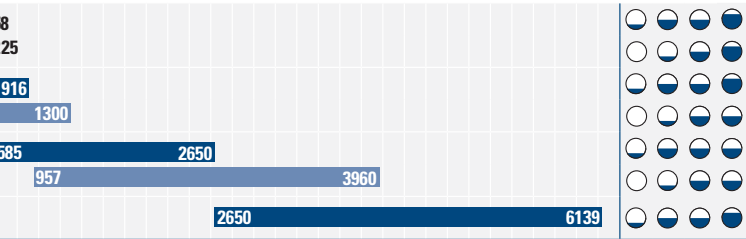
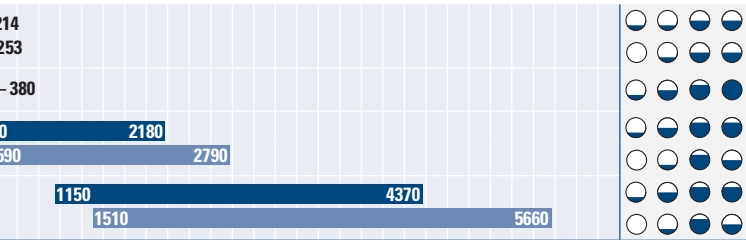
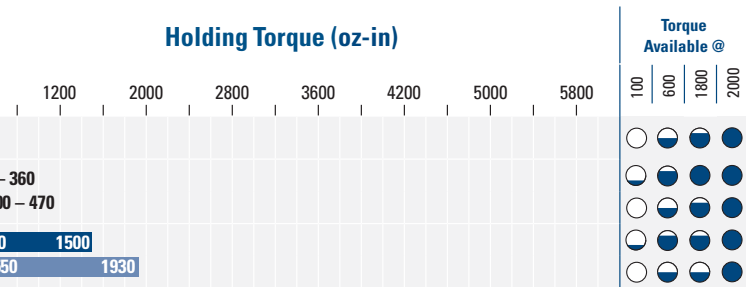

Standard Stepper Motor Construction
 Step motor utilizing SIGMAX® Technology

Better ← → Worse

○ ● ○ ● ○ ● ○ ● ○ ●

Product Family	Page Number	Features				Standard Options								
		NEMA	UL Recognized	CE Mark	SIGMAX® Technology	Integral Connectoin	Leaded	Terminal Box	MS Connector	IP 65 Sealing	Encoders	Rear Shaft		Low Inertia
CTP1	20	17	•	•			•					•		<ul style="list-style-type: none"> • High torque st • Enhanced CTM torque in sam • Large bearing • High Volume, • Minimum Qua
CTP2 CTM2	20	23	•	•	•		•					•		
CTP3 CTM3	20	34	•	•	•		•					•		

P2 M2	42	23	•	•	•	•	•					•	•	<ul style="list-style-type: none"> • High torque st • Enhanced M a torque in sam • Low detent to • Bipolar and un • Large array of
T2	38	23	•	•			•	•	•			•	•	
K3 N3	50	34	•	•	•		•	•	•	• ¹	•	•	•	
K4 N4	60	42	•	•	•		•	•	•	• ²	•	•	•	

H2 E2	66	23	•	•	•		•		•			•	•	<ul style="list-style-type: none"> • High efficienc round frame • Enhanced E S in the same p • Torque produc • Large array of • E2, H2 offer h
H3 E3	66	34	•	•	•		•		•	• ¹	•	•	•	
H4 E4	66	42	•	•	•		•		•	• ²	•	•	•	
MH172	82	66						•				•	•	

MX9	84	34	•										•	<ul style="list-style-type: none"> • Standard hyb • Meets Explos requirements • Up to 150% r and 200% for
MX11	86	42	•										•	

Notes: 1. Requires shaft seal and connection option other than leaded
 2. Requires shaft seal option

CTP/CTM Series Stepper Motor Overview

Kollmorgen has combined high performance stepper motor designs with world wide manufacturing capabilities to create the new CT Series Stepper Motors.

All CT Series Stepper Motors incorporate innovative cooling technology (patent pending), high torque magnetic designs, rugged bearings, and high voltage insulation systems. These features provide high torque motors, which support large mechanical loads, and can be used with all drives. In addition, CTM Maximum Series Stepper Motors use patented enhancing technology to increase efficiency and provide even more torque at all speeds.

Outstanding performance is only part of the CT story. CT Series motors are available in the most popular sizes (17, 23, and 34), and are available in a variety of lengths, windings and shafts.

Custom Motors

Kollmorgen routinely provides motors with many types of modifications. Please contact us with your specific requirements.

Shaft Modifications

A variety of motor output shaft modifications can be supplied. These include special flats and keyways, lengths, diameters, through holes and similar changes which may be needed to allow mounting of leadscrews, timing belts, pulleys or gears.

Electrical Modifications

Motors can be supplied with a number of electrical modifications, including: nonstandard lead lengths, electrical connectors and special windings.



CT Series Stepper Motors . . . run cooler, produce more torque, and support higher shaft loads than any other stepper motor.

CTM Series motors incorporate patented enhancing magnets in the stator to provide 25% more torque at all speeds. The increased power output comes from higher efficiency. This allows the use of smaller drives and power supplies. Available in size 23 and size 34 motors.

All CT motors utilize high torque magnetic designs that feature a large rotor diameter, small air gap, high energy rotor magnets and computer controlled windings. This provides maximum torque in the smallest package.

- Lower Energy Usage
- Faster Machines
- Lower System Cost
- More Compact Machines

High Voltage Insulation

Inset molded insulation system encases the stator, eliminating joints and gaps that can fail. Reliability and voltage ratings are increased. CT Series motors can be used with all standard drives, as well as high voltage high performance drives.

- Faster design cycles knowing CT Series motors work with all drives.
- Higher reliability

Cooling Shell (patent pending)

Aluminum shell and aluminum end-caps quickly remove heat from the motor. This allows for higher current and torque ratings, especially when the motor is mounted. CT motors produce the same torque at lower temperatures for longer life.

- Faster, higher throughput machines
- Reduced size
- Longer life

Large Bearing System

To accommodate high thrust loads and high side loading, CT Series motors feature large bearings.

Size 23 & 34 motors have the front bearing retained with a snap ring. And, the rear bearing is mounted in an O-ring to prevent spinout and minimize motor noise.

- Lower machine costs. Loads can be directly mounted on motor shaft eliminating couplings and load support bearings.
- Excellent for leadscrew applications
- Longer life

CTP/CTM Series Stepper Motors

General Specifications

- NEMA Sizes 17, 23, 34
- CTM Enhanced Series - Maximum Torque and Efficiency (not available in size 17)
- Excellent for use with leadscrews
- RoHS Compliant
- Unipolar or Bipolar windings
- Features: leadwire connection, NEMA through holes
- Options: Rear shaft & encoder mounting holes
- Custom Motors

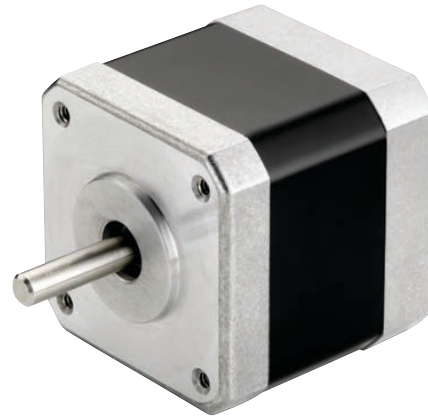

Parameter	CTP1	CTM2/ CTP2	CTM3/ CTP3
NEMA frame size	17	23	34
Phases	2 and 4		
Full Steps per Revolution	200		
Step Angle (degrees)	1.8		
Step Accuracy % (of one full step, no load)	+/- 5	+/- 3	+/- 3
Operating Temperature	-20° C to +140° C		
Insulation Class	Class B, 130° C		
Insulation Voltage (Vdc)	80	340	
Insulation Resistance	100 Megohms		

CTP1 Outline Drawings

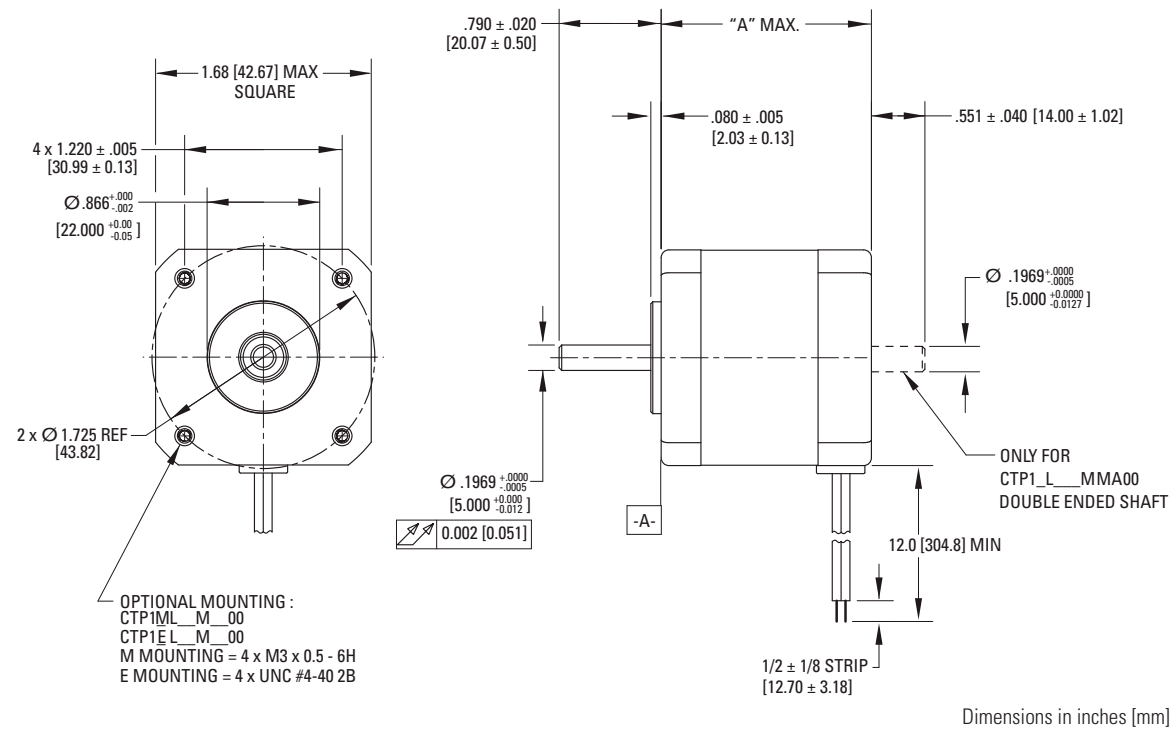

Model	"A" MAX
CTP10	1.350 ± 0.015 (34.3 ± 0.38)
CTP11	1.590 ± 0.015 (40.4 ± 0.38)
CTP12	1.900 ± 0.015 (48.3 ± 0.38)

Dimensions in inches [mm]

CTP/CTM Series Stepper Motors

CTP / CTM SERIES STEPPER MOTORS

CTP2 / CTM2 Outline Drawings

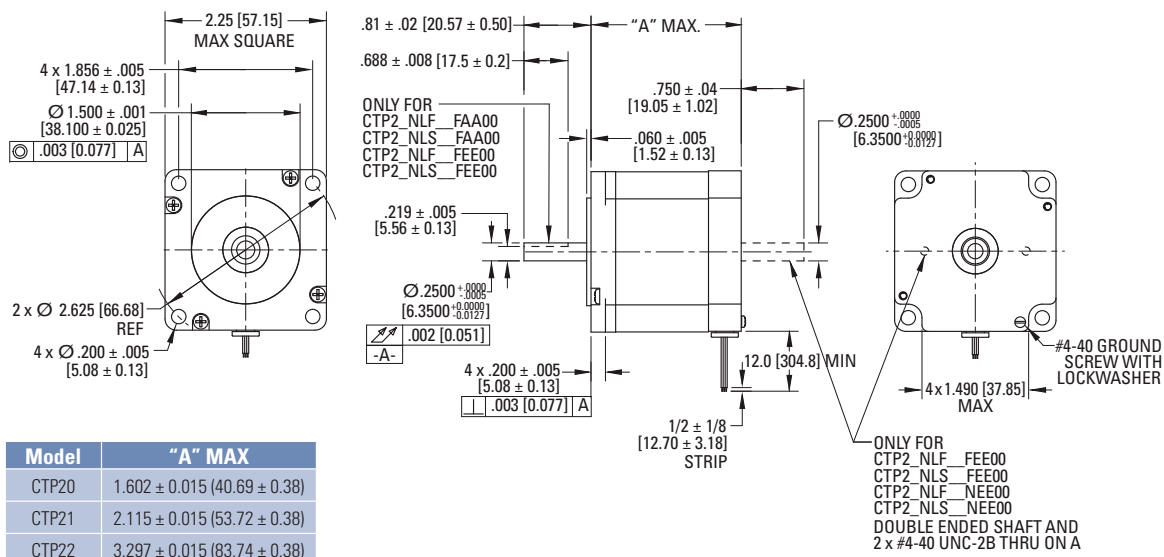

Dimensions in inches [mm]

CTP3 / CTM3 Outline Drawings

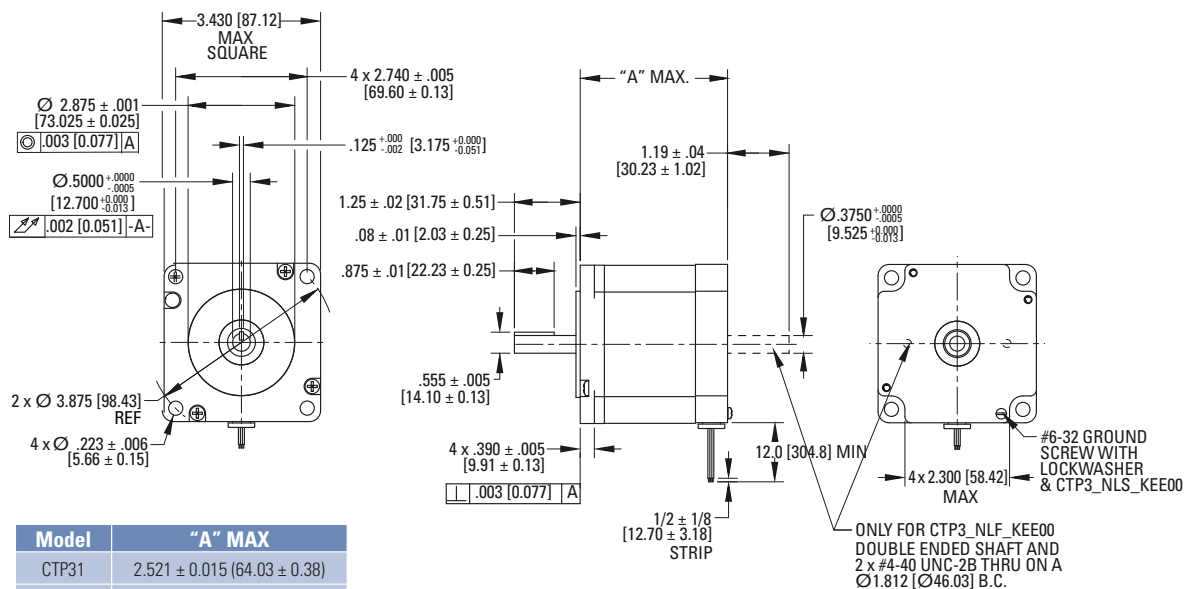

Dimensions in inches [mm]

CTP1 Performance Data

Motor Model Number	Config.		Holding Torque (2 phases on)	Rated Current/ Phase	Phase Resistance	Phase Inductance	Detent Torque	Thermal Resistance	Rotor Inertia	Weight	Shaft Loading*							
	Series	Unipolar									oz-in (Nm) +/-10%	Amps DC	Ohms +/-10%	mH Typical	oz-in (Nm)	Mounted °C/Watt	oz-in-s ² (kg-m ² x10 ⁻³)	lb (kg)
			lb (N)	lb (N)														
Short Stack	CTP10xxF16	•	43 (0.30)	1.6	2.15	3.0	2.0 (0.014)	6.21	0.00051 (0.0036)	0.45 (0.20)	15 (67)	Push 6.0 (27)						
	CTP10xxF10	•		1.0	5.25	7.7												
	CTP10xxF06	•		0.63	12.8	18												
	CTP10xxF04	•		0.40	30.5	42												
	CTP10xxS12	•	33 (0.23)	1.2	3.38	2.4							2.5 (0.018)	5.44	0.00075 (0.0053)	0.57 (0.26)	15 (67)	Pull 15 (67)
	CTP10xxS08	•		0.80	8.04	5.5												
	CTP10xxS05	•		0.50	19.4	13												
	CTP10xxS03	•		0.33	47.1	31												
1 Stack	CTP11xxF17	•	62 (0.44)	1.7	2.12	4.2	3.0 (0.021)	4.71	0.00106 (0.075)	0.76 (0.34)	15 (67)	Push 6.0 (27)						
	CTP11xxF11	•		1.1	5.19	11												
	CTP11xxF07	•		0.68	12.5	26												
	CTP11xxF04	•		0.44	30.4	60												
	CTP11xxS13	•	49 (0.35)	1.3	3.31	3.4							3.0 (0.021)	4.71	0.00106 (0.075)	0.76 (0.34)	15 (67)	Pull 15 (67)
	CTP11xxS09	•		0.85	8.02	8.0												
	CTP11xxS06	•		0.55	18.9	18												
	CTP11xxS03	•		0.35	48.1	47												
2 Stack	CTP12xxF26	•	80 (0.56)	2.6	1.09	1.9	3.0 (0.021)	4.71	0.00106 (0.075)	0.76 (0.34)	15 (67)	Push 6.0 (27)						
	CTP12xxF16	•		1.6	2.65	4.9												
	CTP12xxF10	•		1.0	6.51	12												
	CTP12xxF07	•		0.65	15.7	30												
	CTP12xxS20	•	62 (0.44)	2.0	1.70	1.6							3.0 (0.021)	4.71	0.00106 (0.075)	0.76 (0.34)	15 (67)	Pull 15 (67)
	CTP12xxS13	•		1.3	4.13	3.9												
	CTP12xxS08	•		0.82	10.1	9.2												
	CTP12xxS05	•		0.53	23.8	21												

*Notes: *Maximum shaft loading based on 20,000 hours of operation at 1500 rpm.

See page 88 for CT series connector diagrams and switching sequences.

CTP/CTM Series Stepper Motors

CTP / CTM SERIES STEPPER MOTORS

CTP1 Performance Curves

CTP10xxF10 w/ P70530

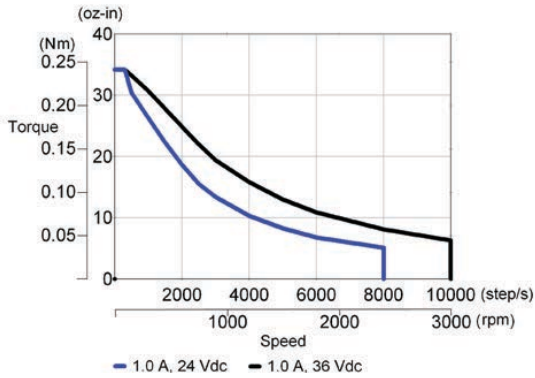

CTP10xxF16 w/ P70530

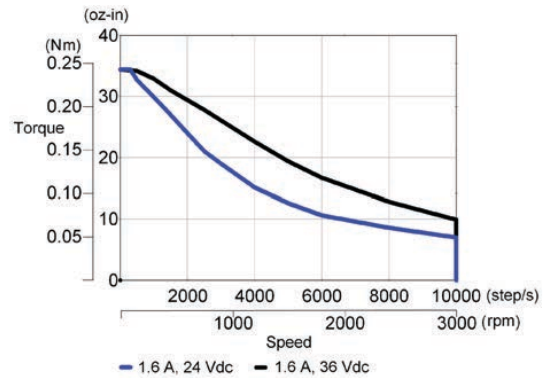

CTP11xxF11 w/ P70530

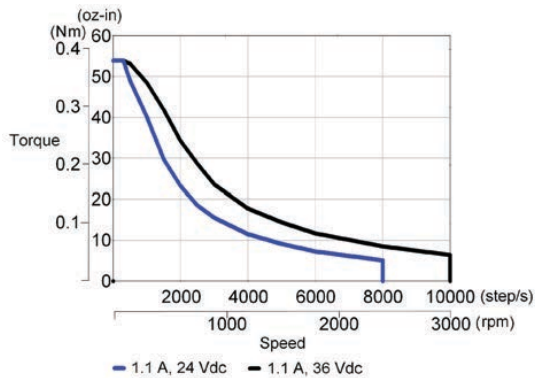

CTP11xxF17 w/ P70530

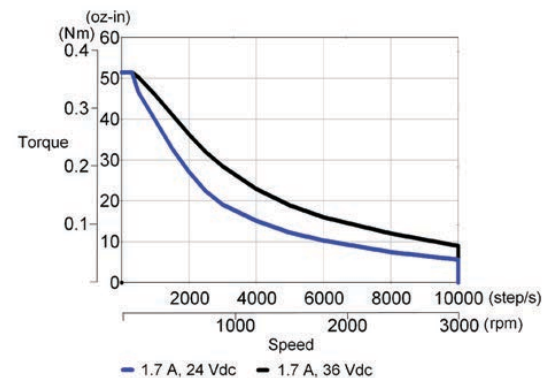

CTP12xxF10 w/ P70530

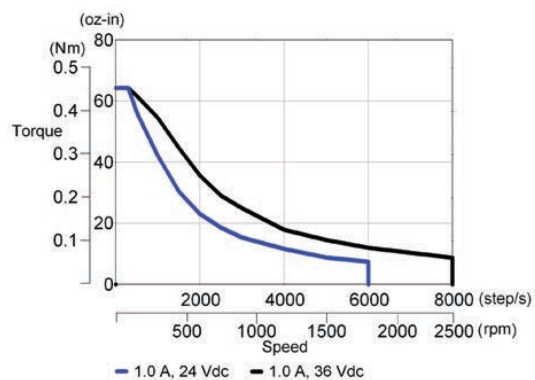

CTP12xxF26 w/ P70530

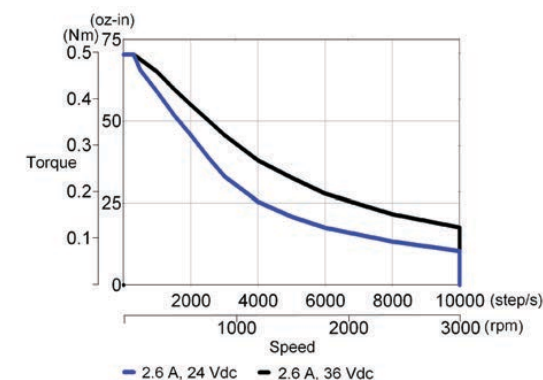

CTP2 / CTM2 Performance Data

Motor Model Number	Config.		Holding Torque (2 phases on)	Rated Current/Phase	Phase Resistance	Phase Inductance	Detent Torque	Thermal Resistance	Rotor Inertia	Weight	Shaft Loading*	
	Series	Unipolar									oz-in (Nm) +/- 10%	Amps DC
			lb (N)	lb (N)								
Short Stack	CTP20xxF38	•	100 (0.71)	3.8	0.58	1.3	5.0 (0.035)	3.99	0.0026 (0.018)	1.0 (0.45)	20 (89)	50 (222)
	CTP20xxF27	•		2.7	1.11	2.5						
	CTP20xxF17	•		1.7	2.87	7.1						
	CTP20xxF11	•		1.1	6.98	17						
	CTP20xxF07	•		0.68	17.1	41						
	CTP20xxF04	•		0.45	40.6	89						
	CTP20xxS34	•	75 (0.53)	3.4	0.73	0.83						
	CTP20xxS21	•		2.1	1.83	2.2						
	CTP20xxS13	•		1.3	4.39	5.2						
CTP20xxS09	•		0.87	10.5	12							
1 Stack	CTP21xxF56	•	200 (1.41)	5.6	0.31	1.1	8.0 (0.056)	3.57	0.0035 (0.025)	1.4 (0.64)	20 (89)	50 (222)
	CTP21xxF39	•		3.9	0.60	2.2						
	CTP21xxF25	•		2.5	1.48	5.8						
	CTP21xxF15	•		1.5	3.86	16						
	CTP21xxF10	•		1.0	9.40	38						
	CTP21xxF04	•		0.45	44.0	170						
	CTP21xxS48	•	160 (1.13)	4.8	0.41	0.74						
	CTP21xxS31	•		3.1	0.97	1.9						
	CTP21xxS19	•		1.9	2.44	5.0						
	CTP21xxS12	•		1.2	5.89	12						
Enhanced 1 Stack	CTM21xxF56	•	260 (1.84)	5.6	0.31	0.78	13 (0.092)	3.57	0.0035 (0.025)	1.5 (0.68)	20 (89)	50 (222)
	CTM21xxF39	•		3.9	0.60	1.6						
	CTM21xxF25	•		2.5	1.48	4.2						
	CTM21xxF15	•		1.5	3.86	12						
	CTM21xxF10	•		1.0	9.40	28						
	CTM21xxF04	•		0.45	44.0	123						
	CTM21xxS48	•	200 (1.41)	4.8	0.41	0.54						
	CTM21xxS31	•		3.1	0.97	1.4						
	CTM21xxS19	•		1.9	2.44	3.7						
	CTM21xxS12	•		1.2	5.89	8.6						

Notes: *Maximum shaft loading based on 20,000 hours of operation at 1500 rpm.
See page 88 for CT series connector diagrams and switching sequences.

Continued on page 28.

CTP/CTM Series Stepper Motors

CTP / CTM SERIES STEPPER MOTORS

CTP2 / CTM2 Performance Data (continued)

Motor Model Number	Config.		Holding Torque (2 phases on) oz-in (Nm) +/-10%	Rated Current/ Phase Amps DC	Phase Resistance Ohms +/-10%	Phase Inductance mH Typical	Detent Torque oz-in (Nm)	Thermal Resistance Mounted °C/Watt	Rotor Inertia oz-in-s ² (kg-m ² x10 ⁻³)	Weight lb (kg)	Shaft Loading*	
	Series	Unipolar									Radial Force lb (N)	Axial Force lb (N)
	2 Stack	CTP22xxF69	•	360 (2.54)	6.9	0.28	1.2	12 (0.085)	2.62	0.0068 (0.048)	2.4 (1.09)	20 (89)
CTP22xxF50		•	5.0		0.52	2.2						
CTP22xxF31		•	3.1		1.31	6.1						
CTP22xxF19		•	1.9		3.25	16						
CTP22xxF12		•	1.2		8.40	41						
CTP22xxF06		•	0.60		32.2	150						
CTP22xxS49		•	285 (2.01)	4.9	0.53	1.2						
CTP22xxS31		•		3.1	1.30	3.0						
CTP22xxS19		•		1.9	3.39	8.3						
CTP22xxS12	•		1.2	8.26	20							
Enhanced 2 Stack	CTM22xxF69	•	470 (3.32)	6.9	0.28	0.81	22 (0.16)	2.62	0.0068 (0.048)	2.5 (1.13)	20 (89)	50 (222)
	CTM22xxF50	•		5.0	0.52	1.6						
	CTM22xxF31	•		3.1	1.31	4.3						
	CTM22xxF19	•		1.9	3.25	11						
	CTM22xxF12	•		1.2	8.40	29						
	CTM22xxF06	•		0.60	32.2	108						
	CTM22xxS49	•	360 (2.54)	4.9	0.53	0.81						
	CTM22xxS31	•		3.1	1.30	2.1						
	CTM22xxS19	•		1.9	3.39	5.9						
	CTM22xxS12	•		1.2	8.26	14						

Notes: *Maximum shaft loading based on 20,000 hours of operation at 1500 rpm.

See page 88 for CT series connector diagrams and switching sequences.

CTP2 / CTM2 Performance Curves

CTP20xxF17 w/ P70530

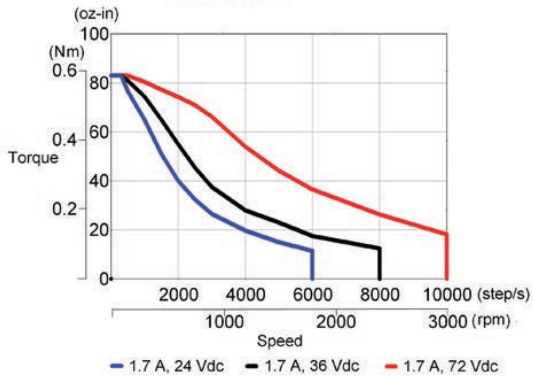

CTP20xxF27 w/ P70530

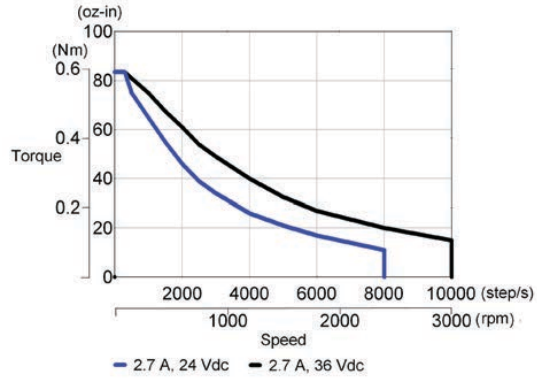

CTP21xxF25 w/ P70530

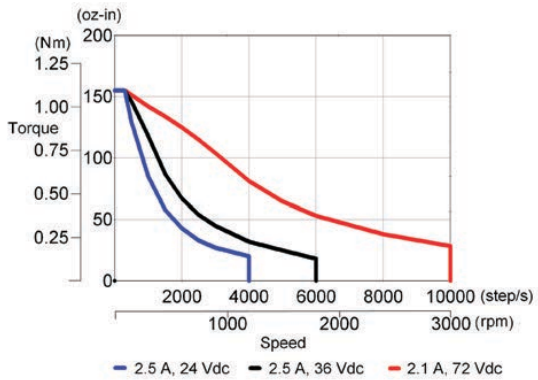

CTM21xxF25 w/ P70530

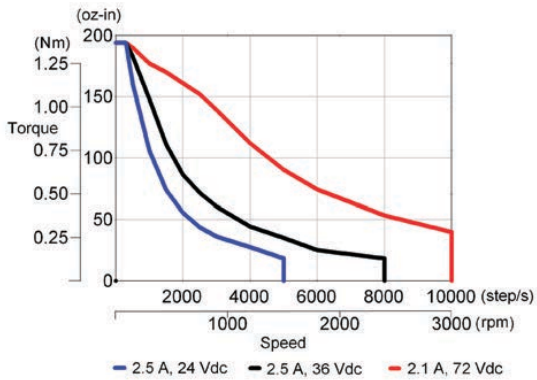

CTP21xxF39 w/ P70530

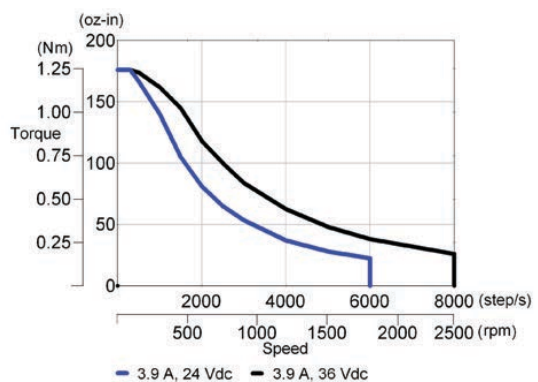

CTM21xxF39 w/ P70530

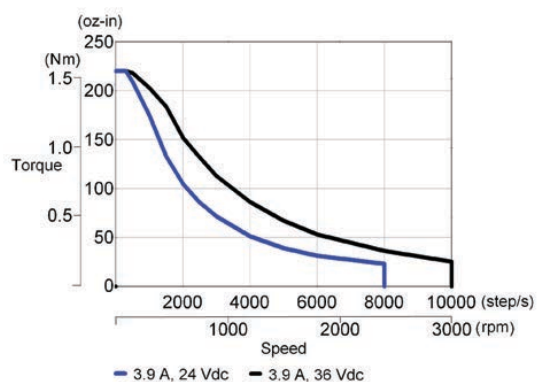

CTP/CTM Series Stepper Motors

CTP / CTM SERIES STEPPER MOTORS

CTP2 / CTM2 Performance Curves

CTP21xxF15 w/ P70530

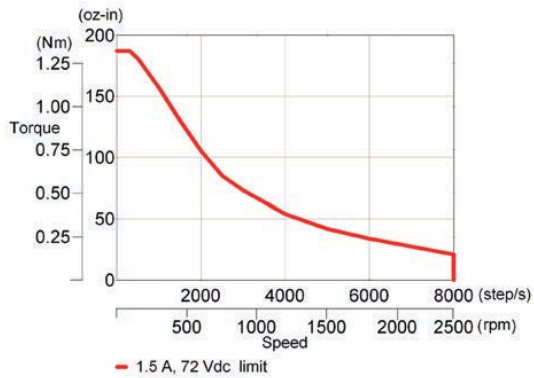

CTM21xxF15 w/ P70530

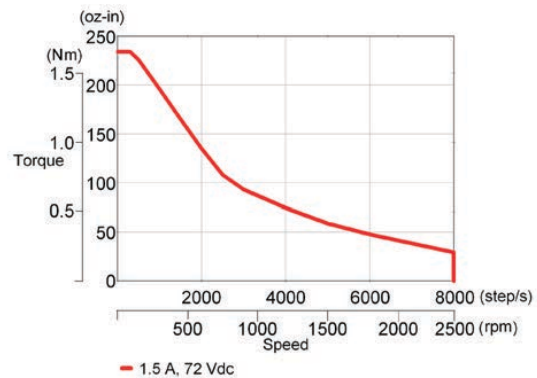

CTP22xxF50 w/ P70530

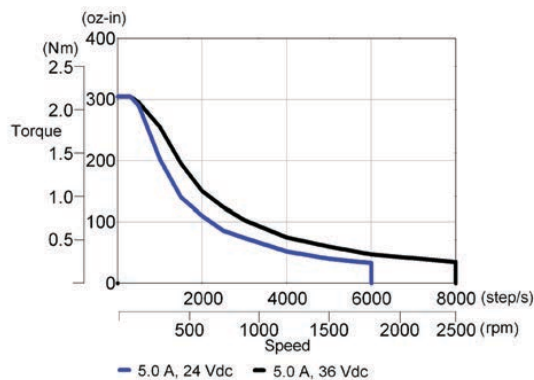

CTM22xxF50 w/ P70530

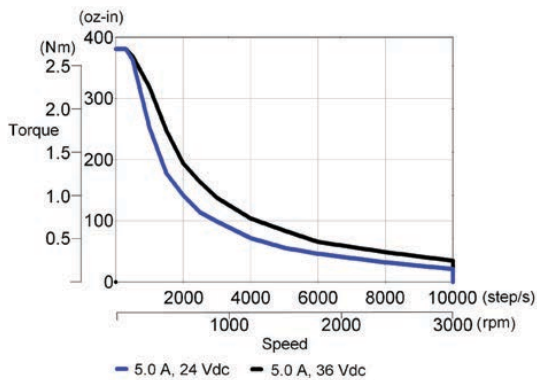

CTP22xxF31 w/ P70530

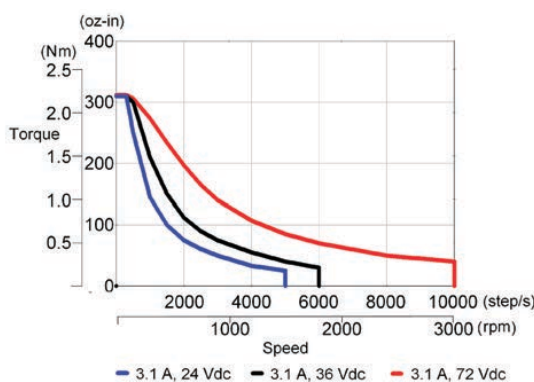

CTM22xxF31 w/ P70530

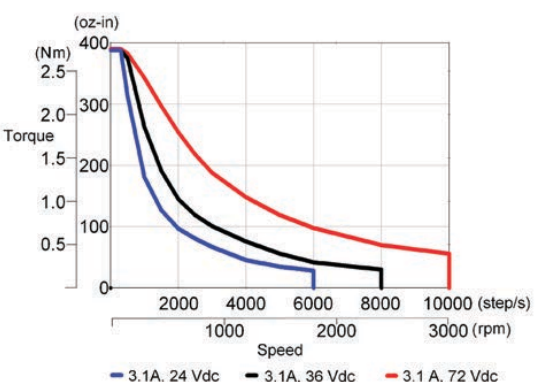

CTP2 / CTM2 Performance Curves

CTP21xxF04 w/ P70360

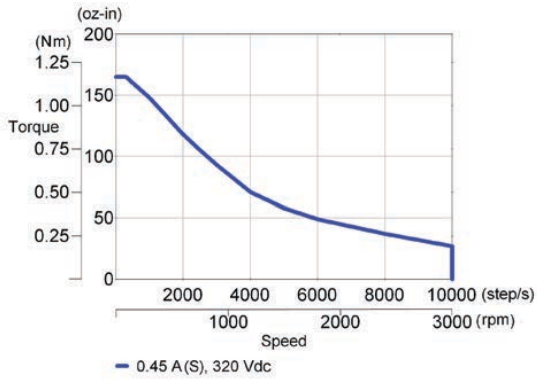

CTM21xxF04 w/ P70360

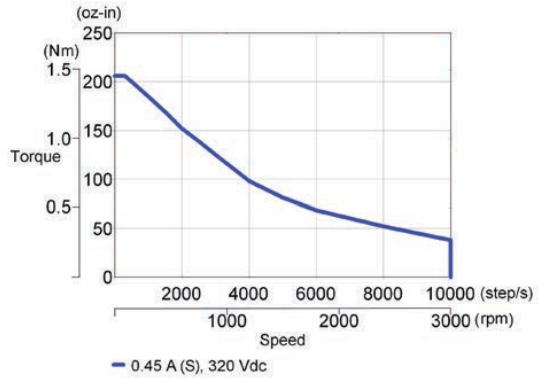

CTP22xxF06 w/ P70360

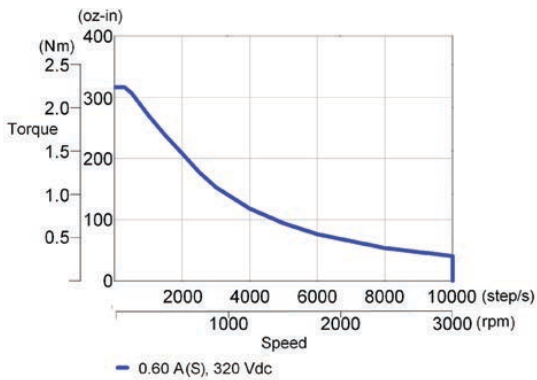

CTM22xxF06 w/ P70360

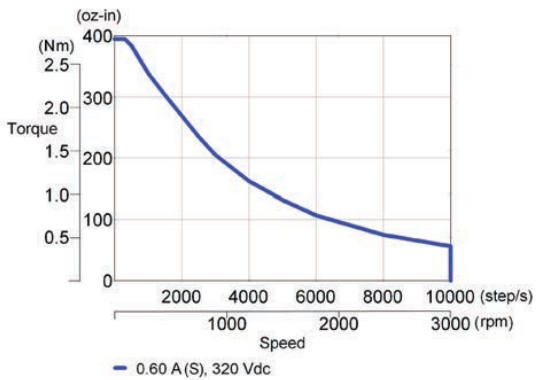

CTP/CTM Series Stepper Motors

CTP / CTM SERIES STEPPER MOTORS

CTP3 / CTM3 Performance Data

Motor Model Number	Config.		Holding Torque (2 phases on) oz-in (Nm) +/-10%	Rated Current/Phase Amps DC	Phase Resistance Ohms +/-10%	Phase Inductance mH Typical	Detent Torque oz-in (Nm)	Thermal Resistance Mounted °C/Watt	Rotor Inertia oz-in-s ² (kg-m ² x 10 ⁻³)	Weight lb (kg)	Shaft Loading*	
	Series	Unipolar									Radial Force lb (N)	Axial Force lb (N)
Short Stack	CTP31xxF99	•	565 (3.99)	9.9	0.19	1.2	22 (0.16)	2.02	0.0185 (0.131)	4.0 (1.8)	65 (289)	100 (445)
	CTP31xxF72	•		7.2	0.34	2.3						
	CTP31xxF45	•		4.5	0.79	5.8						
	CTP31xxF28	•		2.8	2.02	16						
	CTP31xxF09	•		0.90	19.5	150						
	CTP31xxS56	•	460 (3.25)	5.6	0.53	1.9						
	CTP31xxS35	•		3.5	1.29	4.9						
	CTP31xxS22	•		2.2	3.21	13						
Enhanced Short Stack	CTM31xxF99	•	690 (4.87)	9.9	0.19	0.87	30 (0.21)	2.02	0.0185 (0.131)	4.1 (1.9)	65 (289)	100 (445)
	CTM31xxF72	•		7.2	0.34	1.7						
	CTM31xxF45	•		4.5	0.79	4.3						
	CTM31xxF28	•		2.8	2.02	12						
	CTM31xxF09	•		0.90	19.5	112						
	CTM31xxS56	•	550 (3.88)	5.6	0.53	1.4						
	CTM31xxS35	•		3.5	1.29	3.7						
	CTM31xxS22	•		2.2	3.21	9.4						
1 Stack	CTP32xxF99	•	1100 (7.77)	9.9	0.23	1.8	30 (0.21)	1.55	0.0370 (0.261)	6.5 (3.0)	65 (289)	100 (445)
	CTP32xxF73	•		7.3	0.41	3.4						
	CTP32xxF46	•		4.6	1.01	9.1						
	CTP32xxF28	•		2.8	2.53	24						
	CTP32xxF11	•		1.1	16.1	150						
	CTP32xxS58	•	890 (628)	5.8	0.65	2.8						
	CTP32xxS36	•		3.6	1.63	7.6						
	CTP32xxS23	•		2.3	4.00	19						
Enhanced 1 Stack	CTM32xxF99	•	1350 (9.53)	9.9	0.23	1.4	41 (0.29)	1.55	0.0370 (0.261)	6.6 (3.0)	65 (289)	100 (445)
	CTM32xxF73	•		7.3	0.41	2.7						
	CTM32xxF46	•		4.6	1.01	7.1						
	CTM32xxF28	•		2.8	2.53	19						
	CTM32xxF11	•		1.1	16.1	120						
	CTM32xxS58	•	1070 (7.56)	5.8	0.65	2.2						
	CTM32xxS36	•		3.6	1.63	6.0						
	CTM32xxS23	•		2.3	4.00	15						

Notes: *Maximum shaft loading based on 20,000 hours of operation at 1500 rpm.
See page 88 for CT series connector diagrams and switching sequences.

Continued on page 33.

CTP3 / CTM3 Performance Data (continued)

Motor Model Number	Config.		Holding Torque (2 phases on)	Rated Current/ Phase	Phase Resistance	Phase Inductance	Detent Torque	Thermal Resistance	Rotor Inertia	Weight	Shaft Loading*	
	Series	Unipolar	oz-in (Nm) +/-10%	Amps DC	Ohms +/-10%	mH Typical	oz-in (Nm)	Mounted °C/Watt	oz-in-s ² (kg-m ² x10 ⁻³)	lb (kg)	Radial Force lb (N)	Axial Force lb (N)
2 Stack	CTP33xxF99	•	1570 (11.1)	9.9	0.24	2.0	38 (0.27)	1.36	0.0555 (0.392)	9.1 (4.1)	65 (289)	100 (445)
	CTP33xxF75	•		7.5	0.45	4.0						
	CTP33xxF47	•		4.7	1.08	10						
	CTP33xxF29	•		2.9	2.73	27						
	CTP33xxF13	•		1.3	13.8	140						
	CTP33xxS59	•	1250 (8.83)	5.9	0.70	3.2						
	CTP33xxS37	•		3.7	1.74	8.4						
CTP33xxS23	•	2.3		4.31	21							
Enhanced 2 Stack	CTM33xxF99	•	1930 (13.6)	9.9	0.24	1.6	52 (0.37)	1.36	0.0555 (0.392)	9.3 (4.2)	65 (289)	100 (445)
	CTM33xxF75	•		7.5	0.45	3.2						
	CTM33xxF47	•		4.7	1.08	8.2						
	CTM33xxF29	•		2.9	2.73	22						
	CTM33xxF13	•		1.3	13.8	111						
	CTM33xxS59	•	1500 (10.6)	5.9	0.70	2.6						
	CTM33xxS37	•		3.7	1.74	6.7						
CTM33xxS23	•	2.3		4.31	17							

Notes: *Maximum shaft loading based on 20,000 hours of operation at 1500 rpm.
See page 88 for CT series connector diagram of switching sequences.

CTP/CTM Series Stepper Motors

CTP / CTM SERIES STEPPER MOTORS

CTP3 / CTM3 Performance Curves

CTP3xxF72 w/ P70530

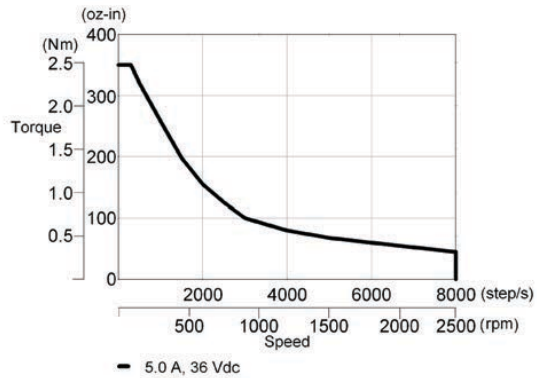

CTM31xxF72 w/ P70530

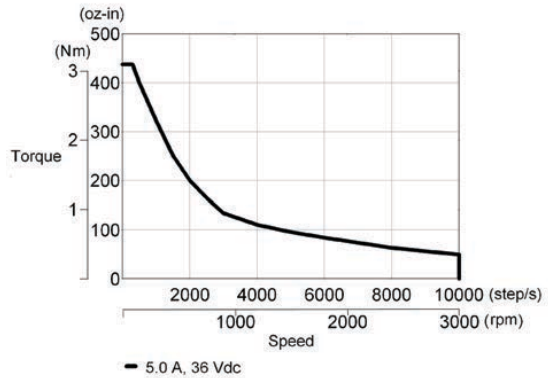

CTP31xxF28 w/ P70530

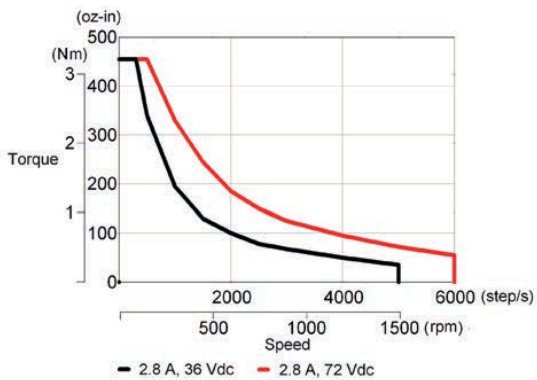

CTM31xxF28 w/ P70530

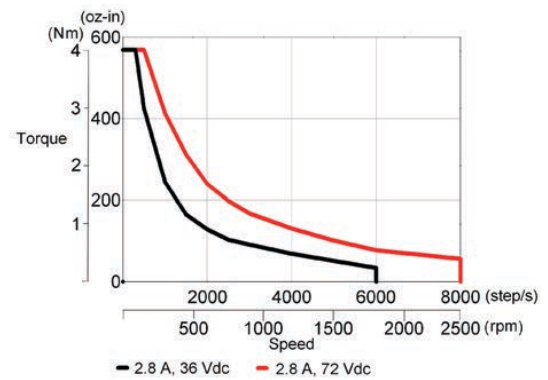

CTP31xxF45 w/ P70530

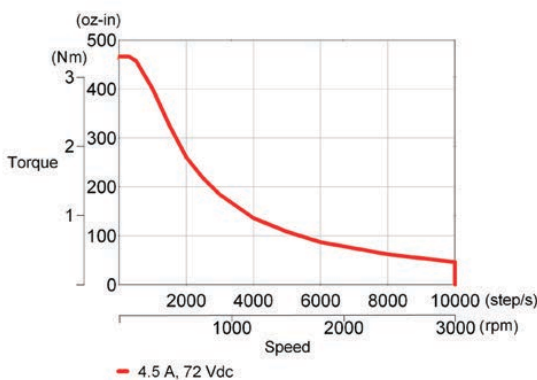

CTM31xxF45 w/ P70530

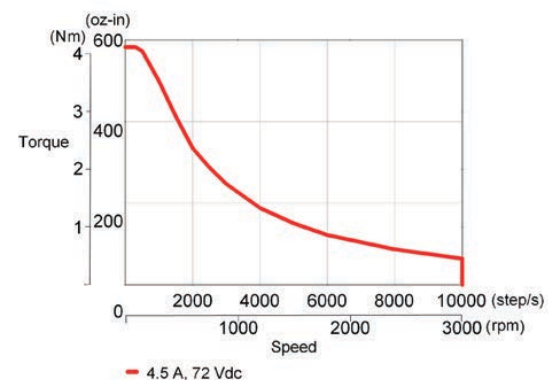

CTP3 / CTM3 Performance Curves

CTP32xxF73 w/ P70530

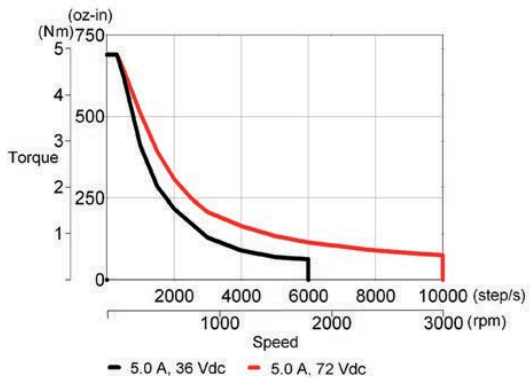

CTM32xxF73 w/ P70530

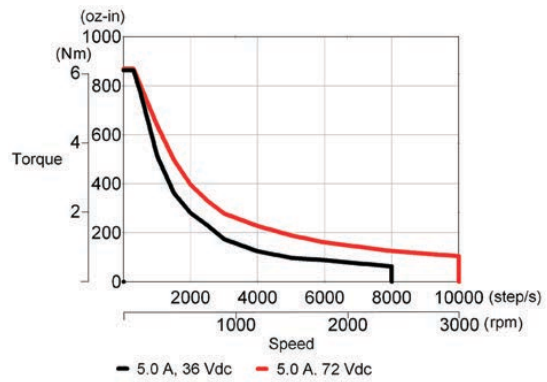

CTP32xxF46 w/ P70530

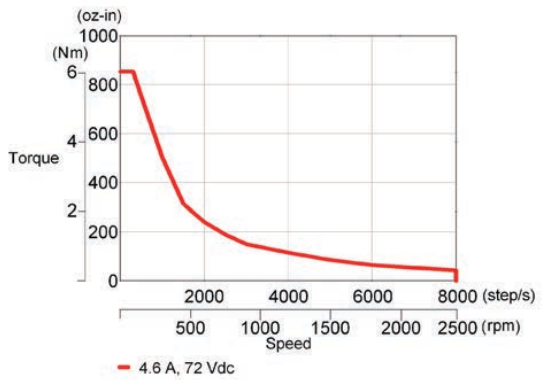

CTM32xxF46 w/ P70530

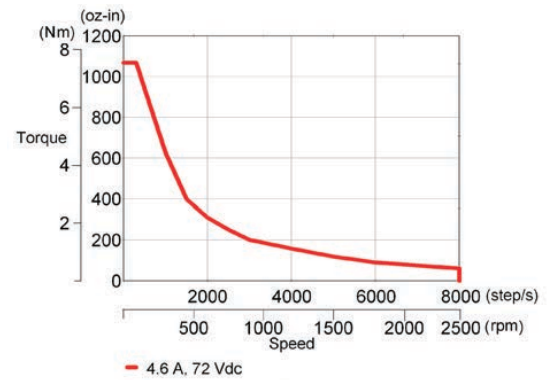

CTP/CTM Series Stepper Motors

CTP / CTM SERIES STEPPER MOTORS

CTP3 / CTM3 Performance Curves

CTP33xxF47 w/ P70530

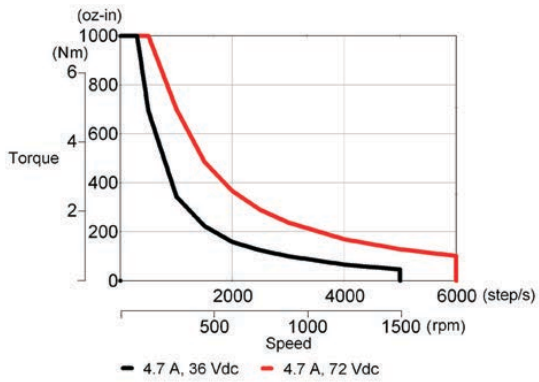

CTM33xxF47 w/ P70530

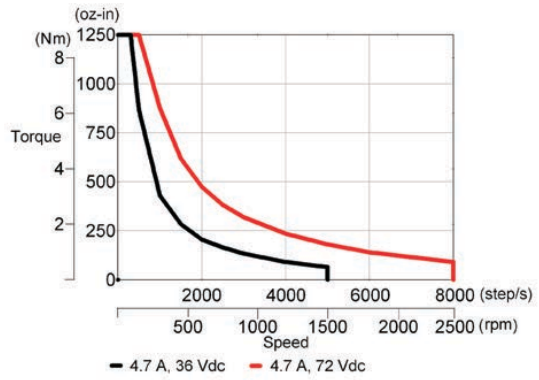

CTP33xxF75 w/ P70530

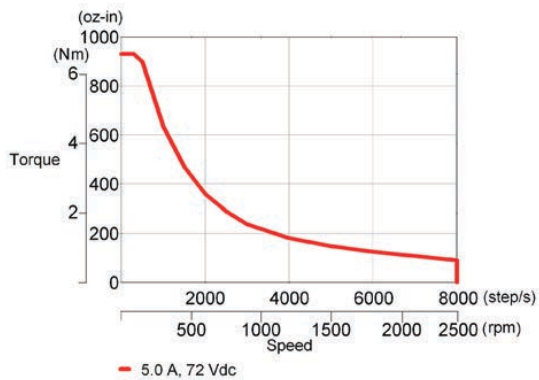

CTM33xxF75 w/ P70530

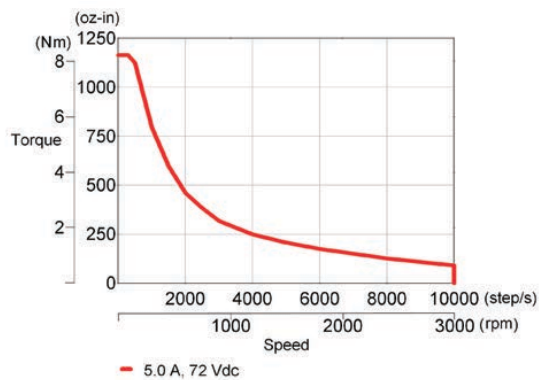

CTP3 / CTM3 Performance Curves

CTP31xxF09 w/ P70360

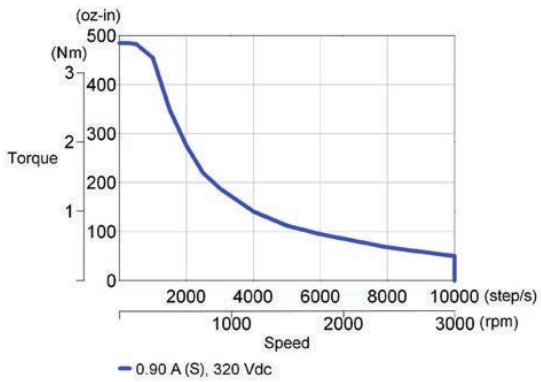

CTM31xxF09 w/ P70360

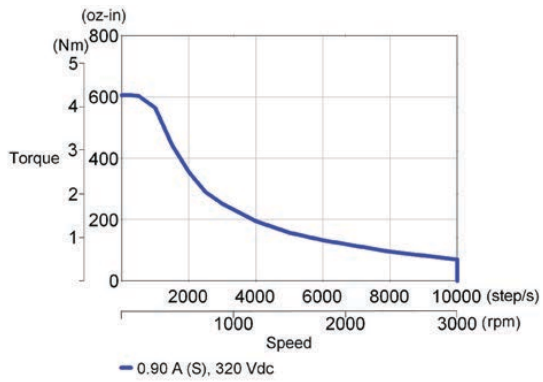

CTP32xxF11 w/ P70360

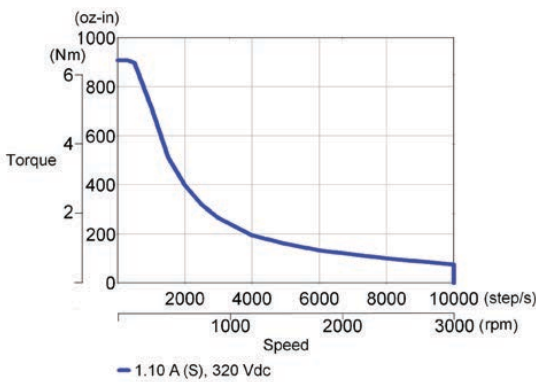

CTM32xxF11 w/ P70360

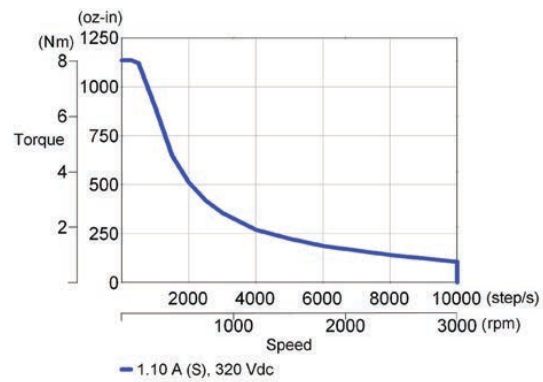

CTP33xxF13 w/ P70360

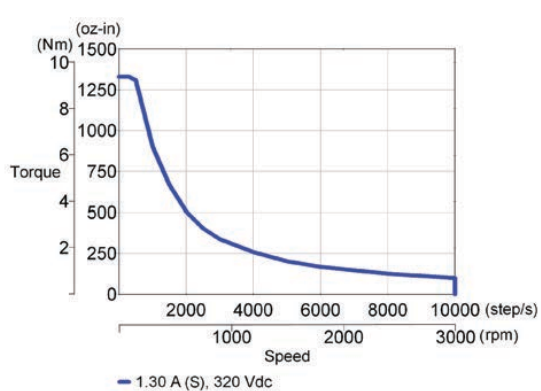

CTM33xxF13 w/ P70360

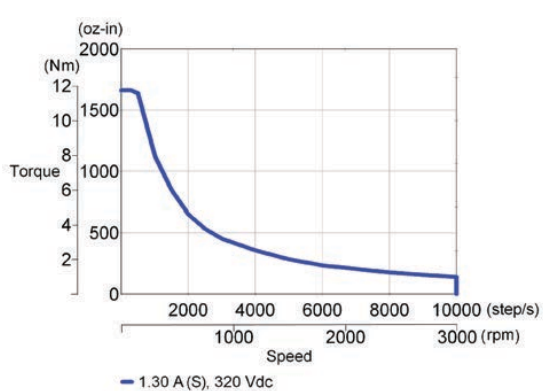

T2 Series Stepper Motors

General Specifications

- NEMA Size 23
- High Torque at moderate speeds
- Inch standard mounting
- CE cUR and UR compliant
- Unipolar or Bipolar windings
- Features: leadwire connection, flat or smooth shaft
- Options: MS connector, terminal boxes, encoder mounting provisions, 200 LPR, 400 LPR encoders with line drivers
- Custom Motors

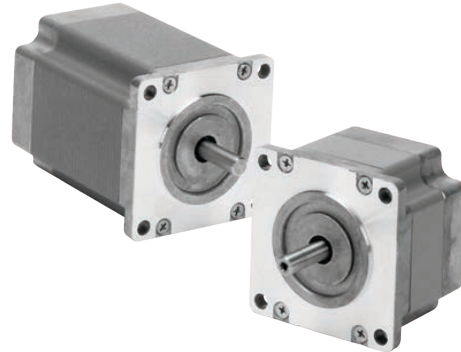

Phases	2
Full Steps per Revolution	200
Step Angle	1.8°
Step Accuracy (of one full step, no load)	± 2 %
Operating Temperature	-20°C to +40°C
Insulation Class	Class B, 130°C
Insulation Voltage Rating	340 Vdc
Insulation Resistance	100 Megohms

T2 Outline Drawings

Leadwire Hookup Models

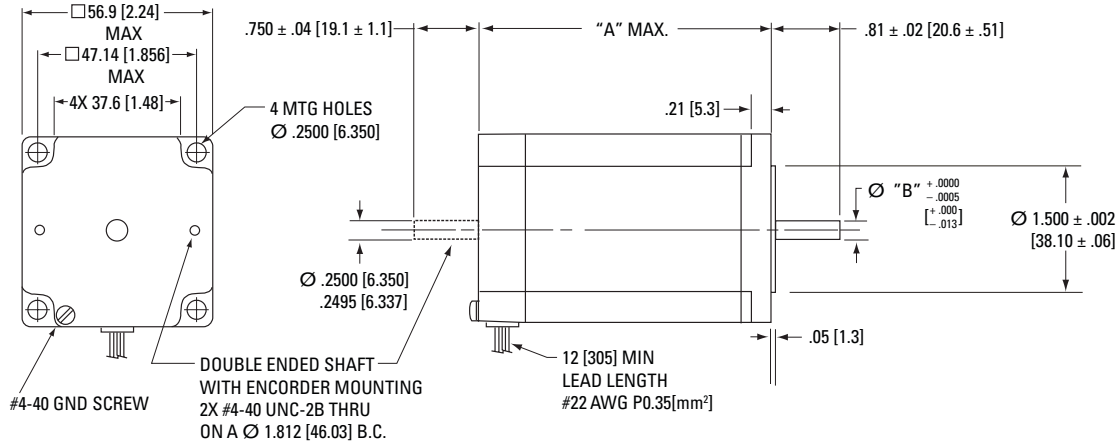

Dimensions in inches [mm]

Model	"A" Max	"B" Max
T2H	1.64 (41.6)	
T21	2.21 (56.1)	0.2500 (6.35)
T22	3.06 (77.7)	
T23	4.06 (103.1)	0.3125 (7.94)

Terminal Box Construction

Model	"A" Max
T2H	2.84 (72.1)
T21	3.41 (86.6)
T22	4.26 (108.2)
T23	5.26 (133.6)

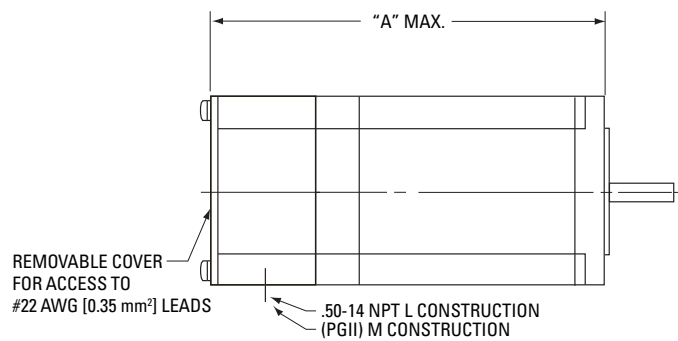

Dimensions in inches [mm]

T2 Series Stepper Motors

T 2 S E R I E S S T E P P E R M O T O R S

T2 Performance Data

Motor Model Number	Config.		Holding Torque (2 phases on) oz-in (Nm) +/-10%	Rated Current/ Phase Amps DC	Phase Resistance Ohms +/-10%	Phase Inductance mH Typical	Detent Torque oz-in (Nm)	Thermal Resistance Mounted °C/Watt	Rotor Inertia oz-in-s ² (kg-m ² x 10 ⁻³)	Weight lb (kg)	Shaft Loading*	
	Parallel	Series									Radial Force lb (N)	Axial Force lb (N)
Short Stack	T2HxxHK	•	74 (0.52)	5.3	0.19	0.63	2.0 (0.014)	6.14	0.00154 (0.0109)	1.1 (0.50)	15 (67)	25 (111)
	T2HxxHJ	•		4.0	0.28	1.0						
	T2HxxLH	•		2.7	0.64	2.5						
	T2HxxLD	•		1.1	3.6	16						
1 Stack	T21xxHK	•	180 (1.27)	5.4	0.23	1.1	3.0 (0.021)	4.64	0.0034 (0.024)	1.5 (0.68)	15 (67)	25 (111)
	T21xxHJ	•		4.1	0.33	1.8						
	T21xxLC	•		0.4	42.9	209						
	T21xxLH	•		2.7	0.85	4.6						
	T21xxLE	•		1.4	3.0	16						
	T21xxLD	•		1.1	4.9	30						
2 Stack	T22xxHK	•	280 (1.98)	6.6	0.20	0.85	6.0 (0.042)	3.69	0.0056 (0.040)	2.2 (1.0)	15 (67)	25 (111)
	T22xxHJ	•		4.1	0.49	2.5						
	T22xxLC	•		0.46	41.4	209						
	T22xxLH	•		3.3	0.75	3.4						
	T22xxLG	•		2.5	1.3	7.1						
	T22xxLE	•		1.5	2.9	17						
3 Stack	T23xxHK	•	380 (2.68)	6.0	0.28	1.5	7.0 (0.049)	3.04	0.0084 (0.059)	3.3 (1.5)	15 (67)	25 (111)
	T23xxHJ	•		3.8	0.64	3.9						
	T23xxLC	•		0.67	23.5	136						
	T23xxLH	•		3.0	1.0	6.2						
	T23xxLF	•		1.8	2.8	17						
	T23xxLE	•		1.5	4.1	24						

Note: *Maximum shaft loading based on 20,000 hours of operation at 1500 rpm.
See page 88 for T series connector diagrams and switching sequence.

T2 Performance Curves - DC Drive Models

T21xxLH w/ P70530

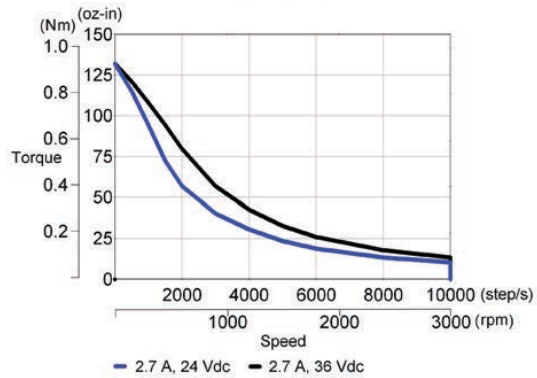

T2 Performance Curves - AC Drive Models

T21xxLC w/ P70360

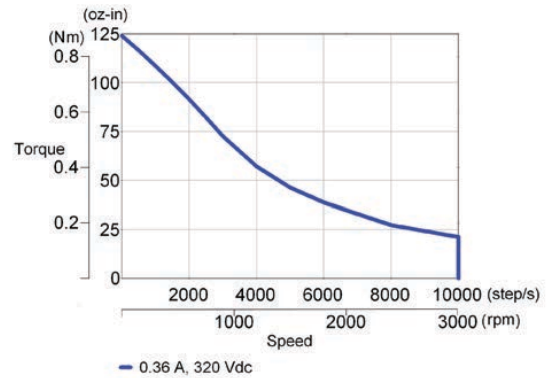

T22xxLG w/ P70530

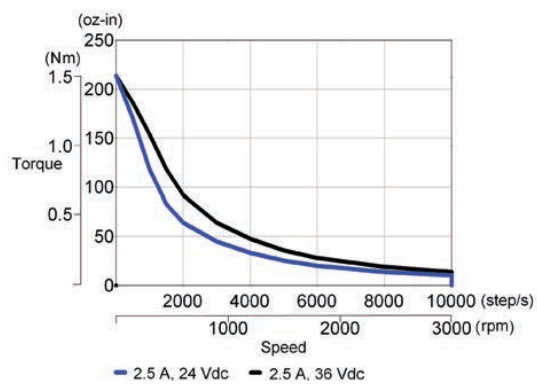

T22xxLC w/ P70360

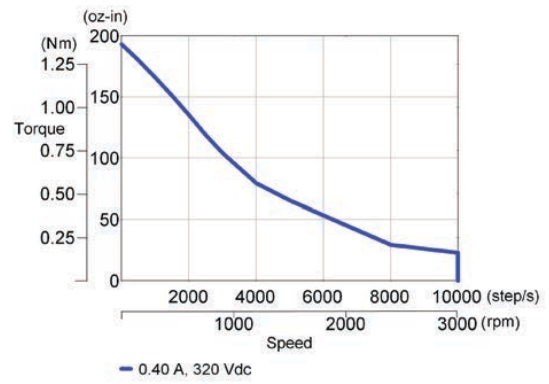

T23xxLH w/ P70530

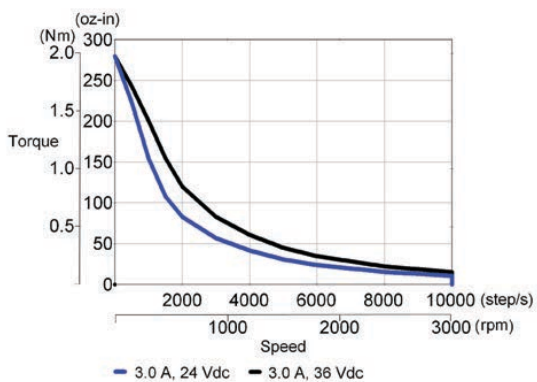

T23xxLC w/ P70360

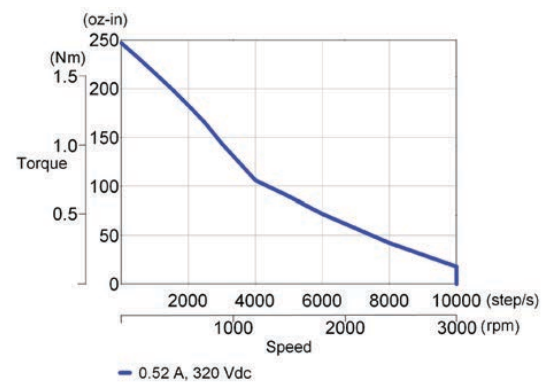

M2 / P2 Series Stepper Motors

General Specifications

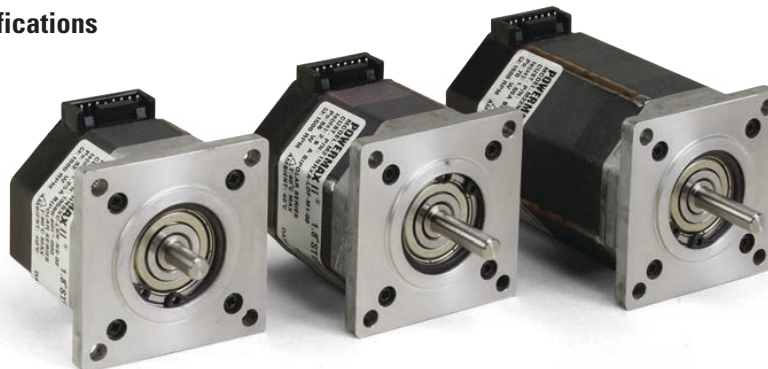

- NEMA Size 23
- Standard (P) and enhanced (M) using SIGMAX technology
- Standard laminated and low inertia “-J” rotors for maximum acceleration
- Standard NEMA mounting
- Oversized 30 mm bearings
- CE compliant
- Unipolar or Bipolar windings
- Features: integral electrical receptacle, smooth or flat shaft
- Options: leadwire connection, rear shaft extension, encoder mounting provisions, 500 or 512 ppr encoder
- Custom Motors

Phases	2 and 4
Full Steps per Revolution	200
Step Angle	1.8°
Step Accuracy (of one full step, no load)	± 1.5 % M ± 3 % P
Operating Temperature	-20°C to +40°C
Insulation Class	Class B, 130°C
Insulation Voltage Rating	340 Vdc
Insulation Resistance	100 Megohms

Rotor Inertia Characteristics

Single and double stack motors are available with both standard and low inertia “-J” rotors. Choose low inertia to produce the highest acceleration rates possible. Low inertia motors are most effective for operation below 2,000 RPM. Choose standard to generate maximum torque.

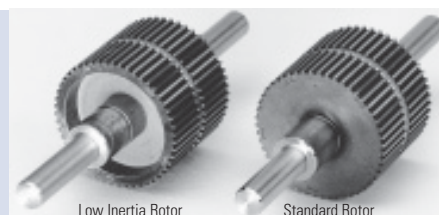

Low Inertia Rotor

Standard Rotor

M2 / P2 Series Outline Drawings

M2 / P2 Regular Construction Hookup

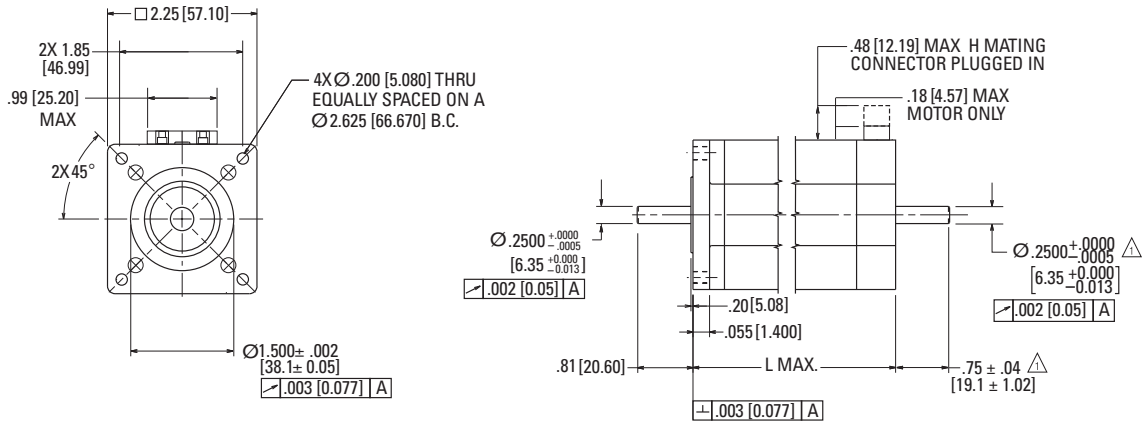

Motor Model	L Max.
P2H	1.60 [40.7]
P or M21	2.06 [52.3]
P or M22	3.10 [78.7]

Dimensions in inches [mm]

Standard Shaft Options

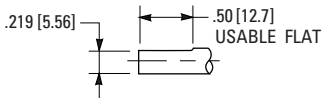

△ Optional rear shaft extension available as shown. Same diameter as front shaft extension.

1. Shaft modifications also available.
2. Optional flat available on front shaft as shown.

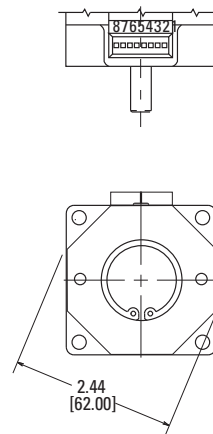

Encoder Option

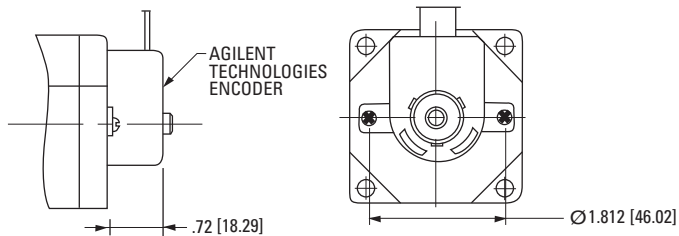

Dimensions in inches [mm]

M2 / P2 Series Stepper Motors

M 2 / P 2 S E R I E S S T E P P E R M O T O R S

M2 / P2 Performance Data

	Motor Model Number	Config.			Holding Torque (2 phases on) oz-in (Nm) +/-10%	Rated Current/ Phase Amps DC	Phase Resistance Ohms +/-10%	Phase Inductance mH Typical	Detent Torque oz-in (Nm)	Thermal Resistance Mounted °C/Watt	Rotor Inertia oz-in-s ² (kg-m ² x10 ⁻³)	Weight lb (kg)	Shaft Loading*								
		Parallel	Series	Unipolar									Radial Force lb (N)	Axial Force lb (N)							
															lb (N)	lb (N)					
Short Stack	P2HxxxH-L	•			59 (0.42)	5.2	0.22	0.50	2.5 (0.018)	6.6	0.0010 (0.0071)	1.0 (0.45)	20 (89)	13 (58)							
	P2HxxxH-L		•			2.6	0.90	1.9													
	P2HxxxB-L	•				2.6	0.76	1.9													
	P2HxxxB-L		•		59 (0.42)	1.3	3.04	7.6													
	P2HxxxC-L	•				2.5	0.84	2.3													
	P2HxxxC-L		•		61 (0.43)	1.25	3.36	9.2													
	P2HxxxF-L	•				1.61	1.92	5.1													
	P2HxxxF-L		•		60 (0.42)	0.8	7.68	20.4													
	P2HxxxH-L			•		3.68	0.44	0.50													
	P2HxxxB-L			•	42 (0.30)	1.84	1.52	1.9													
	P2HxxxC-L			•		43 (0.30)	1.77	1.68							2.3						
	P2HxxxF-L			•	42 (0.30)	1.1	3.84	5.1													
1 Stack	P21xxxA-L	•			114 (0.81)	5.6	0.23	0.80	4.0 (0.028)	5.5	0.0017 (0.012)	1.5 (0.68)	20 (89)	13 (58)							
	P21xxxA-L		•			2.8	0.92	3.2													
	P21xxxB-L	•			111 (0.78)	4.6	0.32	1.1													
	P21xxxB-L		•			2.3	1.28	4.4													
	P21xxxC-L	•			116 (0.82)	3.5	0.53	2.3													
	P21xxxC-L		•			1.75	2.12	9.2													
	P21xxxD-L	•			109 (0.77)	1.51	2.61	10.3													
	P21xxxD-L		•			0.76	10.4	41.2													
	P21xxxA-L			•	81 (0.57)	4.0	0.46	0.80													
	P21xxxB-L			•	79 (0.56)	3.3	0.64	1.1													
	P21xxxC-L			•	82 (0.58)	2.5	1.06	2.3													
	P21xxxD-L			•	77 (0.54)	1.07	5.22	10.3													
	Low Inertia	P21xxxA-J	•			111 (0.78)	5.6	0.23							0.90	0.0013 (0.0092)					
		P21xxxA-J		•			2.8	0.92							3.6						
P21xxxA-J				•	79 (0.56)		4.0	0.46	0.90												
Enhanced 1 Stack	M21xxxA-L	•			142 (1.00)	5.6	0.23	0.70	9.4 (0.66)	5.5	0.0017 (0.012)	1.5 (0.68)	20 (89)	13 (58)							
	M21xxxA-L		•			2.8	0.92	2.8													
	M21xxxB-L	•			137 (0.97)	4.6	0.32	1.0													
	M21xxxB-L		•			2.3	1.28	4.0													
	M21xxxC-L	•			144 (1.02)	3.5	0.53	2.0													
	M21xxxC-L		•			1.75	2.12	8.0													
	M21xxxD-L	•			135 (0.95)	1.51	2.61	8.7													
	M21xxxD-L		•			0.76	10.4	34.8													
	M21xxxA-L			•	100 (0.71)	4.0	0.46	0.70													
	M21xxxB-L			•	97 (0.68)	3.3	0.64	1.0													
	M21xxxC-L			•	102 (0.72)	2.5	1.06	2.0													
	M21xxxD-L			•	95 (0.67)	1.07	5.22	8.7													
Low Inertia	M21xxxA-J	•			140 (0.99)	5.6	0.23	0.70	0.0013 (0.0092)												
	M21xxxA-J		•			2.8	0.92	2.8													
	M21xxxA-J			•		99 (0.70)	4.0	0.46							0.70						

Note: *Maximum shaft loading based on 20,000 hours of operation at 1500 rpm.

Continued on page 45.

M2 / P2 Performance Data (continued)

	Motor Model Number	Config.			Holding Torque (2 phases on)	Rated Current/ Phase	Phase Resistance	Phase Inductance	Detent Torque	Thermal Resistance	Rotor Inertia	Weight	Shaft Loading*	
		Parallel	Series	Unipolar									oz-in (Nm) +/-10%	Amps DC
					lb (N)	lb (N)								
2 Stack	P22xxxA-L	•			197 (1.39)	6.5	0.21	0.80	17 (0.12)	4.5	0.0036 (0.025)	2.5 (1.13)	20 (89)	13 (58)
	P22xxxA-L		•			3.3	0.84	3.2						
	P22xxxB-L	•			214 (1.51)	4.6	0.38	2.1						
	P22xxxB-L		•			2.3	1.52	8.4						
	P22xxxC-L	•			203 (1.43)	3.1	0.78	3.9						
	P22xxxC-L		•			1.55	3.12	15.6						
	P22xxxD-L	•			203 (1.43)	2.5	1.22	6.2						
	P22xxxD-L		•			1.25	4.88	24.8						
	P22xxxE-L	•			195 (1.38)	1.64	2.7	12.6						
	P22xxxE-L		•			0.82	10.8	50.4						
	P22xxxA-L			•	139 (0.98)	4.6	0.42	0.80						
	P22xxxB-L			•	151 (1.07)	3.3	0.76	2.1						
	P22xxxC-L			•	144 (1.01)	2.2	1.56	3.9						
	P22xxxD-L			•	144 (1.01)	1.77	2.44	6.2						
P22xxxE-L			•	138 (0.97)	1.16	5.4	12.6							
Low Inertia	P22xxxB-J	•			201 (1.42)	4.6	0.38	1.8	17 (0.12)	4.5	0.0026 (0.018)	2.5 (1.13)	20 (89)	13 (58)
	P22xxxB-J		•			2.3	1.52	7.2						
	P22xxxB-J			•	142 (1.00)	3.3	0.76	1.8						
Enhanced 2 Stack	M22xxxA-L	•			230 (1.62)	6.5	0.21	0.70	17 (0.12)	4.5	0.0036 (0.025)	2.5 (1.13)	20 (89)	13 (58)
	M22xxxA-L		•			3.3	0.84	2.8						
	M22xxxB-L	•			253 (1.79)	4.6	0.38	1.7						
	M22xxxB-L		•			2.3	1.52	6.8						
	M22xxxC-L	•			238 (1.68)	3.1	0.78	3.1						
	M22xxxC-L		•			1.55	3.12	12.4						
	M22xxxD-L	•			238 (1.68)	2.5	1.22	5.0						
	M22xxxD-L		•			1.25	4.88	20						
	M22xxxE-L	•			227 (1.60)	1.64	2.71	10.1						
	M22xxxE-L		•			0.82	10.8	40.4						
	M22xxxA-L			•	163 (1.15)	4.6	0.42	0.70						
	M22xxxB-L			•	179 (1.26)	3.3	0.76	1.7						
	M22xxxC-L			•	168 (1.19)	2.2	1.56	3.1						
	M22xxxD-L			•	168 (1.19)	1.77	2.44	5.0						
M22xxxE-L			•	161 (1.14)	1.16	5.42	10.1							
Low Inertia	M22xxxB-J	•			252 (1.78)	4.6	0.38	1.5	17 (0.12)	4.5	0.0026 (0.018)	2.5 (1.13)	20 (89)	13 (58)
	M22xxxB-J		•			2.3	1.52	6.0						
	M22xxxB-J			•	178 (1.26)	3.3	0.76	1.5						

Note: *Maximum shaft loading based on 20,000 hours of operation at 1500 rpm.
See page 91 for M&P series connector diagrams and switching sequence.

M2 / P2 Series Stepper Motors

M 2 / P 2 S E R I E S S T E P P E R M O T O R S

M2 / P2 Performance Curves

P2HxxxF-L (S) w/ P5000

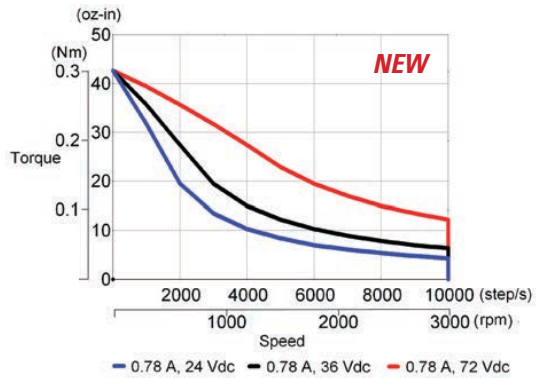

P2HxxxF-L (P) w/ P5000

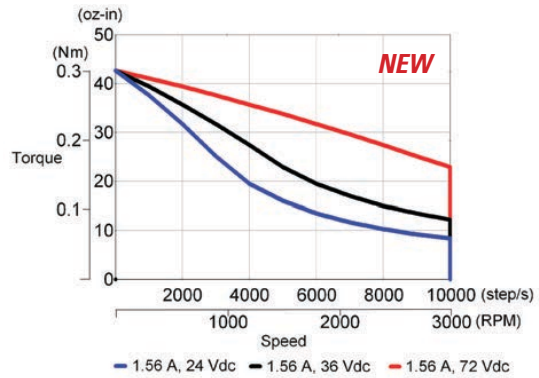

P2HxxxB-L (S) w/ P5000

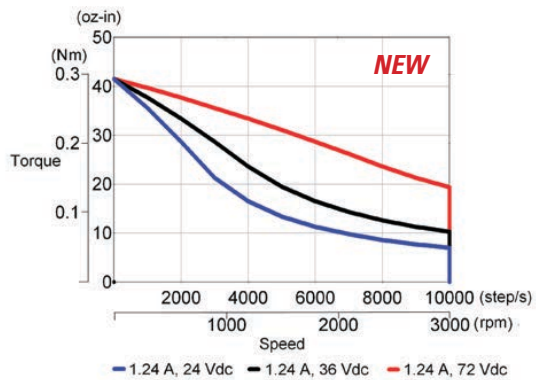

P2HxxxB-L (P) w/ P5000

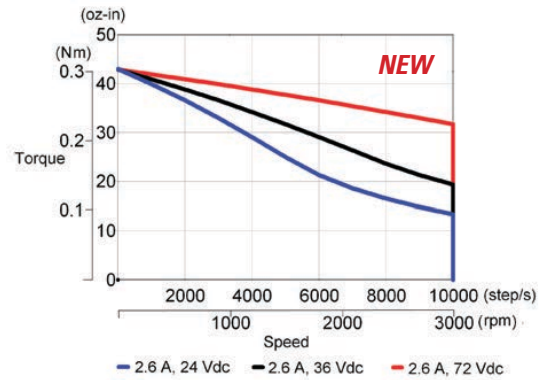

P21xxxD-L (P) w/ P5000

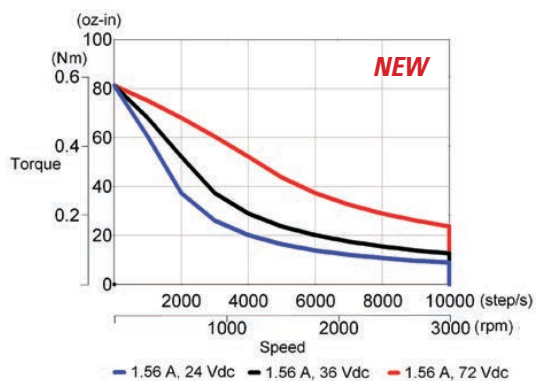

M21xxxD-L (P) w/ P5000

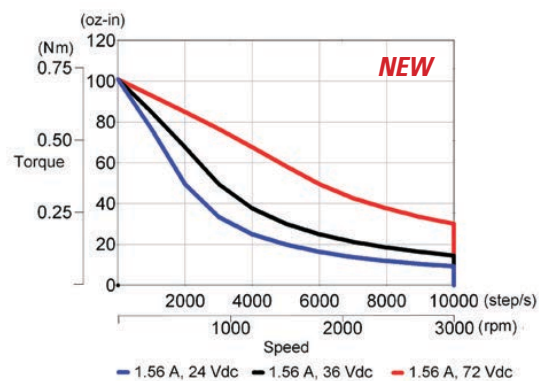

M2 / P2 Performance Curves

P21xxxA-L (S) w/ P5000

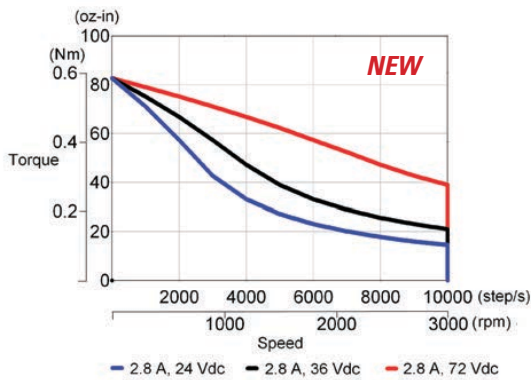

M21xxxA-L (S) w/ P5000

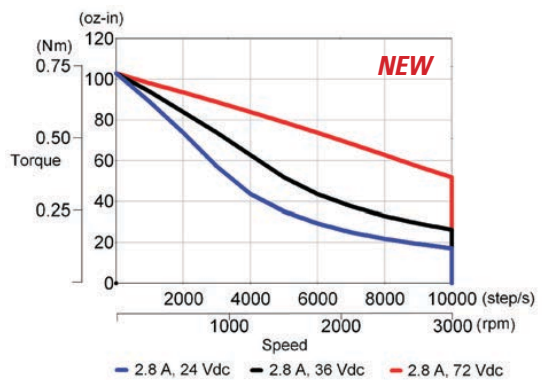

P22xxxE-L (S) w/ P5000

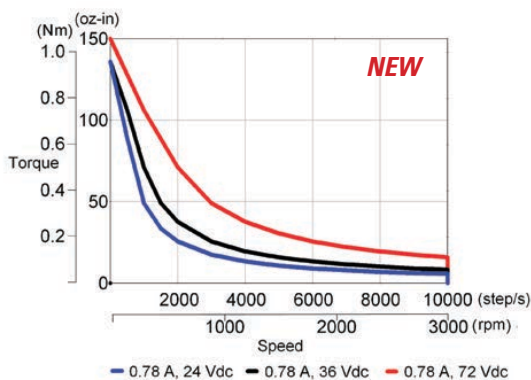

M22xxxE-L (S) w/ P5000

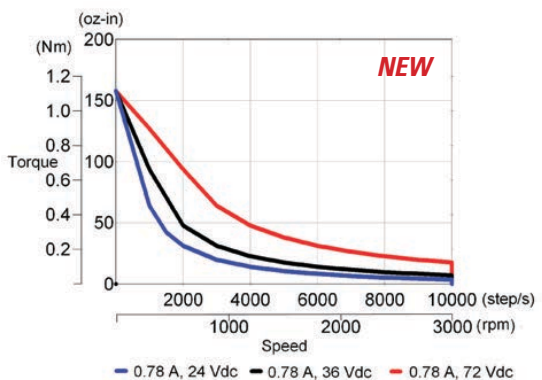

P22xxxC-L (S) w/ P5000

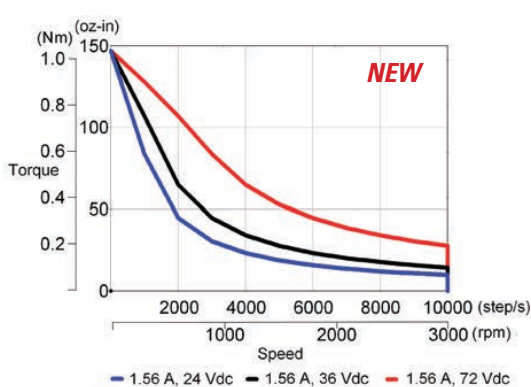

M22xxxC-L (S) w/ P5000

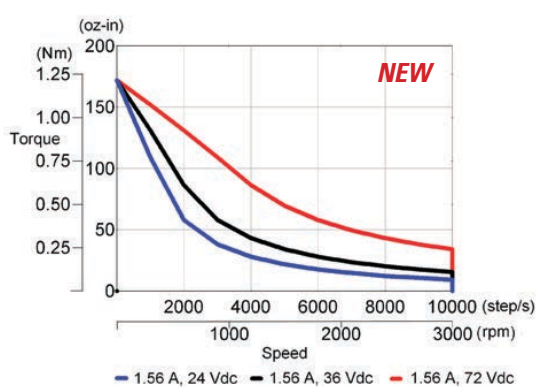

M2 / P2 Series Stepper Motors

M 2 / P 2 S E R I E S S T E P P E R M O T O R S

M2 / P2 Performance Curves

P22xxxD-L (P) w/ P5000

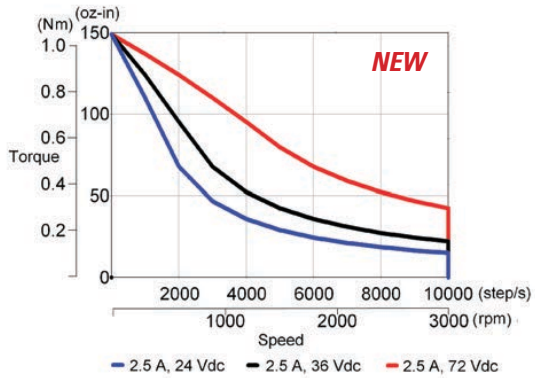

M22xxxD-L (P) w/ P5000

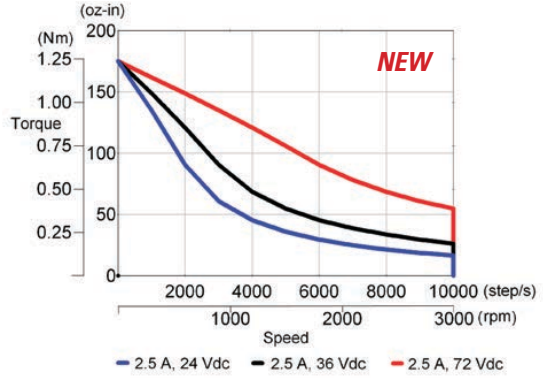

P21xxxD-L (P) w/ P6000

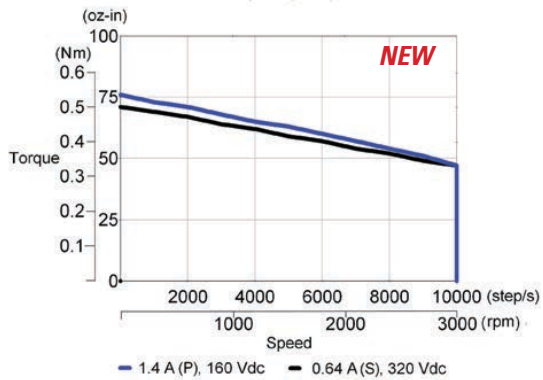

M21xxxD-L (P) w/ P6000

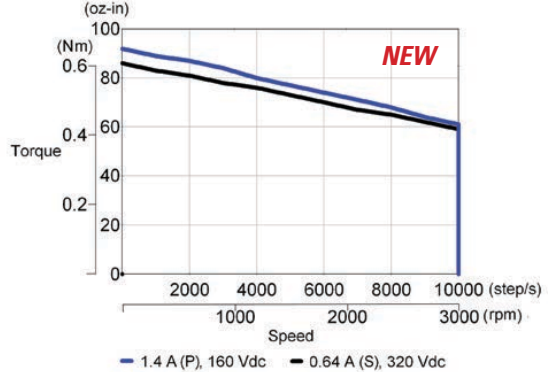

Sold & Serviced By:



Toll Free Phone (877) SERV098

Toll Free Fax (877) SERV099

www.electromate.com

sales@electromate.com

Notes

A large rectangular area filled with a light blue grid pattern, intended for handwritten notes.

K / N Series Stepper Motors

K / N SERIES STEPPER MOTORS

General Specifications

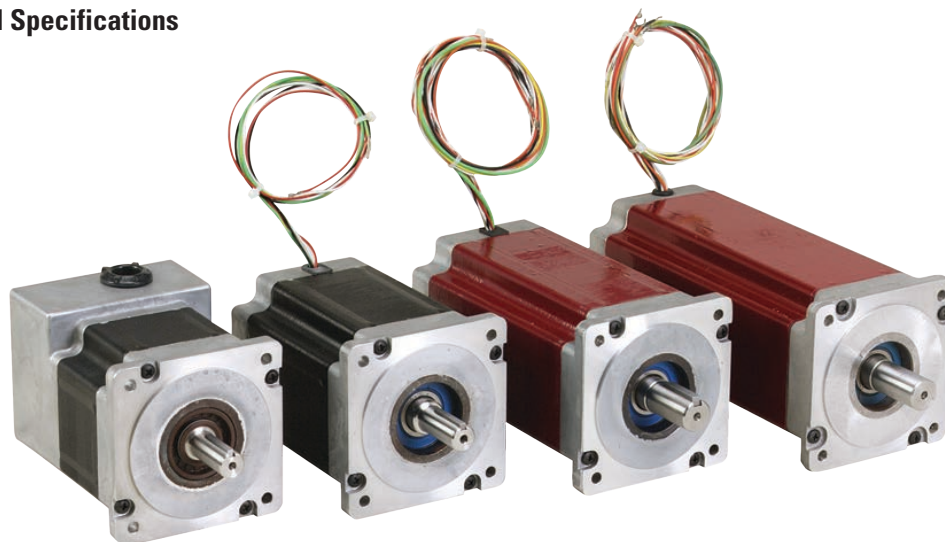

- NEMA Sizes 34, 42
- Standard (N) and enhanced (K) using SIGMAX technology
- Standard NEMA mounting
- CE and cUR compliant
- Unipolar or Bipolar windings
- Features: leadwire connection, straight keyway
- Options: splash-proof terminal board, MS connector, rear shaft extension, provision for encoder, shaft seal
- Custom Motors

Phases	2 and 4
Full Steps per Revolution	200
Step Angle	1.8°
Step Accuracy (of one full step, no load)	± 1.5 % K3, K4 ± 3 % N3, N4
Operating Temperature	-20°C to +40°C
Insulation Class	Class B, 130°C
Insulation Voltage Rating	340 Vdc
Insulation Resistance	100 Megohms

K3 / N3 Outline Drawings

Leadwire Hookup

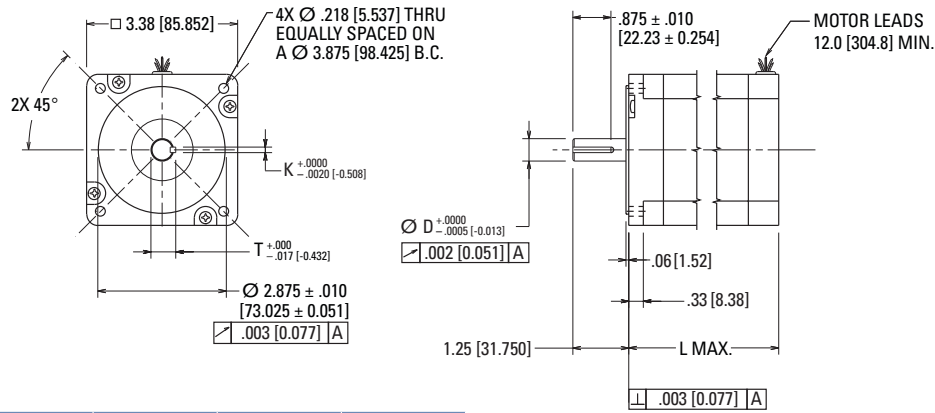

Model	"D"	"K"	"T"	"L" MAX
31HR	0.5000 (12.700)	0.1250 (3.175)	0.555 (14.097)	3.13 (79.502)
32HR				4.65 (118.11)
33HR	0.6250 (15.875)	0.1875 (4.763)	0.705 (17.907)	6.13 (155.70)
34HR				7.68 (195.07)

Dimensions in inches [mm]

Double Shaft Configuration

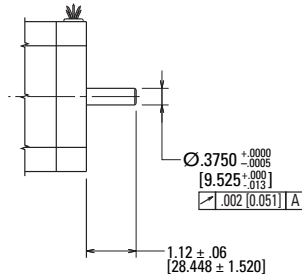

Encoder Mounting Provision

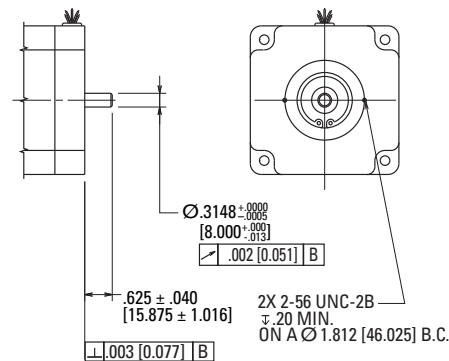

Dimensions in inches [mm]

K / N Series Stepper Motors

K / N SERIES STEPPER MOTORS

K3 / N3 Outline Drawings

Splashproof Construction / Terminal Board Connections

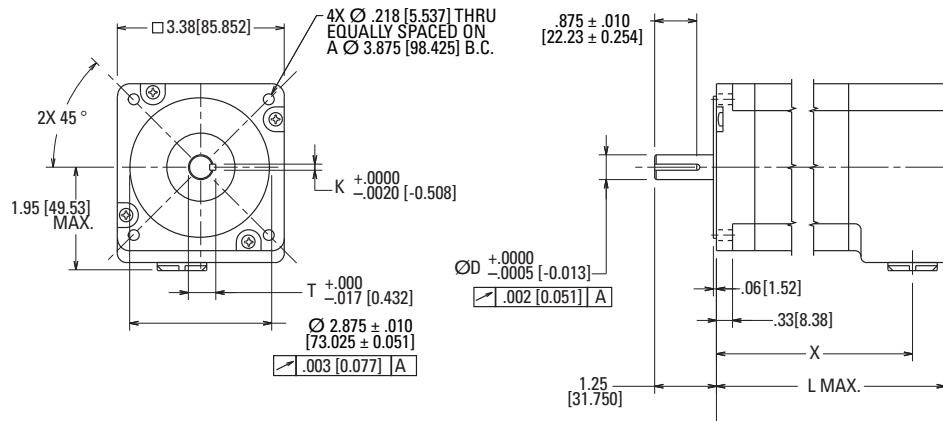

Dimensions in inches [mm]

Model	"D"	"K"	"T"	"X"	"L" MAX
31HL	0.5000 (12.700)	0.1250 (3.175)	0.555 (14.097)	3.70 (93.98)	4.44 (112.78)
32HL				5.22 (132.59)	5.96 (151.38)
33HL	0.6250 (15.875)	0.1875 (4.763)	0.705 (17.907)	6.74 (171.20)	7.48 (189.99)
34HL				8.25 (209.55)	8.99 (228.35)

K3 / N3 Outline Drawings

Splashproof Construction / MS Connector(s)

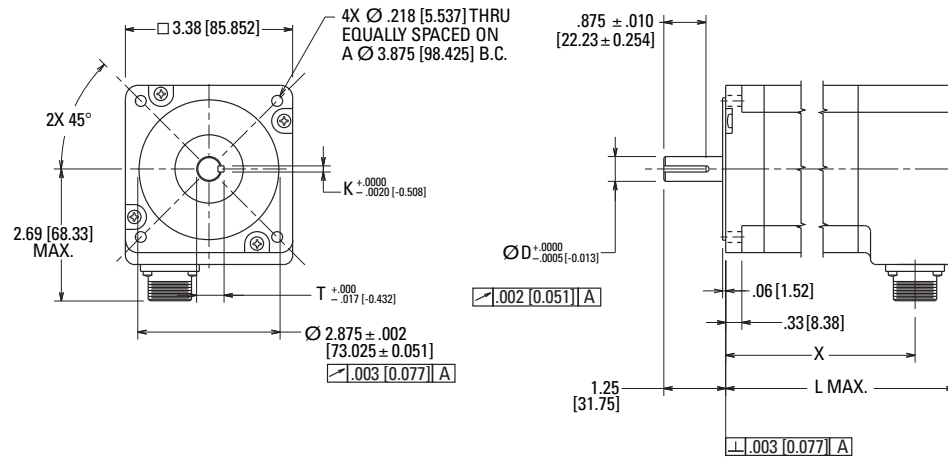

Dimensions in inches [mm]

Model	"D"	"K"	"T"	"X"	"L" MAX
31HC	0.5000 (12.700)	0.1250 (3.175)	0.555 (14.097)	3.56 (90.42)	4.44 (112.78)
32HC				5.07 (128.78)	5.96 (151.38)
33HC	0.6250 (15.875)	0.1875 (4.763)	0.705 (17.907)	6.59 (165.10)	7.48 (189.99)
34HC				8.11 (205.99)	8.99 (228.35)

Encoder Mounting Option

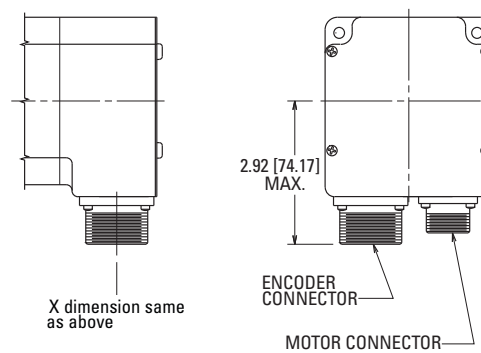

Dimensions in inches [mm]

K / N Series Stepper Motors

K / N SERIES STEPPER MOTORS

K4 / N4 Outline Drawings

Regular Leadwire Hookup

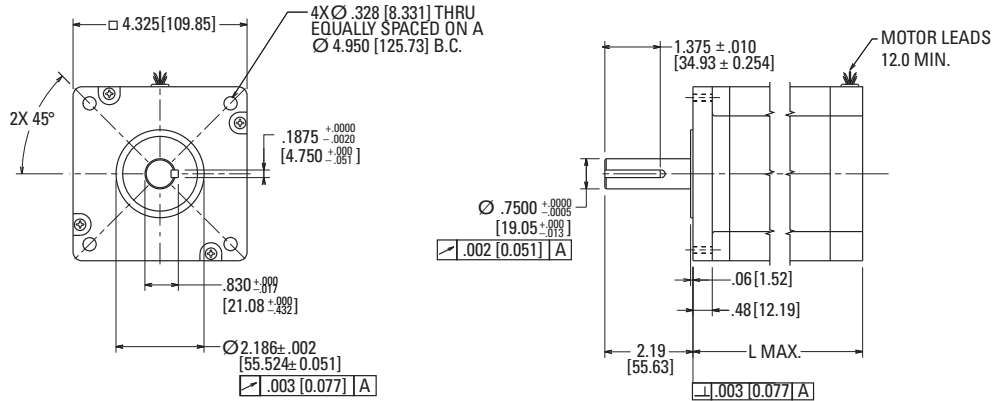

Model	"L" MAX
41HR	3.89 (98.81)
42HR	5.91 (150.11)
43HR	7.92 (201.17)

Dimensions in inches [mm]

Splashproof Construction / Terminal Board Connections

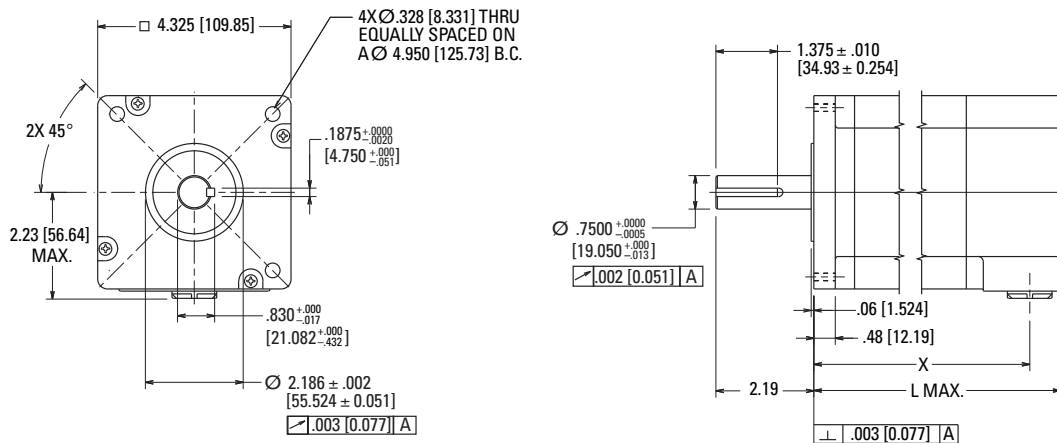

Model	"X"	"L" MAX
41HL	4.46 (113.28)	5.20 (132.08)
42HL	6.48 (164.59)	7.22 (183.39)
43HL	8.49 (215.65)	9.23 (234.44)

Dimensions in inches [mm]

K4 / N4 Outline Drawings

Splashproof Construction / MS Connector(s)

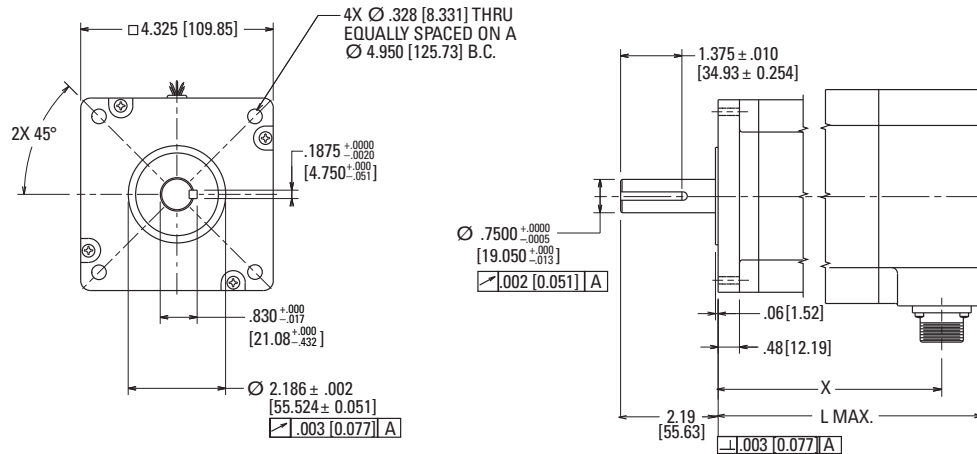

Model	"X"	"L" MAX
41HC	4.32 (109.73)	5.20 (132.08)
42HC	6.33 (160.78)	7.22 (183.39)
43HC	8.35 (212.09)	9.23 (234.44)

Dimensions in inches [mm]

K / N Series Stepper Motors

K / N SERIES STEPPER MOTORS

K3 / N3 Performance Data

	Motor Model Number	Config.			Holding Torque (2 phases on) oz-in (Nm) +/-10%	Rated Current/Phase Amps DC	Phase Resistance Ohms +/-10%	Phase Inductance mH Typical	Detent Torque oz-in (Nm)	Thermal Resistance Mounted °C/Watt	Rotor Inertia oz-in-s ² (kg-m ² x 10 ⁻³)	Weight lb (kg)	Shaft Loading	
		Parallel	Series	Unipolar									Radial Force lb (N)	Axial Force lb (N)
1 Stack	N31xxHL-L	•			650 (4.59)	8.6	0.18	1.4	18 (0.13)	2.7	0.0202 (0.14)	5.0 (2.3)	65 (289)	305 (1360)
	N31xxLL-L		•			4.3	0.72	5.8						
	N31xxHK-L	•			665 (4.69)	6.6	0.29	2.6						
	N31xxLK-L		•			3.3	1.16	10.3						
	N31xxHJ-L	•			645 (4.55)	5.5	0.42	3.5						
	N31xxLJ-L		•			2.7	1.69	14						
	N31xxHH-L	•			635 (4.48)	2.8	1.55	12.5						
	N31xxLH-L		•			1.4	6.21	50.1						
	N31xxLG-L	•			641 (4.52)	1.73	4.06	34.5						
	N31xxHG-L		•			0.86	16.2	138						
	N31xxEL-L			•	460 (3.25)	6.1	0.36	1.4						
	N31xxEK-L			•	470 (3.32)	4.7	0.58	2.6						
	N31xxEJ-L			•	455 (3.21)	3.9	0.84	3.5						
	N31xxEH-L			•	450 (3.18)	2.0	3.10	12.5						
N31xxEG-L			•	453 (3.20)	1.22	8.12	34.5							
Enhanced 1 Stack	K31xxHL-L	•			830 (5.86)	8.6	0.18	1.2	25 (0.18)	2.7	0.0202 (0.14)	5.0 (2.3)	65 (289)	305 (1360)
	K31xxLL-L		•			4.3	0.72	4.7						
	K31xxHK-L	•			845 (5.96)	6.6	0.29	2.1						
	K31xxLK-L		•			3.3	1.16	8.3						
	K31xxHJ-L	•			820 (5.79)	5.5	0.42	2.8						
	K31xxLJ-L		•			2.7	1.69	11.4						
	K31xxHH-L	•			805 (5.68)	2.8	1.55	10.2						
	K31xxLH-L		•			1.4	6.21	40.7						
	K31xxLG-L	•			816 (5.76)	1.73	4.06	28.1						
	K31xxLG-L		•			0.86	16.2	112						
	K31xxEL-L			•	590 (4.16)	6.1	0.36	1.2						
	K31xxEK-L			•	600 (4.23)	4.7	0.58	2.1						
	K31xxEJ-L			•	580 (4.09)	3.9	0.84	2.8						
	K31xxEH-L			•	570 (4.03)	2.0	3.10	10.2						
K31xxEG-L			•	577 (4.08)	1.22	8.12	28.1							
2 Stack	N32xxHD-L	•			1195 (8.45)	3.2	1.57	16.5	36 (0.25)	2.0	0.038 (0.27)	8.4 (3.8)	65 (289)	305 (1360)
	N32xxLD-L		•			1.6	6.30	66.1						
	N32xxHM-L	•			1215 (8.58)	10	0.18	1.8						
	N32xxLM-L		•			5.0	0.70	7.0						
	N32xxHL-L	•			1200 (8.47)	8.1	0.26	2.6						
	N32xxLL-L		•			4.1	1.03	10.3						
	N32xxHK-L	•			1245 (8.79)	6.1	0.45	5.1						
	N32xxLK-L		•			3.0	1.80	20.6						
	N32xxHJ-L	•			1195 (8.43)	5.1	0.63	6.5						
	N32xxLJ-L		•			2.5	2.53	26						
	N32xxLG-L	•			1240 (8.76)	1.91	4.41	51.6						
	N32xxHG-L		•			0.95	17.6	206						
	N32xxED-L			•	845 (5.97)	2.3	3.15	16.5						
	N32xxEM-L			•	860 (6.07)	7.1	0.35	1.8						
	N32xxEL-L			•	850 (6.00)	5.8	0.52	2.6						
	N32xxEK-L			•	885 (6.25)	4.3	0.90	5.1						
	N32xxEJ-L			•	845 (5.96)	3.5	1.27	6.5						
	N32xxEG-L			•	887 (6.19)	1.35	8.82	51.6						

Note: See page 88 for K&N series connection diagrams and switching sequence.

Continued on page 57.

K3 / N3 Performance Data (continued)

	Motor Model Number	Config.			Holding Torque (2 phases on)	Rated Current/Phase	Phase Resistance	Phase Inductance	Detent Torque	Thermal Resistance	Rotor Inertia	Weight	Shaft Loading*	
		Parallel	Series	Unipolar									oz-in (Nm) +/-10%	Amps DC
					lb (N)	lb (N)								
Enhanced 2 Stack	K32xxHD-L	•			1510 (10.7)	3.2	1.57	13.0	50 (0.35)	2.0	0.038 (0.27)	8.4 (3.8)	65 (289)	305 (1360)
	K32xxLD-L		•			1.6	6.30	51.9						
	K32xxHM-L	•			1535 (10.8)	10	0.18	1.4						
	K32xxHL-L		•			5.0	0.70	5.5						
	K32xxLL-L			•	1515 (10.7)	8.1	0.26	2.0						
	K32xxLK-L	•				4.1	1.03	8.1						
	K32xxLJ-L	•			1580 (11.2)	6.1	0.45	4.0						
	K32xxLG-L		•			3.0	1.8	16.2						
	K32xxLH-L	•			1510 (10.7)	5.1	0.63	5.1						
	K32xxLJ-L		•			2.5	2.53	20.5						
	K32xxLG-L	•			1570 (11.1)	1.91	4.41	51.6						
	K32xxHG-L		•			0.95	17.6	162						
	K32xxED-L			•	1065 (7.53)	2.3	3.15	13.0						
	K32xxEM-L			•	1085 (7.66)	7.1	0.35	1.4						
	K32xxEL-L			•	1070 (7.55)	5.8	0.52	2.0						
	K32xxEK-L			•	1120 (7.90)	4.3	0.90	4.0						
K32xxEJ-L			•	1065 (7.52)	3.5	1.27	5.1							
K32xxEG-L			•	1110 (7.85)	1.35	8.82	40.5							
3 Stack	N33xxHE-L	•			1700 (12.0)	4.0	1.27	13.6	54 (0.38)	1.6	0.0567 (0.40)	11.9 (5.39)	65 (289)	305 (1360)
	N33xxLE-L		•			2.0	5.06	54.5						
	N33xxHM-L	•			1715 (12.1)	9.9	0.22	2.3						
	N33xxLM-L		•			5.0	0.87	9.0						
	N33xxHL-L	•			1845 (13.0)	9.0	0.26	3.4						
	N33xxLL-L		•			4.5	1.06	13.6						
	N33xxLK-L	•			1755 (12.4)	6.1	0.56	6.4						
	N33xxLJ-L		•			3.0	2.23	25.8						
	N33xxLH-L	•			1710 (12.1)	5.0	0.83	9.0						
	N33xxLG-L		•			2.5	3.31	36						
	N33xxHG-L	•			1710 (12.1)	2.50	3.25	36						
	N33xxEE-L		•			1.24	13.1	144						
	N33xxEM-L			•	1200 (8.47)	2.8	2.53	13.6						
	N33xxEL-L			•	1215 (8.58)	7.0	0.44	2.3						
	N33xxEK-L			•	1305 (9.21)	6.3	0.53	3.4						
	N33xxEJ-L			•	1240 (8.75)	4.3	1.12	6.4						
	N33xxEG-L			•	1210 (8.54)	3.5	1.65	9.0						
	N33xxEG-L			•	1210 (8.55)	1.75	6.51	36						
Enhanced 3 Stack	K33xxHE-L	•			2125 (15.0)	4.0	1.27	10.6	75 (0.53)	1.6	0.0567 (0.40)	11.9 (5.39)	65 (289)	305 (1360)
	K33xxLE-L		•			2.0	5.06	42.2						
	K33xxHM-L	•			2150 (15.2)	9.9	0.22	1.7						
	K33xxLM-L		•			5.0	0.87	7.0						
	K33xxHL-L	•			2340 (16.5)	9.0	0.26	2.6						
	K33xxLL-L		•			4.5	1.06	10.6						
	K33xxLK-L	•			2205 (15.6)	6.1	0.56	5.0						
	K33xxLJ-L		•			3.0	2.23	19.9						
	K33xxLH-L	•			2145 (15.1)	5.0	0.83	7.0						
	K33xxLG-L		•			2.5	3.31	27.9						
	K33xxHG-L	•			2145 (15.1)	2.5	3.25	27.9						
	K33xxEE-L		•			1.24	13.1	111						
	K33xxEM-L			•	1505 (10.6)	2.8	2.53	10.6						
	K33xxEL-L			•	1520 (10.7)	7.0	0.44	1.7						
	K33xxEK-L			•	1655 (11.7)	6.3	0.53	2.6						
	K33xxEJ-L			•	1560 (11.0)	4.3	1.12	5.0						
	K33xxEG-L			•	1515 (10.7)	3.5	1.65	7.0						
	K33xxEG-L			•	1515 (10.7)	1.75	6.51	27.9						

K / N Series Stepper Motors

K / N SERIES STEPPER MOTORS

K3/N3 Performance Curves

N31xxHJ-L w/ P70530

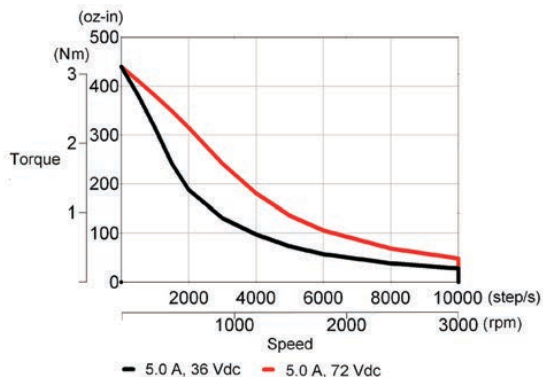

K31xxHJ-L w/ P70530

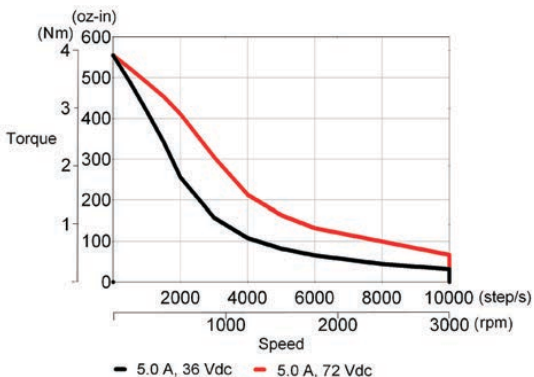

N32xxHJ-L w/ P70530

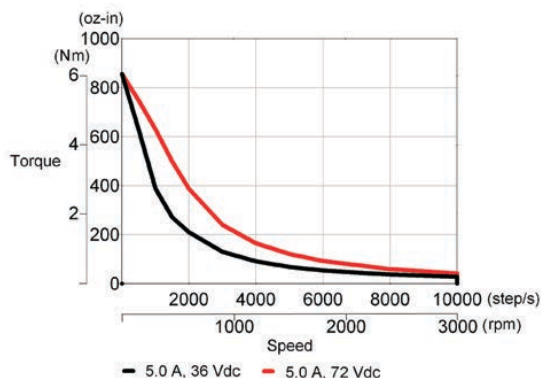

K31xxHJ-L w/ P70530

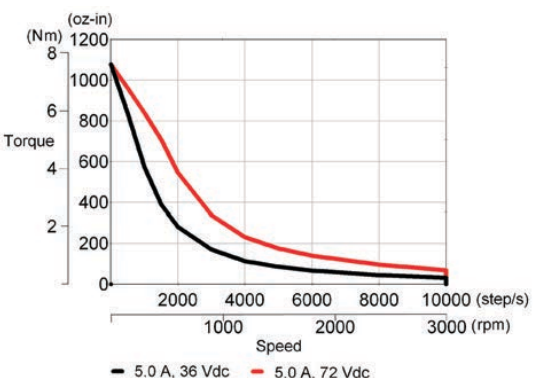

N33xxHJ-L w/ P70530

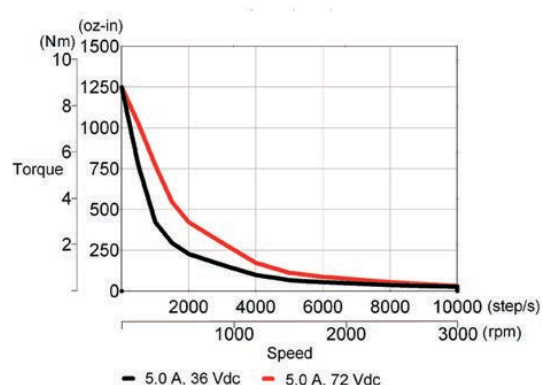

K33xxHJ-L w/ P70530

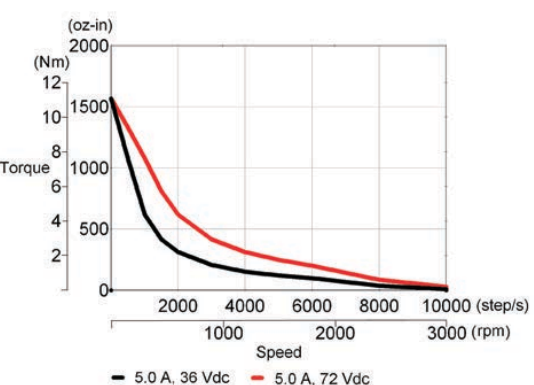

K3/N3 Performance Curves

N34xxHJ-L w/ P70530

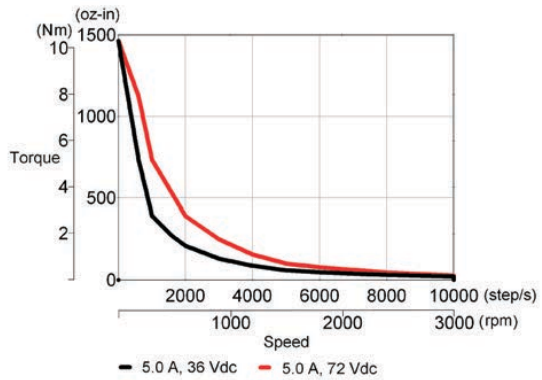

K34xxHJ-L w/ P70530

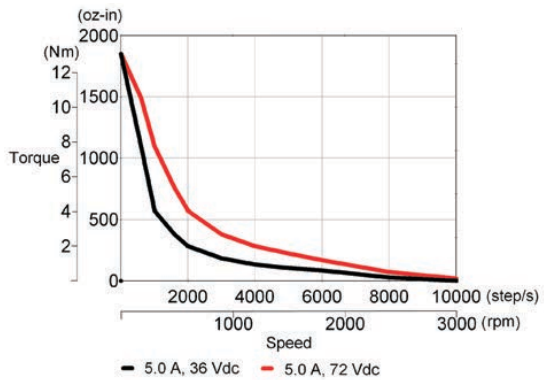

N31xxxH-L w/ P6000

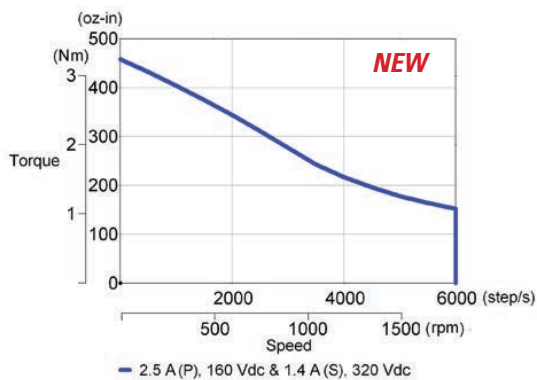

K31xxxH-L w/ P6000

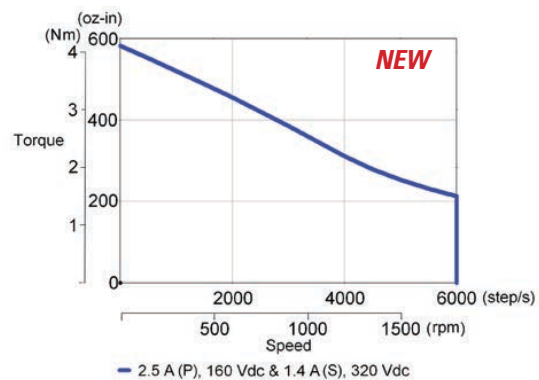

N31xxLG-L w/ P70360

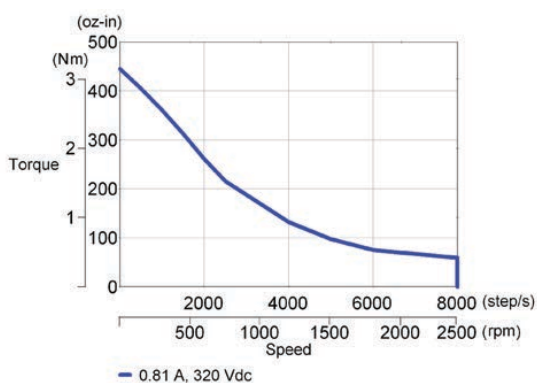

K31xxLG-L (P) w/ P70360

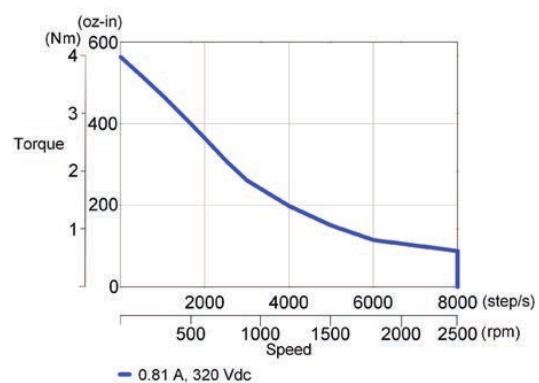

K / N Series Stepper Motors

K / N SERIES STEPPER MOTORS

K3/N3 Performance Curves

N32xxxD-L w/ P6000

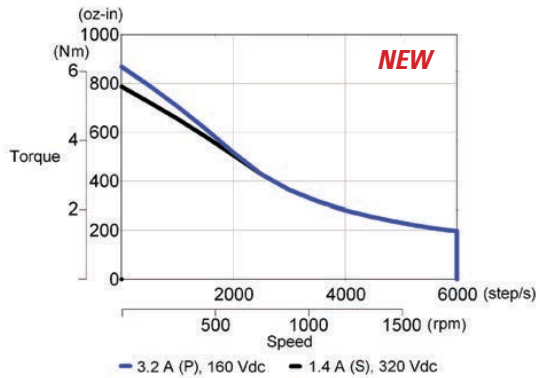

K32xxxD-L w/ P6000

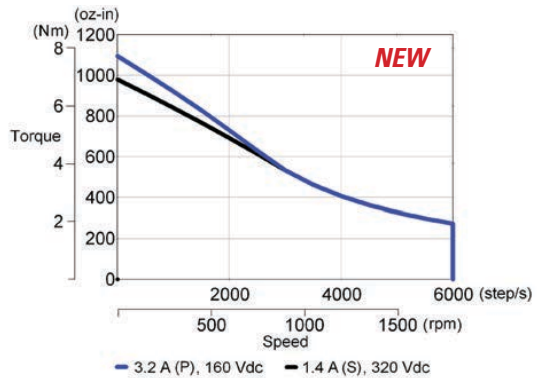

N32xxLG-L w/ P70360

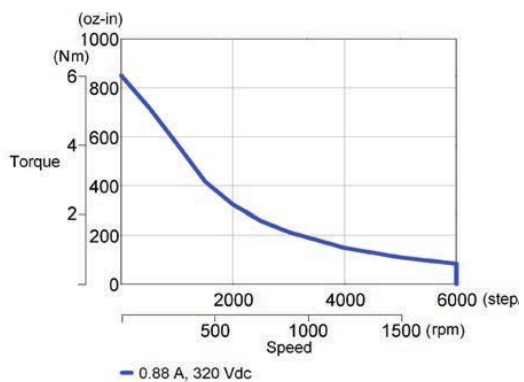

K32xxLG-L w/ P70360

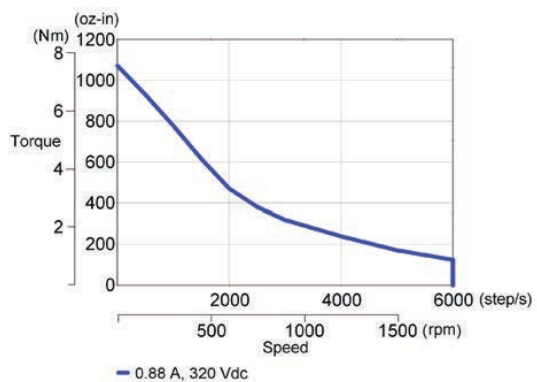

N33xxxE-L w/ P6000

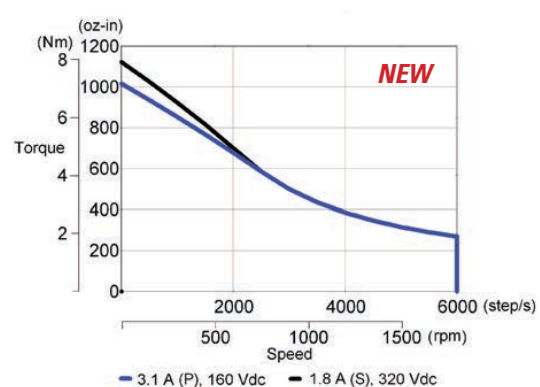

K33xxxE-L w/ P6000

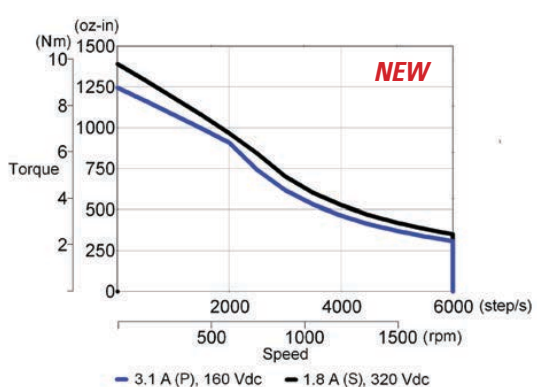

K3/N3 Performance Curves

N33xxLG-L w/ P70360

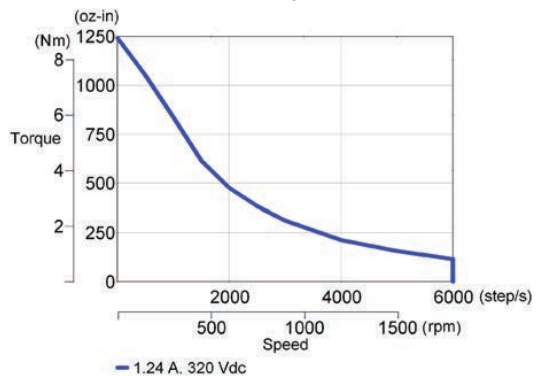

K32xxLG-L w/ P70360

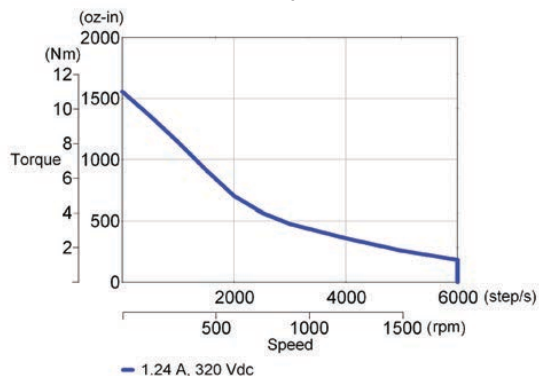

N34xxLG-L w/ P70360

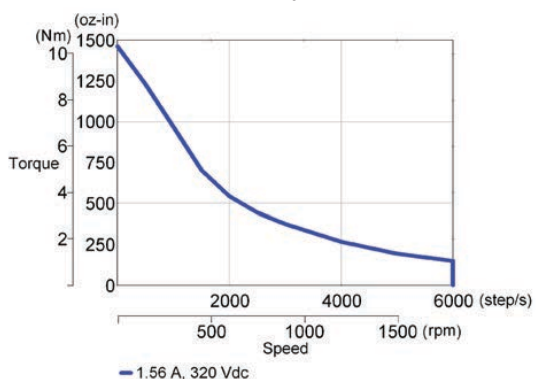

K34xxLG-L w/ P70360

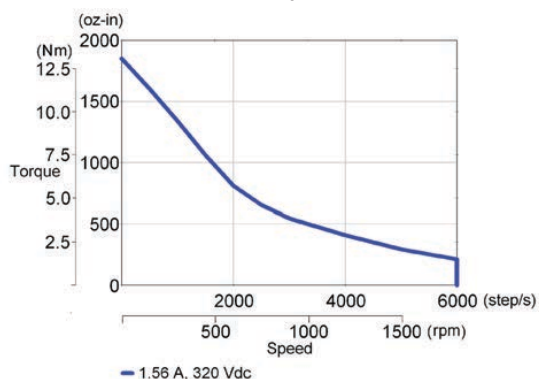

K / N Series Stepper Motors

K / N SERIES STEPPER MOTORS

K4 / N4 Performance Data

	Motor Model Number	Config.			Holding Torque (2 phases on)	Rated Current/ Phase	Phase Resistance	Phase Inductance	Detent Torque	Thermal Resistance	Rotor Inertia	Weight	Shaft Loading	
		Parallel	Series	Unipolar									oz-in (Nm)	Amps DC
					+/ -10%									
1 Stack	N41xxHF-L	•			1675 (11.8)	5.2	0.64	12.2	42 (0.30)	1.9	0.0783 (0.55)	11 (4.98)	125 (556)	11 (4.98)
	N41xxLF-L		•			2.6	2.56	48.9						
	N41xxHM-L	•			1655 (11.7)	10.7	0.16	2.8						
	N41xxLM-L		•			5.3	0.63	11.1						
	N41xxHL-L	•			1625 (11.5)	8.7	0.93	3.9						
	N41xxLL-L		•			4.4	0.58	15.8						
	N41xxHJ-L	•			1630 (11.5)	5.5	0.31	10.1						
	N41xxLJ-L		•			2.7	0.47	40.4						
	N41xxLG-L	•			1630 (11.5)	3.5	1.45	25.1						
	N41xxHG-L		•			1.73	5.76	100						
	N41xxEF-L			•	1185 (8.37)	3.7	1.28	12.2						
	N41xxEM-L			•	1170 (8.26)	7.5	0.23	2.8						
	N41xxEL-L			•	1150 (8.12)	6.2	2.33	3.9						
	N41xxEJ-L			•	1150 (8.12)	3.9	1.16	10.1						
N41xxEG-L			•	1150 (8.12)	2.4	2.89	25.1							
Enhanced 1 Stack	K41xxHF-L	•			2170 (15.3)	5.2	0.64	9.5	65 (0.46)	1.9	0.0783 (0.55)	11 (4.98)	125 (556)	11 (4.98)
	K41xxLF-L		•			2.6	2.56	38						
	K41xxHM-L	•			2135 (15.1)	10.7	0.16	2.2						
	K41xxLM-L		•			5.3	0.63	8.7						
	K41xxHL-L	•			2090 (14.8)	8.7	0.23	3.1						
	K41xxLL-L		•			4.4	0.93	12.3						
	K41xxHJ-L	•			2095 (14.8)	5.5	0.58	7.8						
	K41xxLJ-L		•			2.7	2.33	31.4						
	K41xxLG-L	•			2095 (14.8)	3.5	1.45	19.5						
	K41xxHG-L		•			1.73	5.80	77.9						
	N41xxEF-L			•	1535 (10.8)	3.7	1.28	9.5						
	K41xxEM-L			•	1510 (10.7)	7.5	0.31	2.2						
	K41xxEL-L			•	1480 (10.5)	6.2	0.47	3.1						
	K41xxEJ-L			•	1480 (10.5)	3.9	1.16	7.8						
K41xxEG-L			•	1480 (10.5)	2.4	2.89	25.1							
2 Stack	N42xxHF-L	•			2925 (20.6)	5.5	0.81	14.4	84 (0.59)	1.3	0.155 (1.09)	18.4 (8.34)	125 (556)	11 (4.98)
	N42xxLF-L		•			2.7	3.2	57.7						
	N42xxHN-L	•			3130 (22.1)	15.8	0.10	2.1						
	N42xxLN-L		•			7.9	0.41	8.4						
	N42xxHM-L	•			3145 (22.2)	9.9	0.25	5.5						
	N42xxLM-L		•			4.9	1.02	22						
	N42xxHL-L	•			3085 (21.8)	8.1	0.38	7.8						
	N42xxLL-L		•			4.0	1.51	31.2						
	N42xxHK-L	•			3105 (21.9)	6.4	0.60	12.8						
	N42xxLK-L		•			3.2	2.41	51.1						
	N42xxLG-L	•			2315 (22.7)	4.8	1.07	25.3						
	N42xxHG-L		•			2.4	4.27	101						
	N42xxEF-L			•	2065 (14.6)	3.9	1.62	14.4						
	N42xxEN-L			•	2215 (15.6)	11.2	0.21	2.1						
	N42xxEM-L			•	2225 (15.7)	7.0	0.51	5.5						
	N42xxEL-L			•	2185 (15.4)	5.7	0.75	7.8						
	N42xxEK-L			•	2200 (15.5)	4.5	1.2	12.8						
	N42xxEG-L			•	2920 (20.6)	3.4	2.14	19.4						

Note: See page 88 for K&N series connection diagrams and switching sequence.

Continued on page 83.

K4 / N4 Performance Data (continued)

Motor Model Number	Config.			Holding Torque (2 phases on) oz-in (Nm) +/-10%	Rated Current/Phase Amps DC	Phase Resistance Ohms +/-10%	Phase Inductance mH Typical	Detent Torque oz-in (Nm)	Thermal Resistance Mounted °C/Watt	Rotor Inertia oz-in-s ² (kg-m ² x 10 ⁻³)	Weight lb (kg)	Shaft Loading	
	Parallel	Series	Unipolar									Radial Force lb (N)	Axial Force lb (N)
Enhanced 2 Stack	K42xxHF-L	•	•	3700 (26.11)	5.5	0.81	11.1	126 (0.89)	1.2	0.155 (1.09)	18.4 (8.34)	125 (556)	11 (4.98)
	K42xxLF-L				2.7	3.23	44.2						
	K42xxHN-L	•		4000 (28.2)	15.8	0.10	1.6						
	K42xxLN-L		•		7.9	0.41	6.5						
	K42xxHM-L	•		4025 (28.4)	9.9	0.25	4.2						
	K42xxLM-L		•		4.9	1.02	16.9						
	K42xxHL-L	•		3935 (27.8)	8.1	0.38	6.0						
	K42xxLL-L		•		4.0	1.51	23.9						
	K42xxHK-L	•		3965 (28.0)	6.4	0.60	9.8						
	K42xxLK-L		•		3.2	2.41	39.2						
	K42xxLG-L	•		4130 (29.1)	4.8	1.07	19.4						
	K42xxHG-L		•		2.4	4.27	77.5						
	K42xxEF-L		•	2615 (18.5)	3.9	1.62	11.1						
	K42xxEN-L		•	2830 (20.0)	11.2	0.21	1.6						
	K42xxEM-L		•	2845 (20.1)	7.0	0.51	4.2						
	K42xxEL-L		•	2785 (19.7)	5.7	0.75	6.0						
K42xxEK-L		•	2805 (19.8)	4.5	1.2	9.8							
K42xxEG-L		•	2920 (20.6)	3.4	2.14	19.4							
3 Stack	N43xxHN-L	•		4365 (30.8)	15.4	0.14	3.2	106 (0.75)	1.0	0.229 (1.62)	25.7 (11.6)	125 (556)	11 (4.98)
	N43xxLN-L		•		7.7	0.55	13						
	N43xxHM-L	•		4320 (30.5)	9.9	0.33	7.7						
	N43xxLM-L		•		4.9	1.32	30.7						
	N43xxHL-L	•		4250 (30.0)	8.0	0.50	11						
	N43xxLL-L		•		4.0	1.98	44.2						
	N43xxHK-L	•		4340 (30.6)	6.2	0.82	19.6						
	N43xxLK-L		•		3.1	3.29	78.5						
	N43xxEN-L		•	3090 (21.8)	10.9	0.28	3.2						
	N43xxEM-L		•	3055 (21.6)	7.0	0.66	7.7						
	N43xxEL-L		•	3010 (21.2)	5.7	0.99	11						
	N43xxEK-L		•	3070 (21.7)	4.4	1.65	19.6						
Enhanced 3 Stack	K43xxHN-L	•		5700 (40.2)	15.4	0.14	2.5	118 (0.83)	1.0	0.229 (1.62)	25.7 (11.6)	125 (556)	11 (4.98)
	K43xxLN-L		•		7.7	0.55	10						
	K43xxHM-L	•		5630 (39.7)	9.9	0.33	5.9						
	K43xxLM-L		•		4.9	1.32	23.7						
	K43xxHL-L	•		5530 (39.0)	8.0	0.50	8.5						
	K43xxLL-L		•		4.0	1.98	34.1						
	K43xxHK-L	•		5655 (39.9)	6.2	0.82	15.2						
	K43xxLK-L		•		3.1	3.29	60.7						
	K43xxEN-L		•	4030 (28.4)	10.9	0.28	2.5						
	K43xxEM-L		•	3985 (28.1)	7.0	0.66	5.9						
	K43xxEL-L		•	3910 (27.6)	5.7	0.99	8.5						
	K43xxEK-L		•	4000 (28.2)	4.4	1.65	15.2						

Note: See page 88 for K&N series connection diagrams and switching sequence.

K / N Series Stepper Motors

K / N SERIES STEPPER MOTORS

K4/N4 Performance Curves

N41xxHJ-L w/ P70530

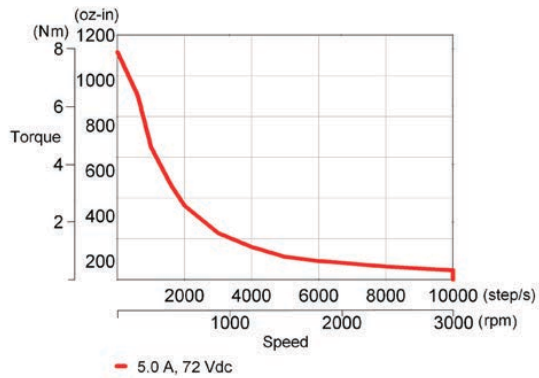

K41xxHJ-L w/ P70530

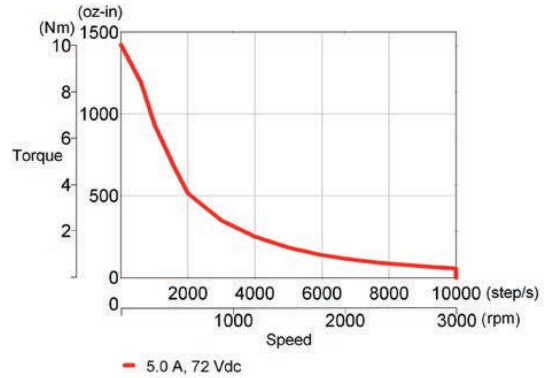

N41xxxF-L w/ P6000

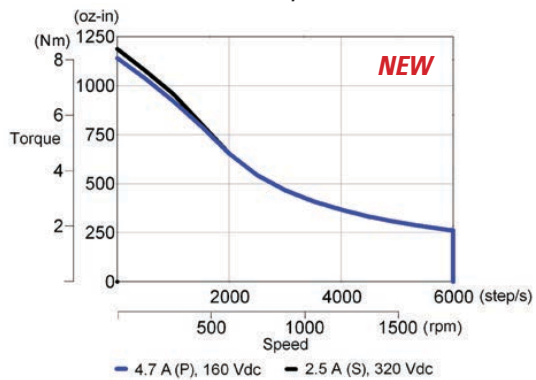

K41xxxF-L w/ P6000

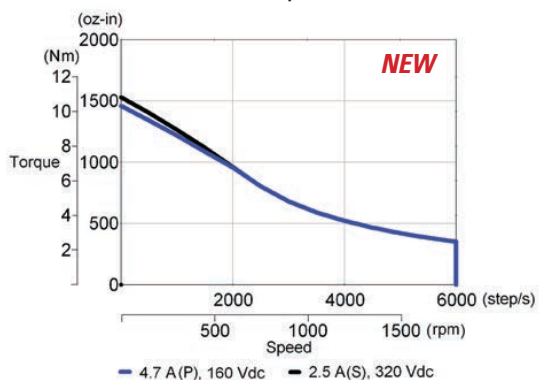

N41xxLG-L w/ P70360

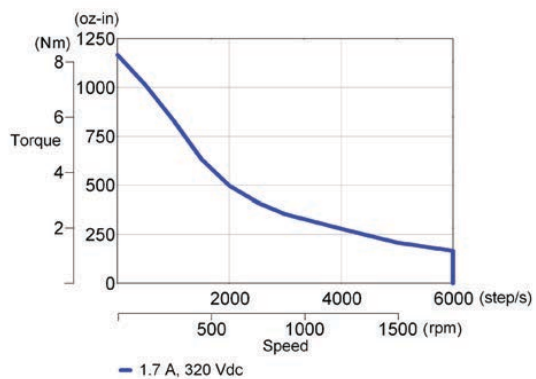

K41xxLG-L w/ P70360

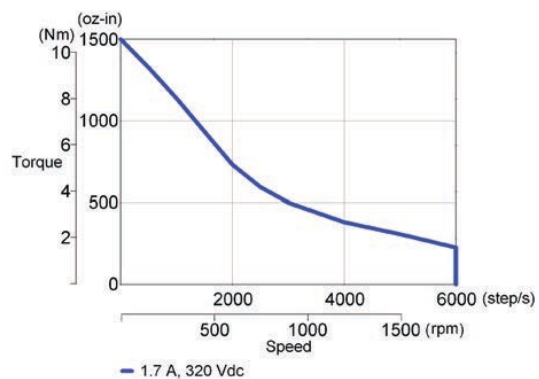

K4/N4 Performance Curves

N42xxF-L w/ P6000

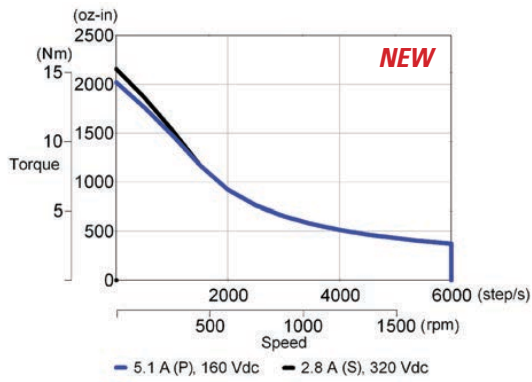

K42xxxF-L w/ P6000

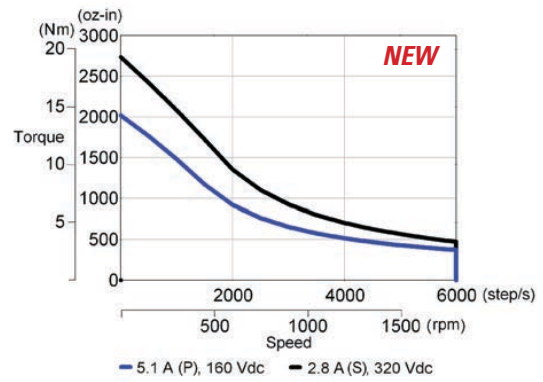

N42xxLG-L w/ P70360

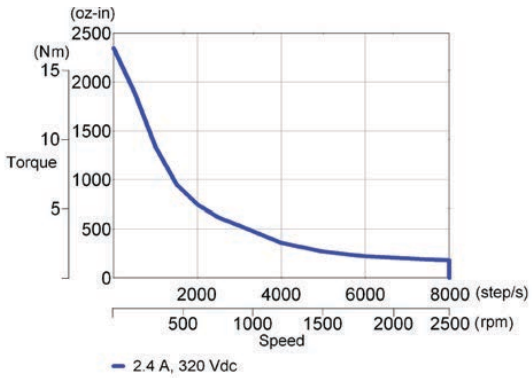

K42xxLG-L w/ P70360

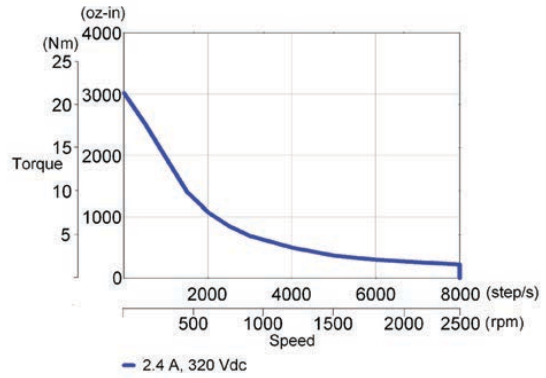

E / H Series Stepper Motors

General Specifications

- NEMA Size 23, 34, 42
- Excellent for applications requiring high torque over a wide speed range
- Standard "H" and enhanced "E" SIGMAX designs
- Special purpose low inertia "-J" option for size 23 motors provide very high torque to inertia ratios for maximum acceleration
- Unipolar or Bipolar windings
- Features: leadwire connection, straight keyway
- Other options include rear shaft and encoder mounting provisions



Parameter	E2/H2	E3/H3	E4/H4
NEMA frame size	23	34	42
Phases	2 and 4		
Full Steps per Revolution	200		
Step Angle (degrees)	1.8		
Step Accuracy % (of one full step, no load)	+/- 1.5 % E Series +/- 3.0 % H Series		
Operating Temperature	-20°C to +40°C		
Insulation Class	Class B, 130°C		
Insulation Voltage Rating	340 Vdc		
Insulation Resistance	100 Megohms		

Rotor Inertia Characteristics

Single and double stack motors are available with both standard and low inertia "-J" rotors. Choose low inertia to produce the highest acceleration rates possible. Low inertia motors are most effective for operation below 2,000 RPM. Choose standard to generate maximum torque.

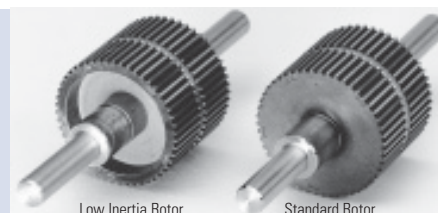

Low Inertia Rotor

Standard Rotor

E2 / H2 Outline Drawings

Leadwire Construction

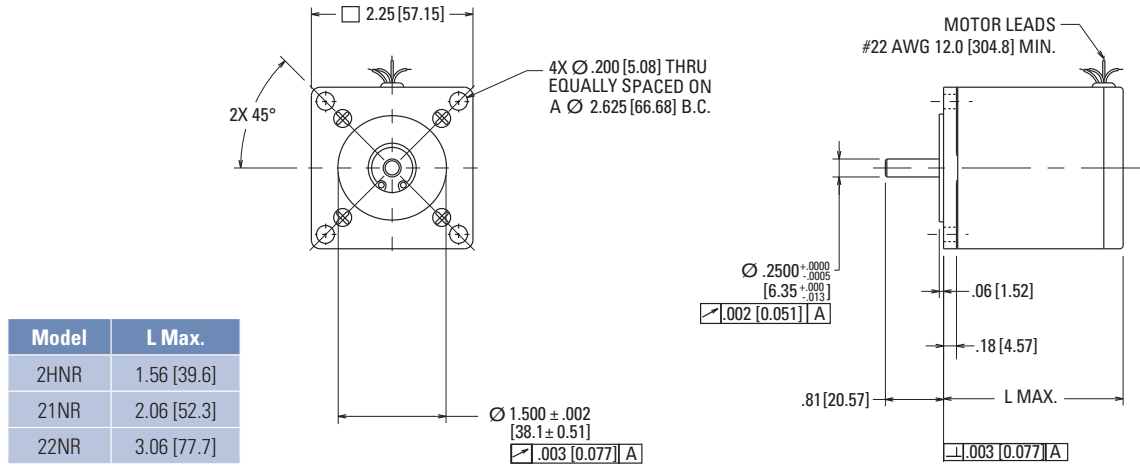

Standard Options

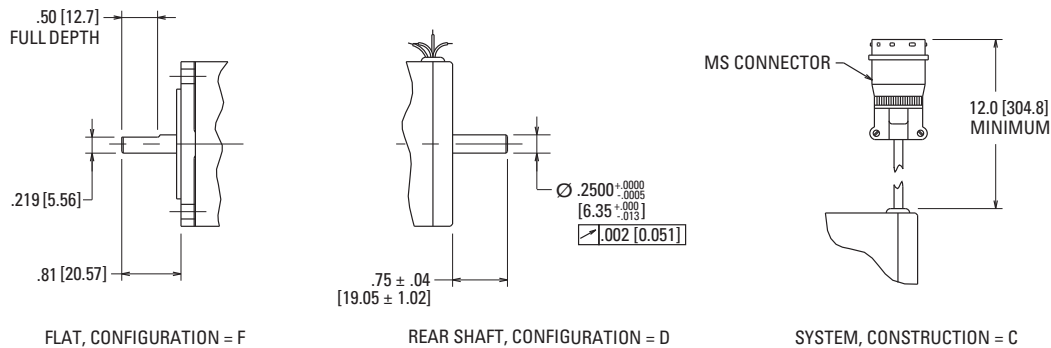

Encoder Option

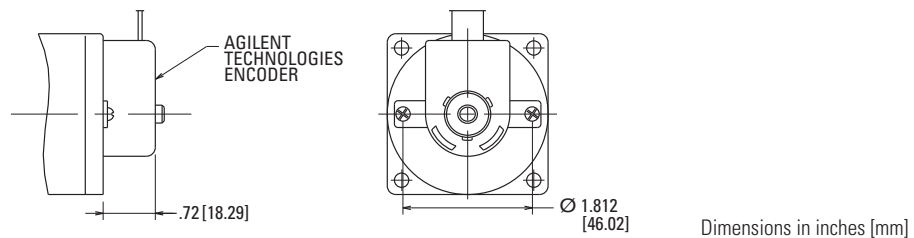

E / H Series Stepper Motors

E / H SERIES STEPPER MOTORS

E3 / H3 Outline Drawings

Leadwire Construction, Standard NEMA Front End Bell

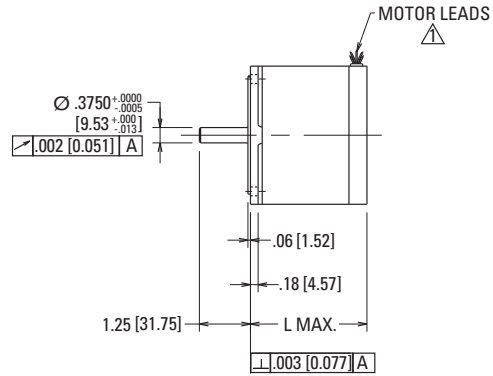
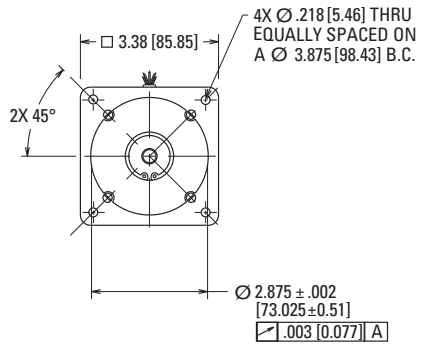

Model	L Max.
31NR	2.58 [65.5]
32NR	3.76 [95.5]
33NR	5.06 [128.5]

△ 12.0 [304.8] MINIMUM
4 Lead Motors: #18 AWG
6 & 8 Lead Motors: #22 AWG.

Dimensions in inches [mm]

Leadwire Construction, Heavy Duty Front End Bell

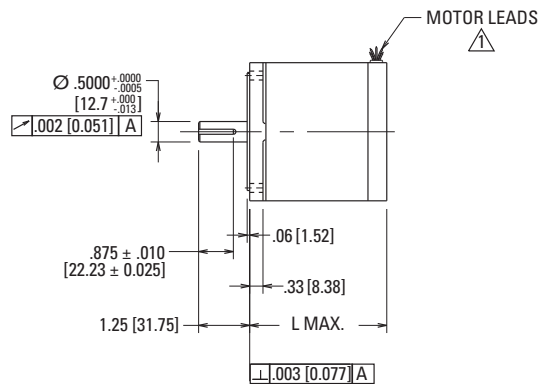
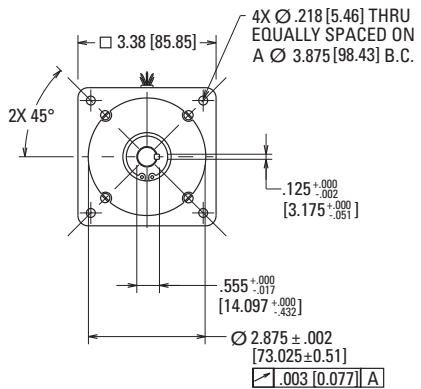

Model	Max.
33HR	5.33 [135.4]
34HR	6.58 [162.1]

△ 12.0 [304.8] MINIMUM
4 Lead Motors: #18 AWG
6 & 8 Lead Motors: #22 AWG.

Dimensions in inches [mm]

E3 / H3 Outline Drawings

Shaft Configurations

Standard Front Shaft Configurations

Note: Not available with heavy duty models

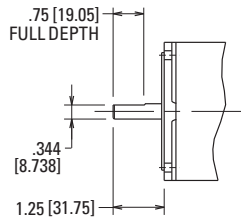

Flat, Configuration = F

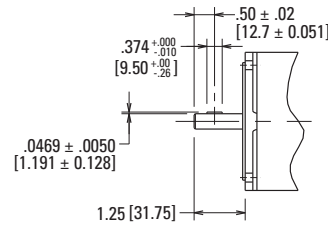

#303 Woodruff Key, Configuration = W

Standard Double Shaft Configuration

Note: Not available with splashproof models

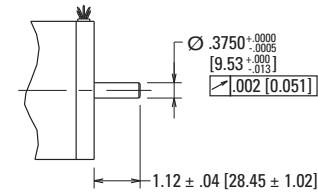

Rear Shaft, Configuration = D

Dimensions in inches [mm]

Splashdown Construction, Standard NEMA Front End Bell

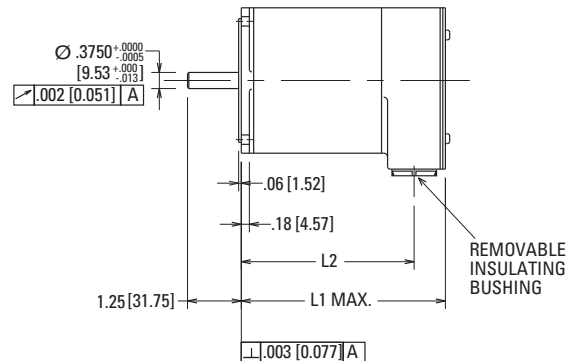
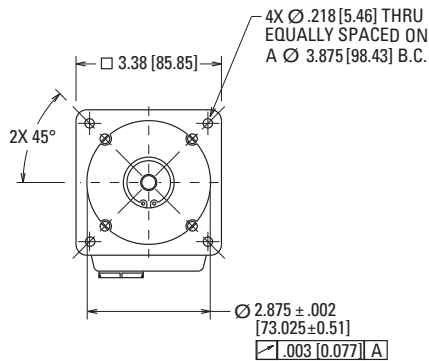

Model	L1 Max.	L2
31N[L or M]	3.62 [91.95]	2.87 [72.9]
32N[L or M]	4.77 [121.2]	4.02 [102.11]
33N[L or M]	6.05 [153.7]	5.30 [134.62]

Dimensions in inches [mm]

E / H Series Stepper Motors

E / H SERIES STEPPER MOTORS

E3 / H3 Outline Drawings

Splashdown Construction, Heavy Duty NEMA Front End Bell

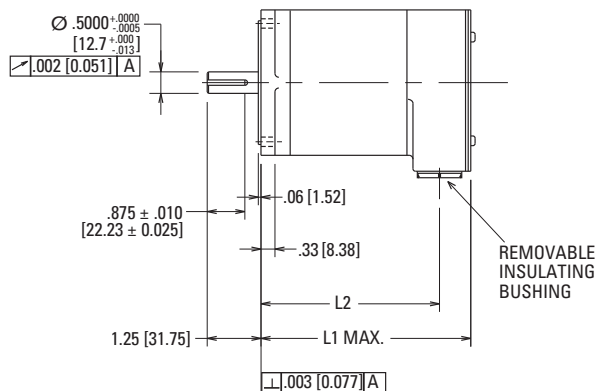
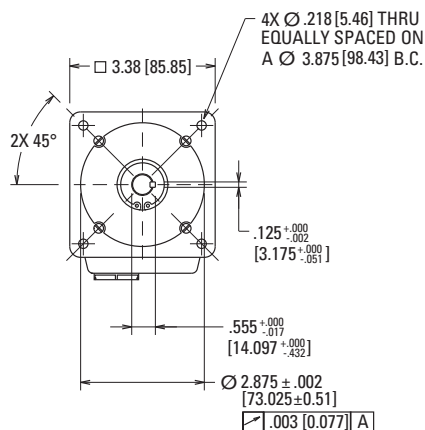

Model	L1 Max.	L2
33H[L or M]	6.73 [170.94]	5.61 [142.49]
34H[L or M]	7.62 [193.6]	6.86 [174.24]

Dimensions in inches [mm]

MS Connector, Encoder Option, Standard NEMA Front End Bell

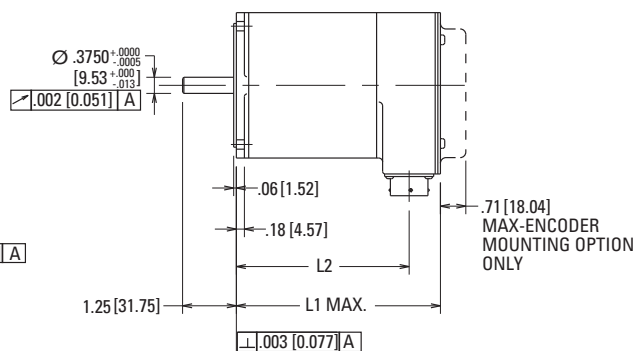
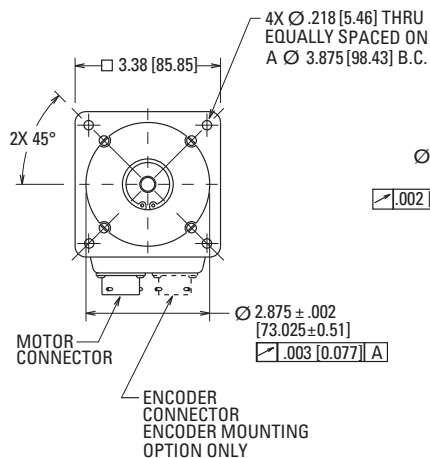

Model	L1 Max.	L2
31NC	3.62 [91.95]	2.87 [72.9]
32NC	4.77 [121.2]	4.02 [102.11]
33NC	6.05 [153.7]	5.30 [134.62]

Dimensions in inches [mm]

E3 / H3 Outline Drawings

MS Connector, Encoder Option, Heavy Duty Front End Bell

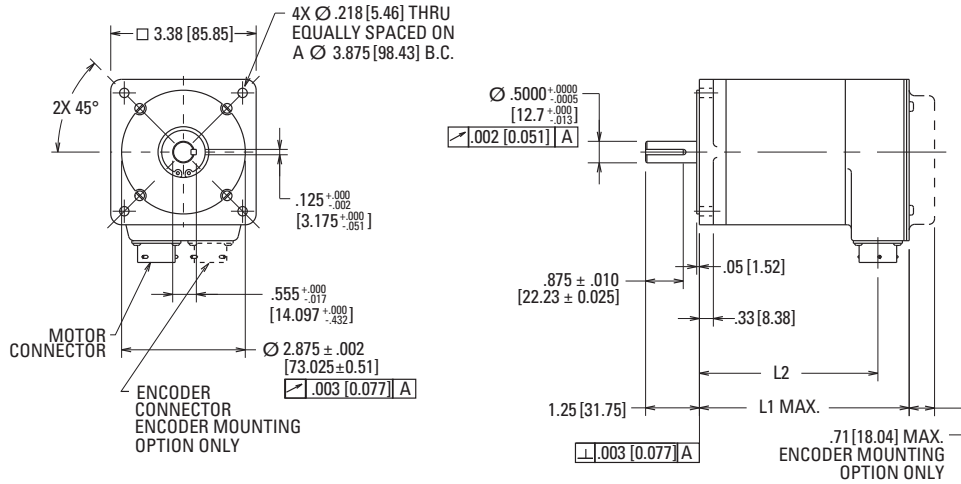

Model	L1 Max.	L2
33HC	6.73 [170.94]	5.61 [142.49]
34HC	7.62 [193.6]	6.86 [174.24]

Dimensions in inches [mm]

E4 / H4 Outline Drawings

Splashproof Construction, Terminal Board

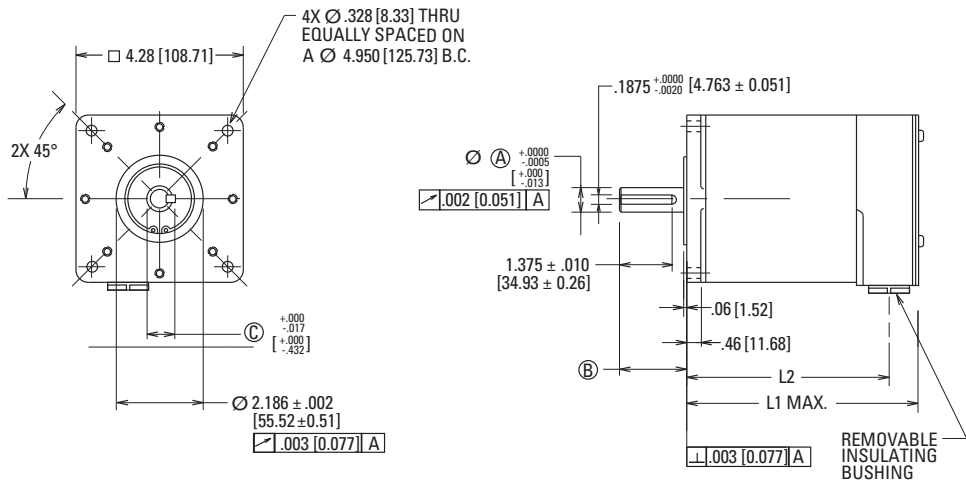

Dimensions in inches [mm]

E / H Series Stepper Motors

E / H SERIES STEPPER MOTORS

E4 / H4 Outline Drawings

MS Connector, Encoder Option

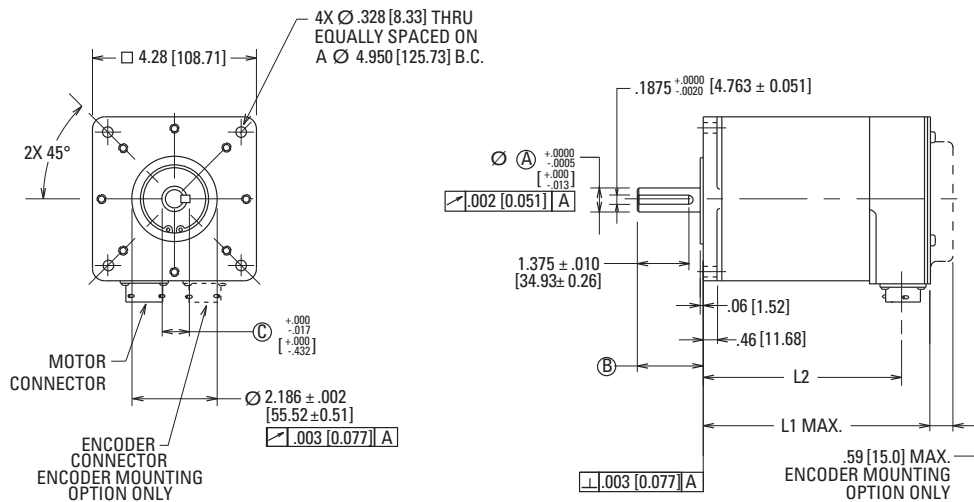

Model	L1 Max.	L2	A	B	C
41H[C.L. or M]	5.61 [142.5]	4.85 [123.19]	0.6250 [15.875]	1.75 [17.91]	0.705 [17.91]
42H[C.L. or M]	8.04 [204.22]	7.29 [185.17]	0.6250 [15.875]	2.19 [55.63]	0.705 [17.91]
43H[C.L. or M]	10.56 [268.23]	9.81 [249.18]	0.7500 [19.05]	2.19 [55.63]	0.830 [21.09]

Dimensions in inches [mm]

Standard Round Mounting Configuration

Note: Not available on 3 stack motor

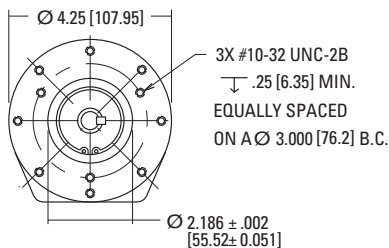

E2 / H2 Performance Data

	Motor Model Number	Config.			Holding Torque (2 phases on) oz-in (Nm) +/-10%	Rated Current/ Phase Amps DC	Phase Resistance Ohms +/-10%	Phase Inductance mH Typical	Detent Torque oz-in (Nm)	Thermal Resistance °C/Watt	Rotor Inertia oz-in-s ² (kg-m ² x 10 ⁻³)	Weight lb (kg)	Shaft Loading	
		Parallel	Series	Unipolar									Radial Force lb (N)	Axial Force lb (N)
Half Stack	H2HxxHA-L	•			51 (0.36)	4.9	0.22	0.50	1.6 (0.011)	7.1	0.0010 (0.0071)	0.90 (0.41)	19 (85)	65 (289)
	H2HxxLA-L		•			2.4	0.79	2.0						
	H2HxxHT-L	•			50 (0.35)	2.5	0.75	1.8						
	H2HxxLT-L		•			1.26	2.89	7.3						
	H2HxxHB-L	•			51 (0.36)	2.4	0.79	2.0						
	H2HxxLB-L		•			1.22	3.05	8.1						
	H2HxxEA-L			•	36 (0.25)	3.5	0.41	0.50						
	H2HxxET-L			•	36 (0.25)	1.78	1.46	1.8						
	H2HxxEB-L			•	36 (0.25)	1.73	1.54	2.0						
1 Stack	H21xxHC-L	•			83 (0.59)	5.8	0.19	0.60	2.8 (0.020)	6.0	0.0015 (0.011)	1.2 (0.54)	19 (85)	65 (289)
	H21xxLC-L		•			2.9	0.67	2.2						
	H21xxHA-L	•			87 (0.61)	5.4	0.21	0.70						
	H21xxLA-L		•			2.7	0.76	2.9						
	H21xxHT-L	•			85 (0.60)	2.8	0.72	2.5						
	H21xxLT-L		•			1.39	2.8	10.2						
	H21xxHB-L	•			84 (0.59)	1.41	2.73	9.9						
	H21xxLB-L		•			0.71	10.8	39.5						
	H21xxEC-L			•	59 (0.42)	4.1	0.35	0.60						
	H21xxEA-L			•	61 (0.43)	3.8	0.40	0.70						
	H21xxET-L			•	60 (0.42)	1.97	1.42	1.42						
	H21xxEB-L			•	60 (0.42)	1.0	5.42	9.9						
Low Inertia	H21xxHT-J	•			77 (0.54)	2.8	0.72	2.1	1.8 (0.013)	6.0	0.0012 (0.0085)	1.1 (0.50)	19 (85)	65 (289)
	H21xxLT-J		•			1.39	2.8	8.4						
	H21xxET-J			•	54 (0.38)	1.97	1.42	2.1						

Note: See page 88 for E&H series connection diagrams and switching information.

E / H Series Stepper Motors

E / H SERIES STEPPER MOTORS

E2 / H2 Performance Data

	Motor Model Number	Config.			Holding Torque (2 phases on) oz-in (Nm) +/-10%	Rated Current/ Phase Amps DC	Phase Resistance Ohms +/-10%	Phase Inductance mH Typical	Detent Torque oz-in (Nm)	Thermal Resistance Mounted °C/Watt	Rotor Inertia oz-in-s ² (kg-m ² x 10 ⁻³)	Weight lb (kg)	Shaft Loading	
		Parallel	Series	Unipolar									Radial Force lb (N)	Axial Force lb (N)
1 Stack Enhanced	E21xxHC-L	•			120 (0.85)	5.8	0.19	0.50	4.8 (0.034)	6.0	0.0015 (0.011)	1.2 (0.54)	19 (85)	65 (289)
	E21xxLC-L		•			2.9	0.67	1.9						
	E21xxHA-L	•			126 (0.89)	5.4	0.20	0.60						
	E21xxLA-L		•			2.7	0.76	2.5						
	E21xxHT-L	•			123 (0.87)	2.8	0.72	2.2						
	E21xxLT-L		•			1.39	2.8	8.7						
	E21xxHB-L	•			123 (0.87)	1.41	2.73	8.5						
	E21xxLB-L		•			0.71	10.8	33.9						
	E21xxEC-L			•	85 (0.60)	4.1	0.35	0.50						
	E21xxEA-L			•	89 (0.63)	3.8	0.40	0.60						
	E21xxET-L			•	87 (0.61)	1.97	1.42	2.2						
	E21xxEB-L			•	87 (0.61)	1.0	5.42	8.5						
Low Inertia	E21xxHT-J	•			108 (0.76)	2.8	0.72	2.2	4.5 (0.032)	6.0	0.0012 (0.0085)	1.1 (0.50)	19 (85)	65 (289)
	E21xxLT-J		•			1.4	2.8	9.0						
	E21xxET-J			•	77 (0.54)	2.0	1.42	2.2						
2 Stack	H22xxHP-L	•			146 (1.03)	6.7	0.19	0.60	4.6 (0.032)	4.4	0.0031 (0.022)	2.1 (0.95)	19 (85)	65 (289)
	H22xxLP-L		•			3.4	0.68	2.4						
	H22xxHC-L	•			151 (1.07)	6.4	0.21	0.70						
	H22xxLC-L		•			3.2	0.73	2.9						
	H22xxHT-L	•			155 (1.09)	5.0	0.33	1.3						
	H22xxLT-L		•			2.5	1.2	5.1						
	H22xxHB-L	•			156 (1.10)	3.1	0.79	3.4						
	H22xxLB-L		•			1.54	3.07	13.5						
	H22xxHD-L	•			156 (1.10)	2.4	1.25	5.5						
	H22xxLD-L		•			1.22	4.91	21.8						
	H22xxEP-L			•	103 (0.73)	4.7	0.35	0.60						
	H22xxEC-L			•	107 (0.76)	4.5	0.38	0.70						
	H22xxET-L			•	109 (0.77)	3.5	0.62	1.3						
	H22xxEB-L			•	110 (0.78)	2.2	1.55	3.4						
	H22xxED-L			•	110 (0.78)	1.72	2.47	5.5						
	Low Inertia	H22xxHT-J	•			141 (0.99)	5.0	0.33						
H22xxLT-J			•		2.5		1.2	5.0						
H22xxET-J				•	99 (0.70)	3.5	0.62	1.3						

Note: See page 88 for E&H series connection diagrams and switching information.

E2 / H2 Performance Data (continued)

Motor Model Number	Config.			Holding Torque (2 phases on) oz-in (Nm) +/-10%	Rated Current/ Phase Amps DC	Phase Resistance Ohms +/-10%	Phase Inductance mH Typical	Detent Torque oz-in (Nm)	Thermal Resistance °C/Watt Mounted	Rotor Inertia oz-in-s ² (kg-m ² x 10 ⁻³)	Weight lb (kg)	Shaft Loading	
	Parallel	Series	Unipolar									Radial Force lb (N)	Axial Force lb (N)
2 Stack Enhanced	E22xxHP-L	•		210 (1.48)	6.7	0.19	0.50	9.6 (0.068)	4.4	0.0031 (0.022)	2.1 (0.95)	19 (85)	65 (289)
	E22xxLP-L		•		3.4	0.68	2.1						
	E22xxHC-L	•		218 (1.54)	6.4	0.21	0.60						
	E22xxLC-L		•		3.2	0.73	2.5						
	E22xxHT-L	•		223 (1.57)	5.0	0.33	1.1						
	E22xxLT-L		•		2.5	1.2	4.5						
	E22xxHB-L	•		225 (1.59)	3.1	0.79	2.9						
	E22xxLB-L		•		1.6	3.07	11.8						
	E22xxHD-L	•		225 (1.59)	2.4	1.25	4.7						
	E22xxLD-L		•		1.22	4.91	19						
	E22xxEP-L		•	148 (1.05)	4.7	0.35	0.50						
	E22xxEC-L		•	154 (1.09)	4.5	0.38	0.60						
	E22xxET-L		•	158 (1.12)	3.5	0.62	1.1						
	E22xxEB-L		•	159 (1.12)	2.2	1.55	2.9						
	E22xxED-L		•	159 (1.12)	1.72	2.47	4.7						
Low Inertia	E22xxHT-J	•		196 (1.38)	5.0	0.33	1.2	9.2 (0.065)	4.4	0.0023 (0.016)	2.0 (0.91)	19 (85)	65 (289)
	E22xxLT-J		•		2.5	1.2	4.6						
	E22xxET-J		•	139 (0.98)	3.5	0.62	1.2						

Note: See page 88 for E&H series connection diagrams and switching information.

E / H Series Stepper Motors

E / H SERIES STEPPER MOTORS

E3 / H3 Performance Data

	Motor Model Number	Config.			Holding Torque (2 phases on) oz-in (Nm) +/-10%	Rated Current/ Phase Amps DC	Phase Resistance Ohms +/-10%	Phase Inductance mH Typical	Detent Torque oz-in (Nm)	Thermal Resistance Mounted °C/Watt	Rotor Inertia oz-in-s ² (kg-m ² x 10 ⁻³)	Weight lb (kg)	Shaft Loading	
		Parallel	Series	Unipolar									Radial Force lb (N)	Axial Force lb (N)
1 Stack	H31xxHP-L	•			239 (1.69)	8.4	0.13	1.0	8.8 (0.062)	3.9	0.0083 (0.0586)	3.2 (1.45)	35 (156)	180 (801)
	H31xxLP-L		•			4.2	0.52	4.0						
	H31xxHA-L	•			242 (1.71)	8.2	0.14	1.1						
	H31xxLA-L		•			4.1	0.50	4.5						
	H31xxHB-L	•			224 (1.58)	5.9	0.24	1.6						
	H31xxLB-L		•			3.0	0.94	6.4						
	H31xxHT-L	•			236 (1.67)	5.4	0.29	2.3						
	H31xxLT-L		•			2.7	1.12	9.3						
	H31xxHC-L	•			224 (1.58)	3.0	0.94	6.4						
	H31xxLC-L		•			1.48	3.73	25.8						
	H31xxEP-L			•	169 (1.19)	5.9	0.27	1.0						
	H31xxEA-L			•	171 (1.21)	5.8	0.28	1.1						
	H31xxEB-L			•	158 (1.12)	4.2	0.50	1.6						
	H31xxET-L			•	167 (1.18)	3.8	0.59	2.3						
H31xxEC-L			•	158 (1.12)	2.1	1.89	6.4							
1 Stack Enhanced	E31xxHP-L	•			344 (2.43)	8.4	0.13	1.1	22 (0.16)	3.9	0.0083 (0.0586)	3.2 (1.45)	35 (156)	180 (801)
	E31xxLP-L		•			4.2	0.52	4.4						
	E31xxHA-L	•			349 (2.46)	8.2	0.14	1.2						
	E31xxLA-L		•			4.1	0.55	4.9						
	E31xxHB-L	•			316 (2.23)	5.9	0.24	1.7						
	E31xxLB-L		•			3.0	0.94	6.9						
	E31xxHT-L	•			337 (2.38)	5.4	0.29	2.5						
	E31xxLT-L		•			2.7	1.12	10						
	E31xxHC-L	•			316 (2.23)	3.0	0.94	6.9						
	E31xxLC-L		•			1.48	3.73	27.6						
	E31xxEP-L			•	243 (1.72)	5.9	0.27	1.1						
	E31xxEA-L			•	247 (1.74)	5.8	0.28	1.2						
	E31xxEB-L			•	224 (1.58)	4.2	0.5	1.7						
	E31xxET-L			•	238 (1.68)	3.8	0.59	2.5						
	E31xxEC-L			•	223 (1.57)	2.1	1.89	6.9						

Note: See page 88 for E&H series connection diagrams and switching information.

E3 / H3 Performance Data (continued)

	Motor Model Number	Config.			Holding Torque (2 phases on) oz-in (Nm) +/-10%	Rated Current/ Phase Amps DC	Phase Resistance Ohms +/-10%	Phase Inductance mH Typical	Detent Torque oz-in (Nm)	Thermal Resistance °C/Watt	Rotor Inertia oz-in-s ² (kg-m ² x 10 ⁻³)	Weight lb (kg)	Shaft Loading	
		Parallel	Series	Unipolar									Radial Force lb (N)	Axial Force lb (N)
2 Stack	H32xxHP-L	•			471 (3.33)	8.1	0.19	2.4	18 (0.13)	2.7	0.017 (0.120)	5.3 (2.40)	35 (156)	180 (801)
	H32xxLP-L		•			4.1	0.74	9.6						
	H32xxHA-L	•			445 (3.14)	5.6	0.39	4.1						
	H32xxHA-L		•			5.6	0.39	4.1						
	H32xxHT-L	•			463 (3.27)	5.2	0.44	5.4						
	H32xxLT-L		•			2.6	1.74	21.6						
	H32xxEP-L			•	333 (2.35)	5.7	0.39	2.4						
	H32xxEA-L			•	314 (2.22)	4.0	0.78	4.1						
	H32xxET-L			•	328 (2.32)	3.7	0.89	5.4						
2 Stack Enhanced	E32xxHP-L	•			673 (4.75)	8.1	0.19	2.2	42 (0.30)	2.7	0.0170 (0.120)	5.3 (2.40)	35 (156)	180 (801)
	E32xxLP-L		•			4.1	0.74	8.9						
	E32xxHA-L	•			627 (4.43)	5.6	0.39	3.7						
	E32xxLA-L		•			2.8	1.51	15						
	E32xxHT-L	•			659 (4.65)	5.2	0.44	5.0						
	E32xxLT-L		•			2.6	1.74	19.9						
	E32xxEP-L			•	476 (3.36)	5.7	0.39	2.2						
	E32xxEA-L			•	443 (3.13)	4.0	0.78	3.7						
	E32xxET-L			•	466 (3.29)	3.7	0.89	5.0						

Note: See page 88 for E&H series connection diagrams and switching information.

E / H Series Stepper Motors

E / H SERIES STEPPER MOTORS

E3 / H3 Performance Data

Motor Model Number	Config.			Holding Torque (2 phases on) oz-in (Nm) +/-10%	Rated Current/ Phase Amps DC	Phase Resistance Ohms +/-10%	Phase Inductance mH Typical	Detent Torque oz-in (Nm)	Thermal Resistance Mounted °C/Watt	Rotor Inertia oz-in-s ² (kg-m ² x 10 ⁻³)	Weight lb (kg)	Shaft Loading	
	Parallel	Series	Unipolar									Radial Force lb (N)	Axial Force lb (N)
3 Stack	H33xxHC-L	•		659 (4.65)	11.1	0.15	1.6	27 (0.19)	2.0	0.025 (0.177)	7.6 (3.45)	35 (156)	180 (801)
	H33xxLC-L		•		5.5	0.59	6.3						
	H33xxHA-L	•		666 (4.70)	8.6	0.23	2.7						
	H33xxLA-L		•		4.3	0.87	10.8						
	H33xxHB-L	•		666 (4.70)	5.4	0.55	6.8						
	H33xxLB-L		•		2.7	2.17	27.2						
	H33xxHT-L	•		687 (4.85)	5.1	0.61	8.4						
	H33xxLT-L		•		2.6	2.41	33.6						
	H33xxHP-L	•		698 (4.93)	7.9	0.26	3.7						
	H33xxLP-L		•		4.0	1.02	14.9						
	H33xxEC-L		•	466 (3.29)	7.8	0.29	1.6						
	H33xxEA-L		•	471 (3.33)	6.1	0.46	2.7						
	H33xxEB-L		•	471 (3.33)	3.8	1.11	6.8						
	H33xxET-L		•	486 (3.43)	3.6	1.23	8.4						
H33xxEP-L		•	494 (3.49)	5.6	0.54	3.7							
3 Stack Enhanced	E33xxHC-L	•		927 (6.55)	11.1	0.15	1.3	64 (0.45)	2.0	0.025 (0.177)	7.6 (3.45)	35 (156)	180 (801)
	E33xxLC-L		•		5.5	0.59	5.3						
	E33xxHA-L	•		940 (6.64)	8.6	0.23	2.3						
	E33xxLA-L		•		4.3	0.87	9.1						
	E33xxHP-L	•		995 (7.03)	7.9	0.26	3.1						
	E33xxLP-L		•		4.0	1.02	12.6						
	E33xxHB-L	•		939 (6.63)	5.4	0.55	5.7						
	E33xxLB-L		•		2.7	2.17	22.9						
	E33xxHT-L	•		975 (6.89)	5.1	0.61	7.1						
	E33xxLT-L		•		2.6	2.41	28.2						
	E33xxEC-L		•	656 (4.63)	7.8	0.29	1.3						
	E33xxEA-L		•	664 (4.69)	6.1	0.46	2.3						
	E33xxEP-L		•	703 (4.96)	5.6	0.54	3.1						
	E33xxEB-L		•	664 (4.69)	3.8	1.11	5.7						
	E33xxET-L		•	689 (4.87)	3.6	1.23	7.1						

Note: See page 88 for E&H series connection diagrams and switching information.

E3 / H3 Performance Data (continued)

Motor Model Number	Config.			Holding Torque (2 phases on) oz-in (Nm) +/-10%	Rated Current/ Phase Amps DC	Phase Resistance Ohms +/- 10%	Phase Inductance mH Typical	Detent Torque oz-in (Nm)	Thermal Resistance Mounted °C/Watt	Rotor Inertia oz-in-s ² (kg-m ² x 10 ⁻³)	Weight lb (kg)	Shaft Loading	
	Parallel	Series	Unipolar									Radial Force lb (N)	Axial Force lb (N)
4 Stack	H34xxHA-L	•		888 (6.27)	8.1	0.29	3.8	35 (0.25)	1.7	0.035 (0.247)	9.7 (4.40)	35 (156)	180 (801)
	H34xxLA-L		•		4.1	1.14	15.1						
	H34xxHP-L	•		916 (6.47)	7.7	0.33	4.7						
	H34xxLP-L		•		3.9	1.27	18.6						
	H34xxHT-L	•		882 (6.23)	5.2	0.71	9.1						
	H34xxLT-L		•		2.6	2.8	36.5						
	H34xxEA-L		•	628 (4.43)	5.7	0.60	3.8						
	H34xxEP-L		•	648 (4.58)	5.5	0.66	4.7						
	H34xxET-L		•	624 (4.41)	3.7	1.43	9.1						
4 Stack Enhanced	E34xxHA-L	•		1250 (8.83)	8.1	0.29	3.6	83 (0.59)	1.7	0.035 (0.247)	9.7 (4.40)	96 (427)	180 (801)
	E34xxLA-L		•		4.1	1.14	13.7						
	E34xxHP-L	•		1300 (9.18)	7.7	0.33	4.4						
	E34xxLP-L		•		3.9	1.27	17.8						
	E34xxHT-L	•		1240 (8.76)	5.2	0.71	8.7						
	E34xxLT-L		•		2.6	2.8	34.8						
	E34xxEA-L		•	886 (6.26)	5.7	0.60	3.6						
	E34xxEP-L		•	920 (6.50)	5.5	0.66	4.4						
	E34xxET-L		•	879 (6.21)	3.7	1.43	8.7						

Note: See page 88 for E&H series connection diagrams and switching information.

E / H Series Stepper Motors

E / H SERIES STEPPER MOTORS

E4 / H4 Performance Data

	Motor Model No.	Config.			Holding Torque (2 phases on)	Rated Current/ Phase	Phase Resistance	Phase Inductance	Detent Torque	Thermal Resistance	Rotor Inertia	Weight	Shaft Loading	
		Parallel	Series	Unipolar									oz-in (Nm) +/-10%	Amps DC
					lb (N)	lb (N)								
1 Stack	H41xxHA-L	•			839 (5.92)	10.6	0.16	3.1	31 (0.22)	1.8	0.080 (0.565)	10.9 (4.94)	140 (623)	400 (1780)
	H41xxLA-L		•			5.3	0.64	12.4						
	H41xxHT-L	•			828 (5.84)	5.4	0.61	11.2						
	H41xxLT-L		•			2.7	2.41	44.6						
	H41xxHB-L	•			839 (5.92)	5.3	0.64	12.4						
	H41xxLB-L		•			2.7	2.54	49.4						
	H41xxEA-L			•	593 (4.19)	7.5	0.32	3.1						
	H41xxET-L			•	585 (4.13)	3.8	1.21	11.2						
	H41xxEB-L			•	593 (4.19)	3.7	1.27	12.4						
1 Stack Enhanced	E41xxHA-L	•			1380 (9.74)	10.6	0.16	2.5	58 (0.41)	1.8	0.080 (0.565)	10.9 (4.94)	140 (623)	400 (1780)
	E41xxLA-L		•			5.3	0.64	10						
	E41xxHT-L	•			1350 (9.53)	5.4	0.61	9.0						
	E41xxLT-L		•			2.7	2.41	36.1						
	E41xxHB-L	•			1380 (9.74)	5.3	0.64	10						
	E41xxLB-L		•			2.7	2.54	40						
	E41xxEA-L			•	974 (6.88)	7.5	0.32	2.5						
	E41xxET-L			•	957 (6.76)	3.8	1.21	9.0						
	E41xxEB-L			•	974 (6.88)	3.7	1.27	10						
2 Stack	H42xxHC-L	•			1650 (11.7)	14.7	0.12	3.3	50 (0.35)	1.3	0.16 (1.13)	18.2 (8.26)	140 (623)	400 (1780)
	H42xxLC-L		•			7.4	0.47	13.3						
	H42xxHB-L	•			1600 (11.3)	9.8	0.27	6.8						
	H42xxLB-L		•			4.9	1.07	27.2						
	H42xxHT-L	•			1580 (11.2)	7.9	0.41	9.8						
	H42xxLT-L		•			4.0	1.62	39.2						
	H42xxHA-L	•			1650 (11.7)	5.9	0.74	20.8						
	H42xxLA-L		•			2.9	2.96	83.4						
	H42xxEC-L			•	1170 (8.26)	10.4	0.24	3.3						
	H42xxEB-L			•	1130 (7.98)	6.9	0.54	6.8						
	H42xxET-L			•	1120 (7.91)	5.6	0.81	9.8						
	H42xxEA-L			•	1170 (8.26)	4.1	1.48	20.8						

Note: See page 88 for E&H series connection diagrams and switching information.

E4 / H4 Performance Data (continued)

	Motor Model Number	Config.			Holding Torque (2 phases on)	Rated Current/ Phase	Phase Resistance	Phase Inductance	Detent Torque	Thermal Resistance	Rotor Inertia	Weight	Shaft Loading	
		Parallel	Series	Unipolar									oz-in (Nm) +/-10%	Amps DC
					lb (N)	lb (N)								
2 Stack Enhanced	E42xxHC-L	•			2700 (19.1)	14.7	0.12	2.7	81 (0.57)	1.3	0.16 (1.13)	18.2 (8.26)	140 (623)	400 (1780)
	E42xxLC-L		•			7.4	0.47	10.6						
	E42xxHB-L	•				9.8	0.27	5.4						
	E42xxLB-L		•		2600 (18.4)	4.9	1.07	21.7						
	E42xxHT-L	•				7.9	0.41	7.8						
	E42xxLT-L		•			4.0	1.62	31.3						
	E42xxHA-L	•			2690 (19.0)	5.9	0.74	16.6						
	E42xxLA-L		•			2.9	2.96	66.5						
	E42xxEC-L			•		1910 (13.5)	10.4	0.24						
	E42xxEB-L			•	1840 (13.0)	6.9	0.54	5.4						
	E42xxET-L			•	1810 (12.8)	5.6	0.81	7.8						
	E42xxEA-L			•	1900 (13.4)	4.1	1.48	16.6						
3 Stack	H43xxHC-L	•			2160 (15.3)	13.3	0.21	1.3	70 (0.49)	0.90	0.24 (1.69)	25.7 (11.7)	140 (623)	400 (1780)
	H43xxLC-L		•			6.7	0.84	5.4						
	H43xxHB-L	•				12.5	0.24	1.8						
	H43xxLB-L		•		2260 (16.0)	6.2	0.96	7.0						
	H43xxHT-L	•				7.9	0.60	16.8						
	H43xxLT-L		•			4.0	2.38	67.1						
	H43xxHA-L	•			2340 (16.5)	5.0	1.48	40.8						
	H43xxLA-L		•			2.5	5.9	163						
	H43xxEC-L			•		1530 (10.8)	9.4	0.42						
	H43xxEB-L			•	1600 (11.3)	8.8	0.48	1.8						
	H43xxET-L			•	1870 (13.2)	5.6	1.19	16.8						
	H43xxEA-L			•	1860 (13.1)	3.5	2.95	40.8						
3 Stack Enhanced	E43xxHC-L	•			3720 (26.3)	13.3	0.21	3.7	106 (0.75)	0.90	0.24 (1.69)	25.7 (11.7)	140 (623)	400 (1780)
	E43xxLC-L		•			6.7	0.84	14.7						
	E43xxHB-L	•				12.5	0.24	4.8						
	E43xxLB-L		•		3960 (28.0)	6.2	0.96	19.3						
	E43xxHT-L	•				7.9	0.60	11.8						
	E43xxLT-L		•			4.0	2.38	47						
	E43xxHA-L	•			3930 (27.8)	5.0	1.48	28.6						
	E43xxLA-L		•			2.5	5.9	114						
	E43xxEC-L			•		2670 (18.9)	9.4	0.42						
	E43xxEB-L			•	2800 (19.8)	8.8	0.48	4.8						
	E43xxET-L			•	2780 (19.6)	5.6	1.19	11.8						
	E43xxEA-L			•	2760 (19.5)	3.5	2.95	28.6						

Note: See page 88 for E&H series connection diagrams and switching information.

MH172 Series Stepper Motors

MH172 SERIES STEPPER MOTORS

General Specifications

- NEMA Size 66
- Conventional hybrid stepper motor
- Standard NEMA mounting
- UL, cUL compliant
- Unipolar or Bipolar windings
- Features: terminal box, keyway
- Options: rear shaft extensions, encoders
- Custom Motors

Phases	2
Full Steps per Revolution	200
Step Angle	1.8°
Step Accuracy (of one full step, no load)	± 5 %
Operating Temperature	-20°C to +40°C
Insulation Class	Class F, 155°C
Insulation Voltage Rating	340 Vdc
Insulation Resistance	100 Megohms

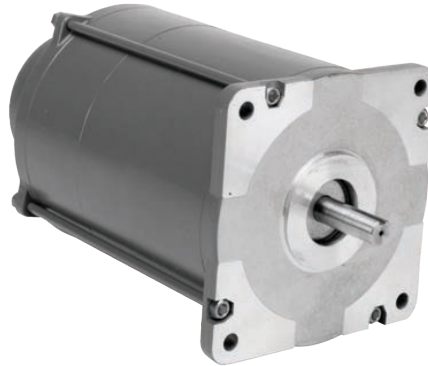

MH172 Outline Drawings

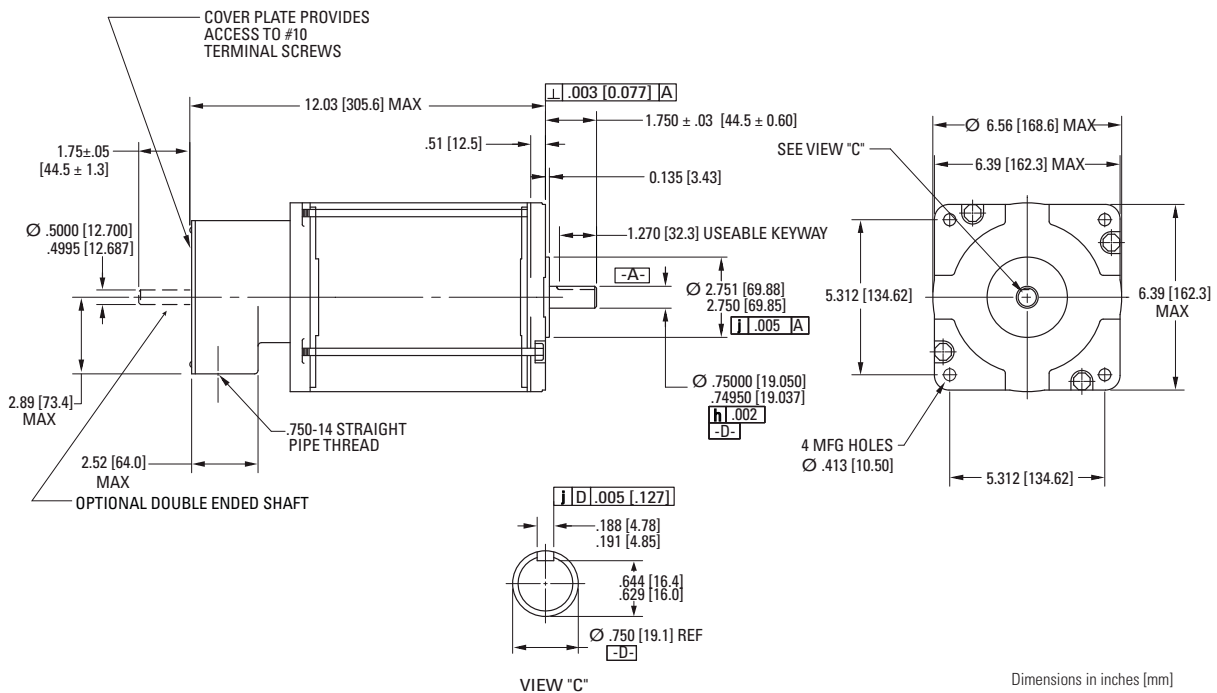

MH172 Performance Data

Motor Model Number	Config.		Holding Torque (2 phases on) oz-in (Nm) +/-10%	Rated Current/ Phase Amps DC	Phase Resistance Ohms +/-10%	Phase Inductance mH Typical	Detent Torque oz-in (Nm)	Thermal Resistance Mounted °C/Watt	Rotor Inertia oz-in-s ² (kg-m ² x 10 ⁻³)	Weight lb (kg)	Shaft Loading	
	Parallel	Series									Radial Force lb (N)	Axial Force lb (N)
	MH172	•		6120 (42.2)	21	0.077	2.1	50 (0.35)	1.1	0.87 (6.1)	53 (24)	25 (111)
MH172		•	10.6		0.31	8.5						

Note: See page 88 for MH172 series connection diagrams and switching information.

MH172 Performance Curves

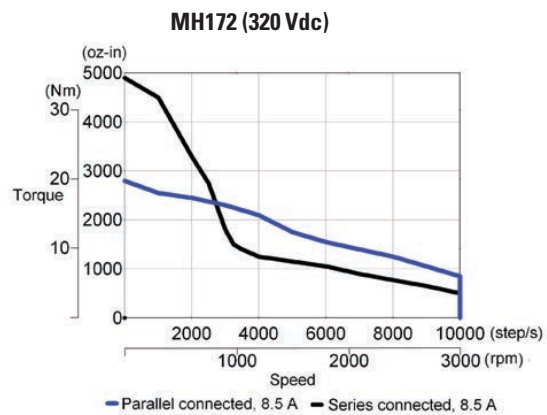
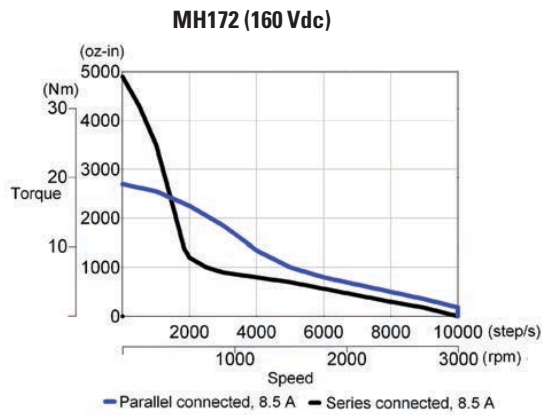

MX9 Series Stepper Motors

General Specifications

- NEMA 34 (90 mm)
- Conventional hybrid stepper motor
- Hazardous duty, UL Class 1, Division 1, Group D
- Unipolar or Bipolar windings
- Features: leadwire connection
- Options: rear shaft extension

Phases	2
Full Steps per Revolution	200
Step Angle	1.8°
Step Accuracy (of one full step, no load)	± 3 %
Operating Temperature	-20°C to +40°C
Insulation Class	Class A, 105°C
Insulation Voltage Rating	340 Vdc
Insulation Resistance	100 Megohms

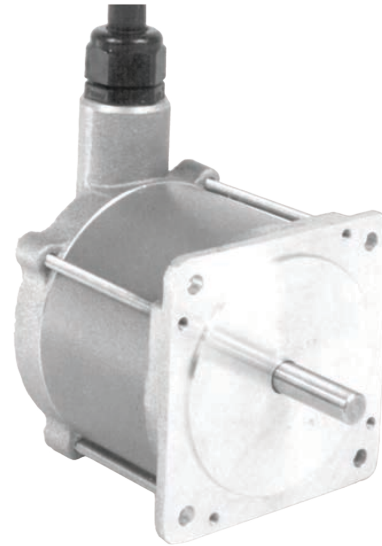

MX09 Outline Drawings

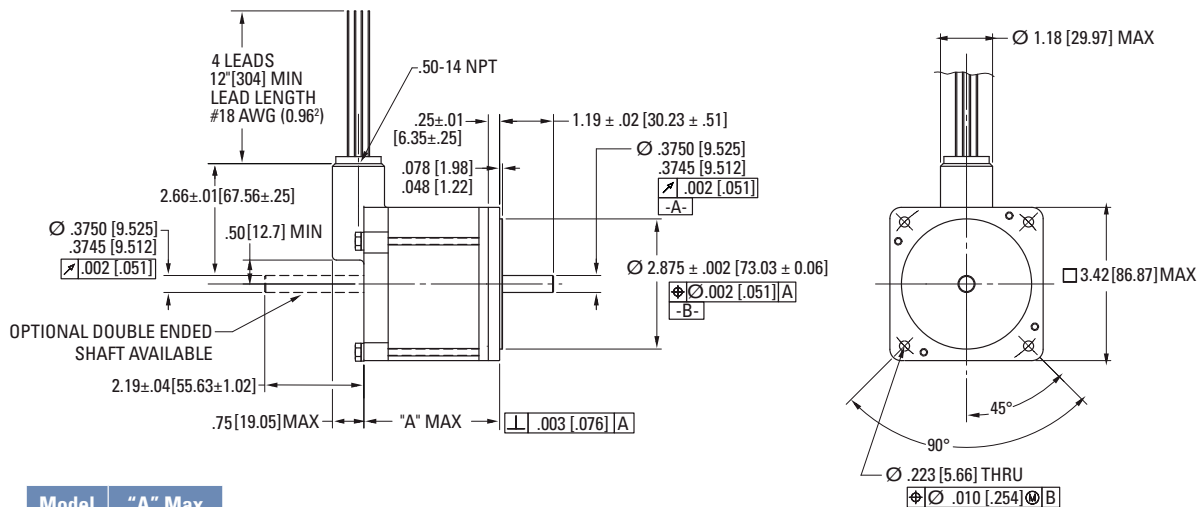

Model	"A" Max
MX91	308 (78.24)
MX92	4.33 (110.0)
MX93	5.70 (144.8)

Dimensions in inches [mm]

MX09 Performance Data

Motor Model Number	Config.			Holding Torque (2 phases on) oz-in (Nm) +/- 10%	Rated Current/Phase Amps DC	Phase Resistance Ohms +/- 10%	Phase Inductance mH Typical	Detent Torque oz-in (Nm)	Thermal Resistance Mounted °C/Watt	Rotor Inertia oz-in-s ² (kg-m ² x 10 ⁻³)	Weight lb (kg)	Shaft Loading	
	Parallel	Series	Unipolar									Radial Force lb (N)	Axial Force lb (N)
MX91-FF-206U	•			180 (1.27)	3.0	1.0	10	2.0	2.9	0.0095 (0.067)	6.0 (2.7)	25 (111)	50 (222)
MX91-FF-402U	•				4.0	0.72	6.0						
MX91-FF-403U	•				6.0	0.18	1.5						
MX92-FF-206U	•			370 (2.61)	4.0	1.0	11	4.0	1.7	0.0174 (0.123)	9.0 (4.1)	25 (111)	50 (222)
MX92-FF-401U	•				7.0	0.28	2.8						
MX93-FF-206U	•			550 (3.88)	4.0	0.90	13	7.0	2.1	0.0265 (0.187)	11 (5.0)	25 (111)	50 (222)
MX93-FF-401U	•				5.0	0.65	8.0						
MX93-FF-402U	•				7.0	0.16	2.0						

Note: See page 88 for MX series connection diagrams and switching information.

MX11 Series Stepper Motors

MX11 SERIES STEPPER MOTORS

General Specifications

- NEMA 42 (110 mm)
- Conventional hybrid step motor
- Hazardous duty, UL Class 1, Division 1, Group D
- Unipolar or Bipolar windings
- Features: leadwire connection
- Options: rear shaft extension

Phases	2
Full Steps per Revolution	200
Step Angle	1.8°
Step Accuracy (of one full step, no load)	± 5 %
Operating Temperature	-20°C to +40°C
Insulation Class	Class B, 130°C
Insulation Voltage Rating	340 Vdc
Insulation Resistance	100 Megohms

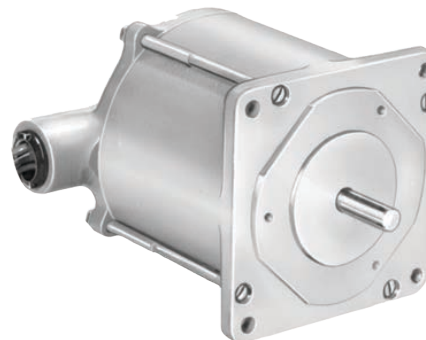

MX11 Outline Drawings

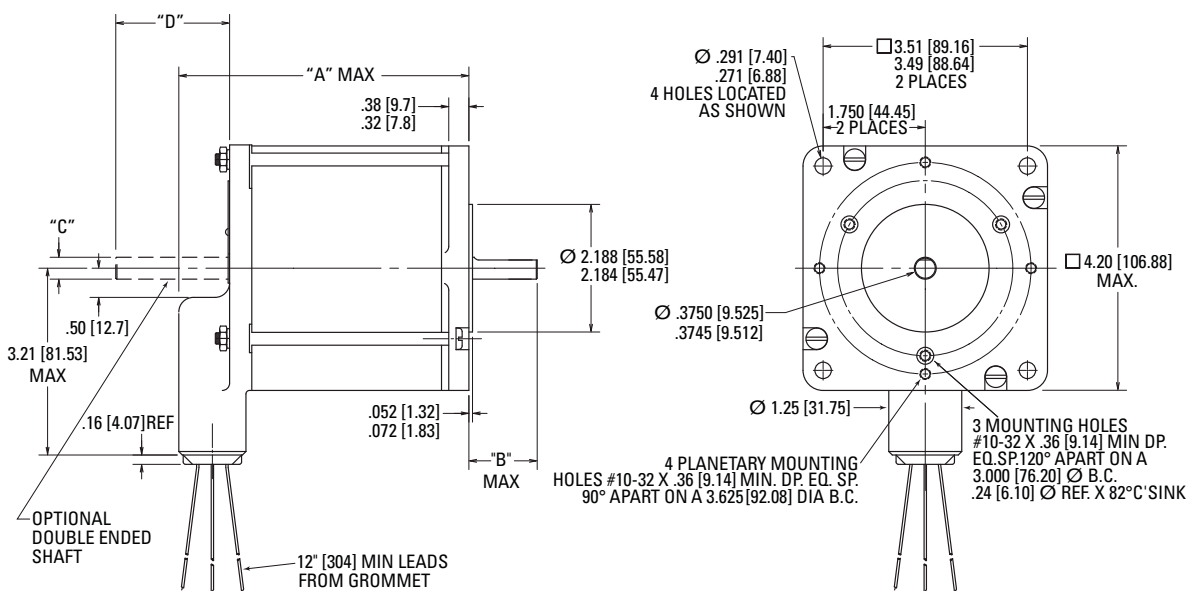

See next page for dimensions table and shaft details.

Dimensions in inches [mm]

MX11 Outline Drawings (continued)

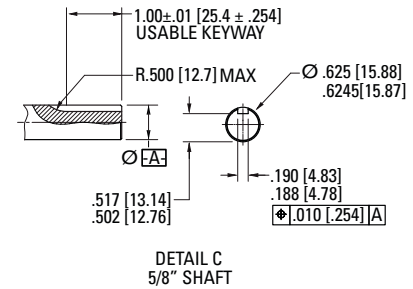
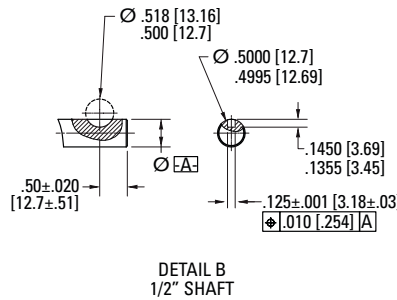
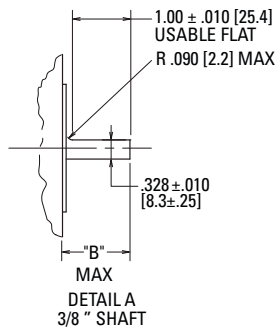

Dimensions in inches [mm]

Dimensions and Shaft Details

Model	"A" Max	"B" Max	"C"	"D"	Shaft Detail
MX111-FD/FF	5.06 (128.6)	1.25 (31.8)	Ø 0.375/0.3745 (9.525/9.512)	2.18 +/- 0.04 (55.3)	A
MX112-FD	7.45 (189.2)	1.38 (35.1)		Ø 0.5000/0.4995 (12.70/12.69)	1.25 +/- 0.04 (31.55)
MX112-FJ			C		
MX112-FF					

MX11 Performance Data

Motor Model Number	Config.			Holding Torque (2 phases on)	Rated Current/ Phase	Phase Resistance	Phase Inductance	Detent Torque	Thermal Resistance	Rotor Inertia	Weight	Shaft Loading	
	Parallel	Series	Unipolar									Radial Load	Axial Load
	oz-in (Nm) +/-10%	Amps DC	Ohms +/-10%	mH Typical	oz-in (Nm)	Mounted °C/Watt	oz-in-s ² (kg-m ² x 10 ⁻³)	lb (kg)	lb (N)	lb (N)			
MX111	•			850 (6.0)	1.1	3.6	16	6.0 (4.24)	7.4	0.55 (393)	10 (4.5)	25 (111)	50 (222)
MX112	•			1390 (9.82)	2.7	2.5	2.5	12 (8.47)	1.8	0.114 (806)	18 (8.2)	25 (111)	50 (222)

Note: See page 88 for MX series connection diagrams and switching information.

Stepper Motor Connection Information

STEPPER MOTOR CONNECTION INFORMATION

CT, K&N, E&H, T2, MH172, MX Connection Information

Available Bipolar Connection Options

4 Lead Configuration - Bipolar Connection

Motor	Flying Lead	Terminal Board	MS Connector	Connector Type	Mating Plug Type
CT	Yes	No	No	n/a	n/a
K&N	Yes	Yes	Yes	MS3102R14S-5P	MS3106F14S-5S
E&H (NEMA 23)	Yes	Yes	Yes	MS3121F14-5P	MS3116F14-5S
E&H (NEMA 34, 42)	Yes	Yes	Yes	MS3122E14-5P	MS3116F14-5S
T2	Yes	No	No	n/a	n/a
MH172	Yes	No	No	n/a	n/a
MX9, MX11	Yes	No	No	n/a	n/a

4 Lead Connection Details

Driver Connection	Lead Color (CT, K&N, E&H)	Lead Color (T2, MH172, MX9, MX11)	Terminal Number	MS Connector Pinout
A	Black	Red	1	A
\bar{A}	Orange	White/Red	3	B
B	Red	Black	2	C
\bar{B}	Yellow	White/Black	4	D
Ground	Green/Yellow	n/a	n/a	E

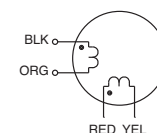

4-Lead Configuration

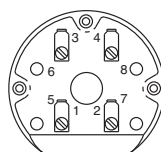

Terminal Board

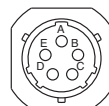

MS Connector
NEMA 23

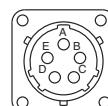

MS Connector
NEMA 34 and 42
E&H Models

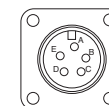

MS Connector
NEMA 34 and 42
K&N Models

CT, K&N, E&H, T2, MH172, MX Connection Information (continued)

Available Bipolar Connection Options

8 Lead Configuration - Bipolar Connection

Motor	Flying Lead	Terminal Board	MS Connector	Connector Type	Mating Plug Type
K&N	Yes	Yes	No	n/a	n/a
E&H (34, 42)	Yes	Yes	Yes	MS3122E14-12P	MS3116F14-12S
MH172	Yes	No	No	n/a	n/a
MX9, MX11	Yes	No	No	n/a	n/a

Parallel Connection Details

Driver Connection	Lead Color (CT, K&N, E&H)	Terminal Number	MS Connector Pinout
A	Blk & Wht/Org	1 & 5	A & F
\bar{A}	Org & Wht/Blk	3 & 6	B & E
B	Red & Wht/Yel	2 & 7	C & H
\bar{B}	Yel & Wht/Red	4 & 8	D & G

Series Connection Details

Driver Connection	Lead Color (CT, K&N, E&H)	Terminal Number	MS Connector Pinout
A	Black (Blk)	1	A
\bar{A}	Orange (Org)	3	B
B	Red	2	C
\bar{B}	Yellow (Yel)	4	D
None	Wht/Blk & Wht/Org	5 & 6	E & F
None	Wht/Red & Wht/Yel	7 & 8	G & H

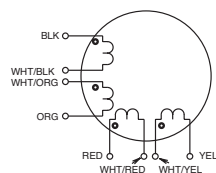

8-Lead Configuration

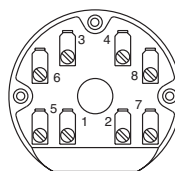

Terminal Board
NEMA 34 and 42

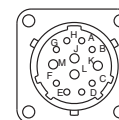

MS Connector
NEMA 34 and 42

Stepper Motor Connection Information

STEPPER MOTOR CONNECTION INFORMATION

CT, K&N, E&H, T2, MH172, MX Connection Information (continued)

Available Unipolar Connection Options

Lead Configuration – Unipolar Connection

Motor	Flying Lead	Terminal Board	MS Connector	Connector Type	Mating Plug Type
CT	Yes	n/a	n/a	n/a	n/a
K&N	Yes	Yes	No	n/a	n/a
E&H	Yes	Yes	Yes	MS3122E14-12P	MS3116F14-12S
T2	Yes	No	No	n/a	n/a
MH172	Yes	No	No	n/a	n/a
MX9, MX11	Yes	No	No	n/a	n/a

6 Lead Unipolar Connection Details

Driver Connection	Lead Color (CT, K&N, E&H)	Terminal Number	MS Connector Pinout
A	Black (Blk)	1	A
B	Orange (Org)	3	B
C	Red	2	C
D	Yellow (Yel)	4	D
+V	Wht/Blk/Org	5	J
+V	Wht/Red/Yel	6	L

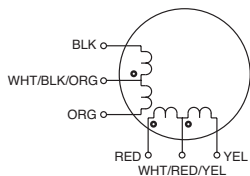

6-Lead Configuration

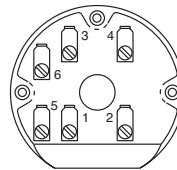

Terminal Board
NEMA 34 and 42

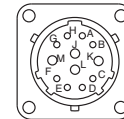

MS Connector
NEMA 34 and 42

M/P Connection Information

8 Lead Bipolar Connection Details

Series Connection Details

Driver Connection	Lead Color
A	Black (Blk)
\bar{A}	Orange (Org)
B	Red
\bar{B}	Yellow (Yel)
-	Wht/Blk/Org
-	Wht/Red/Yel

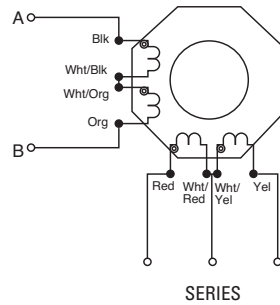

Parallel Connection

Driver Connection	Lead Color
\bar{A}	Black & Wht/Org
A	Org & Wht/Blk
\bar{B}	Red & Wht/Yel
B	Yellow & Wht/Red

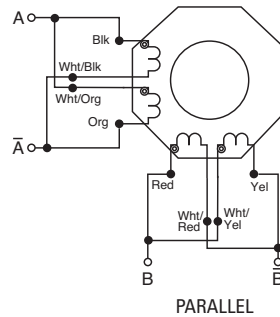

6 Lead Unipolar Connection Option

6 Lead Unipolar Connection Details

Driver Connection	Lead Color
A	Black
B	Orange
C	Red
D	Yellow
+V	Wht/Blk/Org
+V	Wht/Red/Yel

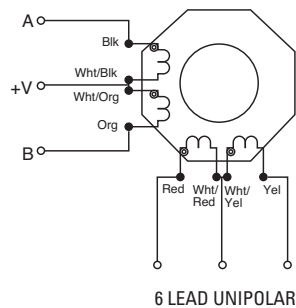

Stepper Motor Connection Information

STEPPER MOTOR CONNECTION INFORMATION

Optional Leaded Connectors

Connection Details

Part Number	Phase Connection	Pin No.	Connector/Leadwire Assembly Lead Colors	Driver Connection
GW0000F (8 Lead)	Bipolar Series	6	Black	A
		1	Orange	\bar{A}
		8	Red	B
		3	Yellow	\bar{B}
		2 & 5	Wht/Blk & Wht/Org	none
		4 & 7	Wht/Red & Wht/Yel	none
	Bipolar Parallel	6 & 5	Blk & Wht/Org	A
		1 & 2	Org & Wht/Blk	\bar{A}
		8 & 7	Red & Wht/Yel	B
		3 & 4	Yel & Wht/Red	\bar{B}
	Unipolar	6	Black	A
		1	Orange	B
		8	Red	C
		3	Yellow	D
2 & 5		Wht/Blk & Wht/Org	+V	
4 & 7		Wht/Red & Wht/Yel	+V	
GW0000E (6 Lead)	Unipolar	6	Black	A
		1	Orange	B
		8	Red	C
		3	Yellow	D
		2 & 5	Wht/Blk & Org	+V
		4 & 7	Wht/Red & Yel	+V
GW0000H (4 Lead)	Bipolar Parallel	6 & 5	Black	A
		1 & 2	Orange	\bar{A}
		8 & 7	Red	B
		3 & 4	Yellow	\bar{B}
GW0000L (4 Lead)	Bipolar Series	6	Black	A
		1	Orange	\bar{A}
		8	Red	B
		3	Yellow	\bar{B}

Four different leaded connectors are available from Kollmorgen. Order the "GW" part number as a separate item.

Typical Leaded Connector

4-lead shown

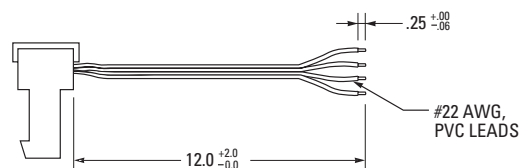



Typical Leaded Connector

A separate mating connector or housing and strain relief cover are available from Kollmorgen or AMP. The user attaches leads to the connector.

Item	Kollmorgen	AMP
Standard Housing	GP00012	641653-8
Standard Cover	GP00013	643077-8

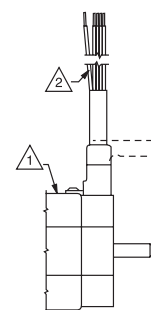
Optional Ground Wire



- NOTES:
-  GROUND LABEL PLACED IN FRONT OF GROUND SCREW.
 -  GREEN/YELLOW SAFETY EARTH CONDUCTOR (18AWG).

Phase Sequencing Tables

Driver Connections

NOTE: Direction of rotation as viewed from mounting end of motor.

LENGEND: 0 = OFF or OPEN
 + = Positive Current Flow
 - = Negative Current Flow

Bipolar Half Step Phase Sequencing

STEP	A	\bar{A}	B	\bar{B}
1	+	-	0	0
2	+	-	+	-
3	0	0	+	-
4	-	+	+	-
5	-	+	0	0
6	-	+	-	+
7	0	0	-	+
8	+	-	-	+

CCW ↓ ↑ CW

Bipolar Full Step Phase Sequencing

STEP	A	\bar{A}	B	\bar{B}
1	+	-	-	+
2	-	+	-	+
3	-	+	+	-
4	+	-	+	-
1	+	-	-	+

CCW ↓ ↑ CW

Unipolar Full Step Phase Sequencing

STEP	A	\bar{A}	B	\bar{B}
1	GND	0	GND	0
2	0	GND	GND	0
3	0	GND	0	GND
4	GND	0	0	GND
1	GND	0	GND	0

CCW ↓ ↑ CW

XTRUE™ True Planetary Gearheads



XTRUE™ TRUE PLANETARY GEARHEADS

- Cost effective precision gearheads
- The XTRUE Series is a new precision gearhead that complements our True Planetary™ Gearhead line, already the largest selection of planetary gearheads in the world.
- Move a larger load more easily and quietly with True Planetary gearing through improved load capacity, lower backlash and quieter operation.
- Experience less downtime with the flexible mounting system: RediMount™ system mounts to any motor in 3 easy steps; align, mount and tighten.
- Simplify replacement with the tapped face output which enables easy drop-in replacement.
- Go green on your machine when the assembly and all components meet EU Directive 2002/951/EC (RoHS)

Frame sizes (5):	40 mm, 60 mm, 80 mm, 120 mm, 160 mm
Precision:	13 arc-min
Torque capacity:	up to 876 Nm
Ratio availability	3:1 thru 100:1

Planetary Gearhead Technology

Helical gears are known for their quiet and smooth operation along with their ability to transmit higher loads than spur gears. Both of these features of helical gearing result from the improved contact ratio (effective teeth in mesh) over spur gears.

A high torque, whisper quiet helical gearhead has been designed by combining the positive attributes of gear crowning and helical gearing with the planetary construction to create the smoothest operating gearhead on the market.

- Broadest product range of gearheads in the industry
- Innovative gear technology offers size and performance advantages
- RediMount™ system provides error-free and reliable installations

Helical Crowned TRUE Planetary™ Gearing

Features

- High torque capacity
- Low backlash
- Smooth operation
- Greater load sharing
- Whisper quiet

Spur vs. Helical Gearing

Typical contact ratio is 1.5 for spur gearing. Contact ratio for equivalent helical gear is 3.3 – more than double the contact ratio.

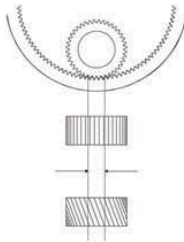

Crowned vs. Non-Crowned

Crowning optimizes the gear mesh alignment within a gear train to increase the torque capacity and reduce noise. It also enhances load distribution on the tooth flank to reduce high stress regions.

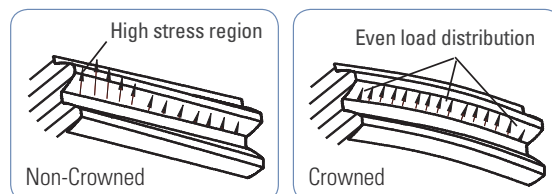

PowerTRUE™ Right Angle Gearheads

- Lower backlash from single axis mesh adjustment
- A compact design using face gear technology
- Whisper quiet operation due to high contact ratio
- Mesh ratios from 1:1 to 5:1
- Extremely efficient (98%)

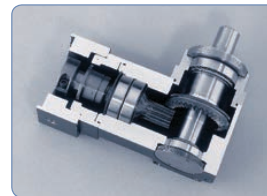

PowerTRUE™ gear technology



Computerized mapping of gear tooth profile



All Micron right angle gearheads use the PowerTRUE technology which increases the mesh ratio to 5:1 compared to a maximum of 3:1 typical in bevel gears.

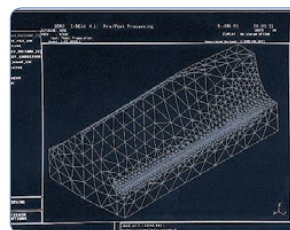

Multiple teeth in the face gear simultaneously mesh with a standard involute pinion. The continuous tooth engagement yields a high contact ratio between the gear and the pinion, increasing torque and efficiency.

XTRUE™ True Planetary Gearheads

XTRUE™ TRUE PLANETARY GEARHEADS

Outline Drawings

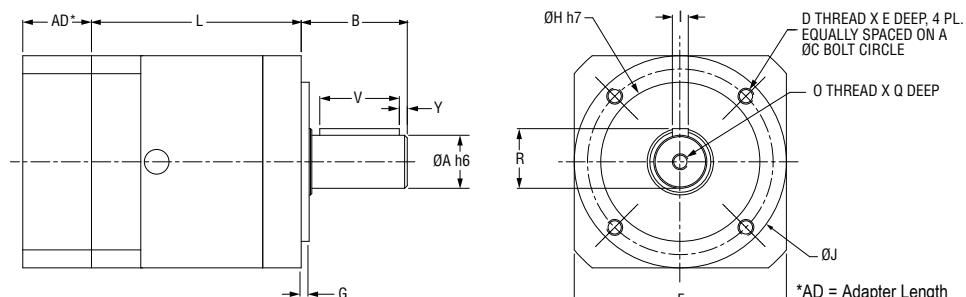

Dimensions

Part Number	D Thread	E Thread Depth mm (in)	O Output Shaft Thread	Q Thread Depth mm (in)	F Flange Square mm (in)	L Length mm (in)		C Bolt Circle mm (in)
						3:1 - 10:1	15:1 - 100:1	
XT040	M4	6 (0.24)	M3	9 (0.35)	42 (1.65)	36.5 (1.43)	49.5 (1.94)	34 (1.34)
XT060	M5	8 (0.31)	M5	12 (0.47)	61 (2.40)	51 (2.00)	68 (2.67)	52 (2.05)
XT080	M6	10 (0.39)	M6	16 (0.63)	90 (3.54)	67 (2.64)	90 (3.54)	70 (2.76)
XT120	M10	16 (0.63)	M10	22 (0.87)	119 (4.53)	87.3 (3.44)	179 (4.67)	100 (3.94)
XT160	M12	20 (0.79)	M16	36 (1.42)	142 (5.59)	119.6 (4.71)	168.9 (6.65)	145 (5.71)

Part Number	A Output Shaft Diameter mm (in)	B Output Shaft Length mm (in)	Y Shaft End Distance mm (in)	V Key Length	R Key Height mm (in)	I Key Width	H Pilot Diameter mm (in)	J Body Diameter mm (in)	G Pilot Length mm (in)
XT040	10 [0.39]	26 [1.02]	2.5 [0.10]	18 [0.71]	11.2 [0.44]	3 [0.12]	26 [1.02]	40 [1.57]	2 [0.08]
XT060	14 [0.55]	35 [1.37]	2.5 [0.10]	25 [0.98]	16 [0.63]	5 [0.20]	40 [1.57]	60 [2.36]	3 [0.12]
XT080	20 [0.79]	40 [1.57]	4.0 [0.16]	28 [1.10]	22.5 [0.89]	6 [0.24]	60 [2.36]	80 [3.15]	3 [0.12]
XT120	25 [0.98]	55 [2.16]	5.0 [0.20]	40 [1.57]	28 [1.10]	8 [0.31]	80 [3.15]	115 [4.53]	4 [0.16]
XT160	40 [1.57]	87 [3.42]	8.0 [0.32]	65 [2.55]	43 [1.69]	12 [0.47]	130 [5.12]	160 [6.30]	5 [0.20]

Specifications

Part Number	Stages	Backlash (arc-min)	Efficiency	Weight kg (lb)	Ratio Availability
XT040	1	13	93%	0.45 (1.0)	3:1, 5:1, 10:1, 15:1; 25:1, 30:1, 50:1, 100:1
	2	15	88%	0.5 (1.1)	
XT060	1	13	93%	1.0 (2.2)	3:1, 4:1, 5:1, 7:1; 10:1, 15:1, 20:1, 25:1, 30:1, 40:1, 50:1; 70:1; 100:1
	2	15	88%	1.2 (2.6)	
XT080	1	13	93%	3.0 (6.6)	3:1, 4:1, 5:1, 7:1; 8:1; 10:1, 15:1, 20:1, 25:1, 30:1, 40:1, 50:1; 70:1; 80:1; 100:1
	2	15	88%	3.7 (8.1)	
XT120	1	13	93%	5.7 (12.5)	3:1, 4:1, 5:1, 7:1; 10:1, 15:1, 20:1, 25:1, 30:1, 40:1, 50:1; 70:1; 100:1
	2	15	88%	7.3 (16.1)	
XT160	1	13	93%	12.8 (28.2)	3:1, 4:1, 5:1, 7:1; 10:1, 15:1, 20:1, 25:1, 30:1, 40:1, 50:1; 70:1; 100:1
	2	15	88%	17.2 (37.8)	

Specifications subject to change without notice.

Performance Data

	Part Number	Ratio	T ^R (20,000 Hour Life)				T _{peak} Nm (lb-in)	J kg-cm ² (lb-in-s ² ×10 ⁻⁴)	Torsional Stiffness Nm/arc-min (lb-in/arc-min)
			(1000 rpm) Nm (lb-in)	(2000 rpm) Nm (lb-in)	(3000 rpm) Nm (lb-in)	(4000 rpm) Nm (lb-in)			
XT040	XT040-003	3:1	5.2 (46)	4.2 (37)	3.7 (33)	3.4 (30)	15.6 (138)	0.013 (0.12)	0.7 (6.2)
	XT040-005	5:1	6.1 (54)	5.3 (47)	3.6 (32)	4.3 (38)	18.3 (162)	0.005 (0.04)	0.7 (6.2)
	XT040-010	10:1	5.8 (51)	4.6 (41)	4.1 (36)	3.7 (33)	17.2 (152)	0.003 (0.03)	0.7 (6.2)
	XT040-015	15:1	8.4 (74)	6.8 (60)	6.0 (53)	5.5 (49)	25.2 (223)	0.004 (0.04)	0.7 (6.2)
	XT040-025	25:1	9.3 (82)	7.6 (67)	6.7 (59)	6.1 (54)	27.8 (246)	0.004 (0.04)	0.7 (6.2)
	XT040-030	30:1	9.5 (84)	8.4 (74)	7.5 (66)	6.8 (60)	28.6 (253)	0.003 (0.03)	0.7 (6.2)
	XT040-050	50:1	11.3 (100)	9.3 (82)	8.2 (73)	7.6 (67)	33.8 (299)	0.003 (0.03)	0.7 (6.2)
	XT040-100	100:1	8.1 (72)	7.5 (66)	7.1 (63)	6.9 (61)	24.4 (216)	0.003 (0.03)	0.7 (6.2)
XT060	XT060-003	3:1	16 (139)	13 (112)	12 (102)	11 (93)	55 (483)	0.52 (4.6)	1.8 (15.9)
	XT060-004	4:1	20 (177)	17 (149)	15 (130)	14 (121)	46 (409)	0.46 (4.1)	1.8 (15.9)
	XT060-005	5:1	18 (158)	15 (130)	13 (112)	12 (102)	48 (427)	0.46 (4.1)	1.8 (15.9)
	XT060-007	7:1	17 (149)	14 (121)	12 (102)	11 (93)	43 (381)	0.46 (4.1)	1.8 (15.9)
	XT060-010	10:1	16 (139)	15 (130)	14 (121)	13 (112)	47 (418)	0.44 (3.9)	1.8 (15.9)
	XT060-015	15:1	26 (232)	21 (186)	19 (167)	17 (149)	55 (483)	0.46 (4.1)	1.8 (15.9)
	XT060-020	20:1	27 (242)	25 (223)	22 (195)	21 (186)	48 (427)	0.46 (4.1)	1.8 (15.9)
	XT060-025	25:1	25 (223)	23 (204)	20 (177)	19 (167)	55 (483)	0.46 (4.1)	1.8 (15.9)
	XT060-030	30:1	29 (260)	26 (232)	23 (204)	21 (186)	55 (483)	0.46 (4.1)	1.8 (15.9)
	XT060-040	40:1	28 (251)	27 (242)	27 (242)	25 (223)	48 (427)	0.44 (3.9)	1.8 (15.9)
	XT060-050	50:1	26 (232)	25 (223)	25 (223)	23 (204)	55 (483)	0.44 (3.9)	1.8 (15.9)
	XT060-070	70:1	25 (223)	24 (214)	24 (214)	22 (195)	48 (427)	0.44 (3.9)	1.8 (15.9)
	XT060-100	100:1	21 (186)	20 (177)	19 (167)	18 (158)	43 (381)	0.44 (3.9)	1.8 (15.9)
XT080	XT080-003	3:1	59 (520)	48 (427)	43 (381)	39 (344)	165 (1459)	2.2 (19.5)	5.4 (47.8)
	XT080-004	4:1	70 (623)	58 (511)	53 (465)	48 (427)	165 (1459)	1.8 (15.9)	5.4 (47.8)
	XT080-005	5:1	65 (576)	53 (465)	47 (418)	43 (381)	165 (1459)	1.8 (15.9)	5.4 (47.8)
	XT080-007	7:1	63 (558)	50 (446)	45 (400)	40 (353)	165 (1459)	1.7 (15.0)	5.4 (47.8)
	XT080-008	8:1	62 (549)	49 (434)	45 (398)	42 (372)	165 (1460)	1.6 (14.2)	5.4 (47.8)
	XT080-010	10:1	54 (474)	48 (427)	45 (400)	43 (381)	165 (1459)	1.8 (15.9)	5.4 (47.8)
	XT080-015	15:1	90 (799)	78 (688)	69 (613)	63 (558)	175 (1552)	1.8 (15.9)	5.4 (47.8)
	XT080-020	20:1	92 (818)	88 (781)	81 (716)	75 (660)	175 (1552)	1.5 (13.3)	5.4 (47.8)
	XT080-025	25:1	87 (771)	83 (734)	76 (669)	69 (613)	175 (1552)	1.7 (15.0)	5.4 (47.8)
	XT080-030	30:1	100 (883)	90 (799)	85 (753)	78 (688)	175 (1552)	1.7 (15.0)	5.4 (47.8)
	XT080-040	40:1	96 (846)	92 (818)	90 (799)	88 (781)	175 (1552)	1.6 (14.2)	5.4 (47.8)
	XT080-050	50:1	90 (799)	87 (771)	85 (753)	83 (734)	175 (1552)	1.6 (14.2)	5.4 (47.8)
	XT080-070	70:1	88 (781)	85 (753)	83 (734)	82 (725)	175 (1552)	1.6 (14.2)	5.4 (47.8)
XT080-080	80:1	84 (743)	80 (708)	78 (690)	74 (655)	175 (1549)	1.6 (14.2)	5.4 (47.8)	
XT080-100	100:1	72 (641)	67 (595)	63 (558)	61 (539)	175 (1552)	1.6 (14.2)	5.4 (47.8)	

T_r = Rated output torque at rated speed for specific hours of life. J = Mass moment of inertia reflected to the input shaft (including pinion assembly).
 T_{peak} = Allowable momentary peak torque for emergency stop or heavy shock loading. Specifications subject to change without notice.

XTRUE™ True Planetary Gearheads

XTRUE™ TRUE PLANETARY GEARHEADS

Performance Data (continued)

	Part Number	Ratio	T _r (20,000 Hour Life)				T _{peak} Nm (lb-in)	J kg-cm ² (lb-in-s ² x10 ⁻⁴)	Torsional Stiffness Nm/arc-min (lb-in/arc-min)
			(1000 rpm) Nm (lb-in)	(2000 rpm) Nm (lb-in)	(3000 rpm) Nm (lb-in)	(4000 rpm) Nm (lb-in)			
XT120	XT120-003	3:1	90 [799]	74 [650]	65 [576]	59 [520]	298 [2639]	4.4 [39]	17.4 [154.0]
	XT120-004	4:1	107 [948]	89 [790]	79 [697]	74 [650]	298 [2639]	3 [27]	17.4 [154.0]
	XT120-005	5:1	99 [873]	81 [716]	71 [632]	65 [576]	298 [2639]	2.9 [26]	17.4 [154.0]
	XT120-007	7:1	97 [855]	79 [697]	68 [604]	63 [558]	298 [2639]	2.8 [25]	17.4 [154.0]
	XT120-010	10:1	87 [771]	79 [697]	74 [650]	69 [613]	298 [2639]	2.5 [22]	17.4 [154.0]
	XT120-015	15:1	146 [1292]	119 [1050]	105 [929]	96 [846]	298 [2639]	2.9 [26]	17.4 [154.0]
	XT120-020	20:1	169 [1496]	139 [1227]	124 [1097]	114 [1013]	298 [2639]	2.9 [26]	17.4 [154.0]
	XT120-025	25:1	161 [1422]	130 [1152]	116 [1022]	106 [939]	298 [2639]	2.9 [26]	17.4 [154.0]
	XT120-030	30:1	180 [1589]	146 [1292]	129 [1143]	119 [1050]	298 [2639]	2.5 [22]	17.4 [154.0]
	XT120-040	40:1	187 [1654]	169 [1496]	150 [1329]	139 [1227]	298 [2639]	2.5 [22]	17.4 [154.0]
	XT120-050	50:1	179 [1580]	161 [1422]	142 [1254]	130 [1152]	298 [2639]	2.5 [22]	17.4 [154.0]
	XT120-070	70:1	176 [1561]	159 [1403]	140 [1236]	128 [1134]	298 [2639]	2.5 [22]	17.4 [154.0]
XT120-100	100:1	120 [1059]	109 [966]	104 [920]	100 [883]	298 [2639]	2.5 [22]	17.4 [154.0]	
XT160	XT160-003	3:1	317 [2806]	257 [2277]	228 [2016]	209 [1849]	876 [7750]	23 [204]	50.5 [446.9]
	XT160-004	4:1	371 [3280]	305 [2695]	272 [2407]	251 [2221]	876 [7750]	15 [133]	50.5 [446.9]
	XT160-005	5:1	350 [3094]	284 [2509]	251 [2221]	230 [2035]	876 [7750]	14 [124]	50.5 [446.9]
	XT160-007	7:1	344 [3048]	278 [2463]	246 [2174]	225 [1989]	876 [7750]	15 [133]	50.5 [446.9]
	XT160-010	10:1	222 [1961]	198 [1756]	185 [1635]	175 [1552]	876 [7750]	12 [106]	50.5 [446.9]
	XT160-015	15:1	508 [4498]	417 [3689]	370 [3271]	339 [3001]	876 [7750]	15 [133]	50.5 [446.9]
	XT160-020	20:1	513 [4544]	481 [4256]	428 [3791]	395 [3494]	876 [7750]	15 [133]	50.5 [446.9]
	XT160-025	25:1	492 [4358]	460 [4070]	407 [3605]	374 [3308]	876 [7750]	15 [133]	50.5 [446.9]
	XT160-030	30:1	562 [4971]	508 [4498]	455 [4024]	417 [3689]	876 [7750]	12 [106]	50.5 [446.9]
	XT160-040	40:1	536 [4739]	513 [4544]	500 [4423]	481 [4256]	876 [7750]	13 [115]	50.5 [446.9]
	XT160-050	50:1	515 [4553]	492 [4358]	479 [4237]	460 [4070]	876 [7750]	12 [106]	50.5 [446.9]
	XT160-070	70:1	509 [4507]	487 [4312]	474 [4191]	455 [4024]	876 [7750]	12 [106]	50.5 [446.9]
XT160-100	100:1	306 [2704]	279 [2472]	265 [2342]	254 [2249]	876 [7750]	12 [106]	50.5 [446.9]	

T_r = Rated output torque at rated speed for specific hours of life. J = Mass moment of inertia reflected to the input shaft (including pinion assembly).

T_{peak} = Allowable momentary peak torque for emergency stop or heavy shock loading. Specifications subject to change without notice.

Radial and Axial Load Ratings

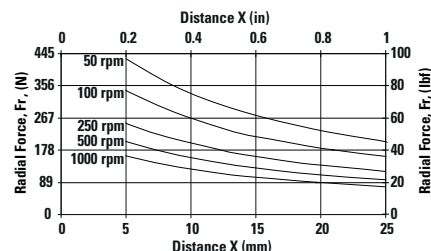
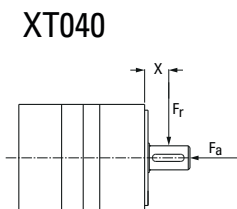

Speed (rpm)	Axial Load, F_a N (lbf)
50	737 [166]
100	585 [132]
250	431 [97]
500	342 [77]
1000	272 [61]

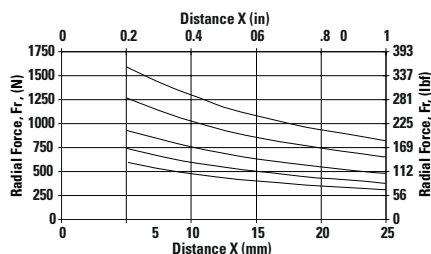
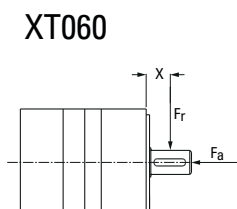

Speed (rpm)	Axial Load, F_a N (lbf)
50	2541 [571]
100	2017 [454]
250	1486 [334]
500	1180 [265]
1000	936 [211]

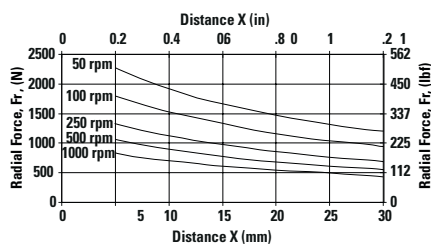
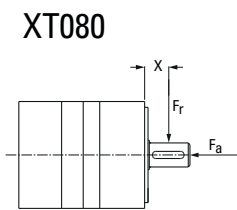

Speed (rpm)	Axial Load, F_a N (lbf)
50	3780 [850]
100	3000 [675]
250	2211 [497]
500	1755 [394]
1000	1393 [313]

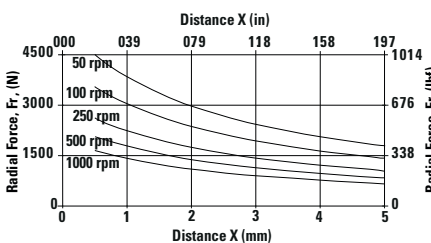
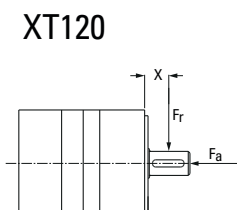

Speed (rpm)	Axial Load, F_a N (lbf)
50	6894 [1550]
100	5471 [1230]
250	4034 [907]
500	3203 [720]
1000	2540 [571]

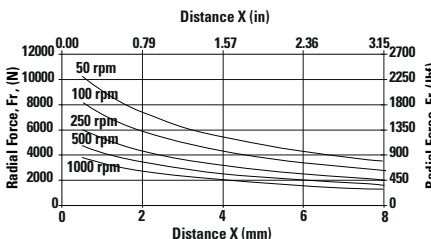
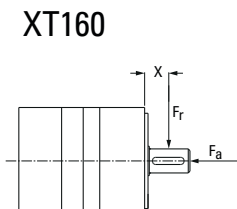

Speed (rpm)	Axial Load, F_a N (lbf)
50	14,122 [3175]
100	11,209 [2520]
250	8260 [1857]
500	6556 [1474]
1000	5204 [1170]

These graphs display the allowable radial load at a given distance (X) from the mounting surface based on an L10 life of 20,000 hours for the mean output speed.

Stepper Motor Application Worksheet

Company _____ Date _____

MOTOR

circle or specify
Note: All motors are 1.8°, 2 Phase.

- B** - Pilot Diameter
- A** - Flange Width
- E** - Max Motor Length
- F** - Pilot Depth

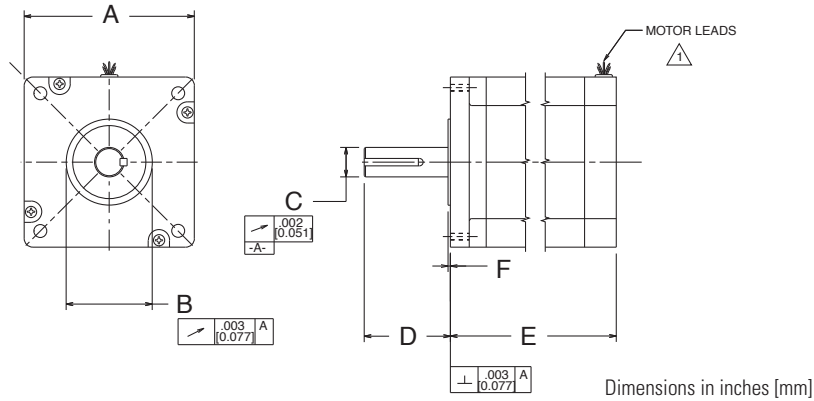

Dimensions in inches [mm]

• STANDARD AND SPECIAL FEATURES

Motor model number from catalog:

Circle whether you want standard or special features. If special, indicate details. Note that special features may result in increased price or leadtime.

• FRONT SHAFT (standard) (special)

D shaft length _____ ± _____ (±.015)*

C shaft dia. _____ ± _____ (+.0000/- .0005)*

run out Δ _____ (.002 std. ext.)*

— **Straight Key** per electric motor standards (standard option) (special)

Key: width _____ height _____

length _____ other _____

— **Flat** See Fig. 1 (standard option) (special)

Min. usable length X _____

Dim. over flat Y _____ ± _____ (±.005)*

Corner radius R allowed _____ (±.060)*

Other _____

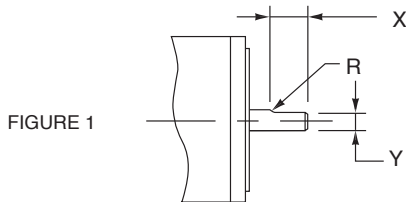

FIGURE 1

• REAR END BELL (standard) (special)

mtg. hole B.C. _____ ± _____ (±.010)*

mtg. holes _____

hole pattern _____

other _____

• REAR SHAFT (standard) (special)

shaft length _____ ± _____ (±.040)*

shaft dia. _____ ± _____ (+.0000/- .0005)*

run out Δ _____ (.002)*

other _____

— **Woodruff Key** See Fig. 2 (standard option) (special)

ANSI std. key no. _____ (Example 303)

Key location Z _____ ± _____ (±.020)*

Other _____

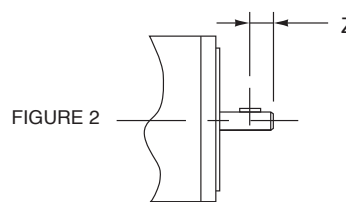

FIGURE 2

Notes:

Δ NEMA standard for shaft run out is .002" + .001" for each additional inch of extension past the standard length.

* Example of typical tolerance

Notes

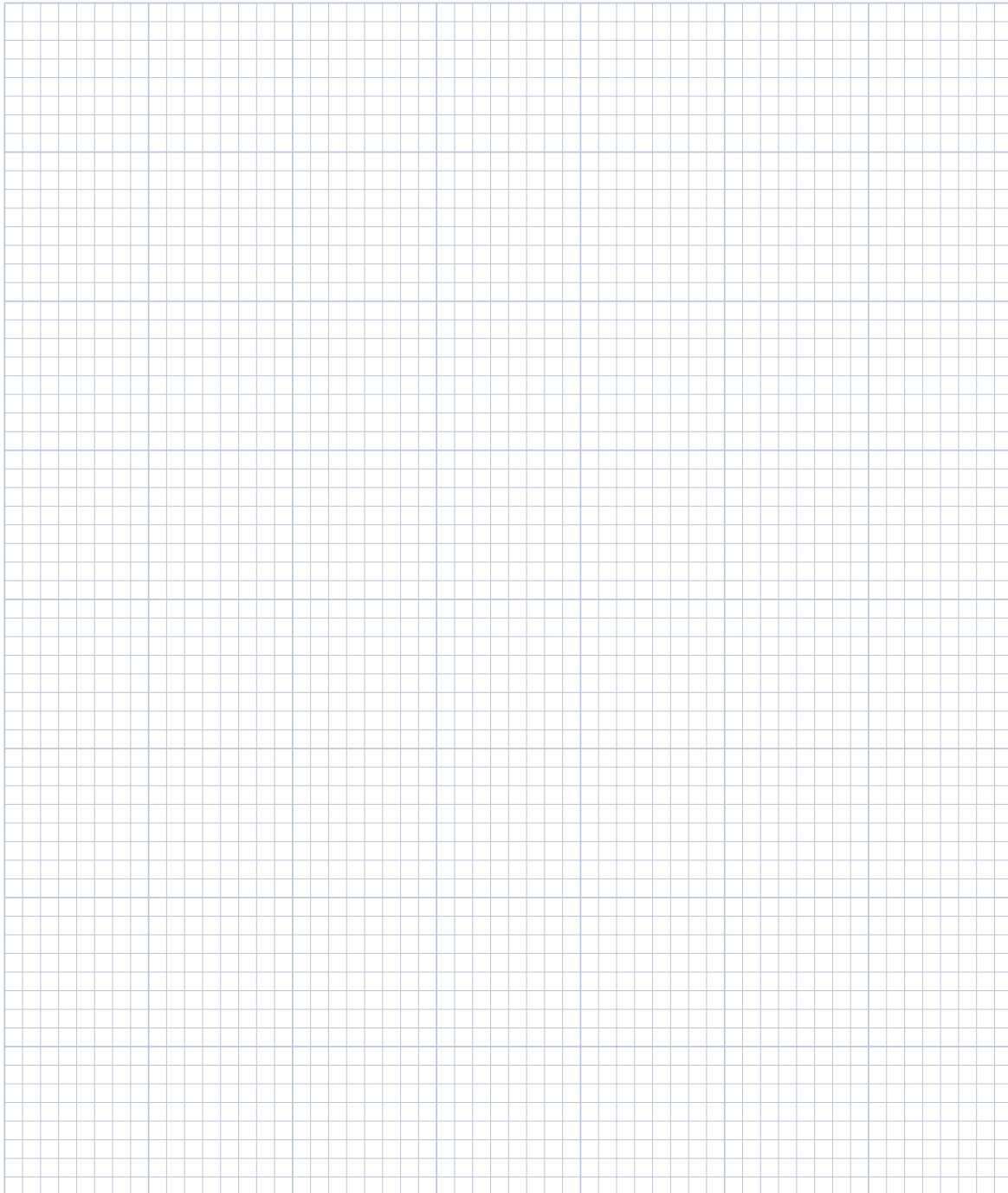

AC Synchronous Motors

Kollmorgen AC synchronous motors are high pole count motors that naturally turn at slower speeds (72 or 60 rpm). They only need a resistor – capacitor (RC) network to operate from single-phase AC utility power. For loads that operate at 72 rpm or slower, they are very cost effective and simple to use. Other motor technologies (induction, DC, servo and stepper motors) either need gear reducers, or electronic drives to match the speed of Kollmorgen synchronous motors. The cost of just the gear reduction or the cost of the electronic drive will usually exceed the total cost of the Kollmorgen synchronous motor. For even slower speeds planetary gear reducers are offered. Kollmorgen synchronous motors produce very low speeds with only modest gear reductions.

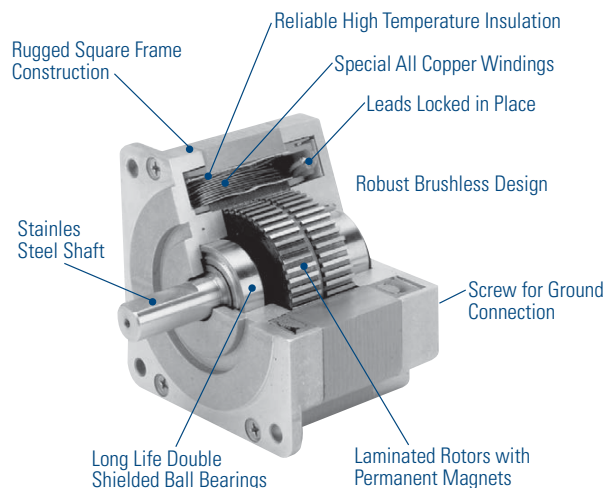
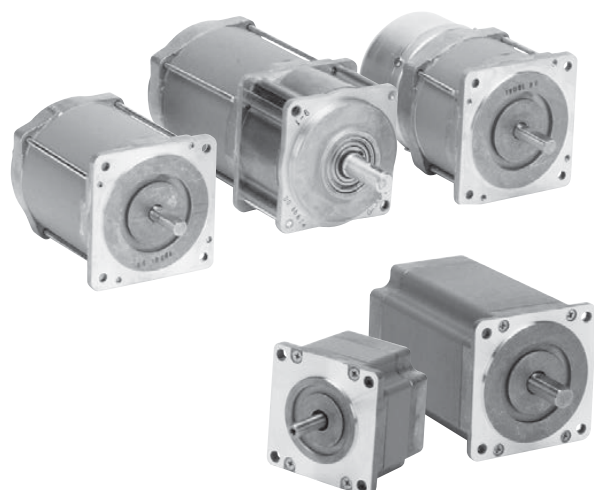

Performance Features

- 72 rpm motor speed (with 60 Hz voltage)
- 60 rpm motor speed (with 50 Hz voltage)
- Constant speed does not vary with the load
- 120 volt or 240 volt AC models
- Torques: 70 to 1,500 oz-in (0.50-10.6 Nm)
- Gear reducers with ratios up to 125:1 and torques up to 5,000 oz-in (36.7 Nm)
- UL and CE hazardous duty versions
- Fast starting, stopping, or reversing
- Can be stalled indefinitely without overheating

Typical Applications

Due to their ease of use and inherent slow speeds, Kollmorgen AC synchronous motors are used in a wide variety of applications including:

- Stirring
- Valve operation
- Metering pumps
- Cryogenic pumps
- Simple position & process controls
- Linear actuators
- Edge guides
- Variable transformers
- Dampers
- Conveyor systems
- Table lifts
- Remote control of switches, antennas, etc.

Model	NEMA	Sizes	Torque oz-in (Nm)	Family Features	Standard Options
KS06x	23	3	80 - 185 (0.56 - 1.33)	High torque construction, 120 & 240 V versions, leaded or terminal box	L, T, RS
SS24x/45x	34	2	240 - 450 (1.69 - 3.18)	1Ø & 3Ø (SS240, 450 models only) 3Ø models need only a capacitor to operate from 1Ø power High torque construction	
SS24x/45x Gearmotor	34	2	634 - 5000 (4.48 - 35.3)		
SS150/250/400/700	42	4	150 - 700 (1.06 - 4.94)		
SS1800	66	1	1800 (12.7)		
X(CE)250/700	42	2	250 - 700 (1.77 - 4.94)	Explosion proof, UL listed Class 1 Group D	L, RS
X(CE)1100/1500	66	2	1100 - 1500 (7.77 - 10.6)	Explosion proof, ATEX CE certified	

Standard Otions: L - Leaded; T - Terminal Box; RS - Rear Shaft

AC Synchronous Motors

AC SYNCHRONOUS MOTORS

AC Synchronous Motor Technology

Starting and Stopping

Rapid starting, stopping and reversing are among the advantages of Kollmorgen AC synchronous motors. The motors will start within 1-1/2 cycles of the applied frequency and will stop within 5 mechanical degrees. As shown in the typical starting curve, these motors will start and reach its full synchronous speed within 5 to 25 milliseconds. Curve A shows the motor starting in the correct direction. The motor may also momentarily start in the wrong direction, then quickly reverse and rotate in the correct direction (Curve B).

Typical Starting Characteristics for a 72 rpm Motor

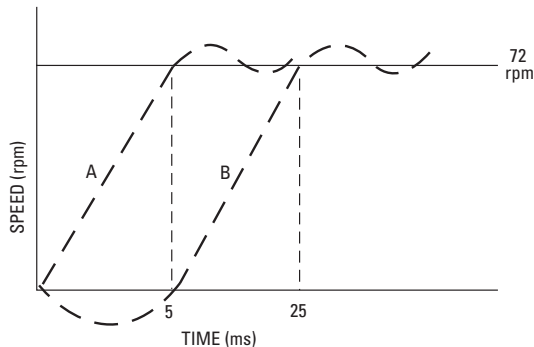

Phase-Shifting Network

The KS series and hazardous duty motors use a two-phase winding design. They are usually operated from single-phase AC power using a phase shifting network consisting of one or two resistors and a capacitor. These motors can also be operated directly from a two-phase power source.

The SS240 – SS450 series use a three phase winding design. They can be driven directly from three-phase voltage or can be operated from single-phase power using only a phase shifting capacitor. Ratings and part numbers for the phase-shifting components are shown in the motor charts. Be sure to select the correct components for the frequency of the AC power source, since the components needed for 50 hertz operation may be different from those required for operation at 60 hertz.

Temperature

All Kollmorgen AC synchronous motors are rated for continuous duty at a maximum ambient temperature of 40°C (104°F). Motor shell temperature must not be allowed to exceed 100°C (212°F) measured with a thermocouple. The minimum ambient temperature at which the motors may be operated is -40°C (-40°F), (EEx -20°C (-4°F)).

Starting and Running Current

It is not necessary to consider high starting currents when designing a control system for a Kollmorgen synchronous motor, since starting and operating current are, for all practical purposes, identical.

Stalling

If a motor becomes stalled, it will not overheat and will continue to draw only rated current. However, if the motor is stalled by running up against a stop, it will vibrate against the stop. Operating the motor continuously in this manner may eventually cause bearing failure.

Torque Versus Voltage

As indicated in the curve, the torque output of a Kollmorgen motor is approximately proportional to the applied input voltage. For intermittent operation, this characteristic can be used to provide increased torque by increasing the voltage. For example, assume that an application has a torque requirement of 200 ounce-inches (141 N-cm). Normally, a 240 ounce-inch (169 N-cm) Kollmorgen motor would be adequate, but this application is subject to wide voltage fluctuations and, therefore the 40 ounce-inch (28 N-cm) safety margin may be insufficient. The recommended practice is to use a motor having a higher torque rating. However, a larger motor may not fit in the available space. In this case, a step-up transformer could be used to increase the voltage to the 240 ounce-inch motor by approximately 10%. Because operation at a higher voltage will cause a greater temperature rise, care must be taken to assure motor shell temperature does not exceed 100°C (212°F).

Typical Torque Versus Voltage for a Synchronous Motor

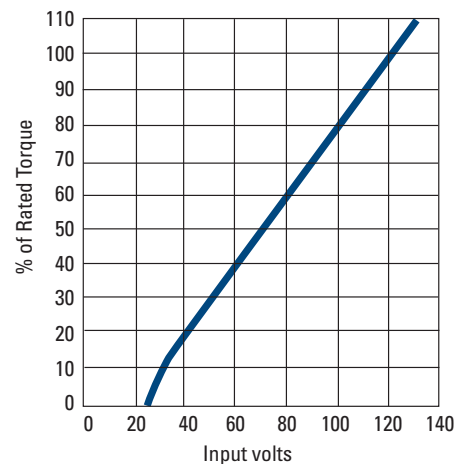

Speed Versus Frequency

The speed of a synchronous motor is directly proportional to the applied frequency, as shown in the Speed vs. Frequency chart. However, because the winding impedance is also a function of frequency it is necessary to adjust the voltage, to provide a constant current and torque at different excitation frequencies. The voltage required at a specific frequency can be obtained from the Voltage vs. Frequency curve. When a two-phase motor is operated from a two-phase source or a three-phase motor is operated from a three-phase source, it is only necessary to change the voltage and frequency to obtain the desired synchronous speed. When operating from a single-phase source it is necessary to change the values of the phase shifting components at each new frequency to provide the required phase shift.

Speed Versus Frequency

Frequency (Hertz)	Speed 72 rpm at 60 Hertz Models
10	12
20	24
30	36
40	48
50	60
60	72
70	84
80	96

Holding Torque

The permanent magnet construction of a Kollmorgen motor provides a small residual torque which helps hold the motor shaft in position when the motor is de-energized. When additional holding torque is required, DC current can be applied to one winding when the ac input is removed. DC current can also be applied to both windings if more holding torque is needed. The diagrams show typical connections for applying DC current to increase holding torque. Contact customer support for voltage, current and holding torque specifications.

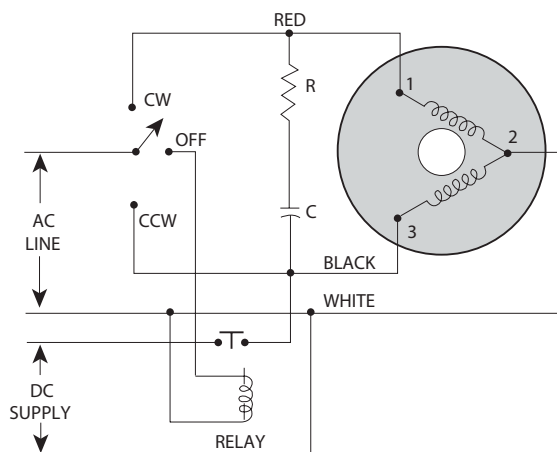

Typical Voltage Versus Frequency for a Kollmorgen Motor

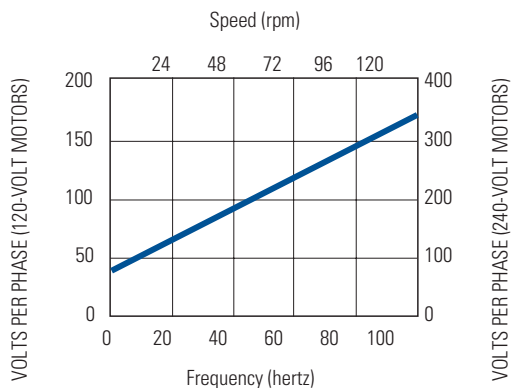

Synchronous Motor Performance Summary

A comprehensive range of AC synchronous motor products including continuous torque, high torque to meet a wide range of application requirements. For products not included in this catalog go to [www.electromate.com](#) for information about other Kollmorgen synchronous motor products.

ts

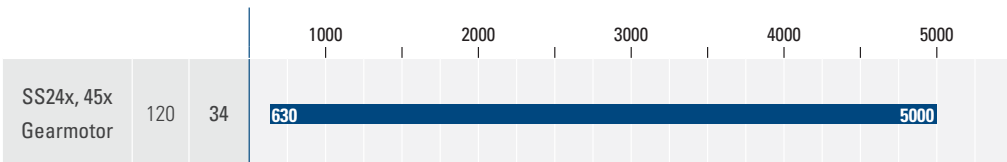
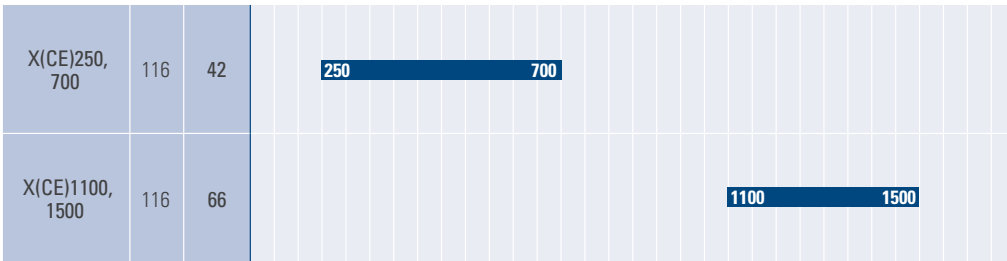
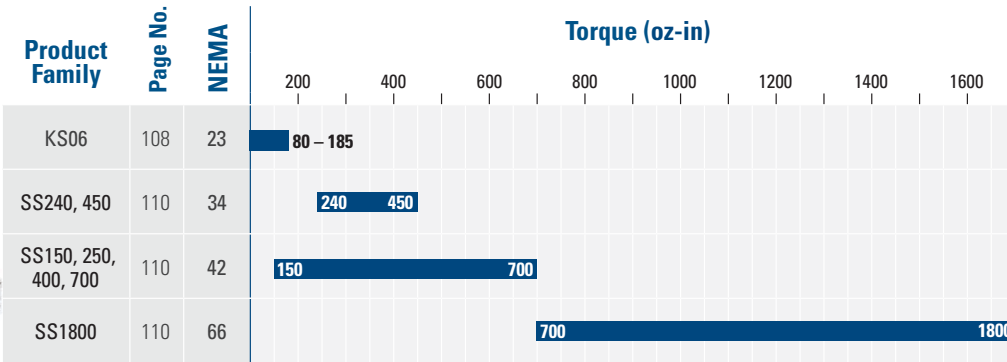

Product Family	Page No.	NEMA	Phases	Options			
				Leaded	Terminal Box	Rear Shaft	
KS06	108	23	1Ø	•	•	•	<ul style="list-style-type: none"> • 1Ø and 3Ø (SS240) • 72 rpm motor speed
SS240, 450	110	34	3Ø	•	•	•	<ul style="list-style-type: none"> • 60 rpm motor speed • 120 volt or 240 volt
SS150, 250,400, 700	110	42	1Ø	•	•	•	<ul style="list-style-type: none"> • Torques: 80 – 1800 • Fast starting, stopp
SS1800	110	66	1Ø	•	•	•	<ul style="list-style-type: none"> • Can be stalled inde
X(CE)250, 700	116	42	1Ø	•		•	<ul style="list-style-type: none"> • 1Ø models • X models meet UL • XCE models meet A • 60 and 50 Hz mode
X(CE)1100, 1500	116	66	1Ø	•		•	<ul style="list-style-type: none"> • 120 volt or 240 vol • Torques: 250 – 150 • Fast starting, stopp • Can be stalled inde
SS240, 450 Gearmotor	120	34	3Ø	•	•	•	<ul style="list-style-type: none"> • All the features of t • Gear reducers with • Torques: 634 - 5000

KSL06 Series AC Synchronous Motors

KSL06 SERIES AC SYNCHRONOUS MOTORS

General Specifications

- NEMA Size 23
- Latest high torque construction
- Motor torque up to 80 - 185 oz-in (0.56 - 1.33 Nm)
- 72 RPM @ 60 Hz
- 60 RPM @ 50 Hz
- 120 and 240 volt AC versions
- Patented RRC network for smoother operation
- Leaded or terminal box connections

Phases	1Ø
Operating Temperature	-20°C to +40°C
Insulation Class	Class B, 130°C
Insulation Voltage Rating	240 Vac
Insulation Resistance	100 Megohms

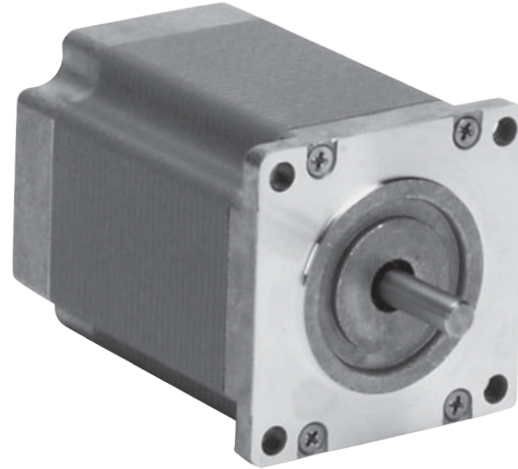

KSL06 Outline Drawings

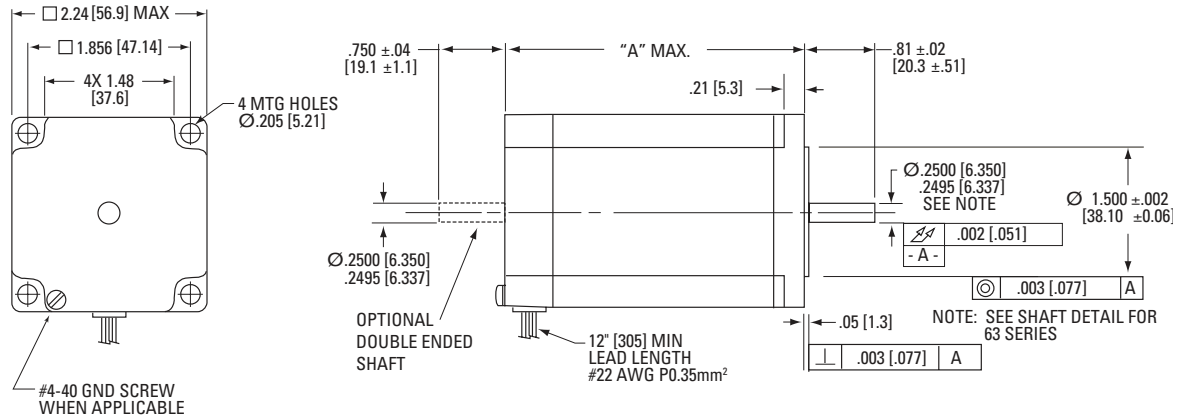

KSx063 Shaft Detail

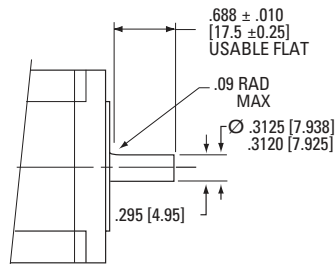

Model	"A" Max
KSL061	2.21 (56.1)
KSL062	3.06 (77.7)
KSL063	4.06 (103.1)

Dimensions in inches [mm]

KST06 Outline Drawing

Model	"A" Max
KST061	3.41 (86.6)
KST062	4.26 (108.2)
KST063	5.26 (133.6)

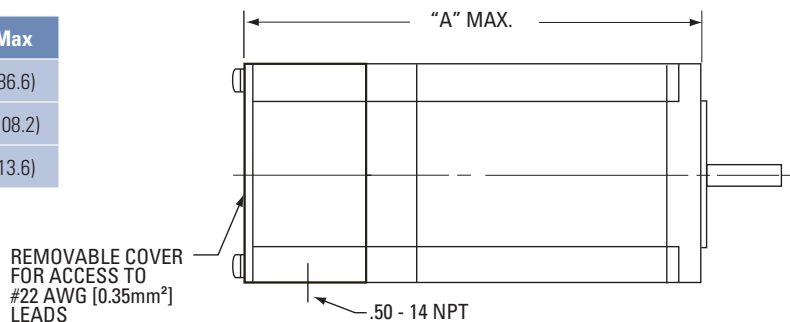

Dimensions in inches [mm]

KSL06 Performance Data

Model	Rated Torque oz-in (Nm)	Load Inertia* oz-in-s ² (kg-m ² x 10 ⁻³)	Line Current A (RMS/Ø)	Weight lb (kg)	Shaft Loading		Wiring Diag.	Phase Shifting Components				
					Radial Force lb (N)	Axial Force lb (N)		Resistor			Capacitor (240 Vac)	
								Resistor part no.	Ohms	Watts	Capacitor part no.	µF

60 Hz, 240 Vac, 72 RPM

KSL061T1Y	80 (0.56)	0.028 (0.20)	0.25	1.6 (0.73)	15 (67)	25 (110)	R/C	201052-033	1000	12	201053-038	2
KSL061T1Y	70 (0.49)	0.021 (0.15)	0.25	1.6 (0.73)	15 (67)	25 (110)	R/R/C	201052-034	600	12	201053-068	1.5
KSL062T1Y	140 (0.99)	0.084 (0.59)	0.35	2.3 (1.04)	15 (67)	25 (110)	R/C	201052-035	600	25	201053-044	3
KSL063T1Y	185 (1.31)	0.017 (1.2)	0.40	3.2 (1.45)	15 (67)	25 (110)	R/C	201052-049	400	50	201053-076	5

60 Hz, 120 Vac, 72 RPM

KSL062T2Y	140 (0.99)	0.095 (0.67)	0.15	2.3 (1.04)	15 (67)	25 (110)	R/C	201052-036	1100	25	201053-063	0.75
KSL063T2Y	185 (1.31)	0.11 (0.76)	0.20	3.2 (1.45)	15 (67)	25 (110)	R/C	201052-050	1000	25	201053-063	0.75

50 Hz, 240 Vac, 60 RPM

KSL062T2Y	140 (0.99)	0.095 (0.67)	0.15	2.3 (1.04)	15 (67)	25 (110)	R/C	201052-036	1100	25	201053-063	0.75
KSL063T2Y	185 (1.31)	0.11 (0.76)	0.20	3.2 (1.45)	15 (67)	25 (110)	R/C	201052-050	1000	25	201053-070	1

* This is the maximum rigidly attached load inertia the motor will reliably start. If the load is attached to the motor with a 5° flex coupling, the motor will start loads up to seven times listed.

See page 123 for KSL series connection diagrams.

SS Series AC Synchronous Motors

SS SERIES AC SYNCHRONOUS MOTORS

General Specifications

- NEMA sizes 34, 42, 66
- Motor torque from 240 – 1800 oz-in (1.69 – 12.7 Nm)
- 72 RPM @ 60 Hz
- 60 RPM @ 50 Hz
- 120 and 240 volt AC versions
- Single phase and three phase designs
- 3 phase design needs only a capacitor to operate from single-phase power, or operates directly from three-phase power
- Leaded or terminal box connections
- Planetary gearboxes available



Phases	1Ø & 3Ø
Operating Temperature	-20°C to +40°C
Insulation Class	Class B, 130°C
Insulation Voltage Rating	240 Vac
Insulation Resistance	100 Megohms

SS150, SS250, SS400, SS700 Outline Drawings

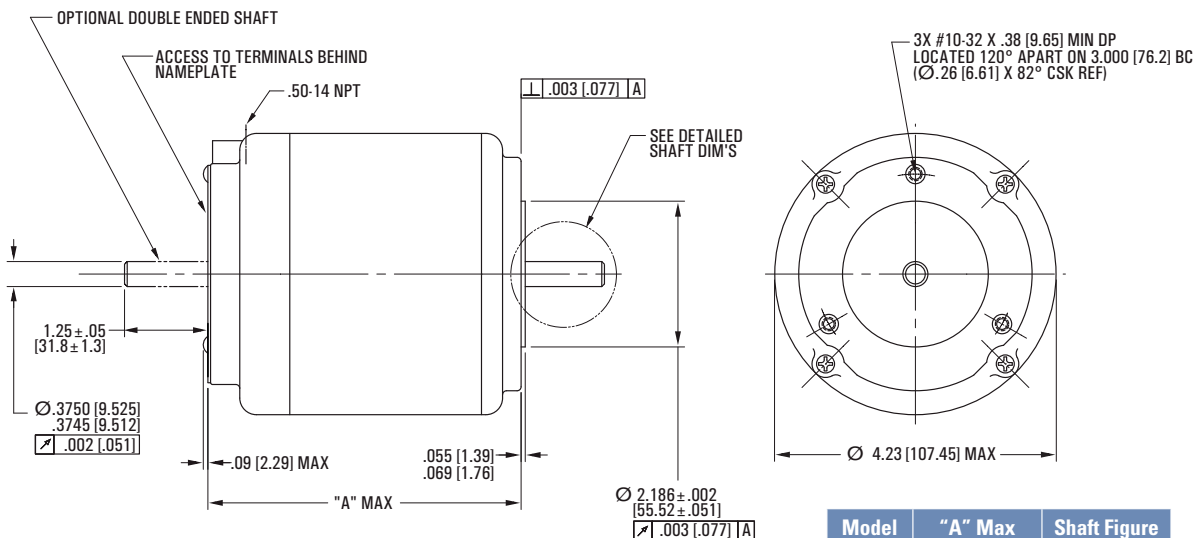

Dimensions in inches [mm]

Model	"A" Max	Shaft Figure
SS150	4.74 (120.4)	1
SS250	6.62 (168.1)	2
SS400	6.99 (15)	3

SS Series AC Synchronous Motors

SS SERIES AC SYNCHRONOUS MOTORS

SS240, SS450 Connection Options

Leaded Plug Construction

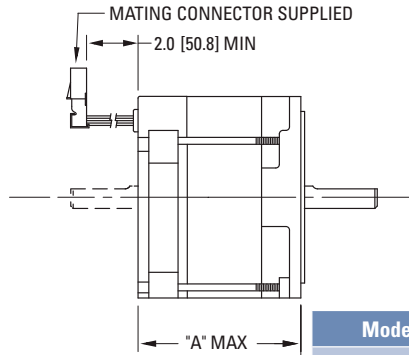

Model	"A" Max
SS241 / SS242	2.72 (69.1)
SS241 / SS452	4.32 (110)

Terminal Box Construction

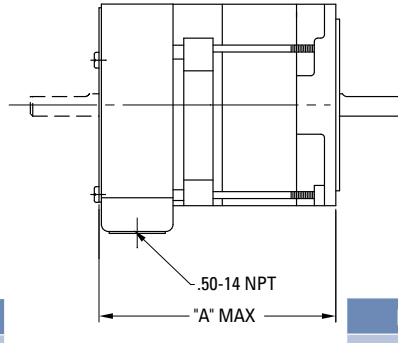

Model	"A" Max
SS241T / SS242T	4.05 (103)
SS241T / SS452T	5.65 (144)

Dimensions in inches [mm]

SS1800 Outline Drawings

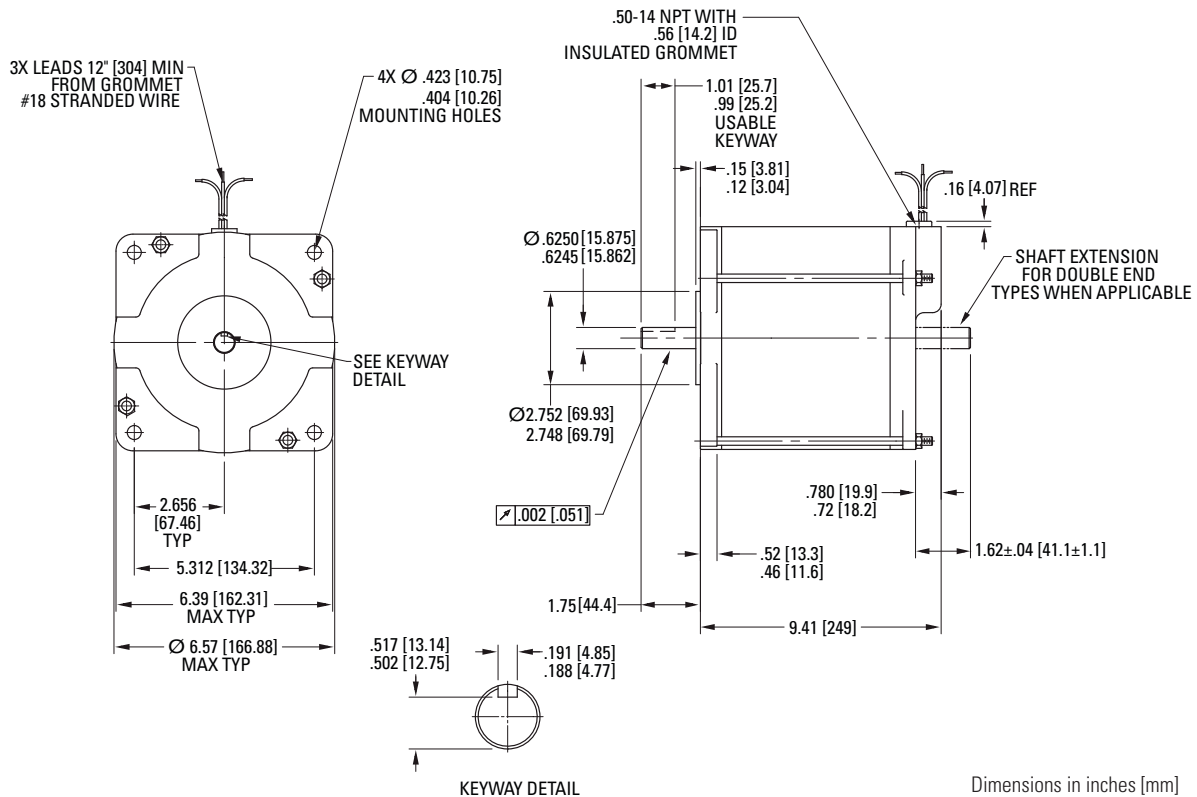

Dimensions in inches [mm]

SS 15x, 25x, 40x, 70x Performance Data

Model	Voltage	Rated Torque	Load Inertia*	Line Current	Weight	Shaft Loading		Wiring Diag.	Phase Shifting Components				
	Vac	oz-in (Nm)	oz-in-s ² (kg-m ² x 10 ⁻³)	A (RMS/Ø)	lb (kg)	Radial Force	Axial Force		Resistor			Capacitor (330 Vac)	
						lb (N)	lb (N)		Resistor part no.	Ohms	Watts	Capacitor part no.	µF

60 Hz, 120 Vac, 1Ø, 72 RPM

SS150B	120	150 (1.06)	0.062 (0.44)	0.45	8.0 (3.6)	25 (111)	50 (222)	C	201052-007	250	25	201053-005	3.75
SS250B	120	250 (1.77)	0.12 (0.88)	0.60	8.0 (3.6)	25 (111)	50 (222)	C	201052-013	150	50	201053-010	6.5
SS400B	120	400 (2.82)	0.18 (1.3)	0.60	12.3 (5.6)	25 (111)	50 (222)	C	201052-013	150	50	201053-010	6.5
SS700	120	700 (4.94)	0.42 (3.0)	1.1	15.5 (7.0)	25 (111)	50 (222)	C	201052-027	150	100	201053-032	12.5

60 Hz, 240 Vac, 1Ø, 72 RPM

SS152B	240	150 (1.06)	0.062 (0.44)	0.20	8.0 (3.6)	25 (111)	50 (222)	C	201052-030	1000	25	201053-023	1
SS252B	240	250 (1.77)	0.12 (0.88)	0.40	8.0 (3.6)	25 (111)	50 (222)	C	201052-015	500	50	201053-036	2
SS402B	240	400 (2.82)	0.18 (1.3)	0.40	12.3 (5.6)	25 (111)	50 (222)	C	201052-015	500	50	201053-012	1.75
SS702	240	700 (4.94)	0.42 (3.0)	0.55	15.5 (7.0)	25 (111)	50 (222)	C	201052-028	500	100	201053-030	3

50 Hz, 240 Vac, 1Ø, 60 RPM

SS152B	240	150 (1.06)	0.062 (0.44)	0.20	8.0 (3.6)	25 (111)	50 (222)	C	201052-030	1000	25	201053-034	1.5
SS252B	240	250 (1.77)	0.12 (0.88)	0.40	8.0 (3.6)	25 (111)	50 (222)	C	201052-015	500	50	201053-030	3
SS402B	240	400 (2.82)	0.54 (3.8)	0.40	12.3 (5.6)	25 (111)	50 (222)	C	201052-015	500	50	201053-035	2.5
SS702	240	700 (4.94)	n/a	0.55	15.5 (7.0)	25 (111)	50 (222)	C	201052-028	500	100	201053-028	4

* This is the maximum rigidly attached load inertia the motor will reliably start. If the load is attached to the motor with a 5° flex coupling, the motor will start loads up to seven times listed.

See page 123 for SS series connection diagrams.

SS Series AC Synchronous Motors

SS 24x, 45x Performance Data

Model	Voltage	Rated Torque	Load Inertia*	Line Current	Weight	Shaft Loading		Wiring Diagram	Phase Sifting Capacitor (250 Vac)	
	Vac	oz-in (Nm)	oz-in-s ² (kg-m ² x 10 ⁻³)	A (RMS/Ø)		Radial Force	Axial Force		Kit No.	µF

60 Hz, 120 Vac, 1Ø, 72 RPM

SS241	120	240 (1.69)	0.10 (0.73)	0.40	4.1 (1.9)	25 (111)	50 (222)	C	201053-037	7.5
SS451	120	450 (3.18)	0.23 (1.6)	0.80	6.5 (2.9)	25 (111)	50 (222)	C	201053-042	14

60 Hz, 240 Vac, 1Ø, 72 RPM

SS242	208/240	240 (1.69)	0.10 (0.73)	0.20	4.1 (1.9)	25 (111)	50 (222)	C	201053-038	2
SS452	208/240	450 (3.18)	0.31 (2.2)	0.30	6.5 (2.9)	25 (111)	50 (222)	C	201053-044	3

60 Hz, 208 - 240 Vac, 3Ø, 72 RPM

SS242	208/240	240 (1.69)	0.10 (0.73)	0.20	4.1 (1.9)	25 (111)	50 (222)	3Ø		
SS452	208	450 (3.18)	0.18 (1.3)	0.30	6.5 (2.9)	25 (111)	50 (222)	3Ø		

50 Hz, 240 Vac, 1Ø, 60 RPM

SS242	240	240 (1.69)	0.041 (0.29)	0.40	4.1 (1.9)	25 (111)	50 (222)	C	201053-038	2
SS242	220	240 (1.69)	0.041 (0.29)	0.40	4.1 (1.9)	25 (111)	50 (222)	C	201053-041	2.5
SS452	220/240	450 (3.18)	0.084 (0.59)	0.80	6.5 (2.9)	25 (111)	50 (222)	C	201053-061	4

50 Hz, 208 Vac, 3Ø, 60 RPM

SS242	208	240 (1.69)	0.17 (1.2)	0.20	4.1 (1.9)	25 (111)	50 (222)	3Ø		
SS452	208	450 (3.18)	0.18 (1.3)	0.30	6.5 (2.9)	25 (111)	50 (222)	3Ø		

* This is the maximum rigidly attached load inertia the motor will reliably start. If the load is attached to the motor with a 5° flex coupling, the motor will start loads up to seven times listed.

See page 123 for SS series connection diagrams.

SS 1800 Performance Data

Model	Voltage	Rated Torque	Load Inertia*	Line Current	Weight	Shaft Loading		Wiring Diag.	Phase Shifting Components				
	Vac	oz-in (Nm)	oz-in-s ² (kg-m ² x 10 ⁻³)	A (RMS/Ø)	lb (kg)	Radial Force	Axial Force		Resistor			Capacitor (330 Vac)	
						lb (N)	lb (N)		Resistor part no.	Ohms	Watts	Capacitor part no.	µF
60 Hz, 120 Vac, 1Ø, 72 RPM													
SS1800	120	1800 (12.7)	2.0 (14)	4.0	45 (20)	50 (222)	100 (445)	R/C	201052-022	40	375	201053-020	60
60 Hz, 240 Vac, 1Ø, 72 RPM													
SS1800	240	1800 (12.7)	2.0 (14)	2.5	45 (20)	50 (222)	100 (445)	R/C	201052-023	130	375	201053-021	15
50 Hz, 240 Vac, 1Ø, 60 RPM													
SS1800	240	1800 (12.7)	2.0 (14)	2.5	45 (20)	50 (222)	100 (445)	R/C	201052-023	130	375	201053-021	15

* This is the maximum rigidly attached load inertia the motor will reliably start. If the load is attached to the motor with a 5° flex coupling, the motor will start loads up to seven times listed.

See page 123 for SS series connection diagrams.

X(CE) Series AC Synchronous Motors

X(CE) SERIES AC SYNCHRONOUS MOTORS

General Specifications

- NEMA Sizes 42, 66
- Latest high torque construction
- Motor torque up to 250 - 1500 oz-in (1.77 - 10.6 Nm)
- X = Meets UL Class 1, Group D requirements
- XCE = Meets CE0081  II2 G Exd IIC T
- 72 rpm @ 60 Hz
- 60 rpm @ 50 Hz
- 120 and 240 volt AC versions
- Leded or terminal box connections

Phases	1Ø
Operating Temperature	-20°C to +40°C
Insulation Class	Class B, 130°C
Insulation Voltage Rating	240 Vac
Insulation Resistance	100 Megohms

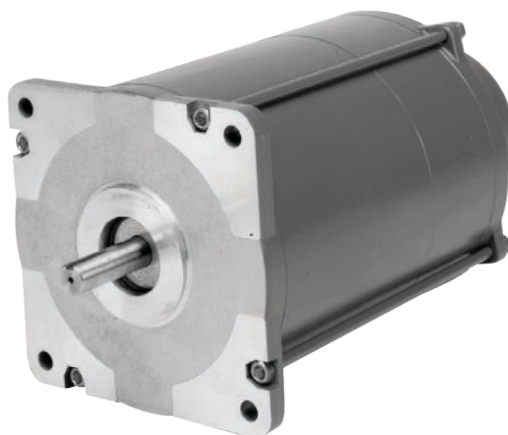

X(CE) 25x, 70x Outline Drawings

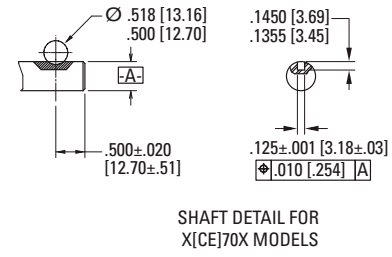
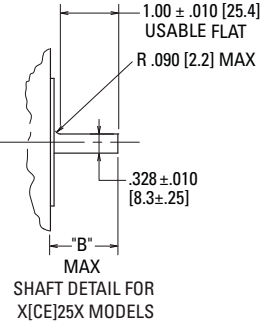
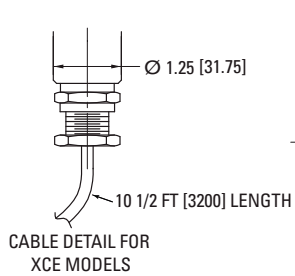
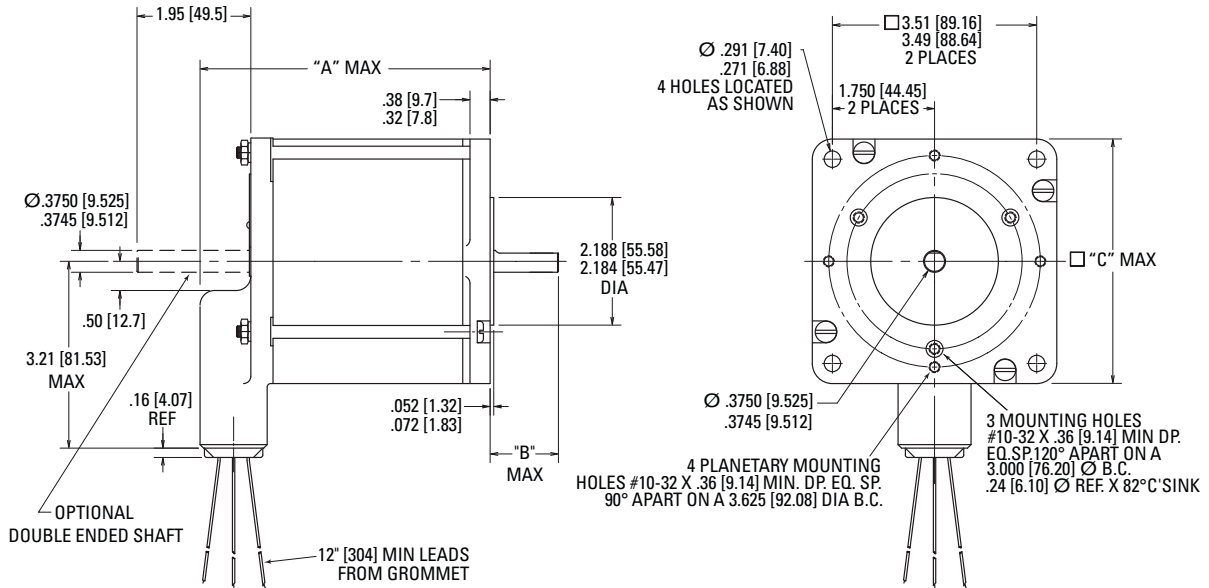

Model	"A" Max	"B" Max	"C" Max
X250 / X252	5.06 (129)	1.17 (29.7)	4.20 (107)
XCE250 / XCE252	5.70 (145)	1.17 (29.7)	4.50 (114)
X700	7.45 (189)	1.38 (35.1)	4.20 (107)
XCE700 / XCE702	8.06 (205)	1.38 (35.1)	4.50 (114)

Dimensions in inches [mm]

X(CE) Series AC Synchronous Motors

X(CE) SERIES AC SYNCHRONOUS MOTORS

X(CE) 110x, 150x Outline Drawings

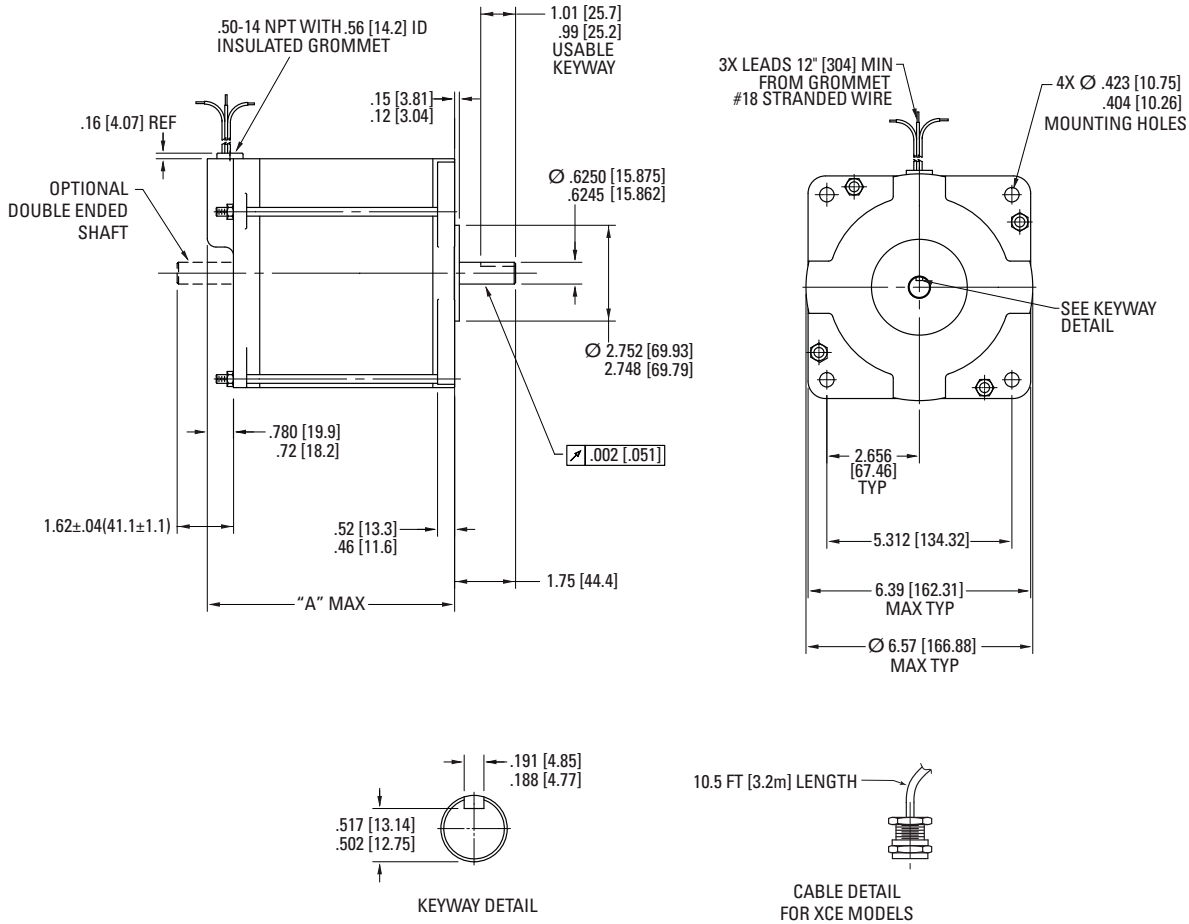

Dimensions in inches [mm]

Model	"A" Max
X1100 / X1102	7.1 (180)
XCE1100 / XCE1102	7.60 (193)
X1500 / X1502	8.41 (214)
XCE700 / XCE702	8.91 (226)

X(CE) 25x, 70x, 110x, 150x Performance Data

Model	Voltage	Rated Torque	Load Inertia*	Line Current	Weight	Shaft Loading		Wiring Diag.	Phase Shifting Components				
	Vac	oz-in (Nm)	oz-in-s ² (kg-m ² x 10 ⁻³)	A (RMS/Ø)	lb (kg)	Radial Force	Axial Force		Resistor			Capacitor (330 Vac)	
						lb (N)	lb (N)		Resistor part no.	Ohms	Watts	Capacitor part no.	µF
60 Hz, 120 Vac, 1Ø, 72 RPM													
X(CE)250	120	250 (1.77)	0.12 (0.88)	0.60	9.0 (4.1)	25 (111)	50 (222)	R/C	201052-013	150	50	201053-010	6.5
X(CE)700	120	700 (4.94)	0.43 (3.0)	1.1	n/a	n/a	n/a	R/C	201052-027	150	100	201053-032	12.5
X(CE)1100	120	1100 (7.77)	0.37 (2.6)	3.0	36 (16)	50 (222)	100 (445)	R/C	201052-025	100	160	201053-026	17.5
X(CE)1500	120	1800 (10.6)	0.50 (3.5)	3.0	42 (19)	50 (222)	100 (445)	R/C	201052-020	55	375	201053-014	30
60 Hz, 240 Vac, 1Ø, 72 RPM													
X(CE)252	240	250 (1.77)	0.12 (0.88)	0.4	9.0 (4.1)	25 (111)	50 (222)	R/C	201052-015	500	50	201053-012	1.75
X(CE)702	240	700 (4.94)	0.43 (3.0)	0.6	n/a	n/a	n/a	R/C	201052-028	500	100	20153-030	3
X(CE)1102	240	1100 (7.77)	0.37 (2.6)	1.5	36 (16)	50 (222)	100 (445)	R/C	201052-026	400	160	201053-028	4
X(CE)1502	240	1800 (10.6)	0.50 (3.5)	1.5	42 (19)	50 (222)	100 (445)	R/C	201052-018	250	200	201053-016	8
50 Hz, 240 Vac, 1Ø, 60 RPM													
X(CE)252	240	250 (1.77)	0.12 (0.88)	0.4	9.0 (4.1)	25 (111)	50 (222)	R/C	201052-015	500	50	201053-012	1.75
X(CE)702	240	700 (4.94)	0.43 (3.0)	0.6	n/a	n/a	n/a	R/C	201052-028	500	100	201053-028	4
X(CE)1102	240	1100 (7.77)	0.37 (2.6)	1.5	36 (16)	50 (222)	100 (445)	R/C	201052-026	400	160	201053-029	6
X(CE)1502	240	1800 (10.6)	0.50 (3.5)	1.5	42 (19)	50 (222)	100 (445)	R/C	201052-018	250	200	201053-019	9

* This is the maximum rigidly attached load inertia the motor will reliably start. If the load is attached to the motor with a 5° flex coupling, the motor will start loads up to seven times listed.

See page 123 for X(CE) series connection diagrams.

AC Synchronous Gearmotors and Gearbox Kits

AC SYNCHRONOUS GEARMOTORS AND GEARBOX KITS

Kollmorgen gearmotors mate NEMA 34 AC synchronous motors with step-down gearboxes for applications where slow shaft speeds or high torque are needed. The rugged gearbox developed for Kollmorgen gearmotors has been designed to allow high output torque ratings, while providing long life. The gearboxes are permanently lubricated and no scheduled maintenance is needed. Gearbox efficiency is 88% to 68% depending on the number of stages. The output shaft of the gear assembly is provided with a standard Woodruff key for easy and positive coupling to the load.

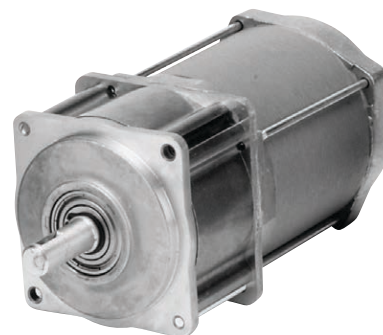

- Ratios from 3:1 to 125:1
- Up to 5000 oz-in (35.3 Nm) torque
- Typical output shaft backlash is 2 degrees
- Maintenance free
- Kits for field installation to NEMA 34 motors

For more options regarding gearhead sizes or ratios refer to the XTRUE™ planetary gearhead series on page 94.

SS Size 34 Gearmotor Outline Drawings

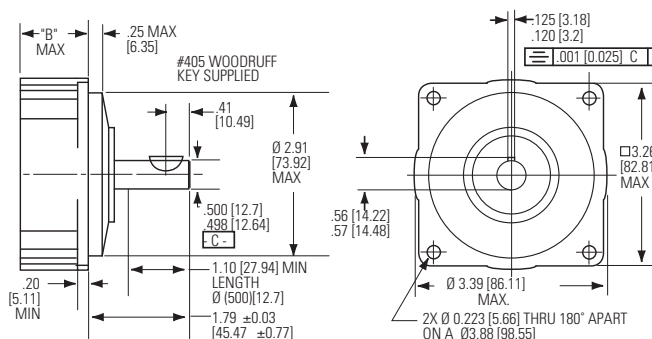

Dimensions in inches [mm]

SS Size 34 Gearmotor Performance Data

Gearmotor Model Number		Gear Ratio	Speed (rpm)		Minimum Torque oz-in (Nm)	Maximum Rigidly Attached Load Inertia		
			@ 60 Hz	@ 50 Hz		1Ø, 60 Hz oz-in-s ² (kg-m ²)	1Ø, 50 Hz oz-in-s ² (kg-m ²)	3Ø oz-in-s ² (kg-m ²)
120 V	240 V							
SS241LG3	SS242LG3	3:1	24	20	634 (4.48)	0.79 (0.0056)	0.30 (0.0021)	0.793 (0.0056)
SS241LG4	SS242LG4	4:1	18	15	845 (5.96)	1.44 (0.0102)	0.57 (0.0040)	1.44 (0.0102)
SS241LG5	SS242LG5	5:1	14.4	12	1060 (7.46)	2.27 (0.0160)	0.89 (0.0063)	2.27 (0.0160)
SS241LG9	SS242LG9	9:1	8	6.667	1660 (11.7)	6.16 (0.0435)	2.29 (0.0162)	6.16 (0.0435)
SS241LG12	SS242LG12	12:1	6	5	2220 (15.7)	11.3 (0.0798)	4.40 (0.0311)	11.3 (0.0798)
SS241LG15	SS242LG15	15:1	4.8	4	2770 (19.6)	17.8 (0.126)	7.01 (0.0495)	17.8 (0.126)
SS241LG16	SS242LG16	16:1	4.5	3.75	2960 (20.9)	20.1 (0.142)	7.86 (0.0555)	20.1 (0.142)
SS241LG20	SS242LG20	20:1	3.6	3	3700 (26.1)	31.6 (0.223)	1.25 (0.00880)	31.6 (0.223)
SS241LG25	SS242LG25	25:1	2.88	2.4	4620 (32.6)	49.4 (0.349)	19.5 (0.138)	49.4 (0.349)
SS241LG27	SS242LG27	27:1	2.667	2.222	4410 (31.1)	49.0 (0.346)	18.2 (0.129)	49.0 (0.346)
SS241LG36	SS242LG36	36:1	2	1.667	5000 (35.3)	89.8 (0.634)	35.0 (0.247)	89.8 (0.634)
SS241LG45	SS242LG45	45:1	1.6	1.333	5000 (35.3)	141 (0.998)	55.7 (0.393)	141 (0.998)
SS241LG48	SS242LG48	48:1	1.5	1.25	5000 (35.3)	160 (1.13)	(625) 4.42	160 (1.13)
SS241LG60	SS242LG60	60:1	1.2	1	5000 (35.3)	251 (1.77)	991 (7.00)	251 (1.77)
SS241LG64	SS242LG64	64:1	1.125	0.938	5000 (35.3)	284 (2.01)	1110 (7.85)	284 (2.01)
SS241LG75	SS242LG75	75:1	0.96	0.8	5000 (35.3)	393 (2.77)	1550 (10.9)	393 (2.77)
SS241LG80	SS242LG80	80:1	0.9	0.75	5000 (35.3)	447 (3.15)	1760 (12.4)	447 (3.15)
SS241LG100	SS242LG100	100:1	0.72	0.6	5000 (35.3)	698 (4.93)	2760 (19.5)	698 (4.93)
SS241LG125	SS242LG125	125:1	0.576	0.48	5000 (35.3)	1090 (7.70)	4310 (30.4)	1090 (7.70)
SS451LG3	SS452LG3	3:1	24	20	1190 (8.40)	1.77 (0.0125)	0.62 (0.0044)	1.44 (0.0102)
SS451LG4	SS452LG4	4:1	18	15	1580 (11.2)	3.19 (0.0225)	1.15 (0.0081)	2.61 (0.0184)
SS451LG5	SS452LG5	5:1	14.4	12	1980 (14.0)	5.00 (0.0353)	1.80 (0.0127)	4.08 (0.0288)
SS451LG9	SS452LG9	9:1	8	6.667	3120 (22.0)	13.9 (0.0983)	4.87 (0.0344)	11.3 (0.0800)
SS451LG12	SS452LG12	12:1	6	5	4160 (29.4)	25.1 (0.177)	9.01 (0.0636)	20.5 (0.145)
SS451LG15	SS452LG15	15:1	4.8	4	5000 (35.3)	39.3 (0.278)	14.2 (0.100)	32.1 (0.227)
SS451LG16	SS452LG16	16:1	4.5	3.75	5000 (35.3)	44.6 (0.315)	16.0 (0.113)	36.4 (0.257)
SS451LG20	SS452LG20	20:1	3.6	3	5000 (35.3)	69.9 (0.494)	25.2 (0.178)	57.1 (0.404)
SS451LG25	SS452LG25	25:1	2.88	2.4	5000 (35.3)	109 (0.771)	39.4 (0.279)	89.3 (0.631)
SS451LG27	SS452LG27	27:1	2.667	2.222	5000 (35.3)	111 (0.781)	38.7 (0.274)	90.1 (0.636)

For more options regarding gearhead sizes or ratios refer to the XTRUE™ planetary gearhead series on page 94.

AC Synchronous Gearmotors and Gearbox Kits

Field Installable NEMA Size 34 Gearhead Kits

Gearbox Ratio	Kit Part Number	"B" Body Length	Typical Input Shaft Lost Motion	Typical Output Shaft Backlash	Reflected Moment of Inertia	Efficiency %
		in (mm)	Degrees	Degrees	oz-in-s ² (kg-cm ²)	
3:1	220763-003	1.19 (30.2)	6	2	0.00435 (0.307)	85
4:1	220763-004		7		0.00144 (0.102)	
5:1	220763-005		8		0.00086 (0.061)	
9:1	220763-009	1.81 (46.0)	43	2	0.00476 (0.336)	77
12:1	220763-012		61		0.00170 (0.120)	
15:1	220763-015		81		0.000991 (0.070)	
16:1	220763-016		58		0.00153 (0.108)	
20:1	220763-020		65		0.00095 (0.067)	
25:1	220763-025		73		0.00091 (0.064)	
27:1	220763-027	2.38 (60.5)	109	2	0.00473 (0.334)	68
36:1	220763-036		110		0.00170 (0.120)	
45:1	220763-045		112		0.000991 (0.070)	
48:1	220763-048		113		0.00153 (0.108)	
60:1	220763-060		115		0.00095 (0.067)	
64:1	220763-064		116		0.00153 (0.108)	
75:1	220763-075		118		0.00091 (0.064)	
80:1	220763-080		119		0.00095 (0.067)	
100:1	220763-100		124		0.00091 (0.064)	
125:1	220763-125		130		0.00091 (0.064)	

Note: Maximum shaft loading for all gearhead kits is 150 lb (667 N) Radial, 100 lb (445 N) Axial

For more options regarding gearhead sizes or ratios refer to the XTRUE™ planetary gearhead series on page 94.

AC Synchronous Motor Connection Diagrams

AC SYNCHRONOUS MOTOR CONNECTION DIAGRAMS

Single-Phase KS, SS and X(CE) Motor Connection Diagrams

R/C Connection

Single-Phase Operation

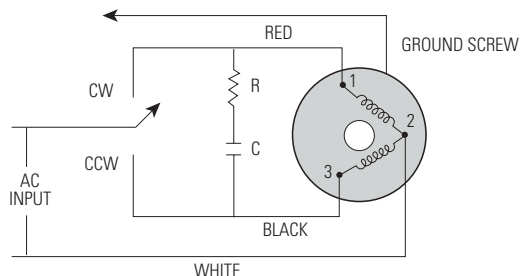

NOTE:
 1 - Direction or rotation is determined when viewed from end opposite mounting surface.

R/R/C Connection

Single-Phase Operation

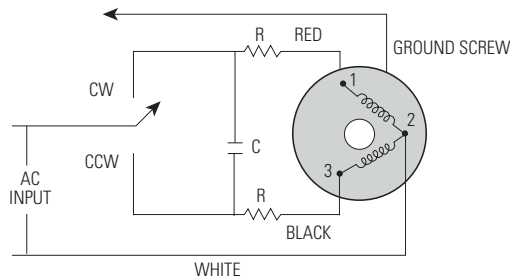

2 - Number in diagrams represent terminal connection when motors are supplied with terminal boards.

Three-Phase SS Motor Connection Diagrams

C Connection

Single-Phase Operation

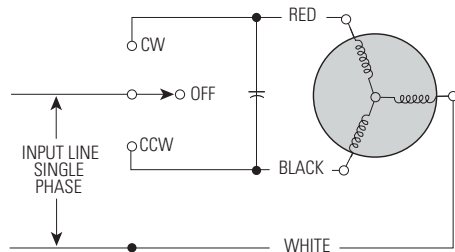

DIRECTION OF ROTATION DETERMINED WHEN VIEWED FROM NAMEPLATE END OF MOTOR.

3Ø Connection

Three-Phase Operation

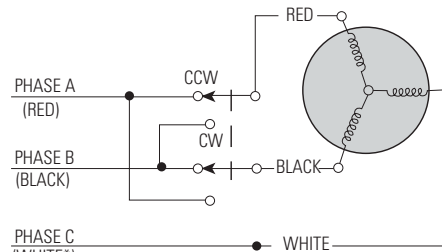

DIRECTION OF ROTATION DETERMINED WHEN VIEWED FROM NAMEPLATE END OF MOTOR.

* - WHITE IS NOT "NEUTRAL"

AC Synchronous Motor Application Guide

Parallel Motor Operation

Two or more Kollmorgen motors may be operated simultaneously from the same power source, if the total current requirement does not exceed the current capability of the supply. However, due to the motor starting characteristics, mechanical synchronization of the motors is not practical. One motor may achieve running speed within 5 milliseconds while a second motor, because of its at rest position, may require 25 milliseconds to achieve running speed.

Starting High Inertia Loads

The motor charts show the maximum load inertia that each motor model can start. Inertial loads as high as five to ten times these ratings can be started if a flexible coupling is used between the motor shaft and the load. The coupling should allow approximately 5° of shaft rotation before the full load is applied to the shaft. Rubber couplings are often used, as are chain drives with sufficient slack to allow the necessary shaft motion. Timing belts are also used, and in most cases will provide adequate flexing while providing smooth and quiet transmission of power.

Effects of Speed Reduction Gearing on Torque and Inertia

The combination of reduction gearing and a Kollmorgen motor provides increased torque as well as a lower operating speed. Output speed is decreased and torque increased by the factor of the gear ratio used minus losses due to gear train inefficiency. Gear losses are typically around 10% per mesh. Step-down gearing offers even greater gains in inertial load rating, since the inertia moving capability increases by the square of the gear ratio. Timing belts and pulleys can be used in place of gears for speed reduction and will provide the added benefit of flexible coupling.

Switch Contact Protection

In some applications it may be desirable to protect the switch contacts from arcing and from transient voltages generated during switching. The most common method is the addition of resistors and capacitors across the switch contacts as shown in the diagram. Recommended values of the components are: resistor, 330 ohm, 1 watt; capacitor, 0.1 mfd, 250 Vac.

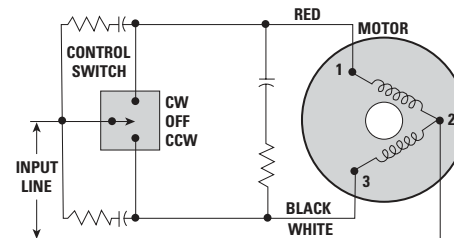

SWITCH PROTECTION NETWORK FOR AC OPERATION OF STANDARD MODELS

Temperature Considerations

The motors are rated for a maximum free-air ambient temperature of 40° C (104°F). However, it is possible to operate in higher ambient temperatures or above rated voltages if the motors are mounted on metal plates or are forced-air cooled. Do not exceed the maximum motor case temperature of 100° C (212° F).

Coupling Motor to Load

Because of the extremely fast starting and stopping characteristics of a Kollmorgen AC synchronous motor, couplings, pulleys or other devices should be well secured to the motor shaft with the key provided, roll-pins, or set-screws.

If a coupling is to be press-fitted to the shaft, the motor must be held by the shaft (not by the gearbox or the motor case) when pressing the coupling in place. This will prevent damage to the motor bearings. The force used in pressing must not exceed the thrust force limit of the gearbox (100 pounds).

Selecting an AC Synchronous Motor

To select a synchronous motor first determine the torque and moment of inertia characteristics of the load, as presented to the motor. The following examples show how to calculate these requirements in both standard U.S. and metric units. If additional information or technical assistance is needed, contact Kollmorgen customer support. A representative will be pleased to help you select the best motor for your application. Once the requirements of the application including input voltage and frequency are known, refer to the rating shown on the motor charts and select the motor which best suits these requirements.

Torque

Torque (oz-in) = Fr

Where F = Force (in ounces) required to drive the load
r = Radius (in inches)

Force can be measured using a pull type spring scale. The scale may be attached to a string that is wrapped around a pulley or a hand wheel attached to the scale. If the scale reading is in pounds, it must be converted into ounces to obtain a torque rating in ounce-inches.

For example: A 4" diameter pulley requires a 2 pound pull on the scale to rotate it.

$$F = 2 \text{ pounds} \times 16 = 32 \text{ ounces}$$

$$r = 4" / 2 = 2"$$

$$\text{Torque} = 32 \times 2 = 64 \text{ oz-in}$$

Torque (Nm) = Fr

Where F = Force (N) required to drive the load
r = 0.05 m
Torque = 1.5 x 0.05 = 0.075 Nm

Force can be measured using a pull type spring scale. If the scale reading is calibrated in Kilograms, the scale reading must be multiplied by 9.8067 to obtain newtons. The scale should be attached to a string that is wrapped around a pulley or a hand wheel which is then attached to the load.

For example, a 10 cm diameter pulley requires a 1.5 newton (0.153 kg) pull on the scale to rotate it.

$$F = 1.5 \text{ newtons}$$

$$r = 0.05 \text{ m}$$

$$\text{Torque} = 1.5 \times 0.05 = 0.075 \text{ Nm}$$

Gears and Pulleys

When the load is driven through gears or pulleys, the required motor torque is changed by the overall ratio.

For example, if the load is 90 ounce-inches (0.636 Nm) and the step-down ratio is 3:1, the required torque would be 30 ounce-inches (0.212 Nm)

Load inertia presented to the motor is changed by the square of the ratio. For example, with a load inertia of 16 oz-in-s² (0.113 kg-m) and a 2:1 step-down ratio, the effective inertia would be 4 oz-in-s² (0.0308 kg-m²) plus the inertia of the first gear or pulley.

Inertia

Moment of Inertia (oz-in-s²)

$$(\text{oz-in-s}^2) = \frac{Wr^2}{772.2} \text{ for a disk or } (\text{oz-in-s}^2) = \frac{W}{772.2} (r_1^2 - r_2^2) \text{ for a cylinder}$$

Where W = Weight in ounces
r = Radius (in inches)

For example: A load is 8" diameter solid gear weighing 8 ounces

$$W = 8 \text{ oz}$$

$$r = 8" / 2 = 4"$$

$$\text{Moment Of Inertia} = \frac{8 \times (4)^2}{772.2} = 0.166 \text{ oz-in-s}^2$$

Moment Of Inertia (kg-m²)

$$J = \frac{Wr^2}{196134} \text{ for a disk or } J = \frac{(r_1^2 - r_2^2)}{196134} \text{ for a cylinder}$$

Where W = newtons
r = cm

For example: A load is 20 cm diameter solid gear weighing 0.25 newtons.

$$W = .25 \text{ newtons}$$

$$r = 10 \text{ cm}$$

$$\text{Moment Of Inertia} = \frac{.25 \times 10^2}{196134} = 0.0001275 \text{ kg-m}^2$$

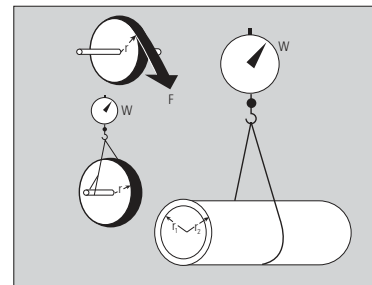

Optimized Solutions

With Kollmorgen, there's always a way. Because we have decades of experience in developing optimized solutions for motion applications, you can be confident that we can provide the answer to your motion challenges. We have a huge breadth of standard products that can be modified in varying degrees, or we can develop custom motor and electronic products for true optimization.

Working with our proven portfolio of products, we can deliver solutions quickly, often with recognized cost efficiencies and reduced lead times. That means rapid prototyping, a shorter design cycle and getting to market faster. We do it all, because motion matters.

Optimized Solutions

Whether it's modifying a product from our standard catalog or a white sheet design for a custom solution, you can rely on decades of Kollmorgen expertise to solve your motion challenges and help your machine stand out from the crowd.

Modified Standard

Because our application expertise runs deep and our product portfolio is so broad, we can take any standard product and modify it a lot or a little to suit many needs – in a very rapid time frame. This approach ensures quality, performance and reliability by leveraging our proven track record.

Kollmorgen application engineers have a great deal of experience helping OEM engineers achieve their objectives. Typical modifications include shaft alterations, feedback type, mounting dimensions, connectors, and making components more rugged, vacuum-rated, radiation- and explosion-proof.

Custom Products

With motion as our core capability, we bring a significant history of innovation to today's engineering challenges. We leverage our design and engineering excellence and technical knowledge to deliver creative new solutions for virtually any need. Our vast experience also helps us deliver a custom product in a surprisingly short time. If you can conceive it, we can make it happen.

Structured Development Process

OPTIMIZED SOLUTIONS

Working from our broad standard product portfolio, we create fully optimized solutions through the combination of off-the-shelf products, modified standard products and completely custom components. Our proven components and technology are the foundation for all of our solutions, expediting the design cycle and ensuring optimum performance for any application.

We follow a strict and efficient development process from initial concept to volume production. This ensures that products we develop meet customer needs, are cost effective to manufacture and move quickly from prototype to production. Customer involvement is key to our process, with ongoing collaboration throughout the initiative and multiple approval points to ensure a smooth, successful design cycle from beginning to end.

Why You Should Partner with Kollmorgen

- Experienced application engineers help define a customer’s needs and identify the optimal Kollmorgen products and technologies
- Products optimized or developed by cross-functional teams to meet customer needs
- Rapid prototyping
- Smooth transition from prototype designs to sustainable and cost effective manufacturing
- Industry-proven quality, performance, and delivery
- Proven technology building blocks mitigate risks of customization

Optimized Solutions Process

Comprehensive design, manufacture and test capabilities ensure the end product meets the customer performance specifications and quality requirements. Our skilled engineering team works directly with each customer throughout the process, quickly taking the prototype to full production.

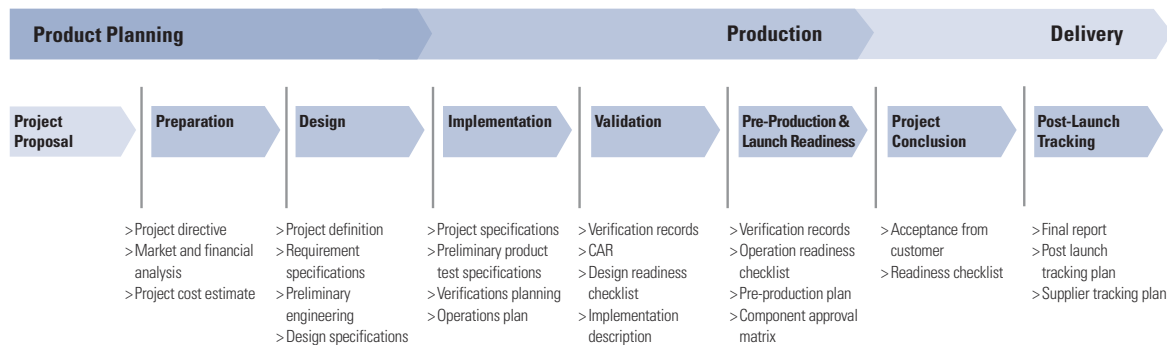

Proven Design Capabilities

OPTIMIZED SOLUTIONS

Motor Solutions

- Brushed, brushless and stepper motor building blocks used in frameless or housed configurations
- Designed for agency compliance (UL, CE)
- Voltage ratings from 48 Vdc – 600 Vdc, with capabilities in 800 Vdc and up
- Continuous torques from 0.5 Nm – 29,000 Nm
- Proven performance and reliability in a customizable package

Drive Solutions

- Board-level or packaged solutions supporting single to multi-axis configurations
- Brushed or brushless servo drives, stepper, AC induction control
- Integrated controller and communications options
- Designed for agency approvals (UL 508C, EN 50178, EN 61000-6-6, EN 61800-3, CISPR 14-1, and others available)
- Proprietary technology and software can be embedded into the drive



Medical diagnostics drive optimized for form-factor, I/O and EMC

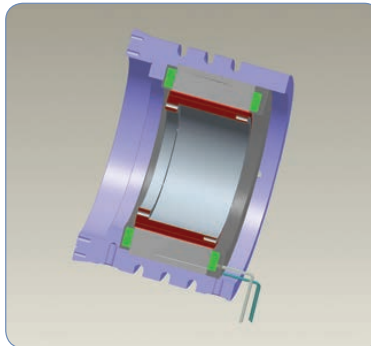

Frameless direct drive rotary motor with water cooling features

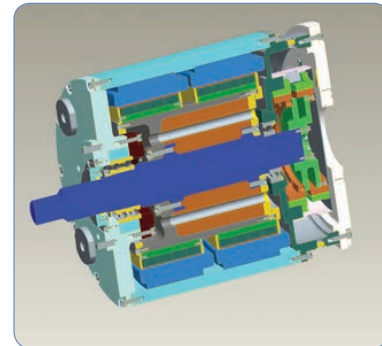

Custom submersible motor

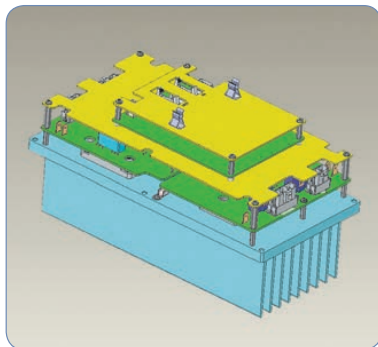

2-axis drive for high-power robotics, optimized for form-factor and communications interface

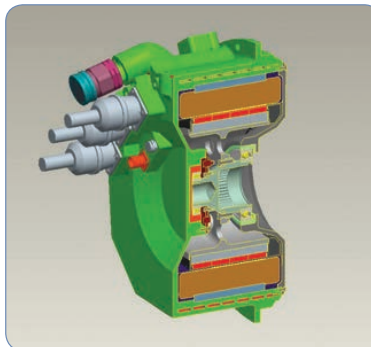

200 kW electric starter/generator

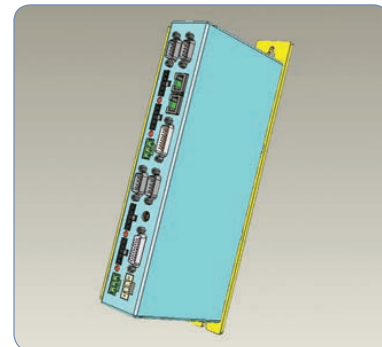

4-axis stepper drive using SynqNet

Motors and Electronics

Optimized for	Application
Reliability	Implantable heart pumps, military, remote equipment
Precision	Pick and place, satellite tracking, film processing
Package size	Medical imaging, ground based telescopes, aircraft instrumentation
Weight	Land vehicles, portable equipment, aircraft
Smooth operation	Medical respirators, high precision robotics, printing and textile machines
Harsh environments	Deep sea, outer space, high shock and vibration, extreme temperatures

Model Nomenclature

MODEL NOMENCLATURE

P5000 Stepper Drive

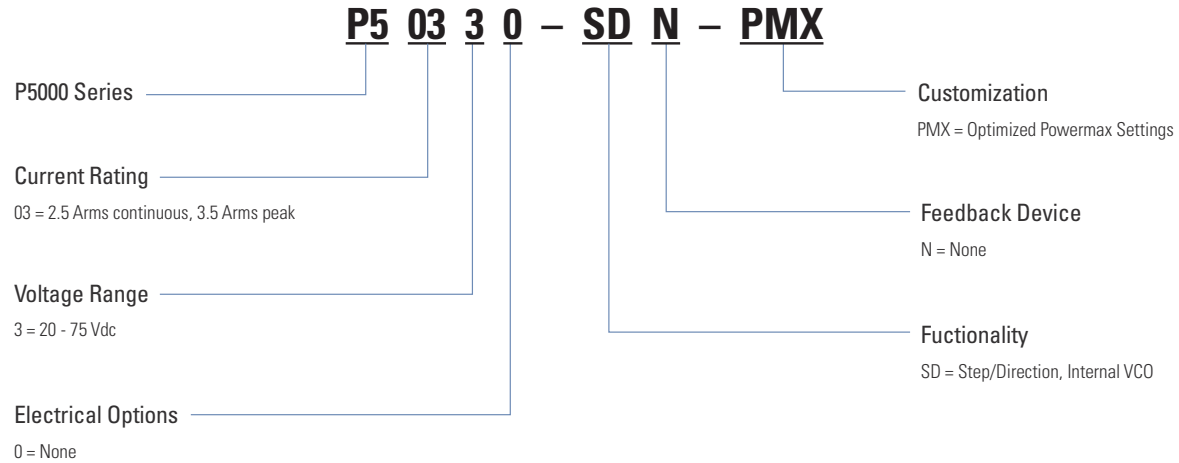

P6000 Stepper Drive

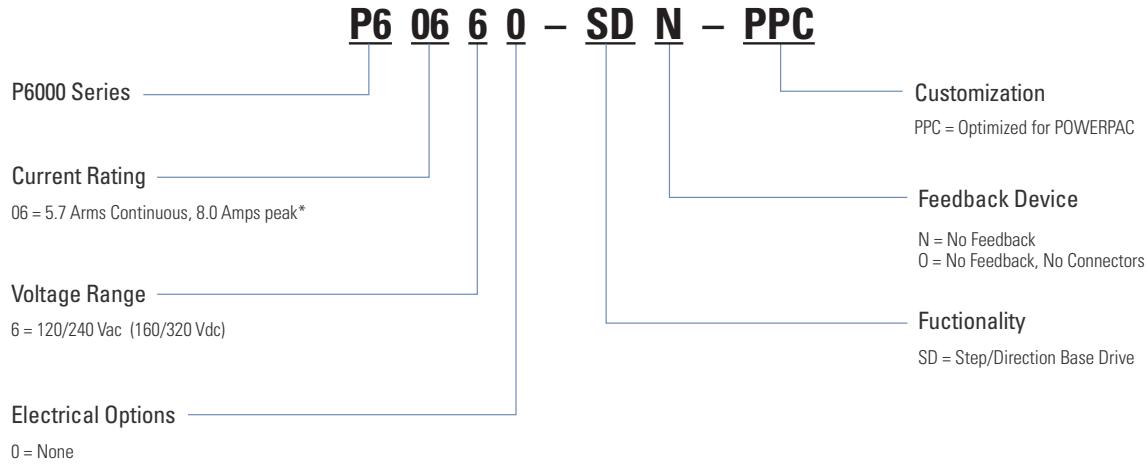

*Note: Switch selectable 0.3 – 5.7 Arms

Model Nomenclature

P7000 Stepper Drive

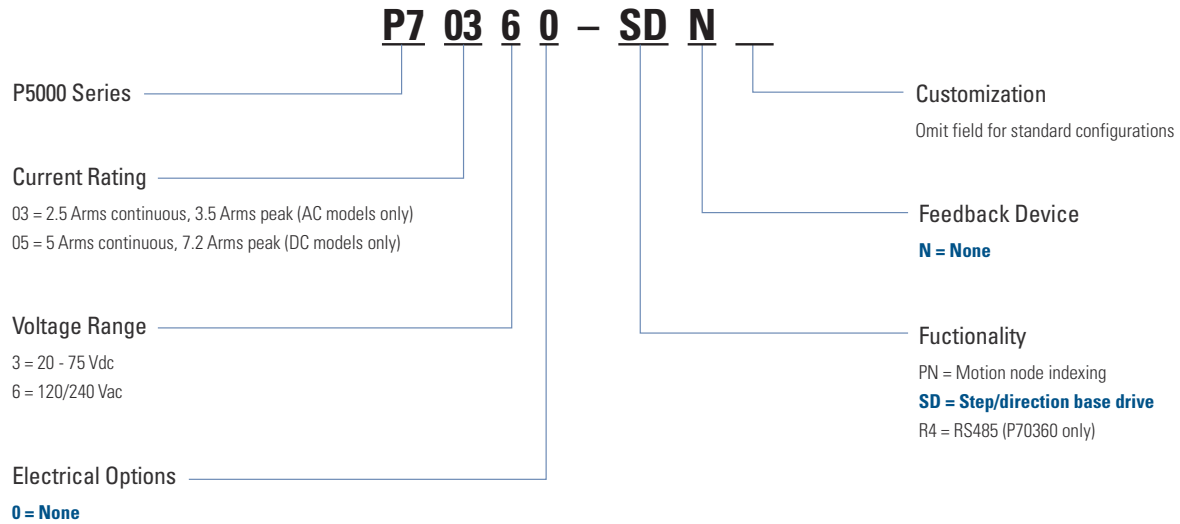

CT Series Stepper Motor

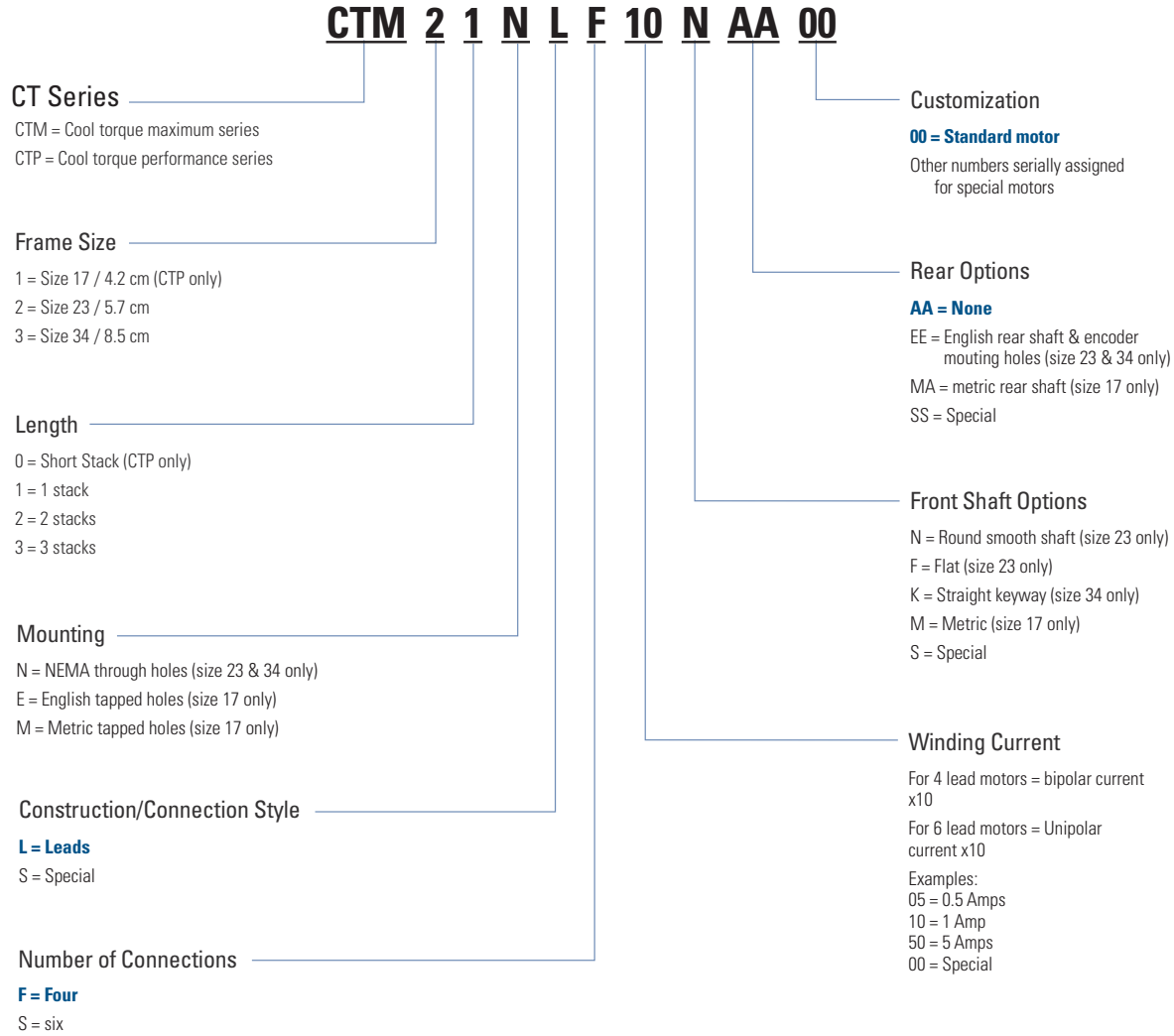

Note: Options shown in bold blue text are considered standard.

Model Nomenclature

MODEL NOMENCLATURE

T2 Series Stepper Motor

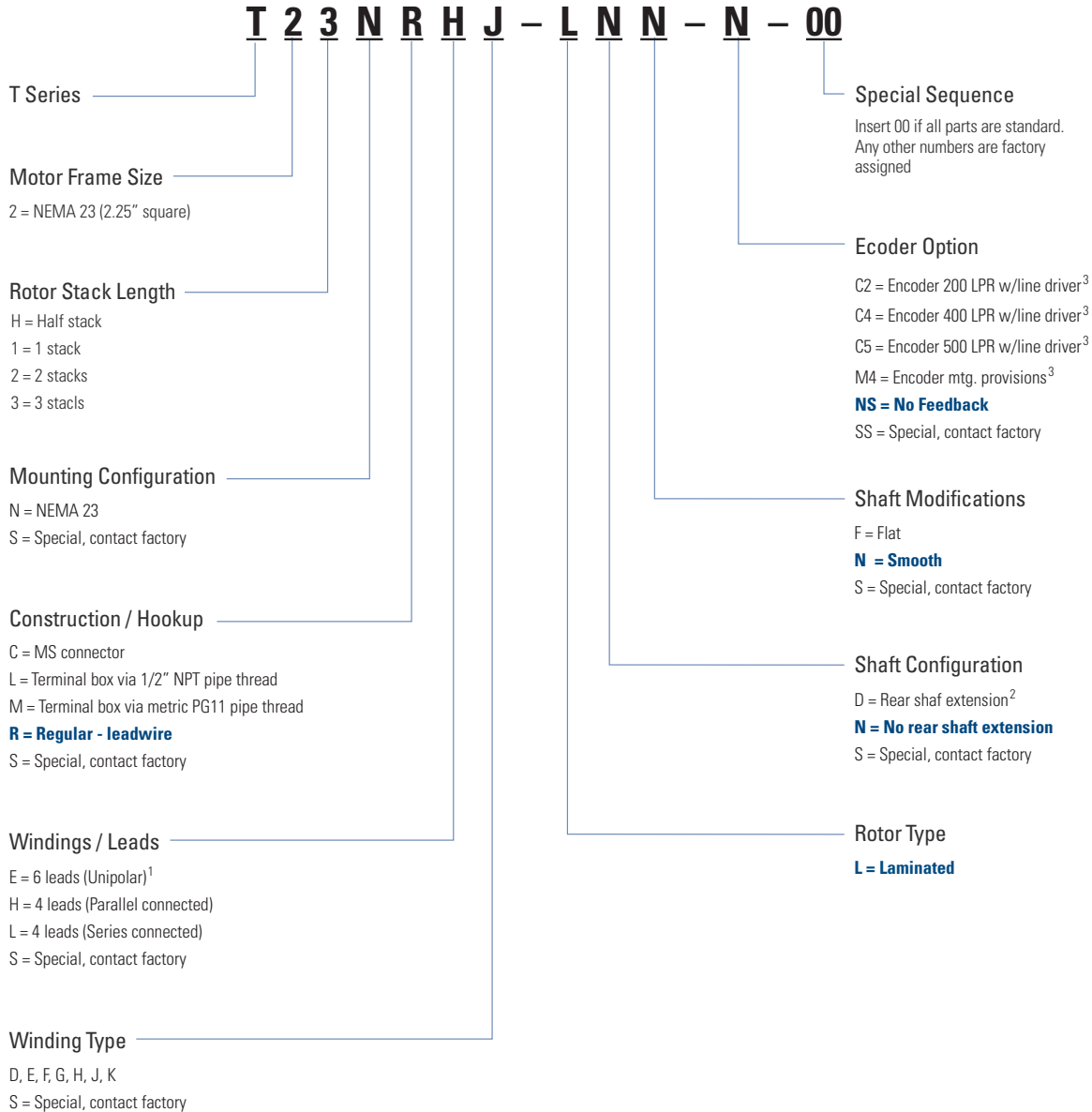

Notes:

1. N/A with "C" Construction / Hookup option
2. "R" Construction / Hookup only, required for motors with encoders
3. Requires "R" Construction / Hookup option and "D" Shaft Configuration option

M & P Series Stepper Motor

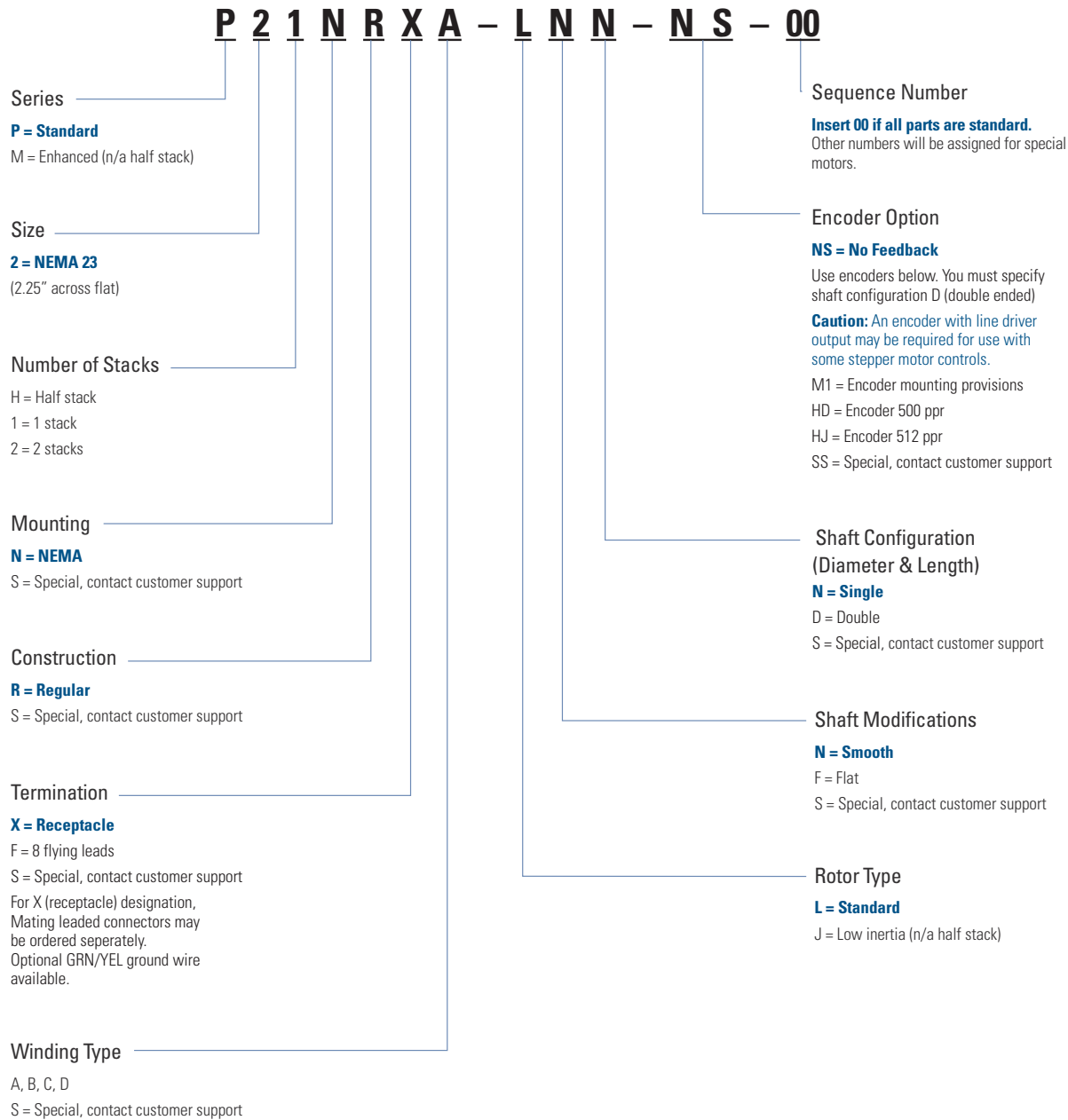

Note: Options shown in bold blue text are considered standard.

Model Nomenclature

NEMA 34 K & N Series Stepper Motor

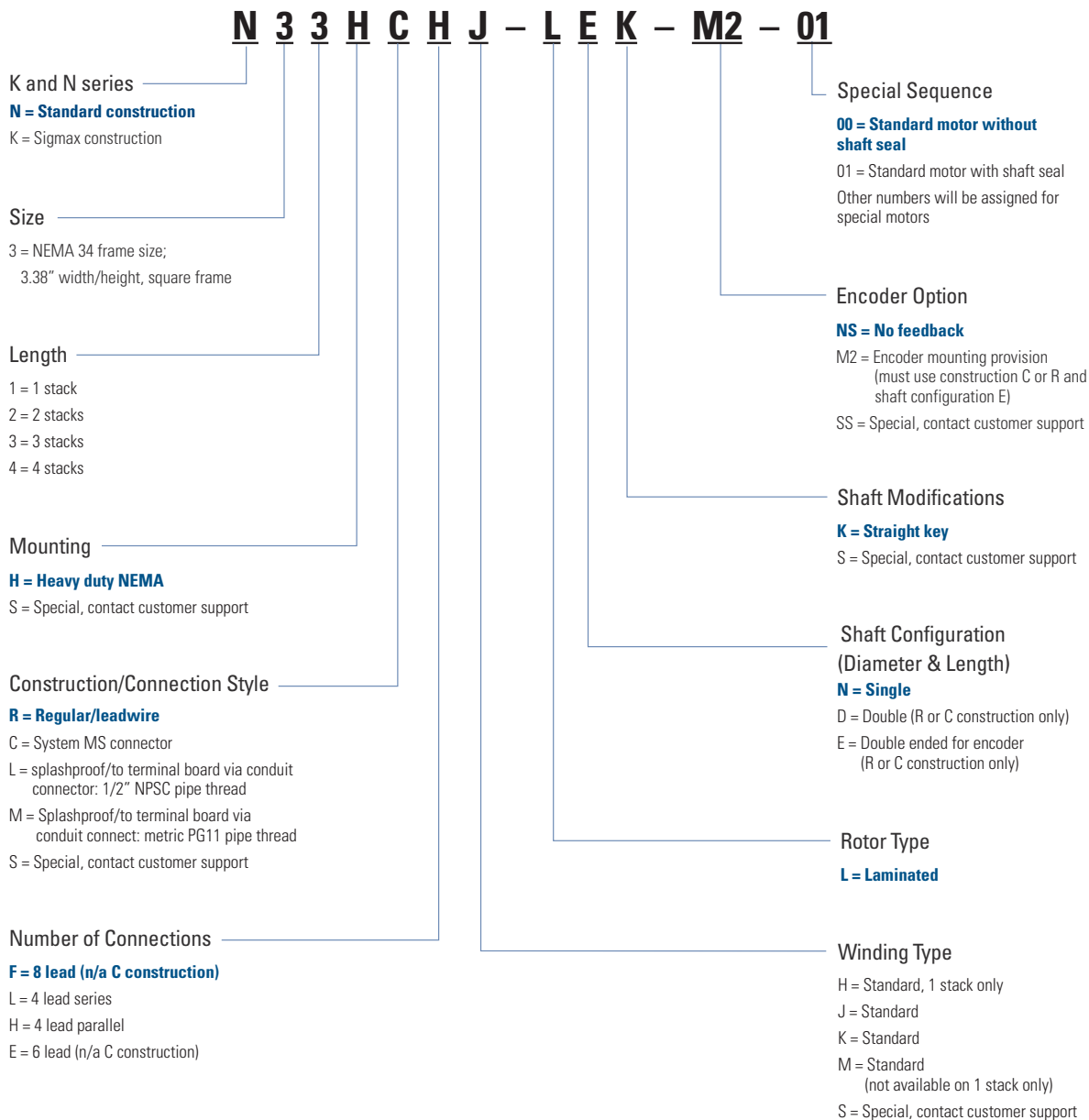

Note: Options shown in bold blue text are considered standard.

NEMA 42 K & N Series Stepper Motor

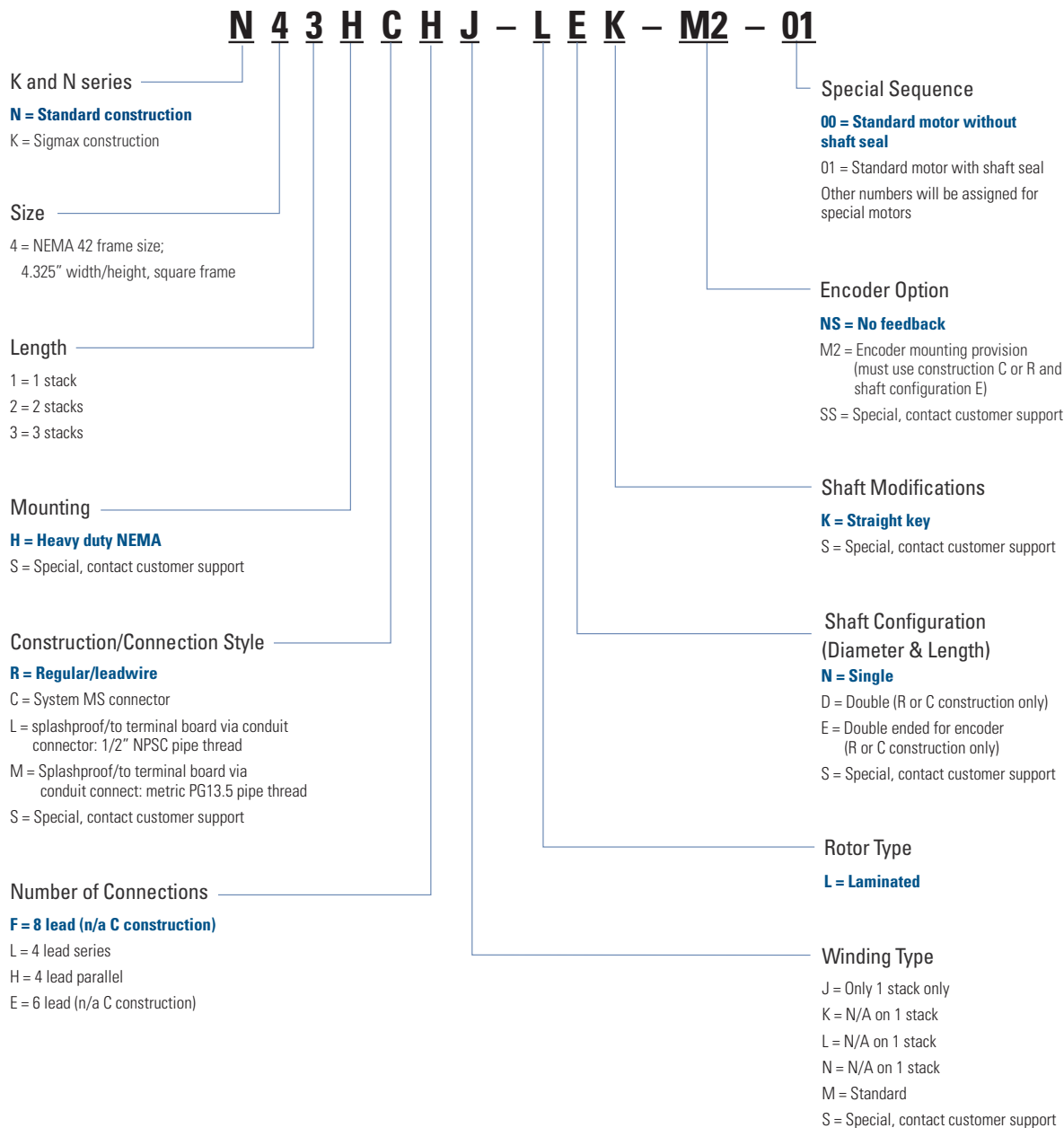

Note: Options shown in bold blue text are considered standard.

Model Nomenclature

E & H Series Stepper Motor

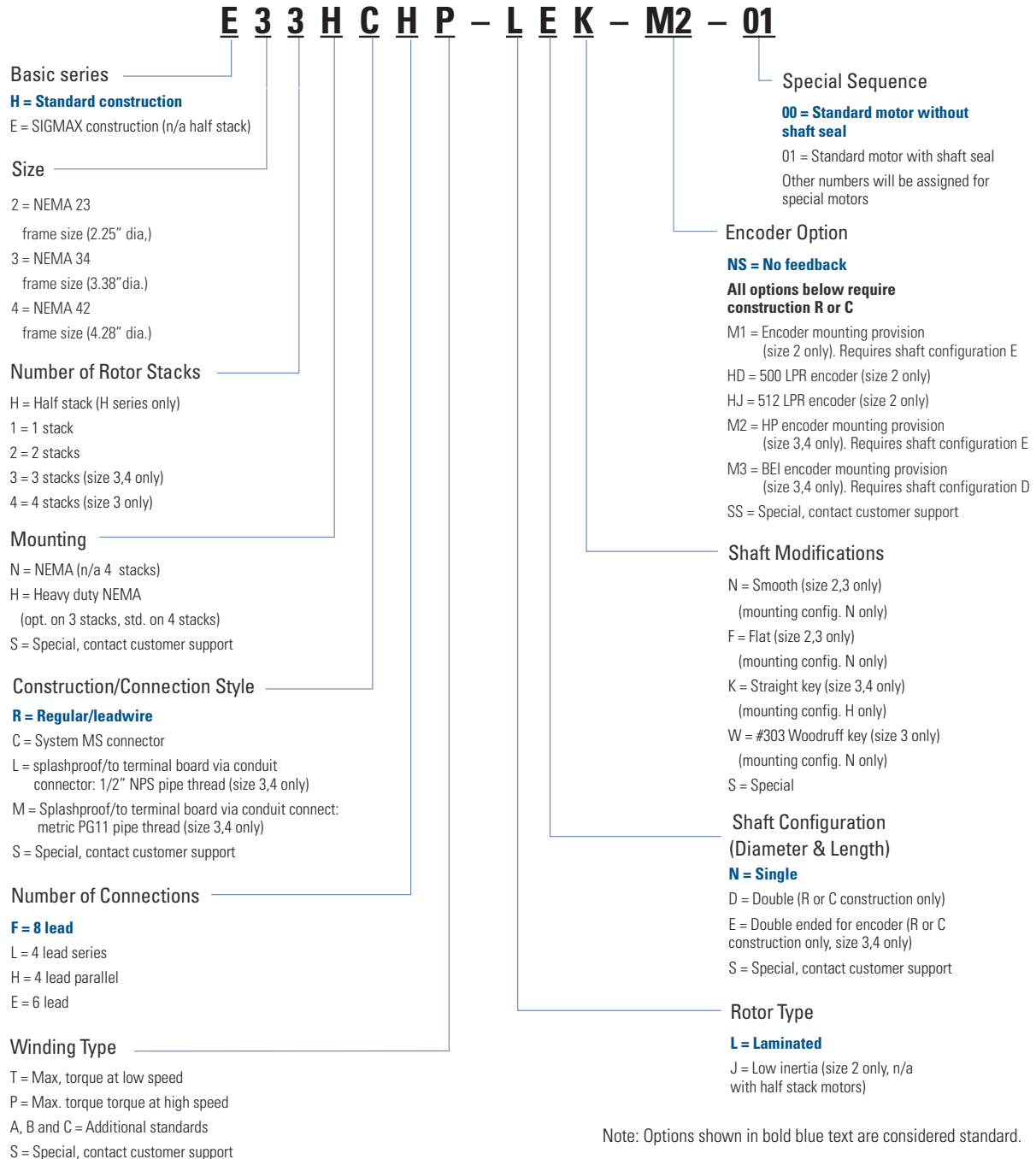

MH172 Stepper Motor

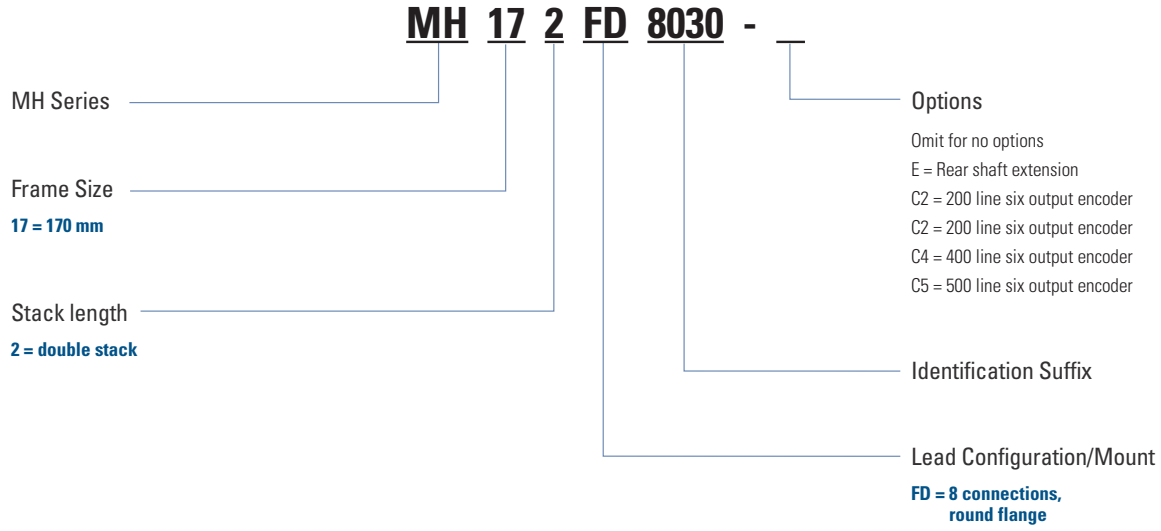

Note: Options shown in bold blue text are considered standard.

Model Nomenclature

M O D E L N O M E N C L A T U R E

MX Series Hazardous Duty Stepper Motor

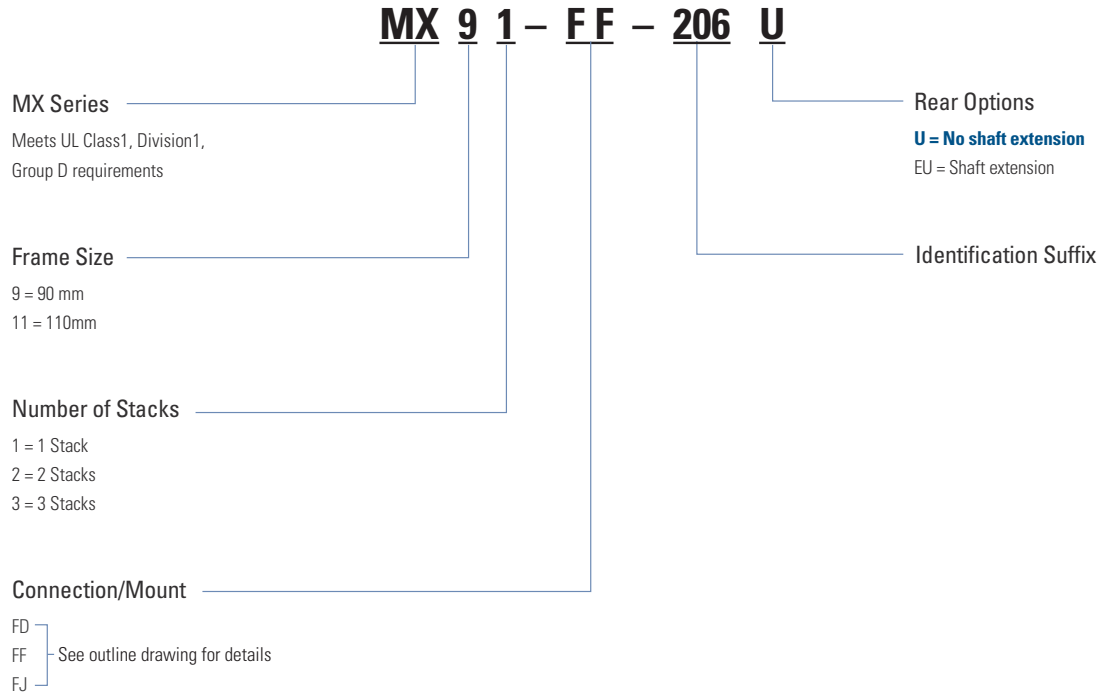

Note: Options shown in bold blue text are considered standard.

XTRUE Gearhead Series

XT 080 - 005 - 0 - RMA080 - 28

XTRUE Series

XT = XTRUE

Frame Size

- 040 = Size 40
- 060 = Size 60
- 080 = Size 80
- 120 = Size 120
- 160 = Size 160

Ratio

- 003 = 3:1
- 004 = 4:1
- 005 = 5:1
- 007 = 7:1
- 008 = 8:1
- 010 = 10:1
- 015 = 15:1
- 020 = 20:1
- 025 = 25:1
- 030 = 30:1
- 040 = 40:1
- 050 = 50:1
- 070 = 70:1
- 080 = 80:1
- 100 = 100:1

Custom Options

- 0 = None
- S = Special

RediMount™ Option

Frame Size	NEMA*	Description
060	23	RM060-1 (shaft dia. = 0.25" x 0.81")
		RM060-147 (shaft dia. = 0.3125" x 0.81")
080	34	RMA080-28 (shaft dia. = 0.5" x 1.25")
		RMA080-61 (shaft dia. = 0.625" x 1.25")
120	42	RMA115-72 (shaft dia. = 0.75" x 2.19")

* Fits standard NEMA pilot and bolt circle with through holes. Contact customer support for other RediMount options to meet your needs.

Model Nomenclature

MODEL NOMENCLATURE

KS Series AC Synchronous Motor

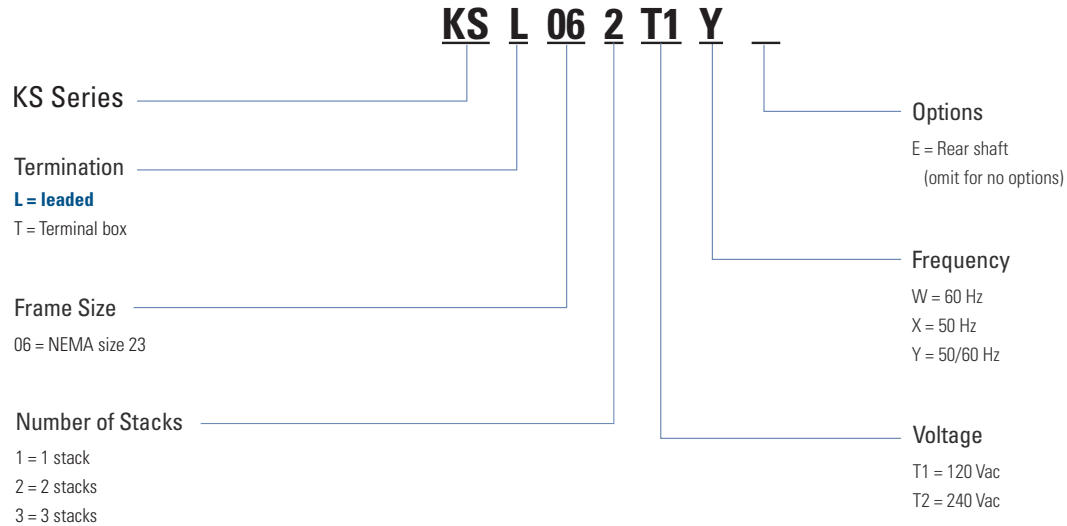

Note: Options shown in bold blue text are considered standard.

SS Series AC Synchronous Motor

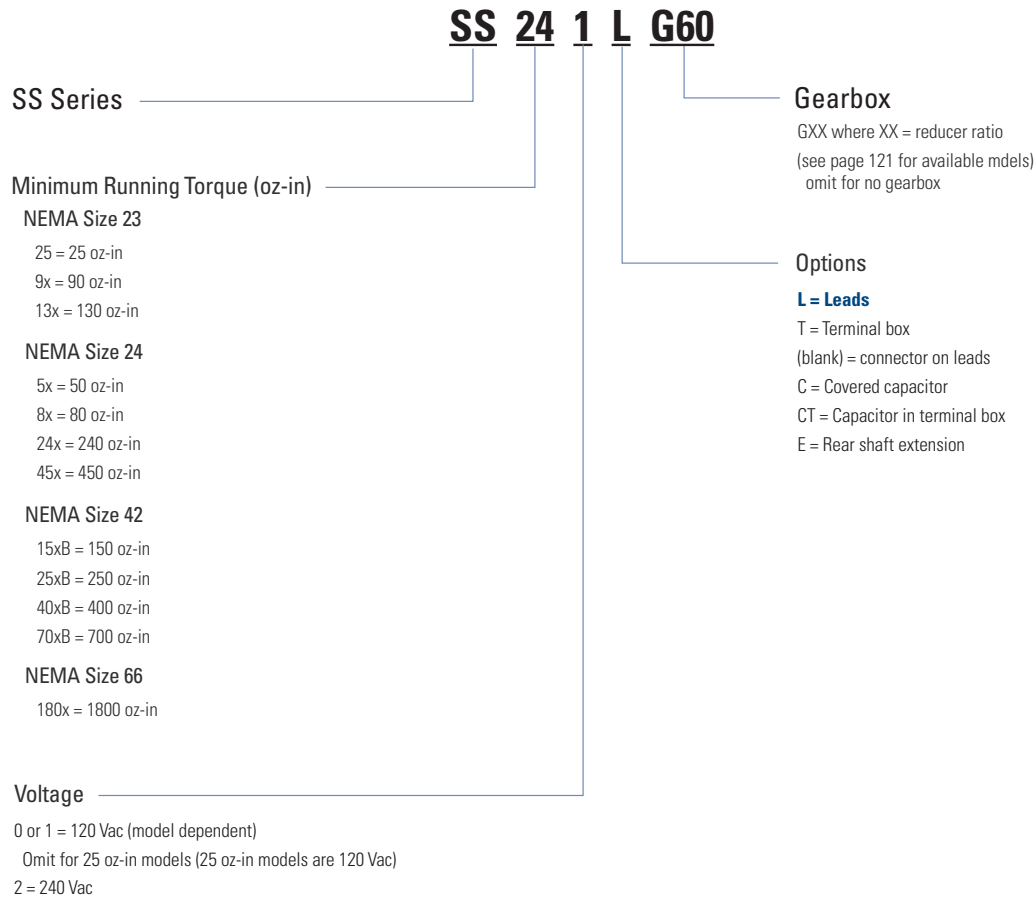

Note: Options shown in bold blue text are considered standard.

Model Nomenclature

X(CE) Series AC Synchronous Motor

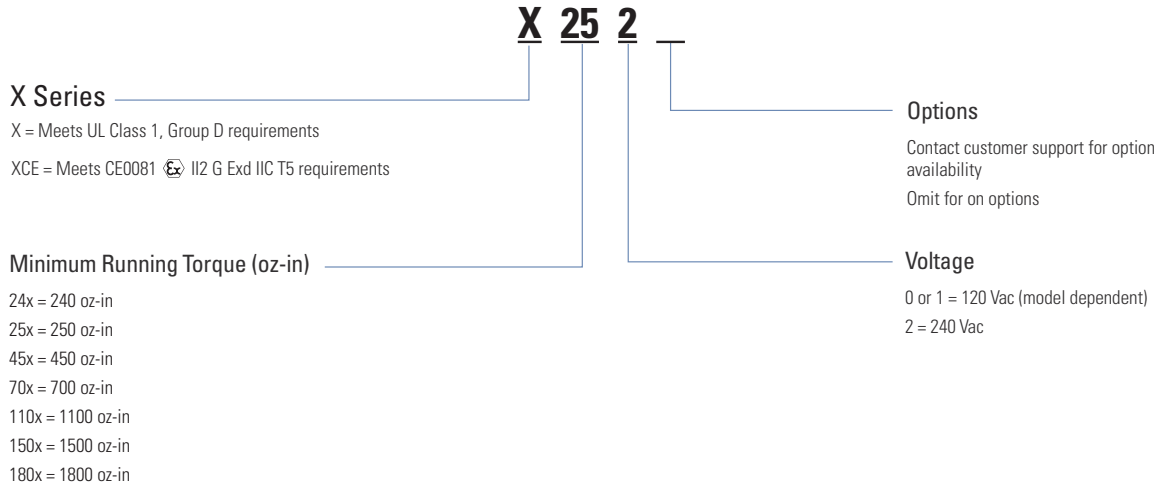

Note: Options shown in bold blue text are considered standard.

MOTIONEERING® Application Engine

To help select and size Kollmorgen components, this Windows®-based motor-sizing program takes a systems approach to the selection of brushless DC servomotors, stepper motors and drives. MOTIONEERING application engine, available at www.electromate.com uses a project concept for the collection and saving of rotary and linear multi-axis load information. This provides the user the flexibility to sum the effects of multiple axes of motion for power supply and shunt regeneration sizing.

A wide variety of linear and rotary mechanisms are provided including lead screw, rack and pinion, conveyor, nip rolls, cylinder, rotary, and direct data-entry using unique sizing algorithms and product databases criteria.

The searchable database consists of hundreds of systems on product combinations including rotary housed and frameless brushless servomotors, direct drive rotary and linear brushless servomotors, linear positioners (electric cylinders, rodless positioners, and precision tables) and stepper systems.

The MOTIONEERING application engine also provides versatile units-of-measure selection options for mechanism and motion profile data-entry, with the ability to convert data into other available units. Online Help explains program functions and the definition of terms and equations used in the program.

Features

- Group multiple mechanisms within a “project” – organize and combine data for power supply and regeneration sizing
- Types of mechanisms for analysis include lead screw, rack and pinion, conveyor, nip rolls, rotary and direct drive linear motor
- Motion profile options include simple triangle, 1/3-1/3-1/3 trapezoidal, variable traverse trapezoidal, and more
- Search results display shows color highlighted solution set of options for easy evaluation of system specifications and selection

Supported Operating Systems

- Microsoft® Windows 2000, XP, Vista

MOTIONEERING 6.2 includes

- VLM and AKD systems
- AKM8 and S700 systems
- AKM Gearmotor/AKD systems
- BH & MH/S700 systems
- Frameless DDR(F&FH)/AKD systems

Note: Performance curves included for all servomotor systems

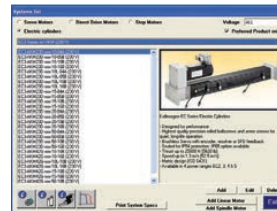
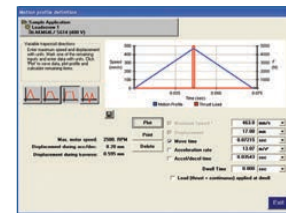
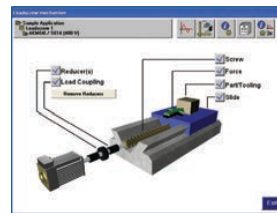

Part No.	Description	Price	Lead Time	Availability
AKM8-100-1000	AKM8-100-1000	\$1,200.00	12 Weeks	In Stock
AKM8-100-2000	AKM8-100-2000	\$1,500.00	12 Weeks	In Stock
AKM8-100-3000	AKM8-100-3000	\$1,800.00	12 Weeks	In Stock
AKM8-100-4000	AKM8-100-4000	\$2,100.00	12 Weeks	In Stock
AKM8-100-5000	AKM8-100-5000	\$2,400.00	12 Weeks	In Stock