

SYSTEM OVERVIEW

Pacific Scientific PMA & PC800/PCE800 Systems

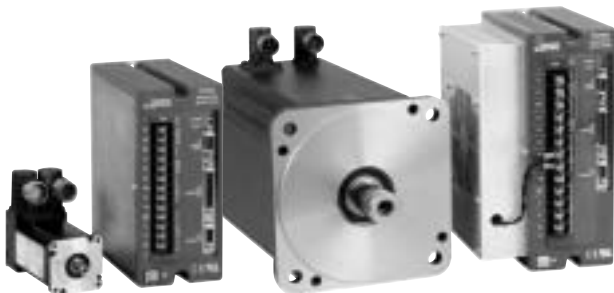

PC800/PCE800 SERIES DRIVES SEE PAGES 18-21

The PC800 and PCE800 Series are the next generation of Pacific Scientific's all-digital brushless servo drives. They provide a cost-effective, high-performance alternative to previous generation drives in a package 40% smaller than equivalent older servos.

The PC800 uses 240 VAC input power. The new PCE800 family uses 480 VAC input power for global acceptance of your machine.

These drives use a single DSP to close the current, velocity, and position loops. All system and application parameters are set in software to insure repeatability and eliminate drift. The PC800 Family is available in multiple power levels, all with integral power supplies. The drives comply with the CE low-voltage directive without requiring additional isolation.

Like all Pacific Scientific drives, the PC/PCE800 Series can accept either step and direction or analog commands. Motion profiling is standard – the PC/PCE800 Series' internal profile generator allows pre-set index moves. The PC/PCE800 Series features Pacific Scientific's patented, 24-bit DRDC (Digital Resolver to Digital Conversion) algorithm to provide the smoothest low-speed performance in its class and position accuracy as low as five arc seconds. And, its 400 Hz velocity-loop bandwidth is the highest in the industry. These features bring you the utmost in simplified drive set-up and tuning for complicated mechanical systems. Advanced tuning also allows systems to settle quickly.

Now manufacturers around the world can take advantage of SERCOS (Serial Real-time Communications System) technology with the PC/PCE840 Series digital brushless servo drives. The PC/PCE840 Series brings you the same quality, reliability and performance you've come to expect from Pacific Scientific and now it delivers the capability to utilize the enhanced digital two-way control and drive communication capabilities of SERCOS interface™.

Using the latest SERCOS816 ASIC, the PC/PCE840 Series delivers network communication rates for distributed motion control up to 16 MHz. The PC/PCE840 Series complies with IEC/EN 61491, the industry's only open control standard, assuring integration with controls or devices supporting SERCOS. Its noise-immune fiber-optic cable and ring network topology greatly reduce wiring costs, installation and set-up time, and speed tuning and troubleshooting by supporting a rich set of diagnostic capabilities.

PMA SERIES MOTORS SEE PAGE 16

The PMA Series of brushless servomotors delivers a comprehensive line of rugged, cost effective servomotors. Covering frame sizes from 55 mm square to 190 mm square and a continuous rated torque of 0.21 to 54 N-m, these motors offer an economic means to satisfy the requirements of your application. Standard IP65 sealing and the availability of IP67 washdown duty as an option on selected models allows the PMA Series to stand up to the rigors of the factory floor. Global certifications and input voltages on most models to 650 volts assure your machine's acceptance worldwide.

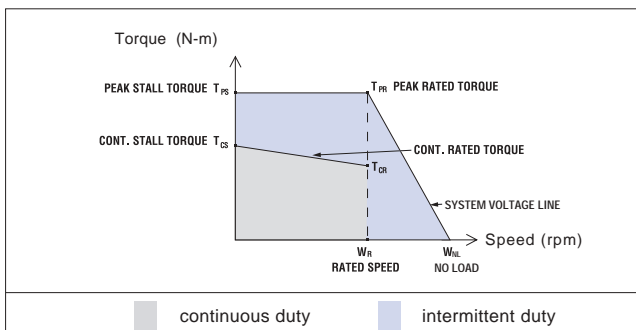

System torque/speed information on the following pages is designed to help you select the optimum brushless servo motor/controller combination.

The nominal values in this data illustrate performance for the recommended motor/controller systems.

The performance characteristics of a brushless servo system (motor/controller combination) are described by a torque/speed operating envelope. As shown above, the shaded areas of the curve indicate the continuous duty and intermittent duty zones of the system.

Continuous Duty Zone

The continuous duty zone is bordered by the maximum continuous torque line up to the rated speed of the motor. The continuous torque line is set by either the motor's maximum rated temperature, or the controller's rated continuous current output, whichever is less. The system voltage line is set by the voltage rating of the controller, the line voltage supplied, and the motor winding. The system can operate on a continuous basis anywhere within this area, assuming the motor temperature is 40°C or less, ambient. Refer to the Test Conditions on the pages that follow.

Intermittent Duty Zone

The intermittent duty zone is bordered by the peak torque line and the system voltage line. The peak torque line is set by either the controller's peak current rating, which the controller can produce for a limited time, or the maximum rated current for the motor, whichever is less. Refer to the Rating Data on the pages that follow. NOTE: higher torque levels may be achievable at higher power levels. Consult Pacific Scientific for more details. The system voltage line is set by the voltage rating of the controller, the line voltage applied and the motor winding. Operation in the intermittent zone must be limited to a duty cycle that will produce an RMS system torque falling within the continuous duty area. The RMS torque value is defined by the magnitude of the intermittent torque and the percentage of the time spent at that torque.

Zero - Peak, or RMS?

Current brushless drive technology uses a sinusoidal output. Pacific Scientific rates its systems using RMS values to accurately reflect system performance operating with a sinusoidal waveform. Older published ratings were based on 0 - peak values, using a trapezoidal waveform.

MOTIONEERING® Application Engine is the comprehensive engineering resource tool to help you size and select the appropriate servo or stepper system for your application. An intuitive interface lets you build your motion application, then find the right Danaher Motion system to fill your needs.

The **MOTIONEERING** CD-ROM also includes electronic files of detailed selection information and product literature on all the products mentioned in this catalog.

A copy of this useful engineering tool has been bound into the back inside cover of this catalog.

SYSTEM OVERVIEW

Pacific Scientific PMA & PC800/PCE800 Systems

RECOMMENDED MOTOR/DRIVE SYSTEMS, 240 VAC, 320 VDC bus ^①

Servo Motor Model ^⑤	Servo Drive Model	Peak Stall Torque T_{PS} ^② N-m (lb-in)	Peak Rated Torque T_{PR} ^② N-m (lb-in)	Cont. Stall Torque T_{CS} N-m (lb-in)	Cont. Rated Torque T_{CR} N-m (lb-in)	Rated Speed W_R ^③ rpm	No-Load Speed W_{NL} rpm	Cont. Stall Current I_{CS} A_{RMS}	Current at Peak Torque I_{PS} A_{RMS}	Inertia ^④ J $kgm^2 \times 10^{-3}$ (lb-in-S ² $\times 10^{-3}$)	Inductance Line-Line L mH
PMA Series motors with PC8xx											
PMA11A	PC8x2 ^②	1.4 (12.4)	1.4 (12.4)	0.26 (2.3)	0.22 (1.9)	6,600	12,900	0.96	5.3	0.012 (0.102)	7.1
PMA12A	PC8x2 ^②	1.7 (14.8)	1.7 (14.7)	0.6 (5.3)	0.47 (4.2)	8,500	10,800	1.88	5.3	0.019 (0.164)	4.3
PMA13B	PC8x2 ^②	1.7 (15.3)	1.7 (15.2)	0.9 (8.0)	0.6 (5.3)	9,000	10,600	2.73	5.3	0.026 (0.226)	2.7
PMA21B	PC8x2 ^②	1.8 (16.3)	1.8 (16.2)	0.63 (5.6)	0.50 (4.4)	6,050	9,250	1.72	5.3	0.022 (0.19)	10.5
PMA22B	PC8x3 ^②	4.7 (42.0)	4.7 (41.9)	1.3 (11.5)	1.1 (9.4)	4,650	7,100	2.65	10.6	0.038 (0.34)	7.4
PMA22B	PC8x2 ^②	2.6 (22.7)	2.5 (22.5)	1.3 (11.5)	1.0 (8.9)	5,750	7,100	2.65	5.3	0.038 (0.34)	7.4
PMA23B	PC8x2 ^②	3.9 (34.2)	3.9 (34.1)	2.0 (17.7)	1.6 (14.6)	3,600	4,700	2.7	5.3	0.055 (0.49)	6.8
PMA23C	PC8x3 ^②	5.9 (52.4)	5.9 (52.2)	2.0 (17.7)	1.6 (14.2)	4,200	5,850	3.4	10.6	0.055 (0.49)	10.6
PMA23D	PC8x4 ^②	7.3 (64.6)	7.3 (64.3)	2.0 (17.7)	1.4 (12.3)	6,400	8,750	5.0	20.0	0.055 (0.49)	3.0
PMA24C	PC8x3 ^②	7.9 (70.2)	7.9 (70.9)	2.6 (23.0)	2.2 (19.5)	3,000	4,350	3.3	10.6	0.072 (0.64)	8.9
PMA24D	PC8x4 ^②	9.5 (84.1)	9.5 (83.8)	2.6 (23.0)	1.9 (17.2)	4,950	6,950	5.3	21.2	0.072 (0.64)	3.5
PMA42M	PC8x2 ^②	7.7 (67.9)	7.6 (67.7)	4.1 (36.3)	3.9 (34.5)	1,600	2,350	2.8	5.3	0.36 (3.2)	26.0
PMA42N	PC8x3 ^②	11.3 (99.9)	11.2 (99.6)	4.0 (35.4)	3.8 (33.6)	1,950	3,100	3.6	10.6	0.36 (3.2)	14.3
PMA42Q	PC8x4 ^②	12.6 (111)	12.5 (111)	4.1 (36.3)	3.4 (30.1)	3,800	5,450	6.5	21.2	0.36 (3.2)	4.7
PMA43N	PC8x3 ^②	16.9 (149)	16.8 (149)	5.9 (52.2)	5.8 (51.3)	1,250	2,050	3.6	10.6	0.52 (4.6)	20.0
PMA43Q	PC8x4 ^②	17.3 (153)	17.2 (152)	6.0 (53.2)	5.2 (46.0)	3,000	4,050	7.1	21.2	0.52 (4.6)	5.3
PMA44N	PC8x3 ^②	23.3 (206)	23.2 (206)	8.2 (72.6)	7.9 (70.0)	850	1,550	3.6	10.6	0.68 (6.0)	27.0
PMA44P	PC8x3 ^②	15.9 (141)	15.9 (140)	8.0 (71.3)	7.4 (65.5)	1,750	2,250	5.3	10.6	0.68 (6.0)	12.4
PMA44Q	PC8x4 ^②	23.2 (205)	23.1 (205)	8.1 (71.6)	7.3 (64.4)	2,100	3,000	7.1	21.2	0.68 (6.0)	7.1
PMA45N	PC8x3 ^②	29.0 (256)	28.9 (256)	10.2 (90.3)	9.9 (87.6)	600	1,200	3.6	10.6	0.84 (7.4)	33.0
PMA45Q	PC8x4 ^②	29.3 (259)	29.2 (258)	10.2 (90.3)	9.4 (83.2)	1,650	2,350	7.1	21.2	0.84 (7.4)	8.7
PMA53Q	PC8x4 ^②	26.9 (238)	26.8 (237)	10.5 (92.9)	9.6 (85.0)	1,300	2,250	6.8	21.2	1.92 (17.0)	15.0
PMA54Q	PC8x4 ^②	34.1 (302)	34.1 (301)	13.5 (120)	12.4 (110)	1,200	1,800	7.1	21.2	2.49 (22.0)	16.0
PMA55Q	PC8x4 ^②	43.0 (380)	42.9 (379)	17.0 (151)	16.0 (141)	900	1,450	7.1	21.2	3.06 (27.1)	20.0

RECOMMENDED MOTOR/DRIVE SYSTEMS, 480 VAC, 640 VDC bus ^①

PMA Series motors with PCE8xx Drives											
Servo Motor Model ^⑤	Servo Drive Model	Peak Stall Torque T_{PS} ^② N-m (lb-in)	Peak Rated Torque T_{PR} ^② N-m (lb-in)	Cont. Stall Torque T_{CS} N-m (lb-in)	Cont. Rated Torque T_{CR} N-m (lb-in)	Rated Speed W_R ^③ rpm	No-Load Speed W_{NL} rpm	Cont. Stall Current I_{CS} A_{RMS}	Current at Peak Torque I_{PS} A_{RMS}	Inertia ^④ J $kgm^2 \times 10^{-3}$ (lb-in-S ² $\times 10^{-3}$)	Inductance Line-Line L mH
PMA42N	PCE8x3 ^②	8.2 (72.6)	8.1 (71.7)	4.1 (36.3)	2.8 (24.8)	5,500	6,250	3.7	7.5	0.36 (3.2)	14.3
PMA43Q	PCE8x3 ^②	12.2 (108)	12.1 (107)	6.1 (54.0)	5.1 (45.1)	3,350	4,150	3.7	7.5	0.52 (4.6)	20.0
PMA43Q	PCE8x5 ^②	18.2 (161)	18.1 (160)	6.1 (54.0)	3.8 (33.6)	6,450	8,100	7.2	22.5	0.52 (4.6)	5.3
PMA44N	PCE8x3 ^②	16.9 (150)	16.8 (149)	8.2 (72.6)	7.2 (63.7)	2,400	3,050	3.6	7.5	0.68 (6.0)	27.0
PMA44Q	PCE8x5 ^②	24.4 (216)	24.3 (215)	8.2 (72.6)	4.7 (41.6)	4,700	6,000	7.2	22.5	0.68 (6.0)	7.1
PMA45N	PCE8x3 ^②	21.0 (186)	20.9 (185)	10.2 (90.3)	9.3 (82.3)	1,900	2,450	3.6	7.5	0.84 (7.4)	33.0
PMA45Q	PCE8x5 ^②	30.8 (273)	30.7 (272)	10.2 (90.3)	7.6 (67.3)	3,700	4,750	7.1	22.5	0.84 (7.4)	8.7
PMA53Q	PCE8x5 ^②	27.9 (247)	27.8 (246)	10.5 (92.9)	8.2 (72.6)	2,900	4,450	6.8	22.5	1.92 (17.0)	15.0
PMA53R	PCE8x5 ^{②⑥}	21.6 (191)	21.5 (190)	10.5 (92.9)	6.8 (60.2)	4,750	6,400	9.7	22.5	1.92 (17.0)	7.2
PMA54Q	PCE8x5 ^②	35.6 (315)	35.5 (314)	13.5 (120)	11.3 (100)	2,500	3,650	7.1	22.5	2.49 (22.0)	16.0
PMA54R	PCE8x5 ^{②⑥}	26.0 (230)	25.8 (228)	13.5 (120)	9.7 (85.9)	4,300	5,450	10.6	22.5	2.49 (22.0)	7.1
PMA55Q	PCE8x5 ^②	44.8 (397)	44.7 (396)	17.0 (151)	19.0 (130)	2,000	2,900	7.1	22.5	3.06 (27.1)	20.0
PMA55R	PCE8x5 ^{②⑥}	32.8 (290)	32.6 (289)	17.0 (151)	13.3 (109)	3,400	4,300	10.6	22.5	3.06 (27.1)	8.8
PMA57R	PCE8x5 ^{②⑥}	45.9 (406)	45.7 (404)	22.0 (195)	18.6 (165)	2,400	3,050	9.8	22.5	4.21 (37.3)	12.5
PMA65R	PCE8x5 ^{②⑥}	55.9 (495)	55.7 (493)	30.0 (266)	24.0 (212)	1,900	2,600	11.3	22.5	7.9 (70.0)	20.0
PMA66R	PCE8x5 ^{②⑥}	67.1 (594)	66.9 (592)	36.0 (319)	30.5 (270)	1,600	2,150	11.3	22.5	9.4 (83.3)	24.0

① See page 17 for definitions of ratings.

② Peak torque ratings are for 5 seconds.

③ Rated speed is provided for operation on 480 VAC 3-phase line.

④ Includes resolver feedback inertia.

⑤ Each system requires one feedback and one motor power cable.

⑥ Optional fan kit required to achieve continuous torque ratings.

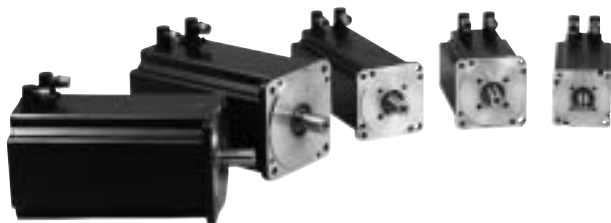

Features

Benefits

PMA Series Motors

Rugged Brushless Construction
Eliminates brush replacement maintenance. Stands up to the rigors of the factory floor

High torque over wide speed range
Improved machine throughput

Anti-cog motor design
Smooth low-speed operation

IP65 TENV construction standard
Withstands rigorous environments

IP67 protection on selected PMA models
Withstands washdown

Class H insulation
Longer life for reduced machine downtime

Overtemperature thermistor
Protection against motor damage

Multiple feedback options
Allows numerous control methods

Brake option
Improved machine safety

Neodymium-iron-boron magnets
Maximum performance, maximum value

High quality Interconnectron connectors
Faster installation and maintenance

High voltage models available
Improved application flexibility

Global approvals and agency recognition
Eases recognition process for a machine

Two year warranty
Quality and reliability for reduced machine downtime

PMA1 SERIES MOTOR

mm (in)

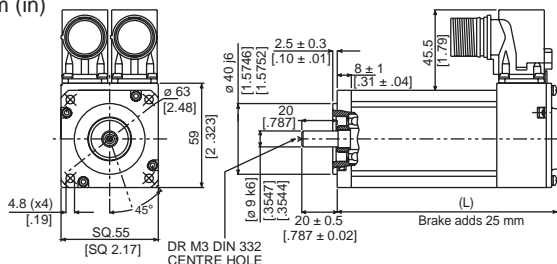

Motor	PMA13	PMA12	PMA11
L	175 (6.89)	150 (5.906)	125 (4.921)

Sold & Serviced By:
ELECTROMATE
Toll Free Phone (877) SERV098
Toll Free Fax (877) SERV099
www.electromate.com
sales@electromate.com

PMA2 SERIES MOTOR

mm (in)

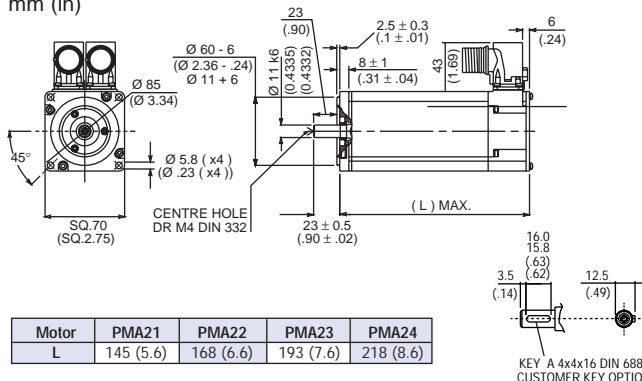

Motor	PMA21	PMA22	PMA23	PMA24
L	145 (5.6)	168 (6.6)	193 (7.6)	218 (8.6)

PMA4 SERIES MOTOR

mm (in)

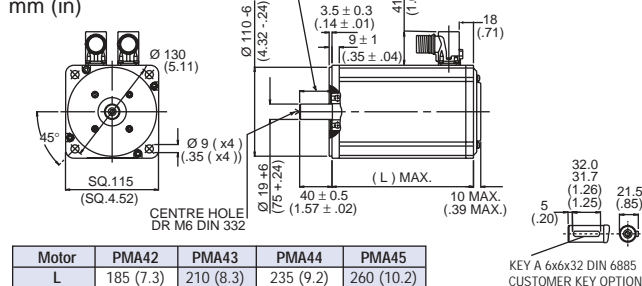

Motor	PMA42	PMA43	PMA44	PMA45
L	185 (7.3)	210 (8.3)	235 (9.2)	260 (10.2)

PMA5 SERIES MOTOR

mm (in)

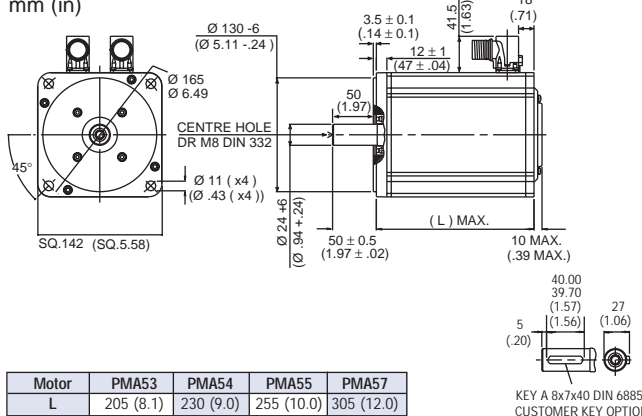

Motor	PMA53	PMA54	PMA55	PMA57
L	205 (8.1)	230 (9.0)	255 (10.0)	305 (12.0)

PMA6 SERIES MOTOR

mm (in)

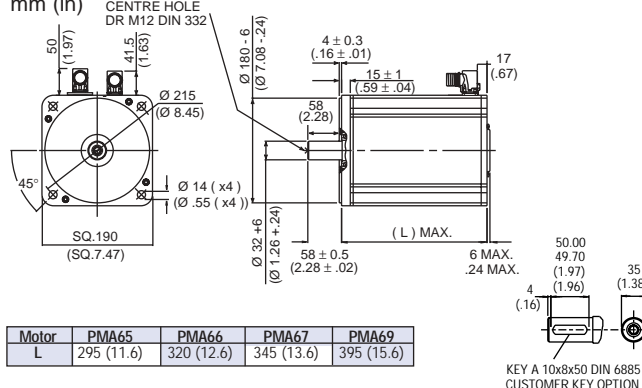

Motor	PMA65	PMA66	PMA67	PMA69
L	295 (11.6)	320 (12.6)	345 (13.6)	395 (15.6)

KEY A 10x8x50 DIN 6885 CUSTOMER KEY OPTION

RATINGS AND CHARACTERISTICS

Motor parameters and winding data. See system data beginning on page 15 for typical torque/speed performance.

PMA1-2 SERIES MOTORS	PARAMETER	SYMBOL	UNITS	PMA11	PMA12	PMA13	PMA21	PMA22	PMA23	PMA24	
	Continuous stall torque ① ②	T _{CS}	N-m (lb-in)	0.26 (2.3)	0.6 (5.3)	0.9 (8.0)	0.63 (5.6)	1.3 (11.5)	2 (17.7)	2.6 (23.0)	
	Peak torque ③ ④	T _{PK}	N-m (lb-in)	1.4 (12.4)	2.9 (25.6)	4.3 (38.0)	2.3 (20.4)	4.7 (41.6)	7.2 (63.7)	9.6 (85.0)	
	Inertia ⑤ ⑥	J _M	kgm ² x10 ⁻³ (lb-in-sec ² x10 ⁻³)	0.012 (0.102)	0.019 (0.164)	0.026 (0.226)	0.022 (0.19)	0.038 (0.34)	0.055 (0.49)	0.072 (0.64)	
	Static friction (max.)	T _f	N-m (lb-in)	0.008 (0.071)	0.012 (0.106)	0.018 (0.160)	0.016 (0.14)	0.033 (0.29)	0.050 (0.44)	0.065 (0.58)	
	Viscous damping coefficient	K _{DV}	N-m/krpm (lb-in/krpm)	0.001 (0.009)	0.002 (0.018)	0.003 (0.027)	0.003 (0.03)	0.006 (0.05)	0.009 (0.08)	0.012 (0.11)	
	Thermal resistance	R _{TH}	deg. C/watt	3.1	2.0	1.6	1.83	1.41	1.13	0.89	
	Thermal time constant	t _{TH}	min	10.0	13.0	16.0	13.0	15.0	18.0	20.0	
	Weight (motor only)	W	kg (lbs)	1.2 (2.6)	1.5 (3.3)	1.9 (4.2)	1.7 (3.7)	2.3 (5.0)	2.9 (6.4)	3.5 (7.7)	
	WINDING DATA										
Torque constant (RMS)	K _r	N-m/A _{RMS} (lb-in/A _{RMS})	0.27 (2.38)	0.32 (2.85)	0.33 (2.90)	0.37 (3.3)	0.49 (4.3)	0.74 (6.5)-0.4 (3.5)	0.79 (7.0)-0.5 (4.1)		
Voltage constant (RMS) (I-I)	K _E	V _{RMS} /rad/sec (V _{RMS} /krpm)	0.16 (17.2)	0.20 (20.6)	0.20 (21.0)	0.23 (24.0)	0.30 (31.2)	0.45 (47.4)-0.24 (25.4)	0.49 (50.9)-0.31 (31.9)		
Continuous stall current ① ②	I _{CS}	A _{RMS}	0.96	1.88	2.73	1.72	2.65	2.7-5.0	3.3-5.3		
Current at peak torque ④	I _{PK}	A _{RMS}	5.3	9.4	13.8	6.88	10.6	10.8-20.0	13.2-21.2		
Resistance (line-to-line)	R _C	ohms	16.3	6.8	3.9	8.8	4.81	6.1-1.7	4.6-1.9		
Inductance (line-to-line)	L	mH	7.1	4.3	2.7	10.5	7.4	10.6-3.0	8.9-3.5		
Typical Rated Speed @ 240 VAC, 320 VDC bus	W _R	rpm	6,600	8,500	9,000	6,050	4,650	3,600-6,400	3,000-4,950		
Typical Rated Torque @ 240 VAC, 320 VDC bus	T _{CR}	N-m (lb-in)	0.22 (1.9)	0.48 (4.2)	0.60 (5.3)	0.5 (4.4)	1.06 (9.4)	1.7 (14.6)-1.4 (12.4)	2.2 (19.5)-2.2 (19.5)		
PMA4-5 SERIES MOTORS	PARAMETER	SYMBOL	UNITS	PMA42	PMA43	PMA44	PMA45	PMA53	PMA54		
	Cont. stall torque① ②	T _{CS}	N-m (lb-in)	4.1 (36.3)	6.1 (54.0)	8.2 (72.6)	10.2 (90.3)	10.5 (92.9)	13.5 (120)		
	Peak torque ③ ④	T _{PK}	N-m (lb-in)	14.6 (129)	21.7 (192)	29.4 (260)	36.8 (326)	31.0 (274)	41.0 (363)		
	Inertia ⑤ ⑥	J _M	kgm ² x10 ⁻³ (lb-in-sec ² x10 ⁻³)	0.36 (3.2)	0.52 (4.6)	0.68 (6.0)	0.84 (7.4)	1.92 (17)	2.49 (22)		
	Static friction (max.)	T _f	N-m (lb-in)	0.11 (1.0)	0.15 (1.3)	0.21 (1.9)	0.26 (2.3)	0.26 (2.3)	0.34 (3.0)		
	Viscous damping coefficient	K _{DV}	N-m/krpm (lb-in/krpm)	0.03 (0.27)	0.05 (0.44)	0.06 (0.53)	0.08 (0.71)	0.08 (0.71)	0.11 (0.97)		
	Thermal resistance	R _{TH}	deg. C/watt	0.68	0.59	0.51	0.45	0.55	0.53		
	Thermal time constant	t _{TH}	min	25.0	30.0	35.0	40.0	35.0	40.0		
	Weight (motor only)	W	kg (lbs)	6.2 (13.6)	7.6 (16.7)	9.0 (20.0)	10.4 (22.9)	11 (24.2)	13.0 (28.6)		
	WINDING DATA										
	Torque constant (RMS)	K _r	N-m/A _{RMS} (lb-in/A _{RMS})	1.48 (13.1)-1.11 (9.8) 0.87 (7.7)-0.63 (5.6)	1.67 (14.8)-1.34 (11.9) 0.85 (7.5)-.61 (5.4)	2.26 (20.0)-1.34 (11.9) 1.15 (10.2)-0.82 (7.3)	2.85 (25.2)-1.46 (12.9) 1.04 (9.2)	1.55 (13.7)-1.08 (9.6)	1.9 (16.8)-1.27 (11.3)		
	Voltage constant (RMS) (I-I)	K _E	V _{RMS} /rad/sec (V _{RMS} /krpm)	0.91 (94.8)-0.68 (7.1) 0.53 (55.8)-0.39 (40.6)	1.02 (107)-0.82 (86.1) 0.52 (54.9)-0.37 (39.2)	1.38 (145)-0.94 (98.8) 0.71 (74)-0.5 (52.8)	1.74 (183)-0.89 (93.4) 0.64 (66.7)	0.95 (99.3)-0.66 (69.2)	1.16 (122)-0.78 (81.5)		
	Cont. stall current ① ②	I _{CS}	A _{RMS}	2.8-3.7-4.7-6.5	3.7-4.6-7.2-10.1	3.6-5.4-7.2-10.1	3.6-7.1-10.0	6.8-9.7	7.1-10.6		
	Current at peak torque ④	I _{PK}	A _{RMS}	11.2-14.8-18.8-26.0	14.8-18.4-28.8-40.4	14.4-21.6-28.8-40.4	14.4-28.4-40.0	27.2-38.8	28.4-42.4		
	Resistance (line to line)	R _C	ohms	9.0-5.1-3.2-1.65	6.0-3.9-1.54-0.79	7.1-3.3-1.8-0.92	8.2-2.1-1.1	1.9-0.92	1.8-0.8		
Inductance (line to line)	L	mH	26.0-14.3-8.9-4.7	20.0-13.0-5.3-2.7	27.0-12.4-7.1-3.6	33.0-8.7-4.4	15.0-7.2	16.0-7.1			
Typical Rated Speed @ 240 VAC, 320 VDC bus	W _R	rpm	1,600-1,950 2,950-3,800	1,250-1,850 3,000-4,700	850-1,750 2,100-3,450	600-1,650 2,700	1,300-2,350	1,200-2,100			
Typical Rated Torque @ 240 VAC, 320 VDC bus	T _{CR}	N-m (lb-in)	3.9 (34.5)-3.8 (33.6) 3.6 (31.9)-34.0 (30.1)	5.8 (51.3)-5.6 (49.6) 5.2 (46.0)-4.5 (39.8)	7.9 (70.0)-7.5 (66.4) 7.3 (64.4)-6.7 (59.3)	9.9 (87.6)-9.4 (83.2) 8.9 (78.8)	9.6 (85.0)-8.8 (77.9)	12.4 (110)-11.6 (102.7)			
PMA5-6 SERIES MOTORS	PARAMETER	SYMBOL	UNITS	PMA55	PMA57	PMA65	PMA66	PMA67	PMA69		
	Cont. stall torque ① ②	T _{CS}	N-m (lb-in)	17.0 (151)	22.0 (195)	30.0 (266)	36.0 (319)	42.0 (372)	54.0 (478)		
	Peak torque ③ ④	T _{PK}	N-m (lb-in)	51.5 (456)	69.0 (611)	95.0 (841)	114 (1009)	133 (1177)	170 (1505)		
	Inertia ⑤ ⑥	J _M	kgm ² x10 ⁻³ (lb-in-sec ² x10 ⁻³)	3.06 (27.1)	4.21 (37.3)	7.90 (70.0)	9.40 (83.3)	10.9 (96.5)	13.9 (123)		
	Static friction (max.)	T _f	N-m (lb-in)	0.43 (3.8)	0.57 (5.0)	0.75 (6.60)	0.90 (8.0)	1.05 (9.30)	1.35 (11.9)		
	Viscous damping coefficient	K _{DV}	N-m/krpm (lb-in/krpm)	0.14 (1.24)	0.18 (1.59)	0.25 (2.20)	0.30 (2.70)	0.35 (3.10)	0.45 (4.0)		
	Thermal resistance	R _{TH}	deg. C/watt	0.47	0.45	0.38	0.35	0.32	0.28		
	Thermal time constant	t _{TH}	min	45.0	55.0	40.0	45.0	50.0	60.0		
	Weight (motor only)	W	kg (lbs)	15.0 (33.0)	19.0 (41.9)	31.0 (68.3)	36.0 (79.3)	42.0 (92.5)	54.0 (119)		
	WINDING DATA										
	Torque constant (RMS)	K _r	N-m/A _{RMS} (lb-in/A _{RMS})	2.4 (21.3)-0.8 (7.1) 0.8 (7.1)	2.26 (20)-1.13 (10)	2.66 (23.5)-1.44 (12.7)	3.21 (28.5)-1.74 (15.4)	2.04 (18.0)	2.63 (23.3)		
	Voltage constant (RMS) (I-I)	K _E	V _{RMS} /rad/sec (V _{RMS} /krpm)	1.47 (154)-0.98 (103) 0.49 (51.3)	1.38 (145)-0.69 (72.5)	1.63 (171)-0.88 (92.3)	1.96 (206)-1.06 (112)	1.25 (131)	1.61 (169)		
	Continuous stall current ① ②	I _{CS}	A _{RMS}	7.1-10.6-21.3	9.8-19.5	11.3-20.9	11.3-20.7	20.7	20.6		
	Current at peak torque ④	I _{PK}	A _{RMS}	28.4-42.4-85.2	39.2-78.0	45.2-83.6	45.2-82.8	82.8	82.4		
	Resistance (line-to-line)	R _C	ohms	2.1-0.9-0.2	1.1-0.3	0.97-0.29	1.06-0.32	0.35	0.41		
Inductance (line-to-line)	L	mH	20.0-8.8-2.2	12.5-3.1	20.0-5.90	24.0-7.0	8.2	10.4			
Typical Rated Speed @ 240 VAC, 320 VDC bus	W _R	rpm	900-1,650-3,450	1,150-2,450	N/A-1,750	N/A-1,450	1,250	950			
Typical Rated Torque @ 240 VAC, 320 VDC bus	T _{CR}	N-m (lb-in)	16.0 (142)-15.2 (134.5) 3.1 (115.9)	20.5 (181.4)-18.4 (162.9)	N/A-24.5 (216.8)	N/A-31.0 (274)	37.0 (327)	48.5 (429)			

Note: All values at 25°C unless otherwise noted. **①** Motor operated at rated winding temperature. **②** Motor operated at 25°C ambient. Ratings result of average rating between free air and cold plate mounting. Equivalent to mounting to a 10" x 10" x 1/4" aluminum heat sink. **③** Theoretical motor maximum. **④** Caution: For peak torques or peak currents greater than 4x the continuous rating, consult the factory for thermal considerations. **⑤** Add parking brake, if applicable, for total inertia from product selection data. See CD-ROM. **⑥** Motor with resolver feedback.

www.electromate.com
sales@electromate.com

PC800 DRIVES

Pacific Scientific PMA & PC800/PCE800 Systems



PC800 SERIES PERFORMANCE FEATURES

- 240 VAC nominal input power
- 2.7, 3.6 and 7.1 A_{RMS} continuous
- 5.3, 10.6 and 21.2 A_{RMS} peak output current
- Standard analog and digital interfaces
 - Step/Direction Digital interface-position or velocity control
 - Preset moves using an internal profile generator
 - ±10 V Analog interface-velocity or torque control
 - Quadrature encoder digital interface-electronic gearing follower
- All digital DSP-based RS-232/485 serial interface allows programming with an IBM-compatible PC
- Simple ASCII Protocol (SAP) compatible with many operator interfaces
- SERCOS interface™ connectivity offers communications via fiber optic network at up to 16 MHz
- Windows®-based 800Tools configuration software simplifies set-up:
 - Digital oscilloscope feature quickly shows drive function graphically
 - Intuitive parameter configuration-up and running in minutes
 - Advanced digital tuning for reduced settling time
 - All system and application parameters are set and saved
 - Automated diagnostic routine reduces troubleshooting time
- Rugged, PLC-like digital and analog I/O maximize application flexibility:
 - Six optically-isolated inputs
 - Three optically-isolated outputs
 - One relay output, 30 VDC @ 1A
 - Differential ±10 V analog input
 - Single-end analog input, ±5 VDC
 - Two analog outputs, ±5 VDC
 - Encoder quadrature output-up to 16,384 ppr
 - Encoder quadrature input (Step/Direction)
 - Enable input
 - +5 VDC @ 200 mA user output
 - +24 VDC @ 100 mA power supply for optically-isolated inputs
- Single resolver feedback survives hostile environments
- Hall/Encoder feedback allows application flexibility, making it suitable for use with many popular linear motors
- All connections on front-easy access to clearly marked connectors
- Optional Terminal Block Adapter speeds connections even further
- Separate logic supply input keeps logic power working when bus power is disconnected
- Extensive protection circuits and diagnostics to ease set-up
- 400 Hz velocity loop bandwidth
- Inaudible, high frequency, Digital PWM sine wave current control
- IGBT Power stage- more efficient, less audible noise

AGENCY APPROVAL

- UL recognized
 - 508C (Type R)
 - file #E137798
- cUL approved
- Meets IEC Vibration Standard, #68-2-6
- Models CE Compliant: EMC standard EN61800-3 and safety standard EN50178

AMPLIFIER RATINGS

	PC8x2		PC8x3		PC8x4	
Input Voltage						
Control logic voltage	90 - 264 VAC, 47 - 63 Hz, single phase					
Bus voltage	90 - 264 VAC, 1 or 3-phase					
Input Current						
Control logic current	500 mA maximum @120 VAC, 250 mA maximum @240 VAC					
	PC8x2		PC8x3		PC8x4	
	A _{RMS}	Equivalent A _{0-PEAK}	A _{RMS}	Equivalent A _{0-PEAK}	A _{RMS}	Equivalent A _{0-PEAK}
Bus Current (A)	4.5	6.4	9.0	12.7	18.0	25.5
Peak Output Current (A)						
5 seconds	5.3	7.5	10.6	15	21.2	30.0
Continuous Output Current						
25 - 40°C convection cooling (A)	2.7	0.8	3.6	5.0	7.1	10.0
25 - 40°C forced air cooling (A)	N/A	N/A	5.3	7.5	10.6	15.0
Peak Output Power @240 VAC						
1 second (kW)	2.25		4.5		9.0	
Continuous Output Power @240 VAC three phase						
25 - 40°C convection cooling (kW)	1.1		1.5		3.0	
25 - 40°C forced air cooling (kW)	N/A		2.2		4.5	
@240 VAC single phase						
25 - 40°C convection cooling (kW)	1.1		1.1		2.0	
25 - 40°C forced air cooling (kW)	N/A		1.6		2.0	
Power Stage Efficiency @ P _{CONT} (%)	98		98		98	
Shunt Regulator Power						
Peak power (300 msec) (kW)	12.8		12.8		12.8	
Continuous power						
25°C convection cooling (W)	200		200		200	
Maximum external regen duty cycle (%)	6		6		6	
Bus capacitance energy absorption from 320 V nominal bus (240 VAC) (joules)	20		30		40	



MOTIONEERING® CD-ROM

For more detailed product and selection information, see the **MOTIONEERING** CD-ROM inside the back cover of this catalog or visit our website at www.DanaherMotion.com.

PC800 DRIVES

Pacific Scientific PMA & PC800/PCE800 Systems

PC800 SERIES mm [in]

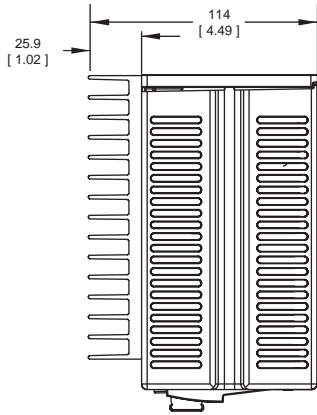

REGENERATION RESISTOR

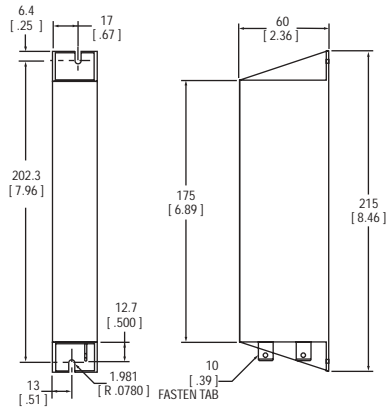

FAN KIT OPTION shown without electrical connection cable.

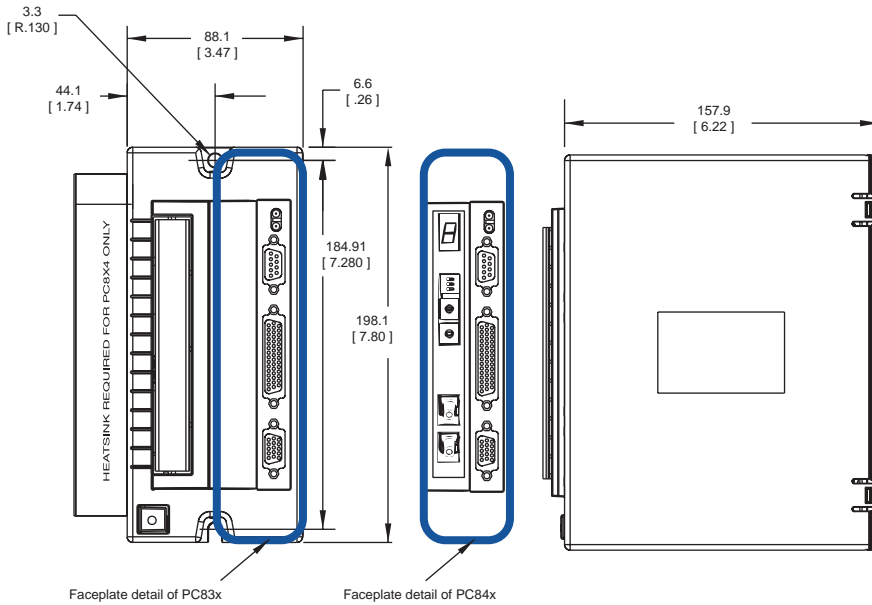
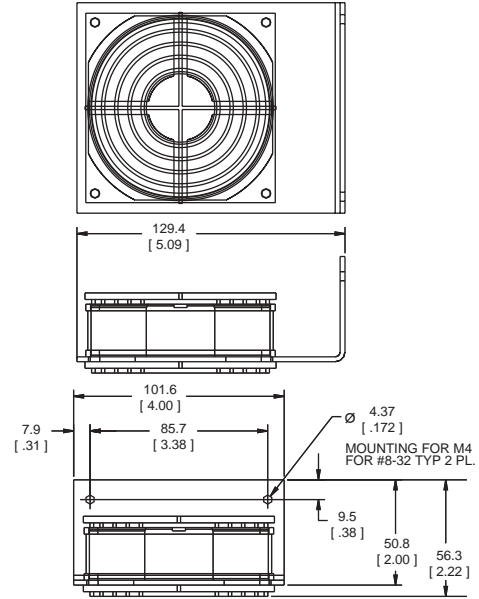

TERMINAL BLOCK ADAPTOR mm [in]

