

POWERSYNC™

NEMA 34 & 42 Frame (3.38" & 4.325" Square)

MODEL NUMBER CODE - NEMA 34 FRAME

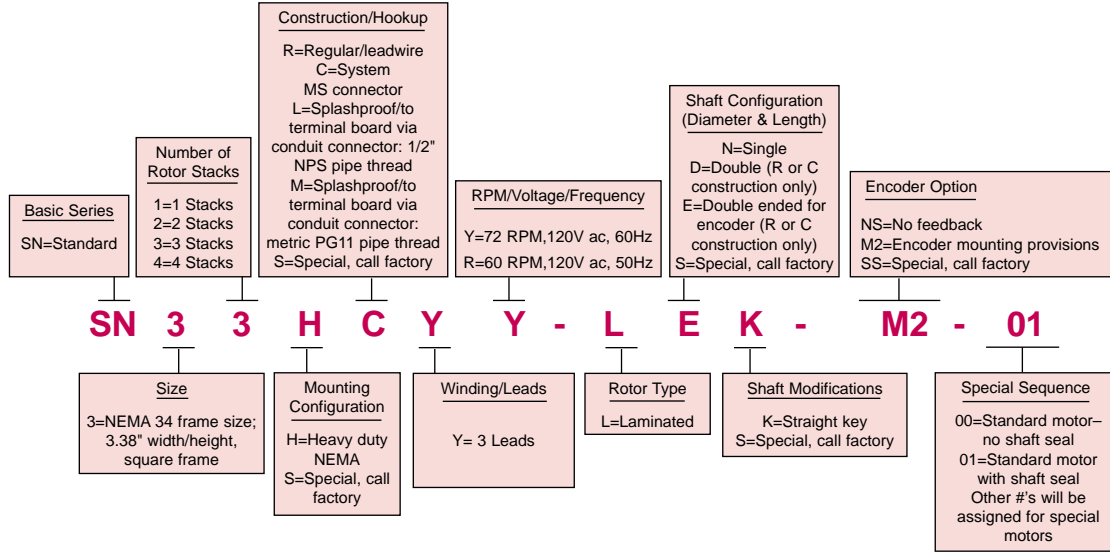

The example model number above indicates a standard NEMA 34 frame motor with a three stack rotor. This motor is equipped with a heavy-duty front end bell and shaft, and a sealed-system rear end bell with MS connectors. It operates at 72 RPM with 120V ac, 60 Hz input voltage. It has a three lead winding, a straight keyway, encoder mounting provisions and a shaft seal.

MODEL NUMBER CODE - NEMA 42 FRAME

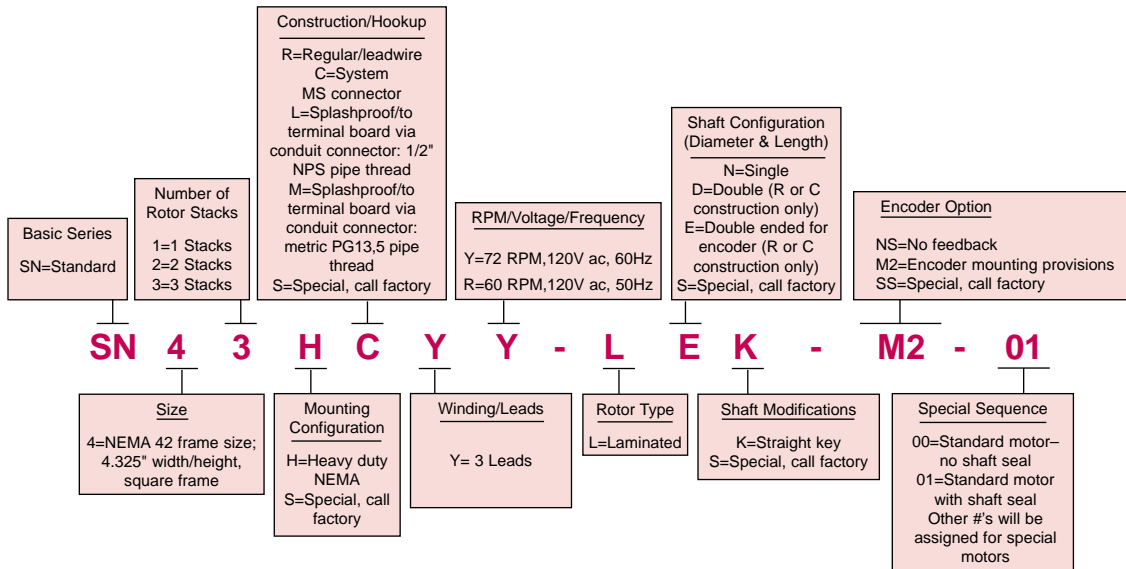

The example model number above indicates a standard NEMA 42 frame motor with a three stack rotor. This motor is equipped with a heavy-duty front end bell and shaft, and a sealed-system rear end bell with MS connectors. It operates at 72 RPM with 120V ac, 60 Hz input power. It has a three lead winding, a straight keyway, encoder mounting options and a shaft seal.

HOW TO ORDER

Review the Motor Model Number Code to assure that all options are designated. Call your nearest Pacific Scientific Motor Products Distributor to place orders and for application assistance. If you need to identify your Distributor, call the Motor Products Division at (815) 226-3100.



OBJY2

POWERSYNC SYNCHRONOUS MOTORS

Sold & Serviced By:
ELECTROMATE
Toll Free Phone (877) SERV098
Toll Free Fax (877) SERV099
www.electromate.com
sales@electromate.com

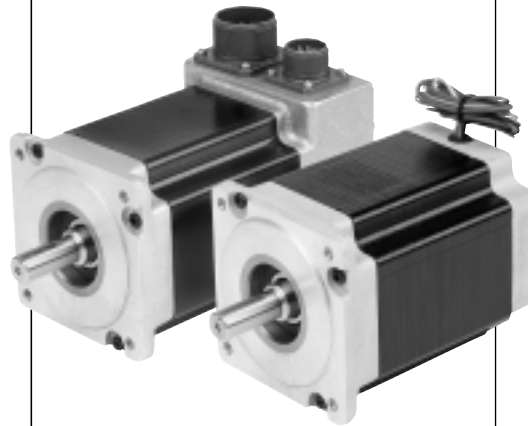

Pacific Scientific synchronous motors deliver bidirectional motion for low velocity, constant speed motor drives. These motors are driven economically from standard AC line voltage and the synchronous speed is related to the line frequency.

Synchronous motor components are identical to those in Pacific Scientific step motors except for high impedance, serially connected stator windings designed for direct operation from AC line voltage.

Synchronous motors are often used rather than geared AC induction motors. The desired speed is easily accomplished by gearing up or down from the synchronous speed using a gear box or simple timing belt and pulleys.

Agency Approval

All NEMA 34 and 42 Frame synchronous motors are UL recognized; Class B motor insulation (File 103510).

Typical Application

- Automatic antennas
- Carousel rotation
- Conveyor systems
- Dispensing machines
- Door openers
- Fluid metering
- Labeling machines
- Packaging machines
- Pumps; medical, process and fuel
- Sorting machines
- Test equipment
- Timing belt drives

FEATURES

With rated torques to 1500 oz-in. (93.75 lb-in.), 10,5 Nm, POWERSYNC provides the highest rated output torque range in the industry

Runs cooler than other AC synchronous motors

Rugged “housingless” square frame

Sealed per NEMA and IP65

Outer bearing races won't turn—front locked (in steel insert) and rear held by O-ring

Selection of terminations
Special shaft configurations available

Easy to apply

Precise speed control

72 RPM, 120V ac, 60 Hz

60 RPM, 120V ac, 50 Hz

Standard NEMA mounting

Motors (unloaded) reach synchronous speed in as little as 2 milliseconds. Ask us about response time at your load

BENEFITS

Optimized magnetics provide maximum performance in a small envelope, reducing space required for the motor. Exceptionally high torques provide unparalleled application freedom for AC synchronous motors

Longer, more reliable motor life—backed by a two year warranty

Efficient use of volume for optimal magnetic design

For splashproof requirements

Long life bearings—also prevents axial shaft movement for encoder applications

Match your requirements

Simple, economical control components (resistor and capacitor)

Synchronous speed for a broad range of applications

For North American use

For international requirements

Widely recognized standard

Fast response for on-off, precisely timed events

POWERSYNC™ SELECTION OVERVIEW

POWERSYNC™ AC SYNCRHONOUS MOTORS

RPM	Voltage	Frequency	Rated torque oz-in. (Nm)	Rated inertia oz-in-S ² (kgm ² x 10 ⁻³)	Page
72	120V ac	60Hz	280-1500 (1,98 - 10,58)	.21-.92 (1,48 - 6,49)	86
60	120V ac	50Hz	375-1440 (2,64 - 10,17)	.29-1.3 (2,05 - 9,18)	87

For assistance in selecting a motor, see page 83.

POWERSYNC™

Ratings and Characteristics

72 RPM, 120 Vac, 60 Hz

Typical Performance Curve

also see p.97

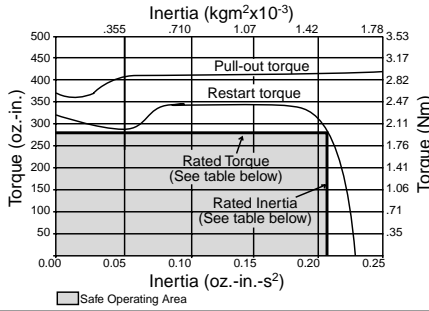

PULL-OUT Torque Curve The maximum friction load, at a particular inertial load, that can be applied to the shaft of an AC synchronous motor (running at constant speed) and not cause it to lose synchronism.

RESTART Torque Curve The maximum friction load, at a particular inertial load, that can be applied to the shaft of an AC synchronous motor without causing it to lose synchronism when accelerating to a constant speed from standstill.

For 72RPM, 120V ac, 60 Hz

NEMA Frame Size (in)	Model Number [△]	Rated Torque oz-in [△] (Nm)	Rated Inertia oz-in-s² [△] (kgm²x10⁻³)	Max. Pull-out Torque oz-in (Nm)	RMS per Phase Current @ 80% Pull-out (Amps)	Detent Torque oz-in (Nm)	Thermal Res. [△] (°C/watt)	Phase Res. (Ohms)	Phase Ind. (mH)	Rotor Inertia oz-in-s² [△] (kgm²x10⁻³)	Weight lbs (kg)
34	SN31HXYY-LXK-XX-XX	280 (1,98)	0.21 (1,48)	410 (2,9)	0.38	18 (0,13)	2.7	86	601	0.0202 (0,14)	5 (2,27)
34	SN32HXYY-LXK-XX-XX	480 (3,39)	0.29 (2,05)	690 (4,87)	0.47	36 (0,25)	2	38	383	0.038 (0,27)	8.4 (3,81)
34	SN33HXYY-LXK-XX-XX	690 (4,87)	0.53 (3,74)	1015 (7,17)	0.78	54 (0,38)	1.6	32	362	0.0567 (0,4)	11.9 (5,39)
34	SN34HXYY-LXK-XX-XX	900 (6,36)	0.53 (3,74)	1520 (10,73)	1.43	57 (0,4)	1.3	16	191	0.075 (0,53)	15.1 (6,84)
42	SN41HXYY-LXK-XX-XX	715 (5,05)	0.4 (2,82)	1045 (7,38)	0.8	42 (0,3)	1.9	21	334	0.0783 (0,55)	11 (4,98)
42	SN42HXYY-LXK-XX-XX	1200 (8,47)	0.82 (5,79)	1580 (11,16)	1.19	84 (0,59)	1.3	9.5	198	0.1546 (1,09)	18.4 (8,34)
42	SN43HXYY-LXK-XX-XX	1500 (10,59)	0.92 (6,49)	2000 (14,12)	1.46	106 (0,75)	1	7.2	148	0.2293 (1,62)	25.7 (11,64)

[△] An "X" in the Model Number Code indicates an undefined option. See page 83.

[△] Rated Torque and Inertia are maximum values. The rated torque is the combination of load torque and friction torque. The motor will accelerate and run at synchronous speed, delivering the rated torque value while moving an inertia up to the rated inertia value. Rated inertia is a combination of the load inertia and the motor's rotor inertia. For assistance in motor selection, see page 95.

[△] Rated Torque and Rated Inertia denote restart conditions with a stiff coupling of .3 arc sec/oz-in. minimum.

[△] Detent torque is the maximum torque that can be applied to an unenergized step motor without causing continuous rotating motion.

[△] Thermal resistance from motor winding to ambient with motor hanging in still air, unmounted.

[△] Small signal inductance as measured with impedance bridge at 1kHz, 1 amp.

R-C PHASE SHIFT NETWORKS

A phase shift network is required and values have been selected to eliminate reversing torque and motor oscillations during motor startup. The network is placed in the circuit as shown in the diagram below. It is important to use the recommended values for the resistor and capacitor which vary with each motor, see p. 100. The resistors and capacitors are standard and are readily available from electronic component suppliers.

For 72RPM, 120V ac, 60 Hz

Model Number	Resistor		Capacitor	
	(Ohms)	(Watts)	(µf)	(rated Vac)
SN31HXYY-LXK-XX-XX	200	50	6	370
SN32HXYY-LXK-XX-XX	200	50	10	370
SN33HXYY-LXK-XX-XX	100	100	10	370
SN34HXYY-LXK-XX-XX	50	100	17.5	370
SN41HXYY-LXK-XX-XX	100	100	12.5	370
SN42HXYY-LXK-XX-XX	75	100	20	370
SN43HXYY-LXK-XX-XX	50	100	20	370

Schematic Diagram All Constructions

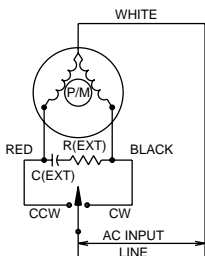

POWERSYNC™

Ratings and Characteristics

60 RPM, 120 Vac, 50 Hz

Typical Performance Curve

also see p.97

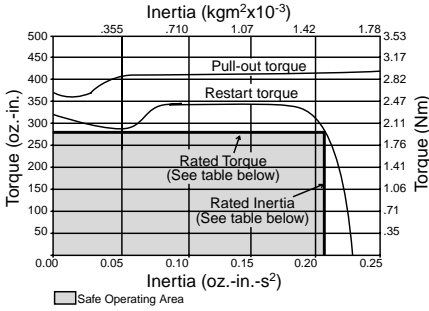

PULL-OUT Torque Curve The maximum friction load, at a particular inertial load, that can be applied to the shaft of an AC synchronous motor (running at constant speed) and not cause it to lose synchronism.

RESTART Torque Curve The maximum friction load, at a particular inertial load, that can be applied to the shaft of an AC synchronous motor without causing it to lose synchronism when accelerating to a constant speed from standstill.

For 60RPM, 120V ac, 50 Hz

NEMA Frame Size (in)	Model Number [△]	Rated Torque [△] oz-in [△] (Nm)	Rated Inertia [△] oz-in-s ² [△] (kgm ² x10 ⁻³)	Max. Pull-out Torque oz-in (Nm)	RMS per Phase Current @ 80% Pull-out (Amps)	Detent Torque oz-in (Nm)	Thermal Res. [△] (°C/watt)	Phase Res. (Ohms)	Phase Ind. (mH)	Rotor Inertia oz-in-s ² [△] (kgm ² x10 ⁻³)	Weight lbs (kg)
34	SN31HXYR-LXK-XX-XX	375 (2,64)	0.29 (2,05)	490 (3,46)	0.34	18 (0,13)	2.7	136	990	0.0202 (0,14)	5 (2,27)
34	SN32HXYR-LXK-XX-XX	600 (4,24)	0.52 (3,67)	870 (6,14)	0.64	36 (0,25)	2	53	493	0.038 (0,27)	8.4 (3,81)
34	SN33HXYR-LXK-XX-XX	800 (5,65)	0.6 (4,23)	1120 (7,91)	0.67	54 (0,38)	1.6	35	417	0.0567 (0,4)	11.9 (5,39)
34	SN34HXYR-LXK-XX-XX	990 (6,99)	0.53 (3,74)	1565 (11,05)	1.1	57 (0,4)	1.3	18	226	0.075 (0,53)	15.1 (6,84)
42	SN41HXYR-LXK-XX-XX	700 (4,94)	0.53 (3,74)	1060 (7,49)	0.71	42 (0,3)	1.9	33	513	0.0783 (0,55)	11 (4,98)
42	SN42HXYR-LXK-XX-XX	1020 (7,22)	1.16 (8,19)	1575 (11,12)	0.93	84 (0,59)	1.3	15	300	0.1546 (1,09)	18.4 (8,34)
42	SN43HXYR-LXK-XX-XX	1440 (10,17)	1.3 (9,18)	2000 (14,12)	1.6	106 (0,75)	1	12	267	0.2293 (1,62)	25.7 (11,64)

[△] An "X" in the Model Number Code indicates an undefined option. See page 83.

[△] Rated Torque and Inertia are maximum values. The rated torque is the combination of load torque and friction torque. The motor will accelerate and run at synchronous speed, delivering the rated torque value while moving an inertia up to the rated inertia value. Rated inertia is a combination of the load inertia and the motor's rotor inertia. For assistance in motor selection, see page 95.

[△] Rated Torque and Rated Inertia denote restart conditions with a stiff coupling of .3 arc sec/oz-in. minimum.

[△] Detent torque is the maximum torque that can be applied to an unenergized step motor without causing continuous rotating motion.

[△] Thermal resistance from motor winding to ambient with motor hanging in still air, unmounted.

[△] Small signal inductance as measured with impedance bridge at 1kHz, 1 amp.

R-C PHASE SHIFT NETWORKS

A phase shift network is required and values have been selected to eliminate reversing torque and motor oscillations during motor startup. The network is placed in the circuit as shown in the diagram below. It is important to use the recommended values for the resistor and capacitor which vary with each motor, see p. 100. The resistors and capacitors are standard and are readily available from electronic component suppliers.

For 60RPM, 120V ac, 50 Hz

Model Number	Resistor		Capacitor	
	(Ohms)	(Watts)	(μ f)	(rated Vac)
SN31HXYR-LXK-XX-XX	150	25	2	2.75
SN32HXYR-LXK-XX-XX	100	50	4	4.75
SN33HXYR-LXK-XX-XX	100	50	4	4.75
SN34HXYR-LXK-XX-XX	75	100	6.5	7.38
SN41HXYR-LXK-XX-XX	100	50	4	4.75
SN42HXYR-LXK-XX-XX	100	100	6.5	7.38
SN43HXYR-LXK-XX-XX	50	225	10.5	11.38

Schematic Diagram All Constructions

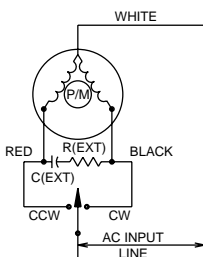

DIMENSIONS . . . POWERSYNC™

in. (metric dimensions for ref. only)
 mm

NEMA 34 FRAME: All motors have a heavy duty NEMA front end bell and large diameter shaft to support the higher output torques

LEADWIRE HOOKUP - ENCODER OPTIONS

Model Number Code designation R (Construction/Hookup), p.83

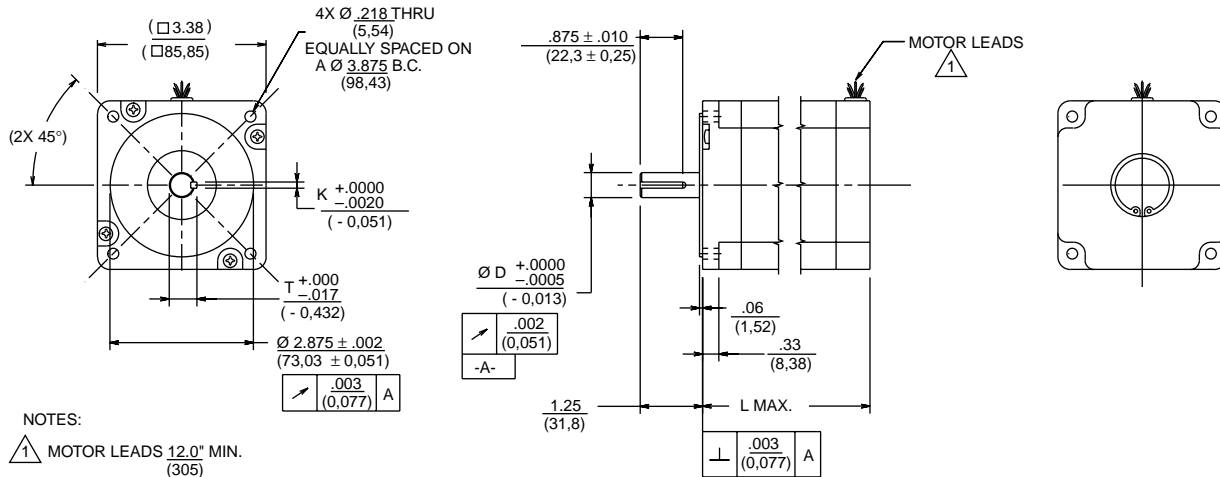

MOTOR*	D	K	T	L MAX.
31HR	.5000 (12,70)	.1250 (3,175)	.555 (14,09)	3.13 (79,5)
32HR	.5000 (12,70)	.1250 (3,175)	.555 (14,09)	4.65 (118,1)
33HR	.6250 (15,875)	.1875 (4,763)	.705 (17,91)	6.17 (156,7)
34HR	.6250 (15,875)	.1875 (4,763)	.705 (17,91)	7.68 (195,1)

*See Model Number Code, p 83.

LEADWIRE HOOKUP DOUBLE SHAFT CONFIGURATION

Model Number Code designation D (Shaft Configuration), p. 83

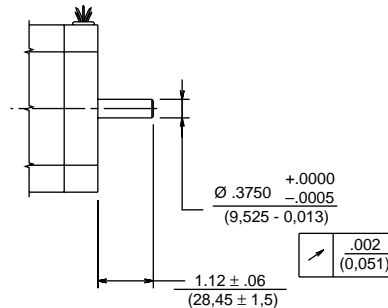

LEADWIRE HOOKUP ENCODER MOUNTING PROVISION

Model Number Code designation M2 (Encoder Mounting Option), p.83

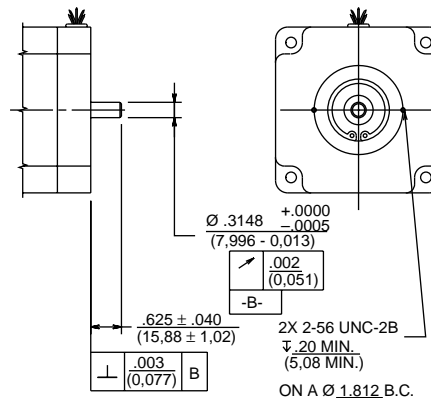

in. (metric dimensions for ref. only)
 mm

NEMA 34 FRAME: All motors have a heavy duty NEMA front end bell and large diameter shaft to support the higher output torques

SPLASHPROOF CONSTRUCTION/TERMINAL BOARD CONNECTIONS

(via English or Metric thread for conduit) Model Number Code designation L or M (Construction/Hookup), p 83

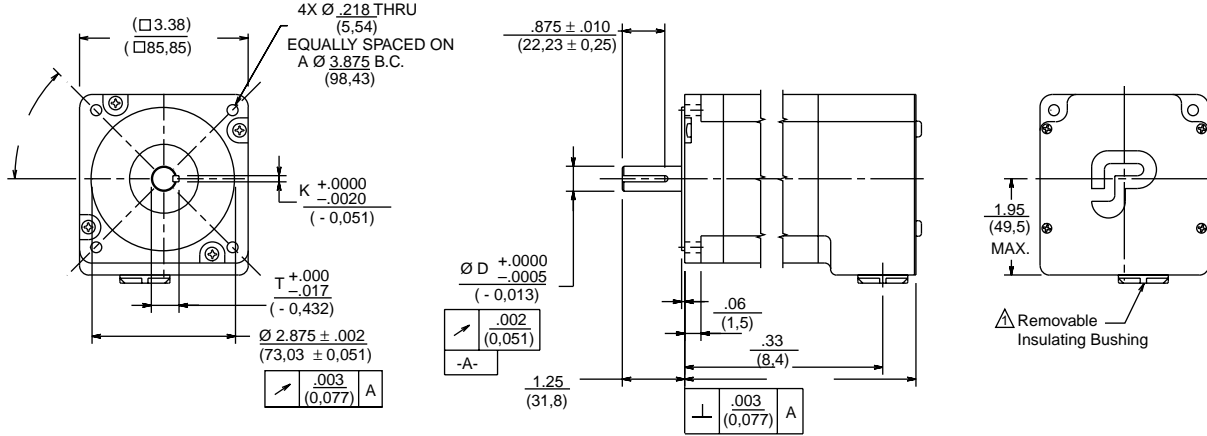

MOTOR*	D	K	T	X	L MAX.
31HR	.5000 (12,70)	.1250 (3,175)	.555 (14,09)	3.70 (93,9)	4.44 (112,8)
32HR	.5000 (12,70)	.1250 (3,175)	.555 (14,09)	5.22 (132,6)	5.96 (151,4)
33HR	.6250 (15,875)	.1875 (4,763)	.705 (17,91)	6.74 (171,20)	7.48 (189,9)
34HR	.6250 (15,875)	.1875 (4,763)	.705 (17,91)	8.25 (209,6)	8.99 (228,4)

*See Model Number Code, p 83.

SPLASHPROOF CONSTRUCTION/MS CONNECTOR(S)— ENCODER OPTION

Model Number Code designation C/System (Construction/Hookup) and Encoder Mounting Option, p 83

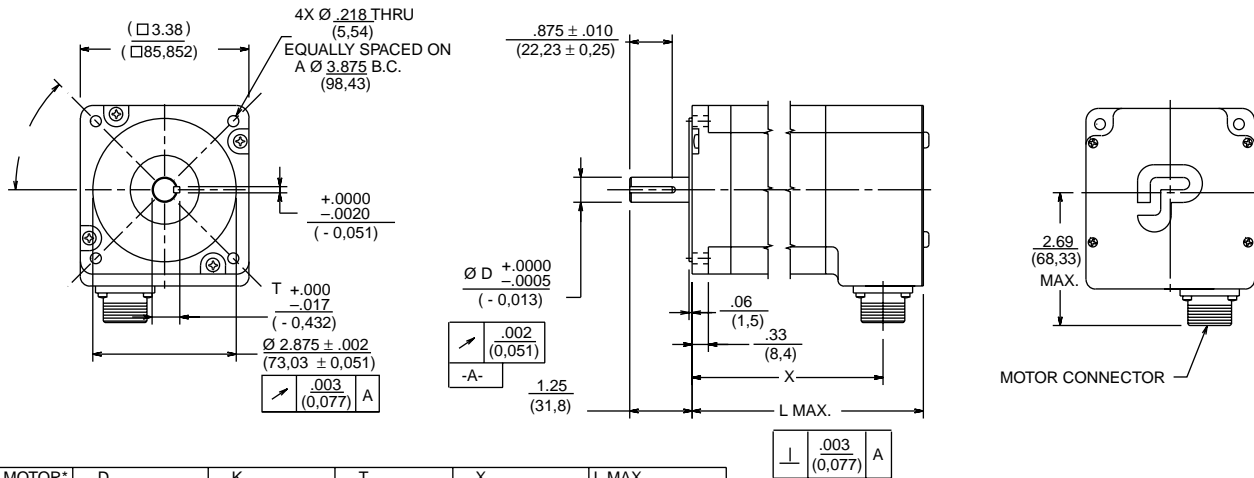

MOTOR*	D	K	T	X	L MAX.
31HR	.5000 (12,70)	.1250 (3,175)	.555 (14,09)	3.56 (90,42)	4.44 (112,8)
32HR	.5000 (12,70)	.1250 (3,175)	.555 (14,09)	5.07 (128,78)	5.96 (151,4)
33HR	.6250 (15,875)	.1875 (4,763)	.705 (17,91)	6.59 (167,39)	7.48 (189,9)
34HR	.6250 (15,875)	.1875 (4,763)	.705 (17,91)	8.11 (205,99)	8.99 (228,4)

*See Model Number Code, p 83.

ENCODER MOUNTING OPTION

NOTES:

- △ L Construction = Conduit connection (1/2 NPSC TAP) with $\frac{56}{14,2}$ I.D. removable insulating bushing
- M Construction = Conduit connection (PG 11 TAP). (No insulating bushing supplied)

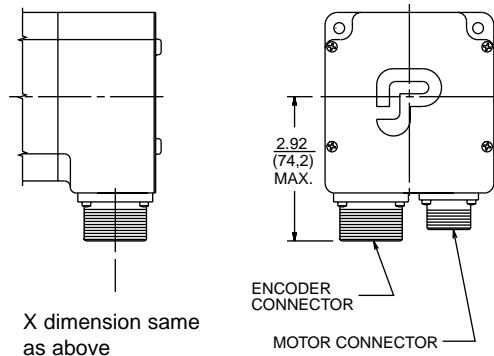

DIMENSIONS . . . POWERSYNC™

in. (metric dimensions for ref. only)
 mm

NEMA 42 FRAME: All motors have a heavy duty NEMA front end bell and large diameter shaft to support the higher output torques

LEADWIRE HOOKUP

Model Number Code designation R (Construction/Hookup), p. 83

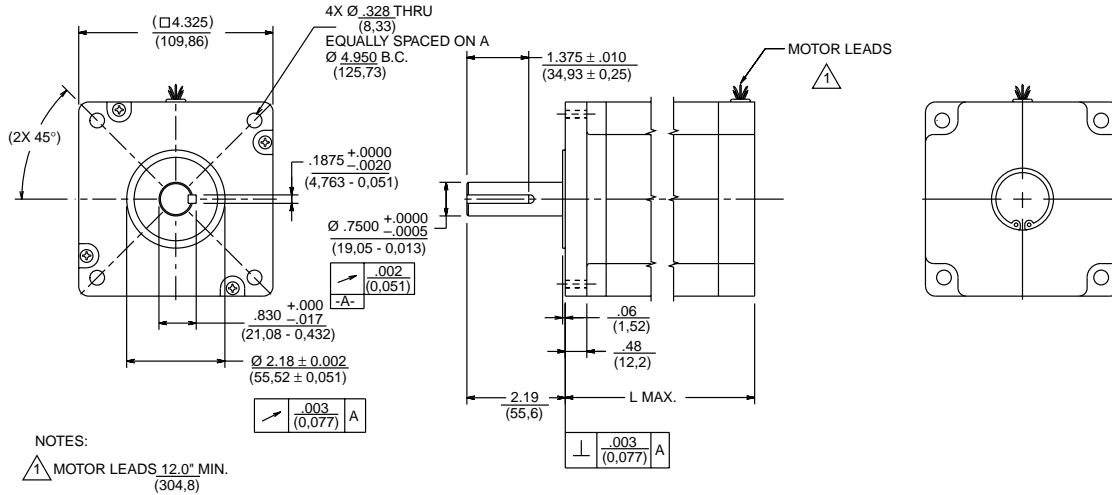

MOTOR*	L MAX.
41HR	3.89 (98,8)
42HR	5.91 (150,1)
43HR	7.92 (201,2)

* See Model Number Code, p.83

LEADWIRE HOOKUP DOUBLE SHAFT CONFIGURATION

Model Number Code designation D (Shaft Configuration), p. 83
 Available on R construction only.

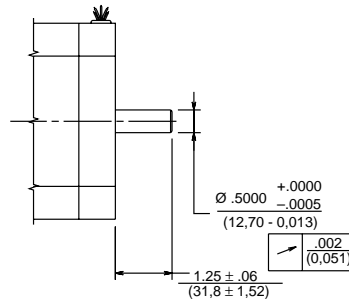

LEADWIRE HOOKUP ENCODER MOUNTING PROVISION

Model Number Code designation M2 (Encoder Mounting Option), p.83

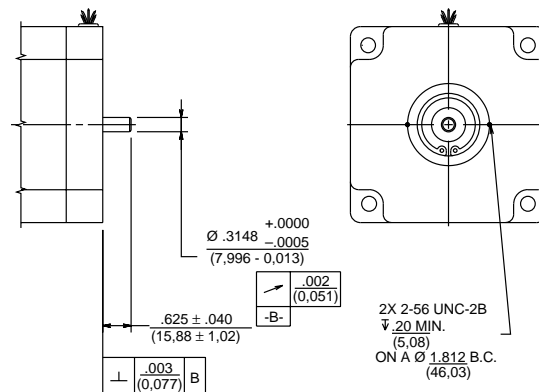

DIMENSIONS . . . POWERSYNC™

in. (metric dimensions for ref. only)
 mm

NEMA 42 FRAME: All motors have a heavy duty NEMA front end bell and large diameter shaft to support the higher output torques

SPLASHPROOF CONSTRUCTION/TERMINAL BOARD CONNECTIONS

(via English or Metric thread for conduit) Model Number Code designation L or M (Construction/Hookup), p. 83.

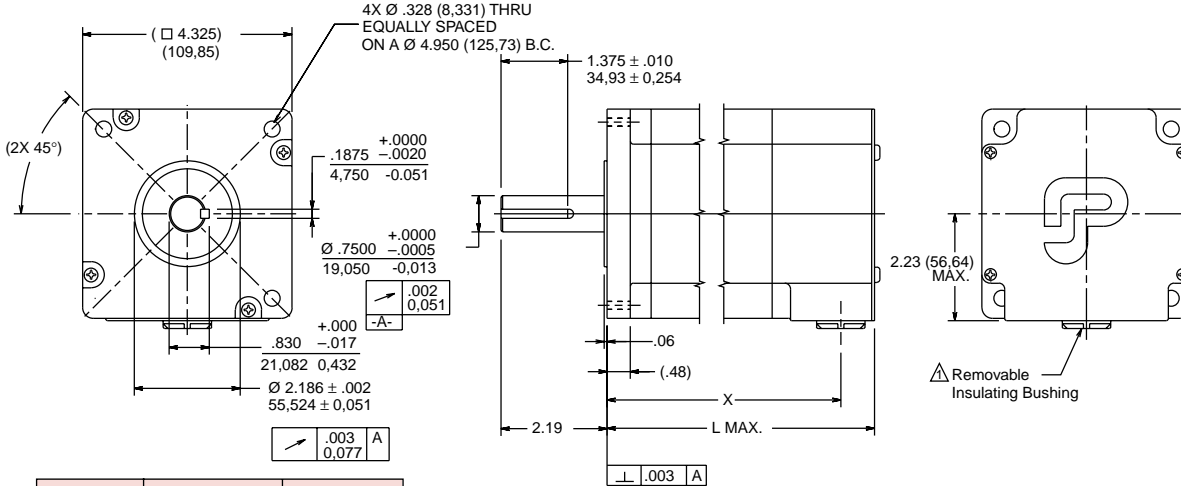

MOTOR*	X	L MAX.
41HR	4.46 (113,3)	3.89 (98,9)
42HR	6.48 (164,6)	5.91 (150,1)
43HR	8.49 (215,7)	7.92 (201,2)

* See Model Number Code, p.83

SPLASHPROOF CONSTRUCTION/MS CONNECTOR(S)— ENCODER OPTION

Model Number Code designation C/System (Construction/Hookup) and Encoder Mounting Option, p. 83.

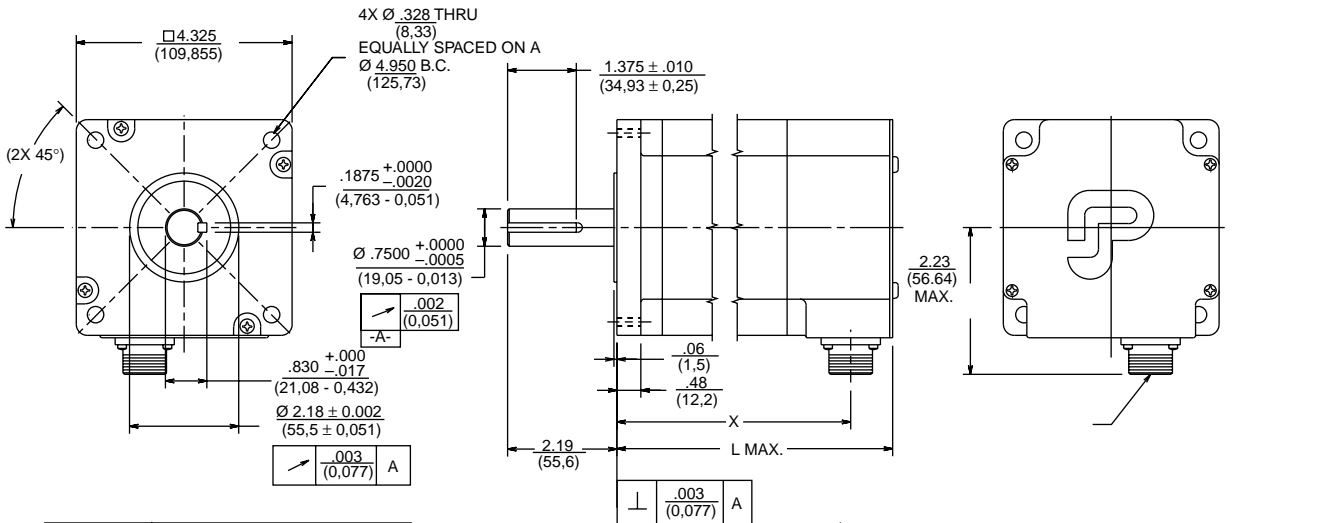

MOTOR*	X	L MAX.
41HR	4.32 (109,7)	5.20 (132,1)
42HR	6.33 (160,8)	7.22 (183,4)
43HR	8.35 (212,1)	9.23 (234,4)

* See Model Number Code, p.83

NOTES:

△ L Construction = Conduit connection (1/2 NPSC TAP) with $\frac{56}{14,2}$ I.D. removable insulating bushing

M Construction = Conduit connection (PG 13, 5 TAP). (No insulating bushing supplied)

ENCODER MOUNTING OPTION

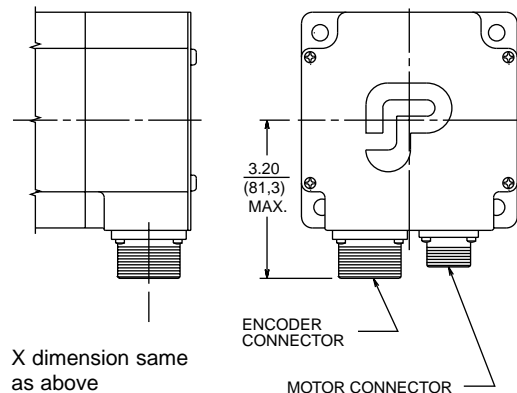

X dimension same as above

ENCODER CONNECTOR
 MOTOR CONNECTOR