

Vertical/Rotation **ZR-S/M**

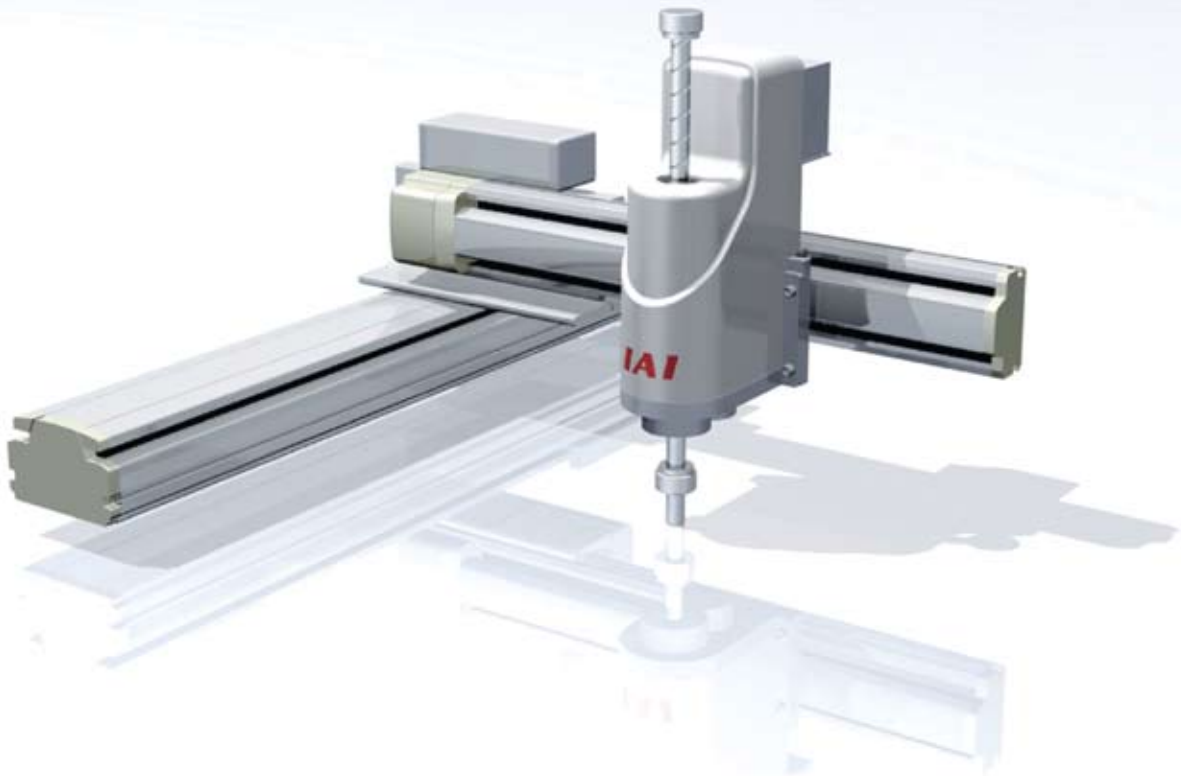







# ZR Series

ZR-S (Small Type) – ZR-M (Medium Type)

High Speed Vertical/Rotation Electric Actuator



-  Max Stroke: 200mm / 360°
-  Max Payload: 6kg
-  Controller: XSEL
-  Max Speed: 1256mm/s - 2200°/s
-  Max Positions: 20,000 points
-  Controller Voltage: 200V

<b>ZR</b>						<b>T2</b>		
Series	Type	Encoder type	Z-Axis Motor	Z-Axis Lead	Stroke	Applicable controller	Cable length	Options
	S Small Type (Z-Axis 100W / R-Axis 100W) M Medium Type (Z-Axis 200W / R-Axis 200W)	A Absolute I Incremental	100 100W (S Type) 200 200W (M Type)	16 16mm (S Type) 20 20mm (M Type)	150 150mm (S Type) 200 200mm (M Type)	T2 XEL-P/Q	N No Cable S 3m M 5m X□ Specified Length	B Brake (Z-Axis) L Limit switch (Rotation)

## 1. Add the ZR Unit to a 2-axis System to Create a High Speed 4-axis System

Because of the compact construction of the ZR unit, it is possible to add the ZR unit as a standard configuration to the ICSA/ICSPA series actuators. Take your manufacturing to higher levels of efficiency and productivity.

## 2. High Speed Rotation

The high speed R-axis is capable of up to 2200°/s and will cut your cycle time, improving ROI.

## 3. 2 Sizes to Fit Your Application

Select the small or medium type ZR unit with either the absolute or incremental encoder.

Specifications		ZR-S (Small Type)	ZR-M (Medium Type)
Motor Output	Z-Axis (Vertical) (W)	100	200
	R-Axis (Rotation) (W)	100	200
Work Envelope	Z-Axis (Vertical) (mm)	150	200
	R-Axis (Rotation) (Deg)	±360°	±360°
Maximum Operating Speed	Z-Axis (Vertical) (mm/s)	1005	1256
	R-Axis (Rotation) (Deg/s)	2200°	2200°
Load Capacity	Rated (kg)	1	2
	Max (kg)	3	6

# ICSA4/ICSPA4 Series

XY 2-axis combination + ZR (Z-axis and rotation axis)

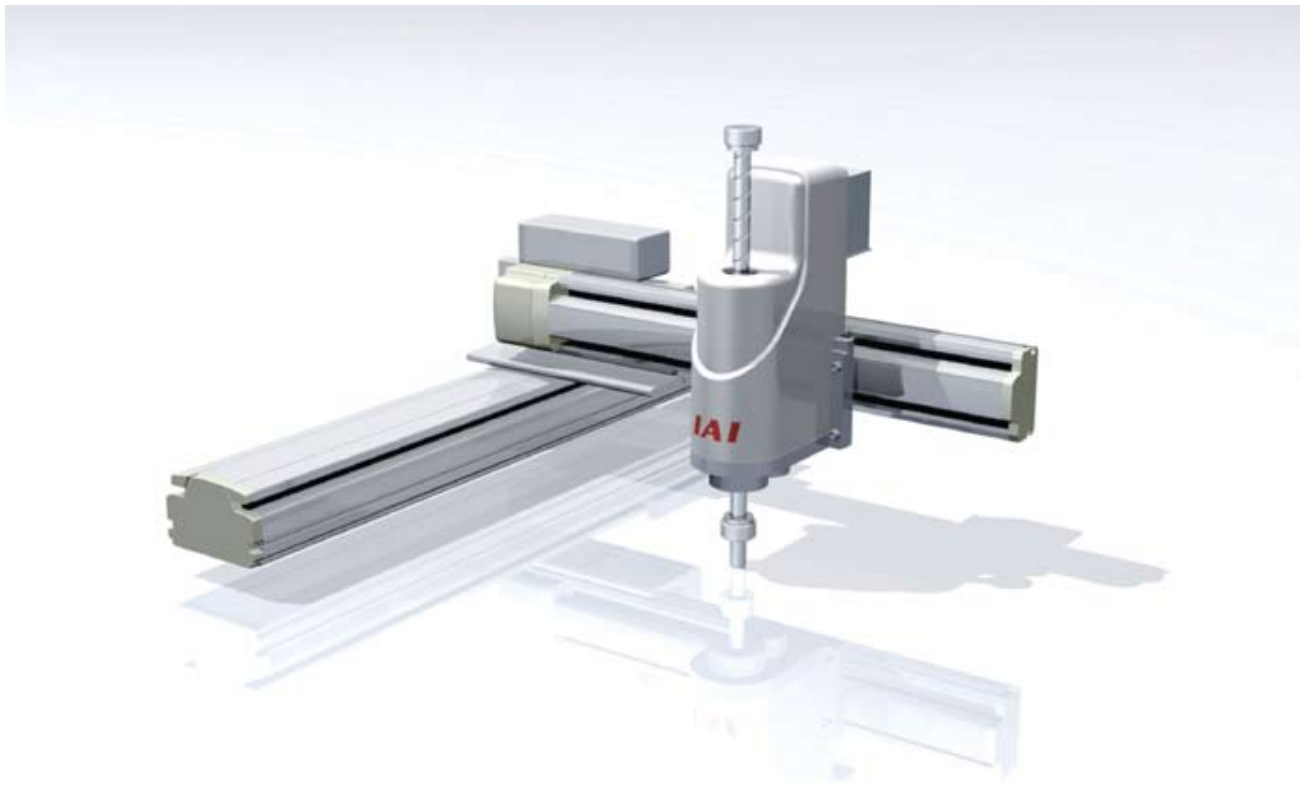
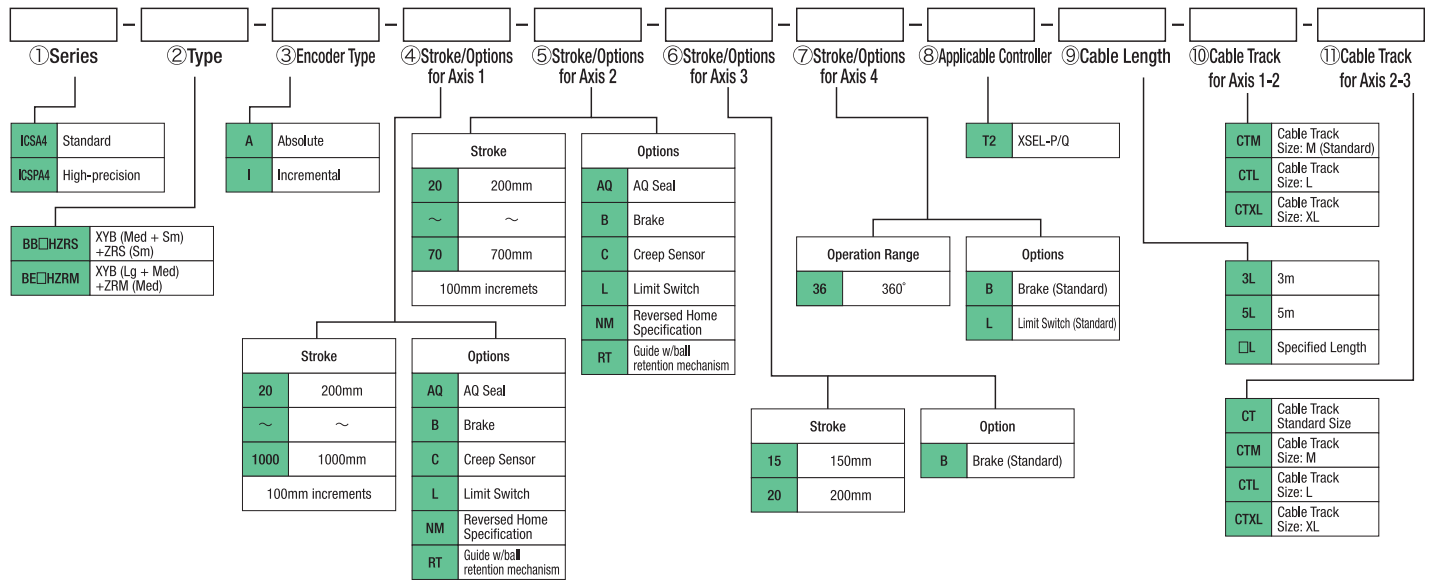

# ZR-S

Vertical/Rotational Axis Integrated Type, Compact type, 100W



Model	ZR	-	S	-	[ ]	-	100	-	16	-	150	-	T2	-	[ ]	-	B	-	L
Series	Type	Encoder Type	Motor Type	Z-axis lead	Z-axis stroke	Applicable Controller	Cable Length	Options											
A: Absolute    100:100W    16:16mm    150:150mm    T2:XSEL I: Incremental													N: None S: 3m M: 5m X□□: Specified Length		B: Brake (standard feature) L: Limit switch (standard feature on rotational axis)				

## Models/Specifications

Model	Axis Configuration	Encoder Type	Motor Capacity (W)	Operation Range	Positioning Repeatability (mm)	Maximum Operating Speed (note 1)	Loading Capacity (kg)		Vertical Axis Push force (N)		Rotational Axis Allowable load	
							Rated (note 2)	Max (note 2)	Push motion operation (note 3)	Max thrust (note 3)	Allowable inertial moment (kg·m²)(note 4)	Allowable torque (N·m)
ZR-S-①-100-16-150-T2-②-B-L	Vertical axis Rotational axis	Absolute Incremental	100	150mm	±0.010	1005mm/s	1	3	74.8	107	0.015	1.9
			100	±360°	±0.005	2200°/s						

\* In the above model name, ① indicates the encoder type, while ② indicates the cable length.

## Options

Name	Option code	Remarks
Brake	B	Standard feature on vertical axis/rotational axis
Home Limit Switch	L	Standard feature on rotational axis

\* The following adjustment jig (sold separately) is required for the absolute specification.  
Absolute reset adjustment jig (model: JG-ZRS)

## Actuator Specifications

Encoder type	Absolute / Incremental
Actuator weight	5.5kg
Applicable controller	T2 : XSEL-P/Q
Cable Length (note 5)	N : No cable, S : 3m, M : 5m, X□□ : Specified length
Ambient operating temp/humidity	Temperature 0 to 40°C, Humidity 20 to 85% RH max. (non-condensing)

## Dimensions

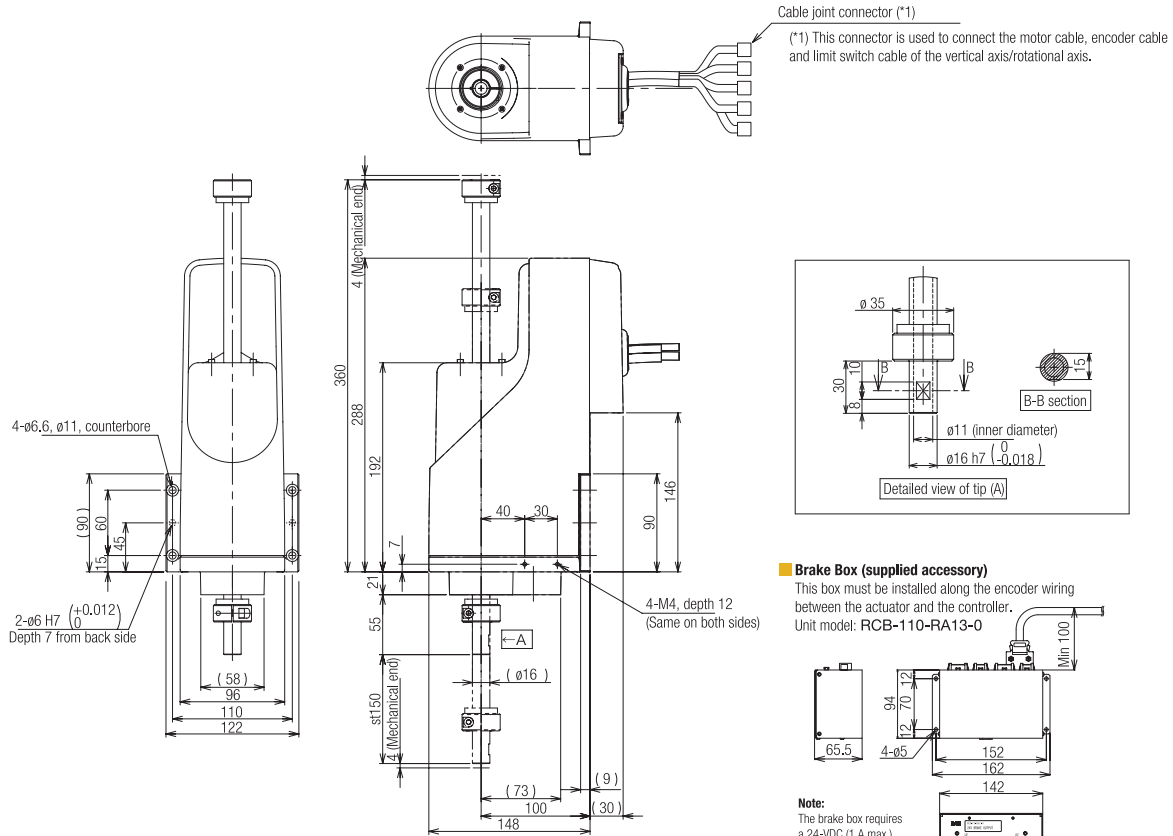

### Brake Box (supplied accessory)

This box must be installed along the encoder wiring between the actuator and the controller.  
Unit model: RCB-110-RA13-0

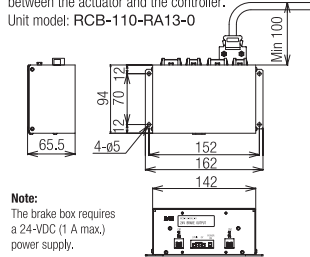

## Applicable Controller Specifications

Applicable Controller	Max number of controlled axes	Connectable encoder type	Operating method	Power-supply voltage
X-SEL-P/Q	6 axes	Absolute/incremental	Program	Single-phase/3-phase 200 VAC



Caution

(Note 1) Based on PTP command operation.

(Note 2) The rated loading capacity assumes operation at an acceleration/deceleration of 0.3g, while the maximum loading capacity assumes operation at an acceleration/deceleration of 0.1g.

(Note 3) The push force of the vertical axis represents the force that pushes an object at the tip of the vertical axis. The value indicated under "Push-motion operation" corresponds to the maximum push force when a push command is executed in the program. The value indicated under "Maximum thrust" corresponds to the maximum thrust achieved during normal positioning operation. If you are performing push-motion operation, be sure to use a push command in the program.

(Note 4) Allowable inertial moment converted to an equivalent value at the center of the rotational axis. The actual value may be lower depending on the conditions of use.

(Note 5) The maximum cable length is 30m. Specify a desired length in meters. (Example X08 = 8m)

# ZR-M

Vertical/Rotational Axis Integrated Type, Medium size type, 200W



<b>Model</b>	<b>ZR</b>	<b>- M</b>	<b>-</b>	<b>200</b>	<b>- 20</b>	<b>- 200</b>	<b>- T2</b>	<b>-</b>	<b>B</b>	<b>- L</b>
Series	Type	Encoder Type	Motor Type	Z-axis lead	Z-axis stroke	Applicable Controller	Cable Length		Options	
A: Absolute I: Incremental	200:200W	20:20mm	200:200mm	T2:XSEL-P/Q	N: None S: 3m M: 5m X□□: Specified Length				B: Brake (standard feature) L: Limit switch (standard feature on rotational axis)	

## Models/Specifications

Model	Axis Configuration	Encoder Type	Motor Capacity (W)	Operation Range	Positioning Repeatability (mm)	Maximum Operating Speed (note 1)	Loading Capacity (kg)		Vertical Axis Push force (N)		Rotational Axis Allowable load	
							Rated (note 2)	Max (note 2)	Push motion operation (note 3)	Max thrust (note 3)	Allowable inertial moment (kg·m <sup>2</sup> )(note 4)	Allowable torque (N·m)
ZR-M-①-200-20-200-T2-②-B-L	Vertical axis Rotational axis	Absolute Incremental	200 200	200mm ±360°	±0.010 ±0.005	1256mm/s 2200°/s	2	6	120	171	0.03	3.8

\* In the above model name, ① indicates the encoder type, while ② indicates the cable length.

## Options

Name	Option code	Remarks
Brake	B	Standard feature on vertical axis/rotational axis
Home Limit Switch	L	Standard feature on rotational axis

\* The following adjustment jig (sold separately) is required for the absolute specification. Absolute reset adjustment jig (model: JG-ZRM)

## Actuator Specifications

Encoder type	Absolute / Incremental
Actuator weight	8kg
Applicable controller	T2 : XSEL-P/Q
Cable Length (note 5)	N : No cable, S : 3m, M : 5m, X□□ : Specified length
Ambient operating temp/humidity	Temperature 0 to 40°C, Humidity 20 to 85% RH max. (non-condensing)

## Dimensions

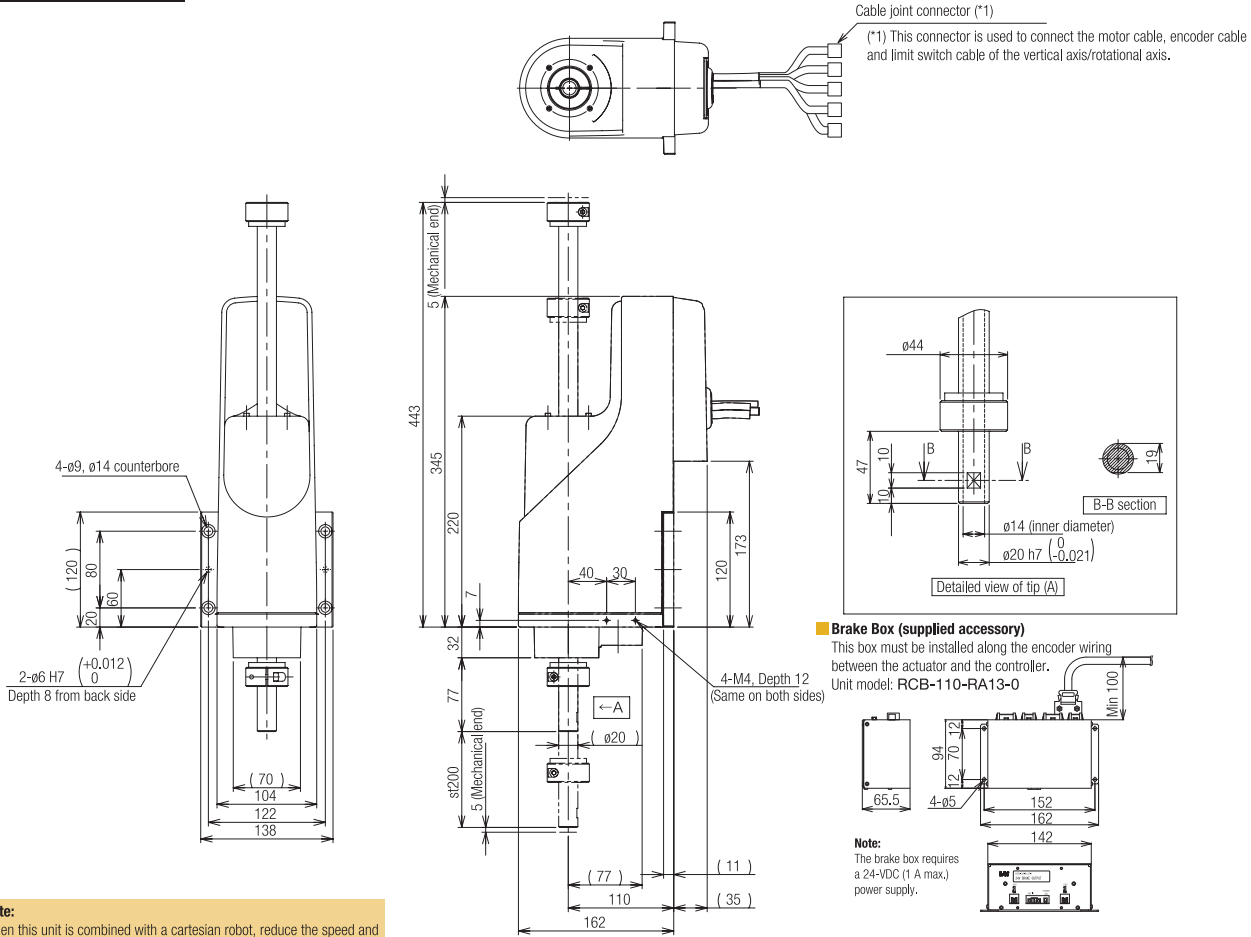

## Applicable Controller Specifications

Applicable Controller	Max number of controlled axes	Connectable encoder type	Operating method	Power-supply voltage
X-SEL-P/Q	6 axes	Absolute/incremental	Program	Single-phase/3-phase 200 VAC



(Note 1) Based on PTP command operation.  
 (Note 2) The rated loading capacity assumes operation at an acceleration/deceleration of 0.3G, while the maximum loading capacity assumes operation at an acceleration/deceleration of 0.1G.  
 (Note 3) The push force of the vertical axis represents the force that pushes an object at the tip of the vertical axis. The value indicated under "Push-motion operation" corresponds to the maximum push force when a push command is executed in the program. The value indicated under "Maximum thrust" corresponds to the maximum thrust achieved during normal positioning operation. If you are performing push-motion operation, be sure to use a push command in the program.  
 (Note 4) Allowable inertial moment converted to an equivalent value at the center of the rotational axis. The actual value may be lower depending on the conditions of use.  
 (Note 5) The maximum cable length is 30m. Specify a desired length in meters. (Example X08 = 8m)

# ICSA4-BB □ HZRS

Cartesian Robot 4-axis Combination of XY and ZR Unit

# ICSPA4-BB □ HZRS

Cartesian Robot 4-axis Combination of XY and ZR Unit

## High-precision Specification

<b>Model</b>	Series	Type	Encoder	Stroke/options for axis 1	Stroke/options for axis 2	Stroke/options for axis 3	Operation range/Options for axis 4	Controller	Cable Length	Cable wiring for X-axis	Cable wiring for Z-axis
ICSA4: Standard 4-axis Specification	BB □ HZRS	Refer to model table below	A: Absolute I: Incremental	20:200mm 80:800mm (100mm steps)	10:100mm 40:400mm (100mm steps)	15:150mm	36:360 Deg	T2:XSEL-P/Q	3L:3m 5L:5m	Refer to Explanations of Symbols in Model Names below	Refer to Explanations of Symbols in Model Names below
ICSPA4: High-precision 4-axis Specification											

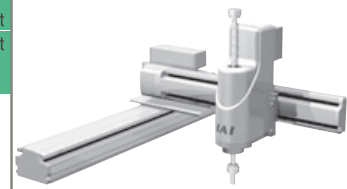

### Model

\* Models of high-precision specification are shown in [ ].

Encoder Model	XY combination direction (*1)	Z-axis Type	Model
Absolute	1	H	ICSA4 [ICSPA4]-BB1HZRS-A-[1]-[2]-[3]B-[4]BL-[5]-[6]-[7]-[8]
	2	H	ICSA4 [ICSPA4]-BB2HZRS-A-[1]-[2]-[3]B-[4]BL-[5]-[6]-[7]-[8]
	3	H	ICSA4 [ICSPA4]-BB3HZRS-A-[1]-[2]-[3]B-[4]BL-[5]-[6]-[7]-[8]
	4	H	ICSA4 [ICSPA4]-BB4HZRS-A-[1]-[2]-[3]B-[4]BL-[5]-[6]-[7]-[8]
Incremental	1	H	ICSA4 [ICSPA4]-BB1HZRS-I-[1]-[2]-[3]B-[4]BL-[5]-[6]-[7]-[8]
	2	H	ICSA4 [ICSPA4]-BB2HZRS-I-[1]-[2]-[3]B-[4]BL-[5]-[6]-[7]-[8]
	3	H	ICSA4 [ICSPA4]-BB3HZRS-I-[1]-[2]-[3]B-[4]BL-[5]-[6]-[7]-[8]
	4	H	ICSA4 [ICSPA4]-BB4HZRS-I-[1]-[2]-[3]B-[4]BL-[5]-[6]-[7]-[8]

\*1 See the figure below for the XY combination directions.

\* For the descriptions of [1] to [8] in the above model names, refer to the table provided in the top right.

\* The following adjustment jig (sold separately) is required for models of absolute specification:  
Absolute reset adjustment jig (model: JG-ZRS)

### Explanation of Symbols in Model Names

No.	Description	Value
[1]	X-axis stroke (Note 1)	20 : 200mm 80 : 800mm
[2]	Y-axis stroke (Note 1)	10 : 100mm 40 : 400mm
[3]	Z-axis stroke (Note 1)	15 : 150mm
[4]	R-axis Operation Range	36 : 360deg
[5]	Applicable Controllers	T2 : XSEL-P/Q
[6]	Cable Length (Note 2)	3L : 3m 5L : 5m
[7]	Y-axis Cable Wiring	CTM: Cable track size M (Standard) CTL: Cable track size L CTXL: Cable track size XL
[8]	Z-axis Cable Wiring	CT: Cable Track (Standard) CTM: Cable track size M CTL: Cable track size L CTXL: Cable track size XL

\*The above table describes [1] to [8] in the model names shown to the left.

### Options

Enter the applicable option symbol after the stroke of each axis. If multiple options are selected, enter them in alphabetical order.

Name	Model
AQ Seal	AQ
Brake	B
Creep Sensor	C
Home Limit Switch	L
Reversed Home Specification	NM
Guide with ball retention mechanism	RT

### XY Combination Directions

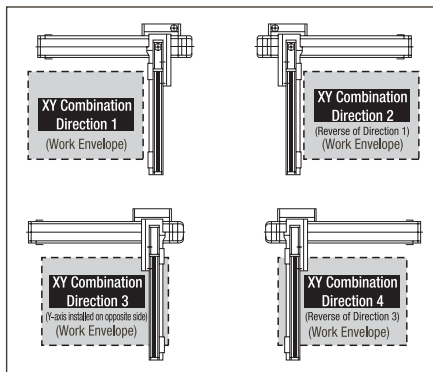

### Common Specifications

\* Models of high-precision specification are shown in [ ].

Drive Method	Ball screw, rolled C10 [rolled C5 or equivalent]
Positioning Repeatability	±0.02mm [±0.01mm]
Lost Motion	0.05mm max [0.02mm max]
Guide	Base integrated type
Base	Material: Aluminum with white alumite treatment
X-axis motor output/lead	100W/20mm
Y-axis motor output/lead	60W/16mm
Z-axis motor output/lead	100W/16mm
Motor output of rotational axis	100W
Allowable inerted moment of rotational axis	0.015kg · m <sup>2</sup>
Allowable torque of rotational axis	1.9N · m

### Axis Configuration

\* Models of high-precision specification are shown in [ ].

Axis Name	Axis Name
X-axis	ISA [SPA]-MXM-□ - 100-20-(Stroke)
Y-axis	ISA [SPA]-SYM-□ - 60-16-(Stroke)
Z-axis/rotational-axis	ZR-S-□ - 100-16-150-T2-#-B-L

\* In the □ in the above model names, enter A (absolute) or I (incremental) as the applicable encoder type.  
# - Cable length

<p>Caution</p>	(Note 1) Strokes are expressed in cm (centimeters) in the model names.
	(Note 2) The cable length is measured from the X-axis connector box to the controller. Although the standard length is 3m or 5m, other lengths can also be specified in m (Meters). Cable lengths of up to 20 meters are supported.
	(Note 3) The actual value may be lower depending on the conditions of use.
	(Note 4) The rated acceleration is 0.3G. When the acceleration is increased, the loading capacity decreases.
	(Note 5) Take note that the maximum speed drops when the stroke becomes longer. If the robot is to be moved with the vertical axis lowered, raise the speed and acceleration.

# ICSA4 [ICSPA4] - BE□HZRS

## Loading Capacities (kg) (Note 4)

### BB□HZRS

		Y-axis Stroke			
		100	200	300	400
Z-axis Stroke	150	Rated: 1.0 kg (at acceleration/deceleration of 0.3 G) Maximum: 3.0 kg (at acceleration/deceleration of 0.1 G)			

## Maximum Speeds by Stroke (mm/s) (Note 5)

### BB□HZRS

	Stroke							
	100	200	300	400	500	600	700	800
X-axis	—	1000						795
Y-axis	800			—	—	—	—	—

Stroke : 150mm	
Z-axis	1005mm/s

  

Stroke: ±360°	
Rotational Axis	2200°/s

## Dimensions

\* The figure below is the figure for XY combination direction 1.

\* In the figure below, the cable track dimensions is CTM for the Y-axis and CT for the ZR-axes. (CT cannot be used for the Y-axis)

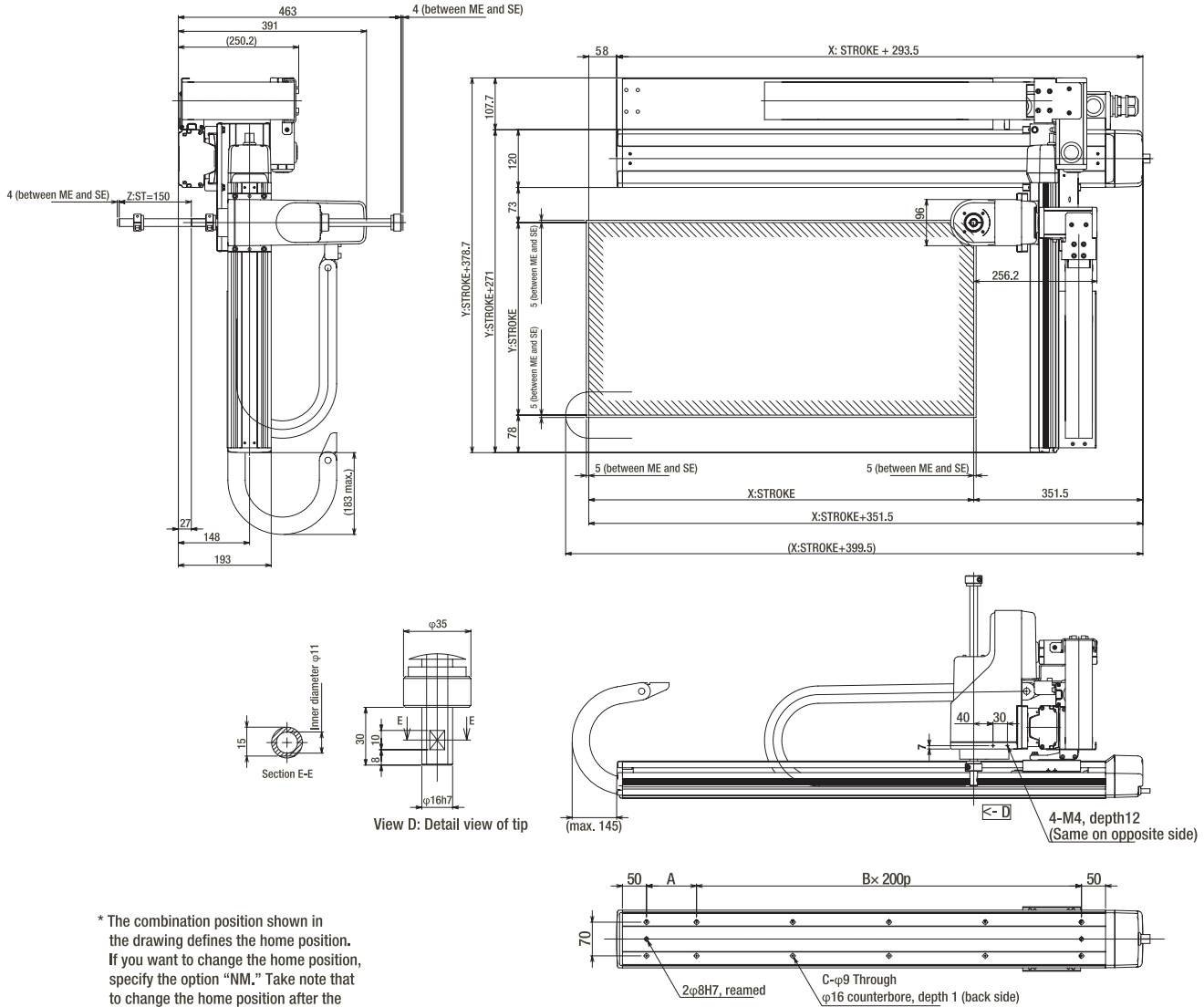

\* The combination position shown in the drawing defines the home position. If you want to change the home position, specify the option "NM." Take note that to change the home position after the delivery, the robot must be returned for adjustment.

X Stroke	200	300	400	500	600	700	800
A	104	204	104	204	104	204	104
B	1	1	2	2	3	3	4
C	6	6	8	8	10	10	12

### Brake Box (Accessory)

This device must be installed along the cable wired between the actuator and the actuator's encoder.

Brake Box Model: RCB-110-RA13-0

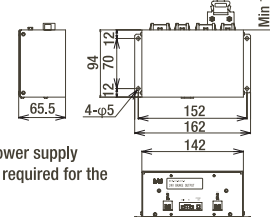

### Note

A 24-VDC power supply (1A max.) is required for the brake box.



# ICSA4-BE □ HZRM

Cartesian Robot 4-axis Combination of X/Y and ZR Unit

# ICSPA4-BE □ HZRM

Cartesian Robot 4-axis Combination of X/Y and ZR Unit

## High-precision Specification

### Model

Series	Type	Encoder	Stroke/options for axis 1	Stroke/options for axis 2	Stroke/options for axis 3	Operation range/Options for axis 4	Controller	Cable Length	Cable wiring for X-axis	Cable wiring for Z-axis
ICSA4: Standard 4-axis Specification ICSPA4: High-precision 4-axis Specification	Refer to model table below	A: Absolute I: Incremental	30:300mm 100:1000mm (100mm steps)	20:200mm 70:700mm (100mm steps)	20:200mm 70:700mm (100mm steps)	36:360 Deg Refer to options table below	T2:XSEL-P/Q	3L: 3m 5L: 5m □: Specified Length	Refer to Explanation of Symbols in Model Names below	Refer to Explanation of Symbols in Model Names below

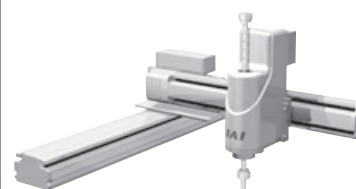

### Model

\* Models of high-precision specification are shown in [ ].

Encoder Model	XY combination direction (*1)	Z-axis Type	Model
Absolute	1	H	ICSA4 [ICSPA4]-BE1HZRM-A- <u>1</u> - <u>2</u> - <u>3</u> - <u>4</u> - <u>5</u> - <u>6</u> - <u>7</u> - <u>8</u>
	2	H	ICSA4 [ICSPA4]-BE2HZRM-A- <u>1</u> - <u>2</u> - <u>3</u> - <u>4</u> - <u>5</u> - <u>6</u> - <u>7</u> - <u>8</u>
	3	H	ICSA4 [ICSPA4]-BE3HZRM-A- <u>1</u> - <u>2</u> - <u>3</u> - <u>4</u> - <u>5</u> - <u>6</u> - <u>7</u> - <u>8</u>
	4	H	ICSA4 [ICSPA4]-BE4HZRM-A- <u>1</u> - <u>2</u> - <u>3</u> - <u>4</u> - <u>5</u> - <u>6</u> - <u>7</u> - <u>8</u>
Incremental	1	H	ICSA4 [ICSPA4]-BE1HZRM-I- <u>1</u> - <u>2</u> - <u>3</u> - <u>4</u> - <u>5</u> - <u>6</u> - <u>7</u> - <u>8</u>
	2	H	ICSA4 [ICSPA4]-BE2HZRM-I- <u>1</u> - <u>2</u> - <u>3</u> - <u>4</u> - <u>5</u> - <u>6</u> - <u>7</u> - <u>8</u>
	3	H	ICSA4 [ICSPA4]-BE3HZRM-I- <u>1</u> - <u>2</u> - <u>3</u> - <u>4</u> - <u>5</u> - <u>6</u> - <u>7</u> - <u>8</u>
	4	H	ICSA4 [ICSPA4]-BE4HZRM-I- <u>1</u> - <u>2</u> - <u>3</u> - <u>4</u> - <u>5</u> - <u>6</u> - <u>7</u> - <u>8</u>

\*1 See the figure below for the XY combination directions.

\* For the descriptions of [1] to [8] in the above model names, refer to the table provided in the top right.

\* The following adjustment jig (sold separately) is required for models of absolute specification:  
Absolute reset adjustment jig (model: JG-ZRM)

### Explanation of Symbols in Model Names

No.	Description	Indication
①	X-axis stroke (Note 1)	30 : 300mm 100 : 1000mm
②	Y-axis stroke (Note 1)	20 : 200mm 70 : 700mm
③	Z-axis stroke (Note 1)	20 : 200mm
④	R-axis Operation Range	36 : 360deg
⑤	Applicable Controllers	T2 : XSEL-P/Q
⑥	Cable Length (Note 2)	3L : 3m 5L : 5m
⑦	Y-axis Cable Wiring	CTM: Cable track size M (Standard) CTL: Cable track size L CTXL: Cable track size XL
⑧	Z-axis Cable Wiring	CT: Cable Track (Standard) CTM: Cable track size M CTL: Cable track size L CTXL: Cable track size XL

\*The above table describes [1] to [8] in the model names shown to the left.

### Options

Enter the applicable option symbol after the stroke of each axis. If multiple options are selected, enter them in alphabetical order.

Name	Model
AQ Seal	AQ
Brake	B
Creep Sensor	C
Home Limit Switch	L
Reversed Home Specification	NM
Guide with ball retention mechanism	RT

### XY Combination Directions

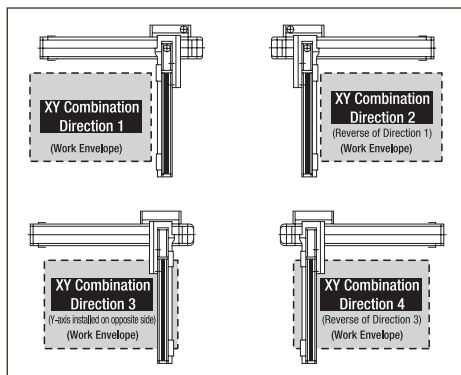

### Axis Configuration

\* Models of high-precision specification are shown in [ ].

Axis Name	Axis Name
X-axis	ISA [ISPA]-LXM-□-400-20-(Stroke)
Y-axis	ISA [ISPA]-MYM-□-200-20-(Stroke)
Z-axis/rotational-axis	ZR-M-□-200-20-200-T2-#-B-L

\* In the □ in the above model names, enter A (absolute) or I (incremental) as the applicable encoder type.  
# - Cable length

### Common Specifications

\* Models of high-precision specification are shown in [ ].

Drive Method	Ball screw, rolled C10 [rolled C5 or equivalent]
Positioning Repeatability	±0.02mm [±0.01mm]
Lost Motion	0.05mm max [0.02mm max]
Guide	Base integrated type
Base	Material: Aluminum with white alumite treatment
X-axis motor output/lead	400W/20mm
Y-axis motor output/lead	200W/20mm
Z-axis motor output/lead	200W/20mm
Motor output of rotational axis	200W
Allowable inertial moment of rotational axis	0.03kg · m <sup>2</sup>
Allowable torque of rotational axis	3.8N · m



Caution

(Note 1) Strokes are expressed in cm (centimeters) in the model names.  
(Note 2) The cable length is measured from the X-axis connector box to the controller. Although the standard length is 3m or 5m, other lengths can also be specified in m (Meters). Cable lengths of up to 20 meters are supported.  
(Note 3) The actual value may be lower depending on the conditions of use.  
(Note 4) The rated acceleration is 0.3G. When the acceleration is increased, the loading capacity decreases.  
(Note 5) Take note that the maximum speed drops when the stroke becomes longer. If the robot is to be moved with the vertical axis lowered, raise the speed and acceleration.



# ICSA4 [ICSPA4] - BE □ HZRM

## Loading Capacities (kg) (Note 4)

### BB □ HZRM

		Y-axis Stroke					
		200	300	400	500	600	700
Z-axis Stroke	200	Rated: 2.0 kg (at acceleration/deceleration of 0.3 G) Maximum: 6.0 kg (at acceleration/deceleration of 0.1 G)					

## Maximum Speeds by Stroke (mm/s) (Note 5)

### BB □ HZRM

	Stroke									
	100	200	300	400	500	600	700	800	900	1000
X-axis	—	—	—	—	1000	—	—	—	830	690
Y-axis	—	—	—	1000	—	—	—	—	—	—

Stroke : 200mm	
Z-axis	1256mm/s
Stroke : ±360°	
Rotational Axis	2200°/s

## Dimensions

\* The figure below is the figure for XY combination direction 1.

\* In the figure below, the cable track dimensions is CTM for the Y-axis and CT for the ZR-axes. (CT cannot be used for the Y-axis)

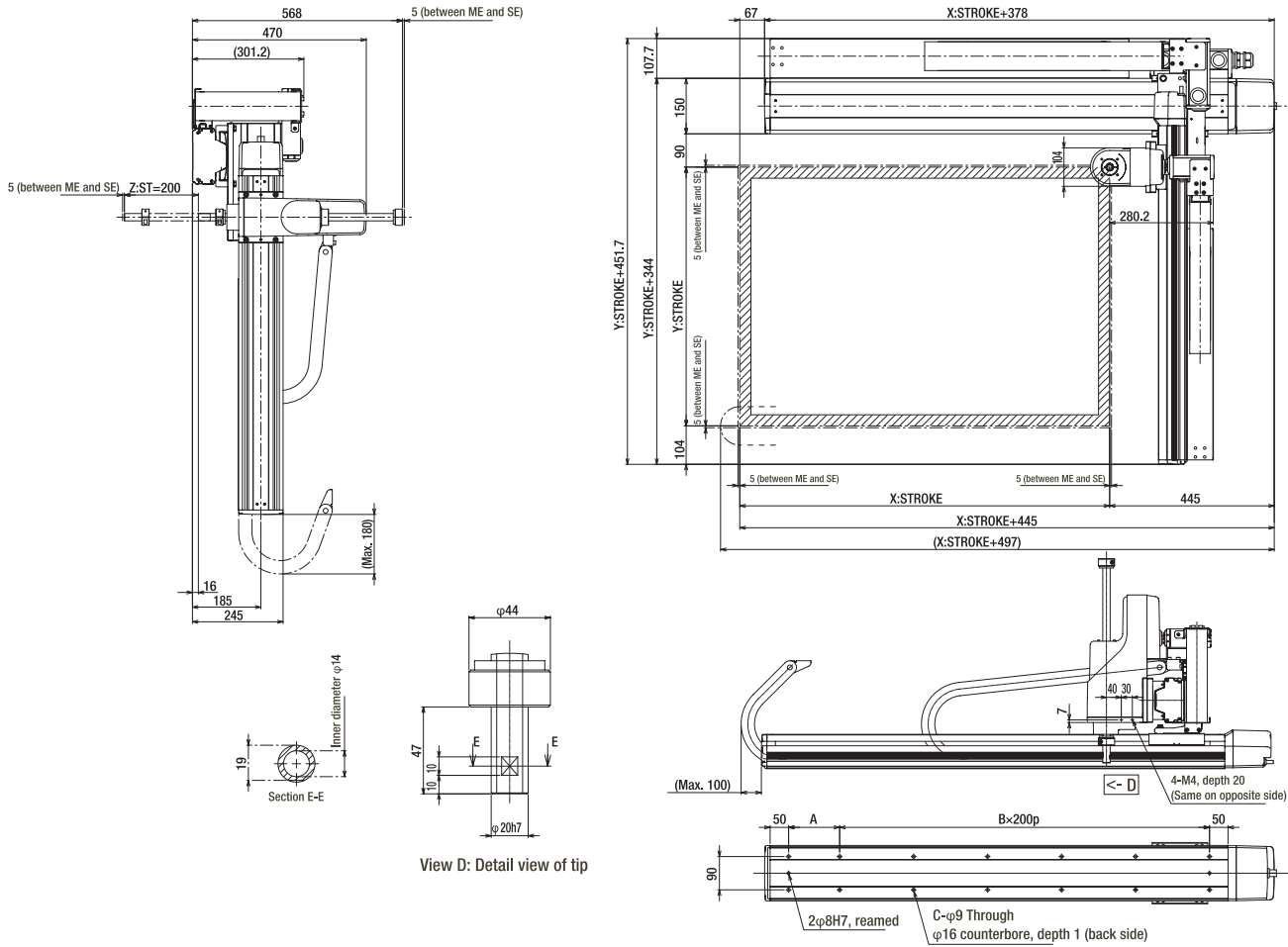

\* The combination position shown in the drawing defines the home position. If you want to change the home position, specify the option "NM." Take note that to change the home position after the delivery, the robot must be returned for adjustment.

## Brake Box (Accessory)

This device must be installed along the cable wired between the actuator and the actuator's encoder.  
Brake Box Model: RCB-110-RA13-0

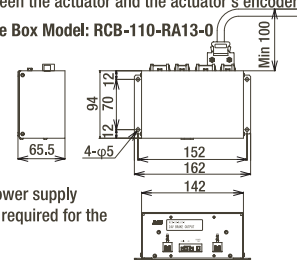

## Note

A 24-VDC power supply (1A max.) is required for the brake box.

X Stroke	300	400	500	600	700	800	900	1000
A	238	138	238	138	238	138	238	138
B	1	2	2	3	3	4	4	5
C	6	8	8	10	10	12	12	14



# OVER 30 YEARS OF IAI!

**E**STABLISHED IN 1976, IAI HAS GROWN GLOBALLY TO SERVE OVER 12 COUNTRIES. IAI HAS 24 REGIONAL OFFICES IN JAPAN AND IS PROUD TO ANNOUNCE A NEWLY CONSTRUCTED HEADQUARTERS, WITH AN ADJACENT STATE OF THE ART MANUFACTURING FACILITY TO PRODUCE THE HIGHEST QUALITY AUTOMATION ROBOTS. IAI IS CONSTANTLY STRIVING IN THE PURSUIT OF 'QUALITY AND INNOVATION.' OUR FOCUS IS ALWAYS ON THE CUSTOMERS AND THEIR NEEDS; AND TO OFFER HIGH QUALITY AND INNOVATIVE SOLUTIONS TAILORED FOR SPECIFIC CUSTOMER APPLICATIONS. IAI AMERICA INC. WAS ESTABLISHED IN 1989 TO BETTER SERVE THE NEEDS OF FACTORY AUTOMATION. WITH 3 MAIN OFFICES IN THE UNITED STATES, SUPPORT IS ALWAYS A PHONE CALL AWAY WHERE YOU CAN REACH EXPERIENCED ENGINEERS.

FROM OUR EASY TO USE SOFTWARE, TO COMPLETE AUTOMATION SOLUTIONS, WE PROVIDE YOU WITH THE TOOLS NECESSARY TO SCALE YOUR BUSINESS. WHEN YOU DEMAND INNOVATIVE AND HIGH QUALITY ROBOTS, EXCELLENT SERVICE AND SUPPORT FOR YOUR UNIQUE NEEDS, DEMAND IAI!



#### IAI Headquarters

On the windows of the newly constructed headquarters spell out the character for 'heart' in Japanese. This character is rich and meaningful, symbolizing the heart, spirit, attention and sincerity of IAI's commitment to the users of IAI products.

#### ISO 9001:2000

IAI has been certified for ISO 9001:2000 and JIS Q9001:2000 by an independent auditor to be in conformance with ISO 9001:2000 and JIS 9001:2000. We at IAI are continually improving our methods to produce quality products and services that surpass customer expectations.



#### RoHS Compliant

IAI is RoHS compliant and recognizes the responsibility in reducing hazardous substances to better serve our customers and our environment.

